



## Technology Focus: Data Acquisition

### ➤ Scheme for Entering Binary Data Into a Quantum Computer

This could be an important step toward making quantum computing practical.

NASA's Jet Propulsion Laboratory, Pasadena, California

A quantum algorithm provides for the encoding of an exponentially large number of classical data bits by use of a smaller (polynomially large) number of quantum bits (qubits). The development of this algorithm was prompted by the need, heretofore not satisfied, for a means of entering real-world binary data into a quantum computer. The data format provided by this algorithm is suitable for subsequent ultrafast quantum processing of the entered data. Potential applications lie in disciplines (e.g., genomics) in which one needs to search for matches between parts of very long sequences of data. For example, the algorithm could be used to encode the  $N$ -bit-long human genome in only  $\log_2 N$  qubits. The resulting  $\log_2 N$ -qubit state could then be used for subsequent quantum data processing — for example, to perform rapid comparisons of sequences.

Below are the steps of the algorithm, illustrated with the example of the four-bit string 0111:

1. Specify a correspondence between (a) each classical bit in a string of  $2^n$  such bits and (b) a unique  $n$ -bit eigenstate in a set of  $2^n$  such eigenstates. For example, if a classical  $2^2$ -bit string

is 0111, then the corresponding four 2-bit eigenstates could be  $|00\rangle$ ,  $|01\rangle$ ,  $|10\rangle$ , and  $|11\rangle$ .

2. Construct a superposition,  $|\psi\rangle$ , of equally weighted quantum states that is peaked at only those eigenstates that correspond to 1s in the classical bit string. In the example of the bit string 0111, the corresponding 2-qubit state would be  $|\psi\rangle = 3^{-1/2}(|01\rangle+|10\rangle+|11\rangle)$ . In the general case, the superposition would be an entangled state of  $n$  qubits that encodes a specific sequence of  $2^n$  classical bits.
3. Compute the unitary transformation needed to obtain the superposition starting from an easy-to-make state (for example,  $|00\rangle$ ). Equivalently, compute a unitary matrix that maps the chosen state (e.g.,  $|00\rangle$ ) into the state  $|\psi\rangle$ . For the classical bit string 0111, the unitary matrix would be

$$\begin{pmatrix} 0 & -1/\sqrt{3} & -1/\sqrt{3} & -1/\sqrt{3} \\ 1/\sqrt{3} & 2/3 & -1/3 & -1/3 \\ 1/\sqrt{3} & -1/3 & 2/3 & -1/3 \\ 1/\sqrt{3} & -1/3 & -1/3 & 2/3 \end{pmatrix}$$

To compute the matrix, first compute  $|\psi\rangle\langle\psi|$  (which gives one column of the

matrix), then generate the remaining orthonormal vectors for the other columns.

4. By use of software developed previously for this purpose, compute the form of a feasible quantum circuit equivalent to the unitary matrix. The quantum circuit could be implemented in one of several physical embodiments: for example, spin-based, charge-based, optical, or superconducting quantum computer hardware.

*This work was done by Colin Williams of Caltech for NASA's Jet Propulsion Laboratory. Further information is contained in a TSP (see page 1).*

*In accordance with Public Law 96-517, the contractor has elected to retain title to this invention. Inquiries concerning rights for its commercial use should be addressed to:*

*Innovative Technology Assets Management  
JPL*

*Mail Stop 202-233  
4800 Oak Grove Drive  
Pasadena, CA 91109-8099  
(818) 354-2240*

*E-mail: [iaoffice@jpl.nasa.gov](mailto:iaoffice@jpl.nasa.gov)*

*Refer to NPO-30209, volume and number of this NASA Tech Briefs issue, and the page number.*

### ➤ Encryption for Remote Control via Internet or Intranet

This protocol provides security against control by unauthorized users.

John F. Kennedy Space Center, Florida

A data-communication protocol has been devised to enable secure, reliable remote control of processes and equipment via a collision-based network, while using minimal bandwidth and computation. The network could be the Internet or an intranet. Control is made secure by use of both a password and a dynamic key, which is sent transparently to a remote user by the controlled computer (that is, the computer, located at the site of the equipment or process to be controlled,

that exerts direct control over the process). The protocol functions in the presence of network latency, overcomes errors caused by missed dynamic keys, and defeats attempts by unauthorized remote users to gain control. The protocol is not suitable for real-time control, but is well suited for applications in which control latencies up to about 0.5 second are acceptable.

The encryption scheme involves the use of both a dynamic and a private key, without any additional overhead

that would degrade performance. The dynamic key is embedded in the equipment- or process-monitor data packets sent out by the controlled computer: in other words, the dynamic key is a subset of the data in each such data packet. The controlled computer maintains a history of the last 3 to 5 data packets for use in decrypting incoming control commands. In addition, the controlled computer records a private key (password) that is given to the remote computer. The encrypted

incoming command is permuted by both the dynamic and private key. A person who records the command data in a given packet for hostile purposes cannot use that packet after the public key expires (typically within 3 seconds). Even a person in possession of an unauthorized copy of the command/remote-display software cannot use that software in the absence of the password.

The use of a dynamic key embedded in the outgoing data makes the central-processing unit overhead very small. The use of a National Instruments DataSocket™ (or equivalent) protocol or the User Datagram Protocol makes it possible to obtain reasonably short response times: Typical response times in event-driven control, using packets sized  $\leq 300$  bytes, are  $< 0.2$  second for

commands issued from locations anywhere on Earth.

The protocol requires that control commands represent absolute values of controlled parameters (e.g., a specified temperature), as distinguished from changes in values of controlled parameters (e.g., a specified increment of temperature). Each command is issued three or more times to ensure delivery in crowded networks. The use of absolute-value commands prevents additional (redundant) commands from causing trouble. Because a remote controlling computer receives “talkback” in the form of data packets from the controlled computer, typically within a time interval  $\leq 1$  s, the controlling computer can re-issue a command if network failure has occurred.

The controlled computer, the process

or equipment that it controls, and any human operator(s) at the site of the controlled equipment or process should be equipped with safety measures to prevent damage to equipment or injury to humans. These features could be a combination of software, external hardware, and intervention by the human operator(s). The protocol is not fail-safe, but by adopting these safety measures as part of the protocol, one makes the protocol a robust means of controlling remote processes and equipment by use of typical office computers via intranets and/or the Internet.

*This work was done by Lewis Lineberger of Kennedy Space Center. For further information, contact the Kennedy Commercial Technology Office at (321) 867-8130. KSC-12277*

## Coupled Receiver/Decoders for Low-Rate Turbo Codes

Residual carrier power needed for recovery of phase would be reduced.

NASA's Jet Propulsion Laboratory, Pasadena, California

Coupled receiver/decoders have been proposed for receiving weak single-channel phase-modulated radio signals bearing low-rate-turbo-coded binary data. Originally intended for use in receiving telemetry signals from distant spacecraft, the proposed receiver/decoders may also provide enhanced reception in mobile radiotelephone systems.

A radio signal of the type to which the proposal applies comprises a residual carrier signal and a phase-modulated data signal. The residual carrier signal is needed as a phase reference for demodulation as a prerequisite to decoding. Low-rate turbo codes afford high coding gains and thereby enable the extraction of data from arriving radio signals that might otherwise be too weak. In the case of a conventional receiver, if the signal-to-noise ratio (specifically, the symbol energy to one-sided noise power spectral density) of the arriving signal is below approximately 0 dB, then there may not be enough energy per symbol to enable the receiver to recover properly the carrier phase. One could solve the problem at the transmitter by diverting some power from the data signal to the residual carrier. A better solution — a coupled receiver/decoder according to the proposal — could re-

duce the needed amount of residual carrier power.

In all that follows, it is to be understood that all processing would be digital and the incoming signals to be

processed would be, more precisely, outputs of analog-to-digital converters that preprocess the residual carrier and data signals at a rate of multiple samples per symbol. The upper part of the

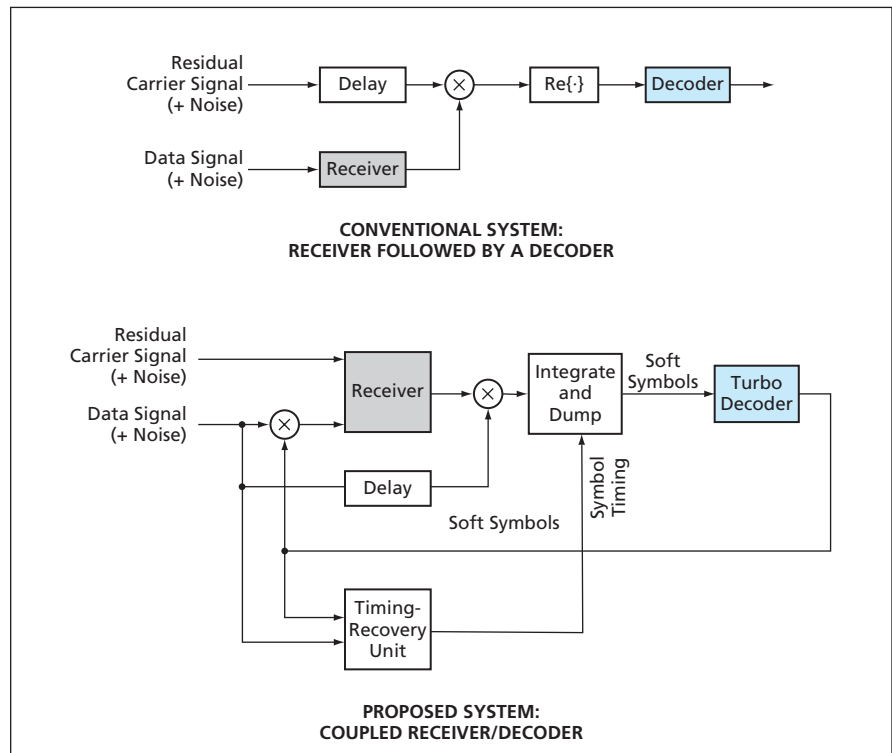

A Coupled Receiver/Decoder would utilize data feedback from its turbo decoder, whereas a conventional receiver does not utilize data from the turbo decoder that follows it.