

Like other laser Doppler velocimeters, this instrument includes optics that split a laser beam into two parts that impinge on the probe volume from two different directions to form interference fringes in the probe volume. Also like other laser Doppler velocimeters, this instrument measures the frequency of variation of light reflected by particles entrained in the flow as they pass through the fringes (the velocity component that one seeks to measure is simply the product of this frequency and the fringe spacing). What distinguishes this instrument from other laser Doppler velocimeters is its highly miniaturized design and its unique fringe geometry.

The instrument (see figure) includes a diode laser, the output of which is shaped by a diffractive optical element (DOE) into two beams that have elliptical cross sections with very high aspect ratios. The DOE focuses these beams through two slits a few microns apart on a surface that, in use, is mounted flush with the wall that bounds the flow. Light reflected from flow particles that pass through the fringes is collected through a window (essentially, a third, wider slit). Another DOE acts as focusing lens that couples the collected light into an opti-

cal fiber that, in turn, couples the light to an avalanche photodiode. The output of the photodiode is processed to measure the frequency of variation in the intensity of the reflected light.

The interference between the laser beams forms fringes that diverge by an amount proportional to the distance from the wall: the fringes appear as radial spokes in the plane that contains a parallel-to-the-wall velocity component to be measured. Because the magnitude of this velocity component also increases linearly with distance from the wall in the viscosity-dominated flow regime and because the corresponding component of shear stress is proportional to the perpendicular-to-the-wall gradient of this velocity component, it follows that the frequency of variation of light reflected by particles entrained in the flow is proportional to the shear-stress component that one seeks to measure.

The critical optical components for manipulating the laser light are fabricated on a 0.5-mm-thick quartz substrate in a sequence of microfabrication steps. The front surface (the top surface in the figure) is coated with a thin film of chromium, then further coated with poly(methyl methacrylate) [PMMA].

The slits and window are formed in the chromium film by electron-beam lithography followed by wet etching. The back surface is coated with PMMA, in which the DOEs are formed by electron-beam lithography. The unitary assembly of optical components thus formed is mounted in a compact housing that also holds the diode laser and the fiber-optic-coupled photodiode.

This work was done by Morteza Gharib, Darius Modarress, Siamak Forouhar, Dominique Fourguette, Federic Taugwalder, and Daniel Wilson of Caltech for NASA's Jet Propulsion Laboratory. Further information is contained in a TSP (see page 1).

In accordance with Public Law 96-517, the contractor has elected to retain title to this invention. Inquiries concerning rights for its commercial use should be addressed to:

*Innovative Technology Assets Management
JPL*

*Mail Stop 202-233
4800 Oak Grove Drive
Pasadena, CA 91109-8099
(818) 354-2240*

E-mail: iaoffice@jpl.nasa.gov

Refer to NPO-20851, volume and number of this NASA Tech Briefs issue, and the page number.

Coherent Laser Instrument Would Measure Range and Velocity

This lightweight, low-power, compact instrument could have a variety of uses.

NASA's Jet Propulsion Laboratory, Pasadena, California

A proposed instrument would project a narrow laser beam that would be frequency-modulated with a pseudo-random noise (PN) code for simultaneous measurement of range and velocity along the beam. The instrument performs these functions in a low mass, power, and volume package using a novel combination of established techniques. Originally intended as a low resource-footprint guidance sensor for descent and landing of small spacecraft onto Mars or small bodies (e.g., asteroids), the basic instrument concept also lends itself well to a similar application guiding aircraft (especially, small unmanned aircraft), and to such other applications as ranging of topographical features and measuring velocities of airborne light-scattering particles as wind indicators.

Several key features of the instrument's design contribute to its favor-

able performance and resource-consumption characteristics. A laser beam is intrinsically much narrower (for the same exit aperture telescope or antenna) than a radar beam, eliminating the need to correct for the effect of sloping terrain over the beam width, as is the case with radar. Furthermore, the use of continuous-wave (CW), erbium-doped fiber lasers with excellent spectral purity (narrow line width) permits greater velocity resolution, while reducing the laser's power requirement compared to a more typical pulsed solid-state laser. The use of CW also takes proper advantage of the increased sensitivity of coherent detection, necessary in the first place for direct measurement of velocity using the Doppler effect. However, measuring range with a CW beam requires modulation to "tag" portions of it for time-of-flight determination; typically, the

modulation consists of a PN code. A novel element of the instrument's design is the use of frequency modulation (FM) to accomplish both the PN-modulation and the Doppler-bias frequency shift necessary for signed velocity measurements. This permits the use of a single low-power waveguide electro-optic phase modulator, while simultaneously mitigating the effects of speckle as a noise source in the coherent detection.

The instrument (see figure) would include a narrow-line-width CW laser, the output of which would be split into a local oscillator and signal arm. Within the instrument, optical beams would be routed, split, and combined by use of fiber and planar integrated optics. The signal arm beam would be frequency-modulated by the electro-optic phase modulator, fed by a serrodyne waveform generated either in software or hard-

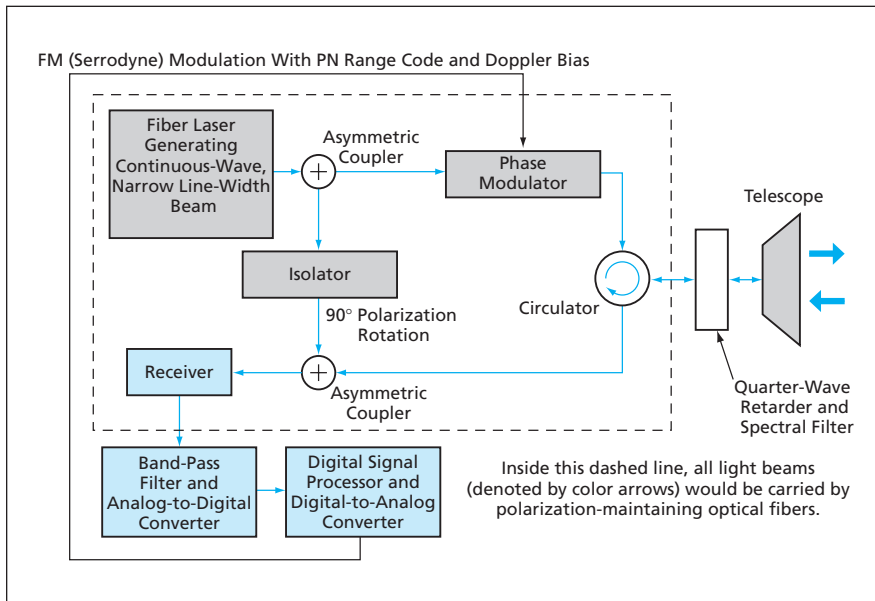

The **Proposed Laser Instrument** would perform ranging and velocimetry by use of a novel combination of established techniques. Integrated and fiber optics would be used to implement much of the functionality in a compact, lightweight package.

ware, then sent through a multiplexer to a fixed-focus collimating telescope. The combination of a fiber-coupled Faraday circulator and a quarter-wave polarization retarder forms an effective transmit/receive multiplexer, as well as outputting the desired circular polarization.

The return signal, coupled back into the instrument by the same telescope, would be mixed with the local oscillator beam in a semiconductor optical receiver. The resulting heterodyne signal would be filtered, then directly digitized for processing in the digital signal processor, where frequency demodulation and PN-code correlation would be performed, with phase-edge detection and tracking for increased range accuracy.

This work was done by Daniel Chang, Greg Cardell, Alejandro San Martin, and Gary Spiers of Caltech for NASA's Jet Propulsion Laboratory. Further information is contained in a TSP (see page 1). NPO-40403