

ink that contains the ingredients described for step 2, plus 0.035 g of poly(tetrafluoroethylene) particles.

5. The membrane coated with catalyst layer is bonded to the gas-diffusion/current-collecting carbon paper by use of heat and pressure.

The performance of membrane electrode assemblies prepared by the new process is compared with those prepared by the state-of-art (SOA) process in Figure 2. The current density at 0.49 V has been raised from 70 mA/cm<sup>2</sup> to 100 mA/cm<sup>2</sup>. This results in an increase in

power density of 43 percent. At an applied current density of 100 mA/cm<sup>2</sup>, the cell voltage for the SOA cell and improved cell are 0.43 and 0.49, respectively. The increase in cell voltage between the SOA and improved cell resulted in an increase in cell efficiency of 8 percent when the effects of crossover are included.

*This work was done by Thomas Valdez and Sekharipuram Narayanan of Caltech for NASA's Jet Propulsion Laboratory. Further information is contained in a TSP (see page 1).*

*In accordance with Public Law 96-517, the contractor has elected to retain title to this invention. Inquiries concerning rights for its commercial use should be addressed to:*

*Innovative Technology Assets Management  
JPL*

*Mail Stop 202-233  
4800 Oak Grove Drive  
Pasadena, CA 91109-8099  
(818) 354-2240*

*E-mail: [iaoffice@jpl.nasa.gov](mailto:iaoffice@jpl.nasa.gov)*

*Refer to NPO-30829, volume and number of this NASA Tech Briefs issue, and the page number.*

## X-Band, 17-Watt Solid-State Power Amplifier

**This is a smaller, lighter, less expensive alternative to prior X-band amplifiers.**

*NASA's Jet Propulsion Laboratory, Pasadena, California*

An advanced solid-state power amplifier that can generate an output power of as much as 17 W at a design operating frequency of 8.4 GHz has been designed and constructed as a smaller, lighter, less expensive alternative to traveling-

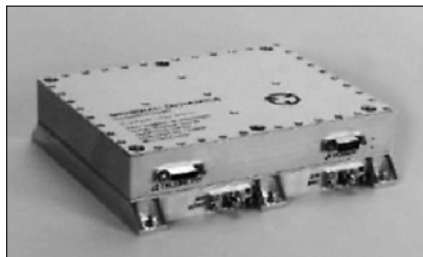

Figure 1. The Complete Amplifier Package has dimensions of 6.75 by 5.25 by 1.75 in. (about 17.1 by 13.3 by 4.4 cm).

wave-tube X-band amplifiers and to prior solid-state X-band power amplifiers of equivalent output power. This amplifier comprises a monolithic microwave integrated circuit (MMIC) amplifier module and a power-converter module integrated into a compact package (see Figure 1).

The amplifier module contains an input variable-gain amplifier (VGA), an intermediate driver stage, a final power stage, and input and output power monitors (see Figure 2). The VGA and the driver amplifier are 0.5- $\mu$ m GaAs-based metal semiconductor field-effect transistors (MESFETs). The final power stage contains four parallel high-efficiency, GaAs-based pseudomorphic high-electron-mobility transistors (PHEMTs). The

gain of the VGA is voltage-variable over a range of 10 to 24 dB. To provide for temperature compensation of the overall amplifier gain, the gain-control voltage is generated by an operational-amplifier circuit that includes a resistor/thermistor temperature-sensing network. The driver amplifier provides a gain of 14 dB to an output power of 27 dBm to drive the four parallel output PHEMTs, each of which is nominally capable of putting out as much as 5 W. The driver output is sent to the input terminals of the four parallel PHEMTs through microstrip power dividers; the outputs of these PHEMTs are combined by microstrip power combiners (which are similar to the microstrip power dividers) to obtain the final output power of 17 W.

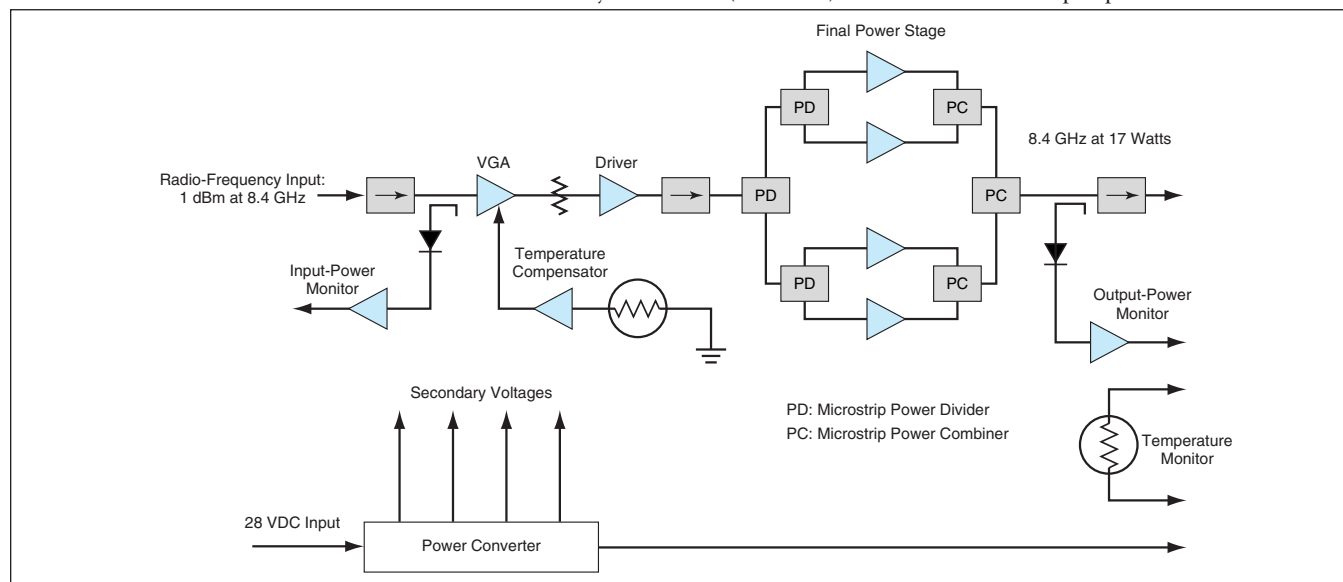

Figure 2. This Block Diagram shows only major functional blocks of the amplifier and power-converter modules.

The power-converter module contains a high-efficiency (nominally 90-percent efficient) DC-to-DC power converter plus analog signal-conditioning circuitry for use in remote monitoring (e.g., telemetry) of temperature, and of radio-frequency input and output power levels. The power converter contains a transformer in a push-pull, pulse-width-modulated buck regulator circuit. Feedback for regulation of power-converter output voltages is provided by a transformer winding that is in addition to the primary and secondary winding. Feedback-loop compen-

sation is provided by an error amplifier and associated resistors and capacitors within the pulse-width modulator. To maximize efficiency, the output voltages are obtained via synchronous rectifiers connected to the secondary winding of the transformer. The ripple in the outputs of the rectifiers is attenuated by use of inductance-capacitance filters.

The output power of 17 W is obtained with a nominal input radio-frequency power of 1 dBm ( $\approx 1.3$  mW) and an input DC power of 59 W. The amplifier and power-converter modules are configured

and stacked in a manner that provides the best thermally conductive path for dissipating heat generated in the final power stage. The amplifier can operate over a temperature range from  $-40$  to  $+70$  °C, from sea-level to Mars' atmosphere and even to a vacuum.

*This work was done by Anthony Mittskus and Ernest Stone of Caltech and William Boger, David Burgess, Richard Honda, and Carl Nuckolls of General Dynamics Decision Systems for NASA's Jet Propulsion Laboratory. Further information is contained in a TSP (see page 1). NPO-30663*

## Improved Anode for a Direct Methanol Fuel Cell

Electrical resistance is decreased and utilization of catalyst is increased.

NASA's Jet Propulsion Laboratory, Pasadena, California

A modified chemical composition has been devised to improve the performance of the anode of a direct methanol fuel cell. The main feature of the modified composition is the incorporation of hydrous ruthenium oxide into the anode structure. This modification can reduce the internal electrical resistance of the cell and increase the degree of utilization of the anode catalyst. As a result, a higher anode current density can be sustained with a smaller amount of anode catalyst. These improvements can translate into a smaller fuel-cell system and higher efficiency of conversion.

Some background information is helpful for understanding the benefit afforded by the addition of hydrous ruthenium oxide. The anode of a direct methanol fuel cell sustains the electro-oxidation of methanol to carbon dioxide in the reaction  $\text{CH}_3\text{OH} + \text{H}_2\text{O} \rightarrow \text{CO}_2 + 6\text{H}^+ + 6\text{e}^-$ . An electrocatalyst is needed to enable this reaction to occur. The catalyst that offers the highest activity is an alloy of approximately equal numbers of atoms of the noble metals platinum and ruthenium. The anode is made of a composite material that includes high-surface-area Pt/Ru-alloy particles and a proton-conducting ionomeric material. This composite is usu-

ally deposited onto a polymer-electrolyte (proton-conducting) membrane and onto an anode gas-diffusion/current-collector sheet that is subsequently bonded to the proton-conducting membrane by hot pressing.

Heretofore, the areal density of noble-metal catalyst typically needed for high performance has been about  $8 \text{ mg/cm}^2$ . However, not all of the catalyst has been utilized in the catalyzed electro-oxidation reaction. Increasing the degree of utilization of the catalyst would make it possible to improve the performance of the cell for a given catalyst loading and/or reduce the catalyst loading (thereby reducing the cost of the cell).

The use of carbon and possibly other electronic conductors in the catalyst layer has been proposed for increasing the utilization of the catalyst by increasing electrical connectivity between catalyst particles. However, the relatively low density of carbon results in thick catalyst layers that impede the mass transport of methanol to the catalytic sites. Also, the electrical conductivity of carbon is less than  $1/300$ th of typical metals. Furthermore, the polymer-electrolyte membrane material is acidic and most metals are not chemically stable in contact with it. Finally, a material that conducts electrons (but not protons) does not contribute to the needed transport of protons produced in the electro-oxidation reaction.

Hence, what is needed is an additive that is stable in contact with the polymer-electrolyte membrane and that conducts both electrons and protons. Hydrous

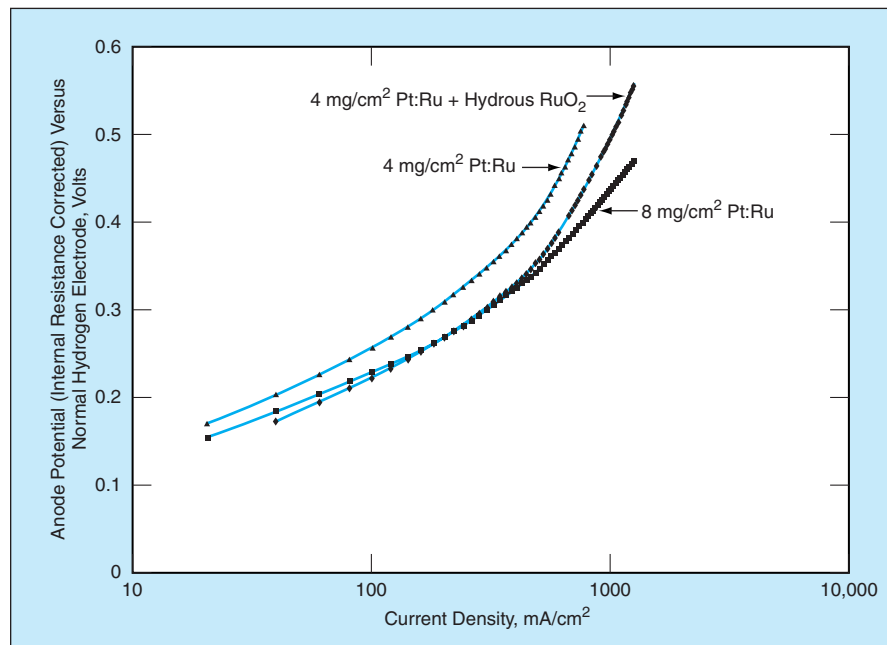

These Plots of Anode Overpotential Versus Current Density were obtained in tests of direct methanol fuel cells operated at a temperature of 90 °C and a methanol concentration of 1 M.