

Airframe Noise Reduction Status and Plans

Mehdi R. Khorrami
AT Noise Reduction Element Lead
Environmentally Responsible Aviation
Integrated Systems Research Program

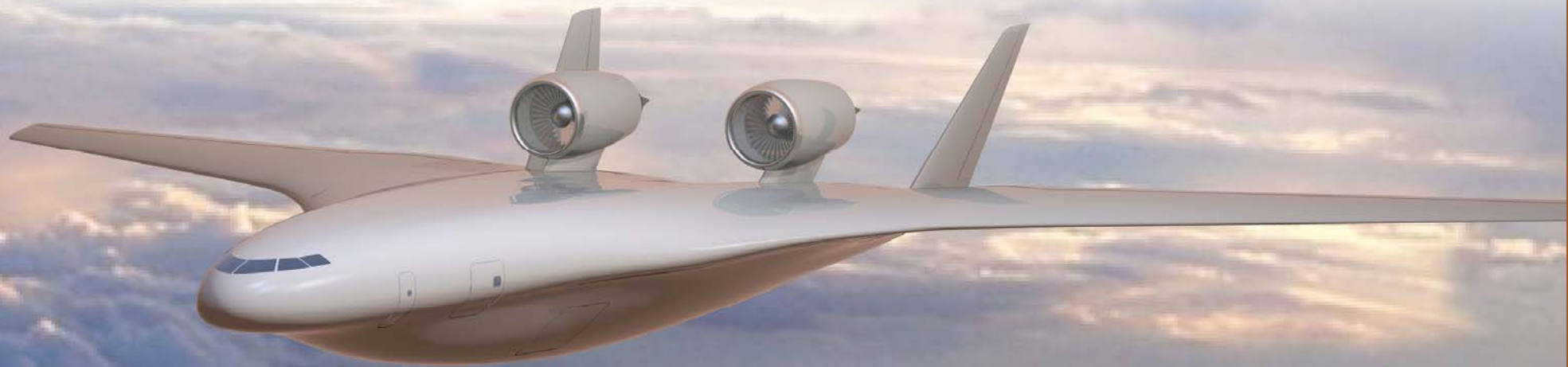

AIAA Aero Sciences Meeting
January 4-7, 2011

Airframe Noise



- Non-propulsive
- Most important during approach
- Broadband and noncompact
- Under-carriage and high-lift devices are prominent airframe noise sources
- Potentially large payoff from reducing airframe noise





Objectives

- Mitigate radiated airframe noise during aircraft landing
- Develop effective noise reduction (NR) concepts applicable to current and future generations of civil transport

Execution Plan

- Utilize flight tests, wind-tunnel experiments, and computational simulations to generate a comprehensive aerodynamic and acoustic database to:
 - » Identify and quantify the prominent airframe noise sources
 - » Better understand the principles of airframe noise generation
 - » Improve airframe noise prediction tools
 - » Establish Reynolds number, geometric fidelity, and installation effects
 - » Develop efficient noise reduction concepts
- Evaluate the most promising noise reduction concepts in a realistic environment

NASA-Gulfstream Airframe Noise Flight Test (2006)



Main Gear and Flaps only

Flaps only

Main Gear only

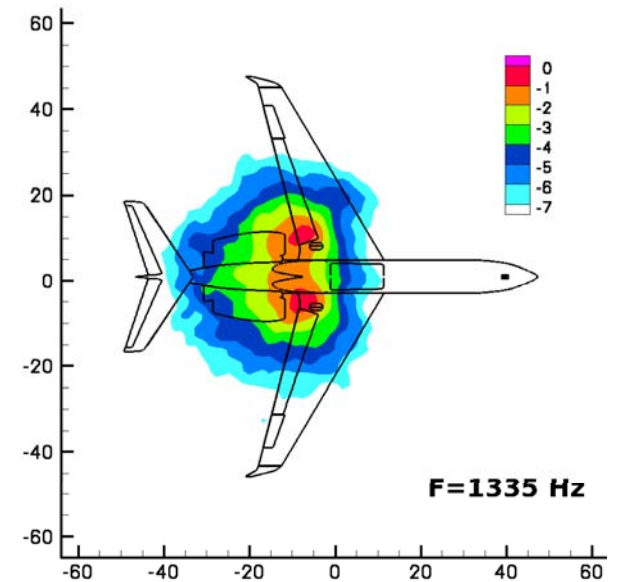
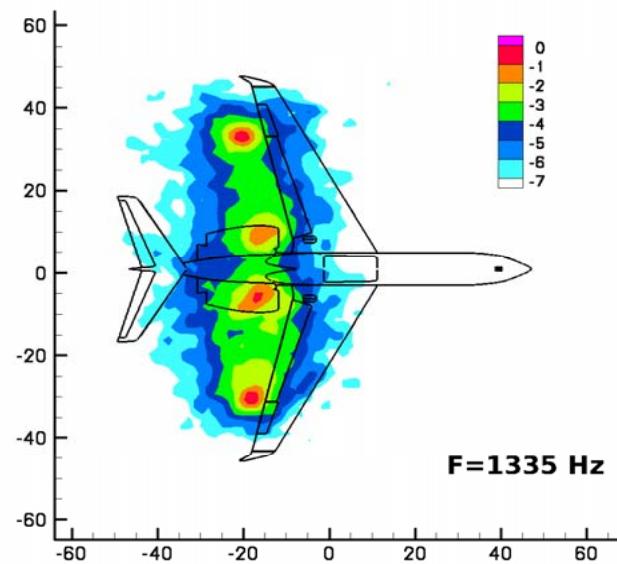
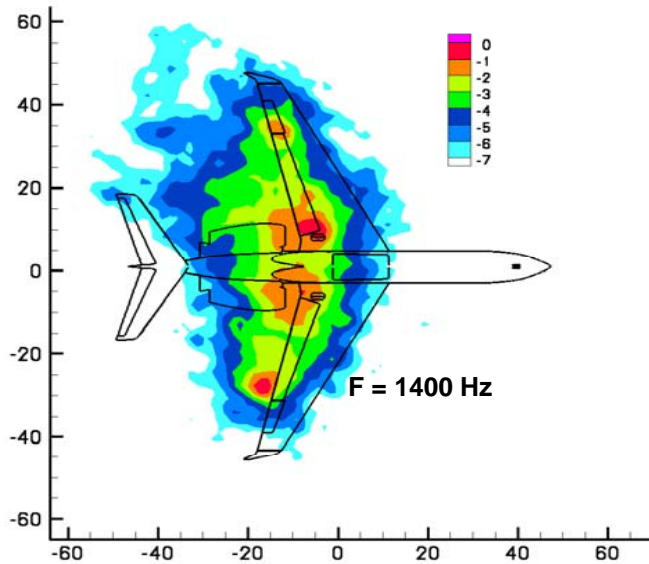

Nose Landing Gear



Acoustic Flight Test (2006)



Nose Gear only

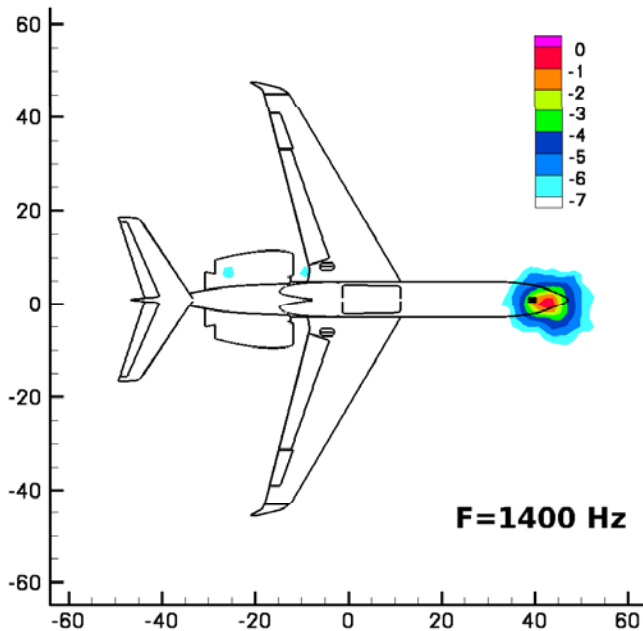

25% Scale Model tests (2007-2010)

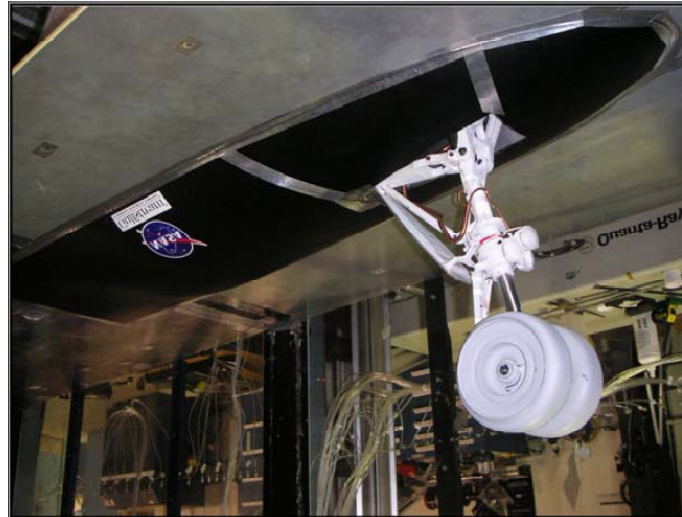

Acoustic measurements
University of Florida

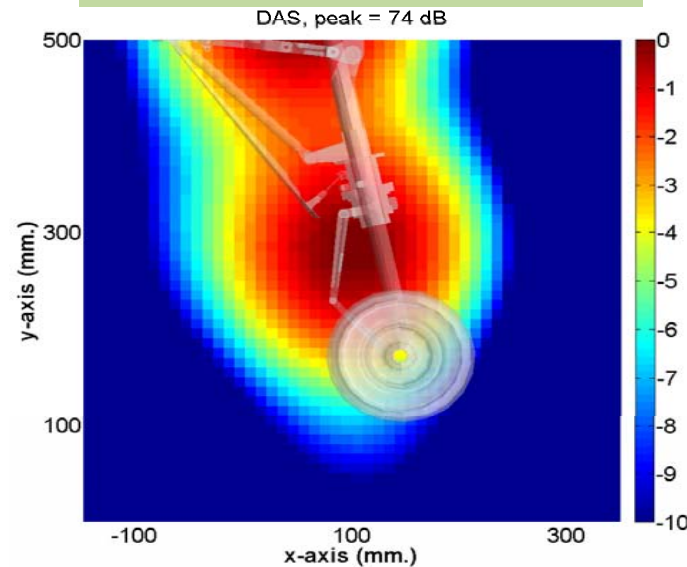

Unsteady Simulations (ongoing)

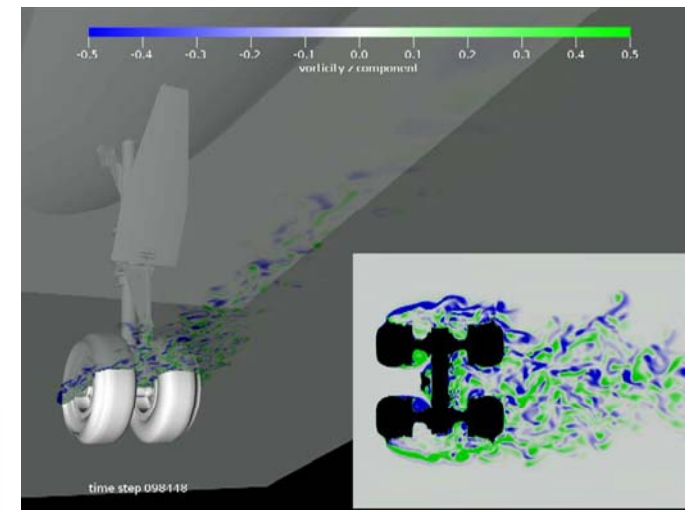
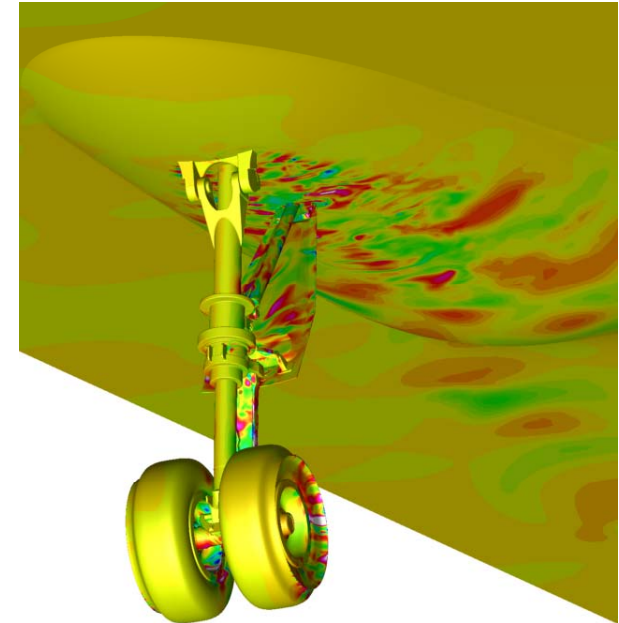

Semi-Span G550 Model

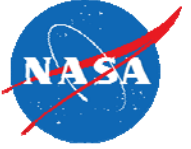

- High fidelity model
 - 18% of full-scale
 - Geometric details captured
 - Fully metric
- Heavily instrumented
 - 750 steady pressure ports
 - 68 unsteady pressure sensors
 - 14 accelerometers
- Model delivered on 9-24-10

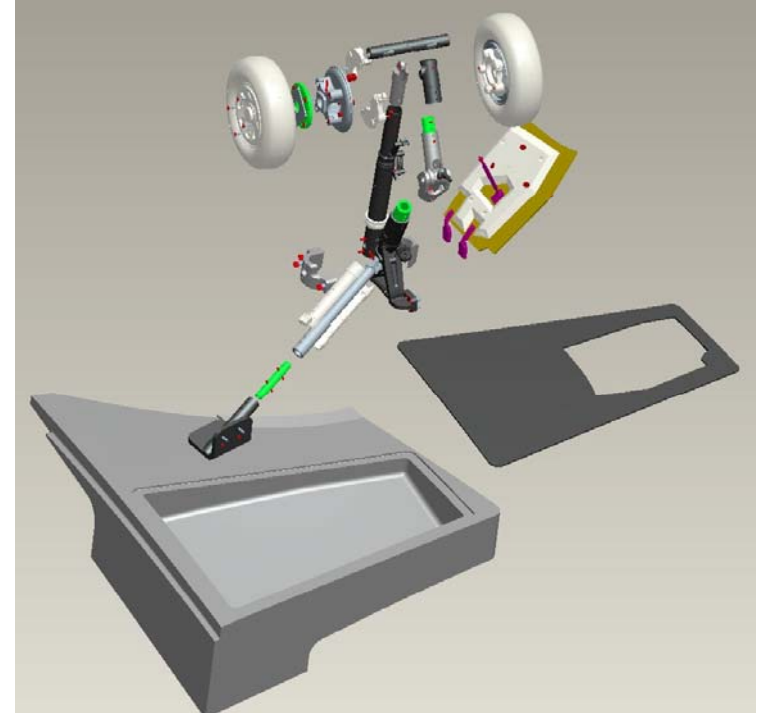
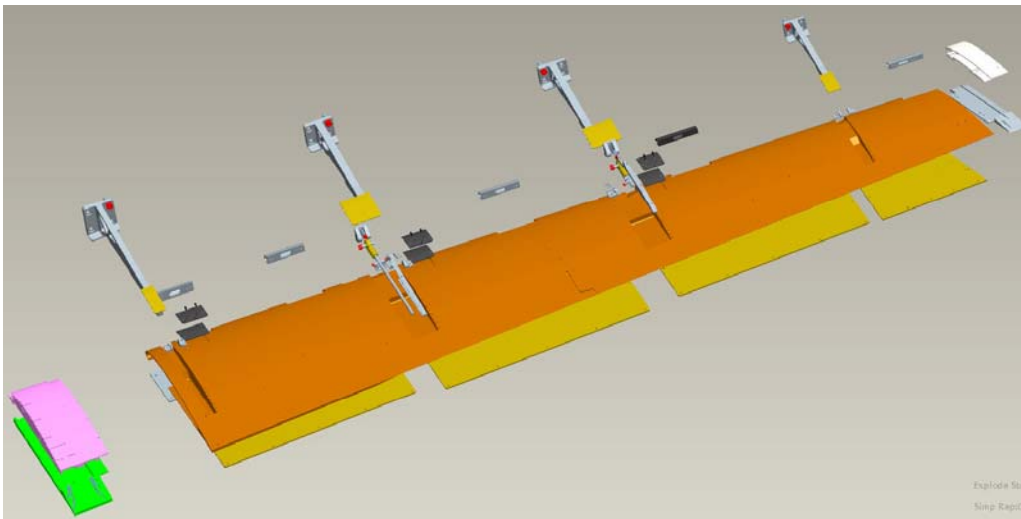
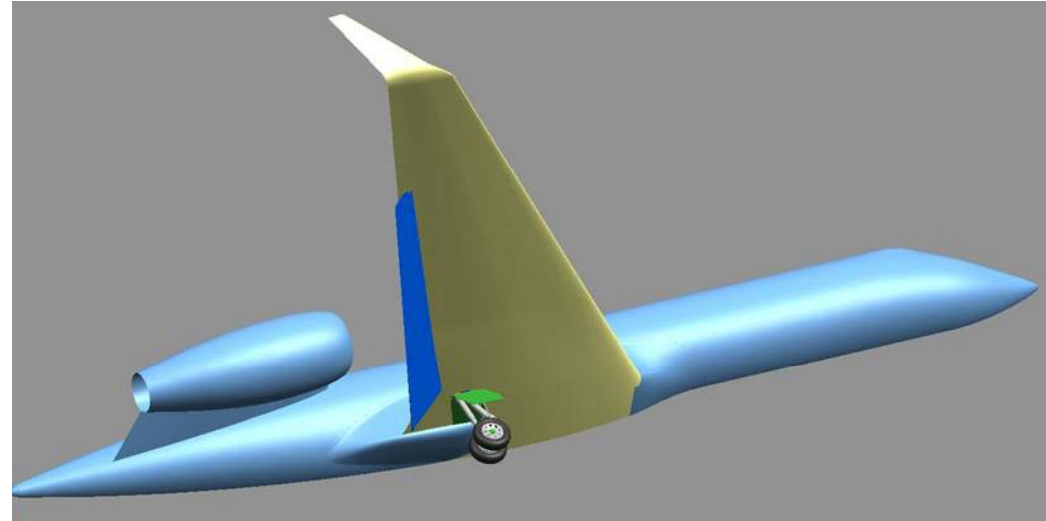

First Entry in Langley 14x22 Tunnel: Aerodynamic Test



- Aerodynamic testing began on 10-13-10
- Testing ended on 11-18-10
- First entry was focused on
 - Global forces (Lift and drag)
 - Steady and unsteady surface pressures
 - Overall aerodynamic characteristics
- Full analysis of measured data ongoing

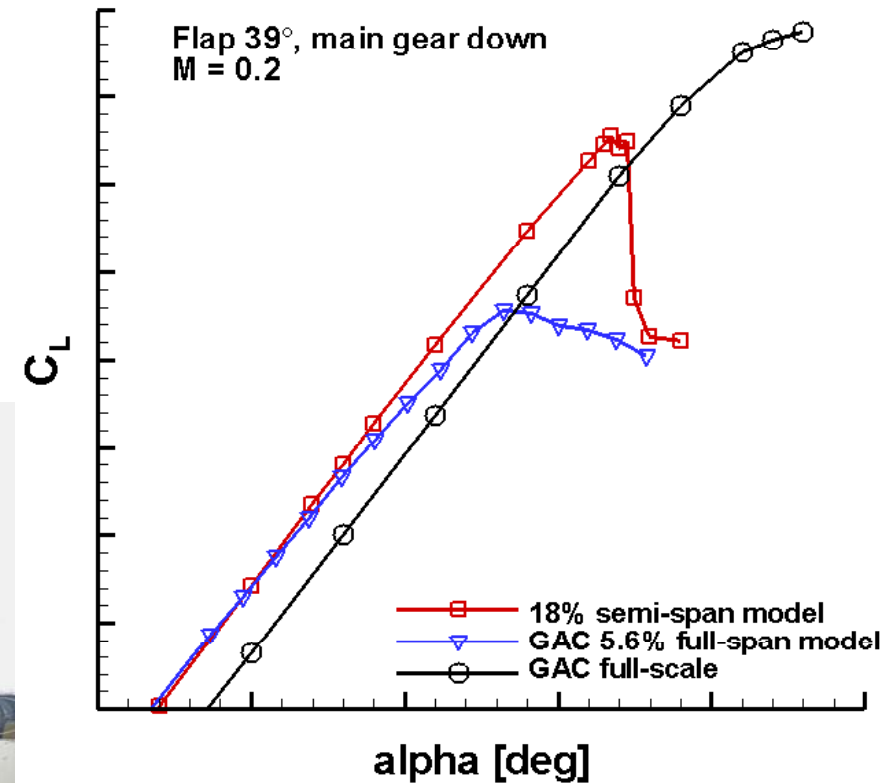

High-Fidelity Computational Simulations



- Provide insight on the nature of noise sources
- Guide physics based noise source modeling
- Advance airframe noise prediction capability
- Develop and evaluate noise reduction concepts

Flap Inboard Edge

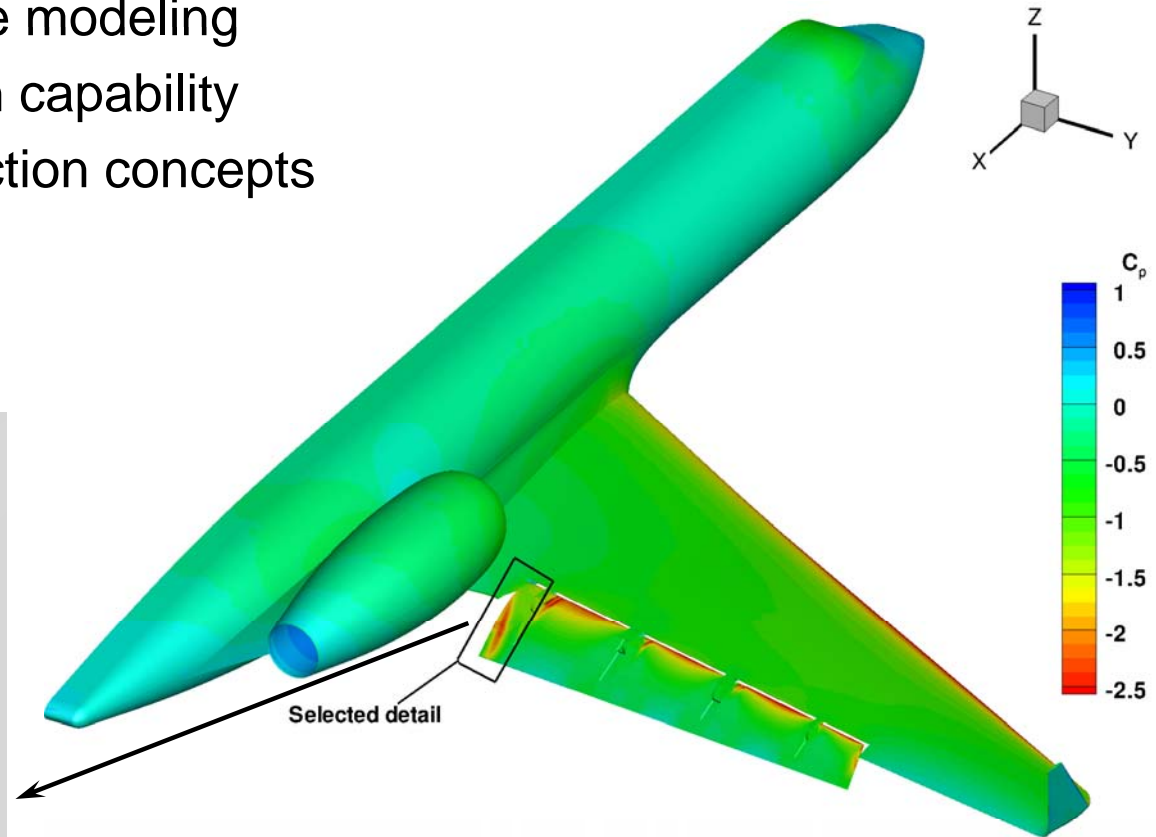
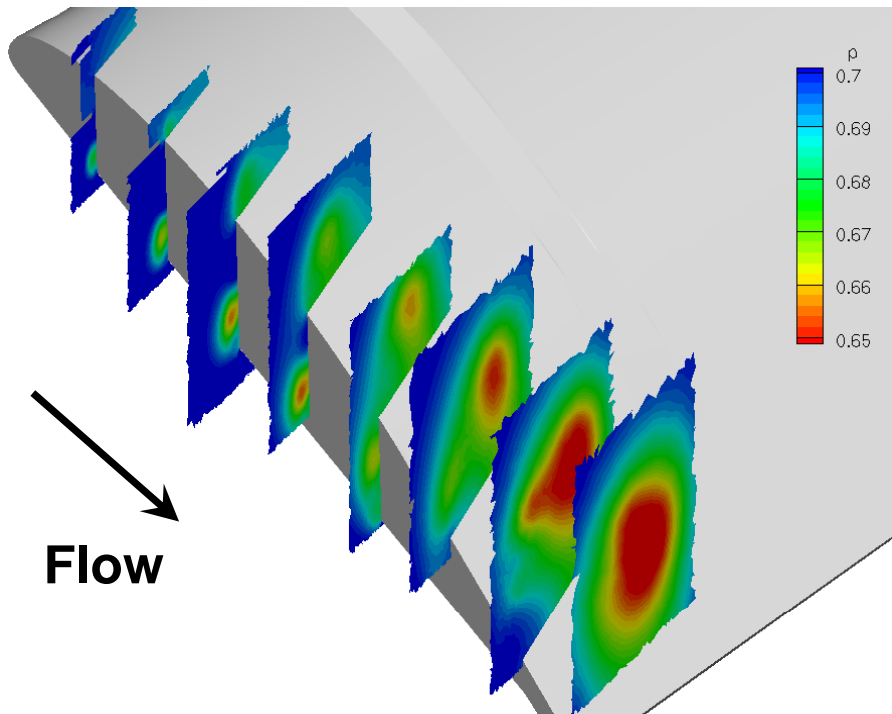

Noise Reduction Effort (Flap)



- **FLEXible Side-Edge Link (FLEXSEL)**
- FLEXSEL is different than Continuous Moldline Link
- Concept developed by a multi-disciplinary team at NASA Langley
- Effectiveness of concept to be validated/evaluated via simulations and testing

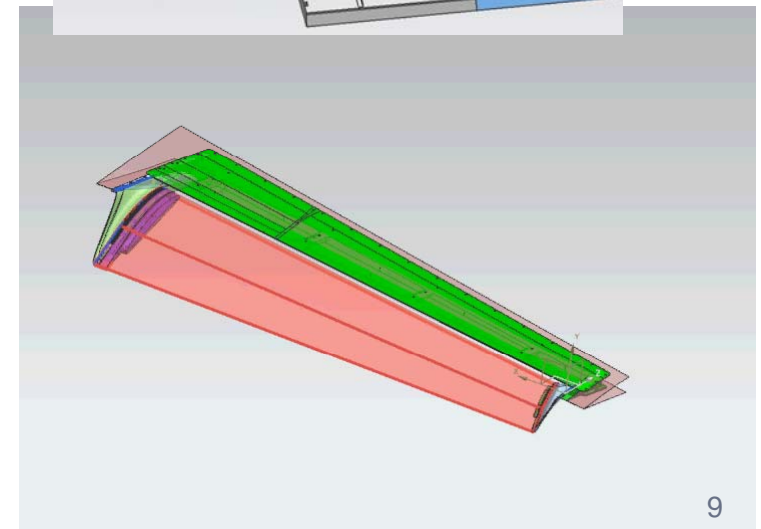
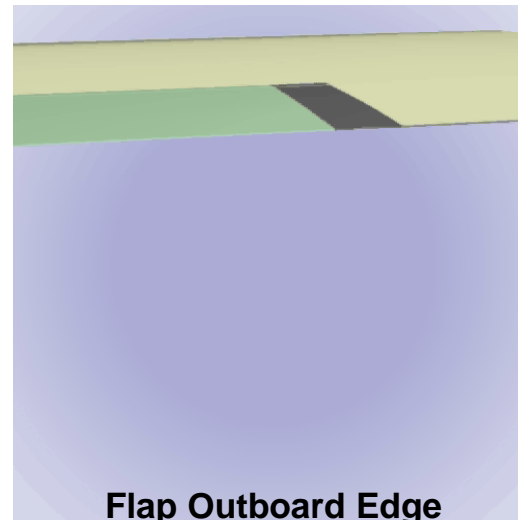
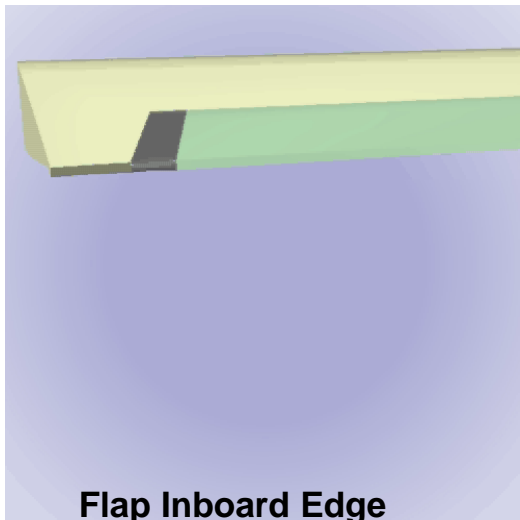
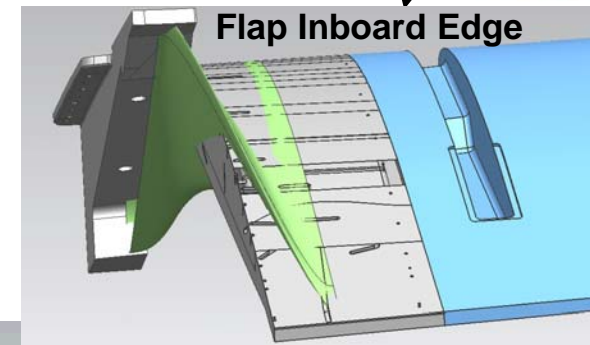
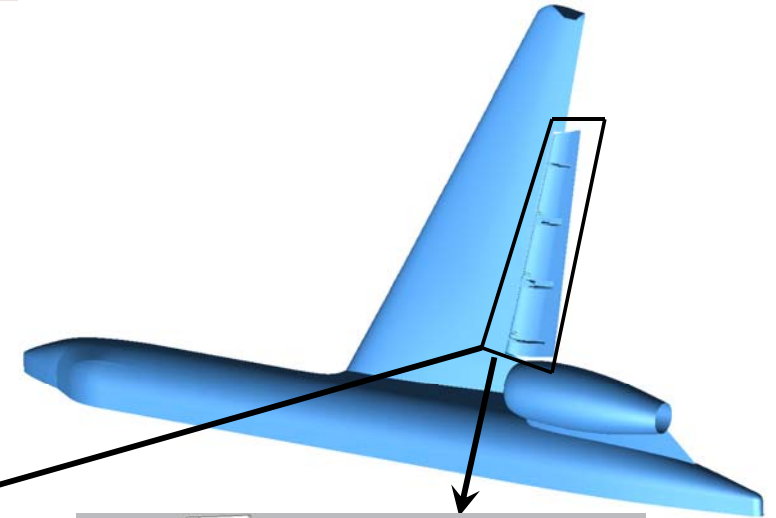
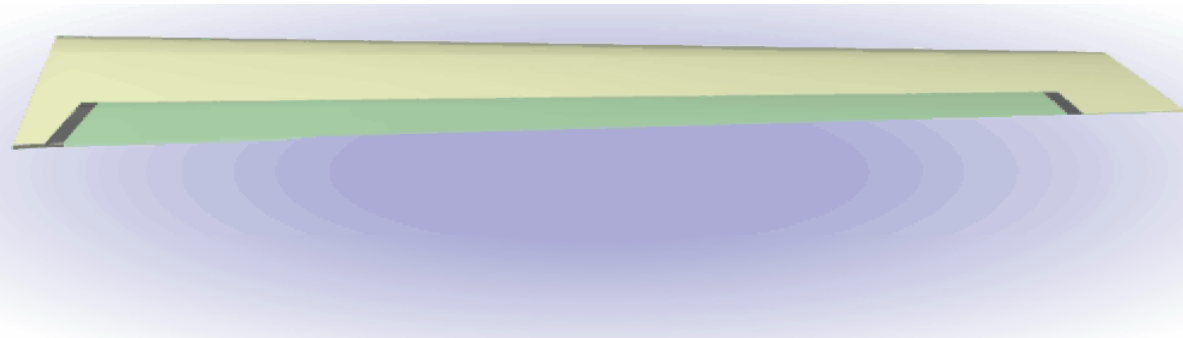

Noise Reduction Effort (Flap)



- Additional concepts to be tested:
 - Various shapes of FLEXSEL
 - Porous tip
 - Extended or locally reacting liners
 - Metallic rods
 - Others

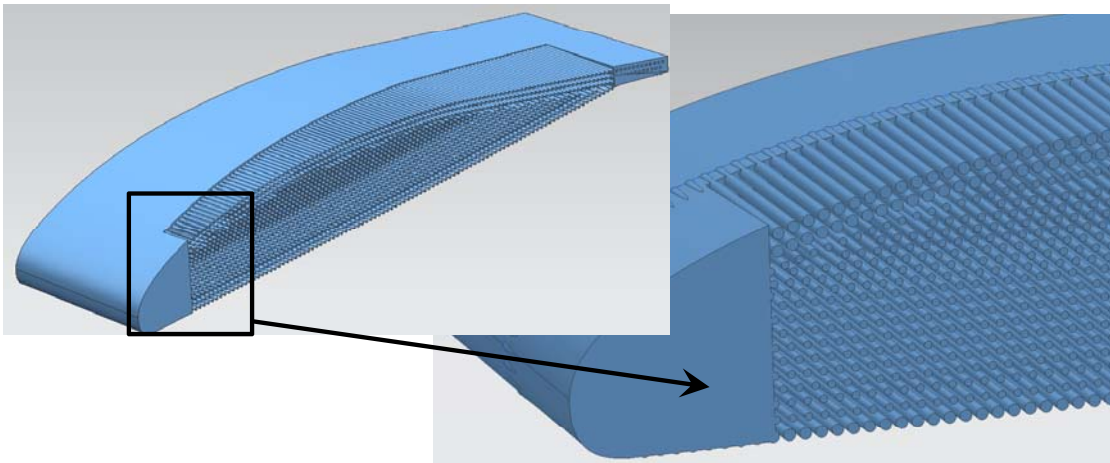
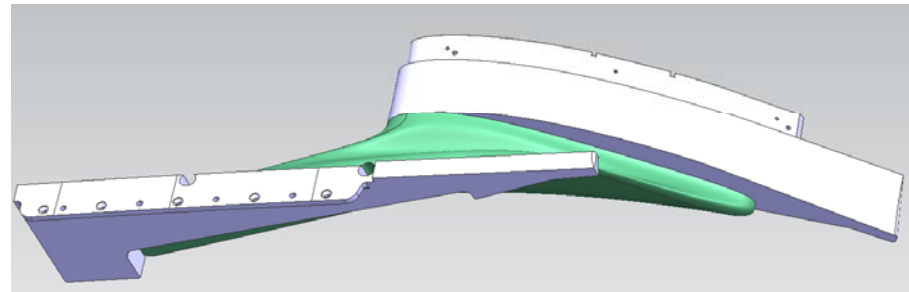
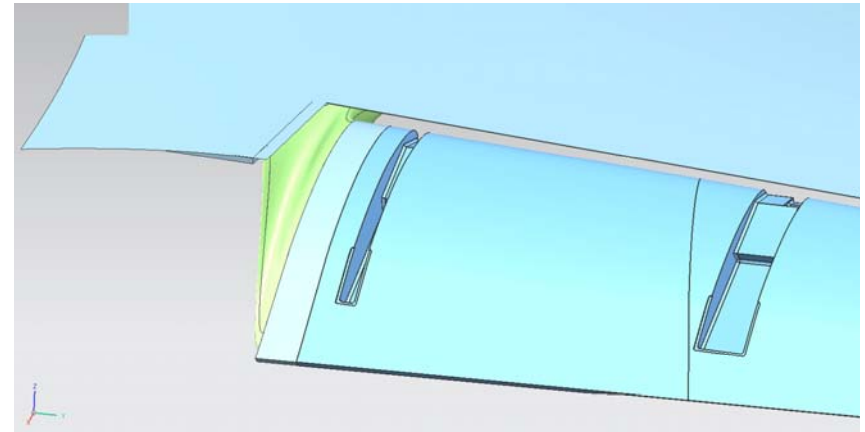

Noise Reduction Effort (Main Landing Gear)

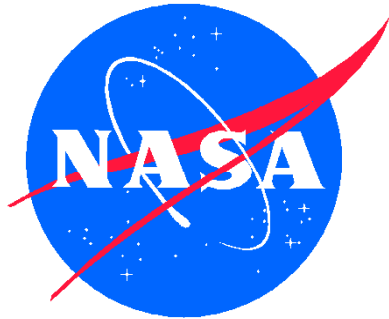
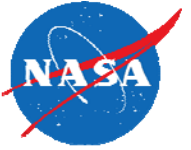

Additional Partners:

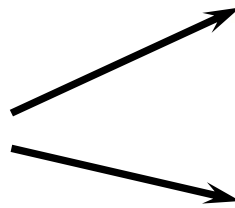

Noise Reduction Effort (Main Landing Gear)

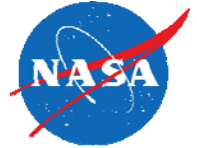

- Collective effort (NASA, Goodrich, Gulfstream, and Exa)
- Use of high-fidelity simulations as a design tool
- Concept development and refinement solely based on simulations
- NASA is to build and instrument the quiet gear design with funding from Goodrich (under way)
- Isolated quiet main gear design to be tested at VA Tech during April-May 2011 (validation of design methodology)
- Quiet main gear to be installed on the 18% G550 model and tested in Langley 14x22 tunnel during September 2011 (validation of concept in a relevant environment)

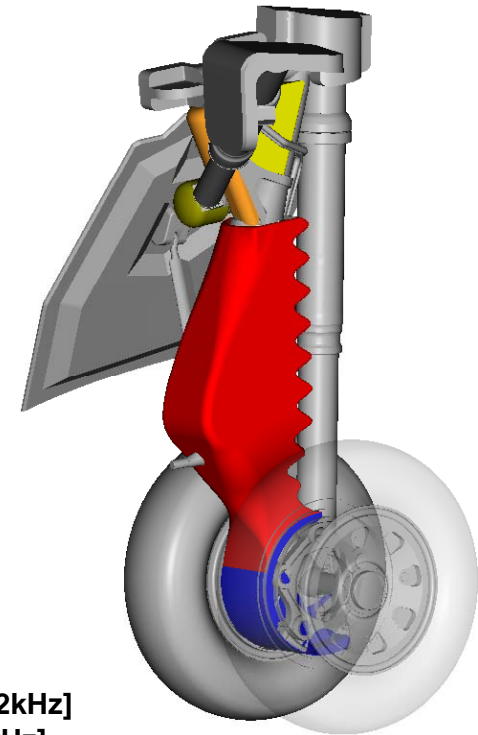

Baseline

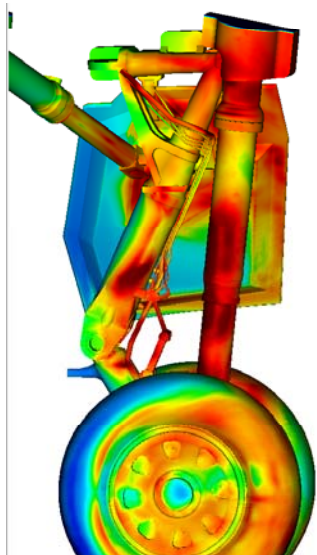

Case 1

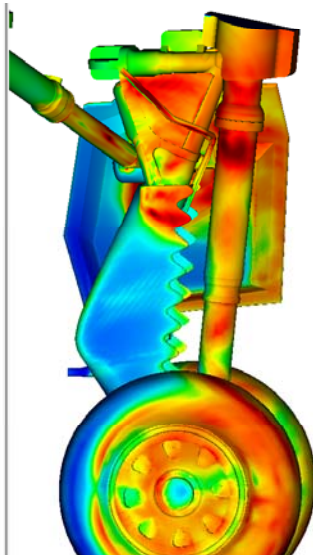

Case 2

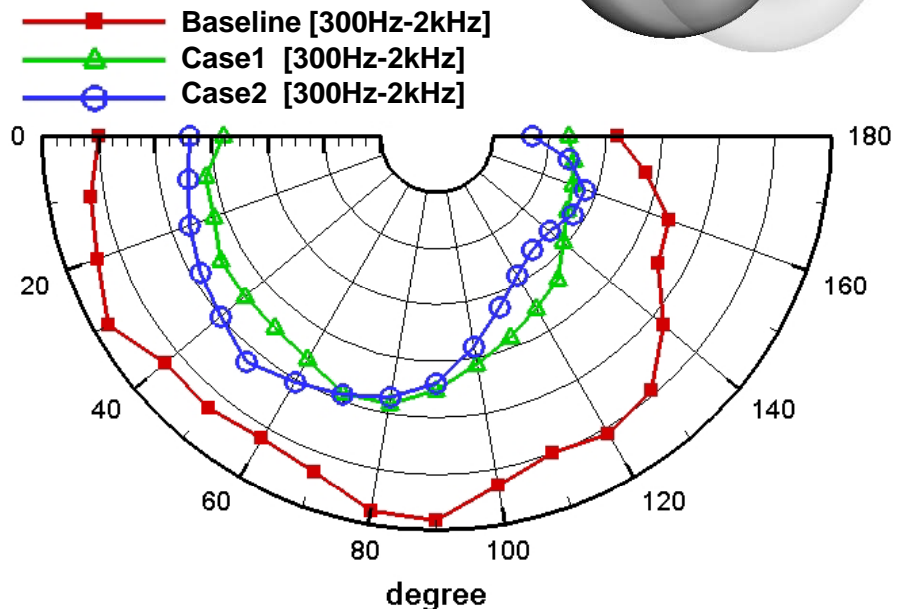
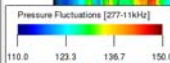
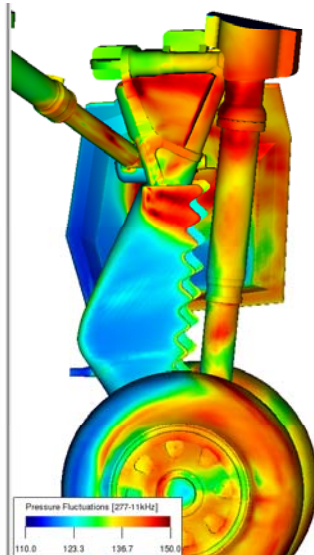

Planned Tests in 2011



- Aerodynamic flight test (G550 aircraft)
 - To be executed during spring 2011
 - Acquire steady surface pressures on wing and flap
 - Acquire unsteady surface pressures at flap edges, nose and main landing gear
 - Establish Reynolds number, geometric, and installation effects

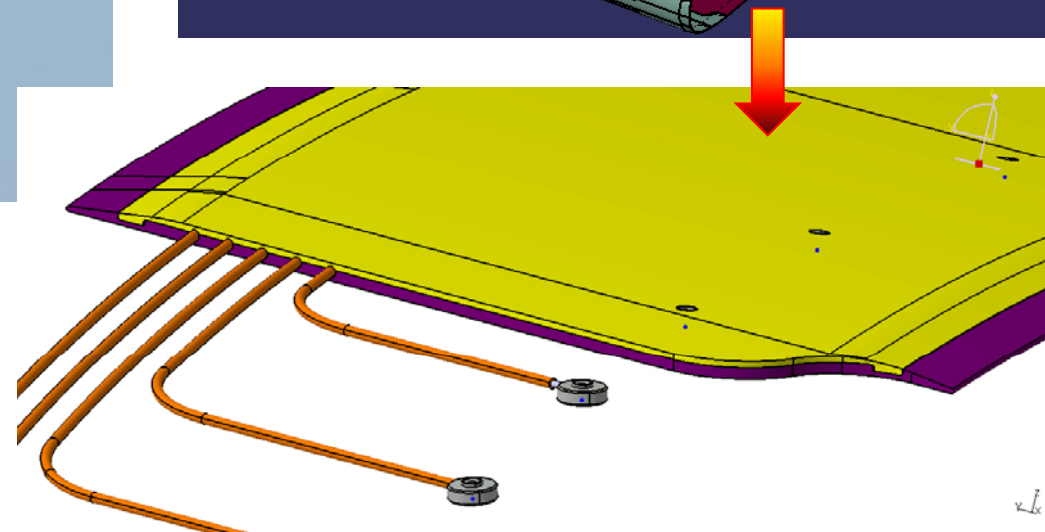
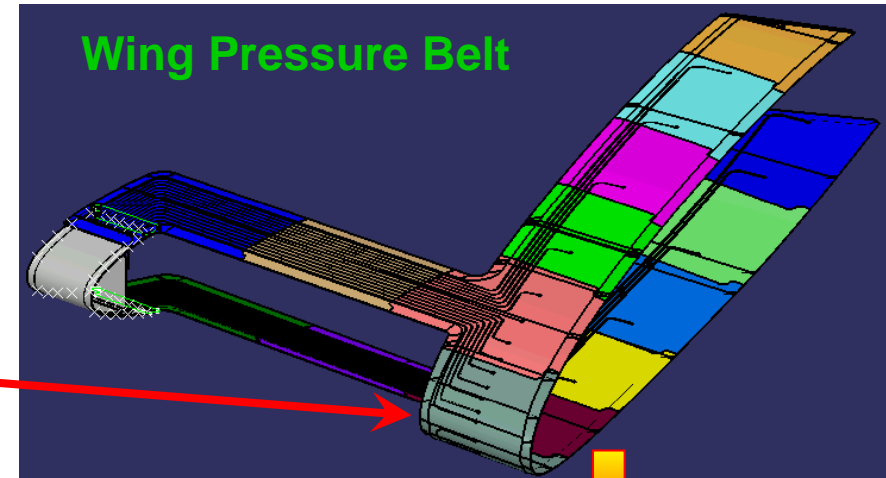

Planned Tests in 2011



- Second entry in Langley 14x22 tunnel
- This entry is dedicated to:
 - Limited repetition of aerodynamic measurements
 - Acoustic: Microphone array and free-field microphones
 - Off-surface flow: PIV
- Extensive evaluation of noise reduction concepts
 - Flap side-edges
 - Main landing gear
 - Gear-flap interaction

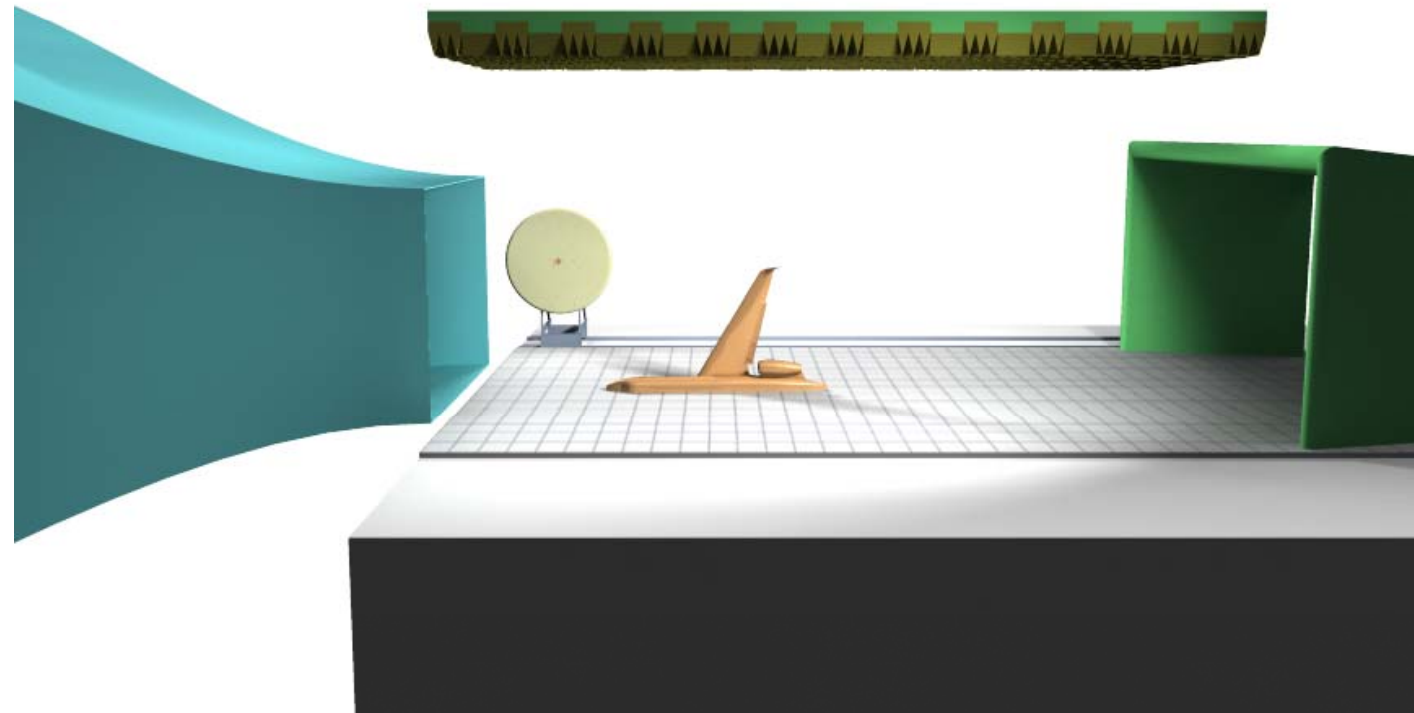

Closed Walls vs Open Walls Aerodynamics

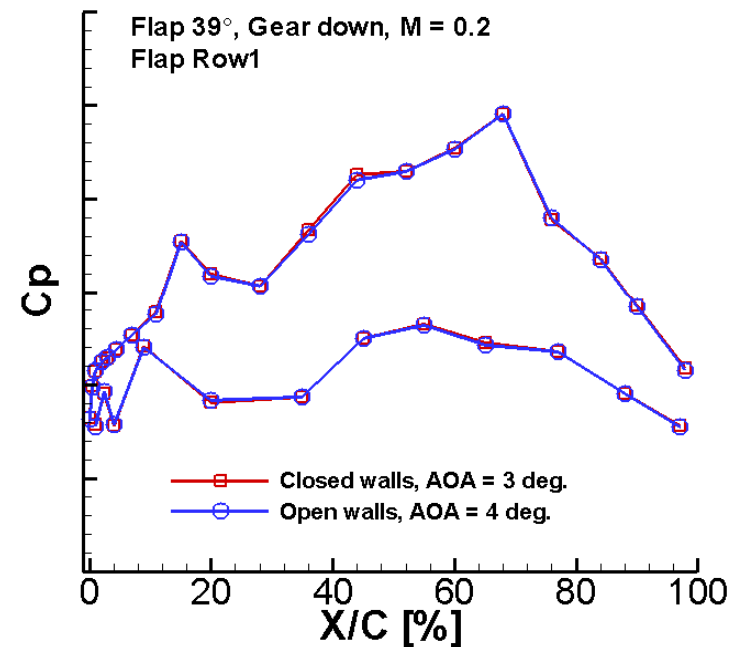
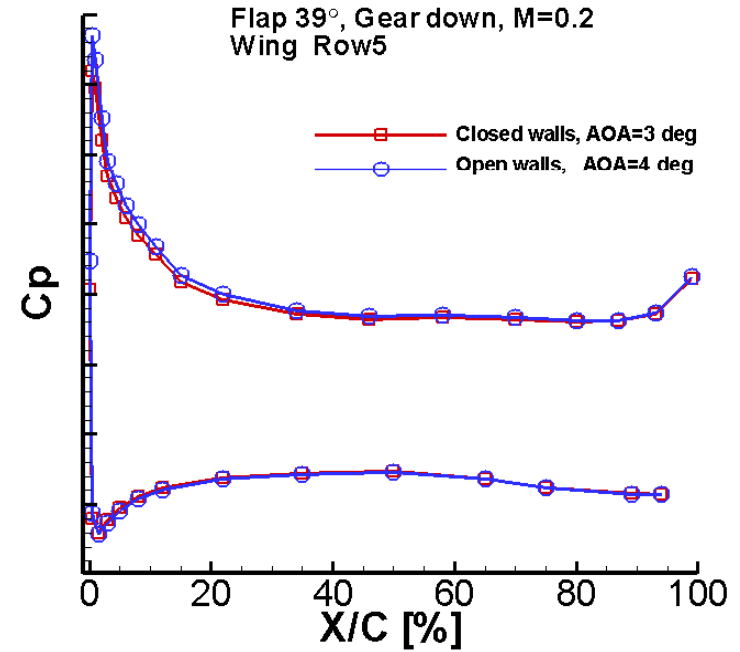
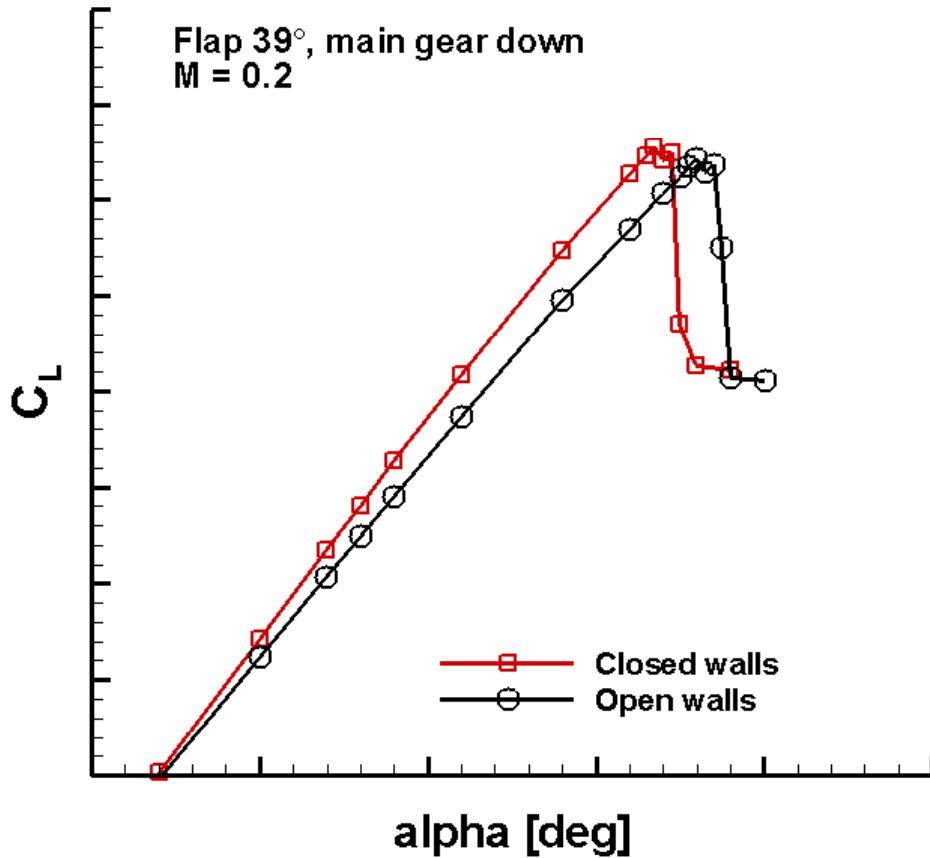

Future Tests Beyond 2011

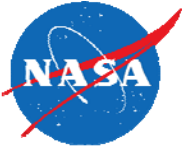

- Acoustic flight test: to be conducted during 2013 or 2014
- Down-select the most promising noise reduction technologies from 18% model tests and computational aeroacoustic analysis for flight testing
 - Which concepts to be tested based on collective decision by partners and available funding
 - Conduct flyover noise tests similar to 2006 airframe noise tests at Wallops
 - Determine the efficacy of the developed concepts in suppressing airframe noise

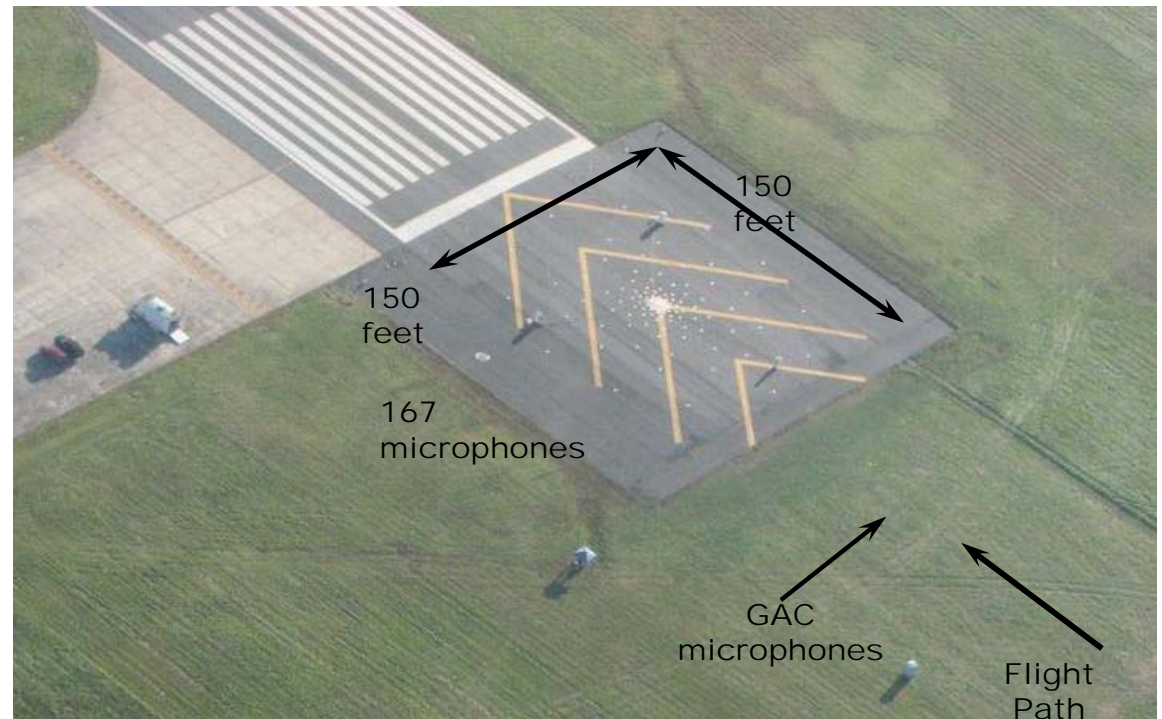

Summary



- An ambitious partnership program focused on airframe noise research has been established and is being executed systematically
- The aim of the partnership effort is to generate/acquire a high-quality airframe noise database that would guide the development of
 - Better noise source models
 - Efficient computational tools with predictive capabilities
 - Viable noise reduction concepts
- Delivery and aerodynamic testing of the 18% semi-span G550 model constitute the initial critical steps toward achieving these goals

Backup Slides



- Insert text here