

Receiver Signal to Noise Ratios for IPDA Lidars Using Sine-wave and Pulsed Laser Modulation and Direct Detections

Xiaoli Sun and James B. Abshire

NASA Goddard Space Flight Center
Solar System Division, Code 694
Greenbelt, Maryland 20771, USA
xiaoli.sun-1@nasa.gov

1. Introduction

Integrated path differential absorption (IPDA) lidar can be used to remotely measure the column density of gases in the path to a scattering target [1]. The total column gas molecular density can be derived from the ratio of the laser echo signal power with the laser wavelength on the gas absorption line (on-line) to that off the line (off-line). Both coherent detection and direct detection IPDA lidar have been used successfully in the past in horizontal path and airborne remote sensing measurements. However, for space based measurements, the signal propagation losses are often orders of magnitude higher and it is important to use the most efficient laser modulation and detection technique to minimize the average laser power and the electrical power from the spacecraft. This paper gives an analysis the receiver signal to noise ratio (SNR) of several laser modulation and detection techniques versus the average received laser power under similar operation environments.

Coherent detection [2] can give the best receiver performance when the local oscillator laser is relatively strong and the heterodyne mixing losses are negligible. Coherent detection has a high signal gain and a very narrow bandwidth for the background light and detector dark noise. However, coherent detection must maintain a high degree of coherence between the local oscillator laser and the received signal in both temporal and spatial modes. This often results in a high system complexity and low overall measurement efficiency. For measurements through atmosphere the coherence diameter of the received signal also limits the useful size of the receiver telescope.

Direct detection IPDA lidars are simpler to build and have fewer constraints on the transmitter and receiver components. They can use much larger size 'photon-bucket' type telescopes to reduce the demands on the laser transmitter. Here we consider the two most widely used direct detection IPDA lidar techniques. The first technique uses two CW seeder lasers, one on-line and one off-line that are intensity modulated by two different frequency sine-waves signals before being amplified by a common laser amplifier. The receiver uses narrowband amplitude demodulation, or lock-in, signal processing at the given laser modulation frequencies [3,4]. The laser transmitter operates in a quasi CW mode with the peak power equal to twice the average power. The on-line and off-line lasers can be transmitted at the same time without interference. Another direct detection technique uses a low duty cycle pulsed laser modulation [5,6] with the laser wavelengths alternating between on-line and off-line on successive pulses. The receiver uses time resolved detection and can also provide simultaneous target range measurement. With a lower laser duty cycle it requires a much higher peak laser power for the same average power.

2. IPDA Lidar Receivers

A coherent IPDA lidar [7] uses CW lasers and generates the intermediate frequency sinusoidal signal at the receiver from the coherent interference of the signal laser and local oscillator laser. The received signal is linear to the electromagnetic field of the incident laser light. The receiver frequency response is a linear combination of frequency response of the optical bandpass filter before the detector and that of the electrical filter after the detector. The latter is much narrower and effectively set the receiver

bandwidth. As a result, coherent detection receiver can reject almost all the background light and detector dark noise. The dominant noise source is the shot noise from the local oscillator laser. Figure 1 shows a block diagram of a coherent IPDA lidar receiver.

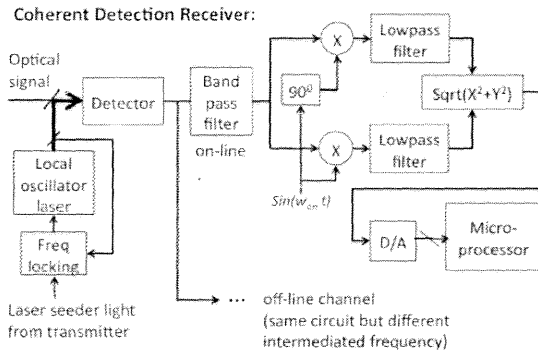

Figure 1. Simplified Block diagram of an IPDA lidar with a coherent receiver

The sine-wave modulation approach modulates the laser intensity with a sinusoidal signal with 50% duty cycle. The receiver, shown in Figure 2, is similar to the coherent detection receiver but without the local oscillator laser. The received signal is linear to intensity (square of the field) of the incident light. The overall frequency response is determined by the receiver electrical bandwidth but the magnitude of the noise is determined by the total incident optical power, which is proportional to the optical filter bandwidth. Neither the coherent nor sine-wave modulation approaches provides target range measurement and detect clouds. A separate laser ranging channel is needed to measure the path length.

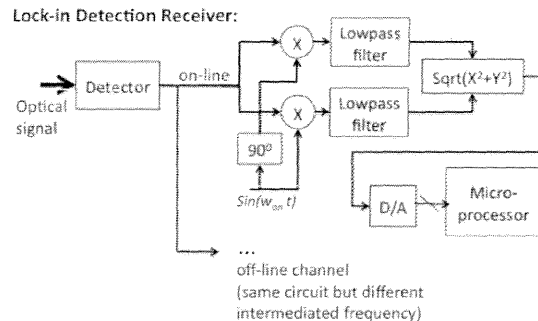

Figure 2. Block diagram of lock-in detection IPDA receiver for sinusoidal laser intensity modulated laser signal.

An IPDA lidar using pulsed modulation and a direct detection receiver can provide a range resolved gas absorption measurements and minimize the effects of background light by range gating. A block diagram of the receiver is shown in Figure 3. Figure 4 shows a comparison of the laser signal for the sinusoidal and pulsed modulation IPDA lidars.

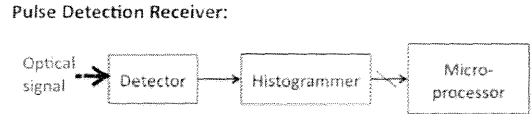
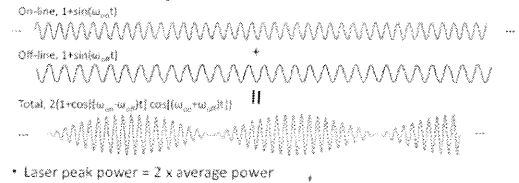

Figure 3. Block diagram of direct detection pulsed IPDA lidar.

Sinewave Laser Intensity Modulation:



Pulsed Laser Intensity Modulation:

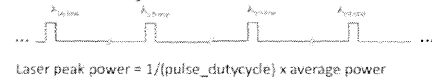

Figure 4. Laser modulation format for direct detection IPDA lidars.

3. Receiver SNR –Theory

3.1. Coherent IPDA Lidar

The mean and the standard deviation of the received signal for coherent IPDA lidar can be written as [2]

$$\mu_c = \frac{\eta_{det}}{hf} \cdot \eta_c \cdot \frac{\sqrt{\langle P_{sig} \rangle} \sqrt{\langle P_{LO} \rangle}}{\sqrt{N_\lambda}}$$

$$\sigma_c \approx \sqrt{2 \frac{\eta_{det}}{hf} \langle P_{LO} \rangle \left(\frac{1}{2T_{int}} \right)}$$

where η_{det} is the detector quantum efficiency, hf is the photon energy, η_c is the coherent mixing efficiency, $\langle P_{sig} \rangle$ and is the average received signal power, $\langle P_{LO} \rangle$ is the average local oscillator laser power, $N_\lambda=2$ is the

number of wavelengths, $1/2T_{\text{int}}$ is the receiver electrical noise bandwidth, and T_{int} is the receiver integration time.

The receiver signal to noise ratio can be written as

$$\begin{aligned} \text{SNR}_c &\equiv \frac{\mu_c}{\sigma_c} \\ &= \eta_c \cdot \frac{1}{\sqrt{N_\lambda}} \cdot \sqrt{\frac{\eta_{\text{det}}}{hf} \cdot \langle P_{\text{sig}} \rangle T_{\text{int}}} \\ &= \eta_c \cdot \frac{1}{\sqrt{N_\lambda}} \cdot \sqrt{\langle n_{\text{sig}} \rangle} \end{aligned}$$

with $\langle n_{\text{sig}} \rangle$ the average number of detected signal photons over the receiver integration time. Coherent detection can be efficient and reaches the quantum limit by a factor of the coherent mixing efficiency.

3.2. Sine-wave Modulation IPDA Lidar

The mean and standard deviation of the signal at for a sine-wave modulation lock-in detection IPDA lidar can be expressed as,

$$\begin{aligned} \mu_L &= \frac{1}{2} \cdot \frac{\eta_{\text{det}}}{hf} \cdot \left[\frac{\langle P_{\text{sig}} \rangle_{\text{sin}}}{N_\lambda} \right] \\ \sigma_L &\approx \sqrt{2 \left[\frac{\eta_{\text{det}}}{hf} \cdot \left(\langle P_{\text{sig}} \rangle_{\text{sin}} + P_{\text{bg}} \right) + \frac{I_{\text{dark}}}{q} \right] \left(\frac{1}{2T_{\text{int}}} \right)} \cdot \sqrt{2} \end{aligned}$$

where $\langle P_{\text{bg}} \rangle$ is the CW background power, I_{dark} is the detector dark current, and q is the electron charge. The receiver shot noise was derived from frequency domain [2]. The receiver SNR can be expressed as

$$\text{SNR}_{\text{sin}} = \frac{\frac{1}{2\sqrt{2}} \cdot \frac{\eta_{\text{det}}}{hf} \cdot \langle P_{\text{sig}} \rangle_{\text{sin}}}{\sqrt{\frac{\eta_{\text{det}}}{hf} \cdot \left(\langle P_{\text{sig}} \rangle_{\text{sin}} + P_{\text{bg}} \right) + \frac{I_{\text{dark}}}{q}}} \cdot \sqrt{T_{\text{int}}}$$

3.3. Pulsed IPDA Lidar

Assuming single photon detection, the mean and standard deviation of the received signal for a pulsed direct detection IPDA lidar can be expressed as

$$\begin{aligned} \mu_p &= \left(\frac{f_{\text{pulses}} T_{\text{int}}}{N_\lambda} \right) \frac{\eta_{\text{det}}}{hf} \left(\langle P_{\text{sig}} \rangle_{\text{pulsed}} \frac{1}{f_{\text{pulse}}} \right) \\ \sigma_p &= \sqrt{\left(\frac{f_{\text{pulses}} T_{\text{int}}}{N_\lambda} \right) \frac{\eta_{\text{det}}}{hf} \left(\left(\langle P_{\text{sig}} \rangle_{\text{pulsed}} \frac{1}{f_{\text{pulse}}} \right) + P_{\text{bg}} \tau_{\text{pw}} + \frac{I_{\text{dark}} \tau_{\text{pw}}}{q} \right)} \end{aligned}$$

where τ_{pw} is the pulse width and f_{pulses} is the pulse rate.

$$\text{SNR}_{\text{pulsed}} = \frac{\frac{1}{\sqrt{N_\lambda}} \cdot \frac{\eta_{\text{det}}}{hf} \langle P_{\text{sig}} \rangle_{\text{pulsed}} \sqrt{T_{\text{int}}}}{\sqrt{\frac{\eta_{\text{det}}}{hf} \left(\langle P_{\text{sig}} \rangle_{\text{pulsed}} + \alpha_{\text{dry}} P_{\text{bg}} \right) + \alpha_{\text{dry}} \frac{I_{\text{dark}}}{q}}}$$

with $\alpha_{\text{dry}} = \tau_{\text{pw}} f_{\text{pulse}}$ the duty cycle of the signal pulses. Compare to the sine-wave modulation, pulsed modulation and detection reduces the effect of background light and detector dark noise by the pulse duty cycle.

4. Comparison of Calculated SNR

Under ideal conditions when the background light and detector dark noise are zero, the ratio of the SNRs of the sine-wave modulation lock-in detection to that of the coherent detection becomes

$$\begin{aligned} \frac{\text{SNR}_{\text{sin}}}{\text{SNR}_c} &= \frac{1}{2\sqrt{2} \sqrt{N_\lambda} \eta_c} \\ \frac{\text{SNR}_{\text{pulse}}}{\text{SNR}_c} &= \frac{1}{\eta_c} \end{aligned}$$

Sine-wave modulation lock-in detection gives a lower SNR than coherent detection because of the unipolar laser intensity modulation. One half the laser power is not used to convey information but to maintain a proper bias. On the other hand, photon counting pulse detection can reach the same SNR as the coherent detection, because, under ideal conditions, the receiver SNR is fundamentally limited by the number of detected signal photons but not the modulation formats and the signal processing techniques.

The ratio of SNRs between the lock-in and pulsed direct detection at a given background

light and detector dark noise can be written as

$$\frac{SNR_{pulsed}}{SNR_{sin}} = \frac{\sqrt{\frac{\eta_{det}}{hf} \langle P_{sig} \rangle + \left(\frac{\eta_{det}}{hf} P_{bg} + \frac{I_{dark}}{q} \right)}}{\sqrt{\frac{\eta_{det}}{hf} \langle P_{sig} \rangle + \alpha_{dry} \left(\frac{\eta_{det}}{hf} P_{bg} + \frac{I_{dark}}{q} \right)}} \geq 4 \quad \text{for } N_{\lambda} = 2 \quad (\text{online \& offline only})$$

Unver zero background light and detector dark noise, the ratio of the average signal power to achieve the same SNR is given by

$$\frac{\langle P_{sig} \rangle_{pulsed}}{\langle P_{sig} \rangle_{sin}} = \left(\frac{1}{2\sqrt{2} \cdot \sqrt{N_{\lambda}}} \right)^2 = \frac{1}{8N_{\lambda}} = \frac{1}{16} \quad \text{for } (N_{\lambda} = 2)$$

5. Measurements of Direct Detection Receiver SNRs

We conducted laboratory experiments to measure the SNRs for lock-in and pulsed direct detection under similar conditions. The current to a 1060 nm laser diode was modulated by an arbitrary waveform generator, which modulated the laser's output power in either sine-wave or pulses. A near infrared photomultiplier was used as photon counting detector. For lock-in detection, an oscilloscope was used after the detector to record the analog waveforms into a PC for the signal processing. A set of bandpass filters were used before the oscilloscope to avoid aliasing. For pulsed detection a multichannel scaler was used as a time resolved histogrammer.

Figure 5 shows the measurement results along with the calculations given in the previous section. The parameter values used in the experiments are also listed in Table 1.

6. Summary and Conclusions

The measurements agreed well with theory for sine-wave and pulsed modulation. At high signal conditions, the performance was limited by signal shot noise. In this region for the same received power the pulsed SNR is

4 times higher that of sine-wave modulation. It also shows that the pulsed modulation required roughly 1/16 the average laser power to achieve the same SNR compared to sine-wave modulation. The performance differences become larger at lower signal levels and for higher background. More details about the derivation and experiment will be described in the presentation.

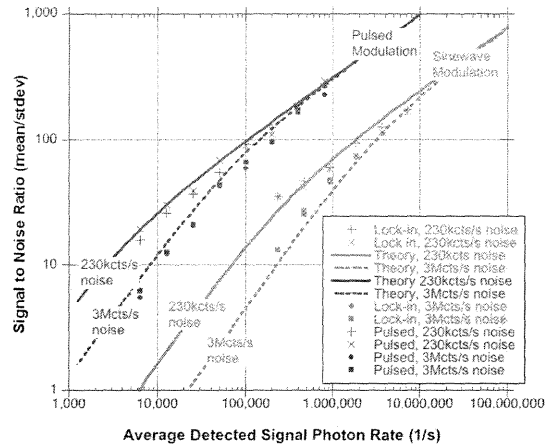

Figure 5. Measurement of the receiver SNR for both pulse and lock-in detection (symbols) along with the theoretical calculations (lines).

Table 1 - Experiment Parameters:

Laser: 1060 nm laser diode, intensity modulated by arbitrary waveform modulator
Detector: Hamamatsu H10330-75 PMT used in photon counting configuration

Pulsed Modulation:

Pulse width: 1 μ sec, rectangular shape
Pulse rate: 10 kHz, alternating between on-line and off-line
Receiver integration time: $T_{int} = 0.2$ sec

Sinewave Modulation Lock-in Detection:

Sinewave frequency, on-line: 50 kHz
Sinewave frequency, off-line: 51 kHz
Anti aliasing filter before oscilloscope: 10 kHz bandpass
Lowpass filter type: 9th order Bessel
Lowpass filter bandwidth: 5 Hz

7. Acknowledgements

This work was supported by NASA Earth Science Technology Office (ESTO) Instrument Incubator Program (IIP).

8. References

1. R. M. Measures, *Laser Remote Sensing, Fundamentals and Applications*, Krieger, Malabar Florida, 1992.
2. R. M. Gagliardi and S. Karp, *Optical Communications*, Ch. 4, 2nd edition, John Wiley and Sons, New York, 1995.
3. J. Pruitt *et al.*, 'High-speed CW lidar retrieval using spectral lock-in algorithm,' *SPIE* 5154, 2003.
4. S. Kameyama, et al., "Development of 1.6 μm continuous-wave modulation hard-target differential absorption lidar system for CO₂ sensing," *Opt. Lett.* **34**, 1513-1515, 2009.
5. J. B. Abshire *et al.*, 'Pulsed airborne lidar measurements of atmospheric CO₂ column absorption,' *Tellus Series B*, 2010.
6. J. B. Abshire *et al.*, "A lidar approach to measure CO₂ concentrations from space for the ASCENDS Mission", Proc. SPIE 7832, 78320D, 2010; doi:10.1117/12.8685.
7. G. D. Spiers *et al.*, "Atmospheric CO₂ measurements with a 2 μm airborne laser absorption spectrometer employing coherent detection," *Appl. Opt.* **50**, 2098-2111, 2011.