

NASA/TM—2011-217040



NEXT Propellant Management System Integration With Multiple Ion Thrusters

James S. Sovey
Alphaport, Inc., Cleveland, Ohio

George C. Soulas and Daniel A. Herman
Glenn Research Center, Cleveland, Ohio

NASA STI Program . . . in Profile

Since its founding, NASA has been dedicated to the advancement of aeronautics and space science. The NASA Scientific and Technical Information (STI) program plays a key part in helping NASA maintain this important role.

The NASA STI Program operates under the auspices of the Agency Chief Information Officer. It collects, organizes, provides for archiving, and disseminates NASA's STI. The NASA STI program provides access to the NASA Aeronautics and Space Database and its public interface, the NASA Technical Reports Server, thus providing one of the largest collections of aeronautical and space science STI in the world. Results are published in both non-NASA channels and by NASA in the NASA STI Report Series, which includes the following report types:

- **TECHNICAL PUBLICATION.** Reports of completed research or a major significant phase of research that present the results of NASA programs and include extensive data or theoretical analysis. Includes compilations of significant scientific and technical data and information deemed to be of continuing reference value. NASA counterpart of peer-reviewed formal professional papers but has less stringent limitations on manuscript length and extent of graphic presentations.
- **TECHNICAL MEMORANDUM.** Scientific and technical findings that are preliminary or of specialized interest, e.g., quick release reports, working papers, and bibliographies that contain minimal annotation. Does not contain extensive analysis.
- **CONTRACTOR REPORT.** Scientific and technical findings by NASA-sponsored contractors and grantees.

- **CONFERENCE PUBLICATION.** Collected papers from scientific and technical conferences, symposia, seminars, or other meetings sponsored or cosponsored by NASA.
- **SPECIAL PUBLICATION.** Scientific, technical, or historical information from NASA programs, projects, and missions, often concerned with subjects having substantial public interest.
- **TECHNICAL TRANSLATION.** English-language translations of foreign scientific and technical material pertinent to NASA's mission.

Specialized services also include creating custom thesauri, building customized databases, organizing and publishing research results.

For more information about the NASA STI program, see the following:

- Access the NASA STI program home page at <http://www.sti.nasa.gov>
- E-mail your question via the Internet to help@sti.nasa.gov
- Fax your question to the NASA STI Help Desk at 443-757-5803
- Telephone the NASA STI Help Desk at 443-757-5802
- Write to:
NASA Center for AeroSpace Information (CASI)
7115 Standard Drive
Hanover, MD 21076-1320

NASA/TM—2011-217040



NEXT Propellant Management System Integration With Multiple Ion Thrusters

James S. Sovey
Alphaport, Inc., Cleveland, Ohio

George C. Soulas and Daniel A. Herman
Glenn Research Center, Cleveland, Ohio

National Aeronautics and
Space Administration

Glenn Research Center
Cleveland, Ohio 44135

May 2011

Acknowledgments

The authors would like to acknowledge the support of the In-Space Propulsion project managed by the NASA Glenn Research Center.

Trade names and trademarks are used in this report for identification only. Their usage does not constitute an official endorsement, either expressed or implied, by the National Aeronautics and Space Administration.

Level of Review: This material has been technically reviewed by technical management.

Available from

NASA Center for Aerospace Information
7115 Standard Drive
Hanover, MD 21076-1320

National Technical Information Service
5301 Shawnee Road
Alexandria, VA 22312

Available electronically at <http://www.sti.nasa.gov>

NEXT Propellant Management System Integration With Multiple Ion Thrusters

James S. Sovey
Alphaport, Inc.
Cleveland, Ohio 44135

George C. Soulas and Daniel A. Herman
National Aeronautics and Space Administration
Glenn Research Center
Cleveland, Ohio 44135

Abstract

As a critical part of the NEXT test validation process, a multiple-string integration test was performed on the NEXT propellant management system and ion thrusters. The objectives of this test were to verify that the PMS is capable of providing stable flow control to multiple thrusters operating over the NEXT system throttling range and to demonstrate to potential users that the NEXT PMS is ready for transition to flight. A test plan was developed for the sub-system integration test for verification of PMS and thruster system performance and functionality requirements. Propellant management system calibrations were checked during the single and multi-thruster testing. The low pressure assembly total flow rates to the thruster(s) were within 1.4 percent of the calibrated support equipment flow rates. The inlet pressures to the main, cathode, and neutralizer ports of Thruster PM1R were measured as the PMS operated in 1-thruster, 2-thruster, and 3-thruster configurations. It was found that the inlet pressures to Thruster PM1R for 2-thruster and 3-thruster operation as well as single thruster operation with the PMS compare very favorably indicating that flow rates to Thruster PM1R were similar in all cases. Characterizations of discharge losses, accelerator grid current, and neutralizer performance were performed as more operating thrusters were added to the PMS. There were no variations in these parameters as thrusters were throttled and single and multiple thruster operations were conducted. The propellant management system power consumption was at a fixed voltage to the DCIU and a fixed thermal throttle temperature of 75 °C. The total power consumed by the PMS was 10.0, 17.9, and 25.2 W, respectively, for single, 2-thruster, and 3-thruster operation with the PMS. These sub-system integration tests of the PMS, the DCIU Simulator, and multiple thrusters addressed, in part, the NEXT PMS and propulsion system performance and functionality requirements.

Nomenclature

DCA	discharge cathode assembly
DCIU	digital control interface unit
FCD	flow control device
GRC	Glenn Research Center
HPA	high pressure assembly
LPA	low pressure assembly
MFC	mass flow controller
NCA	neutralizer cathode assembly
NEXT	NASA's Evolutionary Xenon Thruster
NSTAR	NASA's Solar Electric Propulsion Technology Application Readiness
PFCV	proportional flow control valve

PM	prototype model
PMS	propellant management system
RTD	resistance temperature detector
SSIT	single string integration test
VF	vacuum facility
XFSE	xenon feed support equipment

Introduction

The NASA Glenn Research Center (GRC) is responsible for the development of NASA's Evolutionary Xenon Thruster (NEXT) ion propulsion system (Refs. 1 and 2). This system is a next generation ion propulsion system to follow the successful NASA's Solar Electric Propulsion Technology Applications Readiness (NSTAR) ion propulsion system that propelled NASA's Deep Space 1 spacecraft and is presently propelling the Dawn spacecraft (Refs. 3 and 4). Propulsion system elements under development by the NEXT program include a high-performance, 7 kW ion thruster; a modular, high-efficiency 7 kW power processor unit; a highly flexible advanced xenon propellant management system; and a compact, light-weight thruster gimbal. This design approach was selected to provide future NASA science missions with the greatest value in mission performance benefit at a low total development cost (Ref. 1).

As a critical element of the NEXT test validation process, a multiple string integration test of the propellant management system (PMS) and three operational thrusters was performed. The objectives of this test were to verify that the PMS is capable of providing stable flow control to single or multiple thrusters operating over the system throttling range and to demonstrate to potential users that the NEXT PMS is ready for transition to flight. Propulsion system elements included in this integration test were:

- an advanced engineering model ion thruster, labeled PM1R, that was manufactured by the NEXT program's industrial partner Aerojet and successfully completed environmental testing at qualification levels (Refs. 5 and 6);
- two engineering model ion thrusters (EM1, EM5) that were previously employed in the NEXT Multi-Thruster Engineering Demonstration Test (Ref. 7);
- a propellant management system that was designed and manufactured by the NEXT program's industrial partner Aerojet and successfully completed environmental testing at qualification levels (Refs. 8 and 9);
- three power consoles that were previously employed in the NEXT Multi-Thruster Engineering Demonstration Test (Refs. 7 and 10);
- a breadboard model digital control interface unit (DCIU) that acted as a test console for performing ground-based testing of the propulsion system, and was designed and manufactured by the NEXT program's industrial partner Aerojet (Ref. 9).

This paper will present test results of the NEXT PMS multiple string integration test using the propulsion system elements described in this section.

Propulsion System Element Descriptions

The following sections describe the propulsion system elements tested during the PMS integration test. They include the ion thruster, the propellant management system, and the DCIU simulator. Also included in a separate section is a description of the propulsion system interfaces.

Ion Thrusters

The advanced engineering model thruster (previously labeled prototype model, or PM) used in the integration test is labeled PM1R, and is shown in Figure 1 along with Thrusters EM1 and EM5. The thruster was developed by NASA GRC, and the technology was transferred to Aerojet, who designed and built this flight-like thruster. The PM thruster design is functionally identical to the thruster developed by NASA (Ref. 11). The PM design improved upon the GRC thruster design with emphasis on surviving vibration and thermal environments and on reduced thruster mass. Manufacturability was also improved with this new design. The PM thruster design included innovative coatings to increase emissivity for enhanced thermal margin, more uniform ion optics aperture diameters with much shallower cusps, a 36 cm beam extraction diameter to reduce edge aperture erosion, and graphite discharge cathode keeper to mitigate keeper erosion. A more detailed discussion of the PM thruster design can be found in Reference 5.

The PM1R thruster is a reworked version of the PM1 thruster that was initially performance tested in the summer of 2006 (Ref. 12). The PM1R thruster successfully completed environmental testing and single-string testing. Detailed results can be found in References 6, 13, and 14.

Also shown in Figure 1 are NEXT engineering model thrusters, EM1 and EM5. These thrusters were used in the multi-thruster array demonstration test (Ref. 7) and were also employed in this PMS integration test. General thruster configurations are shown in Table 1. Thrusters EM1 and EM5 are similar to the EM thruster tested for 2000 hr in 2003 (Ref. 15). The EM thrusters utilize a 40 cm beam extraction diameter. These thrusters use a hollow cathode electron emitter and a semi-conic chamber with a ring-cusp magnetic circuit employing high strength rare earth magnets. Compact high voltage propellant isolators with voltage isolation capability greater than 1800 V are also used on the EM thrusters. The neutralizer cathode assembly is mechanically similar to the Hollow Cathode Assembly used on the International Space Station Plasma Contactor (Ref. 16).

An abbreviated version of the NEXT thruster throttle table is shown in Table 2. Predicted performance for several throttle points used in this investigation is shown for power levels ranging from 0.55 to 6.86 kW.



Figure 1.—Photographs of NEXT ion thrusters PM1R, EM1, and EM5 (from left to right).

TABLE 1.—CONFIGURATION OF THE THRUSTERS USED WITH THE NEXT PMS

Component/Assembly	PM1R	EM1	EM5
DCA	Pre-operated in single string integration test	Pre-operated in multi-thruster array test	Pre-operated in multi-thruster array test
NCA	Pre-operated in single string integration test	Pre-operated in multi-thruster array test	Pre-operated in multi-thruster array test
Ion optics (Beam dia.)	Pre-operated in single string integration test (36 cm)	Pre-operated in multi-thruster array test (40 cm)	Pre-operated in multi-thruster array test (40 cm)
Discharge chamber	Pre-operated in single string integration test	Pre-operated in multi-thruster array test	Pre-operated in multi-thruster array test

TABLE 2.—THRUSTER THROTTLE TABLE WITH PREDICTED THRUST AND SPECIFIC IMPULSE FOR RELEVANT THROTTLE POINTS

[All neutralizer keeper currents are 3.0 A.]

Nominal thruster power, kW	Beam current, A	Beam supply voltage, V	Accel. voltage, V	Main flow rate, sccm	Cathode flow rate, sccm	Neut. flow rate, sccm	Thrust, mN	Specific impulse, s
6.86	3.52	1800	-210	49.6	4.87	4.01	236	4190
4.74	3.52	1179	-200	49.6	4.87	4.01	192	3390
3.66	2.70	1179	-200	37.6	4.26	3.50	147	3360
2.78	2.00	1179	-200	25.8	3.87	2.50	108	3490
1.12	1.20	679	-115	14.2	3.57	3.00	49.2	2450
0.55	1.00	275	-350	12.3	3.52	3.00	25.6	1410

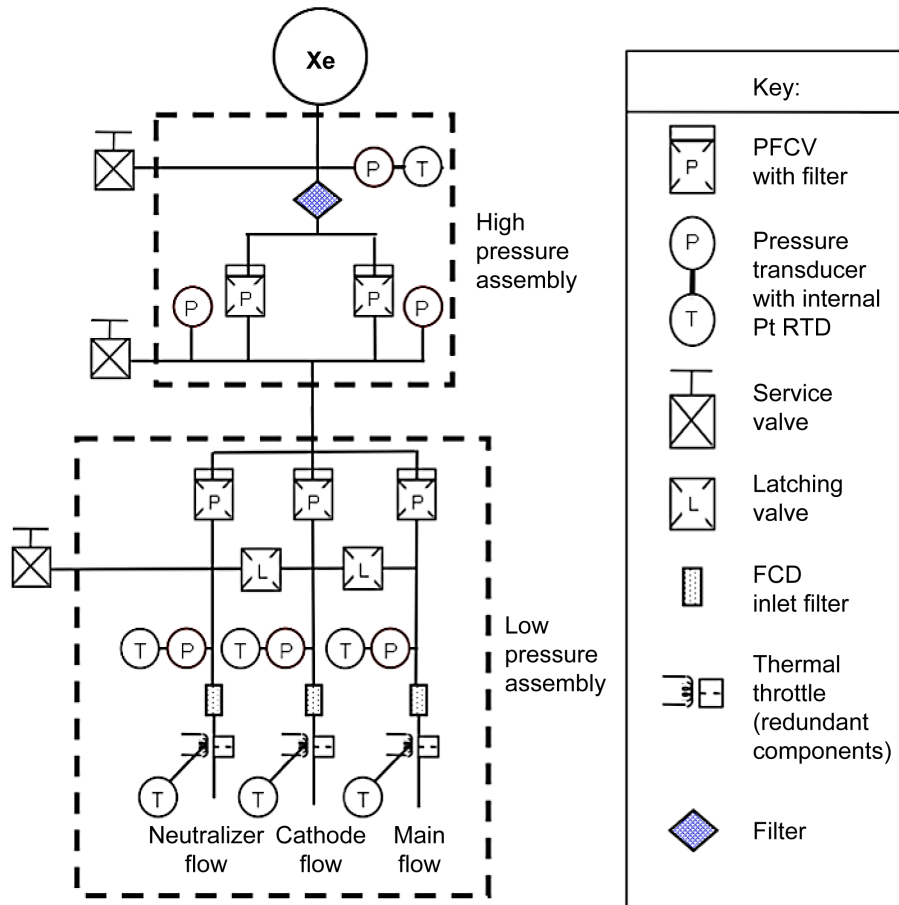

Figure 2.—Schematic of the NEXT PMS single string. The xenon tank is not included in the NEXT PMS development.

Propellant Management System

The propellant management system used for the system integration test was an engineering model system. The overall design approach was developed by a NEXT integrated product team led by the NEXT program’s industrial partner Aerojet, who designed and manufactured the engineering model hardware. A schematic of the PMS single string is shown in Figure 2. The PMS single string is composed of High Pressure Assembly (HPA) and Low Pressure Assembly (LPA). The HPA reduces xenon tank pressure up to a maximum expected operating inlet pressure of 18,600 kPa (2700 psia) to a regulated outlet pressure of 240 kPa (35 psia). The outlet pressure is regulated with a proportional flow control valve (PFCV) using

an outlet pressure transducer for feedback. The HPA includes a redundant PFCV and outlet pressure transducer for fault tolerance. A single HPA can provide flow to multiple LPAs for systems utilizing multiple thrusters.

The LPA provides independent flow control to each of the three thruster propellant inputs, labeled neutralizer, cathode, and main in Figure 2. During normal operation, each LPA branch flow rate is set by regulating the pressure to a heated porous plug, or thermal throttle, with a separate PFCV and pressure transducer. Thermal throttle temperature is controlled using a sheathed heater with a temperature sensor for feedback. As with the HPA, thermal throttle inlet pressure is regulated with a PFCV using a pressure transducer for feedback. The thermal throttle temperature is typically set to 75 °C and thermal throttle inlet pressures range from 77.9 to 189 kPa (11.3 to 27.4 psia) to achieve the commanded flow rates. To support fault tolerance in the design, the LPA design includes latch valves between the three branches of the LPA and the thermal throttle was designed for operation up to 400 °C. If a branch's PFCV were to fail closed or pressure transducer not operate, for example, the failed branch's latch valve would be opened. The working PFCV of the coupled branches would then regulate pressure to both branches to a constant level, and xenon flow rate would be varied by changing thermal throttle temperatures. The thermal throttle design also incorporated a redundant heater and temperature sensor for fault tolerance.

Photographs of the NEXT engineering model HPA and LPA are shown in Figures 3 and 4, respectively. The tested HPA's redundant PFCV and outlet pressure transducer for this work were mass model mock-ups to reduce assembly cost. The LPA main flow branch can output a xenon flow rate of up to 50 sccm, while the cathode and neutralizer branches can output up to 6 sccm each. The HPA and LPA weigh 1.9 and 3.1 kg, respectively. These masses include each assembly's mounting plate, connectors, and component heaters used for the system integration test.

The engineering model HPA and LPA have completed environmental testing at qualification levels. Vibration testing was conducted in April of 2005 and included three random vibration tests to 14.1 grms in each axis for 2 min each. Sinusoidal vibrations sweeps were conducted before and after each test to assess PMS health. Thermal vacuum testing was conducted in May of 2007 and included three full thermal cycles from 12 to 70 °C with 2 hr dwell times at each temperature, followed by two separate 24 hr dwell times at each temperature. Flow calibration checks were conducted prior to and following the vibration test and throughout the thermal vacuum test. Proof pressure tests, leakage checks, and electrical checks were conducted on the HPA and LPA prior to and following the vibration and thermal vacuum tests. PMS, HPAs, and LPAs successfully completed environmental testing, and the results of these tests can be found in References 17 and 18.

For this test with multiple ion thrusters, the PMS is comprised of one HPA and three LPAs that deliver regulated xenon flow to each of the three thrusters. Each thruster has three propellant lines: one for the discharge chamber plenum, one for the discharge cathode, and one for the neutralizer cathode. The LPA that is integrated with Thruster PM1R is constructed using flight-rated parts. To decrease development costs, the two LPAs integrated with Thrusters EM1 and EM5 were assembled using several non-flight components that are representative of flight hardware. The non-flight components included the latch valves, service valves, and pressure transducers. The PMS integration tests were conducted with the



Figure 3.—Photograph of the engineering model HPA.



Figure 4.—Photograph of the engineering model LPA.

For the PMS interface, the DCIU Simulator had to power the HPA and LPAs, as well as provide analog commands and digitize the incoming analog telemetry. As a result, the DCIU Simulator included separate HPA and LPA interfaces that:

- provided an adjustable 24 to 32 Vdc housekeeping power to operate the pressure transducers and latch valves;
- utilized industrial hardware for digital-to-analog conversion for analog commands and analog-to-digital conversion for processing analog telemetry;
- operated the PFCV driver circuits for pressure regulation using analog commands; and
- operated the thermal throttles using commercial DC power supplies and software-controlled proportional-integral-derivative loops for temperature control.

The DCIU Simulator also included an XFSE interface box that:

- operated separate pressure transducers to monitor PMS operation;
- operated separate mass flow controllers to independently monitor total PMS flow rates and to provide a separate flow path for thruster operation by actuating separate solenoid valves; and
- interfaced to a facility interlock to terminate propulsion system operation from a high facility pressure.

A brief description of the DCIU Simulator hardware can also be found in Reference 19.

Summary of Propulsion System Interfaces

A 22 to 34 Vdc low power bus is used by the DCIU for DCIU and PMS operation. Laboratory-class power consoles were used to power Thrusters PM1R, EM1, and EM5.

The DCIU Simulator provides power to the PMS to operate the pressure transducers, latch valves, PFCVs, and thermal throttle heaters. For flow control, the DCIU regulates LPA and HPA pressures with the PFCVs and regulates thermal throttle temperature with the throttle heaters to predefined values stored by the DCIU software. The DCIU Simulator receives analog telemetry from the PMS pressure transducers and thermal throttle temperature sensors, which are used to regulate pressures and thermal throttle temperatures.

The PMS delivers regulated xenon flow to each of the three thrusters. Each thruster has three propellant lines and the size of this tubing can affect the xenon flow rate via backpressure (i.e., the pressure just downstream of the LPA thermal throttles). This pressure is a function of thruster inlet pressure, flow rate, and tubing dimensions.

Test Setup

The following sections describe the test setup for the PMS multiple-string integration test. The overall test setup and vacuum facilities are described in the next section. This is followed by descriptions of the ion thruster, the PMS and XFSE test setups.

Overall Test Setup and Vacuum Facility

The integration test was conducted in two vacuum facilities. The thrusters and PMS, along with part of the XFSE, were installed in the NASA GRC's Vacuum Facility 6 (VF6), shown in Figure 6. This vacuum facility has a diameter of 7.6 m and an overall length of 22.9 m. It is cryogenically pumped with twelve internal cryogenic pumps for a total measured pumping speed of 290,000 L/s with xenon and a base pressure of about 1.3×10^{-5} Pa (1×10^{-7} torr). The facility also has a turbomolecular pump for the removal of lighter gases and a residual gas analyzer for monitoring residual gas partial pressures. Background pressures during full power thruster operation were within 3.7×10^{-4} Pa (2.8×10^{-6} torr), as measured by an internal ion gauge located 41 cm below the centerline of and 25 cm behind the PM1R thruster.

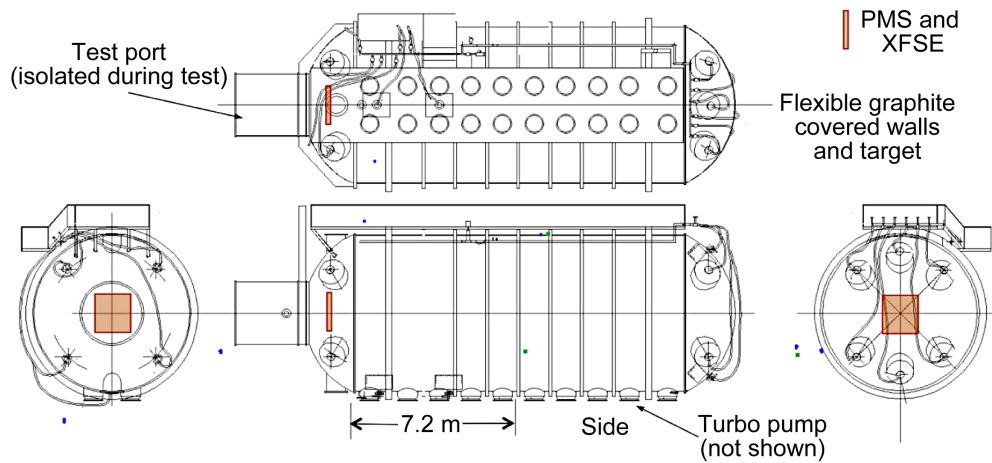

Figure 6.—Schematic of the PMS and XFSE in NASA GRC's Vacuum Facility 6.

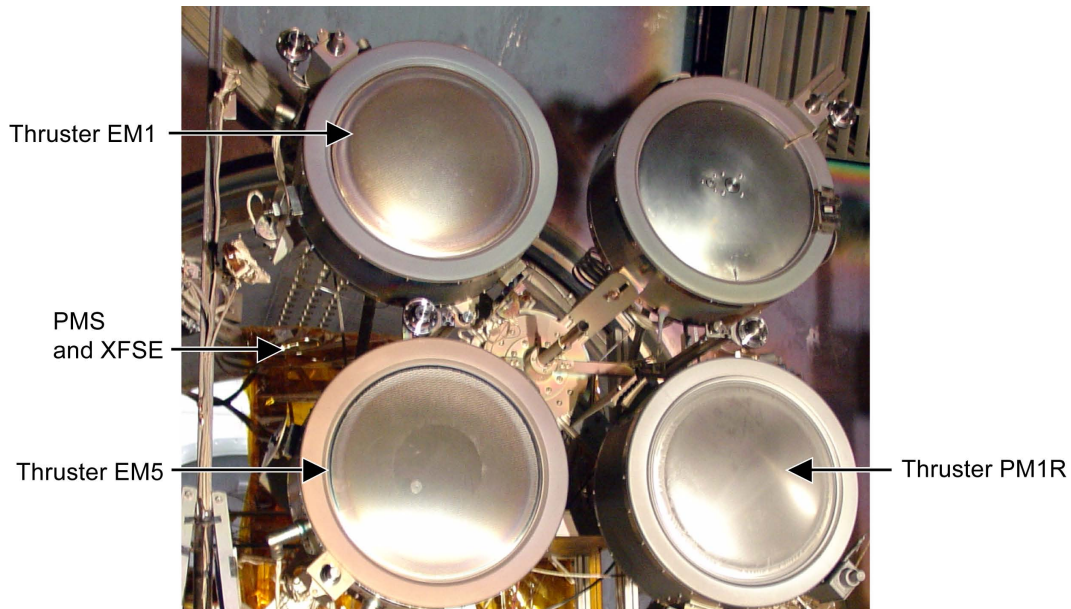

Figure 7.—Photograph of Thrusters PM1R, EM1, and EM5 mounted in NASA GRC's VF6. Thrusters EM1 and EM5 are located top-left and bottom-left in the array, respectively. The thruster located top-right is not operational and contains plasma diagnostics on a domed ion optics simulator.

Ion Thruster Setup

Thrusters PM1R, EM1, and EM5 were mounted in VF6 on the multi-thruster array test mount, as shown in Figure 7 (Ref. 7). The setup was nearly identical to that used for the NEXT Single String Integration Test (SSIT) (Ref. 14). The PMS and XFSE were mounted behind the thrusters, as shown in Figure 7. Thrusters were operated with the PMS in one-string, two-string, and three-string configurations. Thrusters and specific throttle points selected are shown in Table 3. Thrusters were operated in four sequences, namely: (1) Thruster PM1R at full power, (2) Thruster PM1R at full power with Thruster EM5 at low throttle conditions, (3) Thruster PM1R at full power with Thruster EM1 operated over the entire throttle range, and (4) Thrusters PM1R and EM1 at full power with Thruster EM5 operated over the entire throttle range.

TABLE 3.—THRUSTERS AND THROTTLE POINTS USED TO DEMONSTRATE PMS PERFORMANCE

Data set	Throttle point for thruster PM1R		Throttle point for thruster EM1		Throttle point for thruster EM5	
	Beam current, A	Beam voltage, V	Beam current, A	Beam voltage, V	Beam current, A	Beam voltage, V
1	3.54	1800	-----	-----	-----	-----
2	3.54	1800	-----	-----	1.01	275
3	3.54	1800	-----	-----	1.20	679
4	3.54	1800	-----	-----	2.00	1180
5	3.54	1800	1.00	276	-----	-----
6	3.54	1800	1.21	679	-----	-----
7	3.54	1800	2.01	1179	-----	-----
8	3.54	1800	2.71	1179	-----	-----
9	3.54	1800	3.54	1800	-----	-----
10	3.54	1800	3.54	1800	1.01	275
11	3.54	1800	3.54	1800	1.21	679
12	3.54	1800	3.54	1800	2.02	1179
13	3.54	1800	3.54	1800	2.72	1179
14	3.54	1800	3.54	1800	3.54	1179
15	3.54	1800	3.54	1800	3.55	1800
16	3.54	1800	3.54	1800	3.56	1800
17	3.54	1800	3.54	1800	3.55	1800

Power Consoles

Thrusters PM1R, EM1, and EM5 were operated with power consoles similar to that described in Reference 10. These power consoles utilized six commercially available power supplies to operate the main discharge, discharge cathode heater, neutralizer keeper discharge, and neutralizer heater. The consoles also provided constant voltages for the accelerator grid and for beam ion acceleration. Although the NEXT peak input power is about 7 kW with a maximum power supply voltage of 1800 V, these consoles can provide ion thruster input powers in excess of 10 kW with beam power supply voltages up to 2000 V.

Propellant Management System and XFSE Setup

The PMS was integrated into a XFSE assembly, as shown on the schematic in Figure 8. The XFSE is ground test-support equipment and, therefore, not a part of the flight system but was still controlled by the DCIU Simulator. The XFSE was used to monitor the operation of the PMS during the integration test and to provide a secondary thruster gas feed system. The XFSE was divided into two systems. The external XFSE was located on atmospheric side of VF6. It included mass flow controllers for checking LPA flow rate calibrations and could independently provide flow to the thruster using mass flow controllers, thus allowing for thruster operation using a standard flow regulation configuration. The internal XFSE was located within VF6. It included manual and solenoid valves that allowed for configuration changes, such as thruster operation with and without the PMS. The internal XFSE included one HPA and three LPAs for multi-thruster PMS operation. The internal XFSE and PMS were covered with a polyimide foil for protection against back-sputtered material deposition.

Tubing and components of the PMS and XFSE were wrapped with heater tape for a bake-out to remove air and adsorbed moisture on surfaces exposed to atmosphere. About twenty thermocouples were mounted on key PMS and XFSE components and were monitored and recorded by the DCIU Simulator throughout testing. To simulate pressure drops due to viscosity, the tubing leading from the LPA outlet to the thruster inlet included 3.5 m of 0.32 cm diameter × 0.71 mm wall tubing, which is similar to the longest tubing length used with the Dawn (Ref. 4) ion thruster propellant management system.

For this integration test, the DCIU Simulator monitored and recorded all pressures, temperatures, and flows measured by the PMS and XFSE at a rate of 1 Hz. The DCIU Simulator also monitored and recorded PMS component input currents and voltages other than those of the pressure transducers, which were manually recorded. For the PMS, the DCIU Simulator regulated HPA outlet pressure, LPA outlet flow rates, and thermal throttle temperatures, and controlled latch valve position and the selection of primary or redundant thermal throttle heaters. For the XFSE, the DCIU Simulator controlled and recorded telemetry from the mass flow controllers.

Test Results and Discussion

This section will present the test results of the PMS integration test with multiple thrusters. PMS flow rate calibration checks and integration of the PMS were performed with NEXT Thrusters PM1R, EM1, and EM5. The PMS-multi-thruster integration test demonstrated that the PMS could successfully interface with and operate NEXT ion thrusters with no anomalous thruster or PMS behavior. Thrusters and throttle points used to demonstrate PMS performance are shown in Table 3.

Flow Rate Calibration Checks With Single and Multiple Thrusters

Calibration checks were conducted with the PMS under vacuum and while connected to various combinations of operational Thrusters PM1R, EM1, and EM5. Figure 8 shows the flow path and valve positions. Calibration checks were performed on LPA branches for single or 2-thruster operation. Total LPA flow rates were compared with the calibrated flow rate from the XFSE mass flow controllers. A maximum of two thrusters were used in this checkout procedure because the XFSE mass flow controllers had a maximum flow rate of only 75, 10, and 10 sccm for the main, cathode, and neutralizer branches, respectively. The XFSE flow controller valves were fully opened so it would measure and not regulate the flow rate. To reduce mass flow controller measurement error, flow rate calibration checks were made in 5 s intervals for 5 min and averaged to determine the actual flow rate. Further, sufficient time was allowed between mass flow rate changes for the pressure downstream of the XFSE metering to reach equilibrium.

The XFSE mass flow controller accuracy had to be considered when assessing LPA flow rate error. The main mass flow controller accuracy was ± 1 percent of the indicated reading for flow rates from 26 to 75 sccm. Both XFSE cathode and neutralizer flow controller accuracies were ± 1 percent for flow rates from 3.5 to 10 sccm. For all the flow rates presented herein, the accuracy of all XFSE mass flow controllers was ± 1 percent. LPA indicated flow rates were simply compared to the calibrated XFSE mass flow rates. The results of the calibration checks are shown in Table 4. First, Thruster PM1R was operated at full power with the PMS, and the total LPA flow rate was within 0.4 percent of the calibrated total flow rates of the XFSE mass flow controllers. Next, Thruster PM1R was operated at full power of 6.86 kW, and Thruster EM5 was operated at three power levels from 0.55 to 2.78 kW. In these three cases the total LPA flow rate differed from the XFSE calibrated total flow rate by 1.0 to 1.3 percent. Finally, Thruster PM1R was run at full power while Thruster EM1 was throttled from 0.55 to 2.78 kW. Again the LPA total flow rate differed from the XFSE total flow rate by 1.1 to 1.3 percent. Overall, the data of Table 4 indicate that the total LPA flow rates compare very favorably, within 1.4 percent, to the calibrated XFSE flow rates.

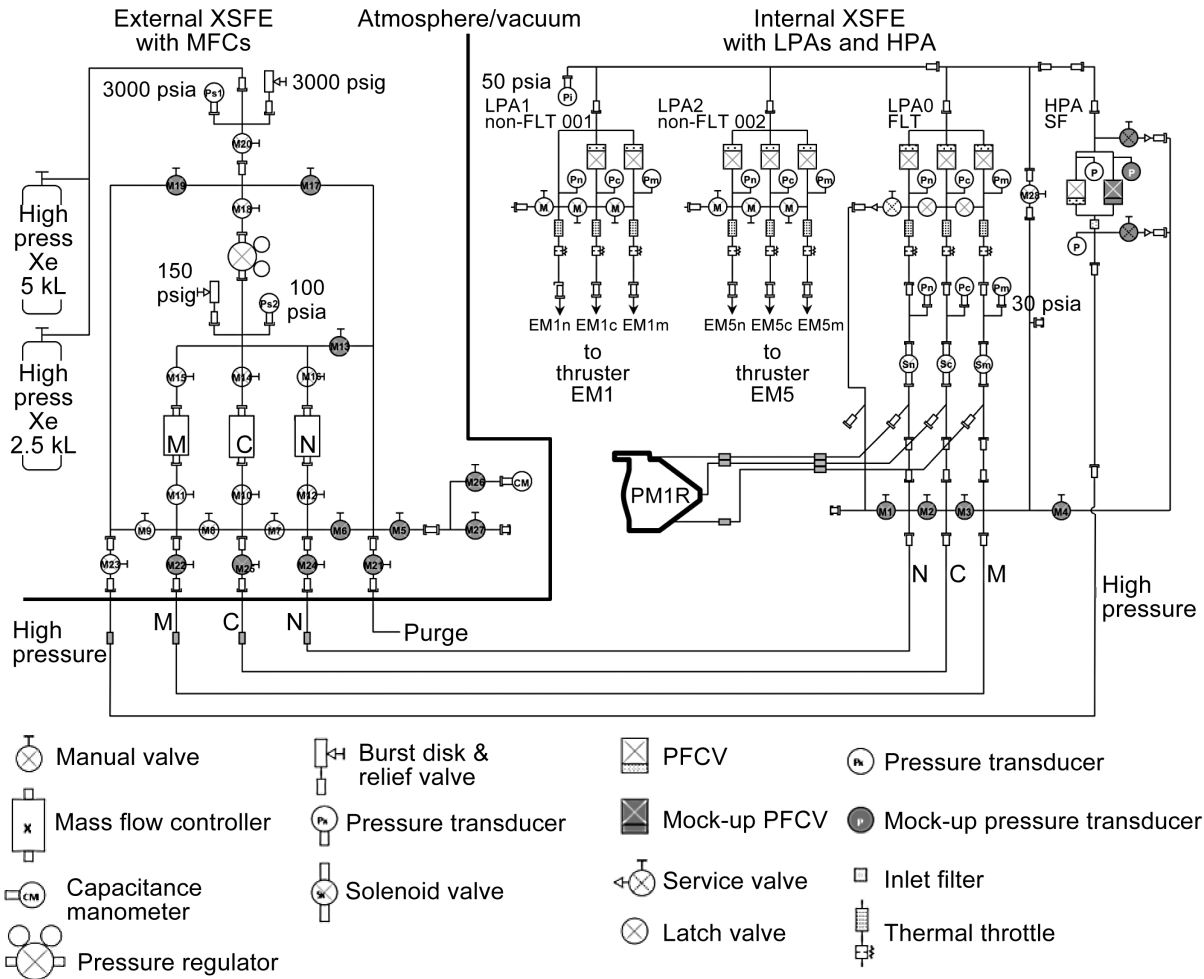

Figure 8.—Schematic of the PMS and the Xenon Feed Support Equipment for the 3-string PMS integration test with Thrusters PM1R, EM1, and EM5. A shaded valve indicates it is closed. A white valve indicates it is open. Here, “M”, “C”, and “N” are the main, cathode, and neutralizer flow branches, respectively. “HP” is the high pressure outlet of the internal XFSE that leads to the HPA inlet. This setup was used for calibration checks with one or two thrusters as well as for extended operation with one, two, or three thrusters.

TABLE 4.—PMS FLOW RATE CALIBRATION CHECKS DURING SINGLE AND MULTIPLE THRUSTER OPERATION

Data set	First thruster—LPA indicated flow rate			Second thruster—LPA indicated flow rate			Total LPA indicated flow rate, sccm	Total MFC flow rate, sccm	Overall LPA error, percent
	Main flow rate, sccm	Cathode flow rate, sccm	Neut. flow rate, sccm	Main flow rate, sccm	Cathode flow rate, sccm	Neut. flow rate, sccm			
Thruster PM1R									
1	49.7	4.87	4.01	----	----	----	58.6	58.8	0.4
Thruster PM1R Thruster EM5									
2	49.7	4.87	4.01	12.4	3.53	3.00	77.5	76.5	-1.3
3	49.7	4.87	4.02	14.3	3.58	3.01	79.5	78.6	-1.0
4	49.7	4.87	4.02	25.9	3.88	2.51	90.9	90.0	-1.0
Thruster PM1R Thruster EM1									
5	49.6	4.87	4.01	12.4	3.52	3.01	77.4	76.5	-1.2
6	49.7	4.87	4.01	14.3	3.57	3.01	79.5	78.5	-1.1
7	49.7	4.87	4.02	25.8	3.87	2.51	90.8	89.6	-1.3

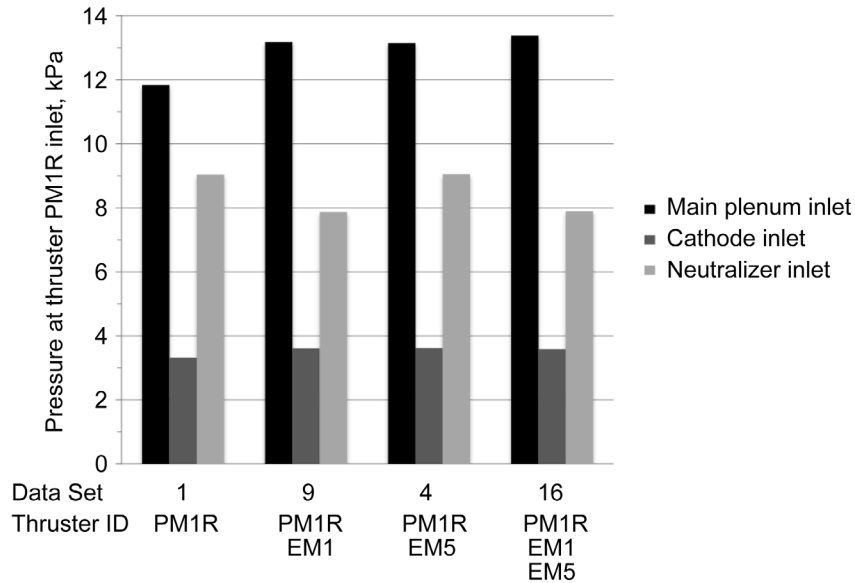

Figure 9.—Thruster PM1R inlet pressures for 1-thruster, 2-thruster, and 3-thruster configurations used with the multi-leg PMS. All thermal throttle temperatures were 75 °C.

Thruster PM1R Inlet Pressure

The repeatability of PMS performance can be examined by measuring the thruster inlet pressures to the main plenum, the discharge cathode, and the neutralizer. These pressure measurements were made at the inlet to Thruster PM1R as it performed 1-thruster, 2-thruster, and 3-thruster operation with the PMS. Pressure transducer error bands were less than ± 0.3 percent of the full-scale pressure. The inlet pressure data are shown in Figure 9. For 2-thruster and 3-thruster operation, the main plenum and cathode inlet pressures are within 1.7 and 1.1 percent of each other, respectively. The main plenum pressure at full power is about 13.4 kPa or 100 torr. The neutralizer inlet pressure did vary by as much as 13 percent. This result may indicate that the neutralizer cathode assembly had not yet reached thermal equilibrium. Data Set 1 provides inlet pressures for Thruster PM1R for single thruster operation. The main inlet pressure in this case is lower than all other cases, and this effect can be attributed to lack of thermal equilibrium since data were taken more rapidly in this situation. The main plenum inlet pressure data from Data Sets 4, 9, and 16 are nearly the same as Thruster PM1R data taken during the Single String Integration Test (Ref. 14). The fact that the inlet pressure data for 2-thruster and 3-thruster operation as well as SSIT 1-thruster operation compare very favorably indicates that the flow rates to Thruster PM1R were similar in all cases.

Figure 10 shows the temporal variation of the three inlet pressures to Thruster PM1R for operation of three thrusters at full power, 6.8 kW. LPA inlet pressures, as well as the HPA outlet pressures, were very steady indicating stable flow delivery with three thrusters operating at full power.

The pressures of all LPA branches were examined every 5 s. Indicated changes in the LPA branch pressures were less than 0.1 percent when thrusters were added to the PMS, when cathodes were ignited, and when ion extraction voltages were applied. The change in HPA outlet pressure was also less than 0.1 percent when cathodes were ignited or high voltages were applied to the grids of the thrusters that were operated in single-, two-, or three-string configurations. However, changes in the HPA outlet pressure were noted when a thruster was added to the PMS and flow through the LPAs was initiated. HPA outlet pressure decreased by 12.6 percent when thruster EM1 cold flow was added to the PMS that was providing xenon to Thruster PM1R. When Thruster EM5 cold flow was added to the two-string system of Thrusters PM1R and EM1, the HPA inlet pressure decreased by 8.9 percent. In all cases the

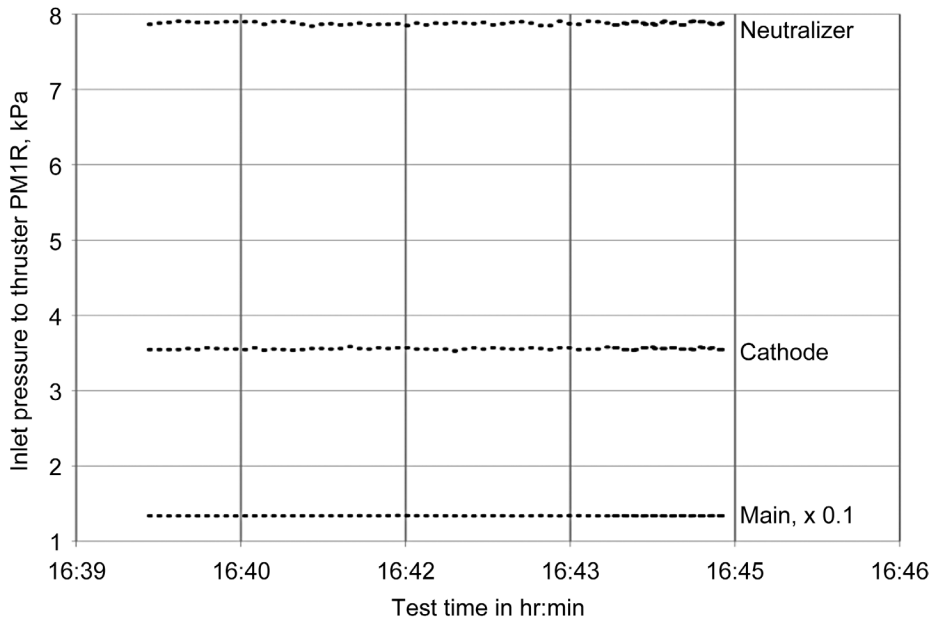

Figure 10.—Temporal variation of inlet pressures to Thruster PM1R’s main, cathode, and neutralizer ports. The PMS provided xenon to Thrusters PM1R, EM1, and EM5. All thrusters operated at 6.8 kW.

HPA outlet pressure recovered within 30 s. The change in HPA outlet pressures and pressure recovery times are dependent on the volume between the HPA and LPA branches. Although this effect did not change LPA branch pressures, it may have to be examined in subsequent flight-like feed systems that will have much smaller volumes between the HPA and LPA branches.

Thruster Performance Data

The PMS demonstration test with single and multiple thrusters included examining any changes in thruster performance as more operating thrusters were added to the PMS. Performance characterizations included discharge losses, accelerator grid current, and neutralizer performance.

Discharge Chamber Performance

Figure 11 shows the thruster discharge voltage for 1-thruster, 2-thruster, and 3-thruster operation with the PMS. All data were taken at full power of 6.8 kW. All three thrusters were operated with identical main plenum, discharge cathode, and neutralizer flow rates. Given the fixed flow rates, the discharge voltage for Thrusters PM1R, EM1, and EM5 varied by less than 0.40, 0.43, and 0.50 V, respectively, as single or multiple thrusters were tested with the PMS. These data are consistent with the SSIT data and the results of two performance acceptance tests of Thruster PM1R (Ref. 14). The very small changes in discharge voltage for single or multiple thruster testing is a good signature of steady and repeatable flow rates provided by the PMS.

Figure 12 displays the variation in discharge losses at full power as one, two, or three thrusters are operated with the PMS. During the course of single or multiple thruster testing with the PMS, the discharge losses, for a given thruster, vary by less than 4 W per beam ampere. This shows that xenon flow delivery and thruster discharge chamber performance are insensitive to the number of thrusters operated with the PMS.

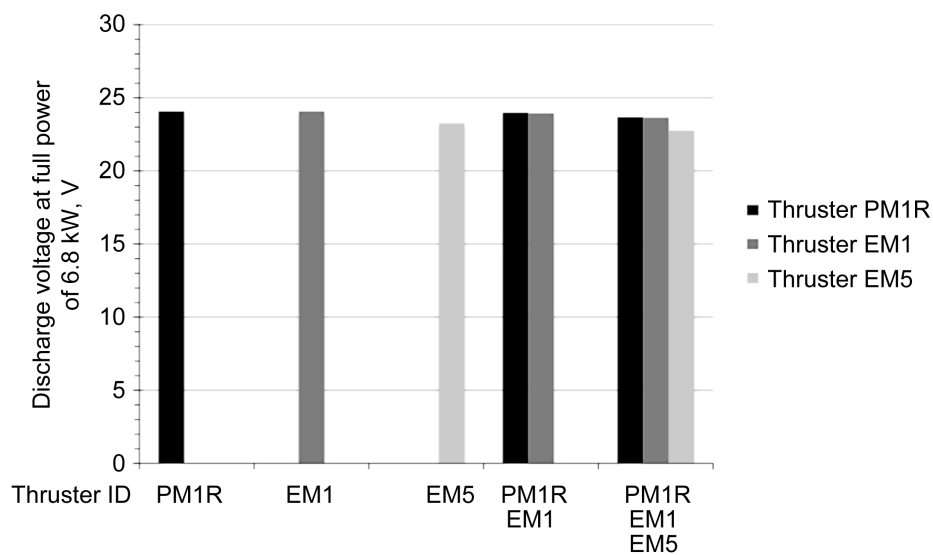

Figure 11.—Discharge voltage as one, two, or three thrusters are used with the NEXT PMS. All data at full power: 3.52 A beam current and 1800 V beam power supply voltage.

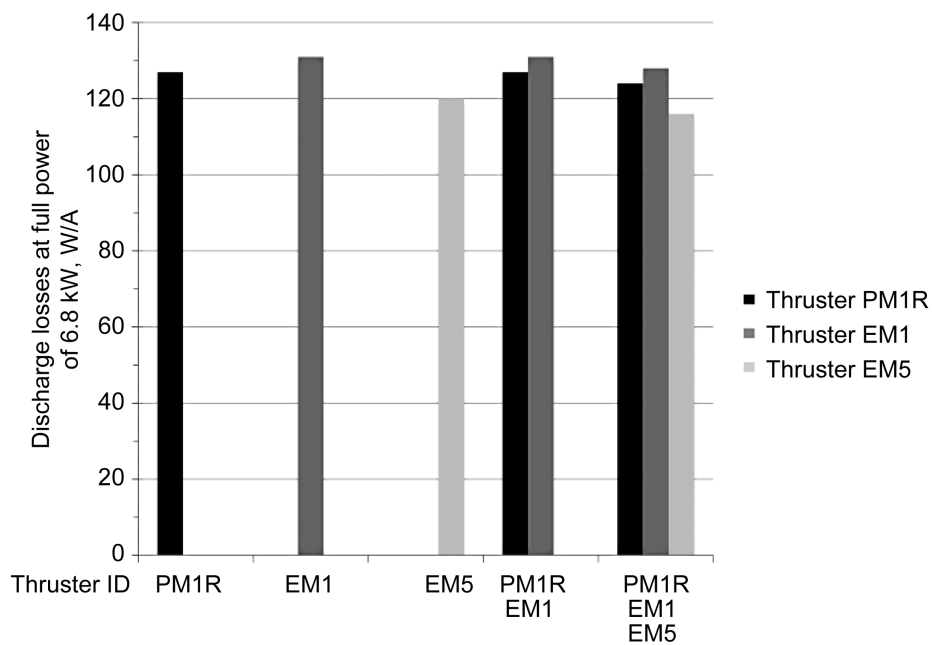

Figure 12.—Variation of thruster discharge chamber performance as one, two, or three thrusters are used with the NEXT PMS. All data at full power: 3.52 A beam current and 1800 V beam power supply voltage.

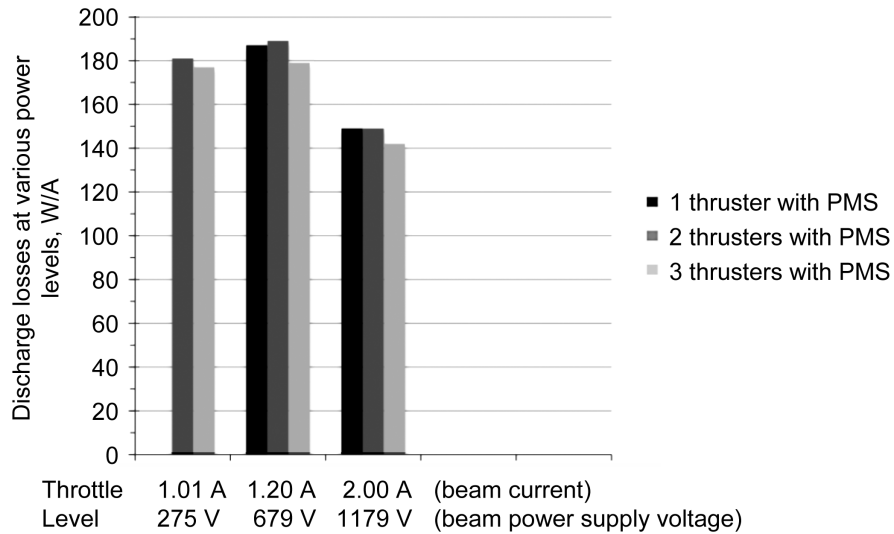

Figure 13.—Variation of the discharge chamber performance of Thruster EM5 as multiple thrusters, at various throttle levels, are used with the PMS.

The discharge losses of Thruster EM5 are shown in Figure 13 at throttle levels of 0.55, 1.12, and 2.78 kW. Thrusters PM1R and EM1 were run at highest throttle level of 6.86 kW. These data were taken for single and multiple thruster operation with the PMS. For Thruster EM5 throttle levels of 0.55, 1.12, and 2.78 kW, the variation in discharge losses was <5.3 percent for 1-thruster, 2-thruster, or 3-thruster operation with the PMS. This result is not much different from dispersions in discharge chamber performance when thrusters are operated individually. For example, the dispersion in discharge losses for Thrusters EM1, EM2, EM4, and PM1 at full power, was found to be about 7 percent (Ref. 20).

At all three throttle levels the discharge losses of Thruster EM5 were lower when three thrusters were operating. This result is likely independent of PMS operation and may be due to more efficient operation due to xenon ingestion at the higher vacuum facility pressures.

Accelerator Grid Current

Figure 14 shows displays the thruster accelerator grid current as one, two, or three thrusters were used with the NEXT PMS. All data were at the full power throttle level: 3.52 A beam current and 1800 V beam power supply voltage. Accelerator currents for Thrusters PM1R and EM1 were nearly the same for single thruster operation. During single thruster operation, the accelerator current for Thruster EM5 was 8.8 percent higher than Thruster EM1 at full power. In dispersion analyses of the EM thrusters (Ref. 20), Thruster EM5 had a much larger peak ion current density, and this might account for the difference in accelerator grid currents. Additionally, the local vacuum facility pressure in the vicinity of Thruster EM5 may be slightly higher because it is immediately adjacent to both Thrusters EM1 and PM1R.

For 2-thruster or 3-thruster operation with the PMS, the accelerator grid currents of Thrusters PM1R and EM1 were the same. Higher accelerator grid currents for multiple thruster operation are expected due to increased charge exchange ion impingement caused by higher vacuum facility pressures. The accelerator current for Thruster EM5 again is about 9 percent higher than that of Thrusters PM1R and EM1 during 3-thruster operation. For the most part the accelerator grid current values were as expected, and no anomalies were apparent due to single or multiple thruster operation with the PMS.

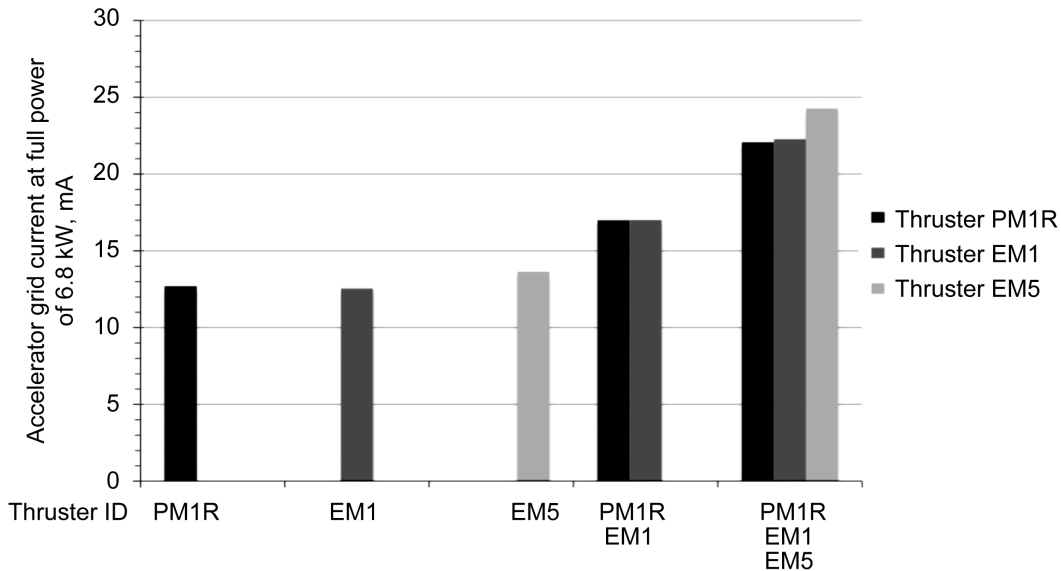

Figure 14.—Accelerator grid current as one, two, or three thrusters are used with the NEXT PMS. All data at full power: 3.52 A beam current and 1800 V beam power supply voltage.

Neutralizer Performance

The neutralizer keeper and coupling voltages for full power operation are shown in Figure 15. Neutralizer keeper and coupling voltages were within 1.0 and 1.6 V, respectively, for all three thrusters operating as single or multiple thrusters with the PMS. Dispersion data taken at full power with Thruster PM1R and Thruster EM1, operating in 1-thruster, 2-thruster, and 3-thruster configurations, indicated the neutralizer keeper and coupling voltages varied by less than 0.5 and 1.1 V, respectively. Thruster EM5, operating in 1-thruster and 3-thruster configurations, had neutralizer keeper and coupling voltage variations of only 0.37 and 0.22 V, respectively at full power. The small changes in neutralizer voltages support the fact that xenon flow rates are constant for single or multiple thruster testing with the PMS.

PMS Power Consumption

The propellant management system power consumption is tabulated in Table 5. These powers were determined from currents and voltages that were measured by the DCIU Simulator for the thermal throttles and the proportional flow control valves, and by multi-meters for the pressure transducers. In all cases the thermal throttle temperatures were set at 75 °C, and the input voltage to the DCIU Simulator was 28 V. The total power consumed by the HPA and LPAs was 10.0, 17.9, and 25.2 W, respectively, for single, 2-thruster, and 3-thruster operation. In all cases, the HPA consumed 1.6 to 1.7 W. The thermal throttle heaters accounted for about 52 percent of the total PMS power for single or multiple thruster operations. The PMS power consumption for single thruster operation was nearly identical to results obtained during the single-string integration test of the PMS and Thruster PM1R (Ref. 14). The PMS demonstrated successful operation over a wide throttling range for single and multiple thrusters.

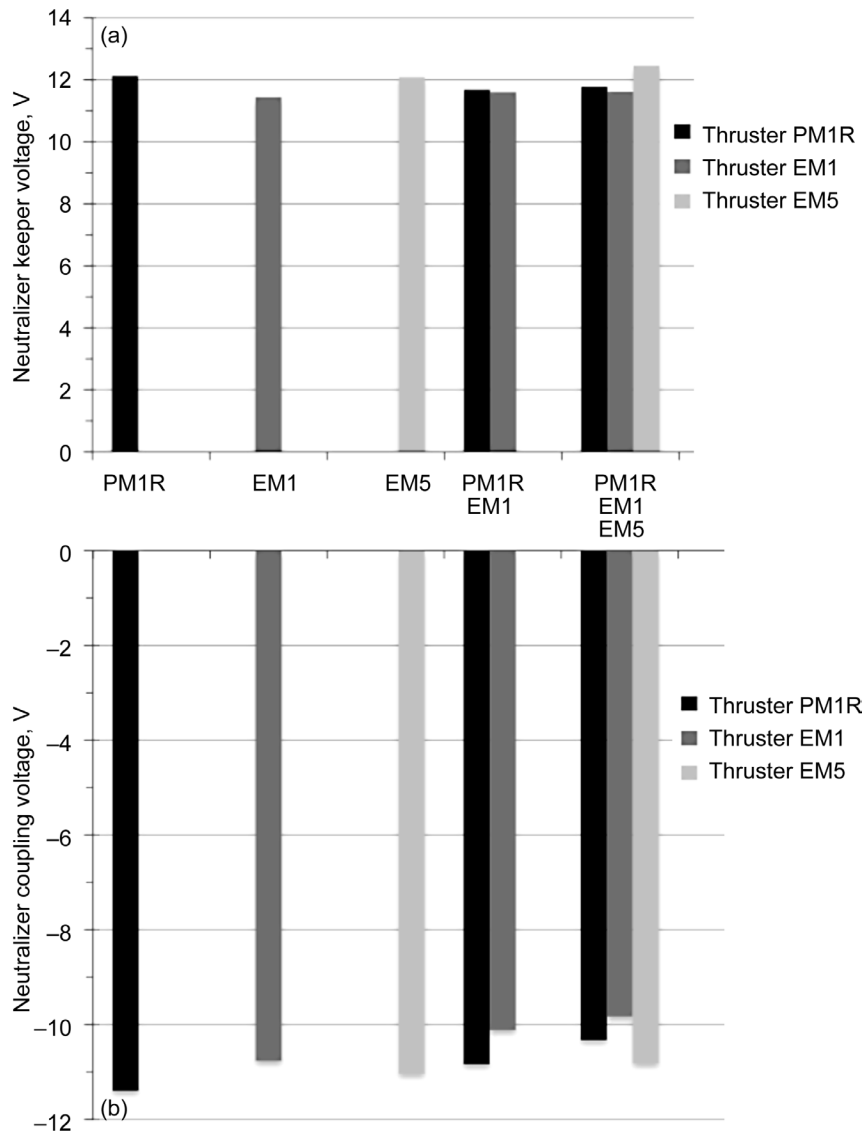

Figure 15.—Variation of neutralizer performance as single and multiple thrusters are used with the NEXT PMS. All data are for full power operation. (a) Neutralizer keeper voltage. (b) Neutralizer coupling voltage.

TABLE 5.—NOMINAL PMS POWER CONSUMPTION FOR ONE-, TWO-, AND THREE-STRING OPERATION

[Low power bus voltage: 28 V. Thermal throttle temperatures: 75 °C.]

	Thruster(s)	HPA Power, W			LPA Power, W				Power, W
		Pressure transducers	PFCV	Total	Pressure transducers ^a	PFCV	Thermal throttle	Total	
One-string	PM1R	0.96	0.64	1.60	1.42	1.78	5.20	8.40	10.0
Two-string	PM1R				1.42	1.87	4.58	7.87	
	EM1				1.42	2.19	4.77	8.38	
	PM1R + EM1	0.96	0.68	1.64	2.84	4.06	9.35	16.25	17.9
Three-string	PM1R				1.42	1.93	4.10	7.45	
	EM1				1.42	2.25	4.30	7.97	
	EM5				1.42	2.16	4.50	8.08	
	PM1R + EM1 + EM5	0.96	0.73	1.69	4.26	6.34	12.90	23.50	25.2

^aPressure transducer power levels assumed EM transducer power values since the two commercial pressure transducer's power consumption was not representative of flight-rated pressure transducers.

Propellant Management System and Propulsion System Satisfied Requirements

This sub-system integration test of the PMS, the DCIU Simulator, and multiple thrusters addressed, in part, some of the NEXT PMS and ion propulsion system performance and functionality requirements. Some of these requirements are identified here. The PMS demonstrated propellant flow control commensurate with single or multiple thruster operations over the system throttling range. The PMS design had the capability to simultaneously deliver xenon to 3 thrusters operating at full power. With all three thrusters operating, the PMS, DCIU Simulator, and thruster data demonstrated the xenon flow rates and thruster performance were consistent with project requirements. The DCIU Simulator did provide sub-system throttling capabilities with single or multiple thrusters over the throttling range. The sub-system engineering data stream, rate of data collected for storage, and collection intervals were adjustable through the DCIU Simulator. Finally, the PMS did accommodate the back-pressure at the three thruster interfaces over the throttling range.

Concluding Remarks

As a critical part of the NEXT test validation process, a multiple-string integration test was performed on the NEXT propellant management system and ion thrusters. The objectives of this test were to verify that the PMS is capable of providing stable flow control to single or multiple thrusters operating over the system throttling range and to demonstrate to potential users that the NEXT PMS is ready for transition to flight. Propulsion sub-system elements included in this integration test were: 1) an engineering model ion thruster, labeled PM1R, that has successfully completed environmental testing at qualification levels; 2) two development-type engineering model thrusters; 3) an engineering model propellant management system that has successfully completed environmental testing at qualification levels; 4) three laboratory-class power consoles; and 5) a breadboard DCIU Simulator that acted as a test console.

A test plan was developed for the sub-system integration test for verification of PMS and IPS performance and functionality requirements. Propellant management system calibrations were checked during the single and multi-thruster testing. Calibration checks were performed on total LPA branch flow rates by comparing them to XFSE mass flow controller flow rates that were previously calibrated against a standard. A maximum of two thrusters were used in this procedure because the XFSE mass flow controllers had a maximum xenon flow rate of only 75, 10, and 10 sccm for the main plenum, cathode, and neutralizer branches, respectively. Overall, the calibration check of LPA total flow rates to the thruster(s) compare very favorably, within 1.4 percent, of the calibrated XFSE flow rates. Also, the inlet pressures to the main, cathode, and neutralizer ports of Thruster PM1R were measured as the PMS operated in 1-thruster, 2-thruster, and 3-thruster configurations. Variations of the inlet pressures with time were found to be insignificant, indicating steady flow to Thruster PM1R. It was found that the inlet pressures to Thruster PM1R for 2-thruster and 3-thruster operation as well as single thruster operation with the PMS during the SSIT compare very favorably indicating that flow rates to Thruster PM1R were similar in all cases.

Characterizations of discharge losses, accelerator grid current, and neutralizer performance were performed as more operating thrusters were added to the PMS. There were very small changes in discharge voltage for single or multiple thruster testing which is a good signature of steady repeatable flow rates provided by the PMS. With thrusters operating a full power, the discharge losses, for a given thruster, varied by less than 4 W per beam ampere during the course of single or multiple thruster operations with the PMS. There were also no unexpected variations in discharge losses as thrusters were throttled and single and multiple thruster operations were conducted. The accelerator grid current values were as expected, and no anomalies were apparent due to single or multiple thruster operations with the PMS. Neutralizer keeper and coupling voltages were within 1.0 and 1.6 V, respectively, for all three thrusters operating a single or multiple thrusters with the PMS. This result confirms that flow rates to the thrusters are constant for single or multiple thruster testing.

The propellant management system power consumption was at a fixed voltage to the DCIU and a fixed thermal throttle temperature of 75 °C. The total power consumed by the HPA and the LPAs was 10.0, 17.9, and 25.2 W, respectively, for single, 2-thruster, and 3-thruster operation with the PMS.

This sub-system integration test of the PMS, the DCIU Simulator, and multiple thrusters addressed, in part, some of the PMS and IPS performance and functionality requirements. Some of the key requirements addressed were: 1) The PMS demonstrated providing propellant flow control commensurate with single or multiple thruster operations over the system throttling range; 2) With all three thrusters operating, the PMS, DCIU Simulator, and thruster data demonstrated the xenon flow rates and thruster performance were consistent with project requirements. 3) The DCIU Simulator did provide sub-system throttling capabilities with single or multiple thrusters over the throttling range; 4) The PMS did accommodate the back-pressure at the three thruster interfaces over the throttling range.

References

1. Patterson, M.J. and Benson, S.W., "NEXT Ion Propulsion System Development Status and Performance," AIAA Paper 2007-5199, July 2007.
2. Benson, S.W. and Patterson, M.J., "NEXT Ion Propulsion System Progress Towards Technology Readiness," AIAA Paper 2008-5285, July 2008.
3. Polk, J.E., Brinza, D.E., Kakuda, R.Y., Brophy, J.R., Katz, I., Anderson, J.R., Rawlin, V.K., Patterson, M.J., Sovey, J.S. and Hamley, J.A., "Demonstration of the NSTAR Ion Propulsion System on the Deep Space One Mission," IEPC Paper 01-075, October 2001.
4. Brophy, J.R., Garner, C.E., and Mikes, S.C., "Development Dawn Ion Propulsion System – Initial Checkout after Launch," AIAA Paper 2008-4917, July 2006.
5. Hoskins, W.A., Wilson, F.C., Polaha, J., Talerico, L.A., Patterson, M.J., Soulas, G.C. and Sovey, J.S., "Development of a Prototype Model Ion Thruster for the NEXT System," AIAA Paper 2004-4111, July 2004.
6. Snyder, J.S., Anderson, J.R., Van Noord, J.L. and Soulas, G.C., "Environmental Testing of the NEXT PM1R Ion Engine," IEPC Paper 2007-276, September 2007.
7. Patterson, M.J., Foster, J., McEwen, H., Pencil, E., Van Noord, J.L. and Herman, D.A., "NEXT Multi-Thruster Array Test – Engineering Demonstration," AIAA Paper 2006-5180, July 2006.
8. Aadland, R.S., Frederick, J., Benson, S.W. and Malone, S.P., "Development Results of the NEXT Propellant Management System," JANNAF Proceedings, December 2005.
9. Hoskins, W.A., Wilson, F.C., Aadland, R.S., Monheiser, J., Talerico, L.A. and Polaha, J., "Overview of the NEXT Ion Propulsion System Program at Aerojet," AIAA Paper 2005-3885, July 2005.
10. Pinero, L.R., Patterson, M.J., and Satterwhite, V.E., "Power Console Development for NASA's Electric Propulsion Outreach Program," IEPC Paper 93-250, September 1993.
11. Soulas, G.C., Domonkos, M.T., and Patterson, M.J., "Performance Evaluation of the NEXT Ion Engine," AIAA Paper 5278, July 2003.
12. Herman, D.A., Soulas, G.C., and Patterson, M.J., "Performance Evaluation of the Prototype-model NEXT Ion Thruster," AIAA Paper 2007-5212, July 2007.
13. Snyder, J.S., Anderson, J.R., Van Noord, J.L. and Soulas, G.C., "Environmental Testing of the NEXT PM1 Ion Engine," AIAA Paper 2007-5275, July 2007.
14. Soulas, G.C., Patterson, M.J., Pinero, L.R., Herman, D.A., and Snyder, J.S., "NEXT Single String Integration Test Results," AIAA Paper 2009-4816, July 2009.
15. Soulas, G.C., Kamhawi, H., Patterson, M.J., Britton, M.A., and Frandina, M.M., "NEXT Ion Engine 2000 Hour Wear Test Results," AIAA Paper 2004-3791, July 2004.
16. Patterson, M.J., Verhey, T.R., Soulas, G.C., and Zakany, J.S., "Space Station Cathode Design, Performance, and Operating Specifications," IEPC Paper 97-170, August 1997.
17. Aadland, R.S., Monheiser, J.M., Driscoll, E.A., Wilson, F.C. and Benson, S.W., "Development Status of the NEXT Propellant Management System," AIAA Paper 2004-3974, July 2004.

18. Aadland, R.S. and Talerico, L.A., "NEXT Propellant Management System (PMS) Thermal Vacuum Cycle Test Report," Aerojet Internal Report 2007-R-2948, Aug. 14, 2007.
19. Hoskins, W.A., Aadland, R.S., Meckel, N.J., Talerico, L.A., and Monheiser, J.M., "NEXT Ion Propulsion System Production Readiness," AIAA Paper 2007-5856, July 2007.
20. Soulas, G.C. and Patterson, M.J., "NEXT Ion Thruster Performance Dispersion Analyses," AIAA Paper 2007-5213, July 2007.

REPORT DOCUMENTATION PAGE			Form Approved OMB No. 0704-0188		
<p>The public reporting burden for this collection of information is estimated to average 1 hour per response, including the time for reviewing instructions, searching existing data sources, gathering and maintaining the data needed, and completing and reviewing the collection of information. Send comments regarding this burden estimate or any other aspect of this collection of information, including suggestions for reducing this burden, to Department of Defense, Washington Headquarters Services, Directorate for Information Operations and Reports (0704-0188), 1215 Jefferson Davis Highway, Suite 1204, Arlington, VA 22202-4302. Respondents should be aware that notwithstanding any other provision of law, no person shall be subject to any penalty for failing to comply with a collection of information if it does not display a currently valid OMB control number.</p> <p>PLEASE DO NOT RETURN YOUR FORM TO THE ABOVE ADDRESS.</p>					
1. REPORT DATE (DD-MM-YYYY) 01-05-2011		2. REPORT TYPE Technical Memorandum		3. DATES COVERED (From - To)	
4. TITLE AND SUBTITLE NEXT Propellant Management System Integration With Multiple Ion Thrusters			5a. CONTRACT NUMBER		
			5b. GRANT NUMBER		
			5c. PROGRAM ELEMENT NUMBER		
6. AUTHOR(S) Sovey, James, S.; Soulas, George, C.; Herman, Daniel, A.			5d. PROJECT NUMBER		
			5e. TASK NUMBER		
			5f. WORK UNIT NUMBER WBS 346.620.04.05.03.13		
7. PERFORMING ORGANIZATION NAME(S) AND ADDRESS(ES) National Aeronautics and Space Administration John H. Glenn Research Center at Lewis Field Cleveland, Ohio 44135-3191			8. PERFORMING ORGANIZATION REPORT NUMBER E-17746		
9. SPONSORING/MONITORING AGENCY NAME(S) AND ADDRESS(ES) National Aeronautics and Space Administration Washington, DC 20546-0001			10. SPONSORING/MONITOR'S ACRONYM(S) NASA		
			11. SPONSORING/MONITORING REPORT NUMBER NASA/TM-2011-217040		
12. DISTRIBUTION/AVAILABILITY STATEMENT Unclassified-Unlimited Subject Categories: 20 and 23 Available electronically at http://www.sti.nasa.gov This publication is available from the NASA Center for AeroSpace Information, 443-757-5802					
13. SUPPLEMENTARY NOTES					
14. ABSTRACT As a critical part of the NEXT test validation process, a multiple-string integration test was performed on the NEXT propellant management system and ion thrusters. The objectives of this test were to verify that the PMS is capable of providing stable flow control to multiple thrusters operating over the NEXT system throttling range and to demonstrate to potential users that the NEXT PMS is ready for transition to flight. A test plan was developed for the sub-system integration test for verification of PMS and thruster system performance and functionality requirements. Propellant management system calibrations were checked during the single and multi-thruster testing. The low pressure assembly total flow rates to the thruster(s) were within 1.4 percent of the calibrated support equipment flow rates. The inlet pressures to the main, cathode, and neutralizer ports of Thruster PM1R were measured as the PMS operated in 1-thruster, 2-thruster, and 3-thruster configurations. It was found that the inlet pressures to Thruster PM1R for 2-thruster and 3-thruster operation as well as single thruster operation with the PMS compare very favorably indicating that flow rates to Thruster PM1R were similar in all cases. Characterizations of discharge losses, accelerator grid current, and neutralizer performance were performed as more operating thrusters were added to the PMS. There were no variations in these parameters as thrusters were throttled and single and multiple thruster operations were conducted. The propellant management system power consumption was at a fixed voltage to the DCIU and a fixed thermal throttle temperature of 75 °C. The total power consumed by the PMS was 10.0, 17.9, and 25.2 W, respectively, for single, 2-thruster, and 3-thruster operation with the PMS. These sub-system integration tests of the PMS, the DCIU Simulator, and multiple thrusters addressed, in part, the NEXT PMS and propulsion system performance and functionality requirements.					
15. SUBJECT TERMS Ion thruster; Ion engine; Xenon propellant; Xenon feed system; Xenon; Ion propulsion system; Propellant management system					
16. SECURITY CLASSIFICATION OF:			17. LIMITATION OF ABSTRACT	18. NUMBER OF PAGES 26	19a. NAME OF RESPONSIBLE PERSON STI Help Desk (email:help@sti.nasa.gov)
a. REPORT U	b. ABSTRACT U	c. THIS PAGE U			19b. TELEPHONE NUMBER (include area code) 443-757-5802

