

NASA/CR—2011–216468

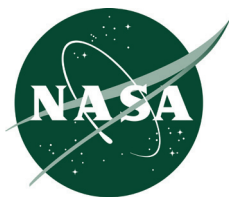

Lessons Learned in Engineering

*J.C. Blair, R.S. Ryan, and L.A. Schutzenhofer
AI Signal Research, Inc., Huntsville, Alabama*

Prepared for Marshall Space Flight Center
under Contract NNM07AA77C

June 2011

The NASA STI Program...in Profile

Since its founding, NASA has been dedicated to the advancement of aeronautics and space science. The NASA Scientific and Technical Information (STI) Program Office plays a key part in helping NASA maintain this important role.

The NASA STI Program Office is operated by Langley Research Center, the lead center for NASA's scientific and technical information. The NASA STI Program Office provides access to the NASA STI Database, the largest collection of aeronautical and space science STI in the world. The Program Office is also NASA's institutional mechanism for disseminating the results of its research and development activities. These results are published by NASA in the NASA STI Report Series, which includes the following report types:

- **TECHNICAL PUBLICATION.** Reports of completed research or a major significant phase of research that present the results of NASA programs and include extensive data or theoretical analysis. Includes compilations of significant scientific and technical data and information deemed to be of continuing reference value. NASA's counterpart of peer-reviewed formal professional papers but has less stringent limitations on manuscript length and extent of graphic presentations.
- **TECHNICAL MEMORANDUM.** Scientific and technical findings that are preliminary or of specialized interest, e.g., quick release reports, working papers, and bibliographies that contain minimal annotation. Does not contain extensive analysis.
- **CONTRACTOR REPORT.** Scientific and technical findings by NASA-sponsored contractors and grantees.
- **CONFERENCE PUBLICATION.** Collected papers from scientific and technical conferences, symposia, seminars, or other meetings sponsored or cosponsored by NASA.
- **SPECIAL PUBLICATION.** Scientific, technical, or historical information from NASA programs, projects, and mission, often concerned with subjects having substantial public interest.
- **TECHNICAL TRANSLATION.** English-language translations of foreign scientific and technical material pertinent to NASA's mission.

Specialized services that complement the STI Program Office's diverse offerings include creating custom thesauri, building customized databases, organizing and publishing research results...even providing videos.

For more information about the NASA STI Program Office, see the following:

- Access the NASA STI program home page at <<http://www.sti.nasa.gov>>
- E-mail your question via the Internet to <help@sti.nasa.gov>
- Fax your question to the NASA STI Help Desk at 443-757-5803
- Phone the NASA STI Help Desk at 443-757-5802
- Write to:
NASA STI Help Desk
NASA Center for AeroSpace Information
7115 Standard Drive
Hanover, MD 21076-1320

NASA/CR—2011–216468

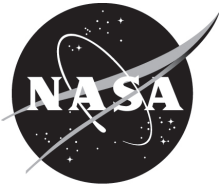

Lessons Learned in Engineering

*J.C. Blair, R.S. Ryan, and L.A. Schutzenhofer
AI Signal Research, Inc., Huntsville, Alabama*

Prepared for Marshall Space Flight Center
under Contract NNM07AA77C

National Aeronautics and
Space Administration

Marshall Space Flight Center • MSFC, Alabama 35812

June 2011

Available from:

NASA Center for AeroSpace Information
7115 Standard Drive
Hanover, MD 21076-1320
443-757-5802

This report is also available in electronic form at
<<https://www2.sti.nasa.gov>>

TABLE OF CONTENTS

| | |
|--|-----|
| INTRODUCTION | 1 |
| DISCUSSION OF LESSONS LEARNED PRINCIPLES | 9 |
| Principle I. System Success Depends on the Creativity, Judgment, and Decision- Making Skills of the People | 9 |
| Lesson 1. People are Prime Resource for Project Success | 9 |
| Lesson 2. People Skills are Mandatory for Achieving Successful Products | 20 |
| Principle II. Space Systems are Challenging, High Performance Systems | 34 |
| Lesson 3. Demand for High Performance Leads to High Power Densities and High Sensitivities | 34 |
| Principle III. Everything Acts as a System (Whole) | 38 |
| Lesson 4. Systems Engineering and Technical Integration is the Linchpin of Project Success | 39 |
| Lesson 5. Risk Management | 55 |
| Lesson 6. All Design is a Paradox, a Balancing Act | 63 |
| Principle IV. The System is Governed by the Laws of Physics | 74 |
| Lesson 7. Physics of the Problems Reigns Supreme | 74 |
| Lesson 8. Engineering is a Logical Thought Process | 87 |
| Lesson 9. Mathematics is the Same! | 89 |
| Lesson 10. Fundamentals of Launch Vehicle Design | 90 |
| Principle V. Robust Design is Based on Our Understanding of Sensitivities, Uncertainties, and Margins | 96 |
| Lesson 11. Robustness | 97 |
| Lesson 12. Understanding Sensitivities and Uncertainties is Mandatory | 103 |
| Lesson 13. Program Margins Must be Adequate | 118 |
| Principle VI. Project Success is Determined by Life Cycle Considerations | 120 |
| Lesson 14. The Design Space is Constrained Based on Where You are in the Life Cycle | 120 |
| Lesson 15. Concept Selection and Design Process | 125 |
| Lesson 16. Requirements Drive the Design | 133 |
| Lesson 17. Designing for the –Ilities and Cost | 152 |

TABLE OF CONTENTS (Continued)

| | |
|--|-----|
| Principle VII. Testing and Verification Have an Essential Role in Development | 160 |
| Lesson 18. Hardware and Data Have the Answers | 160 |
| Lesson 19. Can Test Now or You Will Test Later | 169 |
| Lesson 20. Independent Analysis, Test, and Design Keys to Success | 180 |
| Lesson 21. All Analyses and Tests are Limited | 188 |
| Lesson 22. Scaling is a Major Issue | 193 |
| Principle VIII. Anticipating and Surfacing Problems Must be Encouraged | 194 |
| Lesson 23. Must Hear and Understand All Technical and Programmatic Opinions | 194 |
| Lesson 24. There are No Small Changes! | 196 |
| Lesson 25. Expect the Unexpected | 203 |
| Principle IX. Leadership is the Foundation | 204 |
| Lesson 26. Integrity | 204 |
| Lesson 27. Focus Beyond Yourself | 205 |
| SUMMARY | 206 |
| REFERENCES | 209 |

(See CD inside back cover for supplemental information)

LIST OF FIGURES

| | | |
|-------|--|----|
| I-1. | Example Projects that Formed Basis of the Lessons | 2 |
| I-2. | Example Projects that Formed Basis of the Lessons –cont’d | 3 |
| I-3. | Example Projects that Formed Basis of the Lessons –cont’d | 3 |
| I-4. | Example Projects that Formed Basis of the Lessons –cont’d | 4 |
| I-5. | Lessons Learned Process | 5 |
| I-6. | A Triad of Principles and Lessons Concepts | 7 |
| 1-1. | It Only Hurts at Resonance | 11 |
| 1-2. | But It Does Get Rid of that Feedback Pot | 12 |
| 1-3. | So That Decimal Point Indeed Was A Fly Speck | 13 |
| 1-4. | Changing Requirements | 13 |
| 1-5. | What Change in What Specification? | 14 |
| 1-6. | “Beer Cans” Flown on Early Jupiters | 15 |
| 1-7. | Later Jupiter Configuration With Slosh Baffles | 15 |
| 1-8. | Synthetic and Measured Wind Profile Approach | 16 |
| 1-9. | Alternate SSME LOX Pump With Silicon Nitride Ball Bearings | 18 |
| 1-10. | Tether Deployment Scenario | 19 |
| 1-11. | Tether Skip Rope Characteristics | 19 |
| 1-12. | Tether Skip Rope Damper | 20 |
| 2-1. | Principles of Attitude | 22 |
| 2-2. | Tree of Life | 23 |
| 2-3. | Maslow’s Hierarchy | 25 |

LIST OF FIGURES (Continued)

| | | |
|-------|---|----|
| 2-4. | Must Lose to Gain | 28 |
| 2-5. | Model of Successive Refinement | 29 |
| 2-6. | Feedback and Followup | 30 |
| 2-7. | T- Model for Technical Integration | 32 |
| 2-8. | Communications in the Design Process | 33 |
| 3-1. | The Complexity of Managing High Risk Systems | 35 |
| 3-2. | Power Density Comparison of Transportation Systems Engines | 36 |
| 3-3. | Sensitivity Versus Performance Requirements | 37 |
| 3-4. | Dry Weight Versus Weight Contingency in Percent | 37 |
| 4-1. | Project Life Cycle Flow | 41 |
| 4-2. | Compartmentalization and Reintegration | 42 |
| 4-3. | Compartmentalization Elements | 43 |
| 4-4. | Typical Subsystems With Associated Design Functions | 44 |
| 4-5. | Technical Integration of System, Design, and Discipline Functions | 45 |
| 4-6. | Structures Design Function With Discipline Functions and Decision Gates | 46 |
| 4-7. | Technical Integration | 48 |
| 4-8. | Classical Systems Engineering | 49 |
| 4-9. | Safety and Mission Assurance | 50 |
| 4-10. | Technical Execution of Design | 51 |
| 4-11. | Elements of Product Success | 52 |
| 4-12. | STS-1 Space Shuttle Launch | 52 |

LIST OF FIGURES (Continued)

| | | |
|-------|---|----|
| 4-13. | STS-1 Space Shuttle Aerodynamic Anomaly | 53 |
| 4-14. | STS-1 Space Shuttle Aerodynamic Anomaly and Solution | 54 |
| 5-1. | Relationships Among Risk Categories | 56 |
| 5-2. | Risk Assessment Taxonomy | 57 |
| 5-3. | Acoustic Model Test Facility - 6.4% Shuttle Model | 59 |
| 5-4. | Effect of Water in Primary Side of SRB Hole on Positive Peak Overpressure | 59 |
| 5-5. | MLP Water Troughs (Water Bags) | 60 |
| 5-6. | Comparison of the Overpressure Wave at the Orbiter Base Heat Shield Without Suppression (STS-1) and With Suppression (STS-2) | 60 |
| 5-7. | SRB Ignition Overpressure | 61 |
| 5-8. | Saturn/Apollo – Instrument Unit | 62 |
| 5-9. | Schematic of Gyro Mounting and Local Deformation | 63 |
| 6-1. | Example of Performance Based Trade Studies | 65 |
| 6-2. | Design Process Balancing Act | 65 |
| 6-3. | Balance Performance, Trajectory, Control, Loads, Thermal | 66 |
| 6-4. | Comparison of Load Reduction Methods | 67 |
| 6-5. | Wind Biasing Options and Effects | 69 |
| 6-6. | Comparison of Wind Biasing Approaches for Saturn V and Shuttle | 70 |
| 6-7. | Significant Loading Events for SRB Water Impact | 71 |
| 6-8. | Typical Initial Water Impact Dynamic Events | 72 |
| 6-9. | Systems Reliability Versus Number of Engines | 73 |
| 7-1. | SRB Aft Skirt Failure at the Hold-down Post Weld Area | 76 |

LIST OF FIGURES (Continued)

| | | |
|-------|---|----|
| 7-2. | Stress in the SRB Aft Skirt Stress Distribution | 76 |
| 7-3. | Model Illustrating Effects of Spinning About Minimum and Maximum Axes of Moment of Inertia | 78 |
| 7.4. | Saturn Skylab Solar Array System (SAS) | 79 |
| 7-5. | Skylab Initial Thermal Shield Deployment | 80 |
| 7-6. | Final Skylab Configuration With Second Thermal Shield Deployed | 80 |
| 7-7. | Fuel Pump Turbine Blade High Cycle Fatigue | 81 |
| 7-8. | LOX Pump Turbine Blade Low Cycle Fatigue Problem | 82 |
| 7-9. | Bellows Flex Joint | 82 |
| 7-10. | Flex Joint Internal Tripod Tie | 83 |
| 7-11. | Bellows Failure and Duct Rupture | 83 |
| 7-12. | SRB Reentry Fluctuating Pressure Levels Without Nozzle Extension | 84 |
| 7-13. | STS 6 Aft Nozzle OAFPL With Nozzle Extension | 85 |
| 7-14. | Jupiter 1 Base Flow | 86 |
| 7-15. | Plume Induced Base Flow Field | 86 |
| 7-16. | Space Shuttle and Saturn Apollo Plume Flow | 87 |
| 8-1. | ISS Node Showing Berthing Ports and Gussets | 88 |
| 10-1. | Balancing the Key Elements of Launch Vehicle Design | 91 |
| 10-2. | Isp and Mass Fraction Uncertainty Sensitivities on Vehicle Gross Liftoff Weight | 93 |
| 10-3. | Launch Vehicle Dry Weight Sensitivity to Dry Weight Margin | 93 |
| 10-4. | Historical Mass Growth of Space Systems | 95 |
| 10-5. | Additional System Considerations for Launch Vehicle Design | 96 |

LIST OF FIGURES (Continued)

| | | |
|--------|--|-----|
| 11-1. | Saturn-V Composite Design Line Load | 100 |
| 11-2. | Inertial Upper Stage and Characteristics | 101 |
| 11-3. | Cross Section of IUS Second Stage Nozzle | 102 |
| 11-4. | Sketch of IUS First and Second Stage | 102 |
| 11-5. | Electrical Harness as Built and Corrected | 103 |
| 12-1. | Technical Uncertainty Leads to High Cost | 105 |
| 12-2. | Combined Effect of Low Uncertainty and Improved Process to Reduce Cost | 106 |
| 12-3. | Uncertainty in Structural Design | 107 |
| 12-4. | Saturn V Hold Down Post Soft Release Mechanism | 109 |
| 12-5. | Shuttle Liftoff Dynamics | 110 |
| 12-6. | Shuttle Liftoff Timing | 111 |
| 12-7. | Shuttle Liftoff Loads | 111 |
| 12-8. | Alternate LOX Turbopump Vibration Fix Summary | 113 |
| 12-9. | Artist's Conception of the SAFE Solar Array Experiment On Orbit | 114 |
| 12-10. | Picture of Deployed SAFE Solar Array Made From Space Shuttle | 114 |
| 12-11. | Partial Listing of Shuttle Parameter Variation Matrix | 115 |
| 12-12. | Solid Rocket Motor Gimbaling Nozzle | 117 |
| 13-1. | SSME Lox Pump Cross-Section Highlighting Bearing Location | 119 |
| 14-1. | ISS Science Rack Design | 122 |
| 14-2. | ISS Rack Functions and Configurations | 123 |
| 14-3. | Alternate High Pressure Turbopumps | 124 |

LIST OF FIGURES (Continued)

| | | |
|--------|---|-----|
| 15-1. | Quality Lever | 127 |
| 15-2. | Building Blocks for the First U.S. Satellite, First Manned Space Flight, and Saturn/Apollo | 127 |
| 15-3. | Saturn Apollo to the Moon | 128 |
| 15-4. | Apollo 11 Lunar Base | 129 |
| 15-5. | Space Shuttle Concept Evolution | 130 |
| 15-6. | Shuttle Performance Evolution | 132 |
| 16-1. | Sensitivity Versus Performance | 135 |
| 16-2. | Block II Space Shuttle Main Engine Requirements (109% Power Level) | 137 |
| 16-3. | Space Shuttle Main Engine Firing | 138 |
| 16-4. | SSME Components | 138 |
| 16-5. | Total Failures During SSME Development | 139 |
| 16-6. | Significant SSME Failures | 140 |
| 16-7. | Weld Offset Mismatch | 142 |
| 16-8. | Power Head, Main Injector, and Turbo-pump Assemblies | 143 |
| 16-9. | LOX Posts Failures (Engine E0002) | 143 |
| 16-10. | LOX Post Failure Mechanism | 144 |
| 16-11. | Engine E2004 Injector Failure | 144 |
| 16-12. | LOX Post Failure Pattern | 145 |
| 16-13. | Fuel Side of the Hot Gas Manifold | 146 |
| 16-14. | Total Pressure Variation Downstream of the Turnaround Duct 180°- Turn | 147 |
| 16-15. | Gimbal Bearing, LOX Inlet/Tee, and Splitter Vane | 148 |

LIST OF FIGURES (Continued)

| | | |
|--------|--|-----|
| 16-16. | 4000 Hz Splitter Vane Fixes | 149 |
| 16-17. | 4000 Hz Eliminated | 150 |
| 16-18. | Development Problems of the SSME Alternate High Pressure Turbopump | 151 |
| 16-19. | Impact of ISS Orbit Requirements on External Tank | 152 |
| 17-1. | Elements of Day of Launch I-Load Update (DOLILU) Process | 154 |
| 17-2. | Shuttle Day of Launch I-Load Update Data Flow and Timeline | 155 |
| 17-3. | Interacting Metrics of Design | 156 |
| 17-4. | Design Considering Total Life Cycle | 157 |
| 17-5. | Previous Design Approach | 158 |
| 17-6. | Desired Design Approach | 159 |
| 17-7. | Functional Relationships Enable Design Solutions for Multiple Concepts | 159 |
| 18-1. | STS 51-L SRM Field Joint and Gap Deflections | 162 |
| 18-2. | SRM Field Joint Flight Data – Thermal Distress Incidents vs. Temperature | 163 |
| 18-3. | STS 51-L Field Joint – O-Ring / Groove Tolerance Effects | 164 |
| 18-4. | RSRM Field Joint Redesign | 165 |
| 18-5. | Hubble Space Telescope | 165 |
| 18-6. | Geometry of Sandwich Structure of X-33 Fuel Tank | 167 |
| 18-7. | Failed X-33 Fuel Tank | 168 |
| 18-8. | Pressures in Failed X-33 Fuel Tank | 169 |
| 19-1. | Shuttle Orbiter Being Installed Into Dynamic Test Stand | 173 |
| 19-2. | Pogo Confidence Factor Increase With Tests | 174 |

LIST OF FIGURES (Continued)

| | | |
|-------|---|-----|
| 19-3. | Shuttle LOX Tank Hydroelastic Test Configuration | 175 |
| 19-4. | Shuttle LOX Tank Propellant Damping | 176 |
| 19-5. | Dynamic Testing Impacts | 179 |
| 19-6. | Space Station Module Test Setup | 180 |
| 20-1. | Turbopump Whirl | 181 |
| 20-2. | Acceleration Power Spectral Density (PSD) Isoplot | 182 |
| 20-3. | Rocketdyne LOX Turbopump | 183 |
| 20-4. | Main Oxidizer Valve | 184 |
| 20-5. | MOV Vibration Test-to-Test Response | 185 |
| 20-6. | MOV Inlet Pressure Fluctuations | 185 |
| 20-7. | Acoustical Mechanism | 186 |
| 20-8. | Effect of Fix | 187 |
| 21-1. | Space Shuttle MPS System | 189 |
| 21-2. | GH ₂ Diffuser | 190 |
| 21-3. | RMS Stress for Aluminum 6061 Before Fix | 190 |
| 21-4. | RMS Stress for Steel 21-6-9 After Fix | 191 |
| 21-5. | Examples of Computational Flow Dynamic Results | 192 |
| 24-1. | Tethered Satellite and Level Wind Mechanism | 197 |
| 24-2. | Pogo Oscillation Mechanism | 198 |
| 24-3. | Comparison of SI-C Longitudinal Dynamic Characteristics | 199 |
| 24-4. | S-IC Pogo Accumulator | 200 |

LIST OF FIGURES (Continued)

| | | |
|-------|--|-----|
| 24-5. | Pogo Occurrences on S-II Stage Burns | 201 |
| 24-6. | ET Intertank Insulation With and Without Pop-corning Fix | 202 |
| 25-1. | Woodpeckers on the ET Ogive | 203 |

LIST OF ACRONYMS, SYMBOLS, AND ABBREVIATIONS

| | |
|----------|--|
| AFSIG | Ascent Flight Integration Working Group |
| AIAA | American Institute of Aeronautics and Astronautics |
| ASME | American Society of Mechanical Engineers |
| AT | Alternate Turbopump |
| ATD | Alternate Turbopump Development |
| CAD | Computer-Aided Design |
| CAM | Computer-Aided Manufacturing |
| CD | Compact Disk |
| CDR | Critical Design Review |
| CFD | Computational Fluid Dynamics |
| cg or CG | Center of Gravity |
| CIL | Critical Items List |
| CM | Crew Module |
| CRES | Corrosion Resistant Steel |
| Cryo | Cryogenic |
| CSM | Command/Service Module |
| DAC | Design Analysis Cycle |
| DCR | Design Certification Review |
| DoD | Department of Defense |
| DOF | Degrees of Freedom |

LIST OF ACRONYMS, SYMBOLS, AND ABBREVIATIONS (Continued)

| | |
|-----------------|--|
| DOLILU | Day of Launch I-Load Update |
| DOP | Detail Operating Procedure |
| EPA | Environmental Protection Association |
| ET | External Tank |
| F-1 | Saturn First Stage Engine |
| FMEA | Failure Modes and Effects Analysis |
| g | Acceleration Due to Gravity (32 ft/sec) |
| GLOW | Gross Liftoff Weight |
| GH ₂ | Gaseous Hydrogen |
| GP-A | Gravity Probe-A (Redshift Experiment) |
| GVT | Ground Vibration Test |
| H-1 | Saturn IB First Stage Engine |
| HCF | High Cycle Fatigue |
| HEX | Heat Exchanger |
| HP | Horse Power |
| HPFTP | (SSME) High Pressure Fuel Turbopump |
| HPOTP | (SSME) High Pressure Oxidizer Turbopump |
| ICD | Interface Control Document |
| ILoads | Parameters for First Stage Trajectory Guidance |
| IQ | Intelligence Quotient |
| IRD | Interface Requirements Document |

LIST OF ACRONYMS, SYMBOLS, AND ABBREVIATIONS (Continued)

| | |
|-----------------|---|
| ISS | International Space Station |
| Isp | Specific Impulse |
| ISPR | International Standard Payload Rack |
| ISS | International Space Station |
| IU | Instrument Unit |
| IUS | Inertial Upper Stage |
| J-2 | Engine on Third Stage (SIV-B) of Saturn V |
| KSC | Kennedy Space Center |
| LAX | Los Angeles Airport |
| LCE | Loads Combination Equation |
| LCF | Low Cycle Fatigue |
| LES | Launch Escape System |
| LH ₂ | Liquid Hydrogen |
| LM | Lunar Module |
| LN ₂ | Gaseous Nitrogen |
| LOC | Loss of Crew |
| LOX | Liquid Oxygen |
| LOXAT | Liquid Oxygen Alternate Turbopump |
| LRU | Line Replaceable Unit |
| LWT | Light Weight Tank |
| Max q | Maximum Dynamic Pressure |

LIST OF ACRONYMS, SYMBOLS, AND ABBREVIATIONS (Continued)

| | |
|-------|---|
| MCC | Main Combustion Chamber |
| MF | Mass Fraction (measure of structural efficiency) |
| MIT | Massachusetts Institute of Technology |
| MLP | Mobile Launch Platform |
| MOV | Main Oxidizer Valve |
| MPS | Main Propulsion System |
| MSFC | Marshall Space Flight Center |
| MVGVT | Model Vehicle Ground Vibration Test |
| OAFPL | Over All Fluctuating Pressure Level |
| PDF | Probability Density Function |
| PDR | Preliminary Design Review |
| POGO | Thrust Structure Closed Loop Coupled Longitudinal Oscillation |
| POT | Potentiometer |
| PRA | Probabilistic Reliability Analysis |
| PRA | Probability Risk Assessment |
| PSD | Power Spectral Density |
| psf | Pounds per Square Foot |
| PWL | Power Level |
| P&W | Pratt and Whitney |
| PWR | Pratt Whitney Rocketdyne |
| q, Q | Dynamic Pressure |

LIST OF ACRONYMS, SYMBOLS, AND ABBREVIATIONS (Continued)

| | |
|------------------------|---|
| Q α , Q β | Dynamic Pressure Times Angle of Attack or Side Slip Angle |
| RCS | Reaction Control System |
| RMS | Root Mean Square |
| RP-1 | A Type of Hydrocarbon Rocket Fuel |
| RPM | Revolutions Per Minute |
| RSRM | Shuttle Redesigned Solid Rocket Motor |
| RSS | Root Sum Square |
| SAE | Society of Automotive Engineers |
| SAFE | Solar Array Flight Experiment |
| SAS | Solar Array System |
| S I | Saturn I |
| S-IC | First Stage of Saturn V |
| S-II | Second Stage of Saturn V |
| S-IVB | Third Stage of Saturn V |
| SLWT | Super Light Weight Tank |
| SM | Service Module |
| S&MA | Safety and Mission Assurance |
| SN | Stress Versus Number of Cycles |
| SOA | State of the Art |
| SRB | Solid Rocket Booster |
| SRM | Solid Rocket Motor |

LIST OF ACRONYMS, SYMBOLS, AND ABBREVIATIONS (Continued)

| | |
|------|--|
| SSME | Space Shuttle Main Engine |
| SSTO | Single Stage To Orbit |
| STS | Space Transportation System |
| TDRS | Tracking and Data Relay Satellite |
| TP | Technical Publication |
| TPS | Thermal Protection System |
| TRL | Technology Readiness Level |
| T/W | Thrust to Weight |
| VAB | Vehicle Assembly Building |
| VIPA | Vehicle Integrated Performance Analysis Team |

CONTRACTOR REPORT

LESSONS LEARNED IN ENGINEERING

INTRODUCTION

This report is a compilation of Lessons Learned in approximately 55 years of engineering experience by each, of James C. Blair, Robert S. Ryan and Luke Schutzenhofer. The lessons are the basis of a course on Lessons Learned that has been taught at the Marshall Space Flight Center. The lessons are drawn from NASA Space Projects and are characterized in terms of generic lessons learned from the project experience, which are further distilled into overarching principles that can be applied to future projects.

Included are discussions of the overarching principles followed by a listing of the lessons associated with that principle. The Lesson with sub-lessons are stated along with a listing of the project problems the lesson is drawn from, then each problem is illustrated and discussed with conclusions drawn in terms of Lessons Learned. The purpose of this report is to provide principles learned from past aerospace experience to help achieve greater success in future programs, and Identify application of these principles to space systems design. The problems experienced provide insight into the engineering process and are examples of the subtleties one experiences performing engineering design, manufacturing and operations. A CD of a class taught on this subject is included, providing the illustrations used in this report, along with other related material.

How to avoid the mistakes of the past and how to train people in the essence of engineering are mandatory questions we face in aerospace engineering. Those who forget the lessons from the past are doomed to repeat them. Dr. Wernher von Braun has said that; "Crash programs fail because they are based on the theory that with nine women pregnant you can get a baby in a month." Failure also occurs because we forget that physics rules and we try to bypass it in our designs.

NASA and DOD have a great heritage in Space Systems programs that have been very successful; however, they are pushing the limits of technology in order to defeat gravity, survive extreme environments, and meet their programmatic goals. In pushing the limits, we have to take risks, and in taking risks we naturally have problems.

The power density and the high efficiency requirements of space exploration lead to an unprecedented and challenging sensitivity of the system performance to the system parameters and their uncertainties, manufacturing practices, etc. which implies great risks and many potential problems. The experience we have had with these systems in the last six decades bears out these observations. NASA has lost astronauts three times, the first was the Apollo fire at KSC, the second was the loss of Challenger and its crew, and last the loss of Columbia and its crew. There are other failures that have led to loss of mission and many

other problems that have had major program impacts. DOD and the commercial side of space exploration have experienced problems of the same general categories discussed.

The goal of this report is to review the NASA programs, develop lessons learned, and from them derive basic principles that can be applied to future programs. While only those problems and systems worked on by the authors are included as examples, the lessons and principles are generic and can be applied in other technical and organizational arenas. The report concludes with a reiteration of the principles.

NASA Programs

We started out working with the Army Missile Command, on the Redstone and Jupiter missiles and their derivatives, which were eventually used in space exploration. The Saturn I was started as an Army project and then taken over by NASA. It was a vehicle that used current hardware and manufacturing processes in order to get an early heavy lift launch capability. The Saturn I first stage used the Jupiter manufacturing process and tank diameter for the center tank, and the Redstone tank diameter and manufacturing process for the clustered tanks. The first stage engines were H-1's produced by Rocketdyne, and the upper stage engines were RL-10's produced by Pratt & Whitney. After successfully launching the Saturn I vehicle we were transferred to the newly-formed NASA organization in 1960 and worked all the NASA programs including the potential new starts that did not materialize or were canceled before completion. Figure I-1 shows a partial list of the projects, and Figures I-1, I-2, I-3 & I-4 include pictures of some of the projects. Notice on Figure I-1 that a sketch of the Russian vehicles and the DOD vehicles are included. We had some small efforts on these systems. Bibliography provides details if the reader wants to explore further the various projects and their characteristics.

Basis of Lessons

- **54 Years Experience in Aerospace Engineering.**
- **Programs**
 - Redstone
 - Jupiter
 - Saturn I
 - Saturn IB
 - Saturn V Apollo
 - HEAO
 - Skylab
 - Hubble Space Telescope
 - Space Shuttle
 - X-33
 - Space Station
 - SLI

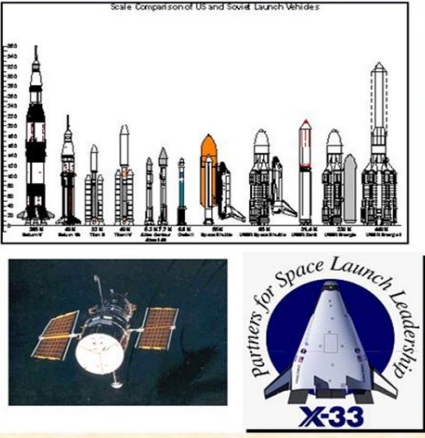

6

Figure I-1. Example Projects that Formed Basis of the Lessons

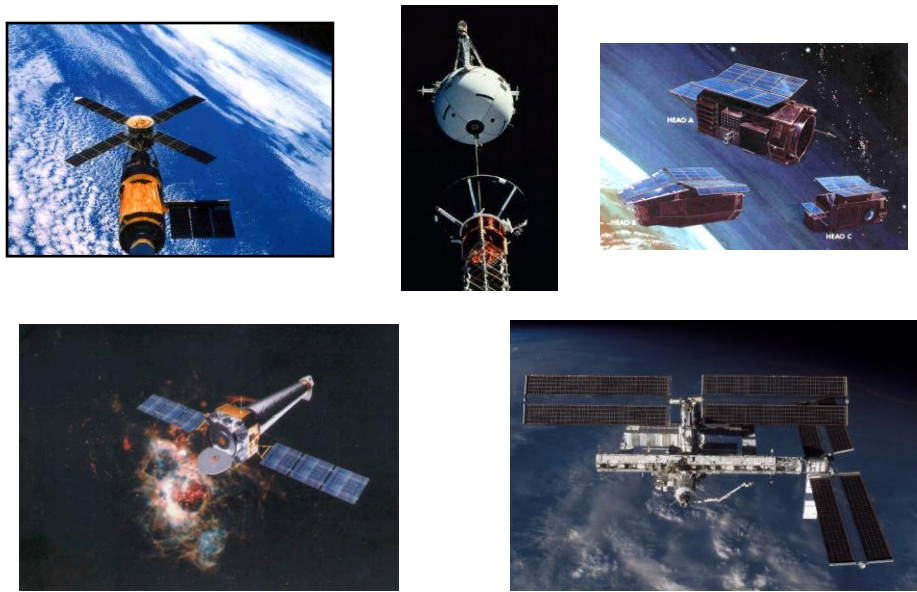

Figure I-2. Example Projects that Formed Basis of the Lessons –cont’d.

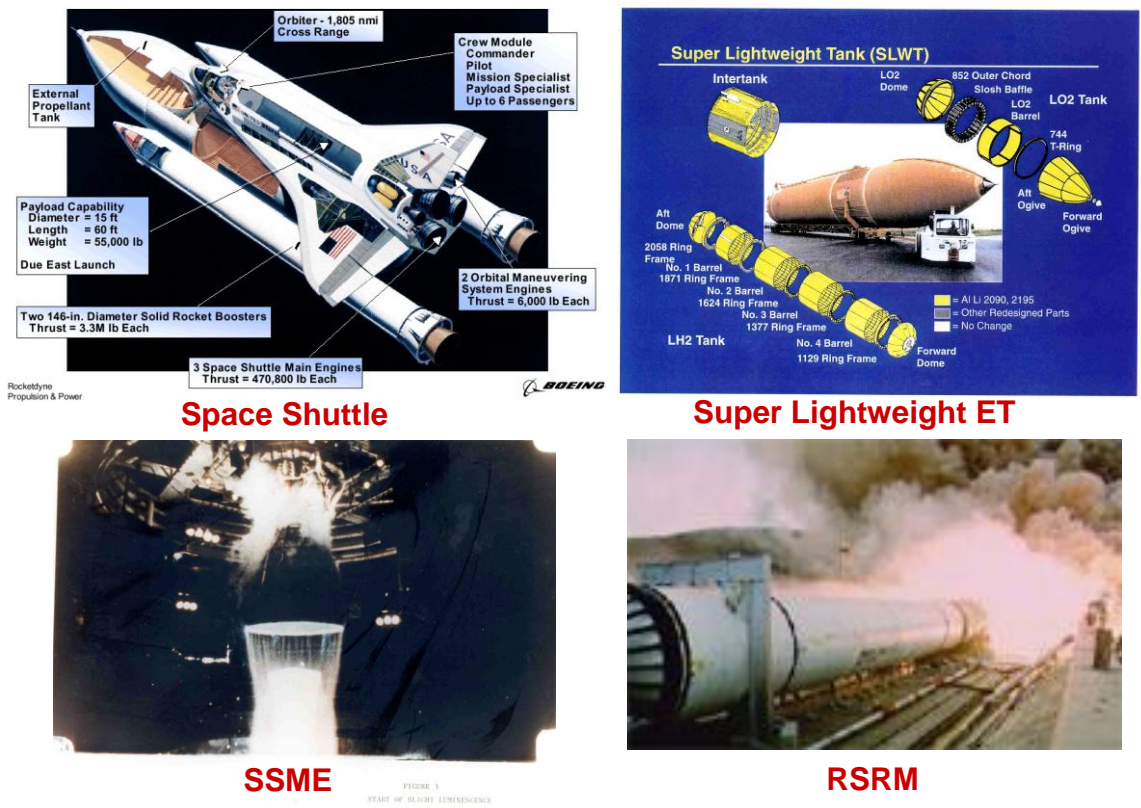

Figure I-3. Example Projects that Formed Basis of the Lessons – cont’d.



**Figure I-4. Example Projects that Formed Basis of the Lessons – cont’d.
Lessons Learned Process**

The process used for developing and describing the “Lessons Learned” starts with the listing of various project experiences and problems from which we developed the lessons. We limited the projects and lessons to those that the authors had experience with. There are many other lessons in our collection which others have developed which are a rich source for the reader to explore. We next grouped the observations into generic and technical categories. We first subdivided the two categories into more definitive categories as shown on Figure I-5. Under these categories the observations were then grouped as lessons derived from the observations. Top level principles of design and management were distilled from these lessons.

Basis and Applicability of Lessons

- ✦ From our experience, which has been primarily in technical integration and flight mechanics, we have derived lessons and distilled principles that are general in nature and apply across all engineering.
- ✦ The general lessons and principles can be supported by examples from disciplines other than those of the authors’ experience.

- ✦ In addition to these general lessons, there are also discipline-specific and component-specific lessons that are not addressed in this course. They are available from other sources such as the NASA and Center Lessons Learned databases, Lunar e-Library (Materials Division), etc.

Lessons Learned Process

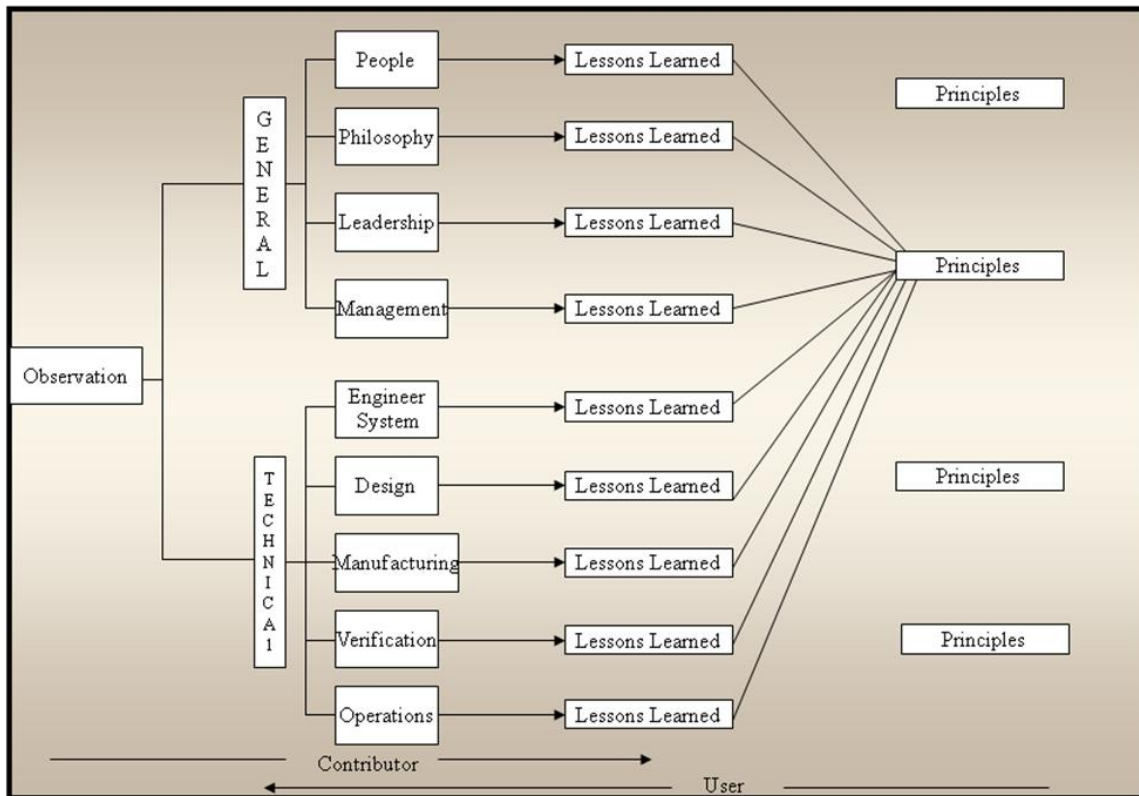

10

Figure I-5. Lessons Learned Process

The top level principles are listed below, with associated corollaries. Principle 1 deals with the importance of people. Most of everything we do depends on the judgment and decision making skills of our people. People are the most important resource an organization has. In fact, all infrastructures exist as an aid to the human personality and mind. Principle 2 deals with how the challenge of putting systems in space drives everything, including all analysis and test and the project design. Principle 3 deals with the system interactions and the fact that all the parts are interacting elements of the system. Communications is a key to understanding this systems aspect of a project or program. Principle 4 is fundamental in that everything is governed by the laws of physics. In a broad sense this also includes the basic principles of finance, organization, etc. Principle 5 deals with need for robustness and the understanding of sensitivities, uncertainties, risks and margins of the system.

Principle 6 says that we must design a product for its total life cycle, not just one phase. Principle 7 says that testing and verification are essential to developing a good product. Principle 8 deals with the need for critical thinking and having a culture that listens, thinks creatively and questions critically. Principle 9 goes back to the people and deals with the importance of leadership. Each of the principles will be discussed in more detail in the following sections of the report.

Lessons Learned Principles

- I. System success depends on the creativity, judgment, and decision-making skills of the people**
 - People are our most important resource
- II. Space systems are challenging, high performance systems**
 - High energy, high power density
 - Therefore, high sensitivity
- III. Everything acts as a system (whole)**
 - We design by compartmentalization and reintegration
 - Understanding interfaces and interactions is crucial
 - Requires pervasive communications
- IV. The system is governed by the laws of physics**
 - Reality can't be ignored
 - Look to the real performance of the hardware and software
- V. Robust design is based on our understanding of sensitivities, uncertainties, and margins**
 - Must consider sensitivities, uncertainties, margins, risks
 - Aim for robustness
- VI. Project success is determined by life cycle considerations**
 - Program constraints can result in a non-optimal design
 - Requirements can drive the design in unexpected ways
 - Early phases of project most influential on design
 - Design must consider full life cycle including manufacturing, verification, and operations
- VII. Testing and verification have an essential role in development**
 - We understand by testing
 - Must know limitations
- VIII. Anticipating and surfacing problems must be encouraged**
 - Critical thinking
 - Think out of the box
 - Listen
- IX. Leadership is the foundation**
 - Integrity
 - Outward focused
 - People centered

Another way of visualizing the lessons is shown Figure I-6 as a triad of Insights, Integration, and Individuals. *Insights* deal with principles, physics of the problem, critical thinking, creativity and discoveries. *Integration* deals with the system and subsystems, their uncertainties, sensitivities and trades, while the *Individuals* leg deals with leadership, people skills, communications etc. Only representative items are included. *Insights* are the basic principles that we see from the lessons and the discoveries they reveal. *Individuals* involve the individual skills and organizational characteristics. *Integration* covers the complex interactions which occur within complicated space systems and the process of making the total system perform successfully.

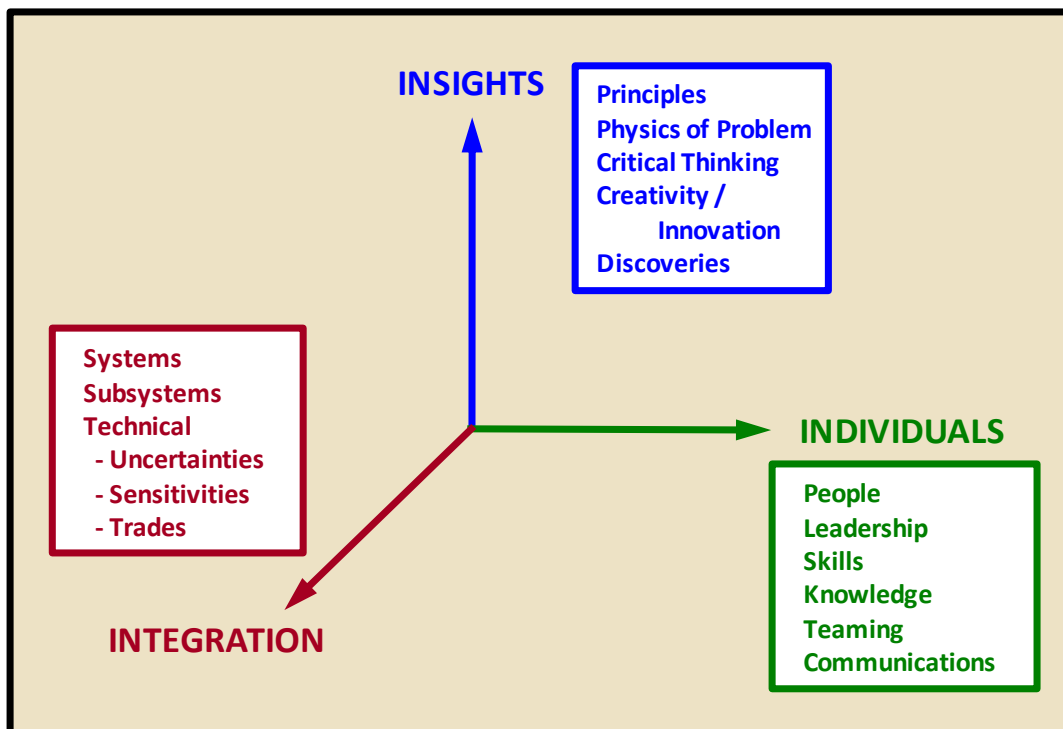

Figure I-6. A Triad of Principles and Lessons Concepts

We have grouped the twenty-seven Lessons Learned under the nine Principles discussed earlier. The Principles and the Lessons grouping becomes the outline for discussion for the rest of the report as shown below.

Listing of Principles with Supporting Lessons

- I. **System success depends on the creativity, judgment, and decision-making skills of the people**
 1. People Are the Prime Resource for Project Success
 2. People Skills are Mandatory for Achieving Successful Products

- II. **Space systems are challenging, high performance systems**
 - 3. Demand for High Performance Leads to High Power Densities and High Sensitivities
- III. **Everything acts as a system (whole)**
 - 4. Systems and Technical Integration
 - 5. Risk Management
 - 6. All Design is a Paradox, a Balancing Act
- IV. **The system is governed by the laws of physics**
 - 7. Physics of the Problems Reigns Supreme
 - 8. Engineering is a Logical Thought Process
 - 9. Mathematics Is The Same!
 - 10. Fundamentals of Launch Vehicle Design
- V. **Robust design is based on our understanding of sensitivities, uncertainties, and margins**
 - 11. Robustness
 - 12. Understanding Sensitivities and Uncertainties is Mandatory
 - 13. Margins Must Be Adequate
- VI. **Project success is determined by life cycle considerations**
 - 14. Design Space Constrained by Where You Are in the Life Cycle
 - 15. Concept Selection and Design Process
 - 16. Requirements Drive the Design
 - 17. Designing for the -ilities and Cost
- VII. **Testing and verification have an essential role in development**
 - 18. Hardware and Data Have the Answers
 - 19. Can Test Now or You Will Test Later

 - 20. Independent Analysis, Test, and Design Keys to Success
 - 21. All Analyses and Tests are Limited
 - 22. Scaling is a Major Issue
- VIII. **Anticipating and surfacing problems must be encouraged**
 - 23. Must Hear and Understand All Technical and Programmatic Opinion
 - 24. There are No Small Changes!
 - 25. Expect the Unexpected
- IX. **Leadership is the foundation**
 - 26. Integrity
 - 27. Focus Beyond Yourself

Discussion of Lessons Learned Principles

In the following sections we will divide the report by the Principles shown above. For each Principle, there will first be a discussion of the principle category in general, followed by a listing of the lessons supporting that principle, along with sub-categories of the lesson. Included will be a listing of the various problems/projects used to create the lesson. The format will be: The lesson with corollaries is stated along with a listing of the project problems the lesson is drawn from, then each problem is illustrated and discussed with conclusions drawn in terms of Lessons Learned.

Principle I: System Success Depends on the Creativity, Judgment, and Decision-Making Skills of the People

- 1. People Are the Prime Resource for Project Success**
- 2. People Skills are Mandatory for Achieving Successful Products**

What we have found is that of all the resources and skills required for project success, people are number one; everything else comes in second. We will discuss this category under the above two lessons:

Lesson 1: People Are the Prime Resource for Project Success

- ✦ ***People are the prime resource. Engineer's judgment and creativity are the key to quality engineering. All other resources are an aid to the human mind.***
 - ✦ **The complexity of the system requires applying judgment and innovation to the specific situation. Dogma, rules, or recipe cannot supplant this.**
 - ✦ **Tools enhance efficiency, but cannot replace judgment and creativity of the human mind.**
 - ✦ **Guidelines and criteria should be tailored or adapted to the particular project, to avoid a dogmatic approach, which unnecessarily constrains design solutions.**
 - ✦ **Many decision gates are not explicit, but are judgment based, requiring in-depth system knowledge and wisdom.**
 - ✦ **The level of penetration is an engineering judgment, determined by project characteristics, phase, sensitivity, and uncertainty.**
 - ✦ **Reward all expressions of creativity.**

The sub-topics of the general lesson that people are the prime resource state clearly that we cannot just depend on process and procedures to obtain a successful product; but, that the complexity of our space systems depends on the judgment and innovation of the people of the organization to create, build and manage a successful system. Dogma and rules, although they can guide and are necessary, can never replace this judgment and creativity of the human mind. In the end the human mind trumps. The same can be said of tools. We need process, procedures, criteria and guidelines but they should never be used to replace the creativity and the human judgment. We use these tools to aid in decision making but in the end most decisions are human judgments based on wisdom and understanding. One of the big questions design and operations of space systems raises continually is "When is enough good enough for the system." Our tendency is to be risk averse and add detail way beyond what is good enough. Human judgment and creativity should be applied in all aspects of space operations. The organization should reward all expressions of creativity of its people and not have an organization governed by fear of failure.

The complex technical and managerial problems we face depend on human judgment, creativity, and innovation for solutions. All our other tools are aids for the human mind in the performance of these tasks. Our job then is to bring out and develop these human resources. There are many examples that illustrate the value of human resources and how they have been rewarded. This creativity exists in many forms as illustrated next. The basic lesson is that we must reward all forms of creative actions of our people and start development of processes to remove inhibitors which suppress the creative actions of its people.

Creativity exists in several forms.

1. Technical expression
2. Artistic expression
3. Naming of hardware parts
4. Musical expression

Reward all forms of creativity expressed by the people.

Examples for Lesson 1 are:

- Rich Holman
- Honeywell Calendars
- Jupiter Propellant Sloshing Solution. "Beer Cans"
- Synthetic Wind Profile
- SSME LOX Pump Silicon Nitride Bearings
- Tethered Satellite Skip Rope Damper

Rich Holman

In the early Apollo days there was an engineer, Rich Holman, at McDonnell Douglas who drew cartoons of the Saturn IV B problems and the personalities involved in the problems. McDonnell Douglas thought the value of the cartoons was so great that they

published a selected group in a little booklet titled “Nicely Drawn by Rich Holman”. [Holman, Special document] We have selected two of these to illustrate the content and value. Figure 1-1 deals with a problem we had with the dynamic response of the engine gimbaling actuators. The actuators were coupling dynamically with the thrust structure creating an undesirable high response, which compromised the controllability of the vehicle. Rich summed up the physics of the problem by saying that it only hurts at resonance. The people involved that were not convinced were the recipients of the statement. The name of Eggleston on the badge is one of the SIVB Stage Program managers that were having trouble accepting the existence of the problem. Rich’s cartoons not only dealt with the physics of the problems but the human involvement as well. Figure 1-2 had to do with a control feedback potentiometer that was giving a problem. Getting rid of the potentiometer required the addition of additional elements that increased the complexity of the system. In those days the potentiometer was a series wound coil which the wiper arm moved across to create the signal. Each time the wiper arm encountered the next winding of the coil, the signal would jump in amplitude, creating a series of frequency pulses. The frequency of the pulses was introduced by the speed the arm was moving. This series of pulses was creating a dynamic problem. The quote; “But it does get rid of the feedback pot”, sums up the principle, that adding complexity creates additional problems. The cartoon illustrates this by the number and complex arrangement of parts in the base region of the SIV B Stage.

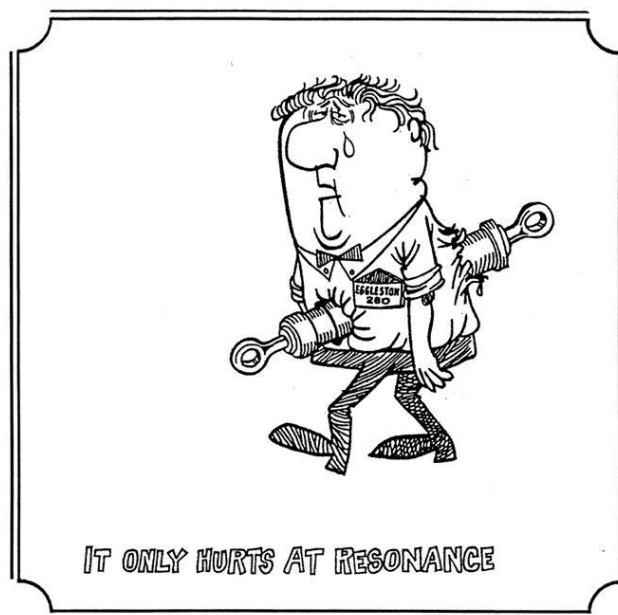

Figure 1-1. It Only Hurts At Resonance



Figure 1-2. But It Does Get Rid of That Feedback Pot

Honeywell Calendars

In this same time period Honeywell Corporation put out calendars with cartoons drawn by Bill Eddy that were of the same character as was Rich's. The cartoons were published by Minneapolis Honeywell in two books [Eddy, 1956] and [Eddy, 1962]. We have chosen three of these monthly calendar cartoons: Figure 1-3 is one of our favorites which illustrates that all details are important. It shows the importance understanding any anomaly before proceeding; as the bridge that doesn't connect because of the design error of a decimal point. Figure 1-4 shows the importance of capturing early and controlling requirements versus letting requirements grow and change uncontrolled. Space programs have been replete with large cost growth due to changing requirements. Figure 1-5 deals with the Alaskan oil pipeline where they were painting it from different ends and when they met the colors were different. (Not an actual happening) It illustrates the concept that one must stay with the specifications and requirements or push back on the system so that the design is consistent.

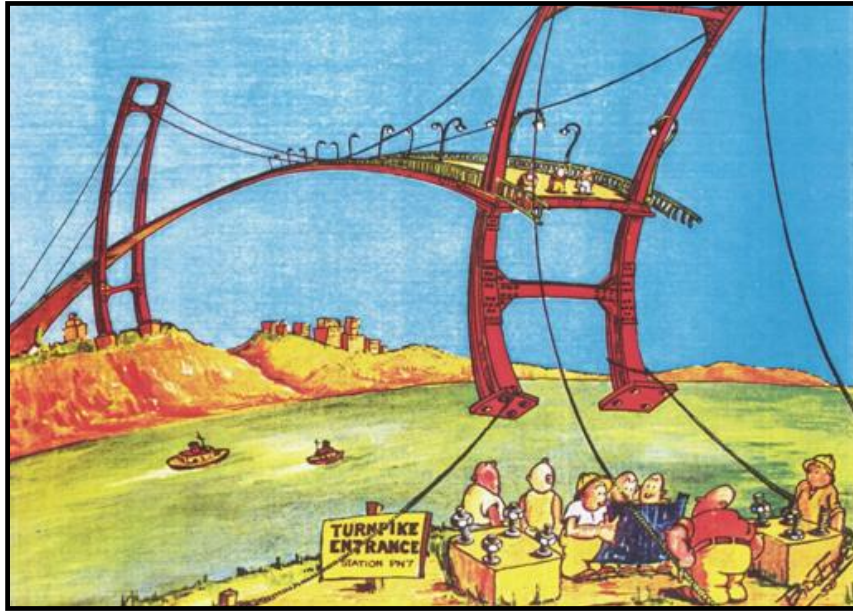

Figure 1-3. So That Decimal Point Indeed Was A Fly Speck

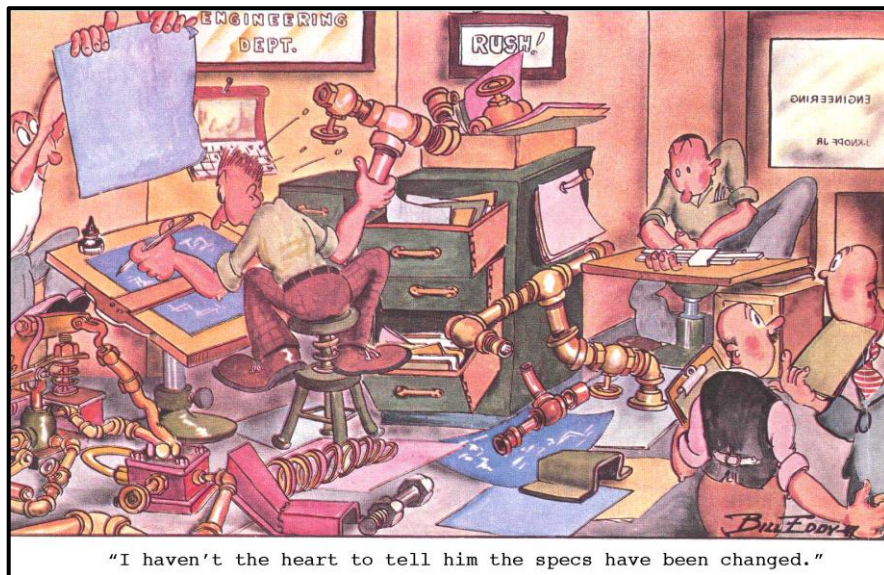

Figure 1-4. Changing Requirements

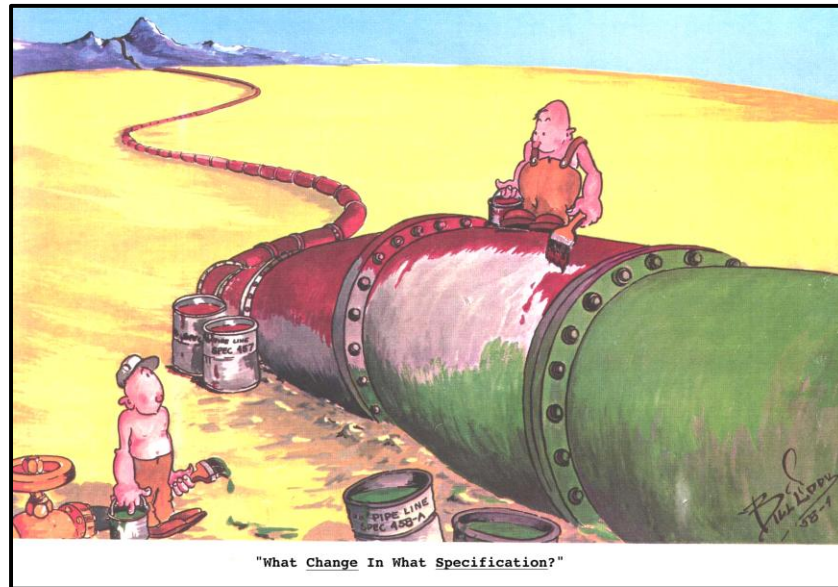

Figure 1-5. What Change in What Specifications?

Jupiter Propellant Sloshing Solution. "Beer Cans"

We lost the first Jupiter missile due to an engine plume recirculation problem burning the actuator control wires. The second Jupiter launch was lost due to propellant sloshing dynamics coupling with the control system. [Ryan, September 1996; Abramson, SP-106, 1967; Abramson, SP-8031, 1969]. The control system was saturated and vehicle control was lost at max q . The first problem was fixed with the installation of a heat shield where the gas generator exhaust was dumped overboard; however the second problem required more work and engineering creativity. No analytical models existed for characterizing the dynamics of liquids in a tank, and this type of experimentation was an emerging technology. The problem became the instigator for a long term analytical and experimental technology development. Helmut Bauer at NASA and Norm Abramson at Southwest Research Institute were the leaders in this effort. [Bauer, 1964] However, this effort was downstream and we needed a quick solution so that Jupiter 3 could be launched on time. We took the Jupiter LOX tank and put it on an empty railroad car and filled it with water. We then bumped the railroad car against the spur railroad stop, exciting the liquid dynamics. A movie camera recorded the motion and we were able to derive an equivalent slosh mass and frequency to be used in a control feedback simulation. The question then was: "What is a fix for the problem?" so that we could launch the next vehicle. Someone said that when they were back on the farm and had to haul water in steel drums in a wagon, that they floated pieces of lumber on the surface to keep it from sloshing. Well, lumber would not work in a missile, but floating something would. The original design was a perforated cylinder truncated with cones and had a commode float inside to make it float. The entire surface was filled with these devices called

beer cans. We then put these in the tank on the railroad car and demonstrated that they would indeed suppress the sloshing. They were eventually flown on Jupiter. See Figure 1-6.

Later, through analysis and sub-scale testing, we developed the baffle approach making the perforated baffles a part of the ring stiffeners. See Figure 1-7. This approach was used on Saturn and saved weight by having the baffles also perform part of the stiffening required to prevent tank buckling etc. Shuttle used baffles attached to an inter-frame instead of the ring frames due to manufacturing and operational requirements.

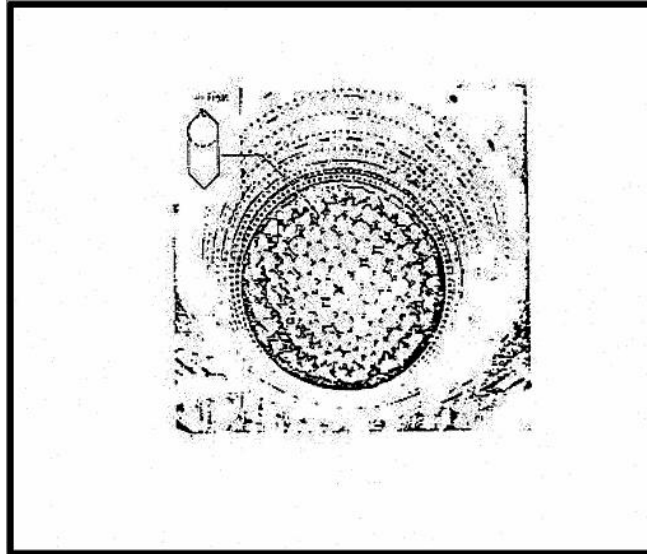

Figure 1-6. "Beer Cans" Flown on Early Jupiters

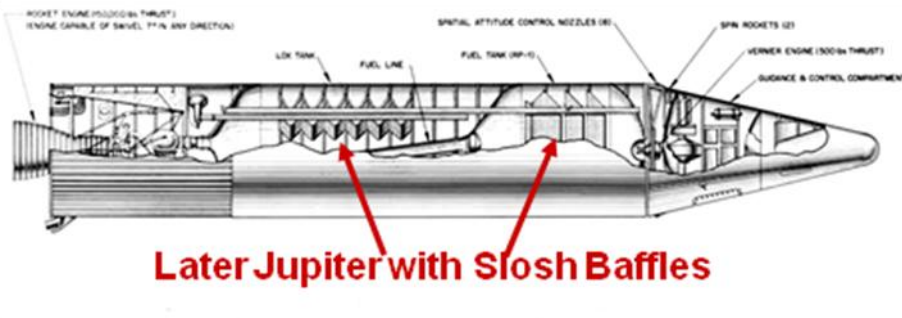

Figure 1-7. Later Jupiter Configuration with Slosh Baffles

Synthetic Wind Profile

Early in Saturn development, we were challenged with the problem of representing the atmospheric wind characteristics in a manner that would allow 6-degree of freedom control and vehicle dynamic simulations to provide time consistent 3-sigma response data for structural design. Two creative ideas were required to meet this goal. The first involved a way of taking each single parameter 3 sigma run of the 6-DOF response run and comparing it to a nominal run, extracting the differences for each response parameter. These deltas were then root-sum-squared (RSS'd) and added to the nominal, producing the 3-sigma design values. The problem was that this discrete value was needed in combination with all other parameters in the time consistent manner in order to have a balanced load set. Jud Lovingood came up with a way of taking the 3-sigma deltas and ratioing them with the nominal to generate a ratio for the input parameters, which then provided a 3-sigma time consistent response. [Lovingood, J.A. 1964] In addition we needed a way of having the wind characteristics modeled in a time consistent manner for a forcing function for the 6-DOF simulation. Helmut Horn, Jim Socggins, Bill Vaughn and Robert Ryan came up with the synthetic profile based on a 95% wind speed and RSS'd 99% wind shear and square waved wind gust. See Figure 1-8. This was used very successfully in the early design of Saturn. [Geissler, E.D. et.al.1970] The need arose to have a more realistic representation of the wind shear and gust, so a monthly set of detailed measurements were measured over a few years timeframe, that had the wind gust and shears correct to 50 meter lengths. Using these detailed Jimsphere wind profiles a Monte Carlo approach was used to verify that accelerometer feedback load relief was not effective. As a result Saturn V flew without load relief. (See Lesson 6) [Ryan,R.S. January 20-23,1969; Geissler, E.D. et.al. 1970] Since then a vector wind model and the Global Reference Atmosphere Model (GRAM) wind model have been developed for use in Shuttle and new programs.

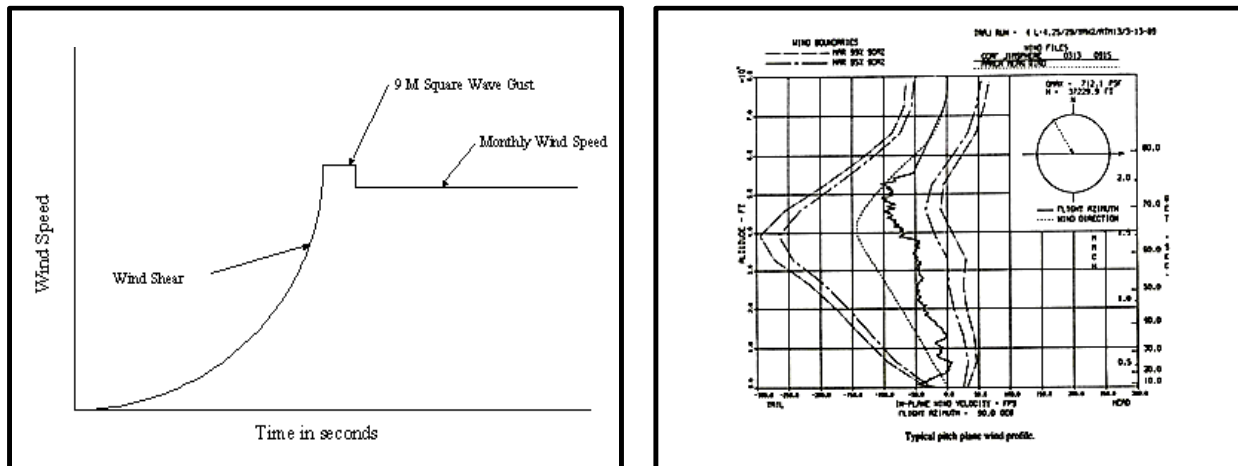

Figure 1-8. Synthetic and Measured Wind Profile Approach

The need for and the application of this approach is summarized as:

- Control and Loads response analysis requires time-consistent data.
- Question: How do I generate this time-consistent data from a root-sum-squared (RSS) peak value from perturbed individual response runs?
- The *A-Factor approach* ratios the individual perturbed peak values to the RSS'd value, to obtain parameter scaling factors, which will produce a time consistent run with the peak value matching the RSS'd. This produces a time-consistent data set for all response variables at a 1-sigma level

SSME LOX Pump Silicon Nitride Bearings

During Space Shuttle operational flights, liquid oxygen (LOX) pump bearings were a major problem, as were other elements such as turbine blades and welds. Bearings would wear out very quickly and along with other problems led to a requirement to refurbish the pumps after every one or two flights. Alternate turbopumps were proposed as a solution to these problems. The development of the alternate LOX turbopump was having major issues with the pump end bearings in that they would overheat and wear out in the first 50 seconds of run time. This problem was threatening continuation of the program, and needed a quick solution. A team was formed to find a solution to the problem. They tried everything with nothing working. Prior to this team's formation a MSFC engineer Dr. Robert Thom, was thinking out of the box and came up with use of Silicon Nitride (SiNi) ball bearings and had a technology program in place to test the bearings in a bearing tester. The team was near the deadline of program cancelation unless a solution was found, when we decided to try the new SiNi balls. [Gibson, Jannaf-1354] Silicon Nitride is a ceramic material. A manager of Pratt & Whitney was reluctant to try them and had said no one would put glass balls in his pump. A Pratt engineer took him into the shop and put a new ball bearing in a nylon sack and had him hit it with a large sledge hammer. The anvil and the hammer were dented, but the ball had no fracture under microscope inspection. As a result we started testing the balls in a pump and surprisingly there was no wear of the balls or the race. The results have been that pumps can fly 20 times with no bearing wear. See Figure 1-9. Currently, all space shuttle turbopumps have these SiNi bearings.

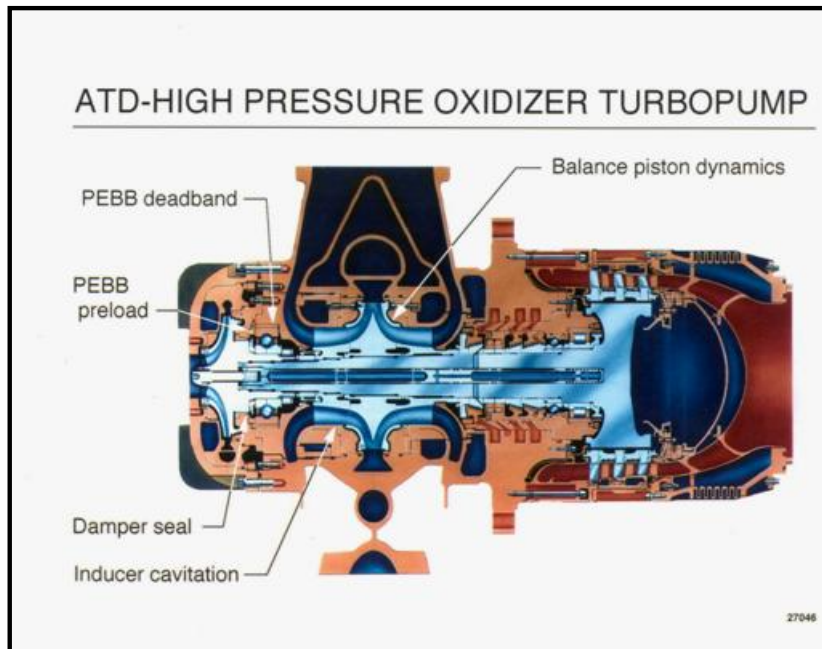

Figure 1-9. Alternate SSME LOX Pump with Silicon Nitride Ball Bearings

Tethered Satellite Skip Rope Damper

Tethered satellites have many technical features that are desirable. They can be used for power sources, orbit changes etc. However, implementing a Tethered Satellite had major design problems. As the satellite was deployed on a tether, the tether would set up dynamic oscillations (skip rope), which in the end could destroy the system. A team was formed to solve the problem through analysis and test. It was clear that some means of damping the oscillations was required. The approach was to install a damping system in the tether output ferrule using negator springs. As the tether dynamically moved, the dampers on the end of the cable attached to the eye through which the tether was deployed would move with the dynamic motion, thus damping the skip rope. After much testing the system was verified and flew very successfully on the first tether flight. See Figures 1-10 through 1-12 for details.

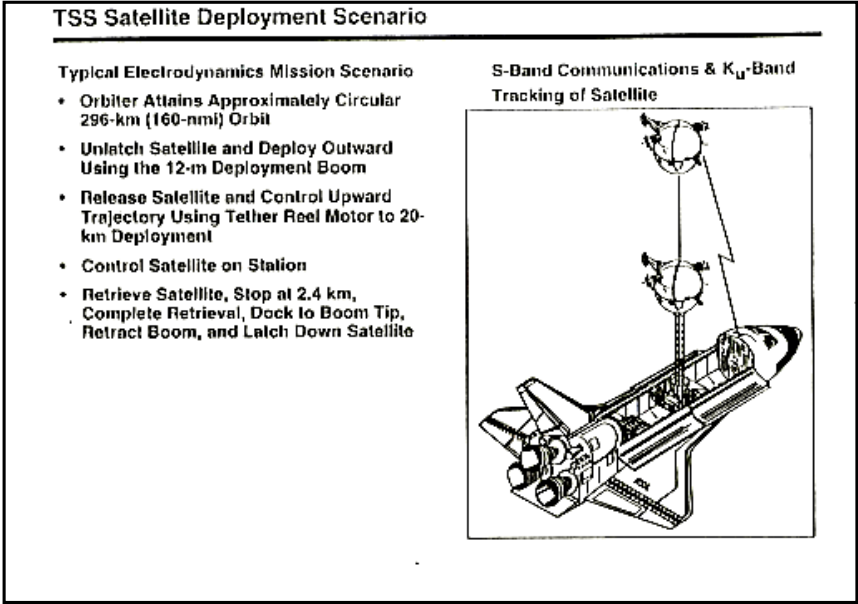

Figure 1-10. Tether Deployment Scenario

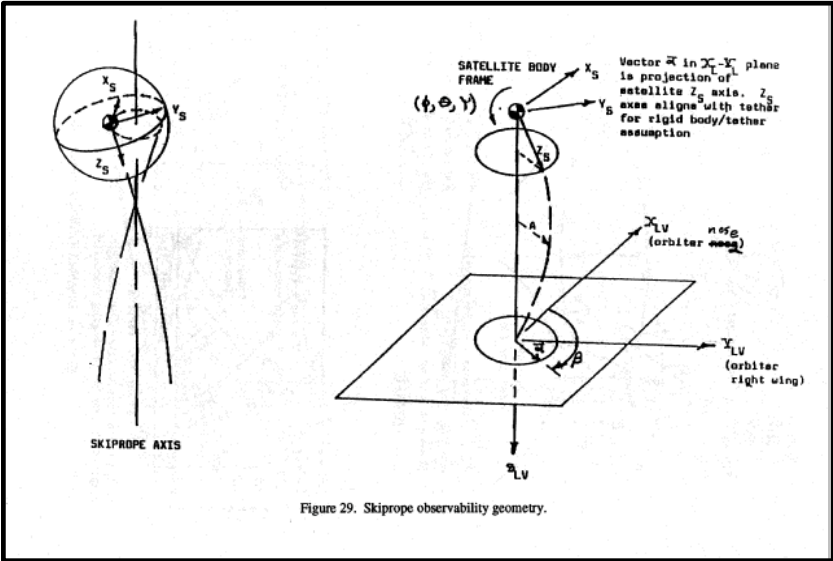
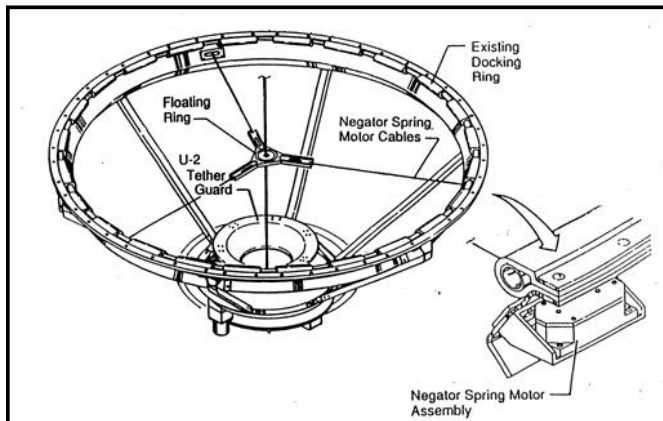

Figure 1-11. Tether Skip rope Characteristics



- Tether skip-rope was stabilized using an **innovative damper mechanism**.
- The dampers were on the ends of motor cables attached to a floating ring through which the tether passed.

Figure 1-12. Tether Skip Rope Damper

What we have illustrated with these examples is how innovation and creativity of the human mind has resulted in the solution to very complex problems. It is mandatory that the individual and the organization be provided the opportunity for the free expression of this creativity and employ both means for its development and rewards for its expression. [Mowery, D.M., et.al., 1993]

✦ **A key message from Lesson 1:**

***Reward Judgment and Creativity.
Dogma, rules, and recipes stifle Critical Thinking***

Lesson 2. People Skills Are Mandatory For Achieving Successful Products

✦ ***Although engineering skills are essential, people skills are mandatory for achieving successful products.***

- ❑ **Choose a strong leader with decision making capability who listens and encourages everybody to integrate.**
- ❑ **Organization is the tool to accomplish the job; must provide leadership and motivation.**
- ❑ **Encourage engineers to enhance their cooperative interactive skills as well as their technical skills.**
- ❑ **Train engineers to be specialists with a system focus.**
- ❑ **Reward specialists to participate in integration activities in order to formulate a world view of the total system.**
- ❑ **Provide an open environment, which encourages innovation and stimulates communication.**

Since people are the prime resource in achieving project success, engineering skills are essential. However, that is not enough; people skills are mandatory for achieving success. There are a number of people skills, but the focus here will be on nurturing skills and developing skills associated with individual and organizational growth.

Nurturing skills requires strong leaders who can make correct judgments and decisions. They encourage everyone to interact and integrate (system focus), while keeping in the forefront the importance of technical skills. Leaders are mentors, teachers, and role models for technical integration and systems engineering. In those capacities, they advocate their views while inquiring the views of their reports. Everyone knows the leader's goal is the search for the best balanced design, technical solution, or truth, all with a system focus. They demonstrate the nurturing process through example while providing an open environment where innovation and communication are encouraged and the fear of failure is minimized. These leaders inspire and motivate everyone to accomplish their goals with passion.

An important aspect of people skills has to do with providing people a means for achieving personal and organizational growth. There are numerous subjects associated with individual and organizational growth. The select list below represents some that have been found to be beneficial. Each will be discussed briefly and references provided for further understanding.

Characteristics of Individual and Organizational Growth

- A. The Principle of Attitude
- B. Tree of Life
- C. Senses Involvement
- D. Aperiodic Reinforcement
- E. Hierarchy of Needs
- F. Law of Readiness
- G. Must Lose to Gain
- H. Expectancy Theory (Pygmalion Effect)
- I. Follow-up and Feedback
- J. Role Modeling
- K. Guidance and Control Theory
- L. Communication

A. The Principle of Attitude

The mind is one of the keys to growth. A person's attitude is the fuel of growth. Whitmore shows an interrelationship between the attitude of the mind, knowledge (technique) and experience (fitness). [Whitmore, 1997] Figure 2-1. The openness of the mind influences how our attitude changes, what we acquire, and the experience we achieve. Knowledge has

to do with the technique of the job while experience relates to the fitness to accomplish the job. If we think we have all the answers, we are not open to new knowledge or experience. Hunger for growth is important, as is humility. Humility means that we are trainable.

Closely related to the principle of attitude is *The Law of the Mind*. “Whatsoever a man thinketh, so is he.” Earl Nightingale said it like this: “Whatsoever a person indelibly impresses on the mind will one day be expressed.” He said that, “The mind will marshal the resources required to accomplish the goal.” [Nightingale, 1990, 1997] Some have said that if it can’t be done ethically, then it will be accomplished unethically. There is a warning implied: “Be careful what you impress on the mind.”

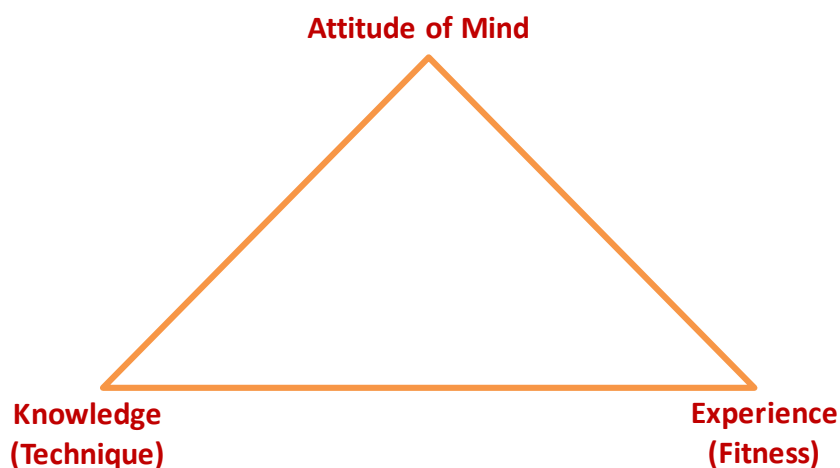

“Coaching for Performance” by John Whitmore

Figure 2-1. Principles of Attitude

B. Tree of Life

In all stages of our lives we have various diverse roles to accomplish. For the most part, this creates conflict because: 1. there are many; 2. they can be intense; 3. they can be time consuming; and 4. they can be conflicting. As a consequence, major frustration can be experienced. There is a need to identify and understand all our roles and then determine how to deal with them. [Covey et. al., 1994], provides some insights by relating our principles, mission, and roles to a tree, thus “Tree of Life.” Figure 2-2 is an adaptation from Covey.

Roles must be balanced

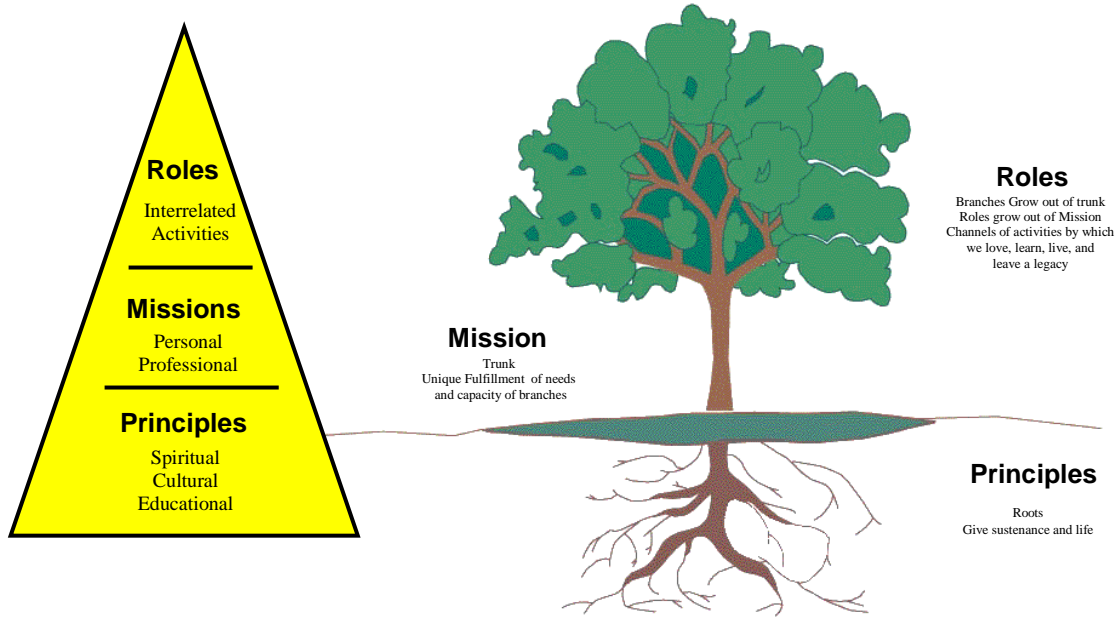

Balance means all parts working synergistically in a highly interrelated whole
Balance isn't "either/or" → it's "and"

Figure 2-2. Tree of Life

When we look at the Tree of Life we see a growing life form that is strong, healthy, colorful, and pleasant to look at. The main elements of the tree are the roots, trunk, and the branches. The roots provide the necessary sustenance while the trunk fulfills the needs of the branches, i.e., food and strength. The branches grow out of the trunk. They provide nourishment for the system and aesthetic value. Each of these elements have specific functions, but for the tree to attain its strength and beauty these elements must work together to achieve balance. Balance is achieved when all parts work together achieving synergism to accomplish the strength and beauty of the highly interrelated whole tree.

The diversity of our roles at various stages of our lives can create conflict and frustration. If we make a comparison between key aspects of our lives and the tree of life, there are similarities that are helpful. For instance, see Figure 2-2. In this figure we have principles, missions, and roles. These are analogous to the elements of roots, trunk, and branches of the tree. The principles in our lives are spiritual, cultural, and educational. They are the foundations upon which we set achievable goals, determine our paths, and make decisions. Our mission in life is mainly related to the personal and professional life style and occupation we choose. Our mission determines the roles that we have to carry-out for our missions to be successful. When we consider our personal and professional roles there can be considerable diversity that can lead to frustration. There is a demand for our time, capability, participation in number of activities, complications, etc. To complicate matters, as we were

growing-up into adulthood, we learned to compartmentalize our activities;” I’ll either do this or that.” In consideration of the number of roles we have, if we continue to compartmentalize our roles it will lead to pain in personal relationships and retard personal growth. Like the “Tree”, our roles are parts of a highly inter-related whole where balance is needed. Recall, balance in the tree is achieved when all parts work together. Our roles appear conflicting and unrelated because we have not figured out how to make everything work together. Balance is not “I’ll either do this or do that.” We will see that balance means “I’ll do it all.”

Our initial look will focus on how to achieve balance in executing the activities associated with our roles. At first when all the roles are considered, it may look like an insurmountable monumental time consuming effort that no one could accomplish. In fact, it turns out that most of our roles are “parts of an interrelated whole that work synergistically”. After it is understood how the various roles play together and how they can be conditioned, our attitude relating to dealing with them will change and there will be a reduction in frustration. Instead of fighting the notion of all the “things” that must be done “now”, accept it as a challenge. For instance, “my hobby will be conquering my roles.” I’ll interact with all those close to me, i.e., I’ll let them know I have accepted the challenge and invite them to participate. They are now partners with me in my new hobby. Then as part of the challenge, put things in an appropriate perspective. Firstly, consider the time it takes to accomplish an activity. Sometimes deadlines are levied without any notion whatsoever regarding how long an activity will actually take. Also, if there is a real short- fuse deadline, make sure it is understood that the results will be a short-fuse result. Occasionally, everything can be dropped for a better than short-fuse result, but all of our activities can’t run in the short-fuse timeline mode. Thus, the timeline of our activities must be understood and balanced. Secondly, consider the magnitude of the activities. Could it be that we can’t tell what is important (big rocks) and what is not (sand pebbles)? When a set of activities is initiated, it might be difficult to determine what’s important. The sensitivity of the outcome to the various activities has to be determined, i.e. what are the consequences of not doing a specific activity or reducing the level of effort. After the big rock activities are determined, what is their sequence? Thus the balance of the effort of the activities is determined. Now the important activities and their timelines are known and balanced.

At this point it will be observed that our hobby has activities where parts fit together into an interrelated whole that work synergistically. Now instead of doing this or that in a piecemeal frustrated fashion, all the balanced activities are being accomplished in a harmonious commanding fashion. I have taken charge of my roles!

C. Senses Involvement

When Bob Ryan was studying education, one professor emphasized the principle, *“The more senses you involve in the experience, the greater the learning retention.”* (Touch, sight, sound, taste, and smell). Our experience in engineering has verified this principle. Engineers that see, touch, test as well as analyze hardware, in order to understand engineering design better, will produce better products. Learning and understanding is further enhanced if they have struck a weld, cut a line, made a dove tail joint etc. As a result we

worked hard to have our engineers in the plants where the hardware was being produced, tested etc. Ferguson at MIT recognized this, discussing it in great detail, emphasizing that educational Institutions must change their approach to teaching engineering, getting the students to where the hardware is being produced. [Ferguson, 1992]

D. Aperiodic Reinforcement

Aperiodic reinforcement, developed by Skinner and Watson, says that the learning retention is proportional to the lack of periodicity of the reinforcement. If the reward is given after every successful attempt the learning retention is short. If the reward is aperiodic, the knowledge of when the reward comes is unknown, hence the learner works harder for the reward and the learning retention is greater. Aperiodic reinforcement is a powerful tool in developing skills/ behavior. The lesson is clear, reward the effort but do so on an aperiodic basis for best results. [Skinner, 1972]

E. Hierarchy Of Needs

Understanding and fulfilling our needs are necessary elements that can improve motivation. The associated knowledge can be acquired by understanding Maslow’s hierarchy of needs as is shown in Figure 2-3.



Fig 2-3. Maslow’s Hierarchy

Dr. Abraham Maslow was born April 1, 1908 and died June 8, 1970, [Boeree, 2006] His contributions were primarily related to human behavior and motivation. In one of his early publications he conceptualized his basic theory where he delineated fundamental needs of man [Maslow, 1943]. Then in 1954 those needs were visualized in a hierarchy as shown above where the lower four needs are deficiency needs and the top need is a growth need [Maslow, 1954]. Within the deficiency needs, the lower level needs must be satisfied before going to the next level. If one of the deficiency needs is removed at some later time (I have no food), then we will act to relieve the deficiency (I have food).

In the years that followed, Maslow determined that there were additional growth needs [Maslow, 1971] and [Maslow and Lowery, 1998]. Thus, the hierarchy was expanded. While the expanded hierarchy is not shown in the figure, insight is provided below for understanding. The expanded list that follows is a summary of all of Maslow's needs in ascending order.

Deficiency Needs:

1. Physiological: food, water, bodily comforts, ...
2. Safety: out of harm's way, ...
3. Belonging: family, friends, ...
4. Self-esteem: self-respect, respect of others, competent, ...

Growth Needs

5. Cognitive: knowledge, understanding, searching, ...
6. Aesthetic: symmetry, order, beauty, ...
7. Self-actualization: to be the best we can be, ...
8. Self-transcendence: help others realize their potential

Despite the fact that there is no scientific evidence to support Maslow's hierarchy, it is widely accepted based on anecdotal evidence. Further understanding of Maslow's conceptualization of human behavior and motivation can be found in [Boeree, 2006] and [Huitt, 2004]. While numerous insights can be investigated relating to human behavior and motivation, the focus will now be on self-esteem and self-actualization.

Self-esteem can be thought of as one's overall self-appraisal of their worth. It encompasses both beliefs and emotions and is reflected in behavior. In addition, it enables us to face the challenges in life and feel worthy of happiness. Maslow believed that we need the respect of others as well as self-respect. There are numerous activities that can be done to enhance self-esteem. Shown below is a short list which can be incorporated into our daily interactions with others.

1. Recognize, maintain, and enhance self-esteem
 - learn how to do it; show others by example
2. Listen actively and respond with empathy
 - I'm interested in what you have to say
3. Ask for help and encourage involvement
 - delegate instead of control; seek advice

4. Share thoughts, feelings, and rational
 - this is what I think; what do you think
5. Offer support without removing responsibility
 - help others achieve their goals; but, don't do it for them

In addition to the above, consider the following: spiritual activities, exercise, praising, achieving goals, dress style, integrity, generosity, good work ethics, education, being courteous, and so on.

Self-actualization is the desire for self-fulfillment; to strive to become actualized in what I am potentially, i.e., to become everything that I'm capable of becoming. In order for one to achieve their potential, time must be taken to understand one's self. Then take the appropriate actions to achieve your potential.

In learning organizations, provisions are in place to encourage personal growth. Listed below are some limited examples relating to what a learning organization should provide.

1. Define and clarify roles, goals, and values
2. Provide development opportunities
3. Provide coaching
4. Celebrate, recognize, and reward
5. Promote communication and trust (share information)

Delineated above are some ideas relating to understanding and fulfilling needs. These ideas are a snapshot aimed at providing an eye opener to achieve a highly motivated life style. Since everyone is different, each must find their own tailored needs. What are yours?

F. Law of Readiness

"The Law of Readiness" is essential to understand how individuals and organizations grow. [Thorndike, 1912] In essence it takes the meshing of the physical, the emotional, and the intellectual to create readiness. Until the blending occurs performance is not up to par. When they mesh performance is high and graceful. It takes time (patience), and experience (practice) to achieve readiness. When it happens it is obvious. You don't give up easily on people. Provide time for the "law of Readiness" to work. When coaching the 1955 Alabama Class "A" Basketball Championship Team Robert Ryan had a 6'7" center who was key to winning. John had a habit of rebounding the ball and then pulling it down to dribble or pass. We set up practice drills having him push the ball back to the goal or pass it out. Finally Ryan put a block over the goal so that the ball would bounce out for him to push back. After several weeks of this drill, Ryan was losing patience. John had no confidence and he couldn't get the hang of the principle. We worked one Friday and no progress was evident. Monday John came to practice performing the task with ease. Never again did he have to be reminded of the principle. Readiness works that way. Most of the time readiness appears to occur practically instantaneously but is built over a period of time. The authors have seen it work in areas of engineering, where all of a sudden everything fits. The process repeats as new skills are added.

G. Must Lose to Gain

Another principle of development, “Must Lose to Gain” is fundamental to growth. Figure 2-4 illustrates the principle using the trapeze artist. Growth implies first having a place of security from which to take off from. In this place one has social acceptance, equilibrium, control of one’s domain, good feelings, calmness, and status. To grow means turning loose and floating in uncertainty while reaching for the new. This turning loose is a leap of faith based on a challenge, encompassed with vulnerability, falling, and other undesirable risks. Leadership and management have the role of providing a safety net in case the employee falls so that they are not destroyed. Grasping the challenge means surrendering abilities, status, techniques, awards, becoming a nonconformist, many times risking financial security. A more disciplined life is implied along with commitment. In the end comes recognition, adventure, growth, power, but more importantly fulfillment. Growth always is anchored in choice; therefore “To grow means loss, and loss means mourning, so that newness can come in.”



Figure 2-4. Must Lose to Gain

When Robert Ryan went from being a dynamicist to a manager, giving up doing the analysis was very hard. Many times it would have been easier and quicker to accomplish the job himself, yet development of people meant turning loose and letting them do the job. When he moved to the position of deputy lab director the change was dramatic. Engineers, who felt free to come into his office before, now felt constrained. The furniture, the office size,

location, etc. was a turnoff to openness. After some times of frustration, he started going to the engineers instead of having them come to his office. This helped eliminate some of the feelings of isolation but never totally solved the problem. Other roles replaced the old roles and growth occurred. Growth always means loss [Tournier, 1966]. Recognition of the principle is very important. It explains why people are reluctant to give up the security, friends, etc. of the place to take on the adventure of discovering a new place. Choice is difficult because it means giving up something. Coaching and mentoring people will bring the coach and mentor in constant relationship with this principle as people are trying to grow by making choices.

H. Expectancy Theory (Pygmalion Effect)

People tend to learn/accomplish what you expect them to do. This is called the Pygmalion effect or principle. Let them know what you expect and believe they can do it. In general they will surprise you in what they accomplish. [Livingston, 1988]

I. Follow-up and Feedback Successive Refinement

Learning follows the principle of successive refinement. Figure 2-5 follows the *Learn, Commit, Do* spiral. Bob Guns shows the principle as five levels of learning. [Guns, 1996] They are acquisition, use, reflection, change and how. The process is repeated for each new learning activity. These principles and models strongly indicate that growth takes time. In other words you can't bypass nature. Many have said that on the average it takes 20 years to mature an engineer. Learning then requires commitment, action, then thinking about what happened and how, then making a change and repeating the process.

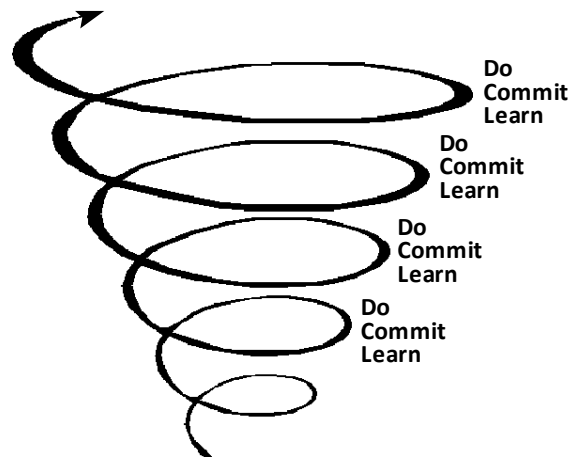

Figure 2-5. Model of Successive Refinement

Feedback is the principle involved in refinement. Feedback has four basic sources. The sources are: personal/self, mentor/coach, peer groups/others and supervisors. There are two types of feedback: To encourage and reinforce and to modify and correct. The latter can be unpleasant; but must be accomplished when the job being done is very critical or is detrimental to the individual. The general principle is to encourage and reinforce the positive

behavior. If this feedback is done properly the positive will, over time, supplant the negative. Cliff Wells when he was coaching basketball in Louisiana, said, “Praise 10 times for each time you criticize.”

There are many factors of feedback, as noted on Figure 2-6. It is a continuous process (real time) that involves a clear understanding of lags and the do loop shown on the figure. The do loop starts with mission/vision, then learns. Action is created from the learning. The act is then evaluated in terms of the vision providing new learning and action. The difference between the vision and current reality creates the “dynamic tension” fueling growth. The degree of follow-up is based on task complexity, consequence of failure, employee capability and the morale and development of the employee. Bob Guns lists 9 principles of feedback, shown on the figure. The bottom line is never attack the employee personally. The principles are clear without interpretation. In summary feedback is both positive (encouragement) and negative (criticism). Both are necessary; however, concentrate on the positive, eliminate the negative, as the old popular song goes.

Feedback/Follow-up

- **The right degree of follow-up should address:**

- the complexity and importance of the task,
- the consequences of failing to meet the deadline,
- the capability of the employee, and
- the morale and development of the employee.



- **Principles of Giving Feedback from “The Faster Learning Organization” by Bob Guns**

1. Be helpful, not punitive.
2. See whether the person is open to feedback.
3. Deal only with specific behavior, not generalities.
4. Deal only with behavior that can be changed.
5. Describe the behavior; don’t evaluate it.
6. Explain the impact the behavior has on you.
7. Use “I” to accept responsibility for what you’re saying.
8. Make sure what the person heard was what you intended.
9. Encourage the person to check the feedback with others.

Figure 2-6. Feedback and Followup

J. Role Modeling

Role modeling is another way people develop. When Robert Ryan first married they shared a living room with a family who had two boys. Robert would sit and loop his leg over the chair arm. Jackie would try to mimic him but his legs were too short. One day he said, “I can’t do it.” Organizations need good role models both live and in their stories. There are

many stories at MSFC of role models used, which were unsuccessful since the role of the model did not fit the personality of the one mimicking. The role models must fit the person and the organization. Countless models exist on the positive side. Observe how people will dress, speak; etc. to mimic a role model. Many role models at MSFC and all organizations are Legends that influence way beyond their active employment time. Dr. Von Braun is a great example.

K. Guidance and Control Theory

The guidance and control theory of growth is based on the principle of the guidance and control of space vehicles. The control system handles the short term disturbances by correcting the vehicle attitude against a reestablished path attitude. (Some form of optimization) Guidance is concerned with keeping the vehicle on the path to the goal (orbit). The guidance gains get tighter the closer the vehicle gets to the target. During peak disturbances guidance usually is de-emphasized and control becomes one of relieving the disturbances versus maintaining the guidance-prescribed attitude. An example is load relief control during high winds and high dynamic pressure, where the vehicle is turned into the wind to reduce loads. This load relief control introduces drift away from the ideal trajectory, thus some performance loss, in order to reduce the loads. Maintaining attitude would probably break the vehicle or result in large increases in structural weight thus reducing how much payload can be put in orbit. People should be developed, managed in the same manner. Greenleaf says, "You need enough control to maintain order, but not so much that it kills the creativity and innovation of the organization's people." Successful growth personally and organizationally requires the maximum expression of creativity of its people. [Greenleaf, 1977]

L. Communication

Two descriptions have been useful in featuring specific aspects of technical communications as applied in the design process. The first is the *T-model* and the second is *communications in the design process*.

The T-model is shown in Figure 2-7 and is so named because of the horizontal and vertical components. It is a global model that focuses key features of technical integration. It delineates the system (horizontal) along with subsystems, design functions, or disciplines (vertical) while emphasizing the importance of formal and informal integration.

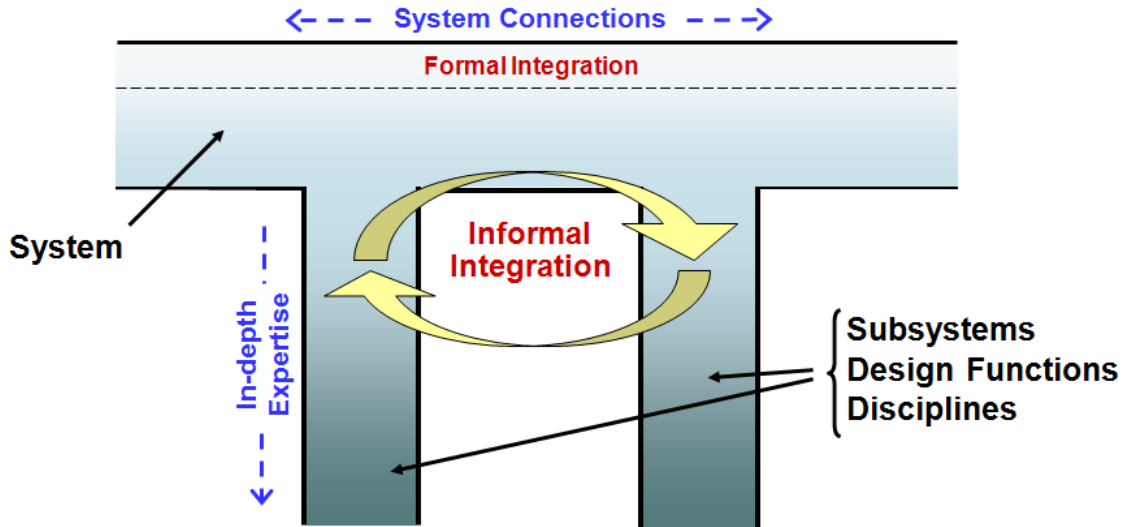

Figure 2-7. T- Model for Technical Integration

The horizontal portion of the “T” represents the System. The upper level (above the dashed line) of technical integration has been known by interchangeable names as system integration, formal integration, or top level integration. The leader and his office are the primary facilitators or operatives at this level of integration. The emphasis of this technical integration is primarily related to the systems aspects of the design process, i.e., technical management, certification of the system, etc. The primary focus is delivering the product with the proper balance of performance, cost, reliability, safety, operability, schedule, and TRL. Balance is achieved via managing and resolving conflict. All system related decisions and all system related technical conflicts are respectively made and resolved at this level. In addition, all system planning, control, and documentation is maintained at this level. Technical integration below the dashed crossbar is informal and is a key enabler for achieving a successful design. The vertical bars relate to subsystems, design functions, or discipline functions. There are a number of combinations of these (subsystems, design functions, or discipline functions) that require informal horizontal integration. The emphasis here is informal integration (communication) between and among subsystem, design function, or discipline while including the system. It can be hall-talk, phone calls, inter-office discussion, technical interchange meetings, etc. or other forms of communications. Since there are many vertical legs that affect each other, informal integration among these elements is critical. The functional organizations are the primary operatives of integration for discipline-to-discipline aspects of the design process, while the engineering design functions are the primary facilitators of integration for the subsystem-to-subsystem specific aspects of the design process. Recall, the vertical legs of the “T” also represent discipline activities (analyses, tests, simulations, etc.) associate with subsystems and design functions. They signify in-depth knowledge (in the vertical direction) but with a system perspective. This in-depth knowledge is required to be accurate and with the associated uncertainty defined.

A classical example of the T-Model is the game of basketball which is both a team and an individual emphasis sport. The vertical legs are the fundamentals of the game such as passing, shooting, dribbling, footwork, hand and finger position on the ball, screening,

blocking etc. Basketball is played with the ball being controlled with the finger tips not the cup of the hands. Footwork is first played on the ball of the feet and movement is by shifting without crossing the legs. In guarding an individual you in general don't slap down on the dribbler but slap up or to the side otherwise you get called for a foul. These are examples of informal interactions. The systems part is both formal and informal. The formal takes place by the team running patterns and then informal takes place by taking advantage and adapting to what the defense does such as the back door, or the pick and roll. The jump ball and out of bounds situation etc. are additional examples of formal activities.

Shown in Figure 2-8 is the second form of technical communication. The design process depicted in the figure is described in Lesson 4; the figure is used here to illustrate the need for extensive communication within the process. While the T-model description is global, this figure more specifically depicts technical communications as related to the compartmentalized design process. It shows the scope and variety of integrated communications needed. This can be seen by observing the interactivity among subsystems, design functions, and discipline functions; along, with their associated IxI and NxN diagrams (data flow). In addition, the V-diagram from Classical Systems Engineering indicates the need for system integration to provide discipline, planning, balancing the system design, etc. to support the design process. Furthermore, the main aspects of Safety and Mission Assurance are illustrated: Safety, Reliability, and Quality. The ultimate goal is to achieve a balanced design.

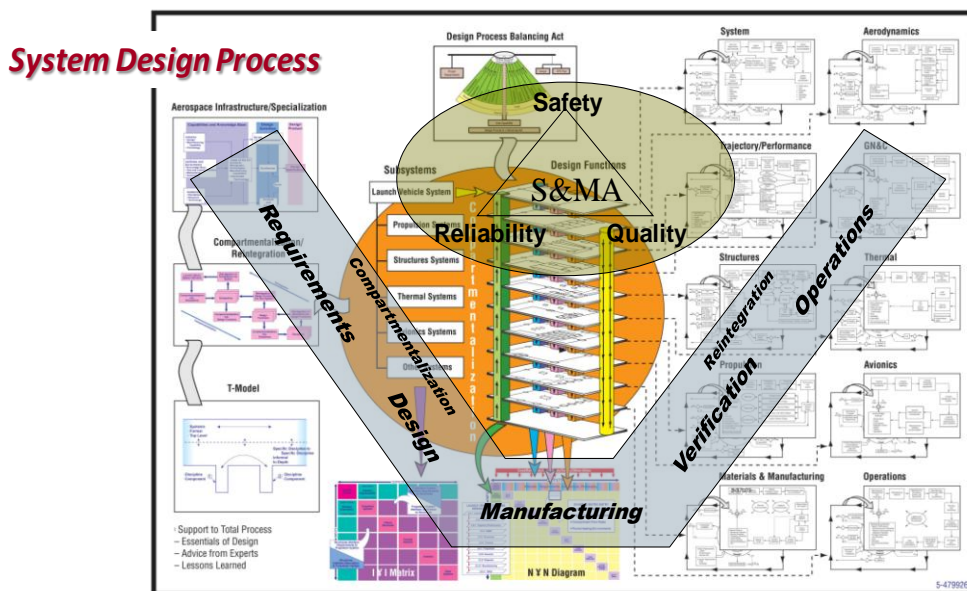

Highly interactive communication required by compartmentalized design and life cycle process.

Figure 2-8. Communications in the Design Process

✦ **A key message from Lesson 2:**

***Apply Principles Related To: Nurturing Interactive Skills
Balancing Our Roles, Needs, and Communication***

Principle II: Space Systems Are Challenging, High Performance Systems

The physics of flying into space demand that maximum energy must be extracted from the chemical energy source. This transformation from potential energy to kinetic energy must be very efficient, pushing the limits of current technology. The same is true of the structural or dry mass of the system. Here the limit is pushed by current technology to make the structure very light, but very strong. In addition losses that occur in terms of how we fly the system must be stringently managed and controlled. In other words we can just barely make orbit with the technologies available today. These factors result in a requirement for high performance systems that drive large sensitivities and unwanted interactions.

Lesson 3: Demand for High Performance Leads to High Power Densities and High Sensitivities

- ✦ ***Demand For High Performance Leads To High Sensitivities and Power Densities***
- ✦ **High performance launch vehicles are required to deliver payloads to specific orbits. To accomplish this, they must overcome gravity and attain enough velocity to achieve a stable orbit.**

☒ **Consequences:**

Systems Pushed to the Limits:

- 1. Chemical Propulsion System Efficiency**
- 2. Structural Mass Efficiency**
- 3. Losses Minimized**

☒ **Current Technology Just Barely Enables Us to Make Orbit**

Figure 3-1 shows this challenge in terms of engineering, costs, and project requirements. The physics of the problem dictates that engineering must design high power density systems, very efficient propulsion and structural systems, and manage all the losses efficiently and effectively. This must be balanced with cost and project requirements of operability etc. This results in a high risk system in comparison to all other known

transportation systems. Mission success is paramount, especially if manned flight is involved, dictating that the risks must be managed and mitigated in an effective manner. When risks are coupled with costs, this balancing the system becomes a very difficult and complex problem.

Highest Order Challenge

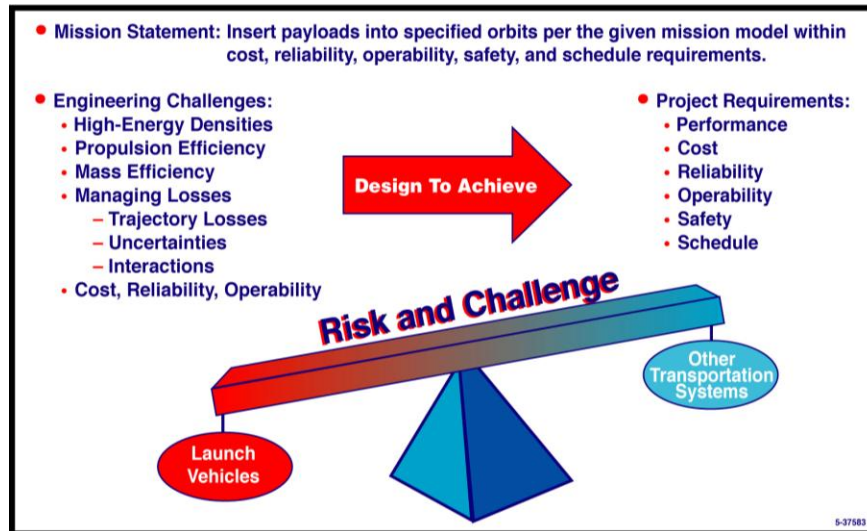

Figure 3-1. The Complexity of Managing High Risk Systems

Figure 3-2 puts the challenge in perspective by comparing the power density of common transportation engines with the Space Shuttle Main Engine (SSME). Plotted is horsepower per pound for an auto engine, Indy race car engine, small jet engine, large jet engine and the SSME. Notice that the car engine has a ratio of 0.54 while the SSME has a ratio of 879. If an average car engine was built to the same power density and efficiency as the SSME it would weigh about 1/4 of a pound. The structural efficiency required is also extreme. For example, if an aluminum Coke can was made at the same structural efficiency as the Space Shuttle External Propellant Tank, its skin would be 1/3 the thickness it is today.

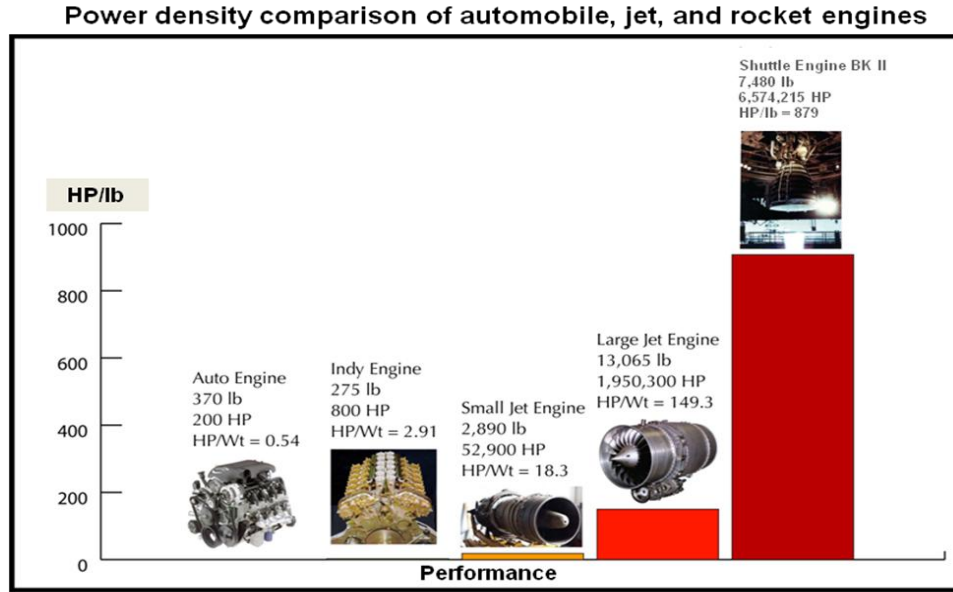
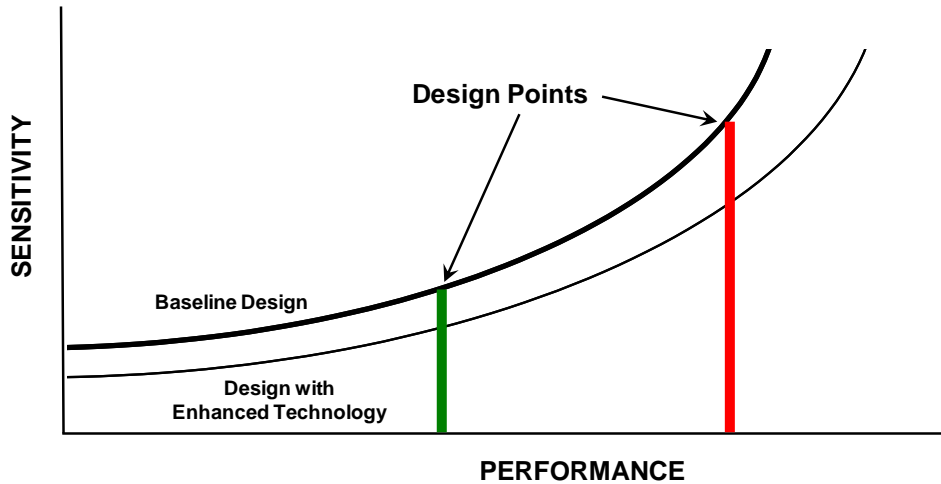

Figure 3-2. Power Density Comparison of Transportation Systems Engines

All of this high power density and high efficiency comes with a price as illustrated on Figure 3-3. This chart depicts a design principle that can be extracted from the history of space systems and says that the higher the performance requirements, the higher the sensitivity of the system to design and performance parameter uncertainties. This is a generic curve which represents a number of different physical systems. For example the structural SN Curve for fatigue is the inverse of this curve. A plot of vehicle dry weight versus dry weight margin will basically trace this generic curve. What this means then is that as we move out on the performance curve, our design, verification and operations challenges go up non-linearly with the increase in performance requirements. It means that great attention must be used to design, build, verify and operate these high performance systems. The complexity factor of these systems also makes it much more difficult to predict and understand the system induced interactions. Poole in his book, “Beyond Engineering: How Society Shapes Technology” says that the complexity factor leads to most of the failures and is very difficult to predict. [Poole, 1997] He also concludes that this results not only in a technical complexity, but in organizational complexity as well. There are many problems that occurred in the SSME that can be shown to be a direct result of the high performance requirement, which will be discussed later.

Sensitivity versus Performance



• The higher the performance requirements the greater the system sensitivity to weight, cost, parameter uncertainties, manufacturing flaws, etc.

Figure 3-3. Sensitivity Versus Performance Requirements

Figure 3-4 shows the sensitivity of a single-stage-to-orbit vehicle, where dry weight is plotted versus weight contingency in per cent. The same nonlinear trend is shown as for Figure 3-3.

Weight Contingency Sensitivity

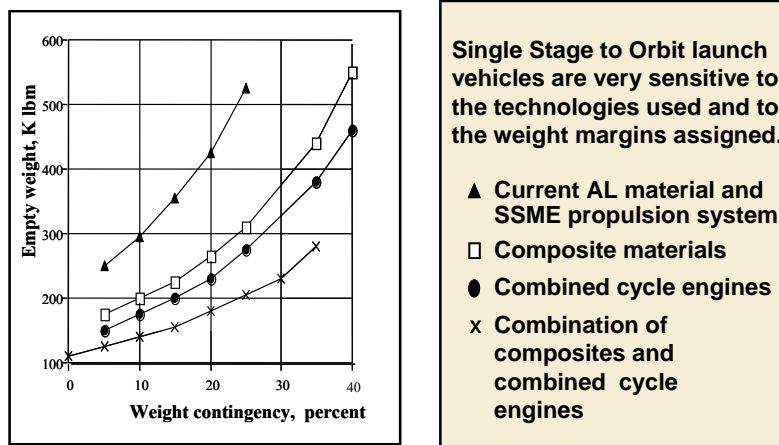

Figure 3-4. Dry Weight Versus Weight Contingency in Percent

In conclusion, high performance requirements lead to high power densities and sensitivities, which require in-depth understanding and intricate balancing of the system to achieve success.

✦ **A key message from Lesson 3:**

High Power Density Systems Require:

- ***In-depth Understanding***
- ***Intricate Balancing***

Principle III: Everything Acts As A System (Whole)

Overarching design and Technical Integration principles are summarized on the following list. They are the foundation and summary of what follows in this section, as well as in other sections.

- **Physics and other governing principles (cost, ...) rule all design activities.**
- **Everything is a System composed of complex interacting parts that have a best balanced state. Attempting to operate out of that balanced state is very costly.**
- **The best balanced state is achieved by understanding sensitivities, uncertainties and margins → leads to the quantification of risk and design confidence.**
- **Present design practice of complex systems entails compartmentalization**
 - **Subsystems, design functions, and discipline functions.**
- **Overcoming complexity and balancing the design requires Technical Integration**
 - **Interactive activity among all participants in the design process**
 - **Compartmentalized parts are designed and reintegrated into a balanced and verified product**
- **Technical Integration is enabled through formal and informal communications following the T-Model philosophy. The in-depth elements must be accurate while operating in a system role.**
- **The innovation, creativity, and decision making skills of the people form the basis for successful design.**

Embodied in these principles is the idea that while we can easily identify complex systems as a whole entity; many are composed of complicated subsystems and parts that must be designed to robustly and interactively function to support the system life cycle needs.

This section contains three lessons:

4. System Engineering and Technical Integration is the Linchpin of Project Success
5. Risk Management
6. All Design is a Paradox, a Balancing Act

Lesson 4: System Engineering and Technical Integration Is the Linchpin of Project Success

System engineering and technical integration are concerned with validity of analyses, tests, and simulations; software and hardware integration; interfaces compatibilities; interactions; validation; ... all of which are necessary for product success. Along with the basic lesson are the following corollaries:

- ✦ ***70 to 80% of all problems we encounter in design are caused by a breakdown in Systems or Technical Integration. Said differently, problems, in general, were not due to undiscovered or missing theory, but to the neglect of basic system principles.***
- ✦ ***Dick Kohrs said, "Systems Engineering is 95% communication and 5% engineering." Yet we must maintain very honed specialist skills or there is nothing of value to communicate or integrate.***
 - **Technical integration is crucial to the design process. Make every effort to encourage technical integration, and to assess that it is being done.**
 - **Communication is the key, the predominant part of technical integration.**
 - **The most effective integration communication is informal.**
 - **Understanding the physics of interactions is key to integration.**
 - **Continuously check requirements and their flow, their verification.**
 - **Continuously check assumptions.**

The above statements emphasize *basic system principles*. Yet while emphasizing the system aspects, we must maintain very honed specialist skills or there is nothing of value to integrate. These specialists are required to understand and quantify the validity of their results; in addition, to specifying the sensitivities, uncertainties, and margins associated with those results. General reference for this total section is [Blair, et. al., 2001].

An important element that overshadows the design process is Technical Integration. *Technical Integration* is an interactive activity among all members of the design community where the compartmentalized subsystem → parts are designed and then reintegrated into a balanced system design that can be verified and validated and will operate at acceptable risk. Every effort should be made to ensure that technical integration is being accomplished. As mentioned above, communication is a key factor in achieving technical integration and, as is evident, informal communication is a pervasive aspect of technical integration.

In the design of complex systems where there are high power densities, it is not only important to understand the physics but also associated interactions. In many situations the bleed off of a “slight” amount of energy can lead to instability. This is a situation where small differences can have as enormous impact. In addition, requirements can change as a result of maturing the design. Requirements, as well as, assumptions should be tracked and verified at each stage of a “design and analysis cycle” (DAC).

In order for the design process to work efficiently and take advantage of the state of the art (SOA) knowledge base, the STS must be compartmentalized into workable units after the mission and programmatic requirements are defined. The SOA information exists in three types of organizations: (1) Industry, (2) Government, and (3) Academia. The capabilities and knowledge bases of these three organizations represent the SOA and they capture standards, monographs, technologies, manufacturing processes, etc. This capability and knowledge base is a major resource for achieving successful designs where there are high power densities and extreme environments. Listed below are examples that illustrate the main points in the narrative associated with Lesson 4

- Characterization of Design Process/Technical Integration
- Shuttle First Flight Aerodynamic Anomaly

Characterization of the Design Process/Technical Integration

The purpose of this example is to provide an overview of the design process and illustrate technical integration. More detail about the design process can be found in [Blair, et. al., 2001]. The design process consists of various features and providing an explanation is analogous to “peeling an onion”. An insight will be gained of the overall process. While understanding the process, the reader should understand where she/he fits and with whom they interact. Furthermore, the illustrations represent functions that are required to achieve the design and are not to be confused with organizational charts. Finally, functions and activities associated with the design process are independent of the organization and project.

Shown in Figure 4-1 below, is the project life cycle flow. It can be seen that it starts with the Mission Statement then goes to Requirements. The design process starts with defining Architectures and proceeds through Detail Design. Then the product is built, verified, and operated. From the initial design activities through Detail Design there are a number of cycles associated with DAC and verification tests. While the life cycle process is

as shown, there are cyclic layers as the design matures; the level of design detail increases as well as the supporting data associated with analysis, test and simulations.

Principles and Characterization of Design Process

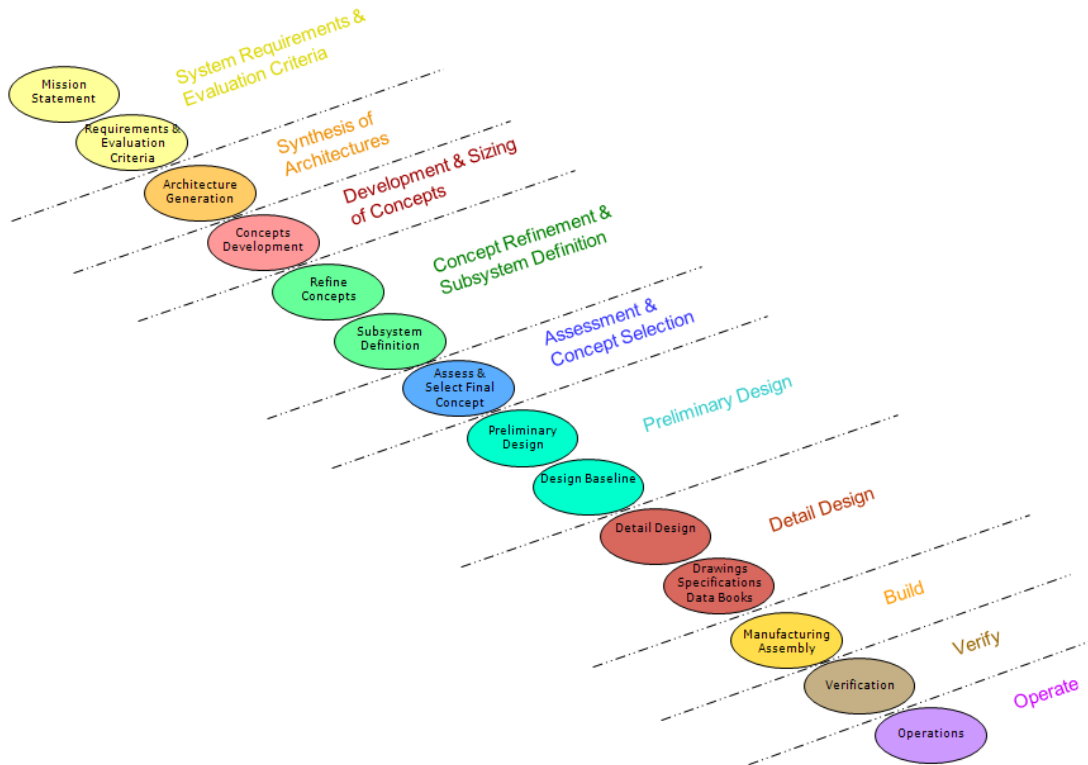

Figure 4-1. Project Life Cycle Flow

As noted in Figure 4-1, the mission statement and requirements definition precede all the design activities. Before anything can be designed, all of the requirements must be known. There have been projects in the past where the requirements were not adequately defined and the unintended consequences were significant cost over-runs. Initially, the top level requirements are defined, such as, orbit, payload definition, cost, schedule, safety, top operational requirements, etc. Then derived requirements have to be developed to fully accomplish the design of the system, subsystems, components, and parts. As the design continues requirements are continually defined, iterated, verified, and documented.

The central part of the life cycle, i.e., from Architectural Generation to and including Detail Design, is enabled by compartmentalization and reintegration, see Figure 4-2. While compartmentalization is necessary to accomplish a design, it does add complexity. The process starts with the initial launch vehicle definition and ends with the final total integrated system configuration. Firstly, the system is compartmentalized into subsystems (hardware pieces). This creates interfaces that have to be tracked via interface requirement documents (IRD) and interface control documents (ICD). Each subsystem is then compartmentalized into design functions that design the subsystem so that the attributes of the subsystem meet the derived requirements. To achieve the design, the design functions are

compartmentalized into disciplines. The disciplines provide design results determined from analysis, test and simulations.

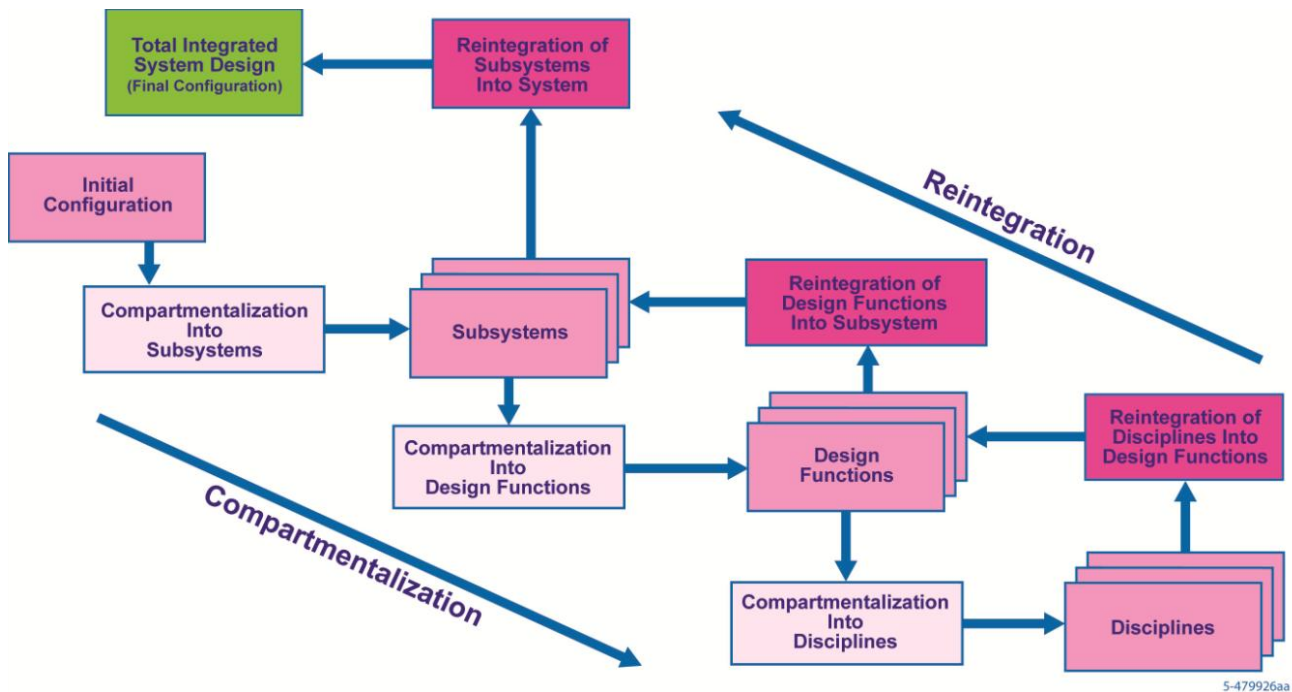

Figure 4-2. Compartmentalization and Reintegration

Thus the system is compartmentalized, now it must be reintegrated to obtain a totally integrated system design. Firstly, the disciplines are reintegrated. Adequate analyses, tests, and simulations are required to be accomplished. Then sensitivities, uncertainties, and margins need to be defined to provide information for risk assessment. Next the design functions are reintegrated. It must be assured that the attributes of the design meet the derived requirements. Furthermore, they are required to be verified. In addition, account of all interactions and nonlinearities has to be included. Finally, based on all knowledge of the design, a risk assessment is developed. This activity includes, at least, designers, disciplines, and S&MA. The final level of reintegration deals with subsystems and addresses interfaces. Specifically, the physical, functional, and informational flow across interfaces must be matched. Also interactions and nonlinearities related to the total system must be addressed. System integration and verification, operational constraints, and system risk are also considerations. A total integrated system design is achieved when compartmentalization and reintegration are completed.

Figure 4-3 provides additional insight in the compartmentalization process. The major activities and products associated with subsystems, design functions, and discipline functions are shown.

| | Subsystems (Subsystem Manager) | Design Functions (Designer) | Discipline Functions (Discipline Specialist) |
|------------|---|--|--|
| Activities | Managing all activities associated with design of the subsystem | Conceiving and designing hardware, software, & processes | Analyzing, testing, & simulating |
| Products | Hardware & Software | Specifications & drawings | Results of analyses, tests, & simulations; databooks |

Figure 4-3. Compartmentalization Elements

Further insights, i.e., “peeling the onion”, into the design process can be gained in consideration of Figure 4-4. Shown here is an illustration of subsystems and design functions. Note; requirements flow down, design attributes flow up, and interfaces are created. In the middle of the figure is an example of a system and some of its subsystems. For example, follow the solid blocks; they go from the launch vehicle system to the propellant conditioning system. Each is designed by the design functions indicated with the dashed arrows. At the top left is the system set of design functions with the top design function being the launch vehicle system plane. It is responsible for all technical aspects of the system design. That includes classical system engineering, technical integration, hardware/software integration, etc. In addition, the system design plane orchestrates and integrates the design activities. In a similar fashion the top plane for each subsystem performs a similar activity.

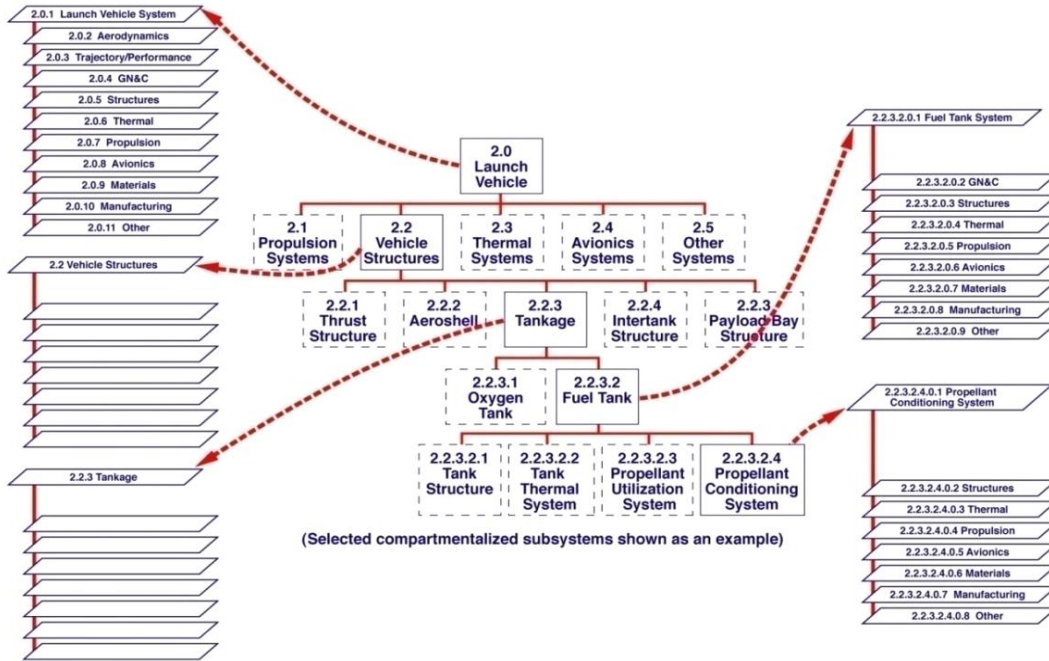

Figure 4-4. Typical Subsystems with Associated Design Functions

Technical integration of the system, design, and discipline functions are shown in Figure 4-5. The design functions are listed on the right of the figure. They provide the drawings, specifications and/or data books associated with each design function. For example, the aerodynamic design function provides the vehicle shape (outer mold line) and associated data books; trajectory/performance designs a balanced trajectory to achieve the target destination for the payload within all constraints, structures provides drawings and manufacturing specifications and so on. However, the system plane is responsible for all technical aspects of the system design. That includes classical system engineering, technical integration, hardware/software integration, etc. In addition, the system design plane orchestrates and integrates the design activities.

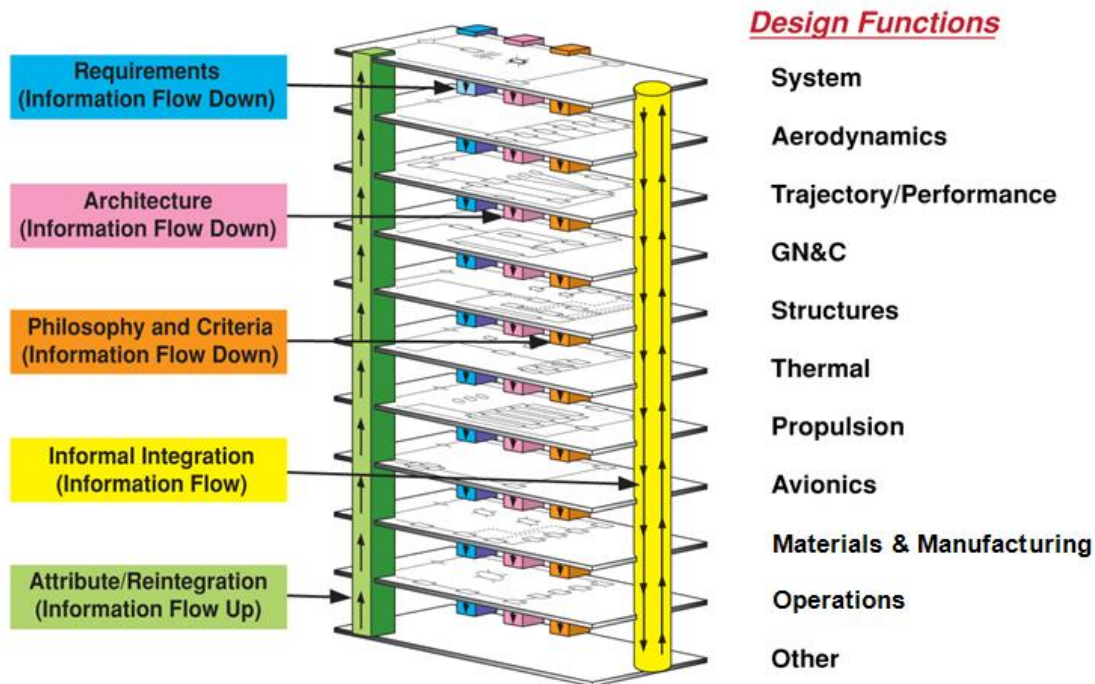

Figure 4-5. Technical Integration of System, Design, and Discipline Functions

The vertical conduits labeled requirements, architecture, and philosophy indicate formal flow of the associated information and they are controlled by the system. The system design is achieved in an iterative fashion via the design functions. Initially, a small group composed of representatives from each design function evolve a conceptual design(s) after a number of iterations. As the design matures through the DAC cycle process, the number of participants increases as well as the supporting data base. However the basic idea shown in Figure 4-5 remains in place but on a larger scale. The yellow conduit represents informal integration between the design functions and this is a key factor in achieving a balanced design. In addition, there is also significant informal integration within each design function. As the design converges, reintegration takes place and the converged attributes (green conduit) of the design formally flow to the system plane where they are eventually put under configuration control. If a balanced converged design with adequate margin can't be achieved, more iterations may be required or some system level requirements may have to be changed.

We have discussed the stack of design functions that are required to design a system or subsystem. Now consider the process that takes place within a design function (i.e., what happens on the design function planes). This is where the design functions are compartmentalized into discipline functions. As an example, consider the Structures design function shown in Figure 4-6. The block titled "Design" represents the structural designer on the CAD machine, who is responsible for taking the requirements, architecture, and philosophy from the Systems plane and synthesizing a structure that meets those requirements. In accomplishing this, he/she is supported by a number of discipline functions,

some of which are illustrated on the diagram. These include Natural Environments, Materials, Thermal, Control, Loads, and Stress. These discipline functions perform analysis, test, and simulation, and provide the necessary databases. Discipline functions also are the keepers of standards for their respective technical areas.

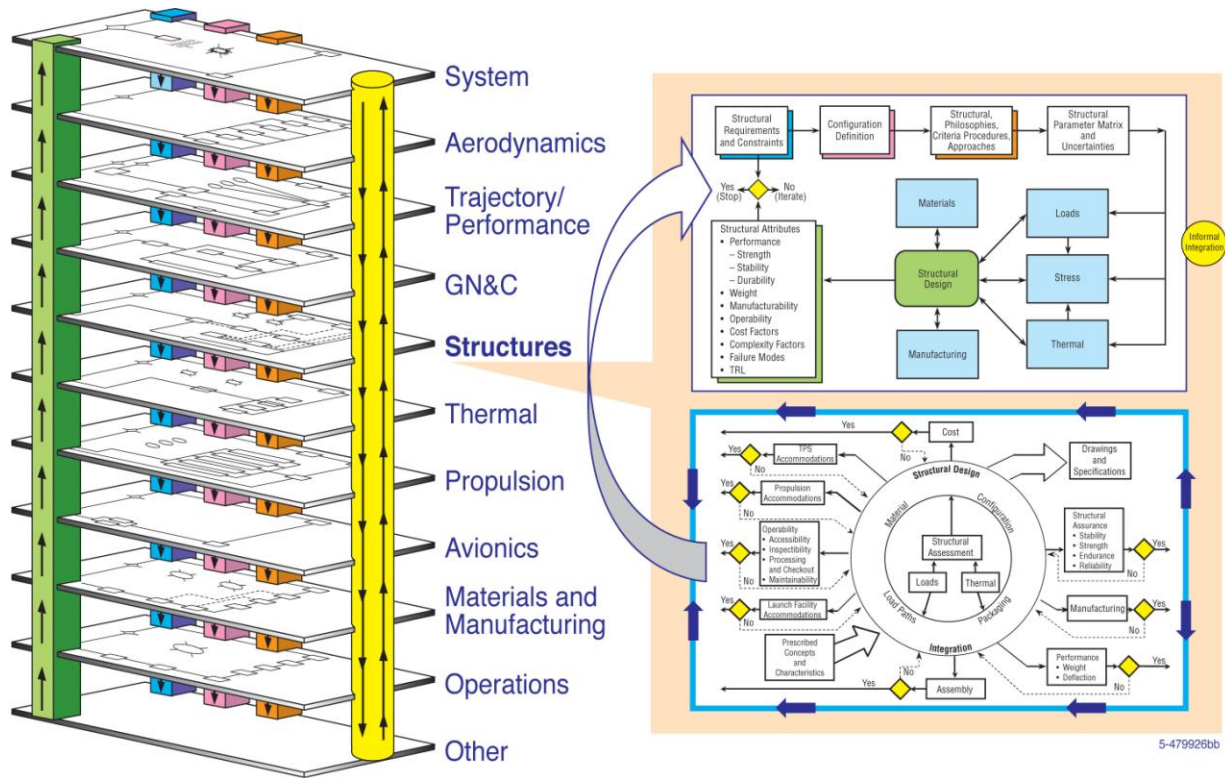

Figure 4-6. Structures Design Function with Discipline Functions and Decision Gates

The discipline functions provide the designer with information necessary to determine if the structural design will meet requirements. This is a very iterative process that requires extensive communication among the parties involved. Typically the designer hypothesizes a design (geometry, materials, etc.) from his/her experience base and imagination, informed by interactions with the discipline functions. The hypothesized design is analyzed to determine its attributes, which are compared with the requirements.

Note: The designer’s activity can be thought of as an input/output process where the independent variables are the choices made by the designer (the *design variables*) and the dependent variables are the characteristics and qualities of the resulting design (the *design attributes*).

The goal, of course, is to have the attributes match the requirements. This is shown diagrammatically as a single decision gate on the Structures design function plane. However, since there are multiple requirements to be met, there are multiple gates that must be successfully passed. Examples of these gates are shown on the diagram below the

design function plane. They include attributes such as structural strength, endurance, and weight, accommodations of propulsion and thermal protection, and manufacturing and assembly compatibility. Notice that along with these measures the gates include cost and “-ilities” such as operability. When the design has been iterated to the point that its attributes successfully pass all the gates, the Structures design function can feed the structural design and its attributes up to the System plane, and output the drawings and specifications.

This process obviously does not occur in one pass, but requires many iterations and tradeoffs. Design inherently is a balancing and tradeoff process. To arrive at an acceptable design, there are multiple tradeoffs and iterations among the discipline functions and the design functions. We will not achieve a successful design unless there is intensive interaction and communication among all the participants. Iterations may also be required with the System plane, particularly if requirements relief or reallocation is required.

These highly-connected functions and activities involve flowing a great amount of information. How is all that information managed? Input-output matrices can be useful in identifying and providing locators for information needed by the various participants. Information flow among the subsystems can be envisioned on an “I x I” matrix where the subsystems are on the matrix diagonal, outputs from a subsystem are on the horizontal of that element, and inputs to the subsystem are on the vertical. Information flow among the design functions and the discipline functions is represented on an “N x N” matrix that has a similar layout. The matrices provide placeholders to identify and locate information that is required for the integration process. In some cases, the matrix information is formally identified, for example in subsystem interface control documents and design and analysis cycle data books.

Recall that *Technical Integration* is an interactive activity among all members of the design community where the compartmentalized subsystem → parts are designed and then reintegrated into a balanced system design that can be verified and validated and will operate at acceptable risk. The Technical Integration process is represented in Figure 4-7.

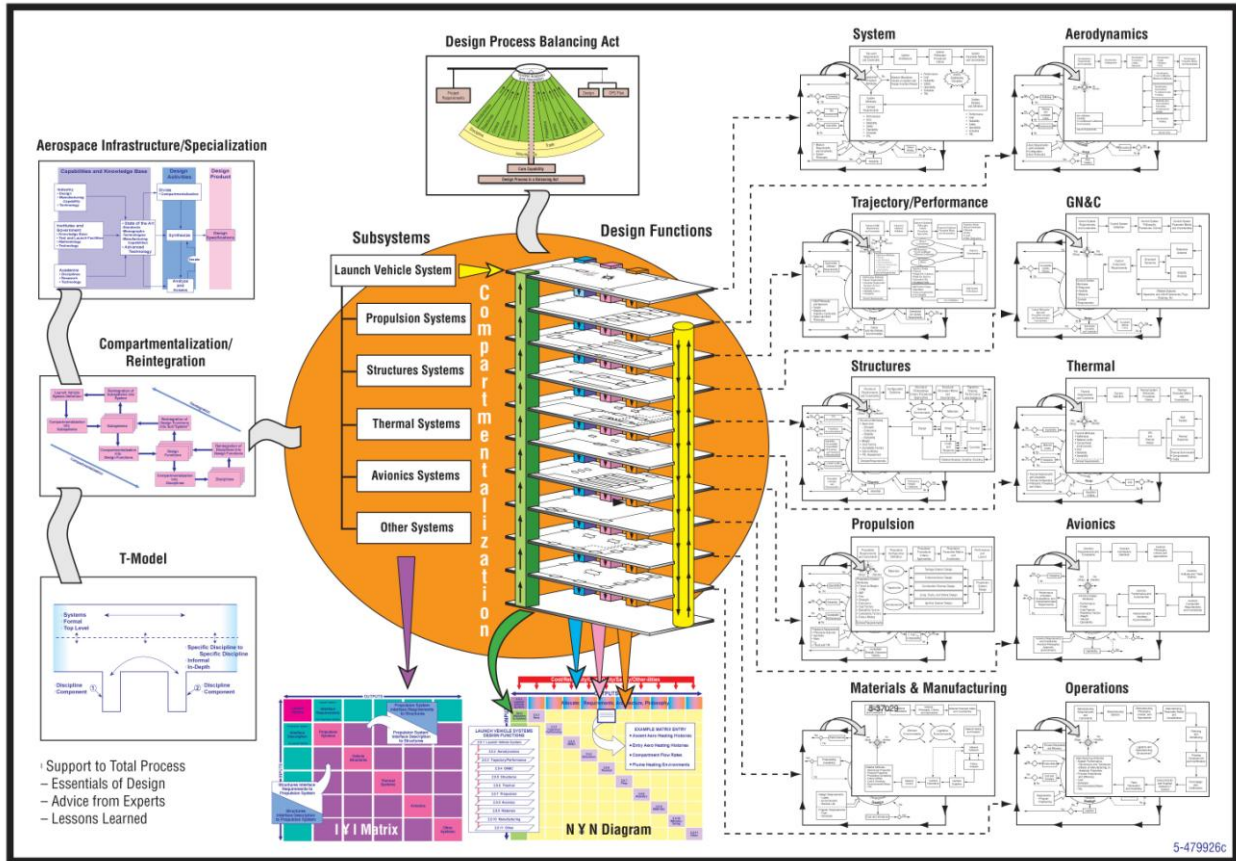

Figure 4-7. Technical Integration

There are two essential activities that overlay the Technical Integration process: Classical Systems Engineering and Safety and Mission Assurance (S&MA).

Classical Systems Engineering provides the framework, process control, and documentation for the Technical Integration process. (Figure 4-8) It is represented by the classical Systems Engineering “V” that follows the design life cycle from requirements through development and manufacturing, verification at component/subsystem level, then systems verification, certification, and operations.

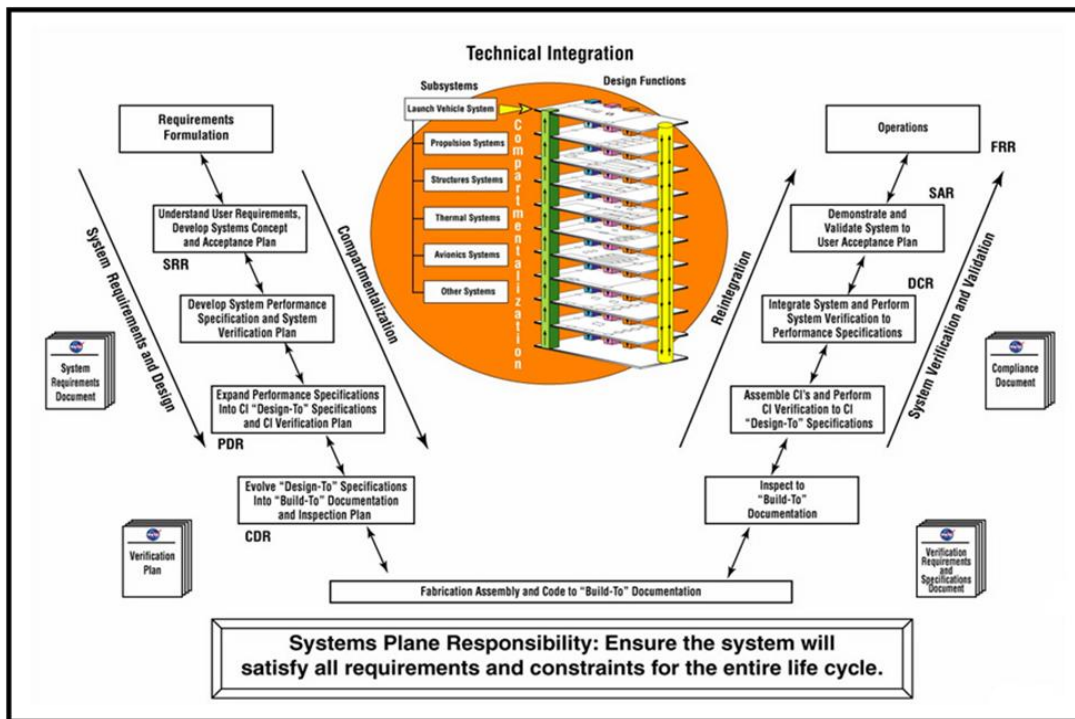

Figure 4-8. Classical Systems Engineering

Safety and Mission Assurance activities are an inherent part of the design activities. (Figure 4-9) S&MA has three main components: (1) System Safety deals with hazard identification, detection, and mitigation; (2) Reliability identifies failure modes and causes, along with their associated probabilities; (3) Quality addresses process control and verification of the as-built hardware and software.

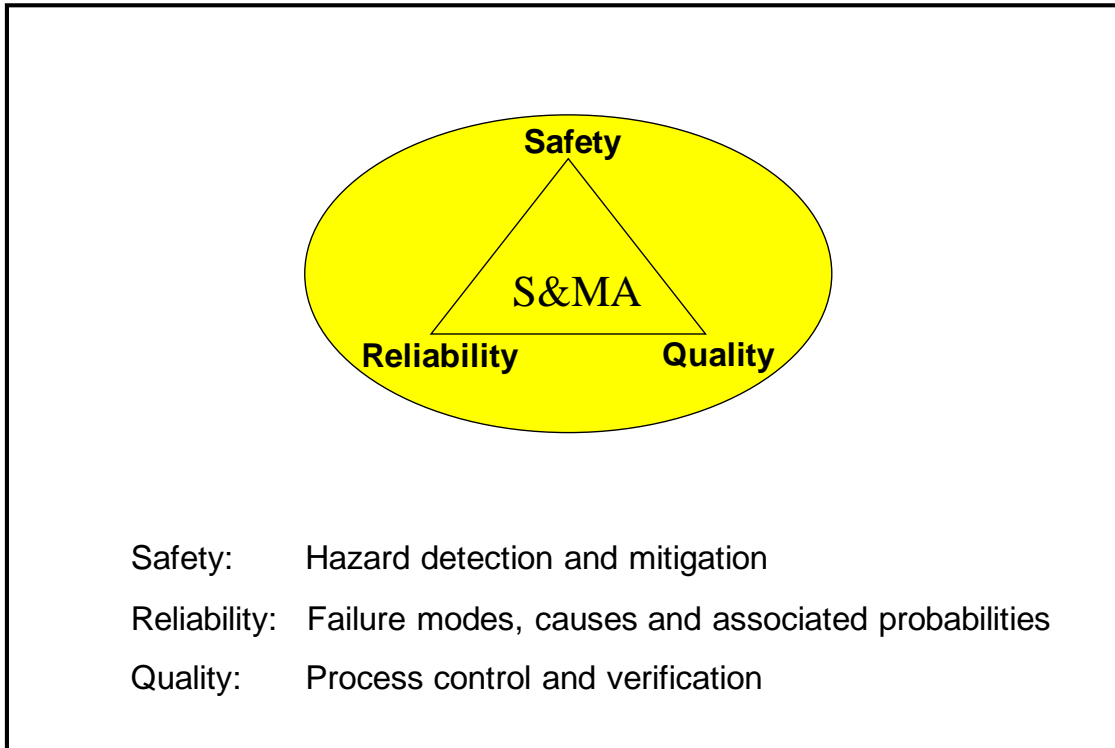

Figure 4-9. Safety and Mission Assurance

Overlaying Classical System Engineering and Safety and Mission Assurance onto the Technical Integration diagram then summarizes the Technical Execution of the Design as represented in Figure 4-10.

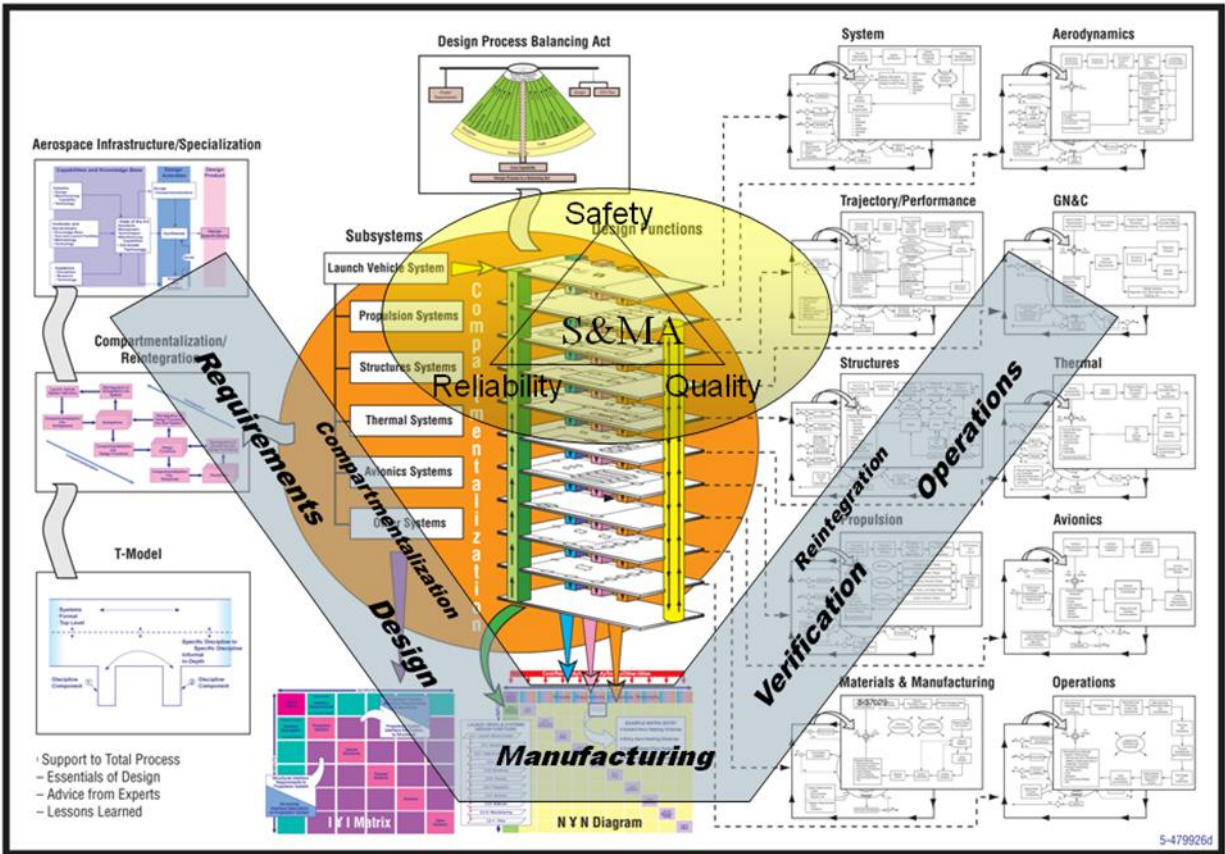

Figure 4-10. Technical Execution of Design

Achieving successful products clearly requires proper Technical Execution of Design. It also must have astute Project Management and be undergirded by the right Individual and Organizational Culture. This interactive triad of essential elements, illustrated on Figure 4-11, work together to produce products that successfully meet their objectives. These elements are addressed further in a separate report on Engineering Excellence.

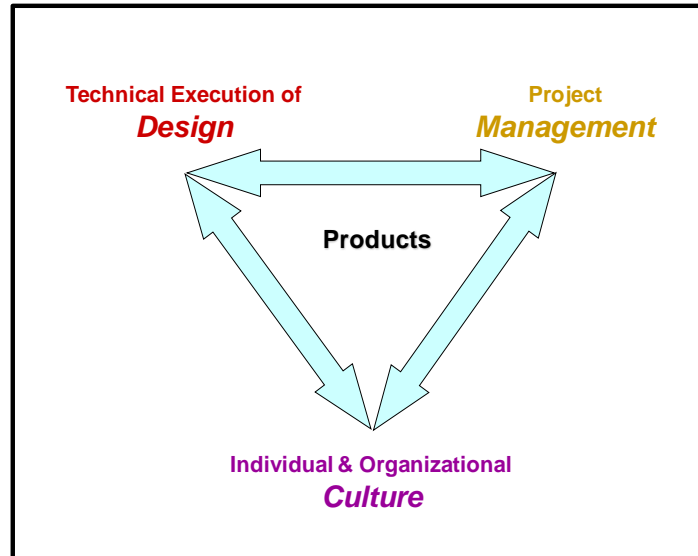

Figure 4-11. Elements of Product Success

Shuttle First Flight Aerodynamic Anomaly

The Space Shuttle is a high performance, intricately balanced launch system with complex interactions. These factors combined to generate a highly sensitive and hard to predict set of complex interactions. The first launch of shuttle STS-1 (Figure 4-12) produced several surprises.



Figure 4-12. STS-1 Space Shuttle Launch

The first was the liftoff SRM propulsion induced overpressure problem which yielded the RCS system attachment arms and produced large dynamic oscillations of the vehicle.

These phenomena will be discussed in a later lesson. The second surprise occurred during ascent when two anomalies occurred. First, the vehicle lofted significantly more than was predicted indicating that there was an unpredicted bias moment acting on the vehicle. The vehicle at SRB separation was approximately 10,000 feet higher than predicted. The second anomaly had to do with the orbiter wing loads. The trajectory had been designed to fly the vehicle conservatively at a predicted 65% of the design limit load; however, the strain gauges showed that the wing was experiencing up to 100% of the design limit load in some areas. The two effects were due to the same cause. In designing the vehicle, wind tunnel tests were required to develop the vehicles aerodynamic characteristics. In order to accomplish an adequate test, the propulsion system plumes, including the atmospheric effect on their shape, had to be simulated using a solid plume. Analytical techniques available to make the estimate of plume characteristics at that time were crude and thus gave an inaccurate answer. The plumes, in conjunction with the tunneling effect between the Orbiter wings and the External Tank and the Solid Rocket Boosters, altered the aerodynamic distribution on the Orbiter wing, creating the unpredicted moment and the increased loads on the Orbiter wings. Figure 4-13 illustrates the effect. Initially no one believed the strain gauge and aerodynamic pressure data, requiring that all the strain gauges be recalibrated. This recalibration showed that the strain gauges on the flight were accurate. Many thought that the pressure gauges were recessed too deep causing them to give inaccurate data; however after working the problem there was indeed a bias moment on the vehicle from the aerodynamic characteristics.

Space Shuttle Aerodynamics

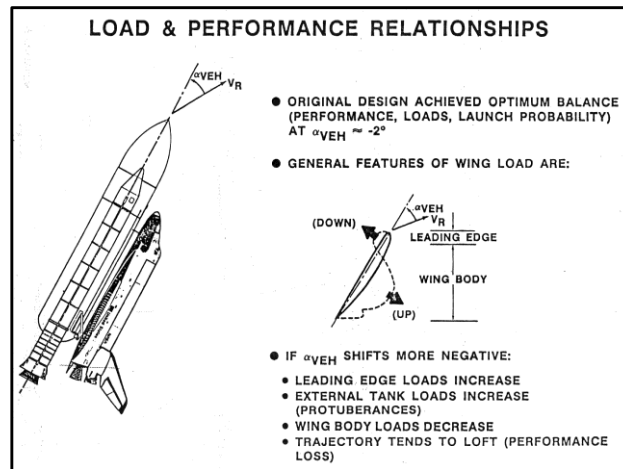

Figure 4-13. STS-1 Space Shuttle Aerodynamic Anomaly

The solution to the problem was complex. If the Orbiter wing was beefed up to handle the increased loads there would be a 5,000 pound payload loss and a schedule slip of the next launch by 2 years. An alternate fix involved flying the vehicle at a -6 degrees angle of

attack instead of the original -2 degrees at a payload penalty of 5,000 pounds. In addition the leading edge of the Orbiter wing had minor structural beef-up and the External Tank protuberances had to be requalified to the new loads. Even with these fixes the original total structural capability was not gained, requiring that a Day of Launch I-Load Update approach be added to the operational procedures to bias the trajectory to a wind profile measured 4 hours prior to launch. Figure 4-14 shows the original Q-alpha envelope and the reduced envelope that resulted from flying the vehicle in the new way. The above information is taken from presentations and notes of ASFIG meetings that the authors participated in and is summarized in [Chaffe, 1983].

Space Shuttle Aerodynamics

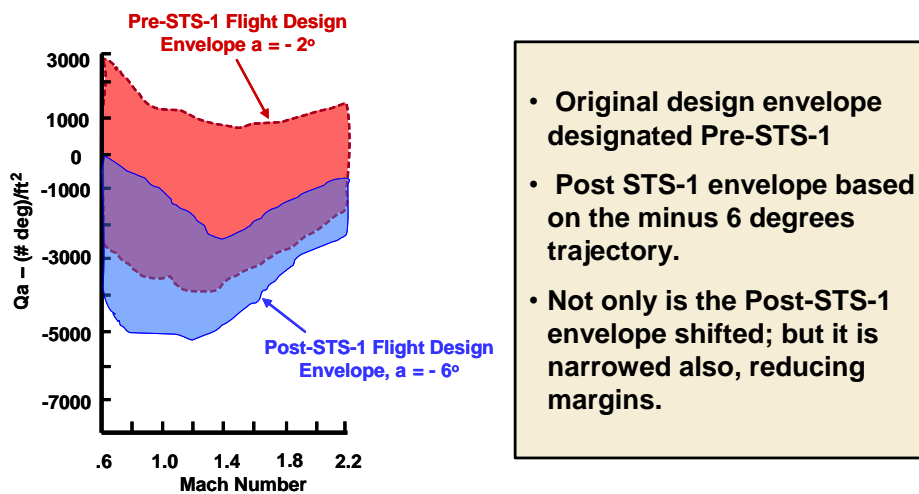

Figure 4-14. STS-1 Space Shuttle Aerodynamic Anomaly and Solution

The aerodynamic problem on the first Shuttle flight can be summarized by the following statements:

- Aerodynamic design distribution was missed as evidenced on the first Shuttle flight STS-1.
- The cause was not understanding the SRM and SSME plume effects and the base flow interaction along with the tunnel flow effects between the ET and Orbiter.
- Aerodynamics were predicted using wind tunnel test data where the plume shape and size was simulated using a solid plume.
- Sensitivity assessment using various size plume shapes would have revealed the problem.
- The Fix: Change the tilt program from -2 degrees to -6 degrees and beef-up the wing leading edge attachments and ET protuberances.
- The Cost: 5,000 pounds payload and in-flight wind constraints to launch. [Or, could have redesigned wing with 2 year schedule hit and 5,000 lbs increase in dry weight (5,000 equivalent payload loss)]

✦ A key message from Lesson 4:

Our Organizations and Products are Highly Complex Systems. Technical Integration is the linchpin of their success. Definition of sensitivities and uncertainties is a fundamental activity of the design and operations of space systems.

Lesson 5: Risk Management

✦ “Risk Management” Guides the Design with Confidence

- ✦ Risk is assessed throughout all stages of the project life cycle
- ✦ Risks are both developmental and operational
 - Technical [Safety (Personnel, Assets, and Environmental),
 - Performance (Requirements, Operations, and Supportability)],
 - Cost, And Schedule
- ✦ Methods include: Risk Matrix and PRA

One of the keys to success is assessing, understanding, and managing the various risks of the system. These risks are both technical and programmatic. The decision making process dictates that we make these decisions based on the total risks of the system. Technical risks deal essentially with potential failure modes and their probability of occurring as well as the severity of the failure. Programmatic risks of cost and schedule are similar in their approach. The technical risks also have a large impact on the programmatic risks and must include those impacts. Risk assessment and mitigation are major design activities that must be assessed throughout all stages of the project life cycle.

Risk Overview

Risk pertains to situations where there are undesirable and uncertain events that could be detrimental or have adverse consequences. In the development of space hardware, risk is concerned with the likelihood of occurrence of undesirable end states and the severity of resulting consequences. The first reference in the literature, see [Clemens, et. al., 2005], relating to the above risk definition is attributable to Blaise Pascal in 1662.

Risk assessment and management guides the design through all stages of the design process. In the end, it provides confidence in the final design. Risk *assessment* pertains to the process of identifying and modeling potential risk scenarios, determining the associated probability of a occurrence, the severity of the consequences, and actions required to reduce the risk to an acceptable level. Risk *management* is a process concerned with identifying, analyzing, planning, tracking, and controlling risk.

Concerns relating to risk occur during all stages of the design process. They pertain to technical, cost, and schedule risk. The main focuses of technical risk are *safety* (personnel, assets, and environmental) and *performance* (requirements, operations, and supportability). After a risk assessment is accepted it is usually prioritized by a project review team. The application of risk assessment and management enables the project to focus on the most pressing issues. In Figure 5-1 it can be seen that risk in one category can affect risk in other categories.

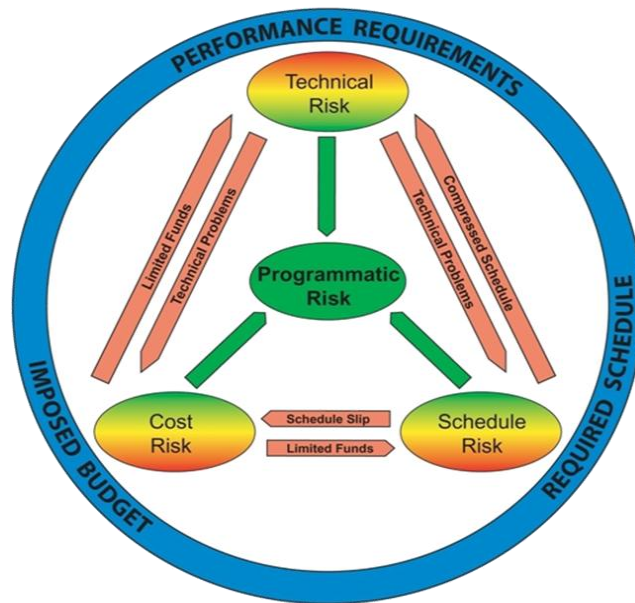

Figure 5-1 Relationships Among Risk Categories

The project's goal is to balance all risk categories and bring them to a level as low as practically possible.

Figure 5-2 provides a risk assessment taxonomy. It can be seen that there are two major legs associated with risk assessment. One method deals with risk matrix assessment and the other deals with probabilistic risk assessment (PRA).

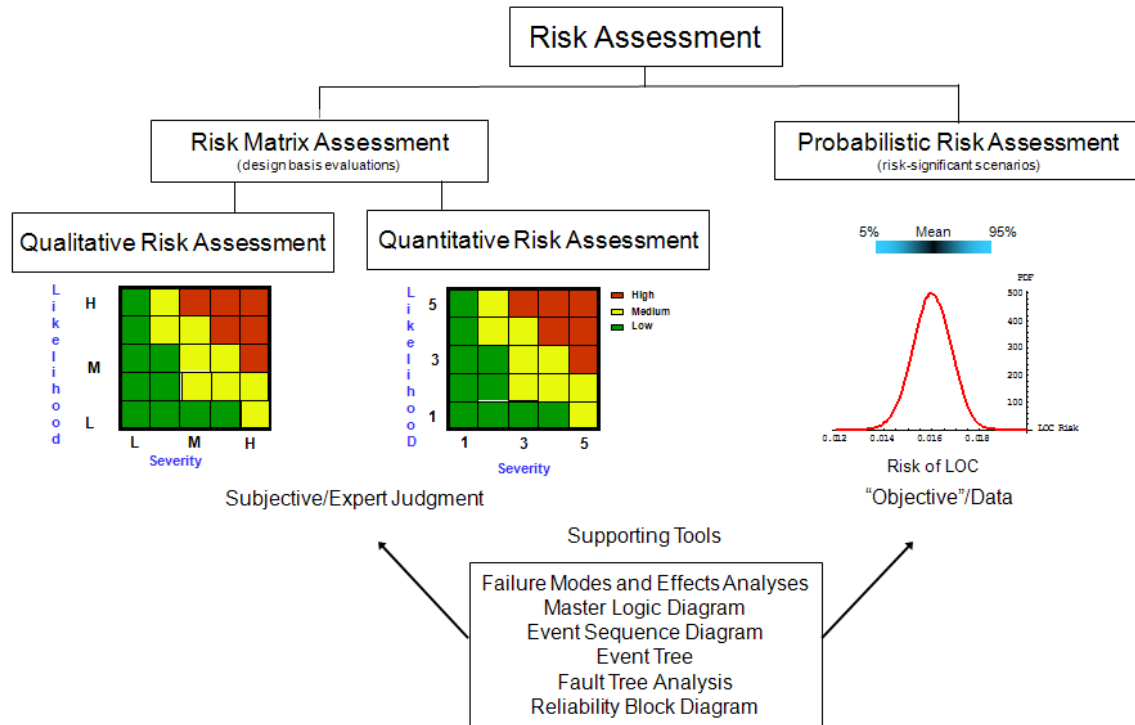

Figure 5-2. Risk Assessment Taxonomy

The risk matrix method usually applies to project levels 3, 4, and 5. The main purpose is to determine and assess undesirable events associated with technical (safety and performance), cost, and schedule and includes participation of engineering and S&MA. They determine the likelihood of an undesirable event and the corresponding severity. The risk assessment then goes to the project team where the priorities are determined. This methodology was established in the mid to late 1970's and continues to be refined to accommodate various applications.

PRA is a method that is usually applied to project levels 2, 3, and 4. This method is usually applied to assess events that have a low probability of occurrence, but with enormous consequences, for instance: loss of crew, loss of vehicle, or loss of mission. One of the distinguishing features of PRA is the determination of uncertainty associated with the risk level. As can be seen from the figure the results are represented by a probability density distribution. This methodology was developed in the early 1970's to assess risk associated with nuclear reactors. The first PRA for the Space Shuttle was completed in 1988 and the risk of loss of crew was 1/78 (current value is 1/80). In comparison the risk associated with the loss of crew of Ares-1 is 1/2000.

Examples:

- Space Shuttle SRM Ignition Overpressure
- Saturn V IU Rate Gyro Deflection

Listed above are two examples that illustrate risk. The discussion that follows will focus on these two examples.

Space Shuttle SRM Ignition Overpressure

During the ignition of a Space Shuttle solid rocket motor (SRM), the maximum rise rate of the internal total pressure is about 9000 psi/sec. When the SRM hot exhaust products (mass of exhaust gas) is suddenly injected (it takes ~ 0.5 seconds to reach a total mass flow of ~12,000 lbs/sec) into the confined volume of the Shuttle Mobile Launcher Platform (MLP), main deflector, exhaust trench and side deflector elements it produces an “overpressure wave” that is propagated back to the launch vehicle approximately as a hemispherical, high amplitude wave. The result is a transient high amplitude pressure distribution that vibrates the vehicle system.

Titan III flight tests about 1975 indicated high ignition overpressure (IOP) levels. In addition, tests at Marshall Space Flight Center Acoustic Model Test Facility also indicated high IOP levels; see [Jones, et. al., 1994]. Structural analysis indicated the response was acceptable and a decision was made to fly STS-1 as is and to assess IOP effects after the first flight. On STS-1, there was a high amplitude overpressure wave that was developed that resulted in vibration responses on the Orbiter’s wing, body flap, vertical tail, and crew cabin that exceeded predictions. In addition, struts on the Orbiter’s reaction control system’s oxidizer tank were buckled.

The first Space Shuttle flight was in April 1981 and the second flight was in November 1981. During this time an extensive effort was initiated not only to devise a means for abating the IOP but also implementing a design fix on the Space Shuttle MLP at KSC. During that period, 40 tests using a 6.4% Shuttle model, see Figure 5-3, were conducted and a design fix was established. Two types of fixes were finalized and these were used to reduce the IOP levels. One consisted of a water spray nozzle system where the water sprays were directed towards the SRB at two axial positions under each SRB for a total water discharge of 100,000 gpm for each SRB. Six nozzles were positioned ~ 22 inches below the SRM and two other nozzles were 140 inches below the SRB. These sprays function to provide a substantial mixing of the water with the SRM exhaust mass flow so as attenuate the IOP wave. The effectiveness of the water injection alone is shown in Figure 5-4. The second fix was a set of 12 inches deep water troughs that were placed completely across the large drift holes and they were filled with water. This fix was designed to act as barriers to block any reflected waves that developed below the MLP, see [Jones, et. al., 1994]. Figure 5-5 shows both the water spray and water trough fixes.



Figure 5-3. Acoustic Model Test Facility - 6.4% Shuttle Model

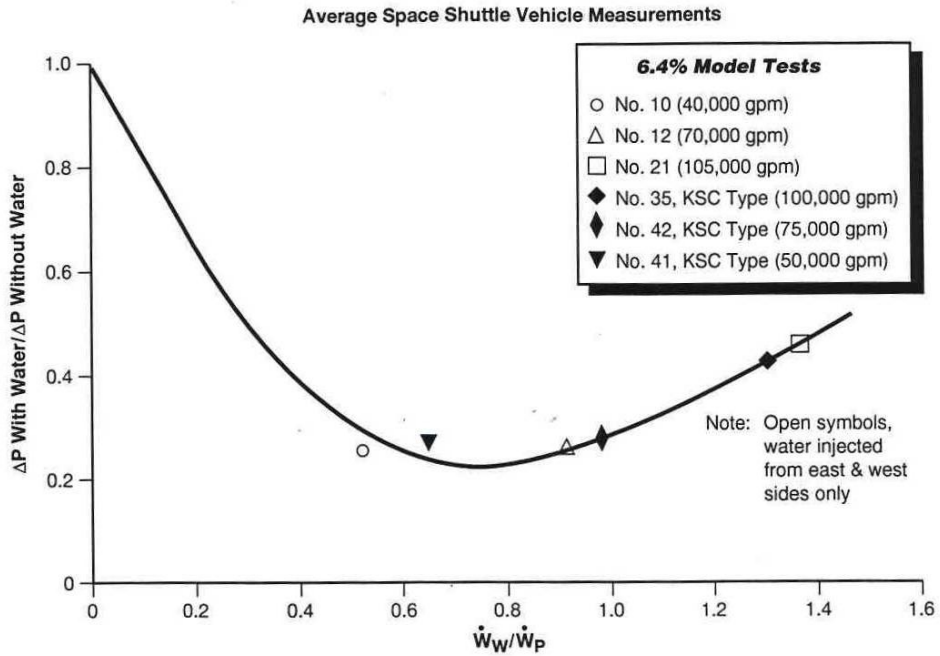

Figure 5-4. Effect of Water in Primary Side of SRB Hole on Positive Peak Overpressure

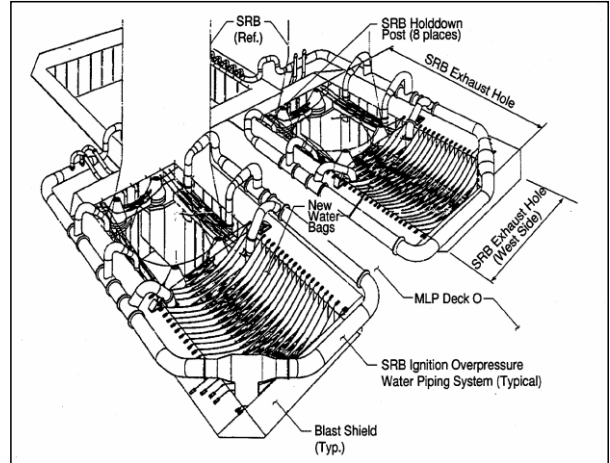

Figure 5-5. Water Spray System and MLP Water Troughs

The IOP suppression fix described above was implemented on STS-2 and all subsequent Shuttle flights. Figure 5-6 shows the comparison of the overpressure waveform at the Orbiter Base Heat Shield between STS-2 (with) and STS-1 (without) the IOP suppression fix.

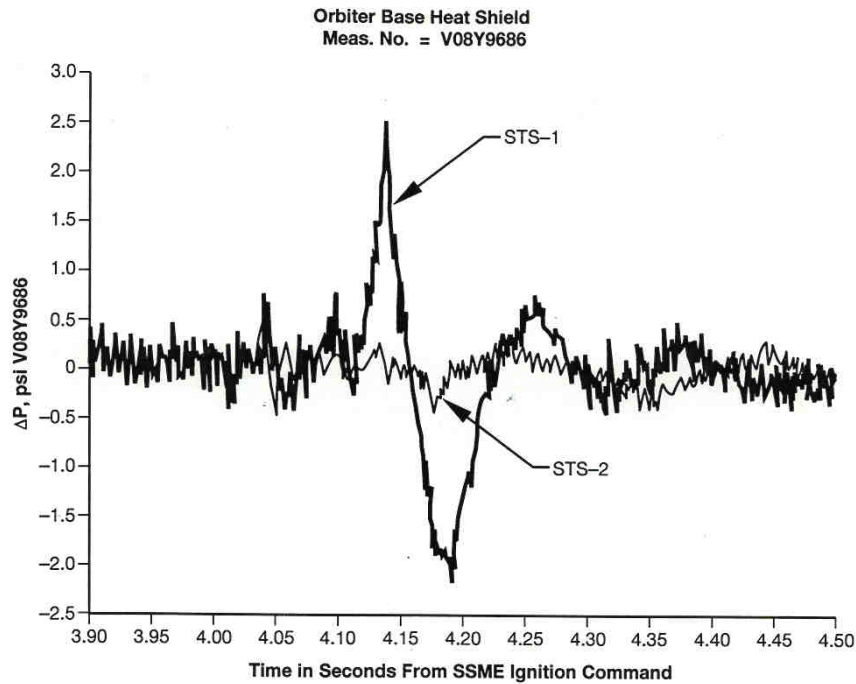

Figure 5-6. Comparison of the Overpressure Wave at the Orbiter Base Heat Shield Without Suppression (STS-1) and With Suppression (STS-2)

Also, shown in Figure 5-7 below, is the SRB IOP peak amplitude data indicating the effect of the fixes. This figure indicates the trend in the data, i.e., approximate mean values.

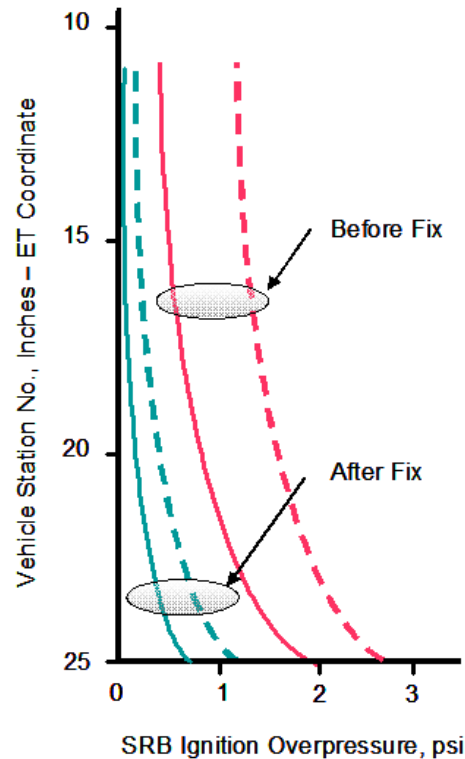

Figure 5-7. SRB Ignition Overpressure

In the figure there are two sets of data. One set pertains to IOP levels before the fix and the other set is after the fix. It can be seen that the maximum level on the Space Shuttle External Tank before the fix was about 2.0 psi. In the model test the levels were higher. These levels were higher because the solid rocket motor used in the model test was not an exact scale of the SRB and because of the scaling factors used. However, in the tests after the fix, the data indicates levels that would not seriously impact the vehicle loads. Also, the flight data after the fix substantiates the findings that the fixes would abate the IOP and it would no longer impact vehicle loads.

This is an example where the risk in the system was not correctly judged and had to be addressed after the first flight.

Saturn V IU Rate Gyro Deflection

During the development of Saturn/Apollo there were unknowns regarding the ability to model the dynamics associated with bending, controls, loads, aeroelasticity, etc. This resulted in risk regarding flight uncertainty. The design team recommended to the project office that a ground vibration test (GVT) be conducted to determine various unknowns and uncertainties to anchor the models. The project accepted the recommendation and a GVT was conducted. This test series uncovered a large deflection in the instrument unit (IU) at the location of a rate gyro.

In Figure 5-8 the instrument can be seen on the Saturn/Apollo along with approximate locations of rate gyros. It turned out that the load path of the Service Module (SM) and Lunar Module (LM) went through the forward portion of the Instrument Unit (IU) through the location of the rate gyro at the first bending mode frequency. The consequence of this situation was that as the vehicle flew a bending vibration sensed by the rate gyro would be sent to the control system and could couple in such a way that the vehicle would be dynamically unstable. [Ryan, et. al., TM-78037, 1980]

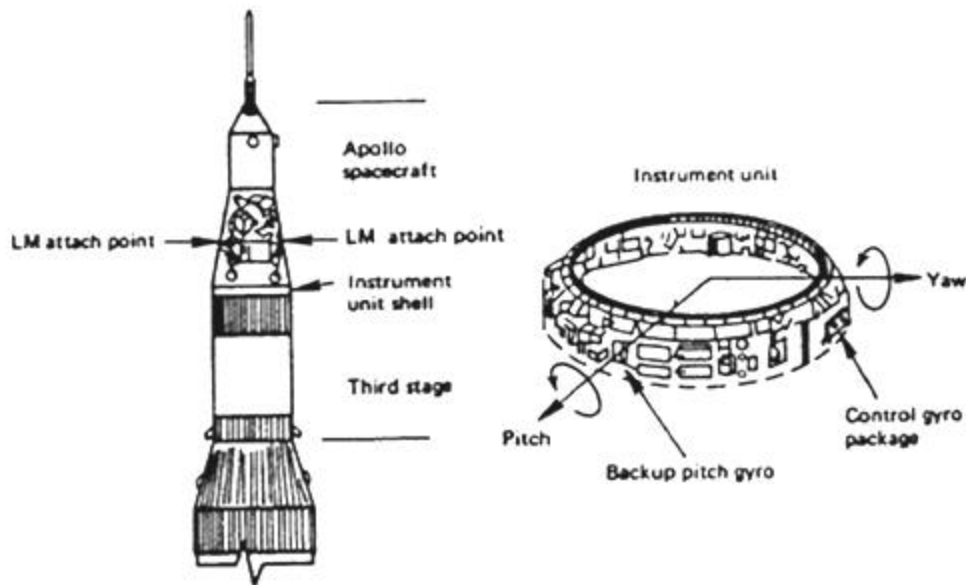

Figure 5-8. Saturn/Apollo – Instrument Unit

In Figure 5-9 is a schematic of a control rate gyro that shows its location along with an exaggerated view of the deflection. Also, the LM attach point (load path) can be seen with the control gyro located below it. In the deflected position shown, the control system would indicate that the vehicle was at an angle of attack as indicated when in fact it would not be at the sensed angle of attack. In addition, it would indicate that the vehicle would be vibrating as a rigid body at the bending frequency. The rate gyro was moved to a more benign location that reduced this effect by a factor of three and potential problem was eliminated.

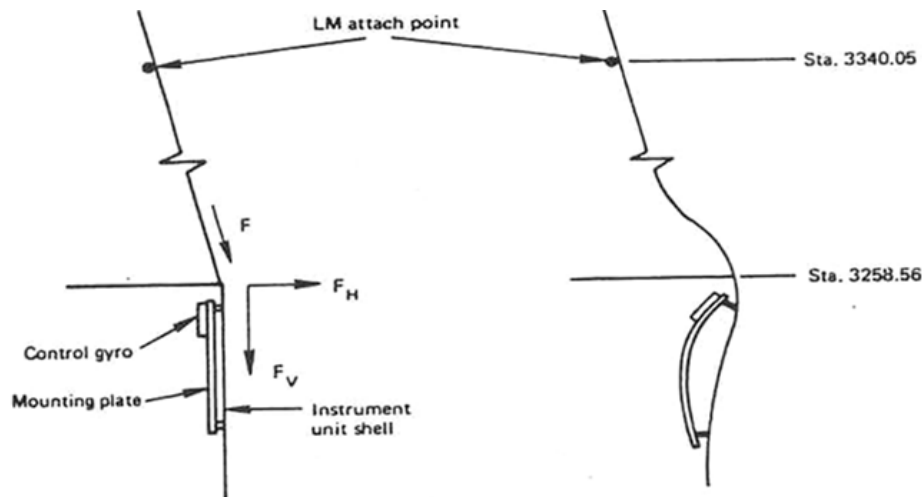

Figure 5-9. Schematic of Gyro Mounting and Local Deformation

This is an example where the risk was assessed and appropriate action was to reduce it to a level as low as possible, i.e., benign state.

From these examples it can be seen that risk must be continually assessed and managed throughout the project life cycle. Analysis and careful testing with all conditions simulated is best for quantifying risk; however, there can be “unknown unknowns.” In that case, the unknown events should be *anticipated!* In many in-flight anomalies, there were usually indicators pointing to potential problems.

✦ **A key message from Lesson 5:**

Risk must be continually assessed and managed throughout the project life cycle

Lesson 6: All Design is a Paradox, a Balancing Act

✦ ***All design is a paradox, a balancing act. Because of conflicting requirements, you must take some of what you don't want, to get some of what you do want.***

✦ **All designs must achieve acceptable reliability for safety.**

✦ **Within this constraint, balancing must occur:**

- **Among design and discipline functions (energy redistribution).**
- **Among program requirements, the design, manufacturing, and operation plans.**
- **Problems not cured in design must be compensated for in operational compromises and constraints (e.g. may lead to reduced probability of launch).**

- **Among cost, schedule, and performance, with associated risks.**
- **The above attributes are linked; an improvement in one attribute typically produces a detriment in another.**
- **The balancing act requires open communication and key decision judgments.**

Lesson 6 deals with balancing the system among its set of conflicting requirements and performance metrics. We accomplish design in terms of the requirements/constraints using trade studies. Trade studies drive out the differences in design alternatives and illustrate the strongly coupled nature of space systems. Sensitivities are the guiding light for accomplishing trade studies. How well we accomplish this balancing act using trade studies determines product success. David Pye says,

“Any of these forms of energy is capable of producing changes, changes in things; more exactly, redistribution of matter... Now whenever a change is made by passage of energy and a result is left, this event takes place in a group of things. Things are always together. They do not exist separately... All you can do, and that only within limits, is to regulate the amounts of the various changes. This you do by design.”

“The requirements for design conflict and cannot be reconciled. All design for devices are in some degree failure. The designer or his client has to choose to what degree and where the failures shall be.”

“You must take some of what you don’t want in order to get some of what you do want.” [Pye, 1969]

Thus, design is paradoxical. As a consequence, we balance the system to the degree possible among conflicting requirements. Because of the demanding, high-performance nature of launch systems, this balancing act associated with their design is especially challenging. Balancing must occur within the performance attributes of the system, and there must be balancing among technical performance attributes, the -ilities, and the programmatic attributes of cost and schedule. There can be tradeoffs between payload delivery capability, vehicle robustness, launch probability, and operational complexity. Problems that can’t be cured in design must be compensated for in operational compromises and constraints. Knowledge of system risks is necessary to make correct tradeoff and balance decisions. The balancing act requires open communication and key decision judgments.

Tradeoffs are made at essentially every level to achieve the desired balance. An example of performance based trade studies is shown in Figure 6-1. Each of the design functions shown has options that can be explored to meet its requirements, and can be traded within its own area. There are also trades among the design functions, as well as trades with the total system. An actual trade space would have many more options than just the few illustrated here.

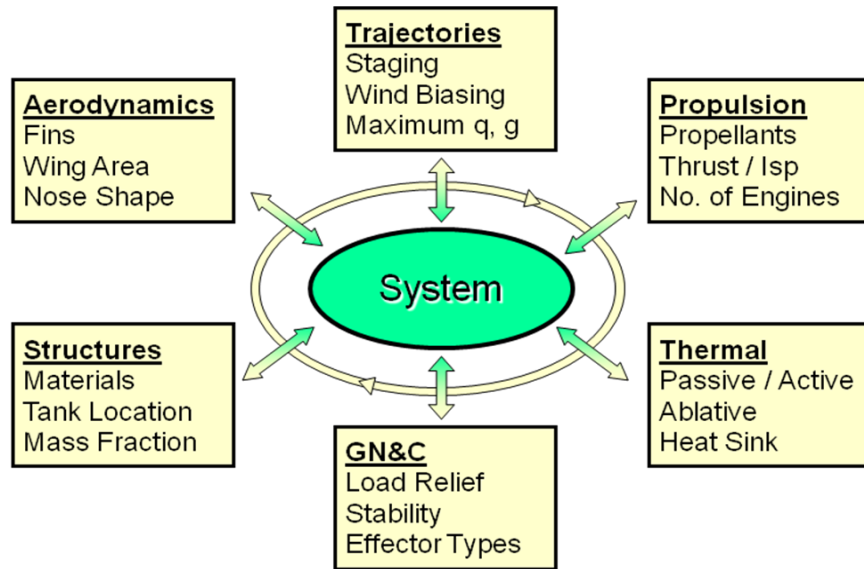

Figure 6-1. Example of Performance Based Trade Studies

Figure 6-2 illustrates the fact that the design process is a balancing act, seeking the best design balance point among all the many interacting elements. Balancing must occur among all technical and programmatic aspects of the project.

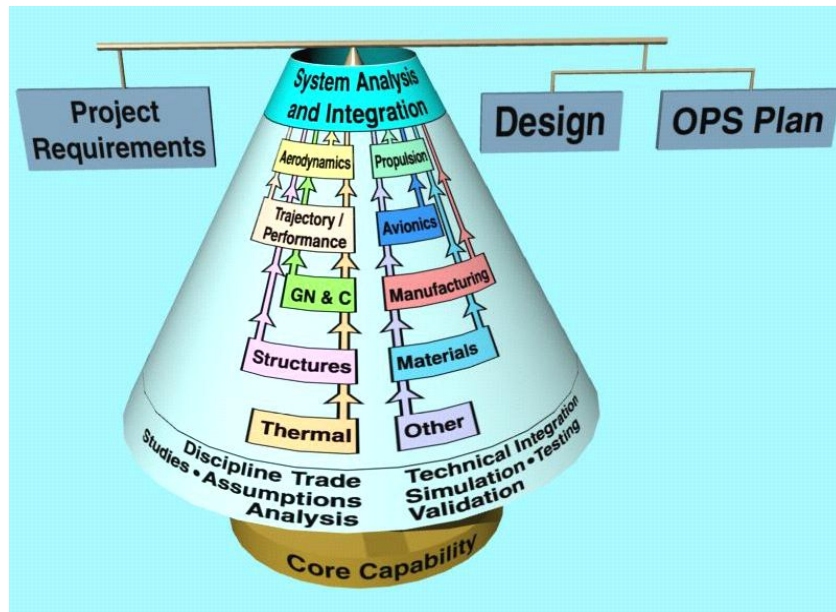

Figure 6-2. Design Process Balancing Act

Examples:

- Balancing Payload Performance, Trajectory, Control, Loads, Thermal
- Load Relief / Performance Trades
- Wind Biasing
- Saturn V Load Relief Trade
- Operations versus Vehicle Performance
- Solid Rocket Booster Water Impact / Recovery

Balancing Payload Performance, Trajectory, Control, Loads, Thermal

For the ascent phase of flight, there are a number of flight mechanics parameters that must be traded to achieve the best balance of payload mass to orbit, launch availability, operational complexity, and system robustness. They include trajectory, control, loads, and thermal environment (Figure 6-3). The basic trajectory is determined to maximize payload mass delivered to orbit. The control system orients the vehicle to follow the optimal trajectory. The more closely the vehicle can be controlled to the optimal trajectory, the more payload mass can be delivered to orbit from a flight-mechanics viewpoint. However, when the vehicle encounters winds, holding tightly to the optimal trajectory causes the aerodynamic loads to be relatively high. Higher aerodynamic loads require stronger, heavier structure, which reduces the payload mass delivery capability. We can relieve the wind-induced aerodynamic loads by turning the vehicle to reduce the angle of attack; however, this causes the trajectory to deviate from optimal. So there is a tradeoff required—a balancing act. Thermal environments can be affected by the flight path during the latter part of atmospheric ascent, so those considerations are also part of the balancing.

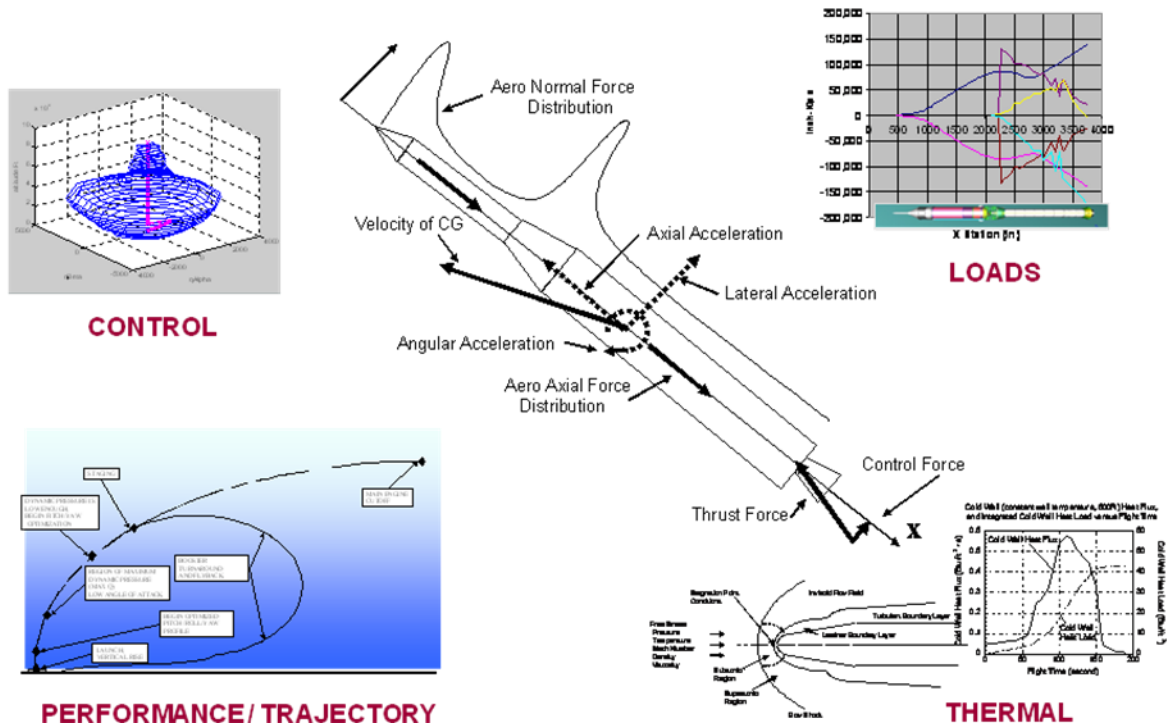

Figure 6-3. Balance Performance, Trajectory, Control, Loads, Thermal

One of the most highly tuned and balanced systems is the Space Shuttle. The Shuttle is a stage-and-a-half configuration with a winged, reusable Orbiter. This means that it is extremely sensitive and must be reevaluated after any change, however small. It must “thread the needle” through its many tight constraints. As a consequence, it is operationally expensive, requiring much continuing attention. [Chaffe, 1983]

Load Relief / Performance Trades

Typically, the best balanced system involves reducing the wind-induced aerodynamic loads to allow a lighter structure. There are three techniques commonly used to reduce these loads: wind biasing, load relief control, and modal suppression. Figure 6-4 summarizes the benefits and costs/disadvantages for each technique.

| Method | Benefits | Costs/Disadvantages |
|---------------------|---|---|
| Wind Biasing | Lower rigid-body loads, thus lighter structure or more margin; Lower performance variations | Operational complexity and cost |
| Load Relief Control | Lower rigid-body loads, thus lighter structure or more margin | Path-deviation performance losses; Control system complexity; Added failure modes |
| Modal Suppression | Lower flex-body loads on forward section of vehicle, thus lighter structure or more margin | Control system complexity; Ground vibration tests for required modal accuracy |

Good vehicle design chooses the best balance of these options, considering benefits, costs, risks, and robustness.

Figure 6-4. Comparison of Load Reduction Methods

For wind biasing, the ascent trajectory/guidance profile is biased for an expected value of winds occurring over a specified time period (e.g., a month). If that expected wind were actually experienced during flight, there would be no wind-induced load on the vehicle. Of course, the actual wind always differs from the expected or predicted wind, so there will be wind loads caused by the difference between the actual and expected (biased) winds. Wind biasing allows the structure to be designed to withstand only the deviations from the expected wind, instead of the full range of winds possible for that time period. The disadvantage of wind biasing is operational complexity and cost. There will be more discussion of wind biasing later.

Configuring the control system to sense and reduce the wind-induced aerodynamic load is designated “load relief control”. Although controlling the vehicle to reduce the aerodynamic load generally entails deviating from the payload-optimized trajectory, using load relief control provides the most favorable net payload capability for many vehicle designs. However, it entails the addition of lateral accelerometer sensors and filtering, which adds failure modes and operational complexity.

Modal suppression is the use of the control system to actively damp some vibrational modes to reduce loads caused by modal tuning with wind gusts. This can reduce the loads on the forward section of flexible vehicles, thus allowing lighter structure or more margin. However, there is some system complexity introduced, and active modal control requires accurate knowledge of modal characteristics, which may entail ground vibration tests of the structure.

Good vehicle design chooses the best balance of these options, considering benefits, costs, risks, and robustness.

Wind Biasing

As discussed earlier, wind biasing is a means of relieving loads during ascent. The choice of what wind-biasing time period to use for design is a tradeoff decision. See Figure 6-5. For example, we can design for the expected (average) wind over a yearly, monthly, or daily (several hours) time period. In each case, the trajectory/guidance profile must be generated and loaded into the flight computer. Designing for a yearly wind bias would allow one profile to be used regardless of when the launch occurs during the year. This is operationally simple, but requires a strong vehicle, since the actual wind varies greatly during the year from the average annual wind. A monthly bias requires loading a profile for the specific month of launch, but reduces the design loads because wind variations within a month are smaller than within a year. Carrying the concept further, we can measure the wind on the day of launch and bias to that wind. Now the variability is much smaller, so the wind loads are reduced to those corresponding to only the wind variability within a few hours. The structure can then be lighter, but now there is a significant operational cost incurred on every flight, because on the day of launch the winds must be measured, the profiles must be generated, independently verified, and loaded into the flight computer. So a tradeoff decision is required. (Further details of day-of-launch biasing are given in Lesson 17.)

If one designs for wind biasing for a given time period, the vehicle will have to operate with biasing for that period or a shorter period. One approach is to design for a monthly mean, for example, and hold in reserve the possibility of operating with day-of-launch biasing. This retains margin that can be used to accommodate downstream payload performance problems, increase launch probability, or provide mission flexibility. Figure 6-5 illustrates this concept.

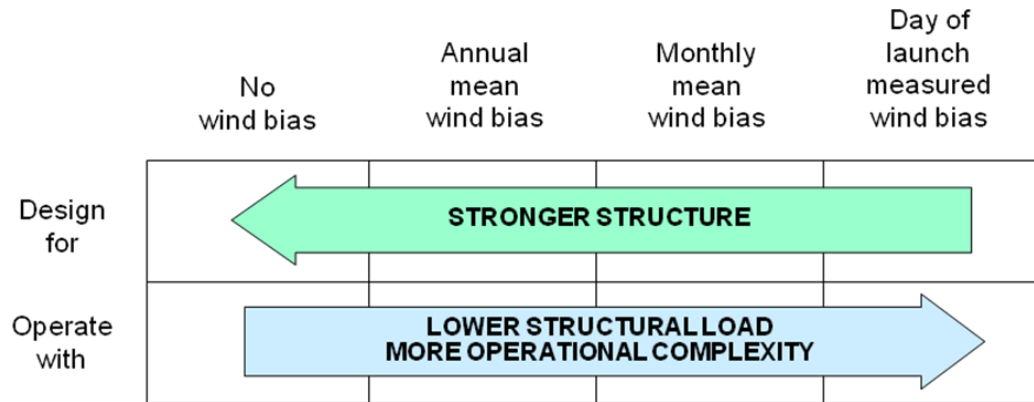

- Operating with day of launch bias gives minimum structural load.
- A spread between “Design for” and “Operate with” provides margin that can be traded for payload performance and/or launch probability.

Figure 6-5. Wind Biasing Options and Effects

The approaches taken for Saturn V and Shuttle are illustrated on Figure 6-6. Saturn V was designed for no wind biasing, so it had a very strong structure. It was operated with monthly mean wind biasing, so there was margin provided by the difference between the “Design for” and the “Operate with” points. This margin in structural capability, along with margin in the propulsion system, provided mission flexibility that enabled carrying the Lunar Rover and launching Skylab, two applications that were not envisioned in the initial design.

Space Shuttle followed a different path. Being a stage-and-a-half vehicle, it required a relatively more efficient (lighter-weight) structure than did the three-stage Saturn vehicle. The initial intent was to design for monthly mean wind biasing. However, the effects of the unexpected first flight aerodynamic anomaly discussed in Lesson 4 meant that the as-built vehicle was not as strong as initially intended, and required day-of-launch wind biasing. Since there is no spread between the as-built point and the operate point, there is no margin benefit for Shuttle as was the case for Saturn.

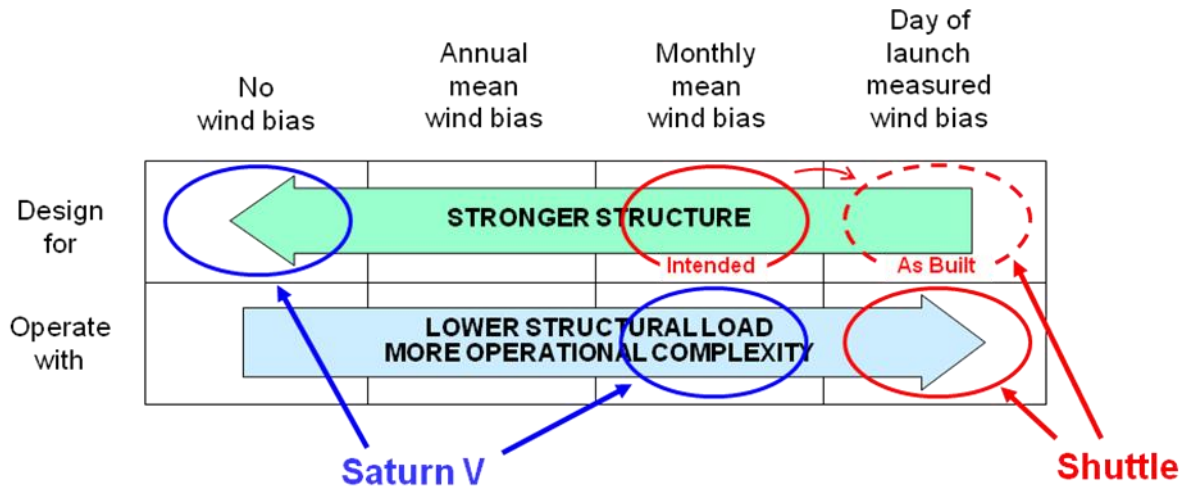

- Operating with day of launch bias gives minimum structural load.
- A spread between “Design for” and “Operate with” provides margin that can be traded for payload performance and/or launch probability.

Figure 6-6. Comparison of Wind Biasing Approaches for Saturn V and Shuttle

Saturn V Load Relief Trade

On the Saturn V / Apollo vehicle, the usual trade study was done to determine potential benefits of using load relief control. Analysis that modeled the vehicle as a rigid body showed that there was sufficient reduction of basic aerodynamic loads to recommend using load relief control. However, when structural flexibility was included in the analysis, it was found that adding load relief control significantly *increased* the loads on the upper one-third of the vehicle, due to accentuated bending response to gusts. This detrimental effect on the upper third of the vehicle outweighed the beneficial effect of rigid-body load relief on the middle third of the vehicle, resulting in a decision to not use load relief on Saturn V. [Ryan, R. 1986, Geissler, E.D. 1970]. This example also illustrates the importance of employing sufficient fidelity in trade studies so as to avoid an erroneous conclusion.

Saturn used analog filtering technology in the flight control computer. Today’s digital filtering technology would probably enable more effective compensating for flexibility components of the accelerometer signal, so as to take advantage of load relief control without the detrimental effects.

Operations versus Vehicle Performance

There is a tradeoff between maximum performance and maximum operational efficiency. If we design to optimize payload performance or other measures of physical performance of a vehicle, it is likely to be highly tuned and sensitive to parameter variations and perturbations. Such vehicles are not robust and require much effort and cost to operate

safely. Historically, we have designed for performance, then dealt with the risks and consequences of a performance-based design through operational procedures. This approach comes at a high cost in operations.

We should balance the vehicle performance to achieve robustness, reducing the risk and therefore the operational complexities.

Solid Rocket Booster Water Impact / Recovery

The decision to recover and reuse parts of the Shuttle Solid Rocket Boosters is an example of a different type of trade and balance activity. The overall decision involved many technical and cost factors, and eventually was based on a probabilistic prediction of the attrition rate. Ascent payload delivery capability was affected by the mass of the recovery system including parachutes. Reusing the SRB's entailed development of recovery methodology, on-board systems, recovery vessels and infrastructure, refurbishment and inspection process, etc. [Nevins, 1975]

One aspect of this development was the prediction of what damage can be expected upon water impact. There are several events related to water impact that produce major loads on the SRB, as illustrated on Figures 6-7 and 6-8: (1) the initial splashdown causes large loads on the nozzle and aft skirt, (2) the air cavity created by the splashdown collapses and the water slams the aft part of the case, (3) maximum depth penetration creates hydrostatic loads, (4) the SRB buoys up vertically, then slaps down horizontally, creating side-loads on the forward part of the case. Any of these events has the potential to damage the hardware.

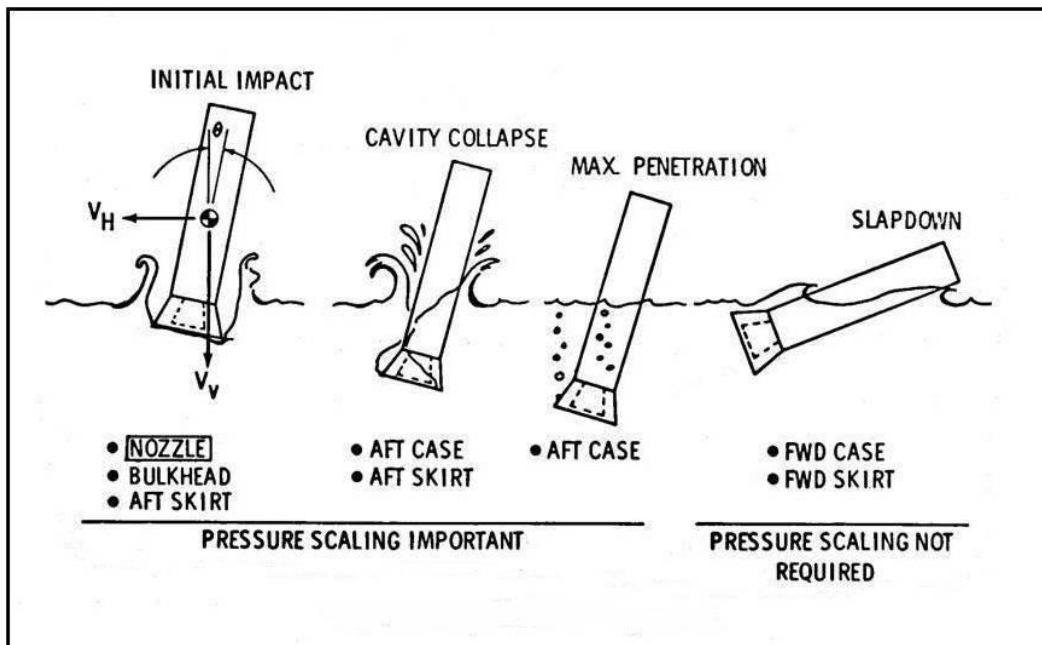

Figure 6-7. Significant Loading Events for SRB Water Impact

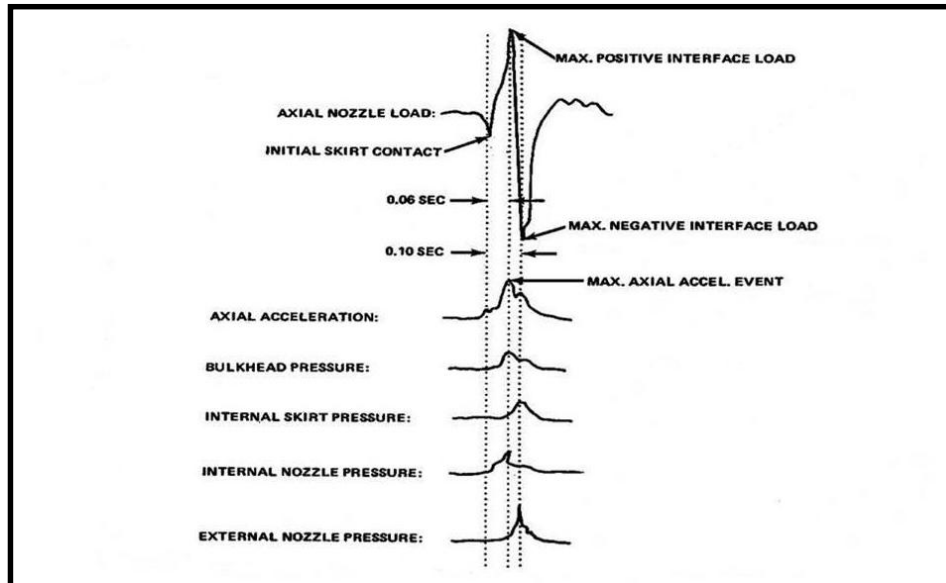

Figure 6-8. Typical Initial Water Impact Dynamic Events

There was a large amount of scale-model drop testing done during the development of the recovery system, along with some full-scale testing. There were trade-offs for parachute sizing and assessment of sea state probabilities, along with economic analyses to assess the cost benefit of recovering and reusing the hardware. The conclusion reached was that booster recovery and reuse would be cost effective if there were no more than 2% attrition of the hardware due to recovery damage. So there was a probabilistic balance-point, or target, for the recovery system design. The initial desire was to not modify the ascent SRB design for any recovery loading events, but to accept whatever attrition would occur. However, because the actual cavity-collapse loads were consistently higher than predicted, a design modification was made to strengthen the aft segment. While one pair of SRB's were lost because of a parachute triggering device malfunction, there have so far been no SRB's lost because of the probabilistically-defined variables such as sea states, parachute deployment conditions, etc. A major advantage of recovering the SRB's is the ability to inspect the recovered hardware and determine its post-use condition. This has proved important in determining actual margins (such as for thermal protection) and revealing incipient problems. [McCool, 1991]

Vehicle Reliability Versus Engine Reliability

Another act of balancing has to do with the trade of vehicle reliability versus engine reliability and the number of engines. Here we are trading engine reliability for vehicle reliability particularly in man-rated systems where we want engine out capability for abort. If each engine has the same reliability regardless of its size, the vehicle reliability is highest if the vehicle uses a single engine. But a single engine would imply high thrust, and high thrust engines tend to be more unreliable. Smaller engines have higher individual reliability, but the need for multiple small engines can reduce the overall vehicle reliability. This is illustrated by

on Figure 6-9. Reliability numbers in the figure are for illustration only and do not represent actual systems. As an additional consideration, a vehicle with multiple engines may be designed to allow engine-out capability as a safety measure for crew survivability or mission continuance. Airlines have dealt with this issue extensively and had difficulty for a number of years getting certification for twin engine versus four engine planes. They had to show a gain in engine reliability and the ability to fly on one engine to sell the approach.

Systems Reliability vs. Engine Reliability

- ✦ **Generally, the smaller the number of engines on a vehicle, the less likely an engine failure will be experienced during a mission.**
- ✦ **But, lowering the number of engines requires higher thrust engines, which can reduce the individual engine reliability. This entails a tradeoff.**
- ✦ **Designing for capability to safely abort (or even complete the mission) after experiencing an engine failure can significantly increase crew safety / mission success.**

Example:

| Single Engine Reliability | Two Engines - None Out | Three Engines - None Out | Three Engines - One Out |
|---------------------------|------------------------|--------------------------|-------------------------|
| 0.95 | 0.903 | 0.857 | 0.993 |
| 0.97 | 0.941 | 0.913 | 0.997 |
| 0.99 | 0.980 | 0.970 | 0.9997 |
| 0.999 | 0.998 | 0.997 | 0.999997 |

Figure 6-9. Systems Reliability versus Number of Engines

X-33 Aerodynamics and Controllability

Balancing the X-33 single stage to orbit launch vehicle was a major challenge. X-33, being a single stage to orbit vehicle, had to balance between the ascent and reentry aerodynamic characteristics. Ascent controllability and loads had to be balanced with reentry and landing controllability. Solving this balancing act took 1,000 hours of wind tunnel tests in the MSFC tunnel. There was an approximate 9 months hit in the vehicle development schedule required to solve this design set of trades. [David, 2001]

The above examples have illustrated the multi-dimensional nature of balancing that is required for the design process. There is balancing among all aspects of the system: subsystems, design functions, disciplines, performance, the -ilities, flight phases, life-cycle costs, and more.

✦ **A key message from Lesson 6:**

Balancing Required Among All Aspects of System:

- ***Subsystems***
- ***Design Functions***
- ***Disciplines***
- ***Cost / Performance / -ilities***
- ***Flight Phases***
- ***Life-Cycle Expenditures***

Principle IV: The System is Governed by the Laws of Physics

In this section we deal with the lessons associated with fundamental technical principles. In dealing with these principles, it is not implied that there are not other technical lessons; in fact most of the remaining lessons are of a technical nature. What we are doing here is dealing with four of the very high level technical lessons necessary for successful products. The four lessons for this principle are:

- 7. Physics of the Problems Reigns Supreme**
- 8. Engineering is a Logical Thought Process**
- 9. Mathematics is the Same!**
- 10. Fundamentals of Launch Vehicle Design Deal with Balancing Efficiencies**

Lesson 7. Physics of the Problems Reigns Supreme

- ✦ **The Physics (Mother Nature) of the problem reigns supreme (The God of Design). Either you bow down to Her or you will fall down.**

"Mother Nature does not read our paper. If we don't follow her way, she lets us fall"

- ❑ **Understanding the Physics is crucial.**
- ❑ **Designing using unrealistic assumptions results in program failure.**
- ❑ **Technologies must be fully verified before use. Verification as you fly increases risk and cost.**
- ❑ **Independent analysis is a great approach to risk identification leading to subsequent mitigation.**
- ❑ **The quality of the technical features determines project success.**

Designing a product optimistically--in other words, thinking that you can bypass “the physics of the problem”--will lead to failure. Physics will always win. As a result we must develop means of enhancing “Critical Thinking” in order to always fully understand the basic physics of the product. In addition as stated in the corollaries, we need to utilize other avenues to enhance our understanding. It is standard practice to assume unrealistic or too optimistic requirements. These must be challenged and brought into the realm of reality. The tendency is to baseline new technologies before they have are matured and verified. Technologies should be understood, matured and verified before incorporation in a product. Developing technologies in parallel with development and manufacturing is a high risk approach and is not prudent. Independent analysis and open inquiry are good techniques for assuring understanding of complex space systems. Lessons Learned should be brought to play in all phases of a products lifecycle. Finally “the quality of the technical features” determines the product success.

The following examples will be discussed to illustrate the lesson.

- SRB Aft Skirt Failure
- Skylab Loss Of Thermal Shield / Solar Array
- SSME Turbine Blade Cracking
- SSME Duct Bellows
- SRB Reentry Acoustics
- Heating Impacts

Space Shuttle Aft Skirt Failure

The Structural Test Article structural qualification of the High Performance Motor resulted in a failure of the SRB aft skirt at a safety factor of 1.28 (versus the required 1.4) in the hold-down post region. As a result the SRB Aft Skirt flew for many flights with a waiver before installation of a fix. The problem is a very complex load path situation that occurs due to the vehicle weight and SSME thrust-induced loads bending the vehicle over the outer SRB posts. The SRB skirt angle transfers these longitudinal loads into a lateral and longitudinal load situation causing the skirt skin to bend against the hold down post where it is welded to the hold-down post as shown on Figure 7-1. [Townsend, 1998]

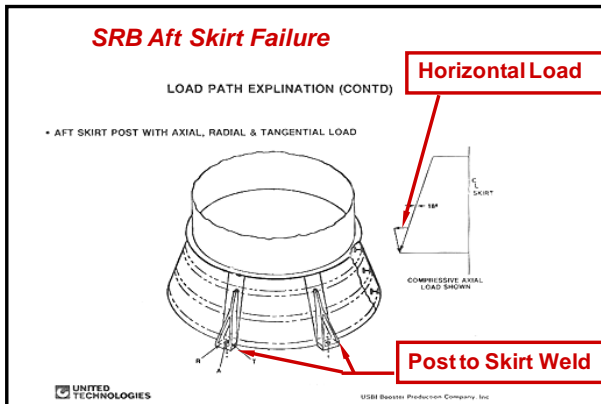

- The SSME thrust bends the vehicle over the 2 SRB Holddown posts, putting a compressive load into the skirt.
- The skirt flare angle creates a horizontal component of the thrust, pushing the post outward, putting a bending moment in the weld, which led to a test failure at a safety factor of 1.28 vs. the required 1.4

Figure 7-1. SRB Aft Skirt Failure at the Holddown Post Weld Area

Figure 7-2 shows the magnitude and distribution of the stress introduced by the load. The figure below is a linear analysis that indicates the peaking of the stress but not its real amplitude. The actual stress of the weld was highly nonlinear and requires a nonlinear analysis and special materials characterization to understand the issue. As a result of the test failure of the SRB aft skirt, the Space Shuttle flew the skirt under waiver through flight 86. Flying with a waiver required constant monitoring of the loads on each flight, special inspections and special analysis in order to fly the system safely. This required approximately 5 equivalent full time engineers to accomplish. At that juncture in the program a fix was instituted, gaining back the margins and removing the waiver.

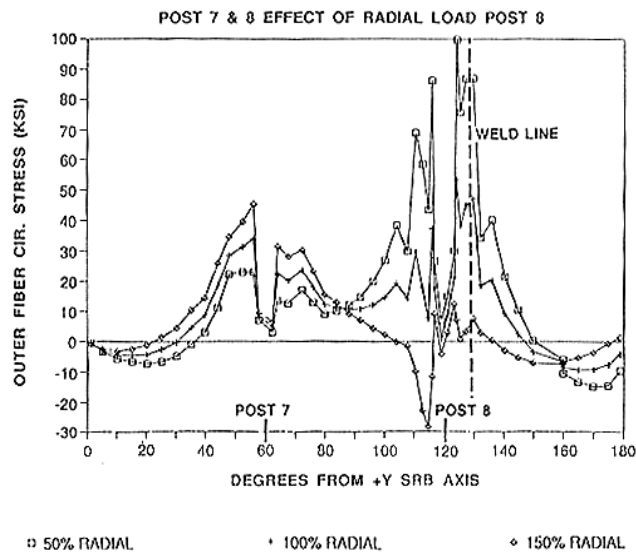

Figure 7-2. SRB Aft Skirt Stress Distribution

X-33 Shortfalls

X-33 was a scaled model technology demonstrator for a single-stage to orbit launch vehicle scaled at 40% of anticipated full size SSTO. The goal of the project was demonstration of the critical technologies -- mass fraction, metallic TPS, integral shape composite fuel tanks, aerospike main engines, coupled ascent and reentry aerodynamics and control systems, and simple low cost operations. Demonstration of TPS needed trajectories that reached a Mach number of at least 18. The mass fraction requirement needed to be demonstrated at approximately 0.9 in order to say you could extrapolate to full scale.

Major shortfalls were the following:

1. Weight growth precluded reaching orbit / Weight growth limited Mach number needed to verify TPS and didn't demonstrate acceptable mass fraction.

This shortcoming had to do with large mass growth to solve tank problems, aerodynamic problems, and was limiting the achievable Mach number to 12 or less. This was hampering the ability to verify the TPS. The same mass growth was pushing the mass fraction to around 0.85 making it nearly impossible to extrapolate the results to full scale.

2. Missed coupling of aerodynamics and control (Uncovered in wind tunnel testing).

During wind tunnel testing it was found that the ascent and reentry aerodynamic characteristics were in conflict requiring a reorientation and resizing of the canted fins. It took 1,000 hours of wind tunnel testing to reach a compromised solution that ended up with some undesirable reentry and landing response and higher loads and performance loss during ascent.

3. Composite integral fuel tank failure

The integral composite fuel tank failed during verification testing. See Lesson18 for details. This failure ended up with the cancellation of the X-33 program.

Gravity Probe A - Redshift

If a spinning object has internal energy dissipation, it will orient itself so that the spin is about the axis of *maximum* moment of inertia (e.g., a long cylindrical object will flip into a flat spin). The initial design of the GP-A spacecraft was spun about the axis of *minimum* moment of inertia, and it had internal fluid (ammonia for the thermal system) that would slosh. The problem was recognized before launch, and the internal components were repositioned to make the moment of inertia maximum about the spin axis. The mission was successful. Figure 7-3 illustrates the phenomenon where the figure on the left is spinning about its minimum axis, while the figure on the right is spinning about the maximum axis and is stable.

Gravity Probe A (Redshift)

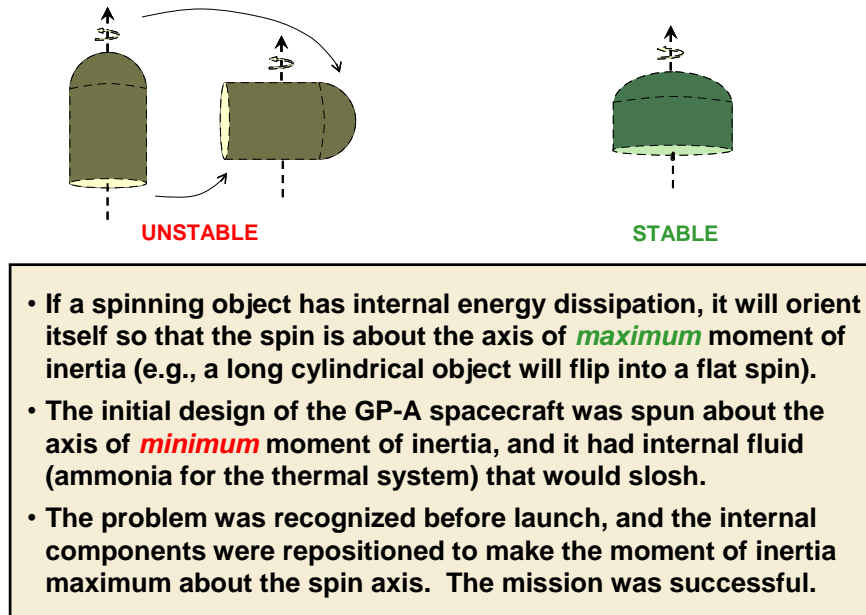

Figure 7-3. Model Illustrating Effects of Spinning About Minimum and Maximum Axes of Moment of Inertia.

Aerodynamic Venting Failures

There have been at least three similar venting incidents in the history of space flight. Two resulted in the loss of the vehicles and one crippled the payload. Those lost were the Atlas-Able-Pioneer (1959) and the Atlas-Centaur (1966). The one crippled was the Saturn Skylab (1973). The similarity in these incidents was that each had a shroud that came off during the transonic flight regime. In the first two incidences, the understanding of the flow physics was not known. Had it been known, the shrouds would have been designed so that they would have been under crush loads; however that was not the case. They were unknowingly designed so that during transonic flight the shroud load was a burst load that resulted in failure. These failures could have been prevented had the shrouds been adequately vented.

In the case of the Saturn Skylab an auxiliary tunnel was not adequately vented. The venting analysis was predicated on the assumption that the tunnel would be completely sealed at the aft end, but the aft end as manufactured was not sealed. The openings in the aft end were a result of lack of “technical integration.” The fact is this critical sealing requirement had not been communicated between aerodynamics, structural design, and manufacturing personnel, see [Lundin, 1973]. Furthermore, “system engineering” was not adequate. There was no dedicated project engineer and that resulted in lack of effective integration.

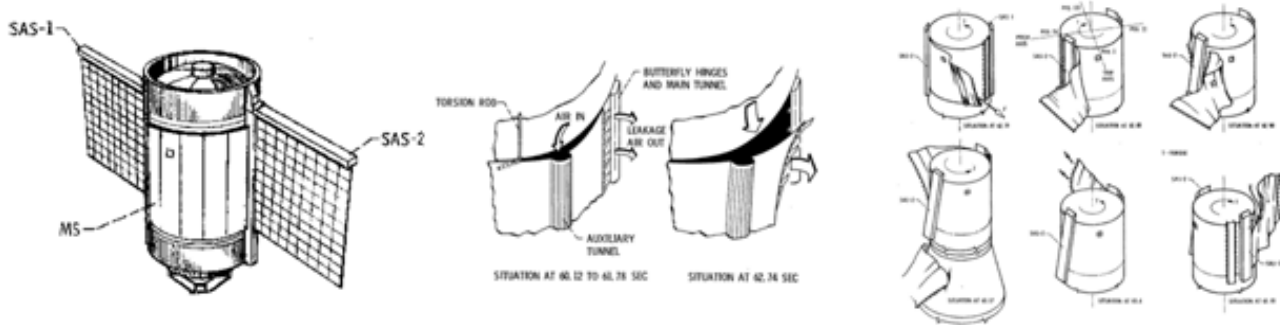
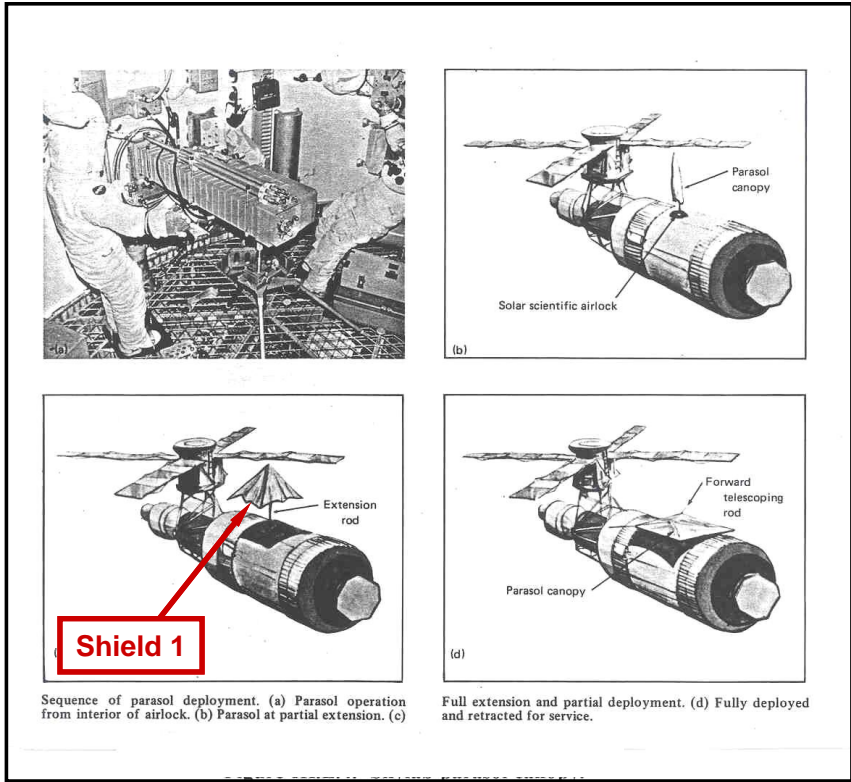

Figure 7-4. Saturn Skylab Solar Array System (SAS)

Shown in Figure 7-4 is the Skylab SAS. The first figure shows the system as it should have been deployed. In the middle figure, the destructive liftoff of the auxiliary tunnel as a result of the transonic flow induced burst load can be seen. The figure on the right shows the unwrapping of the micrometeoroid shield that was also a thermal shield. While the vehicle was not lost, the payload was crippled. However, eventually, a sun shield was added for thermal protection and the mission was saved. Saving the Skylab was a complex process that required two mission EVA activities. Ground and satellite pictures showed the damage and what had to be accomplished in order for the spacecraft to be operational. They showed that one of the solar arrays was destroyed and the other was jammed with parts from the failed structure. Also it showed that the thermal shield was destroyed resulting in high temperatures within the living quarters etc. The first crew carried cutters for unleashing the jammed solar array and a parasol that could be installed through a scientific lock. Unleashing the jammed solar array required an EVA activity for the crew that had some risks due to the dynamics of the release of the partially deployed array when the jamming strut was cut. These two activities were performed and the first crew then completed the science part of the mission after they had activated all the systems of the Skylab and the Apollo Telescope Mount. The temperature within the workshop was higher than desired by the crew so on the next flight a larger thermal shield was deployed. This required another EVA to first install the two long telescoping poles from the ATM along the workshop. Once they were installed then a new thermal shield was installed on the poles covering the shield from the previous flight and a much larger area of the workshop. This fixed the temperature problem. The only remaining issue was the limited power restoration ability of having only one solar panel instead of two. This was handled by mission event planning and then the remaining missions were very successful. See Figure 7-5 for the first fix and Figure 7-6 for a picture of the final configuration.

This in-flight anomaly was a result of failures in both technical integration and systems engineering. All the requirements were not communicated. In reference, [Augustine, 1983], there are fifty-two laws (Augustine's Laws). The forty-fifth law states, "One should expect that the expected can be prevented, but the unexpected should have been expected."



- Inadequate venting of the Solar Array container during ascent destroyed one solar array and the Workshop insulation.
- On-orbit installation of thermal shields by the astronauts was required during first mission occupancy.
- Initially a parasol was deployed through a viewing port, with a larger shield deployed on the second mission.

Figure 7-5. Skylab Initial Thermal Shield Deployment

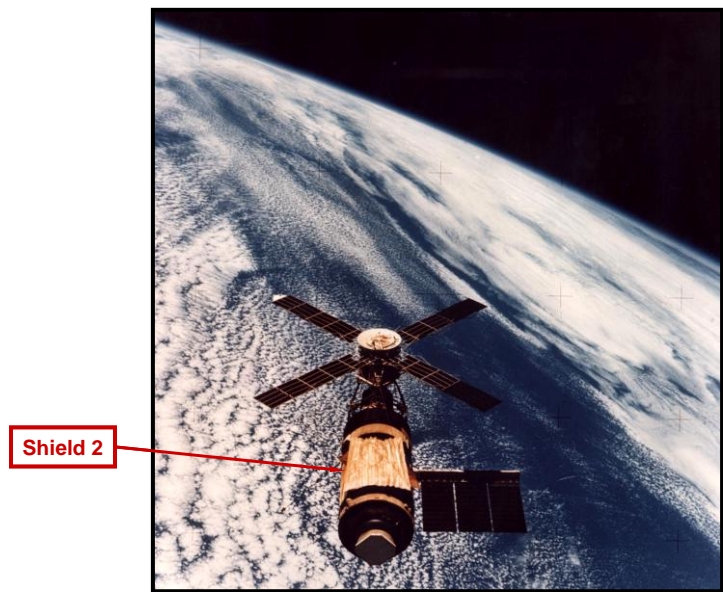

Figure 7-6. Final Skylab Configuration with Second Thermal Shield Deployed

SSME Fatigue Issues

The high performance of the SSME coupled with the high power density, discussed in the earlier section on the challenge of space travel, created many fracture and fatigue problems. [Ryan, et al, in Chaffe, 1983] The high pressure turbo pumps turbine blades is one classical example. There were two types of fatigue experienced in the SSME program: (1) Low cycle fatigue, (2) High cycle fatigue. The low cycle fatigue is introduced by the cycle between low and very high pressures and temperatures. At maximum operating conditions the temperature is 1800 R and at shutdown the pump is purged with low temperature gaseous nitrogen. The fuel pump with its preburner is about 3' long, weighs 750 pounds and rotates about 30,000RPM, generating 70,000 HP. Each turbine blade, about the size of a man's thumb, generates 550 HP. As the turbine spins, the driving gas is guided with vanes, which creates a fluctuating pressure on the each blade as it passes each vane. This introduces vibration in the blade that leads to high cycle fatigue.

The fix for the high cycle fatigue was to install a damper between the blade platform and the wheel it is mounted in. During the test where the failure occurred the gold plating used on the damper to eliminate hydrogen effects failed and the blade damper became ineffective. The fix involved disallowance of platings on the damper. No additional problems occurred with this blade during the tenure of the Rocketdyne pumps on Shuttle. Figure 7-7 shows the fuel pump blade; Figure 7-8 depicts the LOX pump blade that had a low cycle fatigue problem. The low cycle fatigue was caused by the thermal cycling the blade experienced in going from a very high operating temperature to ambient temperature during shutdown. The crack growth phenomenon was controlled through inspections, ground test hot fire history and the application of the 50% fleet leader rule. This rule says that no part can fly on a Shuttle mission that does not have twice the time on two identical parts in ground tests. This rule has been applied to all critical SSME parts and components.

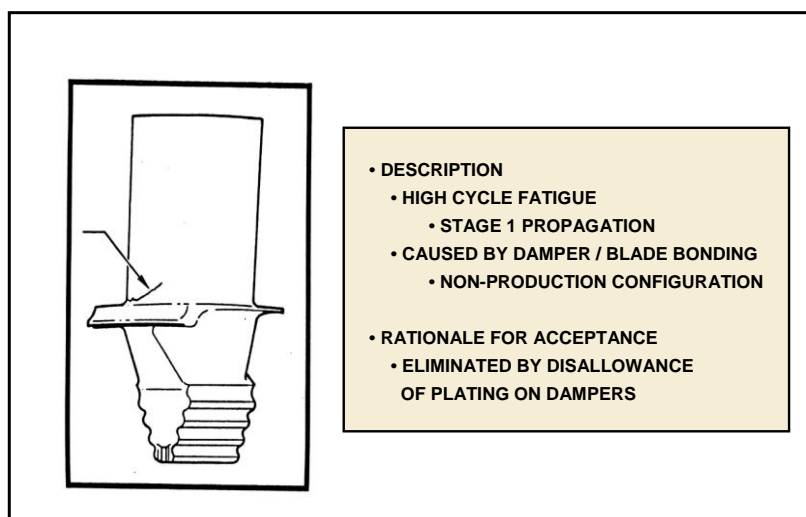

Figure 7-7. Fuel Pump Turbine Blade High Cycle Fatigue

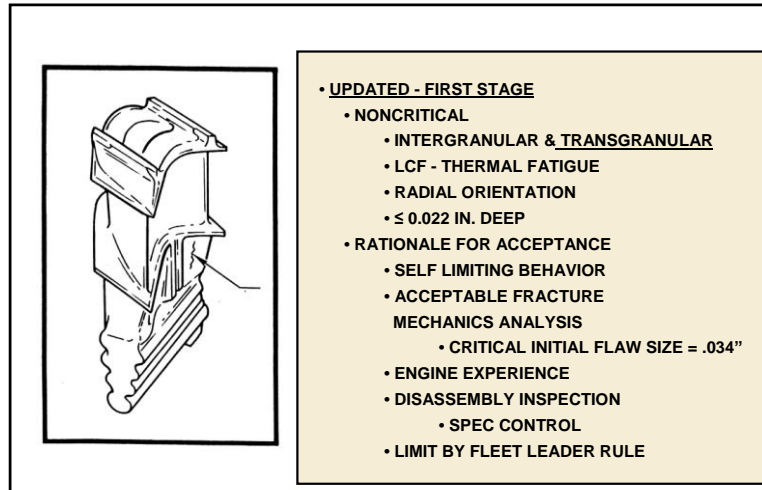

Figure 7-8. LOX Pump Turbine Blade Low Cycle Fatigue Problem

There have been many technologies tried, some with success, to solve the problem of a blade operating in such an extreme environment. Various materials, in conjunction with growing the blades as single and double crystals have been developed and used; however, operating in these extreme environments will always be a complex and daunting challenge. Sensitivities, uncertainties and risk are means whereby mitigation approaches such as the 50% fleet leader rule are developed to ensure mission success and flight safety.

Low Pressure Fuel Duct Bellows Failure

The low pressure fuel pump on the SSME is connected to the high pressure fuel pump by a duct that has three bellows, see Figure 7-9. This duct design enables the SSME to execute gimbal motion during static testing and ascent flight.

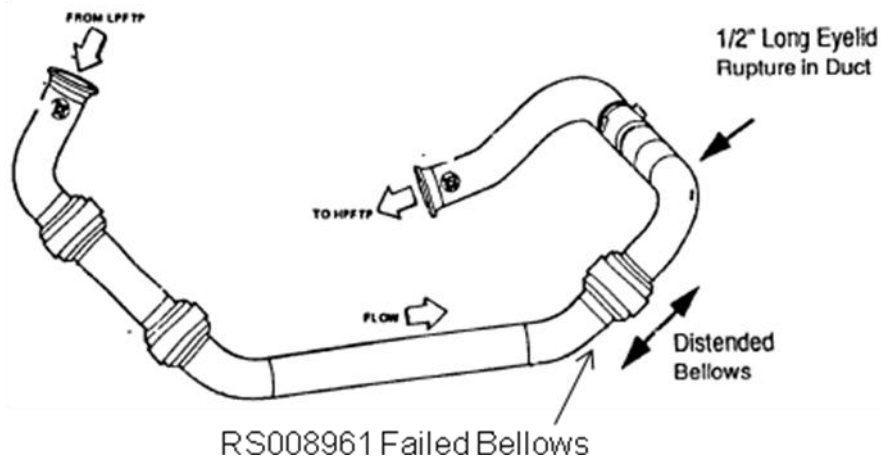

Figure 7-9. Bellows Flex Joint

The flex-joint is composed of a flexing bellows that is rigidly attached to the ducts on each side of the bellows. Internally this is accomplished using a gimbaling tripod as shown on Figure 7-10. The propellant flow across the gimbal causes it to vibrate, fatigue, and crack as indicated on the figure.

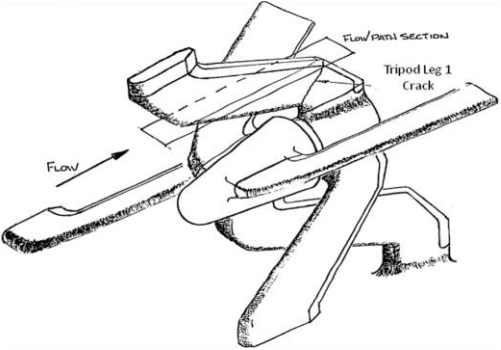

Figure 7-10. Flex Joint Internal Tripod Tie

During static testing of engine 2206, the RS008961 bellows failed due to a high cycle fatigue crack that initiated at the inner radius of tripod leg 1. When the tripod separated, it produced projectiles that traveled downstream and impacted the fuel duct wall causing a hydrogen leak, see Figure 7-11.

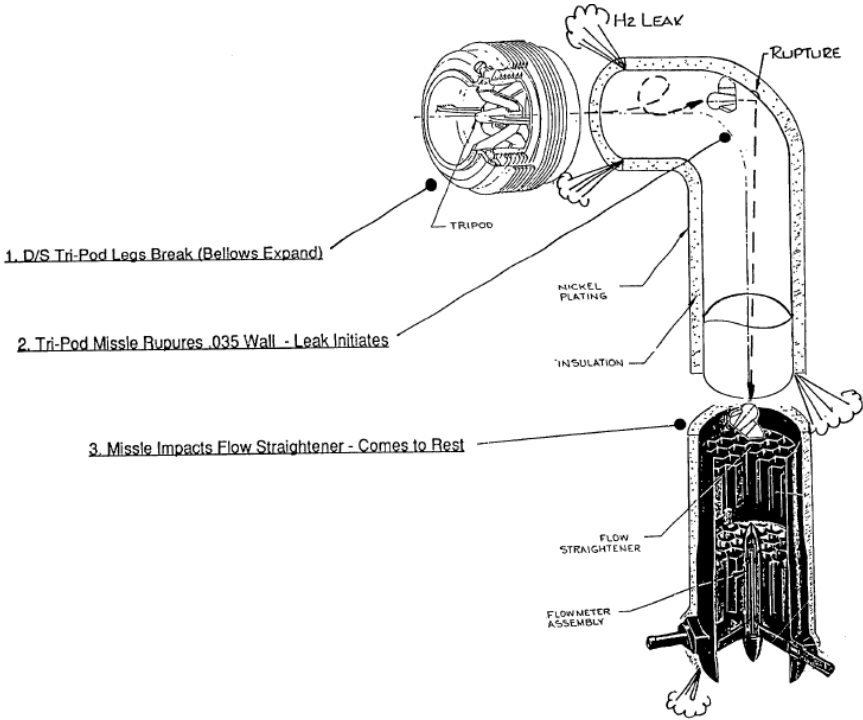

Figure 7-11. Bellows Failure and Duct Rupture

The test history associated with this duct was: 90 starts, 31,853 seconds, and 19.54 equivalent gimbals cycles. The fleet leader had 36,114 seconds of hot fire. Subsequent investigation revealed the fatigue cracking started at the inner dogleg radius as a consequence of missing a drawing requirement. This radius was found to be significantly smaller than specified by the drawings. At the failure location the cross-section was machined incorrectly to an area smaller than specified. Thus the failure was attributed to misinterpretation of drawings, inadequate manufacturing, and inspection procedures. The corrective actions included revising drawings to clarify dimensioning of the cross-sectional area and procedures were revised to inspect the tripod geometry during final assembly and subsequent welding. As a result of this and other failures of this type, the SSME and Shuttle project has adopted a 50% fleet leader rule for the engine parts as discussed previously. This approach has been very successful since there have been no SSME flight failures.

Solid Rocket Booster Reentry Acoustics

During reentry of the SRB after it boosts the Space Shuttle, its trajectory exhibits random characteristics with the angle of attack varying from 96 to 180 degrees and with the dynamic pressure varying from 360 to 1,020psf for a 95 percentile envelope at a reentry Mach number of 3.5. During the design phase, pressure fluctuations of 189dB were predicted on the nozzle extension and later verified in wind tunnel tests. To mitigate any adverse effects, the nozzle extension was severed at apogee. Shown in Figure 7-12 are wind tunnel results at a Mach number of 3.5 without the nozzle extension.

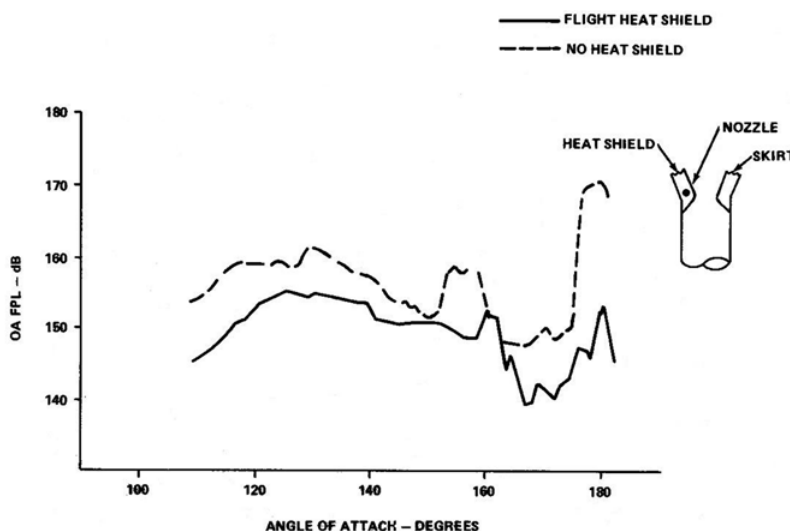

Figure 7-12. SRB Reentry Fluctuating Pressure Levels without Nozzle Extension

It can be seen that without a nozzle extension the overall fluctuating pressure levels (OAFPL) are significantly below 189dB. In addition, having a heat shield reduces the levels. A description of the reentry trajectory, wind tunnel testing, and scaling is provided in reference [Schutzenhofer et. al., 1979]

The effect of the having high OAFPL's on the system was not understood. It was decided to instrument the SRB with dynamic pressure transducers to measure the levels with the nozzle extension on. Shown on Figure 7-13 is the OAFPL on the nozzle extension through the reentry. These are root-mean-square (rms) values converted to decibels as function of time. The oscillatory variations are due to the oscillatory variations in angle of attack. It can be seen that there were high levels (>190dB) as predicted and measured in wind tunnel testing. However, there was no dynamic tuning with the structure or electrical/hydraulic components. Thus while the OAFPL's were high, their effect was benign and the project decided to sever the nozzle at different time during reentry.

In this case, the unknown aero-acoustic event was *anticipated!* The project implemented a fix to mitigate potential effects of the high fluctuating pressure levels. Even though the OAFPL's were high, the fix was eventually changed since the response of the structure and electrical/hydraulic components was benign.

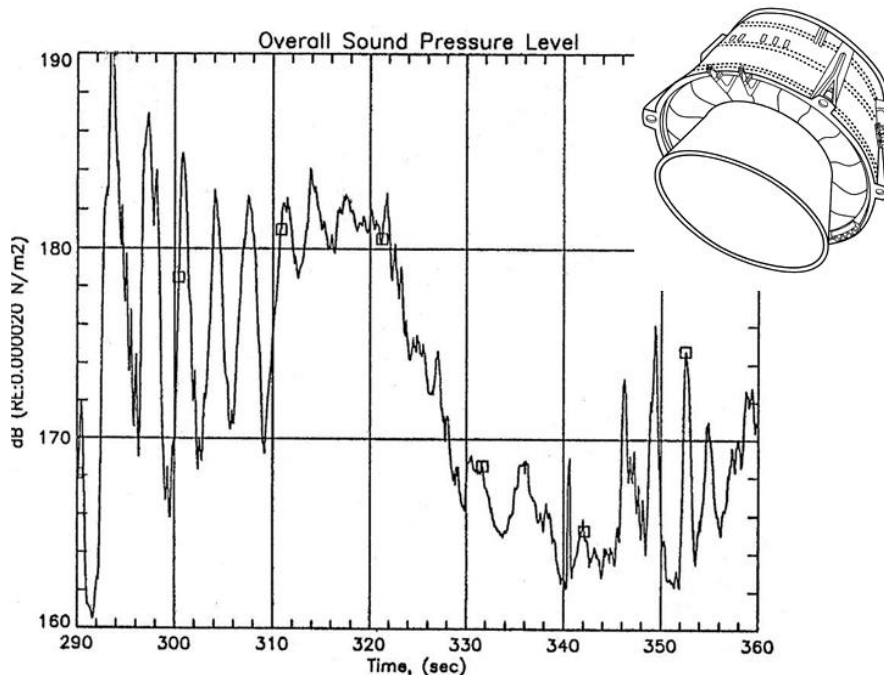

Figure 7-13. STS 6 Aft Nozzle OAFPL with Nozzle Extension

Plume / Base Flow Heating

During the first Jupiter flight there was an in-flight anomaly where burning in the base of the vehicle resulted in loss of vehicle. The root cause was entrainment and burning of gas discharged from the turbine of the Rocketdyne A-7 hydrocarbon engine.

Shown in Figure 7-14 is the Jupiter 1 in flight. The figure on the left is early in flight where the pressure in the base is lower than free stream static pressure (atmospheric pressure). The smaller stream of gas, seen in the base, is the fuel rich turbine exhaust flow.

The interaction of the base flow and the plume is benign. The figure on the right is prior to loss of vehicle at high altitude. In this situation the interaction of the plume and base flow is significant. The pressure in the base is higher than that of the free stream pressure. The turbine exhaust gas was unexpectedly entrained and recirculated in the base where the fuel rich gas ignited and burned in the base region resulting in loss of vehicle. A heat shield was added to mitigate effects of base burning.

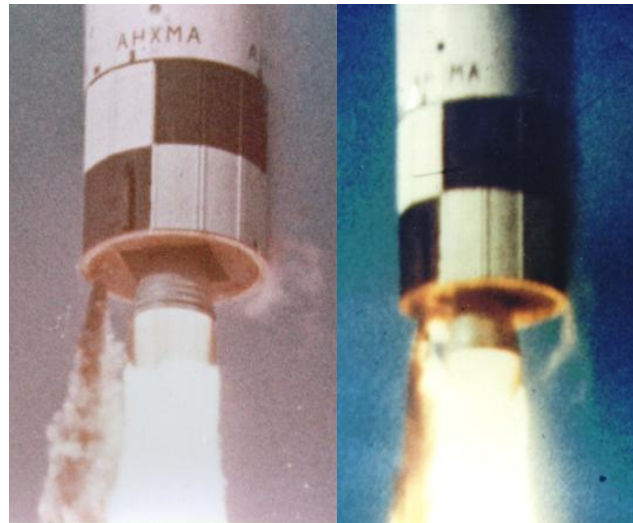

Figure 7-14. Jupiter 1 Base Flow

The illustration in Figure 7-15 shows a comparison of a flow field at low altitude to that of one at high altitude. It can be seen that at low altitude where the pressure in the base is lower than the free stream pressure, the flow is aspirated through the base area. However, at high altitude, where the free stream pressure is lower than the base pressure, the flow field in the base is reversed with hot gas from the plumes being recirculated increasing the thermal environment.

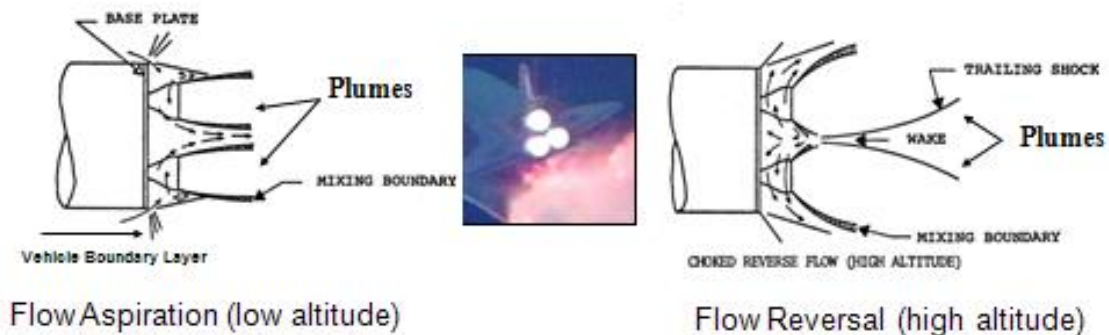

Figure 7-15. Plume Induced Base Flow Field

Other vehicles have also experienced significant plume induced separated flow. Shown on Figure 7-16 below are the plume flows for the Space Shuttle and Saturn Apollo. In the case of the Space Shuttle the plume flow was expected but the effects were under predicted. This resulted in unexpected loads that required fixes that cost 5000 pounds of payload. In the case of the Saturn, the plume size and shape were unexpected; however, there were no significant impacts to the vehicle.



Figure 7-16. Space Shuttle and Saturn Apollo Plume Flow

✦ **A key message from Lesson 7:**

Our Systems Are Governed by the Laws of Physics –

You Can't Wish It Away,

You Can't Analyze It Away,

You Can't Ignore It.

Lesson 8: Engineering is a Logical Thought Process

- ✦ **Engineering is a logical thought process, not a collection of computer codes. Learn to think; use the computer to enhance the thought process.**

Engineering is based on the laws and principles of physics; therefore, engineering and engineering design is a logical process that considers the various options available within the constraints of the applicable principles. The basic skill required is the ability to think in terms of the principles in a logical manner. Computers, tests, analysis are therefore tools that provide information for the human mind to accomplish the design. There are many examples in space history that can be used to illustrate the lesson. The SRB aft skirt problem was discussed previously; two will be discussed here.

The following examples will be discussed to illustrate the lesson:

- Saturn V Sloshing Computer Program.
- Space Station Node Gusset

Saturn V Sloshing Computer Program

During Saturn V development, propellant sloshing was a major concern. Tools for analyzing the interaction of the vehicle, the vehicle control system and propellant sloshing were in a state of development. While laboriously checking out the program to compute sloshing dynamics using computer priority, we kept making program changes due to errors found, which required new punched cards and card assembly. The computer operator finally asked Robert Ryan, "If you know the answer why are we running the program?" He replied, "If we didn't know the answer we should not be running the program." In other words we need to know the physics of the problem so that we can continuously check the computer program. Computer programs only give you what you ask them to. This check is made using simplified equations and back of the envelope calculations in terms of the basic physics of the problem. Helmut Horn, our early German supervisor, would make you go to the blackboard and show a simple model of the more complex model being discussed. He said that if you couldn't explain it in simple terms you did not understand it. He wanted you to use that same model to check out the computer results or even someone else's work or presentation.

ISS Node Load Paths and Common Berthing Mechanism Fretting

The ISS Node (Figure 8-1) had two major problems during development. The first had to do with the berthing ports gusset yielding during proof testing. The second was the galling of the common berthing mechanism during berthing simulations.

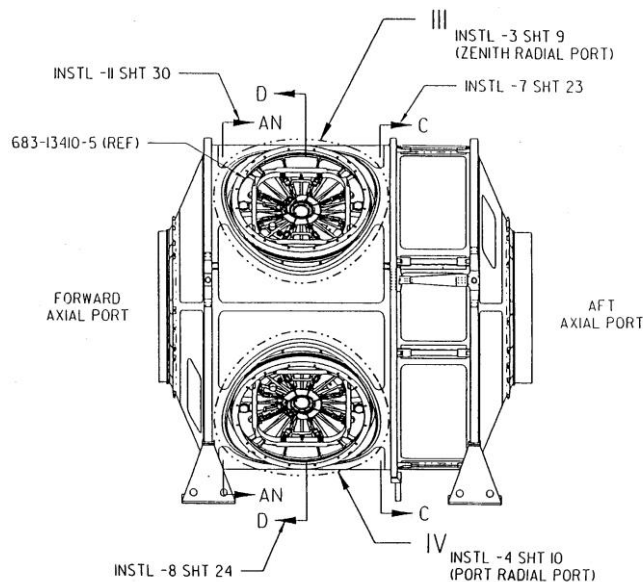

Figure 8-1. ISS Node Showing Berthing Ports and Gussets

The gusset yielding was found in the proof pressure testing and was a classic load paths problem created by trying to save weight and not understanding the primary load paths. The hoop stress was all dumped into the two gussets installed on the radial sides of the berthing port. Understanding load paths is critical to the design of structures. Pugh has written articles and has sections in his books on designing for load paths. [Pugh, 1991] Load paths are one of the basic physics of the design that must be adequately understood and designed for.

The berthing mechanism was tested extensively on the 5 degree of freedom motion simulator at MSFC's computational laboratory. During test the mechanism would gall due to the unpredictability of the contact angle. This was a result of the fact that the berthing was accomplished using the remote manipulator system (RMS) which had no unique position to bring in the second body because of the multiple joint angle possibilities. This contact angle depended on how the RMS captured the second body and its position relative to the station. The problem was solved once the total motion possibilities were clearly understood (initial conditions) and it has performed flawlessly during ISS missions. [Ryan's working papers]

✦ **A key message from Lesson 8:**

***Engineering is a Logical Thought Process
Instead of Blindly Applying Processes and Codes***

- ***Think Critically***
- ***Understand***
- ***Explain***

Lesson 9: Mathematics is the Same!

✦ ***The mathematical expressions (describing equations) for our systems' physical processes are the same. The difference is in the dimensions (units) and boundary conditions.***

The following mathematical categories illustrate the lesson:

- Algebra and Geometry
- Ordinary Differential Equations
- Partial Differential Equations

The fact that mathematics can describe the physical phenomena of nature is astounding. In addition the fact that mathematics, using the same forms, can describe all of the various areas of physics is even more astounding. Of course algebra and geometry is basic to all; however, the use of ordinary and partial differential equations is also foundational. Since the same form of the differential equations describe all the various disciplines then we can make analogies between the various disciplines, by just changing coefficients and units. This was the basis for the analog computer that many of us grew up

using to solve our equations. This also means that we can think in disciplines other than our specialties using this transformation. The basic message then is that we must be proficient in the use of mathematics while at the same time understanding the difference in the phenomenon that is being observed. We can use the similarities to a great advantage but in the end “the physics of the problem rules”.

✦ **A key message from Lesson 9:**

Learn the mathematics. It is the foundation of all analysis and modeling.

Lesson 10: Fundamentals of Launch Vehicle Design

- ✦ **Challenges of launch vehicle performance**
- ✦ **The fundamentals of launch vehicle design are:**
 - ▣ **Propulsion system efficiency**
 - ▣ **Structural (non-propellant mass) efficiency**
 - ▣ **Managing the losses**

The design of a launch vehicle is concerned with getting a payload to orbit in an effective and efficient manner. To design and operate a space launch vehicle one needs to understand the physical basics of the system. The essence of this lesson is the elements of that fundamental understanding: propulsion system efficiency, structural efficiency and managing the system losses. Overcoming gravity makes this a very challenging job as discussed in Lesson 3. To accomplish this task we must have highly efficient structures and propulsion systems and manage the losses in order to have a balanced system. The next section will discuss these fundamentals.

Figure 10-1 goes into more detail of the elements of the fundamentals of launch vehicle design. The discussion in Lesson 3 illustrated the complexity and challenge of space flight. Figure 10-1 summarizes the basic characteristics of the challenge. Emphasized is the fact that the technical, propulsion and structural efficiencies and managing the losses must be balanced and traded with the programmatic of cost, schedule and the -ilities. This balancing between the programmatic and the technical is a major challenge in that what we do to reduce cost and schedule greatly affects the technical. The process is further complicated by the fact that the technical requires that the design get all the performance possible in order to overcome gravity etc. Figure 10-1 depicts representative but not complete lists of the characteristics of the three fundamentals of launch vehicle design. Notice that for mass efficiency the three elements of mass fraction, packaging, thermal protection system are some of the things you can manage to get mass efficiency. Each though has many subsets; for example, mass fraction contains structural configuration, materials, loads etc. Propulsion systems deal with at least the engine cycle, Isp and engine thrust to weight ratio. Again each of these would have many sub parts. Managing the losses includes the generally known parts such as gravity losses and expands into environments, etc. A big effort is

dealing with uncertainties and interactions. Uncertainties must be clearly defined starting with an initial set. These uncertainties are then burned down as the lifecycle is moved towards operations. Interactions are very complicated and must be analyzed and controlled or the losses get very high. Interactions not understood are one of the major causes of problems in any launch vehicle system. The classic ones such as flutter, whirl, pogo etc. must be designed out of the system.

Launch Vehicle Fundamentals

Design Factors

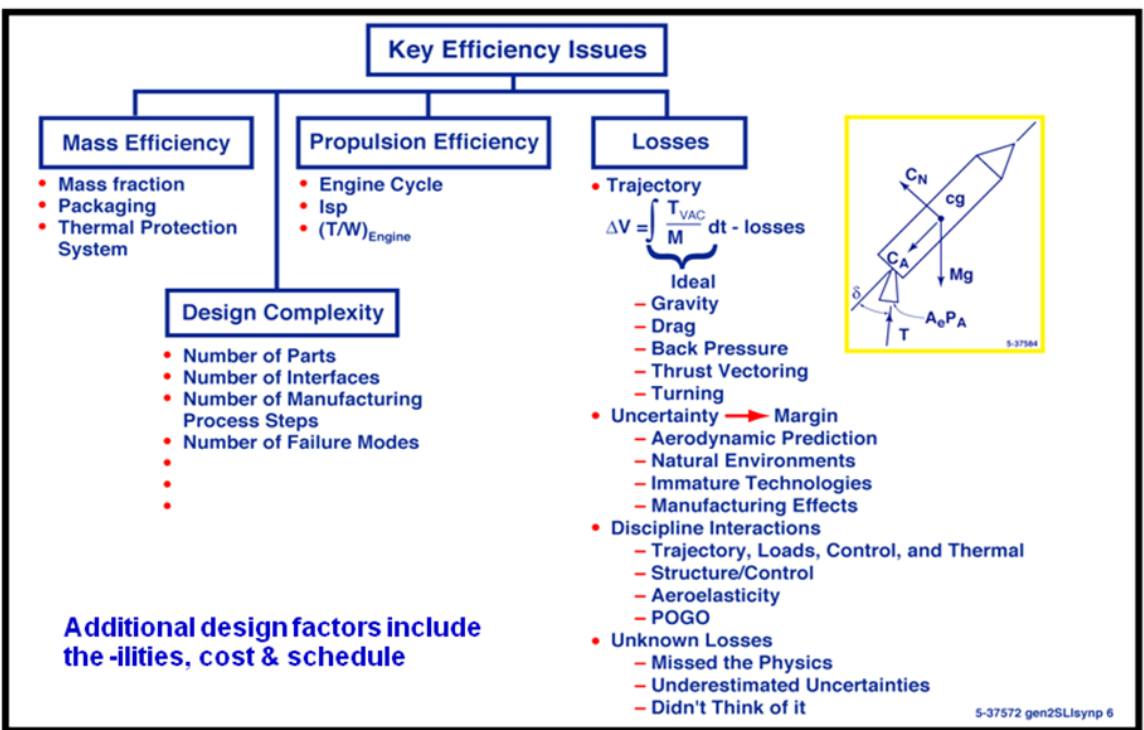

Figure 10-1. Balancing the Key Elements of Launch Vehicle Design

The following examples are used to illustrate the fundamentals of a launch vehicle design:

- Launch Vehicle Efficiencies
- Sensitivity Versus Performance
- Historical Mass Growth
- Typical Issues of Launch Vehicle Configurations

Launch Vehicle Efficiencies

The first example deals with the concept of balancing the efficiencies with the programmatic as shown on the list below. Early space system design was driven by performance and then assessed for the illities/programmatic. When the illities/programmatic is

placed on the design table with the first three principles, the balancing act of the design get very complicated. What is required is to develop functional relationships between the illities/programatics parameters and the design parameters of structures, propulsion etc. so that the design is a total system design. [Ryan, et al, 1977] For example if the system is not designed for cost in conjunction with the physical design one will never get minimum cost design. Accomplishing a total system design is one of the major challenges space systems design faces today. This will be further discussed in Lesson 17.

Challenge is to Balance Between

| | | |
|---|------------|--|
| <p><u>Performance</u> <u>Efficiencies</u></p> <ul style="list-style-type: none"> - Propulsion Efficiency - Structural Efficiency - Managing the Losses | <p>and</p> | <p><u>-ilities &</u> <u>Programmatics</u></p> <ul style="list-style-type: none"> - Reliability - Operability - Cost - Schedule |
|---|------------|--|

Sensitivity Versus Performance

One of the techniques we use to accomplish design is developing and quantifying the sensitivities of the system to the design parameter variations. Figure 10-2 shows the sensitivity of a single stage to orbit launch vehicle gross liftoff weight to the structural mass fraction and the propulsion system Isp. Notice that we have put two lines on the graph to bound the problem. The first is a limit on gross liftoff weight that was estimated based on efficient size for operations. The second is the practical limit on Isp. This limit is 453 out of a possible 460 seconds for a typical LOX hydrogen engine operating at a 6.0 mixture ratio.

As you can see there is only one design curve that lies well within the boundaries—that is for a mass fraction of .95, a value that is still unattainable. A 0.9 mass fraction has way too much sensitivity to Isp and is not practical as is 0.89. The message of this chart is that because of the sensitivities, a single stage launch vehicle is not practical using today's technologies. [Ryan's working papers]

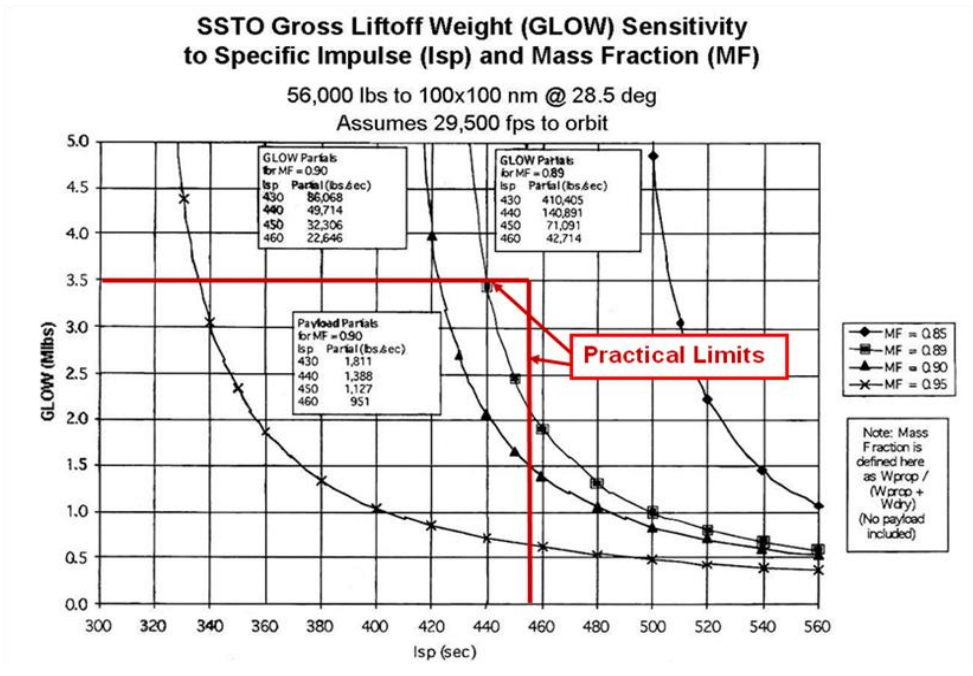

Figure 10-2. Effect of Isp and Mass Fraction Uncertainty Sensitivities on Vehicle Gross Liftoff Weight

Figure 10-3 shows the sensitivity of launch weight to launch weight margin assumed in initial design. Depicted using three different curves is the burn down of margin versus lifecycle. This plot is generic in nature and does not contain absolute values.

Dry Weight Margin Sensitivity

Impact of Design Phases on Sensitivity and Margin
SSTO Example, 25k to LEO

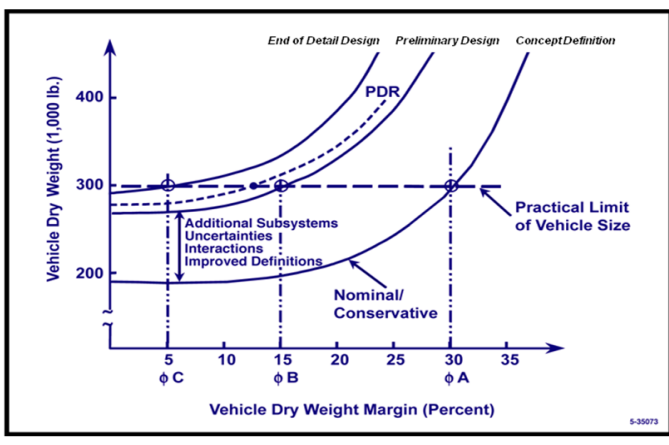

Figure 10-3. Launch Vehicle Dry weight Sensitivity to Dry Weight Margin

Historical Mass Growth

The reason we use dry mass margin initially is that history has shown that all space systems grow in mass as the lifecycle matures. The following list indicates factors in mass growth.

- Experience shows that space vehicles have mass growth
- Margins must be taken into account early in design process
- Technology exists to improve mass estimates
 - e.g. Vehicle Integrated Performance Analysis (VIPA)
- Categories where mass growth has to be taken into account
 - Vehicle dry mass (vehicle stages and payload)
 - Propellant reserve
- Primary causes for mass growth are
 - Improper definition of environments
 - Inadequate definition of subsystems
 - TRL not maturing as expected
 - Uncertainties not taken into account or controlled
 - Unknown unknowns

Figure 10-4 shows a data base of historical mass growth in various programs. [Alexander, et al, 2002] It is clear that initial design must account for this growth. The question then arises as to what is an acceptable mass growth margin and are there additional margins that should be used? A current practice for launch vehicles uses 15% on all new structure and 5% on all heritage hardware being used. In addition 15% performance margin is allocated to cover the losses discussed earlier and for program manager reserves for later unpredicted problems.

Historical Mass Growth (%) From ATP To Program Completion

| <u>Space Vehicles and Stages</u> | | <u>Aircraft</u> | | <u>Other Space Hardware</u> | |
|----------------------------------|--------------|-----------------|------------|-----------------------------|--------------|
| • Saturn I | | • X-20 | 44 | • Centaur | 22 |
| S-I stage | 16 | • XB-70 | 45 | • Thor | 5 |
| Interstage | 24 | • F4H | 15 | • Titan I | 10 |
| S-IV stage | 16 | • F101 | 7 | • Titan II | 2 |
| • Saturn V | | • F3H | - 4 | • Titan III | - 1 |
| S-IC stage 501 | 7 | • DC-8 | 6 | • Mercury | 28 |
| S-II stage 501 | 32 | • DC-9 | 7 | • Gemini | 18 |
| S-IVB stage 501 | 33 | • C-131A | 1 | • Apollo, Inert | 22 |
| • Space Shuttle | | • F-102 | 29 | | |
| Inert SRM (w/o DFI) | 6 | • F-111 | 23 | Average | 13.4% |
| Inert SRB (w/o DFI) | 13 | • F-106 | 4 | | |
| SRB Subsystems (w/o DFI) | 43 | • Concorde | 26 | | |
| ET, Standard, Inert | 10 | | | | |
| Orbiter | 27 | Average | 16% | | |
| • Inertial Upper Stage | | | | | |
| IUS (2-stage, dry) | 11 | | | | |
| IUS ASE | 122 | | | | |
| • X-33 | 57 | | | Overall Average | 21% |
| • X-37 | 25 | | | | |
| Average | 29.5% | | | | |

Figure 10-4. Historical Mass Growth of Space Systems

Typical Issues of Launch Vehicle Configurations

Depicted on Figure 10-5 is a list of other design complexities that can lead to weight increases and system complexities that must be understood and considered in design. Dynamic tuning of any multi-body configuration usually has large sensitivities of the dynamic response to events such as liftoff and gust response thus must be clearly understood and characterized. The same is true for all load paths and unsymmetrical geometries. Major interactions between subsystems, disciplines etc. are key drivers that are the source of many problems and therefore must also be characterized and designed out where possible. One principle is stated as: "The simpler the loads paths, in general, the more reliable the system." TRL levels of each element should be verified before incorporation into a design. Designing for robustness is nearly always a plus. Depth of analysis is determined by the system complexity and sensitivities.

Typical Issues of Launch Vehicle Configurations

1. Static unsymmetrical coupling
2. Dynamic coupling (symmetrical and unsymmetrical)
3. Load paths
4. Subsystem and discipline interactions
5. Subsystem optimization / TRL
6. Analysis depth / iterations / verification
7. Operability
8. Flexibility / Robustness



Figure 10-5. Additional System Considerations for Launch Vehicle Design

✦ A key message from Lesson 10:

Challenge is to balance between performance efficiencies and -ilities and programmatic

Principle V: Robust Design is Based on Our Understanding of Sensitivities, Uncertainties, and Margins

In the design of complex systems with high power densities there are always top level requirements, constraints, ground rules, and assumptions that set the stage for accomplishing the design. It is the designer's challenge to figure out how to strike balance among them. Included in the art of design is knowing how to apply sensitivities, uncertainties, and margins to achieve the best balanced design with confidence. Sensitivity analysis is a key tool to achieve the best balance among the design's attributes by assessing the changes in the attributes in term of changes in the design variables. This is accomplished by understanding the sensitivity factors (partial derivatives). It enables the designer to iteratively converge the design and involves the application of analysis, test, and simulations. Uncertainty pertains to random variations in design input variables at all levels and the





corresponding random variations in the design attribute (outputs). These variations are about mean values and are determined via historical data bases, tests, and expert opinions. Margin pertains to the difference between some measure of capability and some measure of demand. Understanding uncertainties and application of adequate margins throughout the various stages of the project provide the necessary confidence in the design of systems with high power densities.

The following are lessons related to this principle:

11. Robustness
12. Understanding Sensitivities and Uncertainties is Mandatory
13. Program Margins Must Be Adequate

Lesson 11: Robustness

Strategies that enable robustness

-  **Design for simplicity, number of parts, joints, interfaces etc.**
-  **Design structures for simplicity of load paths**
-  **Get the joints right**
-  **Don't overlay complexity with complexity in solving problems or issues. Overlay complexity with simplicity.**

The goal of design is to achieve the best balanced design in consideration of all requirements, constraints, etc. At the same time, the design needs to be robust. Robustness can be defined as follows:

1. A robust design is one where the response of the system is inherently insensitive to perturbations.
2. A robust design is one where the response of the system can be sensitive to perturbations, but can be adequately managed.

Robustness can be achieved by applying simple strategies; the following are some examples of those strategies. For instance, design for simplicity, minimum number of parts, simple joints and interfaces, etc. The original fuel turbopump housing on the Space Shuttle Main Engine (SSME) had about 469 welds and 315 were uninspectable and sections of the housing were sheet metal. The bearing material was 440C steel. When the alternate turbopump was designed the housing consisted of investment castings that eliminated welds and sheet metal. The bearing material is silicon nitride and the rotating assembly has about half the number of parts as the original design. Another design goal would be to simplify load paths. This would reduce stress concentrations and reinforcing substructures; thus, less weight. In addition, design joints so that the loads are spread out instead of focused to a point that has to be reinforced. Finally, don't overlay complexity with complexity in solving problems; overlay complexity with simplicity. To resolve rotordynamic instabilities in the SSME turbomachinery complicated design fixes were considered to stiffen the rotating assembly. However, a damping seal was implemented to stabilize the system. Application of the damping seal was simple in comparison to other approaches considered.

Examples:

- Six Elements of Robustness
- Saturn V Five Engines on the 1st and 2nd stages
- Saturn V Structural Capability
- Inertial Upper Stage (IUS) Robustness

Six Elements of Robustness

1. Margins/Tolerant Design

Sometimes the general notion associated with robustness is “add more margin.” If that can be done without compromising the design in terms of safety, performance, cost, and schedule, then it’s appropriate. However, in some situations adding more margin will not be appropriate and other means will be necessary to achieve balanced design goals.

2. Redundancy

Redundancy can be illustrated in terms of the number of strings of avionics added to the system. For instance, assuming no common-cause failures, if one string has a reliability of .9, two strings will be .99, and three strings will be .999. If one string has a reliability of .99, two strings will be .9999, and three strings will be .999999. Thus, this simple example shows what is involved in achieving various levels of system reliability with redundancy.

3. Simplicity

Simplicity is one of the most important aspects of a wisely designed system. For instance, it is simple to design, analyze, test, and operate. Achieving balance through sensitivity analysis can be simple as well as assessing uncertainty and eventually determining risk.

4. Desensitization to Parameter Uncertainties

Uncertainties usually pertain to random variations in a quantity about a mean value. The attributes (outputs) of the design are affected by design variables (inputs) and other parameters. Since there can be random variations in the inputs and parameters; there can be random variations in the output variables. For small variations, the output variations are about equal to the sum of sensitivity factors multiplied by random variations of the inputs (could also include parameters with random variation). This is the basis for the root-sum-square (RSS) methodology. Since there is a product relationship (sensitivity times random variation), by reducing the sensitivity factor the variation in the output can be reduced. This is an approach toward determining, controlling, and managing variations in the design attributes (output).

5. Control of Parameter Variations

In some instances control of parameter variations is difficult. For instance, a way of dealing with random variations in the atmospheric winds has been to measure day of launch winds and fly the vehicle for suitable conditions. In structural design, controlling tolerances is an approach that enables the structural designer to control stress and deflection. In avionics, the variation in electrical components can be controlled by hand picking parts that fall within specified tolerance limits. In all these examples, it can be seen that controlling parameter variations can have a significant impact on cost.

6. Operational Procedures

One of the goals of design is to minimize maintenance and operational procedures. In a generic sense, it would be desirable to reduce the number of purges, electrical checkouts, change out of components and parts, number of fluids (Initially, Shuttle had eleven major fluids), etc. In the early days of Space Shuttle flights, the turbomachinery was removed after every flight to replace turbine blades and bearings at the cost of three million dollars per pump. The life time of the present high pressure fuel turbopump is 3354 seconds; this includes one acceptance test and five flights. At the present time there will be no rebuild of turbopumps since there are enough flight assets to fly out the remainder of the manifest.

The above six elements and others are important factors that lead to robust balanced designs with minimal risk. They increase reliability and safety and reduce cost; they should be practiced through all stages of the design process and in operations. [Ryan, R., AIAA Paper 93-0974, 1993]

Saturn V Five Engines on the 1st and 2nd Stages

In the original conceptual design of Saturn/Apollo, there were four F-1 engines on the S-IC stage and four J-2 engines on the S-II stage. There were concerns regarding the weight estimates of the Saturn/Apollo system. A decision was made to add another F-1 engine to the S-IC stage to provide margin. Then a radiation shield was inadvertently omitted in the design of the spacecraft and had to be added. To account for the added shield, the S-II stage diameter was increased and a fifth J-2 engine was added. The addition of the fifth F-1 and J-2 engines provided margin that allowed for unexpected weight growth and future missions of the Lunar Rover and Skylab.

The loss of the fifth engine on the S-II stage during the Apollo 13 flight did not impact the mission. The other four engines burned longer to achieve the correct insertion velocity.

Adding these engines is an example of prudent design practice where margin enabled the moon landing, saved Apollo 13, and enabled Lunar Rover and Skylab.

Saturn V Structural Capability

The Saturn V composite design line loads are shown in Figure 11-1. The vertical axis is vehicle station in inches and the horizontal axis is the total structural load. It can be seen that the lower portion was designed by ground winds. (The term "designed by" means that the specified environment causes the maximum load event.) The interstages and upper part of the vehicle were designed by maximum product of dynamic pressure and angle of attack ($q\alpha$) and rest of the vehicle was designed by 1st stage cutoff. In addition, the safety factor is shown.

The design strategy used to develop these loads includes rigid and elastic body effects. This strategy was developed in the early design stages and resulted in a loads combination equation (LCE). This was an attempt to determine loads that would be equal to or less than the .99865 probability level. The Saturn V rigid-body loads strategy included: 1. 95% scalar wind speed (worst month), 2. RSS'd 99% wind gust and shear, 3. three- σ variations on all response parameters, and 4. no wind biasing. The elastic body effects included three- σ bending dynamics – turbulence. Additional margin was achieved during operations by flying with monthly mean biasing.

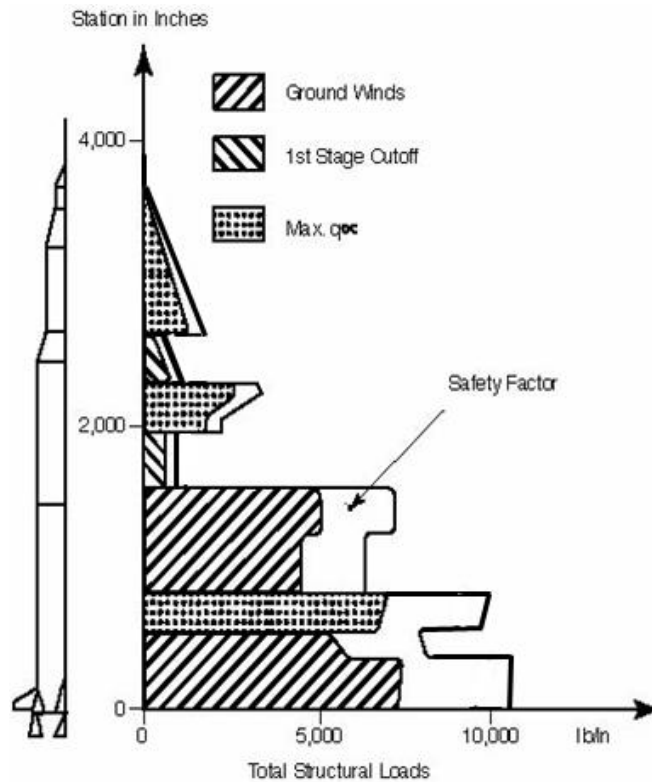

Figure 11-1. Saturn-V Composite Design Line Load

Strategies as shown above provided margin without compromising payload capability. In fact, it enabled the Saturn to be used for the Lunar Rover and Skylab.

Inertial Upper Stage (IUS) Robustness

The IUS is a highly redundant stage that can be commanded from the ground. It inserts payloads (~5000 lbs) into higher orbits (geo-sync) than primary boosters such as Shuttle or Titans. It operated from 1982 until 2004 that included 24 missions; 15 NASA and 9 DOD. In addition, it was functionally redundant. Shown on figure 11-2 is a description along with some of its characteristics, see reference [Dunn, 1984].

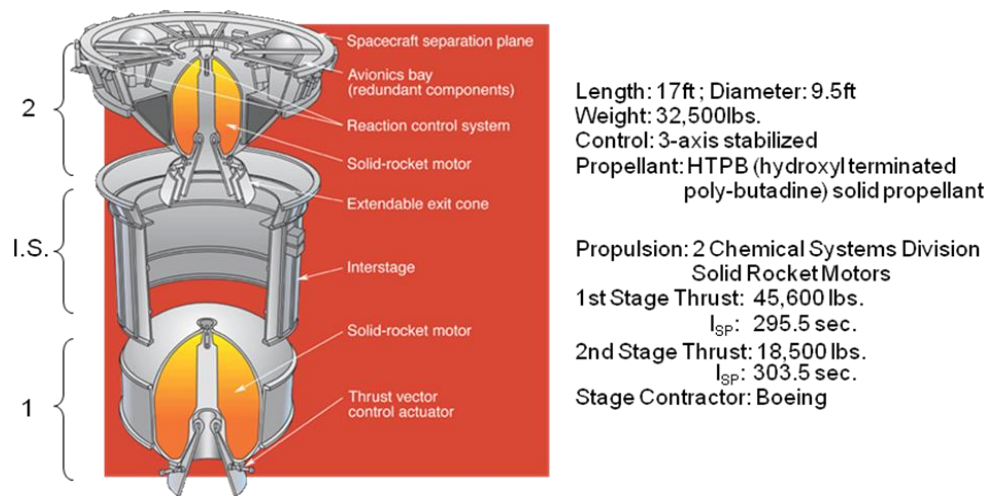

Figure 11–2. Inertial Upper Stage and Characteristics

The first stage boosts the second stage and payload into geo-transfer orbit and the second stage provides the energy to put the payload into a circularized geo-sync orbit.

There were three incidents out of twenty four missions. Because of its ability to be commanded from the ground and being functionally redundant only one mission was lost. The three missions where there were incidents were: IUS-2, IUS-1, and IUS-21. Our experience was with IUS-1 and IUS-21, and only those will be discussed.

IUS-1 was flown on Space Shuttle STS-6 in 1983 and the payload was the Tracking and Data Relay Satellite (TDRS-1). During the IUS-1 second stage flight, a critical seal in the nozzle failed. The nozzle canted and locked up in the canted position and the control system lost its ability to position the nozzle and control the system. The IUS/TDRS tumbled for about half of the circularization burn and ended in a 13,579 by 21,980 statute mile orbit. While tumbling the IUS and TDRS were separated by ground command. Over a two month period the TDRS was boosted to the desired 22,300 mile orbit; it required thirty nine maneuvers and consumed 64% of the hydrazine fuel.

Shown on Figure 11-3 is a cross section of the second stage nozzle. Hot gas leaked through the Grafoil seal. The titanium housing of the Techroll seal got hot and the seal's casing lost its material properties and burst under pressure. The seal collapsed and the nozzle shifted down and canted. To fix this condition for succeeding flights, the tack bonding of the Grafoil seal was eliminated. In addition, the seal's density was increased along with removing the chamfer from its surfaces. [Chase, et. al., 1984]

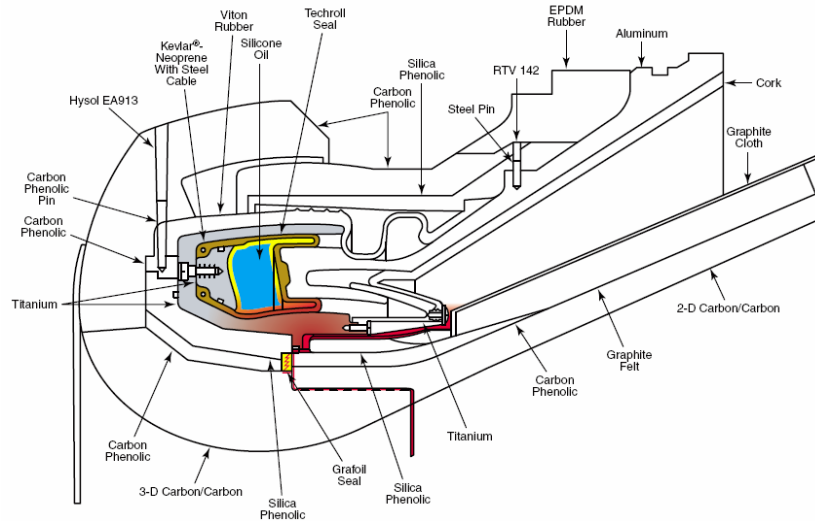

Figure 11-3. Cross Section of IUS Second Stage Nozzle

The next example pertains to IUS-21. It was flown on Titan IVB-27 in 1999 and the payload was Defense Support Program -19 (DPS-19). About six and a half hours after liftoff and when IUS was in the trans-geo flight the IUS initiated separation of the stages. The two stages did not fully separate and when the second stage fired the system tumbled into an unusable highly inclined elliptical Earth orbit. [Brinkley, et. al., 2008]

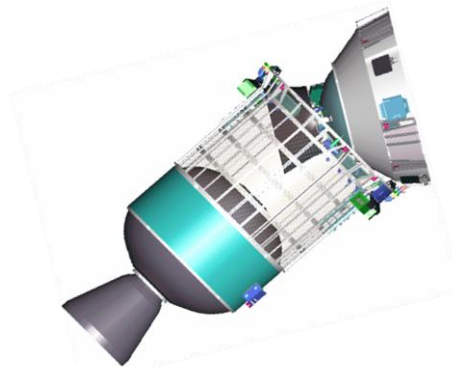

Figure 11-4. Sketch of IUS First and Second Stage

Shown in Figure 11-4 is a sketch of the two stages in the unseparated state before the second stage was fired. The failure was a result of an electrical connector plug/jack and harness not disconnecting, preventing the two stages from separating.

Investigation revealed that technicians wrapped thermal insulating tape too close to the connector preventing stage separation; see the left figure in Figure 11-5. Technicians applied the thermal wrap according to the 1978 detailed operations procedures (DOP). The

DOP omitted unique requirements relating to the separation function, instead stated the tape should be applied within 0.5 inches of the mounting bracket flange.

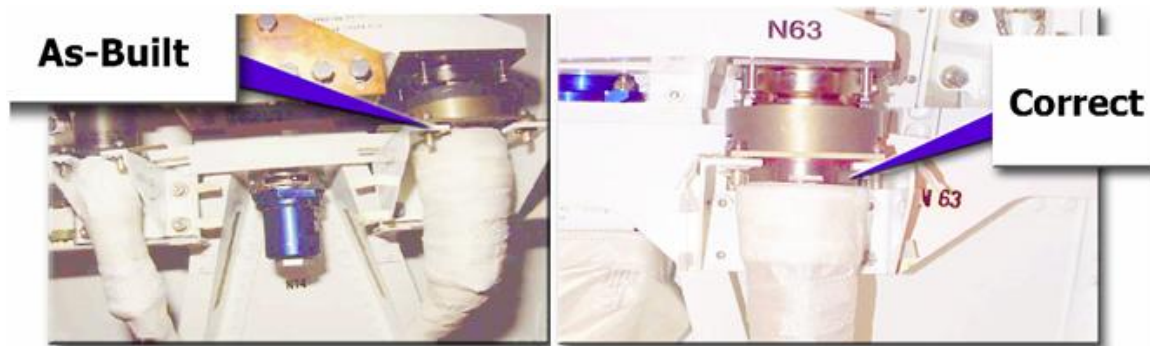

Figure 11-5. Electrical Harness as Built and Corrected

There was a change in the DOP that stated: apply the thermal wrap no closer than 0.5 inches and no further than 1.0 inches from the mounting bracket flange, see the right figure in Figure 11-5.

✦ **A key message from Lesson 11:**

Design for Robustness

- ***Make system insensitive to perturbations and/or make the response manageable***
- ***Stress simplicity in the design***

Lesson 12: Understanding Sensitivities and Uncertainties Is Mandatory

- ✦ **Determining system sensitivities leads to successful products.**
 - ▣ **Provides insights into design choices to achieve balance; (enables decision making)**
- ✦ **High performance systems have high sensitivities and uncertainties; this complicates the design process (no small changes)**
- ✦ **Incorporate appropriate philosophy and procedures for handling sensitivities and uncertainties throughout the process.**
 - ▣ **System sensitivities should be determined in conceptual design and evaluated throughout the design cycle**
 - ▣ **High sensitivities require more attention to design details; managing them leads to best design choices and reducing them reduces effects of uncertainties**

- ❏ **Uncertainties need to be determined for all inputs/outputs associated with system design**
- ❏ **Design must reduce uncertainties and provide appropriate margins**
- ❏ **In early phases of design, ensure that adequate margins are provided to cover the sensitivities and uncertainties of a specific vehicle, considering the immaturity of system definition**

Throughout the design of complex systems with high power densities numerous decisions are required to achieve the best balanced design. Sensitivity factor analyses provide insights in providing the best choices; thus enabling the best designs. For example, in the design of a liquid rocket vehicle system, the payload can be increased by increasing the engine specific impulse. Suppose a payload gain of 400 pounds could be achieved for a one second increase in engine specific impulse. Then for a 20 second increase in specific impulse, the payload would increase 8000 pounds. Thus the designer can decide how much to increase the specific impulse to achieve the payload requirement. In that decision process, the impact on engine design would have to be assessed along with other consequential interactive effects. In this example, the sensitivity factor would have been obtained through system performance analysis. In other situations, sensitivity factors can be also obtained through test or simulation

High performance systems have high sensitivities and uncertainties which complicates the design. If a comparison is made between the design efficiency (power/pound) of a rocket stage and an airplane, the rocket stage is about two orders of magnitude higher in design efficiency. If compared to an automobile, the rocket stage is about three orders of magnitude higher. In consideration of uncertainty, one of the complicating factors in designing a launch vehicle is the uncertainty in the atmospheric winds. To deal with this uncertainty, the winds on the day of launch are measured to verify that conditions are satisfactory to fly.

Sensitivities and uncertainties have to be determined and assessed through all stages of the design process. This requires attention to design detail to assess the best design decisions and potential for reducing uncertainty. In fact, uncertainty can in some cases be reduced by reducing sensitivities. Uncertainties can be determined from historical data bases, tests, and expert opinion. A major concern in design is determining the uncertainties in the output variables in terms of uncertainties in the input variables. Some of the methods used to assess uncertainty are root-sum-square (RSS) and Monte Carlo simulations.

In the early phases of design it is important to ensure adequate margins are provided to assure headroom for unknown effects of sensitivities and uncertainties. As the design activity proceeds every effort must be made to understand sensitivities to achieve the best balanced design and to reduce uncertainty to reduce risk and provide design confidence.

The following is an overview of uncertainty in rocket engine and structural design. In rocket engine design, high uncertainty results in high development cost. Figure 12-1 illustrates the effect of uncertainty on high cost. [Havskjold, 2004]. The figure on the left is the number of rework cycles (corrective actions) as a function of technical uncertainty factor for

various subsystems. As the uncertainty increases the number of rework cycles increases. The uncertainty is a result of high static and dynamic flow induced loads, thermal transients and gradients, high pump speeds, welds, etc. In the figure on the right is the cost versus the number of years in the development. It can be seen that 73% of the development cost is a result of corrective actions (test-fail-fix). In the development of the SSME there were 38 significant incidents that cost over \$30 million per incident.

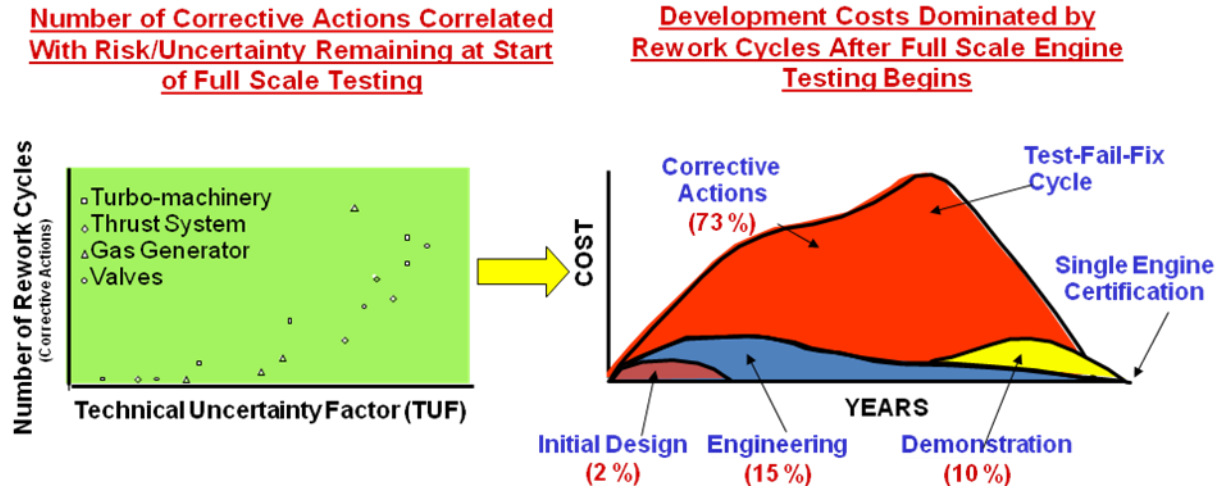

Figure 12-1. Technical Uncertainty Leads to High Cost

Having the experience shown in Figure 12-1, what can be learned to improve the effects of uncertainty? Shown in Figure 12-2 is an indication of how reducing uncertainty and improving processes can reduce development cost.

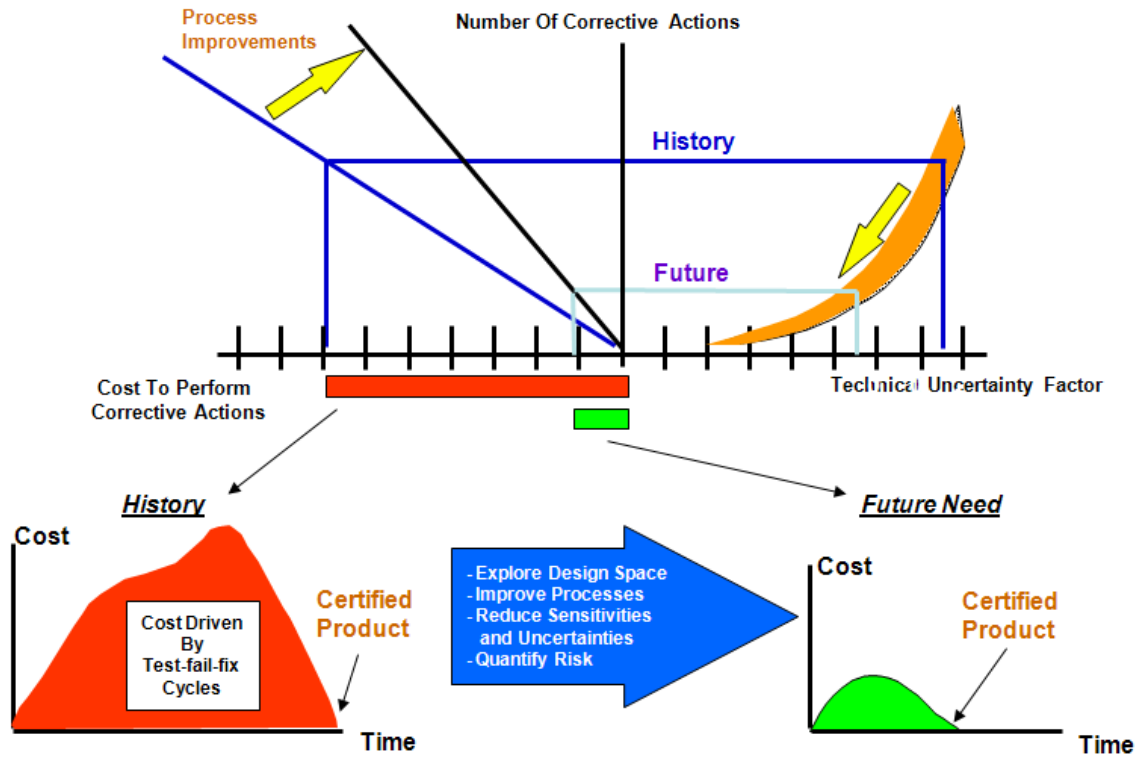

Figure 12-2. Combined Effect of Low Uncertainty and Improved Process to Reduce Cost

Figure 12-2 indicates that as the uncertainty is reduced the number of corrective actions can be reduced and by process improvements the cost of corrective actions can be improved. The net effect will be reduced cost to achieve a certified engine. Uncertainty can be reduced by lowering the static and dynamic flow induced loads, e.g. decrease chamber pressure and open up flow areas. In addition, uncertainty can be reduced by reducing pump speeds, improved definition of environments, etc. Process improvements can be achieved by minimizing welds, application of friction stir welding, bonding by high isostatic pressing, reduced part count, etc. Overall by building on our experience base as shown in Figure 12-2 and by implementing new design technologies, significant cost reductions can be expected in the future.

Uncertainty in structural design is illustrated in Figure 12-3. In the middle of the figure

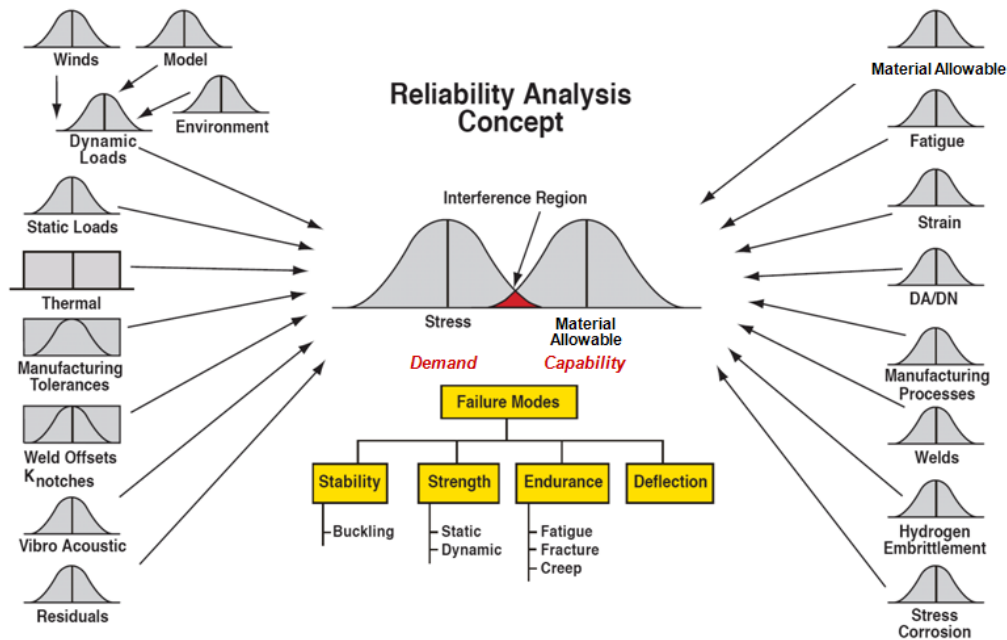

Figure 12-3. Uncertainty in Structural Design

are the probability density functions (PDF) of the working stress and the material allowable. In the region where there is overlap, failures will occur. In this example, the design has considered all the failure modes and the failure mode of concern is the strength. The variability in the material allowable can come from the random variations as characterized by the right-hand PDF's and for the stress the variability can come from the random variations associated with the PDF's in the left hand column. Knowing the associated PDF's, the reliability of the design can be determined. In the example shown, the design would be unacceptable because of the size of the interference region. Various changes can be made. The mean stress can be reduced by reducing the load or changing geometry. The uncertainty could be reduced by restricting the uncertainty in the load, changing tolerances, improving welding, etc. The material properties can be improved by changing the material to one that has a higher allowable or one with less uncertainty or both.

Sensitivity and uncertainty play important roles in the design of complex designs where there are high power densities. Sensitivities provide insights regarding developing the best balanced design and also aid in reducing uncertainties. Knowing the uncertainty provides a means for assessing risk and provides confidence in the design. Understanding past experiences (lessons learned) and applying new design tools provide visions toward design improvements to reduce cost in the future.

Examples:

- Saturn V Hold Down Post
- Space Shuttle Liftoff Loads
- Alternate Turbo Pump Vibration
- SAFE Solar Array Day-Night Frequency Shift

- Space Shuttle Parameter Uncertainties Matrix
- SRM Thrust Bucket and SSME Throttling (Lofting vs. Throttling)
- SRM Gimbaling Nozzle

Saturn V Hold Down Post (Liftoff Loads)

Safety requirements dictate that all liquid engines of the initial flight stage be at full power and healthy before releasing the vehicle from the launch pad. To meet this requirement the vehicle is attached to the launch pad with large mechanisms with sufficient strength to counteract the thrust force pad environments with margin. As a result the total thrust (7.5 million pounds) of the Saturn V first stage is stored in the structure as strain energy (potential energy). When the engines are all declared healthy the vehicle is released from the pad to fly into space. This release of energy creates a very large structural dynamic response of the vehicle and increases the loads significantly in the vehicle first stage with some increases in the loads in the other vehicle stages. These load increases would result in performance loss due to the structural weight increase required to handle the loads. As a result a soft release was employed as illustrated on Figure 12-4. It consisted of a tapered bolt that was severed using a pyrotechnic device. The tapered bolt was then pulled through the smaller diameter skirt attachment hole, slowly releasing the energy and decreasing the loads by approximately 30%. Summarizing:

- Engines are started and are at full thrust in order to assure engine health, before releasing the vehicle from the launch facility.
- Engine thrust energy is stored in the thrust frame and other vehicle structures.
- The stored energy, that is suddenly released, creates a large dynamic response.
- Saturn V used a soft release mechanism in order to reduce the dynamic response (loads).
- The release was an extruding bolt through an orifice as shown on the next figure.
- Loads in the rear of the vehicle were reduced more than 30%.

Saturn V Holddown Post

Soft Release Mechanism

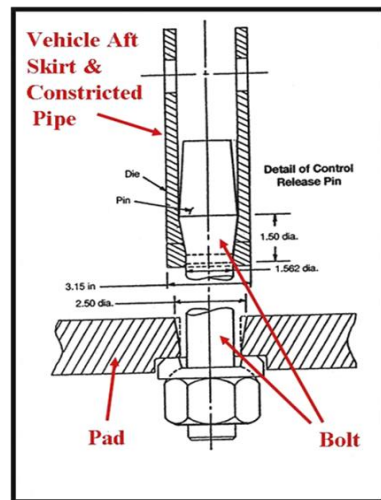

Soft release is achieved by the pad hold-down bolt being pulled through a constricted pipe attached to the aft skirt. The bolt stayed attached to the launch pad.

Figure 12-4. Saturn V Hold Down Post Soft Release Mechanism

Space Shuttle Liftoff Loads

Space Shuttle had the same requirement as Saturn V with a much more complex dynamic system and with a very sensitive performance issue. Therefore it was mandatory that structural mass be as minimum as possible. The Shuttle is a five body system connected with interfaces called struts and/or attachment mechanisms. The vehicle is unsymmetrical in the pitch plane with the orbiter attached on the side of the External Tank and Solid Rocket Motors. The vehicle is held to the Mobile Launch Pad (MLP) with four pyrotechnic bolts on each solid. See the following figure. The vehicle is first filled with the cryogenic liquid propellants which shrinks the External Tank longitudinal and in diameter. For example the aft SRB to ET attachment strut is at 7 degrees to perpendicular before filling the tank and becomes perpendicular due to the cryogenic shrinkage when the tanks are filled. In addition its diameter shrinks approximately 2 inches. This stores energy into the structure. At the start of the on pad liftoff cycle the SSME's are ignited and carried to 90% thrust to ensure engine health. The engines are canted for c.g. tracking and are offset from the vehicle center line several feet. This stores additional energy in the structure in two ways. The orbiter is lifted up bending the vehicle over the attached points introducing a large bending moment in the system. This can be illustrated visually by watching the launch of Shuttle observing the tank tip moving laterally approximately 36 inches. This sets up a dynamic motion of the vehicle on the pad about the mean moment introduced by the SSME thrust. Since the engines are offset, they also push the Orbiter and ET between the two motors that are holding the vehicle to the pad. [Ryan, 1996]

At SRB bolt release all this stored energy is released creating a large complex dynamic response. The interaction of the four vehicle bodies plus the payload body requires approximately 300 bending modes to simulate the response and calculated all the system

loads. At release two additional forces add to these dynamic responses, thus loads. These are the expansion of the Solid Rocket Motor due to the 960 psi of internal pressure created by the burning propellant. This pressure goes from zero to the 960 psi in 500 milliseconds after motor ignition. The ignition of the motors and the large thrust created moves through the launch pad thrust tunnel creating an overpressure wave that travels up the vehicle. Since the Shuttle is a 1½ stage vehicle it is very performance critical, thus these high dynamic loads had to be mitigated to reduce structural weight.

As stated above the SSME thrust at engine start and buildup creates a dynamic motion laterally as shown on Figure 12-5. The vehicle motion of moving back to a minimum position has a minimum energy point at which time if the vehicle is released from the pad will have the lowest load. Shown as stored bending moment on Figure 12-6 is the time dependency of the bending moment. As a result it was decided to burn the SSME's 2½ seconds beyond the point where they are declared healthy, greatly reducing the loads. This delay of liftoff from the time of verified SSME's to the minimum energy point reduces vehicle performance but at a much lower level than would be the impact of the increased loads. Figure 12-7 is a plot of the predicted liftoff response versus a flight response.

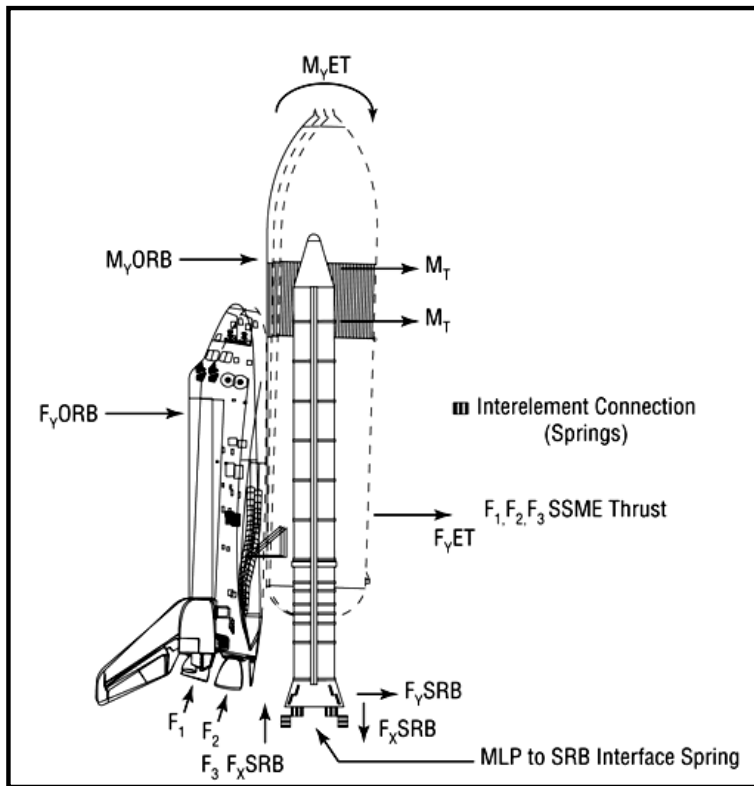
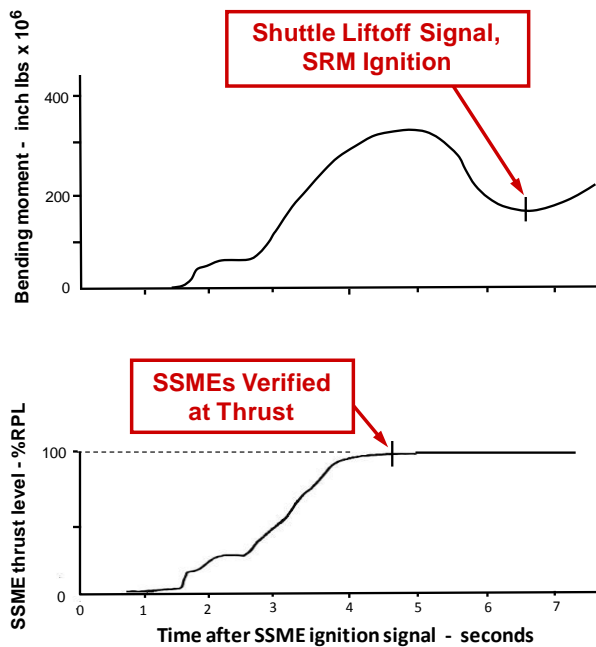

Figure 12-5. Shuttle Liftoff Dynamics



- The bottom figure shows the SSME thrust history.
- The top figure shows the bending moment stored in the vehicle as a function of time after SSME's ignition.
- SRM ignition and liftoff is deferred about 2 seconds until the bending moment is minimum.

Figure 12-6. Shuttle Liftoff Timing

In Figure 12-7 one can see the stored load and the minimum energy release point followed by the large dynamic response discussed above. The plot is for the ET to SRB strut load response. The difference in prediction versus flight is explained by the fact that the prediction was for 3-sigma conditions while the flight was near nominal conditions.

Shuttle Liftoff ET-to-SRB Strut Load Response

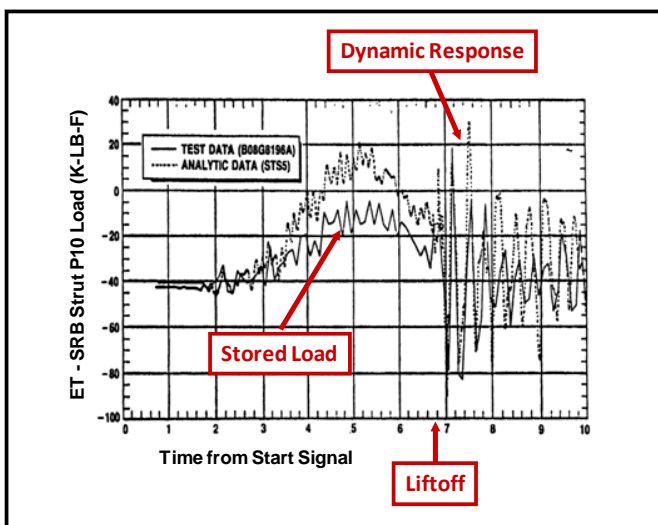

- The stored energy is shown from 0 to 7 seconds.
- The dynamic response is shown from 7 to 10 seconds.
- The magnitude and complexity of the response varies with vehicle location.

Figure 12-7. Shuttle Liftoff Loads

These two examples show how the uncertainty and sensitivities of a system were understood, resulting in a better performing system.

In summary:

- Space Shuttle, due to its asymmetrical configuration, stores energy as the SSME's thrust lifts the Orbiter and pushes the Orbiter and External Tank between the SRB's.
- The energy is stored by deflecting the External Tank (36" at the tip) and twisting the SRB's pad attach hardware.
- The liftoff response is very dynamic and sensitive. Loads can change 30% with small changes in the configuration or its operating parameters.
- The liftoff signal is delayed approximately 2 seconds in order to have the system at a minimum stored engine condition.
- The liftoff delay cost approximately 1,000 lbs of payload, which was less than the payload impact of designing to the unmitigated load.
- The loads sensitivity at liftoff requires loads analysis and verification for each launch/payload. The consequence is *operational complexity*.

Alternate LOX Turbopump Vibration Problem

The SSME did a block upgrade on the high pressure turbopumps to eliminate most of the fracture and fatigue problems associated with the original turbopumps. These new pumps were called ATD pumps (Alternate Turbopump Development pumps). During development test of the ATD LOX turbopump, the pump experienced large synchronous vibrations which would shut the test down. The following plot and pump schematic (Figure 12-8) shows response that would nearly instantaneously increase to a high level shutting down the test. The solution turned out to be the bearing dead band after much effort had been expended on trying to decrease the hydrodynamic forcing function. The pump response was so sensitive that changing the dead band 2 mils (two thousandths of an inch—less than the thickness of a sheet of paper) would stop the vibration, while reversing it would reinstate the problem. This placed a strict manufacturing tolerance on assembling the pump. Through understanding this sensitivity, the pump has not had any vibration problem over many Shuttle flights. [Problem solution team working notes and Ryan et al, 1994]

ATD Synchronous Vibration Fix Summary

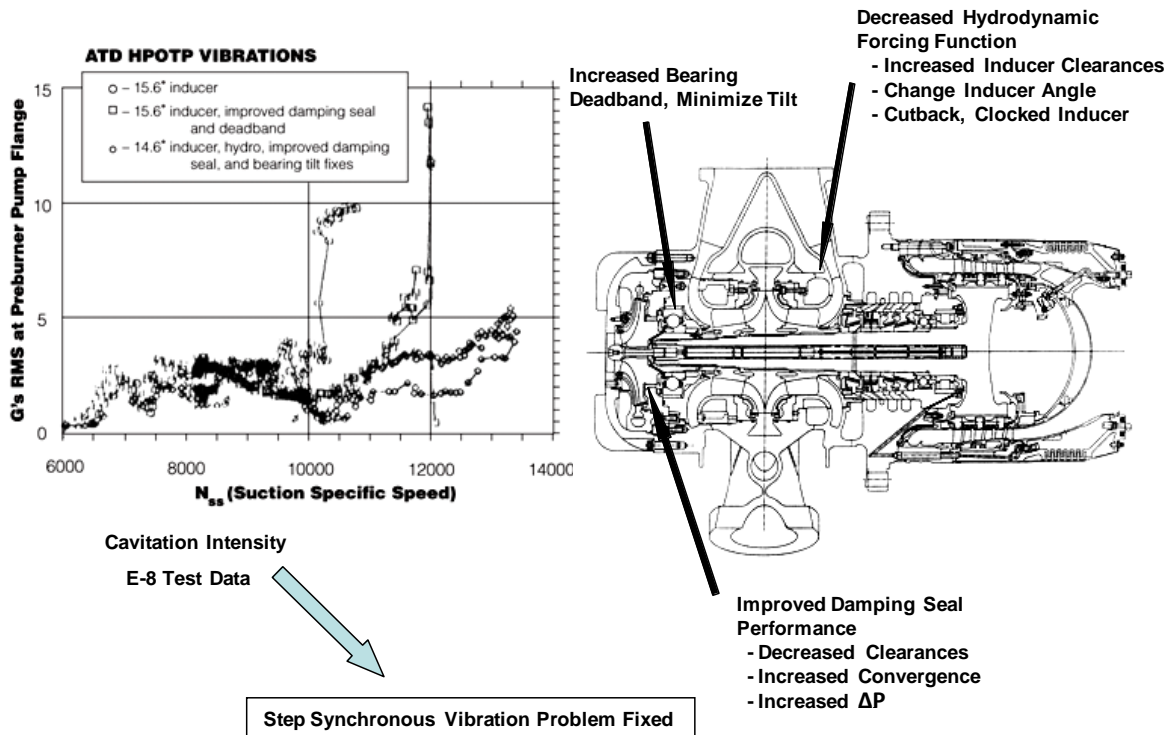

Figure 12-8. Alternate LOX Turbopump Vibration Fix Summary

Solar Array Flight Experiment (SAFE) Day-Night Frequency Shift

The solar array flight experiment had two objectives: (1) Develop a method for dynamic testing of large space structures in space, (2) Evaluate the effectiveness of a new design for solar power. See Figure 12-9, showing the solar array extended out of the Shuttle cargo bay. During the experiment a shift occurred in the natural frequency of the array when going from night to day during the orbit; this was not predicted. The reason for the shift was the thermal induced contraction and expansion of the array changing its moment of inertia. This can be seen in Figure 12-10 as a cupping of the array during the night portion of the orbit. Although thermal effects on structure are well known it was not expected to have much effect on this large a structure. Again the lessons keep repeating themselves; understand and quantify sensitivities. The experiment was very successful showing that dynamic testing of large structures in space was feasible. [Schock, et al, 1986]

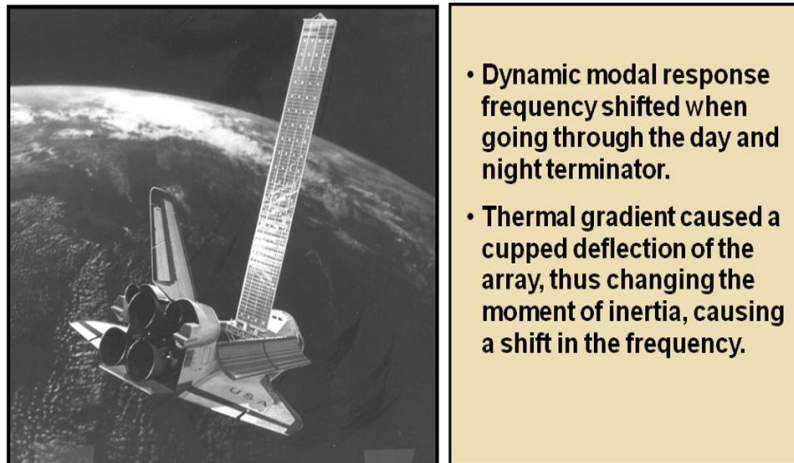

Figure 12-9. Artist's Conception of the SAFE Solar Array Experiment On Orbit

SAFE Solar Array Frequency Shift

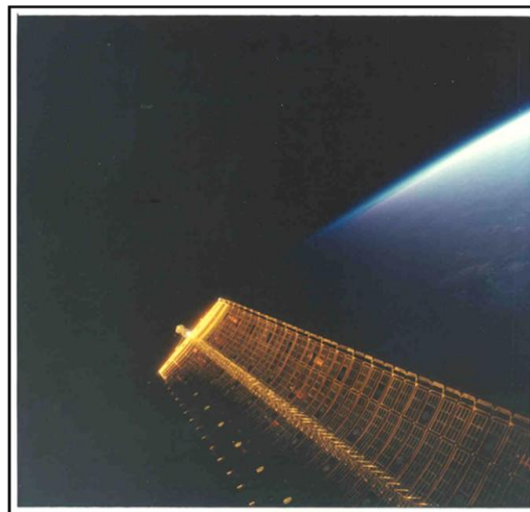

Figure 12-10. Picture of Deployed SAFE Solar Array Made from Space Shuttle

Space Shuttle Parameter Uncertainties Matrix

In the early days of Shuttle design it became very clear that the sensitivities of the Shuttle system to parameter uncertainties required a concerted effort to define all the parameter uncertainties that affected the vehicle induced environments, etc. This was a concerted effort coordinated by the Ascent Flight Integration Working Group (AFSIG). It took approximately two months to complete the initial version. The uncertainty levels were burned down as the program progressed and more data was collected from test and flights. The lesson is clear;

each project must develop and put under control all parameter uncertainties and continue to burn them down throughout the lifecycle. The guidelines for development of this data follows:

- In order to achieve a balanced design for Space Shuttle, the vehicle driving parameters required determining their mean values and their 3 sigma variations.
- These variations had to be established for each mission event and each major design function.

Figure 12-11 shows a partial listing of the parameter variations, illustrating the format and the magnitude of the task. This compilation was a large document that was placed under configuration control.

Example Table from Extensive Parameter Matrix

| | | | | |
|---|---|--------------------|--|---|
| <small>ED5154</small> ORGANIZATION SYSTEMS DYNAMICS LABORATORY | MARSHALL SPACE FLIGHT CENTER BASIC PARAMETERS (CONTINUED) | NAME R. RYAN | | |
| CHART NO. 17 | | DATE APRIL 1986 | | |
| <table style="width: 100%; border: none;"> <tr> <td style="width: 60%; vertical-align: top;"> <u>MAIN PROPULSION SYSTEM</u> <ul style="list-style-type: none"> ● 3 SSME THRUST LEVEL THROTTLING RANGE ● THRUST OSCILLATION (DYNAMIC FACTOR ASSUMED ONLY FOR LOADS ANALYSIS) ● EQUAL THROTTLE SETTINGS ON ALL SSME'S ● WITH ONE SSME OUT, THE TWO REMAINING SSME'S OPERATE AT 109% THRUST ● THRUST MISALIGNMENT ● MIXTURE RATIO (6:1) ● VARIATIONS IN ET PROPELLANT LOAD LEFT AT MECO RESULT FROM OFF-NOMINAL SRM/SSME PERFORMANCE AND SSME THROTTLING HISTORY <u>MASS PROPERTIES</u> <ul style="list-style-type: none"> ● MINIMUM PAYLOAD OF 2,500 LBS. (MISSION 3B) ● MAXIMUM PAYLOAD OF 32,000 LBS. (MISSION 3A) ● MAXIMUM PAYLOAD OF 65,000 LBS. (MISSION 1) <u>FLIGHT CONTROL AND GUIDANCE</u> <ul style="list-style-type: none"> ● ROCKWELL CONTROL # 7 PER SD73-SH-0097-1 (INTEGRATED VEHICLE FLIGHT CONTROL SYSTEM DATA BOOK) ● ELEVON SCHEDULE # 6 (HINGE MOMENT LIMITING FEEDBACK) ● PLATFORM MISALIGNMENT ● ACCELEROMETER MISALIGNMENT ● ACCELEROMETER NULL OFFSET (TIME VARIABLE) ● ACCELEROMETER MDM BIAS ● IMU ATTITUDE ERROR ● ACTUATOR HYSTERESIS ● RATE GYRO MISALIGNMENT </td> <td style="width: 40%; vertical-align: top; padding-left: 20px;"> <u>ANALYSIS TOLERANCE</u> <ul style="list-style-type: none"> 50% (IMPL) TO 100% (FPL) ± 5% NONE NONE ± 0.3° PER SSME NONE NONE NONE NONE NONE NONE NONE NONE NONE NONE ± 0.02 HINGE MOMENT COEFFICIENT ± 0.5° ± 0.5° 0.010 TO 0.025 g (PITCH) 0.008 TO 0.015 g (YAW) 0.0248 ± 0.0083° 1.5 MA ± 2° </td> </tr> </table> | | | <u>MAIN PROPULSION SYSTEM</u> <ul style="list-style-type: none"> ● 3 SSME THRUST LEVEL THROTTLING RANGE ● THRUST OSCILLATION (DYNAMIC FACTOR ASSUMED ONLY FOR LOADS ANALYSIS) ● EQUAL THROTTLE SETTINGS ON ALL SSME'S ● WITH ONE SSME OUT, THE TWO REMAINING SSME'S OPERATE AT 109% THRUST ● THRUST MISALIGNMENT ● MIXTURE RATIO (6:1) ● VARIATIONS IN ET PROPELLANT LOAD LEFT AT MECO RESULT FROM OFF-NOMINAL SRM/SSME PERFORMANCE AND SSME THROTTLING HISTORY <u>MASS PROPERTIES</u> <ul style="list-style-type: none"> ● MINIMUM PAYLOAD OF 2,500 LBS. (MISSION 3B) ● MAXIMUM PAYLOAD OF 32,000 LBS. (MISSION 3A) ● MAXIMUM PAYLOAD OF 65,000 LBS. (MISSION 1) <u>FLIGHT CONTROL AND GUIDANCE</u> <ul style="list-style-type: none"> ● ROCKWELL CONTROL # 7 PER SD73-SH-0097-1 (INTEGRATED VEHICLE FLIGHT CONTROL SYSTEM DATA BOOK) ● ELEVON SCHEDULE # 6 (HINGE MOMENT LIMITING FEEDBACK) ● PLATFORM MISALIGNMENT ● ACCELEROMETER MISALIGNMENT ● ACCELEROMETER NULL OFFSET (TIME VARIABLE) ● ACCELEROMETER MDM BIAS ● IMU ATTITUDE ERROR ● ACTUATOR HYSTERESIS ● RATE GYRO MISALIGNMENT | <u>ANALYSIS TOLERANCE</u> <ul style="list-style-type: none"> 50% (IMPL) TO 100% (FPL) ± 5% NONE NONE ± 0.3° PER SSME NONE NONE NONE NONE NONE NONE NONE NONE NONE NONE ± 0.02 HINGE MOMENT COEFFICIENT ± 0.5° ± 0.5° 0.010 TO 0.025 g (PITCH) 0.008 TO 0.015 g (YAW) 0.0248 ± 0.0083° 1.5 MA ± 2° |
| <u>MAIN PROPULSION SYSTEM</u> <ul style="list-style-type: none"> ● 3 SSME THRUST LEVEL THROTTLING RANGE ● THRUST OSCILLATION (DYNAMIC FACTOR ASSUMED ONLY FOR LOADS ANALYSIS) ● EQUAL THROTTLE SETTINGS ON ALL SSME'S ● WITH ONE SSME OUT, THE TWO REMAINING SSME'S OPERATE AT 109% THRUST ● THRUST MISALIGNMENT ● MIXTURE RATIO (6:1) ● VARIATIONS IN ET PROPELLANT LOAD LEFT AT MECO RESULT FROM OFF-NOMINAL SRM/SSME PERFORMANCE AND SSME THROTTLING HISTORY <u>MASS PROPERTIES</u> <ul style="list-style-type: none"> ● MINIMUM PAYLOAD OF 2,500 LBS. (MISSION 3B) ● MAXIMUM PAYLOAD OF 32,000 LBS. (MISSION 3A) ● MAXIMUM PAYLOAD OF 65,000 LBS. (MISSION 1) <u>FLIGHT CONTROL AND GUIDANCE</u> <ul style="list-style-type: none"> ● ROCKWELL CONTROL # 7 PER SD73-SH-0097-1 (INTEGRATED VEHICLE FLIGHT CONTROL SYSTEM DATA BOOK) ● ELEVON SCHEDULE # 6 (HINGE MOMENT LIMITING FEEDBACK) ● PLATFORM MISALIGNMENT ● ACCELEROMETER MISALIGNMENT ● ACCELEROMETER NULL OFFSET (TIME VARIABLE) ● ACCELEROMETER MDM BIAS ● IMU ATTITUDE ERROR ● ACTUATOR HYSTERESIS ● RATE GYRO MISALIGNMENT | <u>ANALYSIS TOLERANCE</u> <ul style="list-style-type: none"> 50% (IMPL) TO 100% (FPL) ± 5% NONE NONE ± 0.3° PER SSME NONE NONE NONE NONE NONE NONE NONE NONE NONE NONE ± 0.02 HINGE MOMENT COEFFICIENT ± 0.5° ± 0.5° 0.010 TO 0.025 g (PITCH) 0.008 TO 0.015 g (YAW) 0.0248 ± 0.0083° 1.5 MA ± 2° | | | |

Figure 12-11. Partial Listing of Shuttle Parameter Variation Matrix

SRM Thrust Bucket and SSME Throttling (Lofting vs. Throttling)

Constraints on space system designs are necessary; however, they always cost the system in terms of flexibility, performance, and programmatic. The Space Shuttle dynamic

pressure constraint at max q is a good example. The constraint was necessary for the elimination of buffeting of the Orbiter tail section and to keep induced environments such as loads within bounds. The vehicle performance is very sensitive to the constraints of controlling dynamic pressure and staying within the longitudinal acceleration limit of 3.15 g's. The following listing shows the sensitivities and general characteristics. In general reducing q by 1 psf by throttling is a loss of 25 pounds of payload while lofting cost 250 pounds of payload for a 1 psf reduction. In order to implement these constraints the SSME has to throttle to the minimum possible which is determined by the dynamic loads in the nozzle as thrust is lowered. This is a result of the requirement that the nozzle shape be optimized for operation from ground to vacuum and is a compromise of the nozzle instability versus maximum performance in vacuum. The SRM grain had to be shaped such that there was also a SRM thrust reduction during Max q . Finally an adaptive guidance scheme for SSME throttling was instituted to obtain increased vehicle performance as compared with a predetermined SSME throttling profile. [Ryan, 1996] Just remember "*Constraints Cost.*"

Dynamic Pressure Constraint (Lofting vs Throttling)

- SSME throttles to maintain the longitudinal acceleration at 3.15 g's and to keep the dynamic pressure (q) within the 650 psf nominal limit.
- During atmospheric flight SSME cannot throttle below 65% full thrust due to the nozzle side loads.
- The 65% limit means that lofting must be used in conjunction with throttling to maintain q within 650 psf.
- The penalty for lofting is approximately 250 lbs payload loss for each 1 psf q reduction, while the penalty for throttling is 25 lbs payload loss for each 1 psf q reduction.
- Dynamic pressure limits can be traded for structural weight.

SRM Gimbaling Nozzle

In the early phases of Shuttle design, it was hoped that gimbaling the three main engines on the Orbiter would provide sufficient controllability during ascent flight. Therefore, the initial design had fixed nozzles on the Solid Rocket Motors (SRM's). As more information was obtained on SRM characteristics and other parameter variations, it became apparent the vehicle would not be controllable by the main engines alone due to uncertainties in SRM thrust direction and other perturbations. Thrust vectoring capability had to be added to the SRM's, as indicated in Figure 12-12. [Ryan, 1996]

- Because of uncertainties in SRM thrust direction and other parameters, Space Shuttle was not controllable without thrust vectoring on the Solid Rocket Motors.
- Vectoring the thrust on solids is a major design problem.
- A flex bearing and seal was required. This bearing/seal is made of eleven rubber/steel laminations.
- Moving the nozzle (thrust vectoring) requires large actuator forces due to the stiffness of the flex bearing/seal.

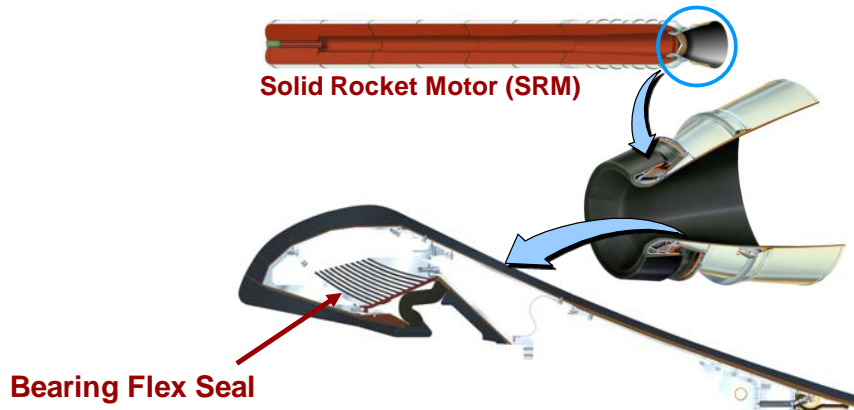

Figure 12-12. Solid Rocket Motor Gimbaling Nozzle

This was a major impact to the SRM design and the total Shuttle vehicle. Vectoring a solid rocket motor nozzle greatly increases its complexity. The approach taken was to use a flex bearing and seal made of eleven rubber/steel laminations. Moving the nozzle to vector the thrust requires large actuator forces to overcome the high stiffness of the flex bearing and seal, plus other loads such as aerodynamic forces. Actuator deflections, rates, and accelerations must be adequate for controllability and control stability. In turn, large actuator forces require high output hydraulic power supplies in the aft skirts, along with the attendant complexities of handling hazardous fuels. So an inherent uncertainty in the system led to major operational and cost impacts.

Here again we are dealing with uncertainties and sensitivities that must be understood, quantified and ameliorated or the design will not work. Not only must these be understood and managed, but also the derived requirements flowing from uncertainties and sensitivities often are design drivers that must be accurately determined.

✦ **A key message from Lesson 12 is:**

Quantifying sensitivities, uncertainties, and margins enables balancing risk.

To ignore system sensitivities and uncertainties is a recipe for failure.

***Quantify
Understand
Manage***

In the next lesson we will apply the understanding of sensitivities and uncertainties as a measure for the requirements of a system to have margins in the design.

Lesson 13: Program Margins Must Be Adequate

- ✦ **Margins must be adequate to cover anticipated growth during design, TRL immaturity, and sensitivities. Otherwise, many design problems, overruns, and reduced performance will occur.**

We have just discussed the importance of understanding of sensitivities and uncertainties. This understanding is one of the main drivers for intelligently adding margins of the system in addition to providing means of covering uncertainties and unknowns that are always present in a system. The following lesson, Margins must be adequate, will deal with Space Shuttle lack of margins and techniques to recover the induced performance losses and the SSME pump bearing corrosion issue.

Examples:

- Space Shuttle Performance Margins
- SSME LOX Pump Bearing Race Failure

Space Shuttle Performance Margins

During the Space Shuttle design process and first test flights the lack of margins and the solution to encountered problems resulted in an approximate 45,000 pound payload performance deficit for the Air Force mission. Many of these issues were seen during the design cycle that resulted in numerous weight reduction strategies and planned block changes to the Shuttle elements such as SRM, ET, SSME and Orbiter. The solutions also resulted in many operational procedures and constraints. An example is structural loads that require a Day of Launch I-Load update based on wind measurements made 4 hours prior to launch. The following listing shows these modifications that were baselined to recover the payload losses and solve other problems.

Increase Performance of Propulsion System

- SSME @ 104% thrust design operating point and later upgrade to ATD Pump
- Large Throat, and Two-duct Manifold

Weight Reduction Program

- Light Weight Tank and later upgrade to Super Light Weight Tank
- Orbiter weight reduction
- High performance SRM
- Reduced wind criteria
- Flight derived dispersions

Operational Problems

- Additional maintenance, refurbishment, and inspection
- Additional day of launch analysis / constraints
- Additional day of launch operations

Details will be shown in Lesson 15

Many of these solutions created other problems; for example, the SSME thrust increase created increases in dynamic environments in the engine which resulted in many fracture and fatigue issues that had to be resolved with engine component block upgrades. Part of the original solution also resulted in giving up some of the launch availability to reduce loads. Not only did the program accomplish upgrades, but a major effort was made to take conservatism out of criteria, environments and design parameters.

SSME LOX Pump Bearing Race Failure

After Mission STS-27, post-flight inspection of the SSME LOX Pump found that the inner race of the turbine-end bearing had cracked through. Fractography showed that the crack had occurred before engine start, indicating that the engine had run its full duration with a cracked bearing race in the presence of liquid oxygen. This very hazardous situation was not revealed until the post-flight hardware inspection. Location of the turbine-end bearing is highlighted in the circled area of the turbopump cross-section on Figure 13-1.

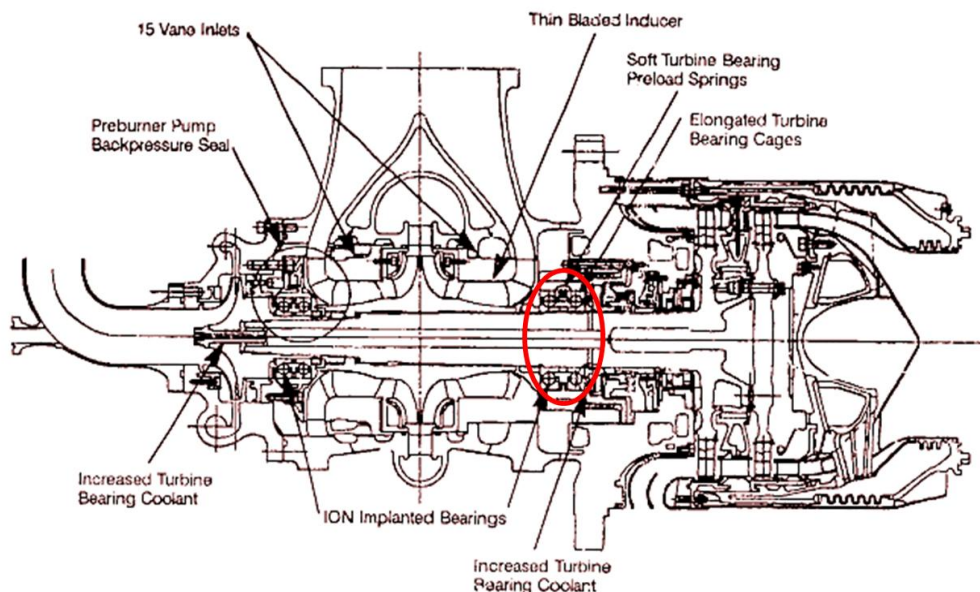

Figure 13-1. SSME LOX Pump Cross-Section Highlighting Bearing Location

The cause of the fracture was determined to be stress corrosion in a high stress condition. During assembly, the shaft is cooled with liquid nitrogen to achieve an interference fit of the bearing onto the shaft. The resulting residual hoop stress in the presence of water that condensed during assembly led to the fracture. Also, there was potential contamination from the Freon cleaning solution.

The hoop stress caused by the interference fit was 30 ksi or greater, which was excessive for the inner race material. To gain adequate margin, the design was adjusted to limit the hoop stress to 24ksi, and the contamination and condensation issues in the assembly clean room were addressed. This solved the stress corrosion cracking problem. Also, in some later applications for the Advanced Turbopumps, the race material was changed to a stronger material, which gained additional margin.

✦ **A key message from Lesson 13 is:**

Allocate adequate technical and programmatic margins or you will pay for it later.

Principle VI: Project Success is Determined by Life Cycle Considerations

This principle recognizes the importance of life cycle issues—its effect on design choices available, the large role that concept selection plays, recognition of how requirements have far-reaching, sometimes unintended consequences, and the need to achieve the best design for the entire life cycle.

Four lessons will be discussed:

- 14. The Design Space is Constrained Based on Where You Are in the Life Cycle**
- 15. Concept Selection and Design Process**
- 16. Requirements Drive the Design**
- 17. Design for the –ilities and Cost**

Lesson 14: The Design Space is Constrained Based on Where You Are in the Life Cycle

✦ **Three Life-Cycle Categories**

▣ **Conceptual/Initial Design**

- **Open design space for choices and trades**

☒ **Detail Design**

- **Design space constrained by concept choice**

☒ **Verification/Operations**

- **Design space constrained by the as-built system**
- **Must make system work. Solution options limited**

As we proceed through the system's life cycle, the range of choices available to affect the design and its operation become more constrained. Consider three timeframes within the life cycle: (1) at Conceptual/Initial Design, (2) at Detail Design, and (3) at Verification/Operations. At Conceptual/Initial Design, the design space is open, allowing essentially free choice of design variables to meet the mission requirements. By the time of Detail Design, the concept has been selected and preliminary design decisions have been made. This severely limits the freedom of the designer to choose variables. The majority of the system performance and cost attributes are determined by the concept that has been selected, as will be addressed in Lesson 15. Once the system has been manufactured, at the time frame of Verification or Operations, the design space is constrained by the as-built system. Unless there is to be a major redesign cycle, the system must then be made to work by minor adjustments or by operational constraints. Solution options are very limited at this point. It is clear that early choices have a major constraining effect on the range of downstream choices that can be made.

Examples:

- International Space Station Rack Design
- Replacement of SSME Baseline Turbopumps with Alternate Design Turbopumps

International Space Station Rack Design

In designing the International Space Station (ISS) science racks (Figure 14-1), four issues were paramount. (1) The racks needed to be lightweight. (2) Flexibility in mounting and operating various experiments was desired. (3) Because some of the experiments would need a low-gravity environment, the presence of crew motion and other disturbances meant that a vibration-isolation system should be incorporated into the racks. (4) The racks had to be sufficiently stiff to meet minimum frequency requirements as a Shuttle payload, to avoid dynamics and loads problems during launch. [Bookout, 1996]

- ✦ **Four issues were paramount in the design of the ISS Science Racks**
 - **Weight reduction**
 - **Experiment operations and mounting flexibility in rack**
 - **Vibration isolation at zero g**
 - **Meeting Shuttle frequency requirements**

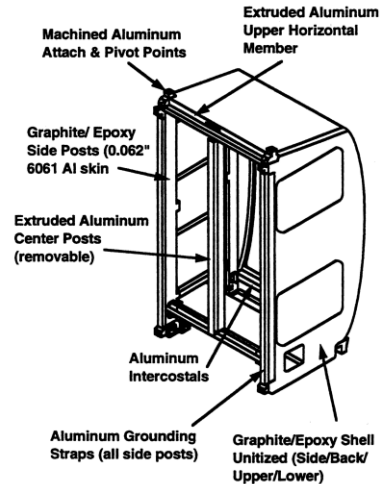

Constraints create unwanted compromises of a design.

Figure 14-1. ISS Science Rack Design

Initial consideration of the design requirements and constraints led to a choice of composite material as a means of saving weight and achieving acceptable stiffness; however, when all the constraints, requirements, and accommodations were met, the weight saving of composites as compared to aluminum was not realized. It would have been simpler and less expensive to have gone with metal construction from the start.

Also, design of the active vibration isolation system was difficult because of geometric constraints in addition to the other constraints and requirements listed above. It is clear that constraints create unwanted compromises of a design.

Another aspect of ISS rack design related to the need to use the racks for many different functions. A number of them are illustrated in Figure 14-2. Granting the flexibility of a single design to accomplish all these functions created design and verification problems. However, in general, the advantage of commonality outweighed the design issues.

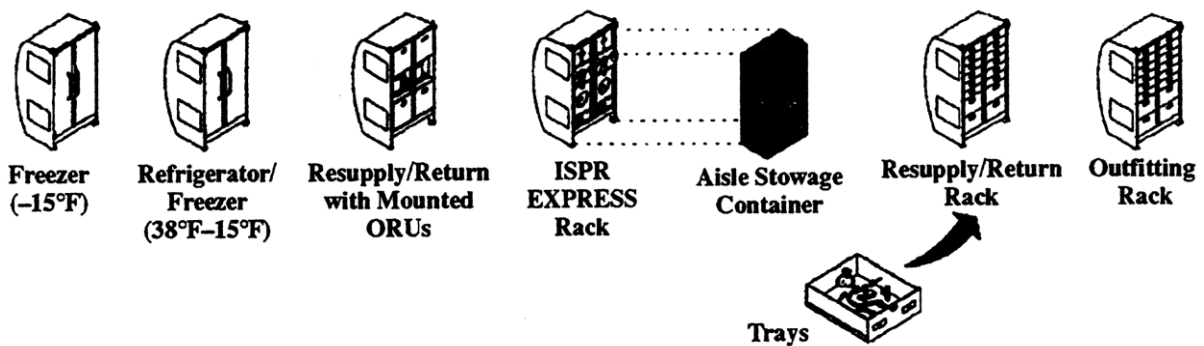

Flexibility and commonality are very desirable for operations, but can create many design issues and challenges.

Figure 14-2. ISS Rack Functions and Configurations

The Space Shuttle Orbiter configuration is another example of this issue. The Shuttle was developed to a multi-agency set of requirements from both NASA and the Department of Defense. Military requirements dictated larger payloads and greater reentry cross-range than did NASA's requirements. DoD required a 1500 nautical mile cross-range to enable landing at the launch site after a once-around delivery orbit. NASA's cross-range requirement was less, being dictated by abort considerations. There were two competing Orbiter configurations: a delta-wing design needed to produce sufficient hypersonic lift/drag ratio to achieve the DoD cross-range requirement, and a simpler straight-wing design that could satisfy the NASA requirement. Because the vehicle design had to envelope both requirements, a delta wing was chosen.

Obviously, there is no way of determining how a matured straight wing design would have performed, although predictions at the time indicated it would have a simpler thermal protection system and a less-demanding landing system. Because of subsequent developments, the DoD never made use of the Orbiter's cross-range capability, but the Shuttle program has continued to pay the operational costs associated with the delta wing configuration and its thermal protection system.

Flexibility and commonality are desirable goals, but they usually constrain the design space and can create design issues and challenges. Early in the project, make sure that commonality requirements are indeed firm, and that their downstream implications are understood.

Replacement of SSME Baseline Turbopumps with Alternate Design Turbopumps

The replacement of the original Rocketdyne turbopumps by the Pratt and Whitney alternate turbopumps (Figure 14-3) drew on lessons learned from the original pumps to improve reliability and maintainability. The weight allowance for the alternate pumps was increased over that for the original pumps. The increased weight allowance accommodated

significant improvements in turbopump design and reliability; however, the alternate pump designs had to interface with the existing engine system, including the powerhead and ducts. Geometric, pressure, and thermal interfaces had to be matched while meeting weight requirements. Because of these constraints, the alternate pumps couldn't make full use of the lessons learned and produce a fully optimized design.

- ✦ The P&W Alternate High Pressure Turbopumps were designed using lessons learned from the Rocketdyne pumps.
- ✦ Full advantage of the lessons could not be utilized since the pumps must be compatible with the existing engine powerheads, ducts, etc.
- ✦ These constraints were:
 - Geometric
 - Pressure
 - Thermal
 - Weight

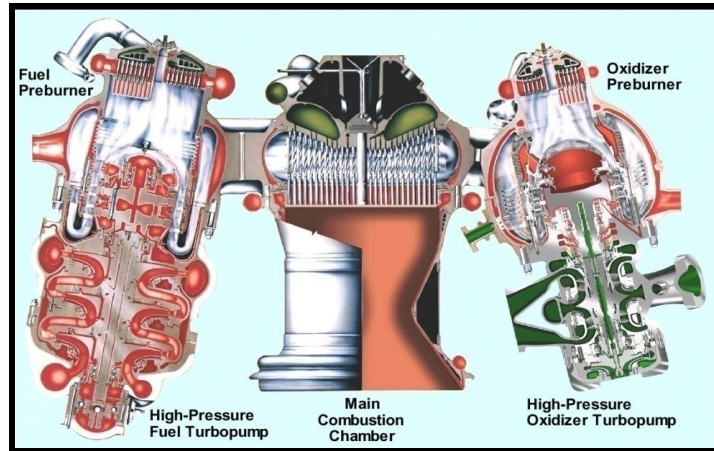

Constraints required to use a new component in an existing system in general lead to a non-optimal design and higher costs.

Figure 14-3. Alternate High Pressure Turbopumps

In general, interfacing constraints required to use a new component in an existing system lead to a non-optimal design and higher costs.

So, the lesson is to recognize life cycle effects on the design space. As we progress through the design process, fidelity increases and uncertainty decreases, but the design choices decrease. Minimize constraints to increase design opportunities.

- ✦ **A key message from Lesson 14 is:**

Recognize Life Cycle Effects on the Design Space

- ***Fidelity increases***
- ***Uncertainty reduces***

but

- ***Design choices decrease***

Minimize Constraints to Increase Design Opportunities.

Lesson 15: Concept Selection and Design Process

80 % of the project problems are locked in with concept selection

Lesson 14 indicated how the freedom to make design choices decreases as the design matures. This lesson shows that the constraining effect is powerful; that choices made early in the design process determine the great majority of the system's final attributes—how it operates, the problems it experiences, and what it costs.

- ✦ **The right concept selection is critical. The best detailed design will not correct a flawed concept.**
- ✦ **Put sufficient effort into front-end engineering (Quality Lever).**
 - 8 **Ensure that options are fully explored, converging with successive refinement (greater detail) of concepts and requirements.**
 - **Pick a concept only after appropriate convergence of the various concepts or options; i.e. don't "Eureka" the answer.**
 - 8 **Attain sufficient fidelity before selecting concept**
 - **Don't depend on sizing programs alone.**
 - **In early phases, discipline specialists must assess validity of sizing program results.**
 - 8 **Employ technologies of adequate readiness levels**
 - **Avoid concepts having too many low Technology Readiness Levels.**
- ✦ **Don't roll the dice**

Choice Choice Choice

Selecting the right concept is critical. The best detailed design will not correct a flawed concept. (Conversely, a good concept can be ruined by poor detailed design.) This means that we must put sufficient effort into front-end engineering. Three aspects of what must be done in concept development and selection are highlighted: (1) Fully explore options, (2) Penetrate competing concepts with sufficient fidelity before selecting concept, and (3) Employ technologies of adequate readiness levels.

Fully explore options. Design activity involves conceiving a wide range of competing architectures, concepts, and design alternatives that are candidates to meet system requirements, then sifting and screening out unsuitable or less desirable alternatives to arrive at the best architecture, concept, and design. Additional candidate architectures, concepts, and design alternatives may come to light as the process progresses. These are added to the previous candidates and the screening and successive refinement continues. It is important to ensure that the options are fully explored. We must resist the natural tendency to jump to a solution that appears attractive initially. We should not “Eureka” the concept; instead, use a disciplined approach of applying consistent logic to all alternatives, ensuring that each gets a fair assessment. Pick a concept only after appropriate convergence of the possible concepts.

This philosophy applies in other activities as well. Failure investigations are especially prone to the “Eureka” trap. All possibilities should be explored, and alternatives should be discarded only after clear, consistent logic dictates.

Penetrate competing concepts with sufficient fidelity before selecting concept. Fidelity of definition increases throughout the design process. Before downselecting, it is critical to attain sufficient fidelity in the competing concepts to allow valid comparisons; else the wrong choice may be made. Experience has shown that at the concept selection level, we shouldn’t depend on the fidelity of sizing programs alone, but should involve discipline specialists to assess the validity of the sizing program results. An integrated engineering assessment similar to the Vehicle Integrated Performance Analysis (VIPA) approach can be valuable in this regard.

Employ technologies of adequate readiness levels. Concepts that require too many technologies at a low readiness levels should be avoided. There are various rules of thumb concerning this, the most common being to have no more than two technologies at readiness levels below TRL 6. Any immature technology should have a sound development plan, with off-ramps to alternative approaches should the technology not pan out.

These recommendations are directed toward converging to the right concept in a comprehensive, logical manner. Don’t roll the dice, but make deliberate, correct choices.

While this lesson deals specifically with concept selection, the principles apply also to other phases of the design cycle where alternatives are being assessed, such as trade studies, problem solutions, and block change assessments.

Examples:

- Quality Lever
- Saturn V Concept Selection History
- Space Shuttle Concept Selection History

Examples to be cited are the Quality Lever and a comparison of the concept selections for Saturn and Shuttle. The consequences of the Shuttle’s concept selection on its performance evolution are illustrated.

Quality Lever

The Quality Lever (Figure 15-1) is a classic representation of the leverage and importance that early decisions have on a project. Investment during concept selection and early design is the most influential on product quality. Later in the life cycle the leverage decreases, and after the product is manufactured, the choices are limited to operational procedures required to make it work. Although this principle is generally known, one can make the observation that the reward systems of most organizations give greater recognition to problem solving in the downstream life cycle phases than to the avoidance of problems through good upfront work.

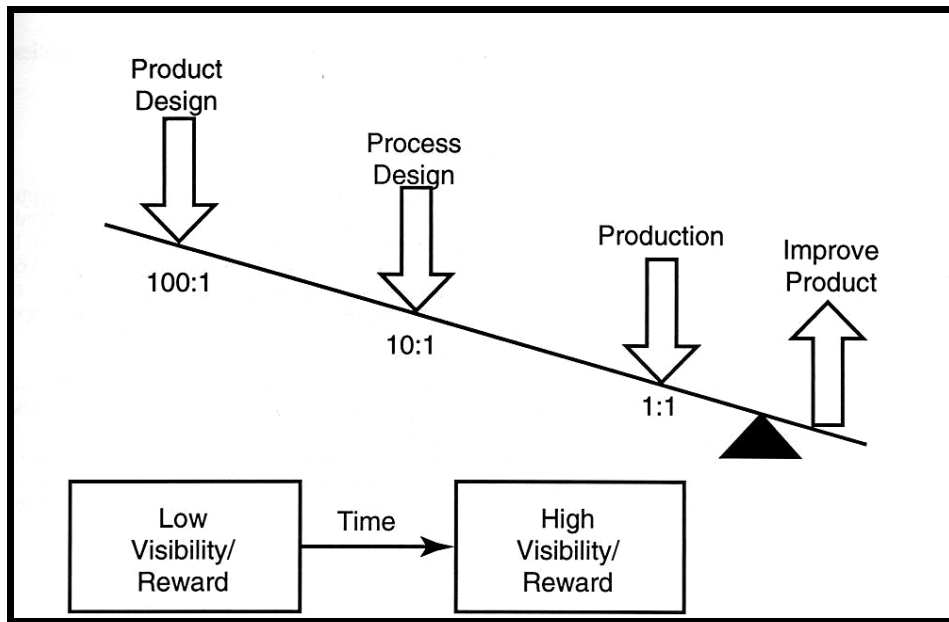

Figure 15-1. Quality Lever

Saturn V Concept Selection History

The Saturn V concept selection and design was an evolutionary process, built on experience from prior systems including Redstone, Jupiter, Saturn I, Saturn IB, and unmanned Saturn V flights (Figure 15-2). This process is described in detail in *Stages to Saturn*. [NASA SP-4206, 1980]

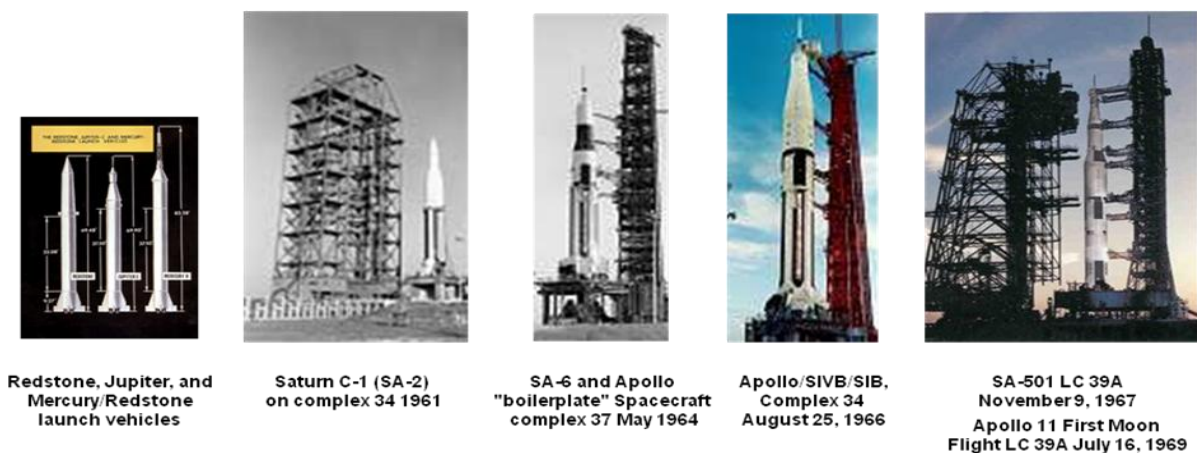

Figure 15-2. Building Blocks for the First U.S. Satellite, First Manned Space Flight, and Saturn/Apollo

Although building a system the size of Saturn V was stepping into uncharted territory, most of its technology and systems represented quantitative steps from prior systems versus qualitative leaps. In addition to this building block approach, the vehicle itself was conceived and designed for simplicity and a minimum number of interfaces, which reduced the number of downstream unknowns and problems. Also, there were three unmanned test flights of Saturn V before a crew was put on the vehicle. This careful process led to successful Apollo launches, culminating in the mission successes represented on Figures 15-3 and 15-4.

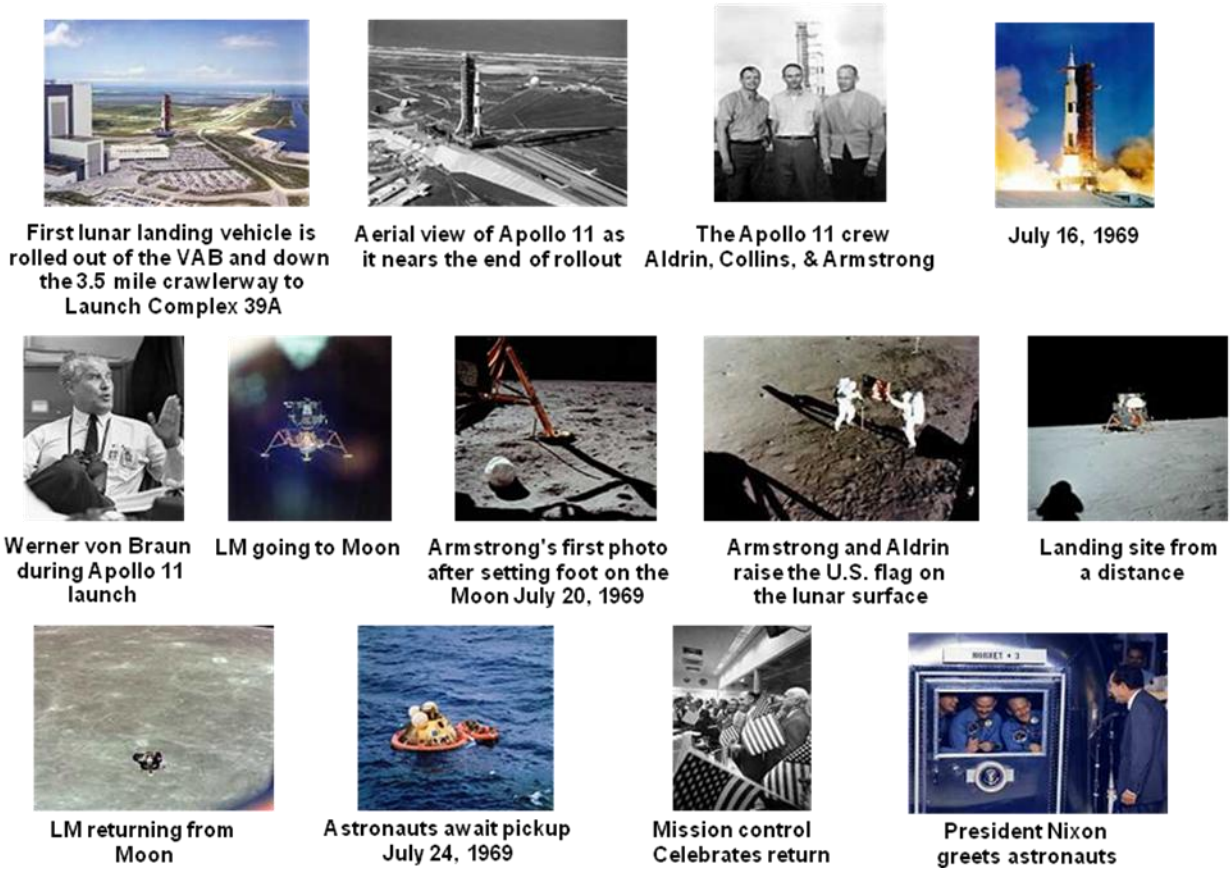

Figure 15-3. Saturn Apollo to the Moon



Figure 15-4. Apollo 11 Lunar Base

Space Shuttle Concept Selection History

The Space Shuttle concept development followed a path quite different from that of Saturn V. Dennis Jenkins' book [Jenkins, 1997] provides an excellent description of the process, both technical and political. The initial idea was to have a fully-reusable system, which would have provided the lowest operational cost for the traffic model envisioned at the time. Many studies involving much effort were focused on two-stage concepts where both the booster and the orbiter were fully reusable. The problem with this approach was the development cost, which was estimated at \$13.5 billion. The budget and political situation at that time did not allow this level of funding, but instead limited funding available for development to \$5.5 billion. This constraint provided little leeway for concept choices. After exploring what could be developed within the funding constraint, NASA converged on the solid-boosted, stage-and-a-half, partially reusable configuration of the current Shuttle (Figure 15-5).

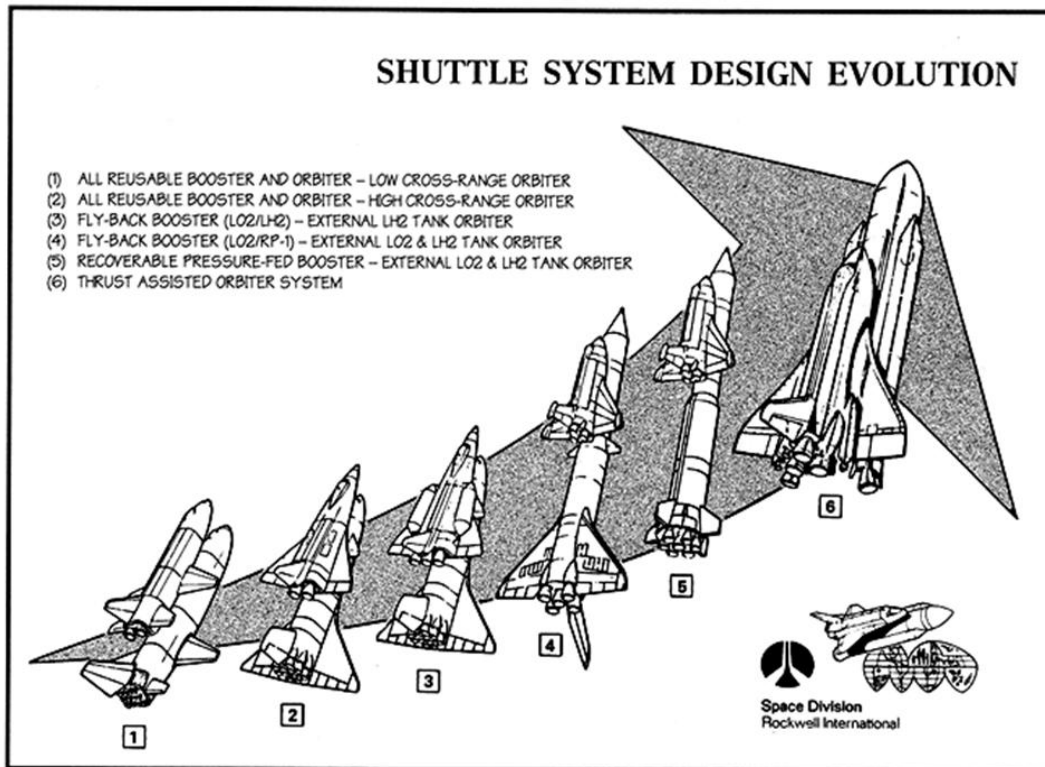

At the end of the Phase B Extension, North American included this chart in their final report showing the conceptual evolution of the space shuttle from Phase A through Phase C. (North American Rockwell)

Ref: *SPACESHUTTLE – The History of the National Space Transportation System*, Dennis R. Jenkins, 1992-2001

Figure 15-5. Space Shuttle Concept Evolution

This configuration had few applicable precedents, and the interfaces were complex instead of simple. Also, the extreme efficiencies demanded by the stage-and-a-half approach resulted in a highly sensitive system. New technologies were required in thermal protection, propulsion, and other areas. Consequently, the development program had many difficulties and operation of the Shuttle remains complex and expensive. The concept that was chosen determined the subsequent complexities and costs.

A look at the evolution of Shuttle payload performance illustrates the sensitivity of the configuration. Lesson 13 addressed the performance loss of the Shuttle due to various design problems and issues. Also discussed were the solution approaches including block upgrades. The following table shows the source of those performance losses and some of the solutions applied. [Author's working papers]

Space Shuttle Performance Evolution

Representative Changes

| <u>EVOLUTION ITEM</u> | <u>IMPACT</u> |
|---|--------------------|
| 1. Orbiter design against real requirements led to not meeting weight target. | -27,000 lbs |
| 2. Environments (loads) increase due to employing quartering high q winds. Several impacts resulted: | -5,000 lbs |
| - Baselining monthly mean wind biasing for design | |
| - Three-axis and elevon load relief | |
| - Increased analysis and testing | |
| - Aerothermal/thermal protection system impacts (SRB and ET) | |
| - Performance loss from path deviations | |
| 3. SRM fixed nozzle was redesigned to a flex gimbaled nozzle for adequate control. | |
| 4. Lift-off loads increases: | |
| - Staggered SSME start and abort shutdown | |
| - Ground winds constraints | |
| - Weight increases / redesigned Shuttle elements (individual payload impacts not documented) | -1,200 lbs |
| - Pre-tensioned SRB/ET struts until LWT tank | |
| 5. Missed aerodynamic predictions / STS-1 lofting | -5,000 lbs |
| - Trajectory constraints on q, SRB separation, alpha trim | |
| - Performance loss | |
| - TPS impacts on ET and SRB | |
| - Reduced launch probability for winter months | 80% |
| - Orbiter wing mods (leading edge) | |
| - Day of launch I-load updates | |
| - Flight-derived dispersions | |
| 6. Isp did not meet design goals | |
| - SSME | -2 ½ sec |
| - SRM | -1 sec |
| 7. STS-1 SRB ignition overpressure | |
| - Modified water injection system (water into thrust buckets) | |
| - Water troughs over drift hole | |
| - Payload loads increases (limited redesign / reverification) | |
| 8. Orbiter tile debond and debris damage | |
| - Operations | |
| 9. Other | |
| - Landing gear and brakes | |
| - Engine upgrades | |
| - SSME fatigue and fracture problems | |
| - ET fracture control | |
| - Isp loss for plugged LOX post | -1 sec |
| - SRB recovery | |

- * Water impact damage
- * Acoustics (reentry)
- * Thermal (reentry)

Approximate Total Payload Loss

- 45,000 lb

The following graph (Figure 15-6) shows the approximate original Shuttle performance and the approximation of the current performance. This performance is plotted for the Air Force mission mentioned earlier. Listed beside the last two bars are performance enhancement solutions that were applied to partially recover the initial losses.

Space Shuttle Performance Evolution

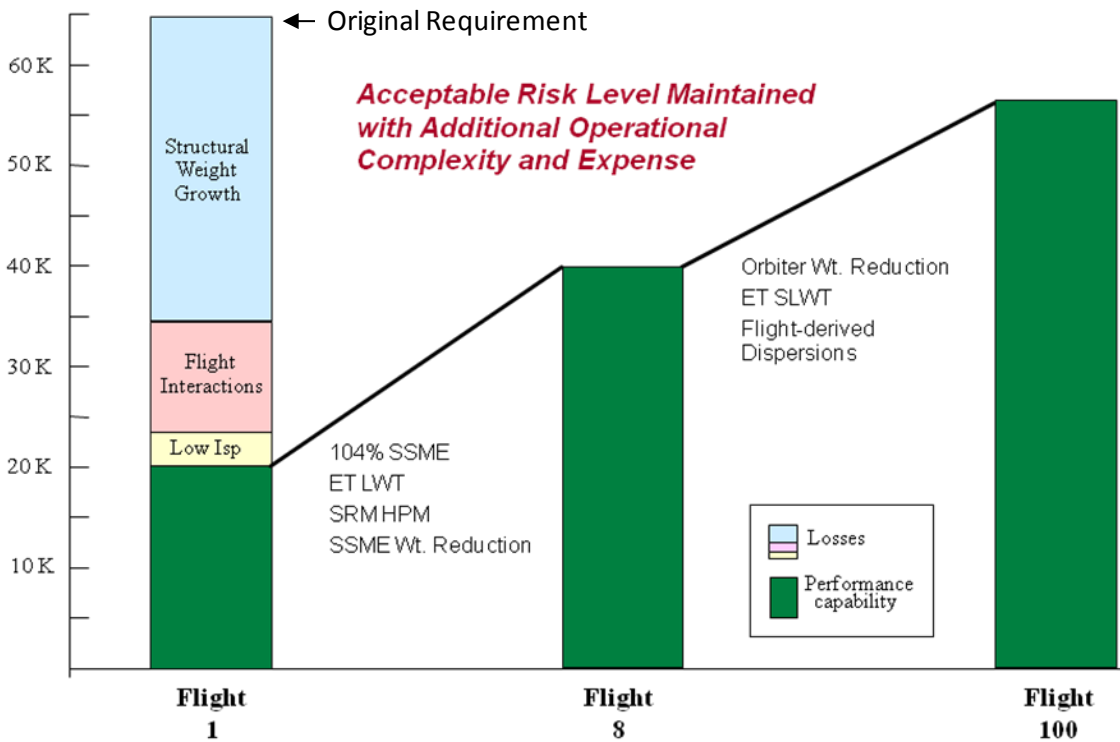

Performance numbers validated in "America's Best Gets Better" <http://spaceflight1.nasa.gov/shuttle/seconddecade>

Figure 15-6. Shuttle Performance Evolution

In summary the Shuttle concept was driven by external requirements and constraints which resulted in complex technical problems, high cost, and operational complexity which entailed a very high sustaining engineering effort. The lesson is clear; we must constantly

drive back on performance requirements and make every effort to obtain as robust a system as possible yet still meet the performance and programmatic requirements.

Was the wrong concept decision made? Addressing this issue in a discussion group, John Yardley acknowledged the Shuttle's operational challenges and costs, but said that the Congressional mandate on constraining development cost had been clear. "Had we not made the choices we did, there would not have been a Shuttle program." Given the political reality, the right choice was made.

The Saturn V and Shuttle examples illustrate the power of concept selection on the life cycle attributes of a system. We need to get it right, up front. Choose the best concept for the total life cycle, after exploring all alternatives. Does this mean that the choice will be free of political or policy considerations? No—it never has been and never will be. And those considerations will seldom be aligned with technical preferences. It is the engineers' responsibility to push back on unrealistic or short-sighted requirements. After the issues have been clearly delineated and vetted, it is the task of engineering to achieve the best system within the remaining constraints.

Achieving the best system entails putting sufficient upfront effort in the project and penetrating competing concepts with sufficient fidelity to reveal main issues and design attributes. This will lead to selecting the right concept, thus providing a major determinant of subsequent project success.

✦ **A key message from Lesson 15 is:**

***Challenge Requirements and Constraints
Penetrate Competing Concepts with Sufficient Fidelity***

Select the Right Concept

Lesson 16: Requirements Drive the Design

✦ ***Requirements drive the design. The higher the performance requirements, the greater the sensitivity of the response. Constraints imposed greatly alter the design.***

- ✦ ***External/political considerations and constraints strongly drive design***
- ✦ ***Technical constraints also drive design, so apply them carefully and judiciously***
- ✦ ***Analyze and challenge requirements, constraints, and criteria at all levels to obtain the greatest possible engineering design flexibility***
- ✦ ***Do not accept unrealistic schedules and budgets***
- ✦ ***Poorly defined and vacillating top-level requirements cost the program dearly in terms of wasted design effort and compromised design***

- **Over-specified criteria suppress the creativity of the design engineer**
- **Criteria must be tailored for the specific project**

“For any given set of TRL’s and basic performance requirements there is a natural shape/size. If you push in one area it will push out in another, creating technical problems and cost and schedule over-runs.” – Garry Lyles

Requirements are the mantle that determines the design, according Pugh in his book *Total Design*. A principle that we have learned the hard way is that “The higher the performance requirements the greater the sensitivity of the design to all parameters which influence the design and the response of the design”. External/political considerations as well as constraints drive the design, many times in undesirable and or unpredictable ways and should be scrubbed to the greatest degree possible. This includes pushing back on unacceptable cost and schedules. Another area that greatly influences requirements is that technical people tend to be very conservative in the development of the design criteria. These criteria should be tailored for each project and be at the minimum required for adequate or acceptable risks.

Examples:

- Sensitivity Versus Performance
- Quotes from Pye and Others
- SSME Experience of Major Failures
 - Fatigue and Fracture Problems
 - LOX Post Failures
 - 4,000 Hz LOX Splitter Vane Problem
 - Additional SSME Problems
- Super Lightweight External Tank

Sensitivity Versus Performance

A principle we learned many years ago in working the numerous SSME problems and failures says: The higher the performance requirements the greater the sensitivity of the system to any parameter uncertainties. Figure 3-3 was a generic plot of the principle. It is repeated here as Figure 16-1. There are two curves shown: one for current technology and one for advanced technology. The shape of the curve does not change with improved technology but shifts down and to the right indicating that one way to reduce sensitivity is to improve the system technologies. The curve also indicates that the higher the performance requirements the greater the effort and depth of analysis and test that will be required to design and operate at that point.

Sensitivity versus Performance

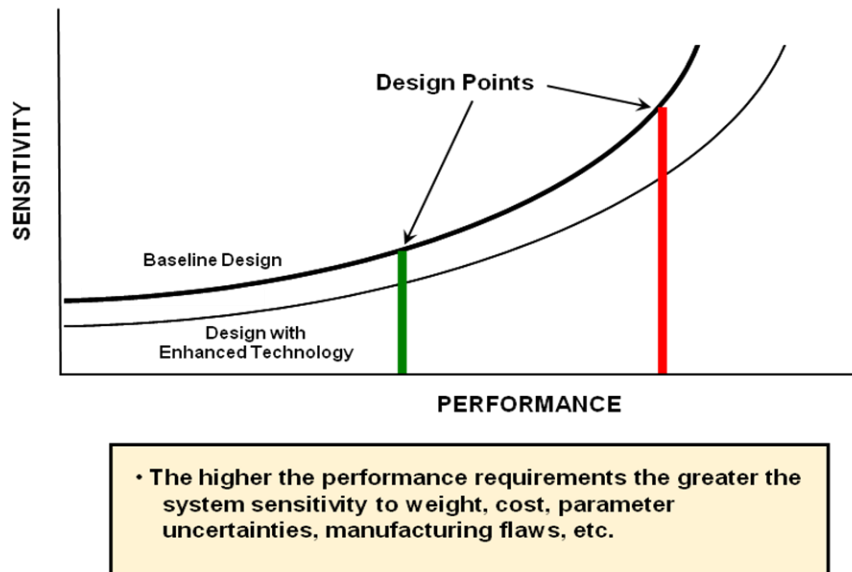

Figure 16-1. Sensitivity versus Performance

Quotes From David Pye & Others

We have collected several quotes that deal with the principle of sensitivity versus performance requirements that are given below without comment.

- “When you put energy into a system you can never choose what kind of changes shall take place and what kind of results remain. All you can do, and that only within limits, is to regulate the amounts of the various changes. This you do by design” - David Pye
- “The requirements for design conflict and cannot be reconciled. All designs for devices are some degree failures...The designer or his client has to choose to what degree and where there shall be failures.” - David Pye
- “All structures will be broken or destroyed in the end. Just as all people will die in the end. It is the purpose of medicine and engineering to postpone these occurrences for a decent interval. The question is: What is to be regarded as a decent interval?” - J.E. Gordon
- “Mother Nature does not read our paper. If we don't follow her way, she lets us fail.” - German Proverb

- “Paper is patient. Sense or nonsense, it accepts what we write.” - German Proverb
- “Cooperate with Mother Nature to the maximum extent possible; minimum energy solutions are almost always the most reliable.” - John Junkins
- “To understand what engineering is and what engineers do is to understand how failures can happen and how they can contribute more than successes to advance technology.” - Henry Petroski
- “All design is essentially creative work and the state of mind of the creator is everything; which is to say that the state of mind of the designer is likewise everything where design is concerned” - Unknown source

SSME Experience OF Major Failures

The performance, weight, and geometric requirements for the SSME Block II are shown below in Figure 16-2. These requirements were derived from Space Shuttle flight requirements that were significantly influenced by the Air Force for payload size and weight and by NASA for a reusable spacecraft. These types of requirements have resulted in an engine with a very high power density of about (879 HP/#). The SSME's have achieved a 100% flight success and a demonstrated reliability of .9995. There have been six configurations leading to the current Block II configuration. The high chamber pressure (~3000 psi), chamber temperature (~6000° F), and high turbopump speeds (fuel pump ~36,600 rpm) were the root causes of many problems because they were out of the design experience band. For example, a number of problems were related to metal fracture and fatigue failures and that resulted in rework cycles.

| | | |
|------------------------------------|--------------------------|-----------------|
| Maximum Thrust: (109% Power Level) | | |
| | At Sea Level: | 418,000 lb |
| | In Vacuum: | 512,300 lb |
| Throttle Range: 67% – 109% | | |
| Pressures: | Hydrogen Pump Discharge: | 6,276 psia |
| | Oxygen Pump Discharge: | 7,268 psia |
| | Chamber Pressure: | 2,994 psia |
| Specific Impulse: (In Vacuum) | 452.3 sec | |
| Power: High Pressure Pumps | | |
| | Hydrogen: | 71,140 hp |
| | Oxygen: | 23,260 hp |
| Area Ratio: | 69:1 | |
| Weight: | 7,774 lb | |
| Mixture Ratio: (O/F) | 6.03:1 | |
| Dimensions: | 168 in. long 96 in. wide | |
| Propellants: | Fuel: | Liquid Hydrogen |
| | Oxidizer: | Liquid Oxygen |

Figure 16-2. Block II Space Shuttle Main Engine Requirements (109% Power Level)

The development cost of the SSME was about \$2.5 Billion (1996 dollars) and required 163 rework cycles to achieve a certified man rated engine, see references [Havskjold, G., Parts 1, 2, and,3, 2009]. As shown in figure 12-1 about 73% of the development cost was related to correct actions (rework cycles).

The following picture is a typical SSME in the test stand during a hot fire test.



Figure 16-3. Space Shuttle Main Engine Firing

The SSME is a staged combustion engine that has two low pressure pumps that attach to the Orbiter, two high pressure pumps attached to the engine. The LOX pump pairs and the fuel pump pairs are connected with ducts which have sections with bellows so that the engine can be gimbaled. The other elements are shown on Figure 16- 4, such as, the nozzle, combustion chamber, preburners, controllers etc. There were many problems and failures of these elements during development testing. [Cikanek, 1987] The engine that is flying today has had six block upgrades to solve these various issues, some that have already been discussed in previous sections.

SSME With Identified Components

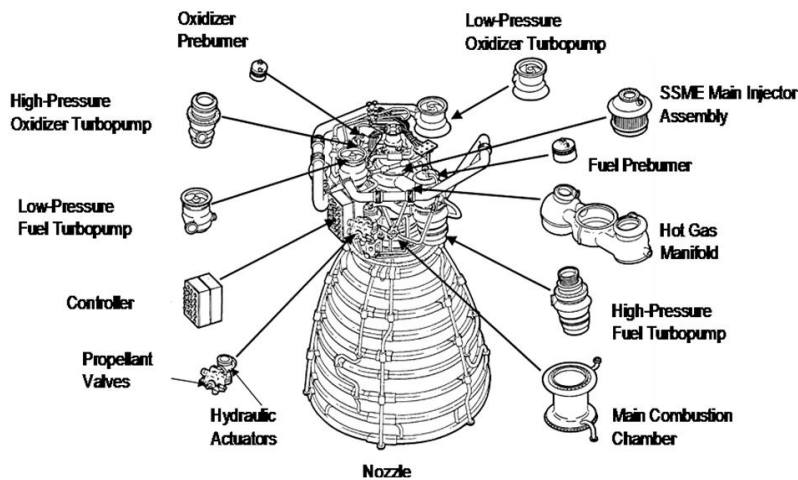

Figure 16-4. SSME Components

The total SSME component corrective actions during full scale development is summarized in Figure 16-5, see references [Havskjold, G., Parts 1, 2, and, 3, 2009]. As can be seen there were 163 rework cycles, but the cost of about half of these rework cycles was very little.

| Engine | Number of Failure Modes Internal to Engine | Turbomachinery | Combustion Devices | Engine System | Valves | Interconnects | Other |
|--------|--|----------------------|---|---------------|--------|---------------|---|
| SSME | 163 | 51 HPOTP 42 HPFTP | 8 Nozzle 6 Main inj 3 Fuel prebr 0 MCC | 17 | | | 37 heat exch, low press pump, sensors, controller |

Figure 16-5. Total Failures During SSME Development

However, shown in Figure 16-6 are 38 significant failures that occurred during development testing. There were eighteen \$50 million engines totally consumed. Figure 16-6 provides an indication of the variety of different hardware elements that failed. The cost of each of these failures was \$30 Million or greater. Since the SSME was an advanced technology engine there was a lack of understanding of environments, hardware characteristics, advanced computational tools, and overall design experience.

| Failure Number | Date | Test Number | Failure | Engine S/N | Rocketdyne Report |
|----------------|-------------------|-------------|--------------------------------|------------|-------------------|
| 1 | March 24, 1977 | 901110 | HPOP Pri Lox Seal | 0003 | RSS-8595-11 |
| 2 | August 27, 1977 | 901133 | Fuel PB Burnthrough | 0004 | none |
| 3 | September 8, 1977 | 901136 | HPOP Bearing | 0004 | RSS-8595-13 |
| 4 | November 11, 1977 | 902095 | HPFP Turbine Blade | 0002 | none |
| 5 | December 1, 1977 | 901147 | HPFP Turbine Blade | 0103 | none |
| 6 | March 31, 1978 | 901173 | Main Injector Lox Post Failure | 0002 | none |
| 7 | June 5, 1978 | 901183 | Main Injector Lox Post Failure | 0005 | none |
| 8 | June 10, 1978 | 902112 | Eng Fuel Supp Blockage | 0101 | RSS-8595-14 |
| 9 | July 18, 1978 | 902120 | HPOP Cap. Probe | 0101 | RSS-8595-15 |
| 10 | October 3, 1978 | 902132 | MOV Improperly Installed | 0006 | none |
| 11 | December 6, 1978 | 901222 | HX Failure | 0007 | RSS-8595-17 |
| 12 | December 27, 1978 | 901225 | MOV Freting | 2001 | RSS-8595-18 |
| 13 | May 14, 1979 | 750041 | Nozzle Steerhorn Failure | 0201 | RSS-8595-19 |
| 14 | July 2, 1979 | SF06-1 | MFV Housing | 2002 | RSS-8595-20 |
| 15 | November 4, 1979 | SF06-3 | Nozzle Steerhorn Failure | 2002 | RSS-8595-21 |
| 16 | July 12, 1980 | SF10-1 | FPB Burnthrough | 0006 | none |
| 17 | July 23, 1980 | 902198 | Main Injector Lox Post Failure | 2004 | none |
| 18 | July 30, 1980 | 902284 | MCC Lee Jet | 0010 | RSS-8595-22 |
| 19 | January 28, 1981 | 901307 | FPB Injector Lox Post | 0009 | RSS-8595-24 |
| 20 | July 15, 1981 | 901331 | Main Injector Lox Post Failure | 2108 | none |

| | | | | | |
|----|--------------------|--------|--|-------|-------------|
| 21 | September 2, 1981 | 750148 | Main Injector Lox Post Failure | 0110 | None |
| 22 | September 21, 1981 | 902249 | HPFTP Blade Failure- FPB Deactivated Lox Posts | 0204 | RSS-8595-23 |
| 23 | October 15, 1981 | 901340 | Fuel Pump Turnaround Duct | 0107 | none |
| 24 | February 12, 1982 | 750160 | FPB Fuel Supply Blockage - Ice | 0110F | RSS-8595-27 |
| 25 | April 7, 1982 | 901364 | Kaiser Hat Nut | 2013 | RSS-8595-28 |
| 26 | May 15, 1982 | 750168 | OPOV Leak | 0107 | RSS-8595-29 |
| 27 | August 27, 1982 | 750175 | HPOP Disch. Duct (U/S FM) | 2208 | RSS-8595-30 |
| 28 | February 14, 1984 | 901436 | Coolant Liner Failure | 0108 | RSS-8595-37 |
| 29 | February 4, 1985 | 901468 | FPB Instr Boss Crack | 0207 | none |
| 30 | March 27, 1985 | 750259 | MCC Outlet Neck Blow | 2308 | RSS-8595-39 |
| 31 | July 1, 1987 | 902428 | OPB Injector Braze | 2106 | none |
| 32 | June 6, 1989 | 902471 | LPF Flex Joint | 2206 | RSS-8595-43 |
| 33 | June 23, 1989 | 904044 | HPOP Pump End Bearing | 0212 | RSS-8595-44 |
| 34 | November 6, 1991 | 901674 | CCV Failure | 2032 | |
| 35 | June 18, 1992 | 902562 | OPOV Leak | 2107 | |
| 36 | January 25, 1996 | 901853 | HPFTP Blade Failure | 0523 | |
| 37 | August 27, 1997 | 901933 | Nozzle Tube Rupture | 0524 | |
| 38 | June 6, 2000 | 902772 | FPB Fuel Manifold Tape Contamination | 0523 | |

Figure 16-6. Significant SSME Failures

In a comparison of the SSME to the F-1 and J-2 engines, it can be seen that all three are advanced technology engines and their technical uncertainty factors are high and similar. As a consequence their development costs and their rework cycles are similar. To reduce development costs in the future, it is clear that the technical uncertainty factor has to be reduced. Finally, it is noted that the SSME is the only reusable rocket engine certified for human flight.

SSME Fatigue and Fracture Failures

In the baseline design of the SSME there were *no fracture mechanics design requirements and the material properties were based upon predicted minimum values*. A fracture mechanics plan was established in 1973 after the basic design was completed and drawings released. In May 1980 a structural audit was completed [Mulloy, et.al., 1980] before the first flight. The main findings relating to structural practices were: the structural design data base of the SSME is mature and analytical practices are state-of-the-art; material properties are *predicted minimums*. The main findings relating to component assessments were: eleven components did not meet verification criteria and of these three had failure probabilities of an order of magnitude less than others. Nozzle failures are a dominant factor in reducing structural criteria and that is a result of process control and contamination not structural design deficiencies. The major findings related to structural reliability were: a comparison of the SSME to The J-2 indicated the emanation rate of UCR's was similar and failure rate trends of both engines were similar with reliability expected to improve substantially with increased firing time. As of March 30, 1980 the probability of a structural failure of an STS-1 engine during a mission resulting in loss of life or mission was 0.05.

In the activity associated with the 1973 fracture mechanics plan, 150 welds were identified as “fracture critical”. They were implemented based on NDE improvements as opposed to redesign [Rocketdyne Presentation, 1989]. Prior to 51L, welds were selectively assessed. After 51L, the Critical Items List (CIL) assessment for welds was expanded to identify all critical welds. The idea was to prepare rationale for retention for all welds prior to flight, identify and implement corrective action as required, and establish a weld data base for rapid screening of future weld issues. At that time, the material data base contained 1150 pages of design properties. Forty-three percent of these were *predicted minimums* with some unverifiable sources, extrapolations, and empirical relationships. The material data base was upgraded to include 26 SSME materials tested in 8500 tests with 1400 in high pressure hydrogen. In addition, the fracture mechanics data base was expanded including weld defect testing.

During the weld assessment [Rocketdyne Presentation, 1989], the FMEA/CIL weld statistics included 3,165 welds. Initially, there were about 2000 welds operating at yield conditions and this condition resulted in failures during hot fire testing. The system was sensitive to manufacturing tolerances resulting in eccentricities and misalignments in weld offsets. As can be seen in the illustration in Figure 16-7 below, there were weld mismatches in duct joints. Wax molds were required for each weld to determine the exact geometry for structural lifetime assessments.

A total weld count was undertaken on the SSME Block I configuration and there were 23,055 welds; 10,698 welds were made by Pratt & Whitney Rocketdyne and 12,357 made by suppliers where 12,000 of these were resistant spot welds on metallic TPS. [Zimmerman, 2010] A weld comparison of the SSME Phase II configuration (1988) to the presently flying Block II configuration shows that over 1000 welds have been eliminated from the engine in the combustion devices and the turbopump components. [Benefield, 2010]

Although there were no fracture mechanics requirements and material properties were predicted minimum values in the baseline design, material properties have since been established through laboratory and hot fire testing. The weld joints margin and reliability have been increased by improvements in weld processing, verification and inspection, analytical assessment, design, hot fire measurement, and materials testing.

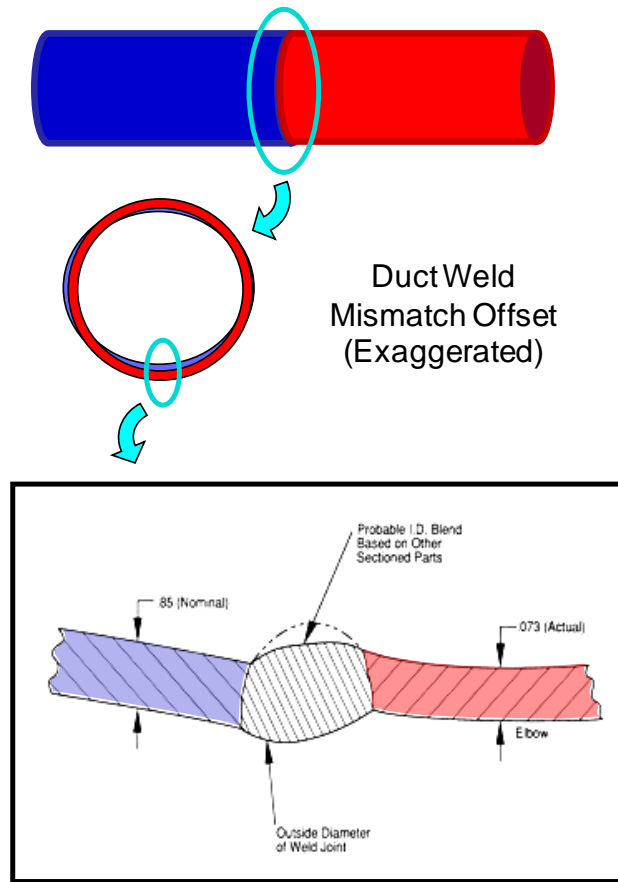

Figure 16-7. Weld Offset Mismatch

SSME Fatigue and Fracture LOX Post Failures

During the development of the SSME there were five engine failures caused by high cycle fatigue (HCF) of LOX posts in the main injector assembly. During inspection of all other injectors, there were an additional two found with cracked LOX posts. Shown in Figure 16-8 below are the power head, main injector, and turbo-pump assemblies.

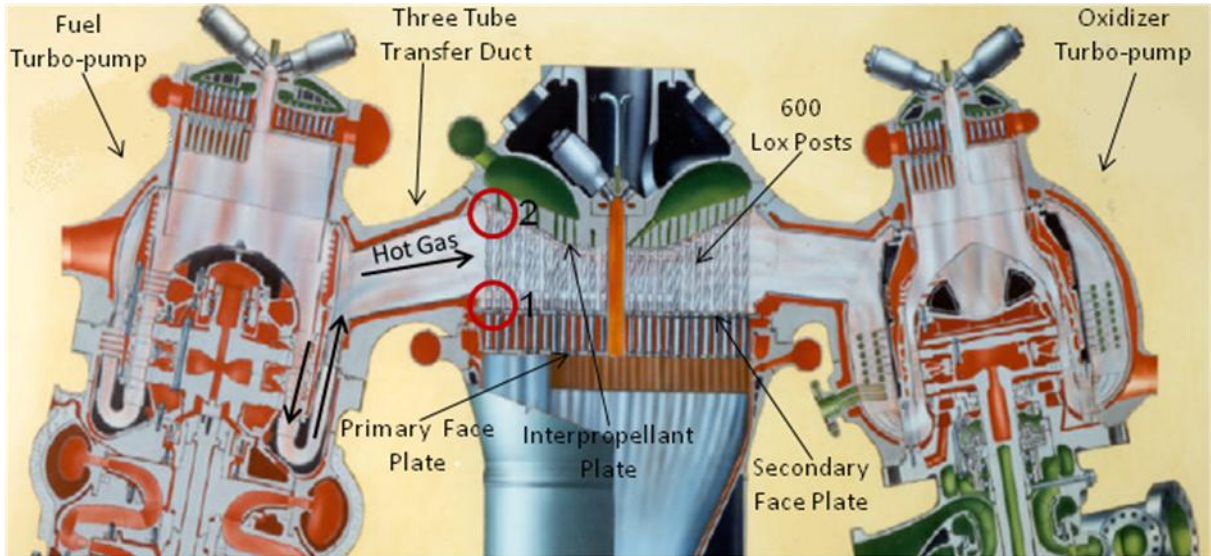

Figure 16-8. Power Head, Main Injector, and Turbo-pump Assemblies

There are 600 LOX posts in the injector that transport LOX to the primary face plate of the injector. The HCF failures were caused by static stress (thermal and pressure) and dynamic stress i.e., vortex shedding about the posts. About 70% of the hot gas comes from the fuel side while 30% comes from the oxidizer side [Pelaccio, et. al, 1984]. The hot gas from the fuel turbine swirls as it goes through an 180° turn and then abruptly enters the three tube transfer duct, see Figure 16-8. This highly energetic, non-uniform, separated, and turbulent flow then impinges on the LOX posts. The failures resulted from the 70% hot gas flow from the fuel side and were in the regions indicated by the circles 1 and 2.

Shown in Figure 16-9 are failed LOX posts from the first incident (Engine E0002). On the left side of the figure, the deformation due to loading can be seen and on the right side, the post burn out can be seen as viewed looking at the primary face plate.

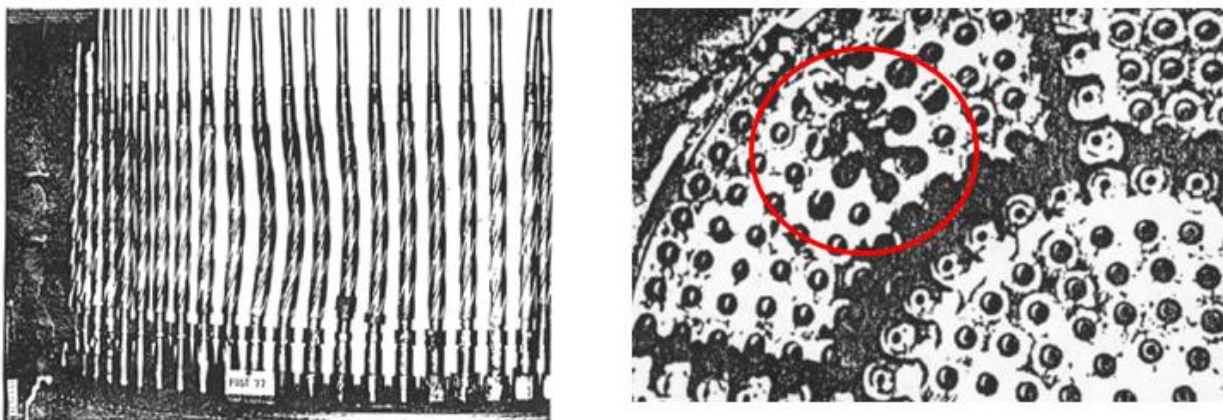

Figure 16-9. Lox Posts Failures (Engine E0002)

Initially cracking occurred in the threads of the LOX posts tips as shown in Figure 16-10. Once there was a through crack, high pressure LOX flowed into the fuel region of the post causing a fire in the LOX post. When the post burned through, it allowed LOX flow into the fuel rich region between the secondary and primary face plates of the injector causing burning of other LOX posts between the face plates. The region of the failure is shown in Figure 16-8 by circle 1.

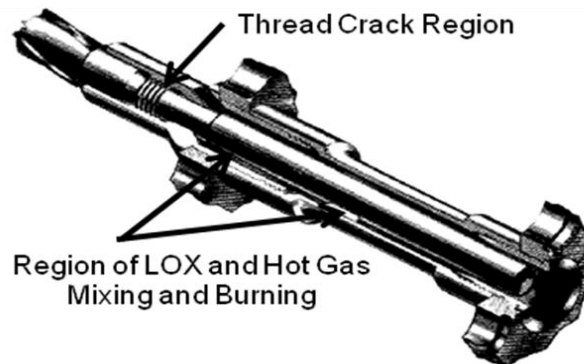

Figure 16-10. LOX Post Failure Mechanism

LOX post failures as described above were on: Engine E0002, 3/31/78; Engine E0005, 6/5/78; and Engine E2004, 7/23/80. [Hopson, August 1980] After Engine E0005 failure, flow shields were added, but with a different injector. After testing cracked shields were found but no burn-throughs. The next engine with flow shields was Engine E2004. The purpose of the flow shields was to divert the flow and carry some of the load. However, posts still cracked and burned but around the side of the injector where there were no shields, see Figure 16-11.

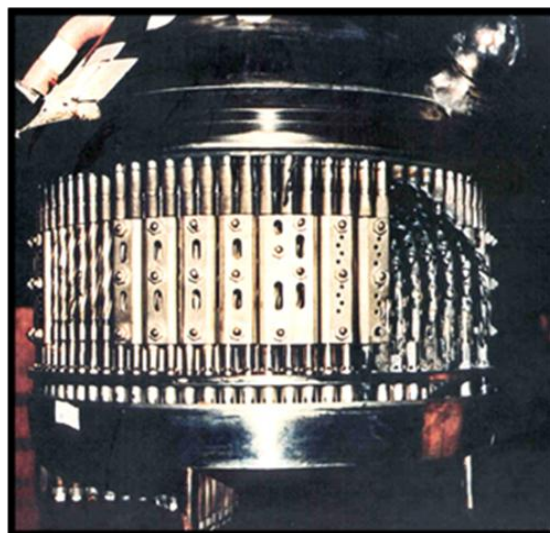

Figure 16-11. Engine E2004 Injector Failure

Locations of LOX failures on engines E0002, E0005, and E2004 are shown in Figure 16-12.

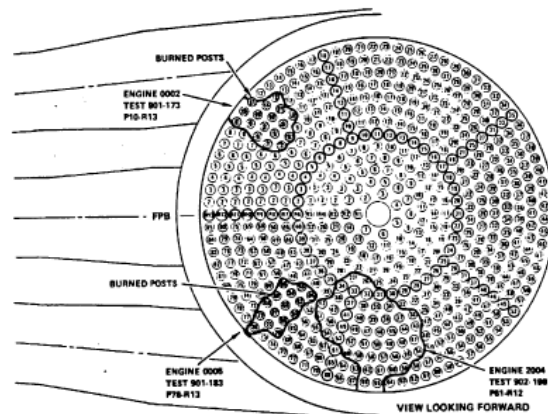

Figure 16-12. LOX Post Failure Pattern

In order to continue engine development testing, additional modifications were made to the injector. The LOX posts were made of 316L Cres steel and for engine E2108 the material of the tips of the posts was changed to Haynes 188. In addition, flow shields were put on all injector posts around the outside circumference of the injector. In the test of engine E2108 (7/15/81) [Hopson, July, 1981] and engine E0110 (9/2/81) [Hopson, September, 1981], LOX posts again failed due to HCF. However, these cracks occurred at the top of the posts in the inertial weld region in the vicinity of the interpropellant plate, see Figure 16-8, circle 2. LOX flowed through the cracks into the region between the interpropellant plate and the secondary face plate causing a fire. It is thought that the E2108 failure resulted from a more severe (unanticipated) flow environment in going from RPL to FPL and from modifications to the fuel turbopump to achieve FPL. The LOX posts were then redesigned for the more severe environment. In the case of the subsequent engine E0110 failure, inspection of some of the undamaged posts revealed manufacturing defects in the inertia weld even though there had been pretest inspections. Inspection procedures were improved to mitigate future failures. Eventually, all LOX post material was changed to Haynes 188. The changes made to the injector assembly resulted in a reduction of the engine I_{SP} of about 1.5 seconds (600 pound payload reduction).

In order to increase margin and performance while improving safety and reliability, efforts were taken to redesign the hot gas flow path on the fuel side of the hot gas manifold. The three tube transfer duct was changed to a two tube transfer duct with an increase in area of 30%; increased the turnaround duct exit area by 68.5%; and increased the fishbowl cross-sectional area 75.3%. These increased cross-sectional areas have the effect of reducing the dynamic pressure ($\frac{1}{2}\rho V^2$) and thus the static and dynamic flow loads. Then inlet and outlet regions of the tubes were rounded. The transfer ducts were flared into the fuel preburner housing and main injector housing. In addition, contoured turning vanes were used to make the flow into the transfer ducts from the fuel turbine more uniform and decrease the fuel turbine exit pressure gradient. The effect of these changes was to make the flow more

uniform [Pelaccio, et. al., 1984]. In the two tube transfer duct design 72 welds were eliminated and there were 52 fewer detailed parts. This lead to a 40% cost reduction in comparison to the three tube system [Jue, 1997].

Shown in Figure 16-13, are blended pressure contours of the three tube and two tube transfer duct configurations obtained from CFD computations [Ames Research Center, 2000]. It can be seen that the flow of the two duct system is more uniform than the three duct system, thus reducing loads and flow losses.

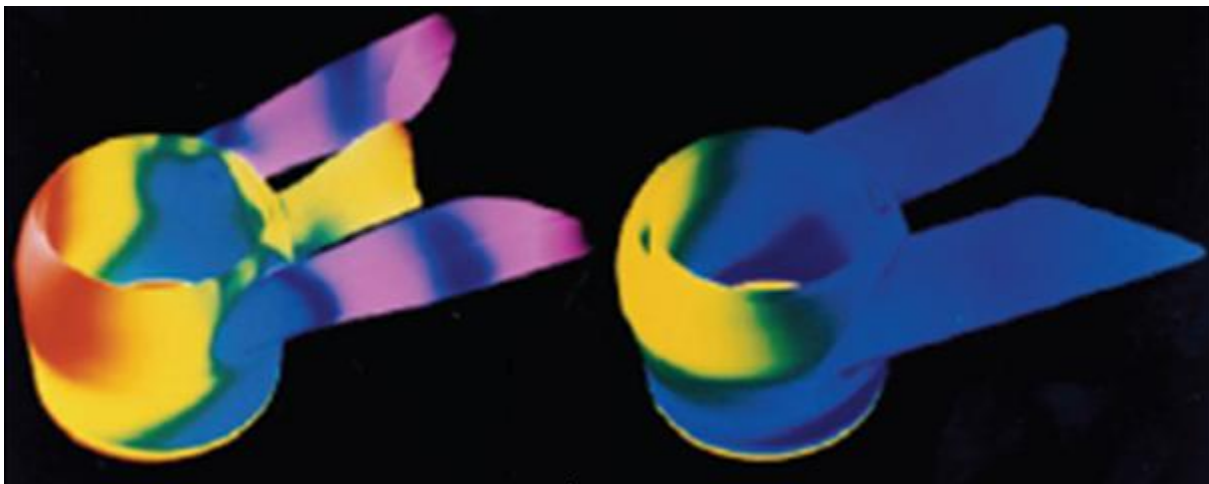

Figure 16-13. Fuel Side of the Hot Gas Manifold

Shown in Figure 16-14 is a comparison of the circumferential total pressure distribution of the three tube and two tube transfer ducts. It can be seen that the two tube system is significantly more uniform than the three tube system.

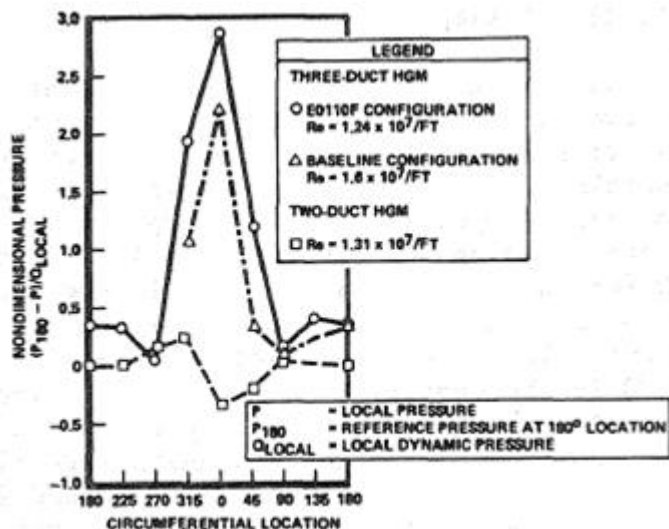

Figure 16-14. Total Pressure Variation Downstream of the Turnaround Duct 180°-Turn

In the initial development of the SSME the severity of the flow environments in the hot gas manifold were not anticipated. There were no adequate requirements regarding flow static and dynamic environments or effects of flow uniformity in the design of the gas path or injector. The consequences were failures of five engine injectors. In addition, there were two distinct types of failures. Extensive measurements were made in hot fire tests as well as scale model tests to finally understand the flow environment and design out failure mechanisms. Subsequently, this configuration became the baseline and was certified for flight.

This configuration was designated Block I and was first flown on the STS-70 flight in July 1995. The SSME has been further upgraded and the changes describe herein are in those upgraded engines.

4000 Hz LOX Splitter Vane Problem

During development testing of the SSME, the power levels of the engines were increased incrementally over time to assess the overall performance and condition of the hardware as the power level increased. When the power level was increased to 109% accelerometers on the gimbal bearing of engine E2025 recorded high vibration levels that were close to 100 g's RMS at a frequency of 4000Hz, [Jones, et, al., 1994]. The source of the vibration was traced to LOX inlet/tee location on the SSME Powerhead, see Figure 16-15.

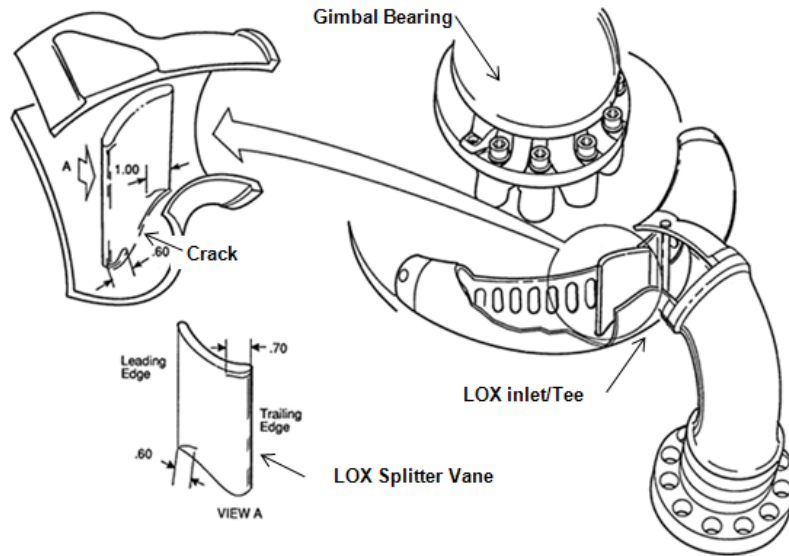

Figure 16-15. Gimbal Bearing, LOX Inlet/Tee, and Splitter Vane

The E2025 engine hardware was examined and there was no evidence of damage. A review of data from 22 engines and 14 power heads revealed that only engines tested at power levels above 100% (and not all of them) had the 4000Hz vibration. Inspection of the hardware revealed that it was within manufacturing tolerances. However, there was cracking on one vane near the outer shell of the tee on engine E2116 and on engine E0005B both vanes were cracked.

Simultaneously, structural and CFD modeling, water flow and LN₂ tests, and careful examination of the hot fire vibration data revealed vortex shedding from the LOX inlet Tee's splitter vanes' blunt trailing edge at a frequency of 4000Hz. [O'Connor, et. al., 1988] It was determined that this frequency tuned with the vane's first torsional mode frequency resulting in high vibration levels. While tuning is the most significant factor, the high amplitudes were the result of the flow's high dynamic pressure ($\frac{1}{2}\rho V^2$) of about 275 psi.

To eliminate the high vibration levels two distinct changes were made to the hardware. One change was to asymmetrically bevel the trailing edge of the vane to suppress the vortex shedding. The second change was to scallop the leading edge of the vane to shift the torsional mode frequency higher and out of the operational range, see Figure 16-16. It also reduced the turbulence induced background noise.

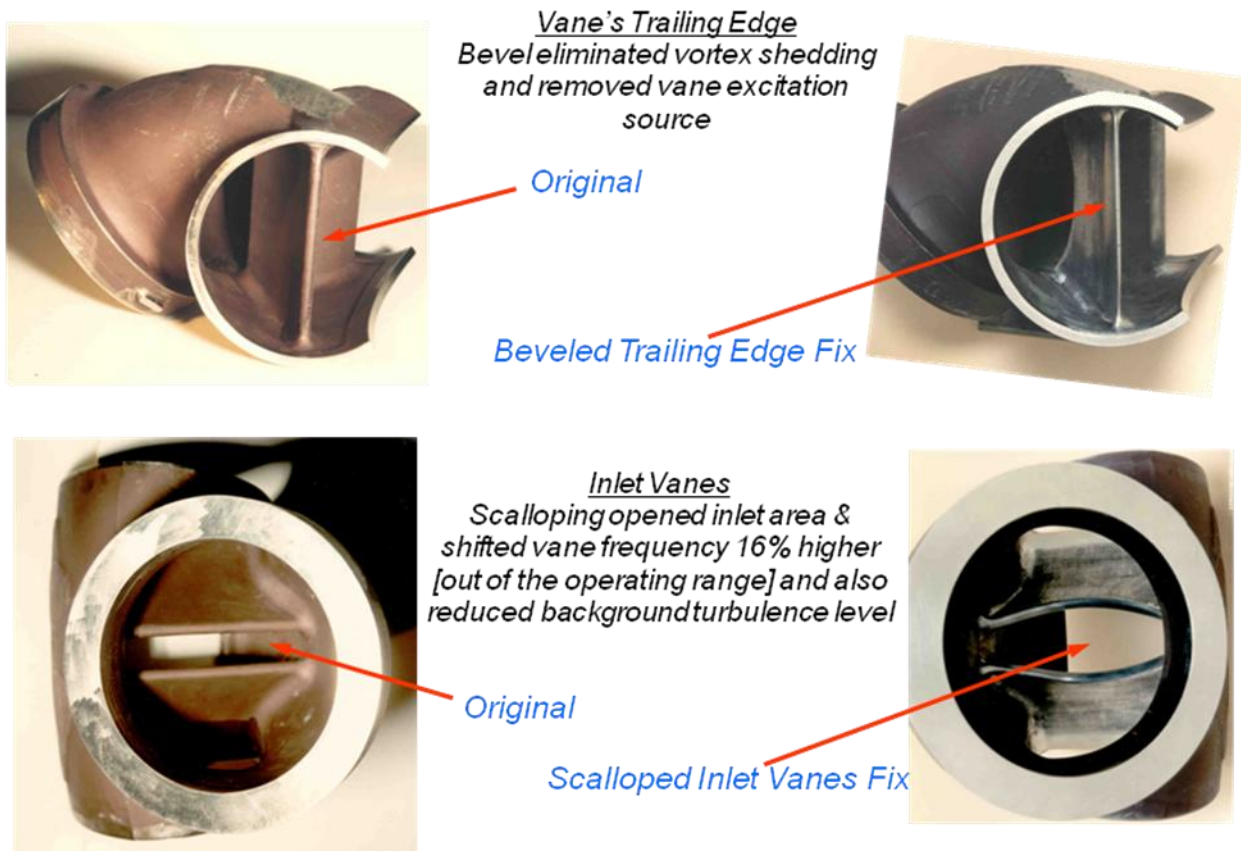

Figure 16-16. 4000Hz Splitter Vane Fixes

These changes were developed after extensive analysis and testing and were verified by water flow testing. The bevel at the vane's trailing edge completely eliminated the vortex shedding source. The inlet vane change was made in order to provide an added margin of safety. These fixes were eventually certified on hot fire testing and all engines were appropriately modified. It was first flown on STS-26 in September 1988. Both 4000 Hz changes described above were first implemented on E0212. Engine E0212 (which was originally named E2025) provides a direct comparison, with and without the 4000 Hz modification, and is shown in Figure 16-17. This is the gimbal bearing accelerometer measurement and it dramatically demonstrates the effectiveness of the fix.

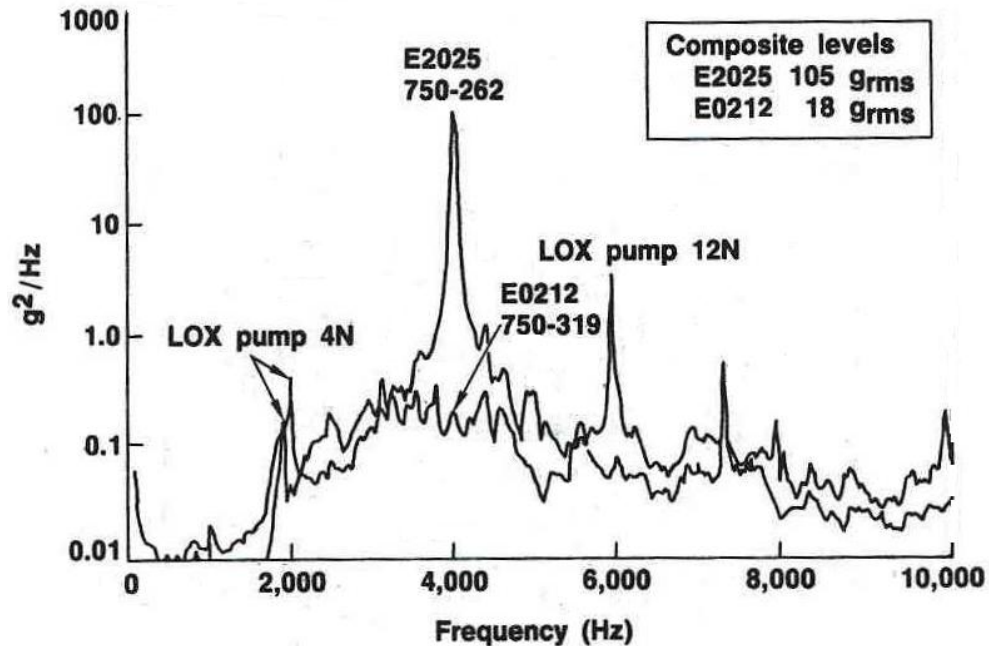

Figure 16-17. 4000 Hz Eliminated

The 4000Hz LOX splitter vane is a situation where the hardware was manufactured and inspected and met design specifications. However, this falls into a category of an unknown/unknown, since requirements were not anticipated to adequately design the splitter vane system. As the power level of the engine increased the vortex shedding frequency tuned with the vane first torsional mode frequency along with the condition of a high dynamic pressure resulting in vane cracking. This failure was caught in the act before it consumed any engines.

Additional SSME Design and Operational Problems

One SSME Subsystem is shown on Figure 16-18 as an example of the historical data available.

HPOTP/ATD Development Problems

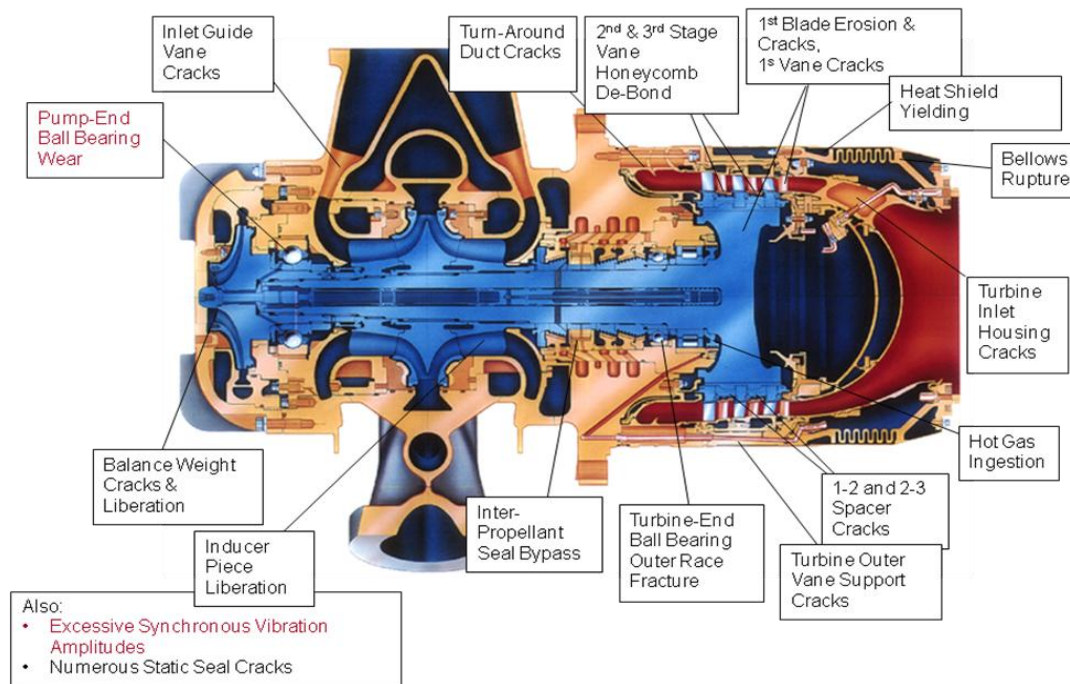

Figure 16-18. Development Problems of the SSME Alternate High Pressure LOX Turbopump

Super Lightweight External Tank

The requirements for the Space Shuttle to launch and service the International Space Station (ISS) resulted in the need to increase the Shuttle ascent performance. The Shuttle had been flying several years and was basically a fixed configuration. Therefore the major approach open for performance increase was a weight reduction program of the major components of the Shuttle. The External Tank was a prime target for mass reduction, since a one pound tank weight reduction produced a one pound performance increase. Figure 16-19 illustrates that by changing the material of the tank to aluminum lithium and changing its construction to orthogrid while maintaining its external configuration and tank volume saved 7,500 pounds of weight and resulted in a payload increase of 7,500 pounds. To accomplish this dramatic change, a reverification of the structure and the fracture mechanics program was required. [Presentation by Neil Otte, Ryan's working papers] Also the manufacturing process and the weld repair process had to be changed and verified. Protoflight testing of the hydrogen tank in conjunction with proof test was an additional complication that required each tank built to have the protoflight test to insure the tank had adequate buckling margins. The lesson is clear-- changing requirements during operations of a program adds additional risks and cost.

Achieving High Inclination Space Station Orbit

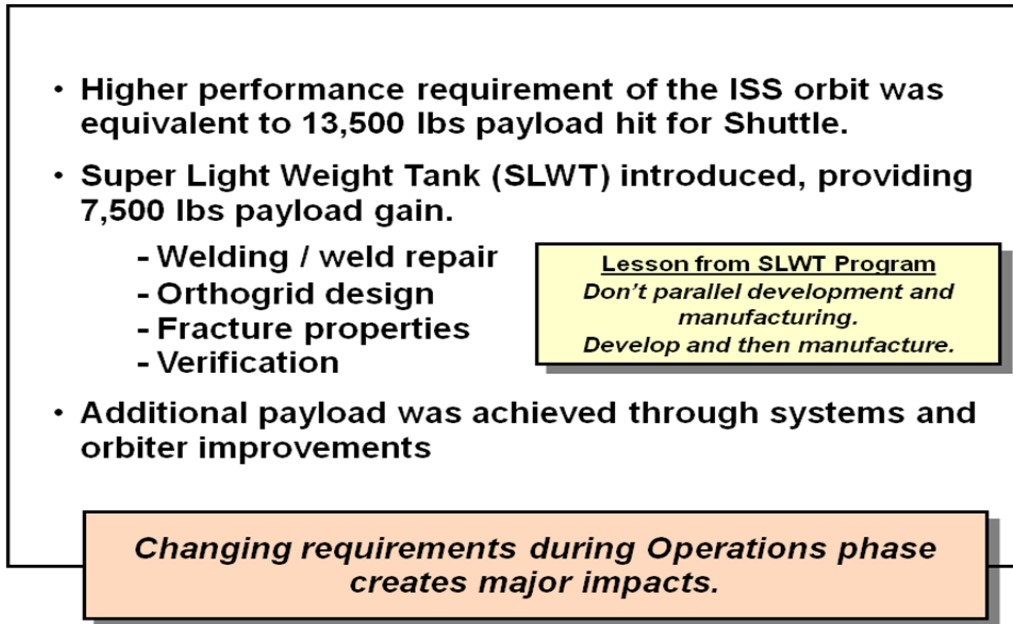

Figure 16-19. Impact of ISS Orbit Requirements on External Tank

✦ **A key message from Lesson 16 is:**

High Performance Requirements Cause

***High Power Density
High Sensitivity
Unwanted Interactions***

which result in

***Lower Margins
Higher Risk
Higher Cost
Operational Complexity***

Push Back on Requirements and Strive to Achieve Robustness.

Lesson 17: Designing for The –ilities and Cost

- ✦ **The –ilities and Cost Must Be On the Design Table If We Are To Be Successful**
- ✦ **Challenge Requirements and Constraints**
- ✦ **Penetrate Competing Concepts with Sufficient Fidelity**
- ✦ **Select the Right Concept**

The success of a launch system is measured not only by its physical performance parameters such as how much payload it can lift to orbit, but by its reliability, its operability, how much it costs, and numerous other attributes. A successful system must be designed from the start for these “-ilities” and costs as well as for physical performance. In order to do this, the designer must be provided functional relationships that connect the design variables available to him/her with how they affect vehicle’s future operation—its -ilities and costs. We call this “putting the -ilities and cost on the design table” (or more currently, “on the CAD system”). The -ilities and costs can then be part of the system optimization along with physical performance.

Examples

- Space Shuttle Day of Launch I-Load Update (DOLILU)
- Designing Considering the Total Life Cycle
 - How We Previously Designed for the -ilities and Cost
 - How We Should Design for the -ilities and Cost

We will first look at the Shuttle Day of Launch I-Load Update process as an example of operational complexity not foreseen in the initial design, then compare how we have designed for the -ilities and cost in the past with how we should design for them in the future.

Shuttle Day of Launch I-Load Update

Wind biasing as a means of reducing structural load was discussed in Lesson 6 on the Balancing Act. There we noted that the Shuttle was intended to be designed with enough structural strength to allow launch using a trajectory biased for the monthly mean wind. Because of the aerodynamic anomaly described in Lesson 4, the Shuttle in fact wasn’t strong enough to be launched with monthly mean biasing, but required biasing for the winds measured on the day of launch. A Day of Launch I-Load Update (DOLILU) process was required, which entailed significant operational complexity and expense. Wind biasing involves calculating the guidance parameters based on the bias wind, and loading them into the flight computer. With monthly mean biasing, this process can be accomplished and verified well ahead of launch day, but with day-of-launch wind biasing, all this must be done in a short time span based on winds measured a few hours prior to launch. [Norbraten, 1992]

Figure 17-1 shows some example elements of the DOLILU process for Shuttle. At several times prior to launch, balloons are used to measure winds and atmospheric parameters. The wind measured at L minus 3:45 hours is smoothed and used to bias the first-stage guidance commands so that if the vehicle in flight should experience that same wind, there would be no wind-induced loads. In actuality, the wind will change between the time the balloon measures it and the vehicle flies through it, but biasing to the balloon-measured wind will minimize the wind-induced load. The biased first-stage guidance commands that have been generated must be verified, approved, and then loaded into the flight computer prior to launch. The trajectory command set is called an I-load.

Example Elements of Day of Launch I-Load Update (DOLILU) Process

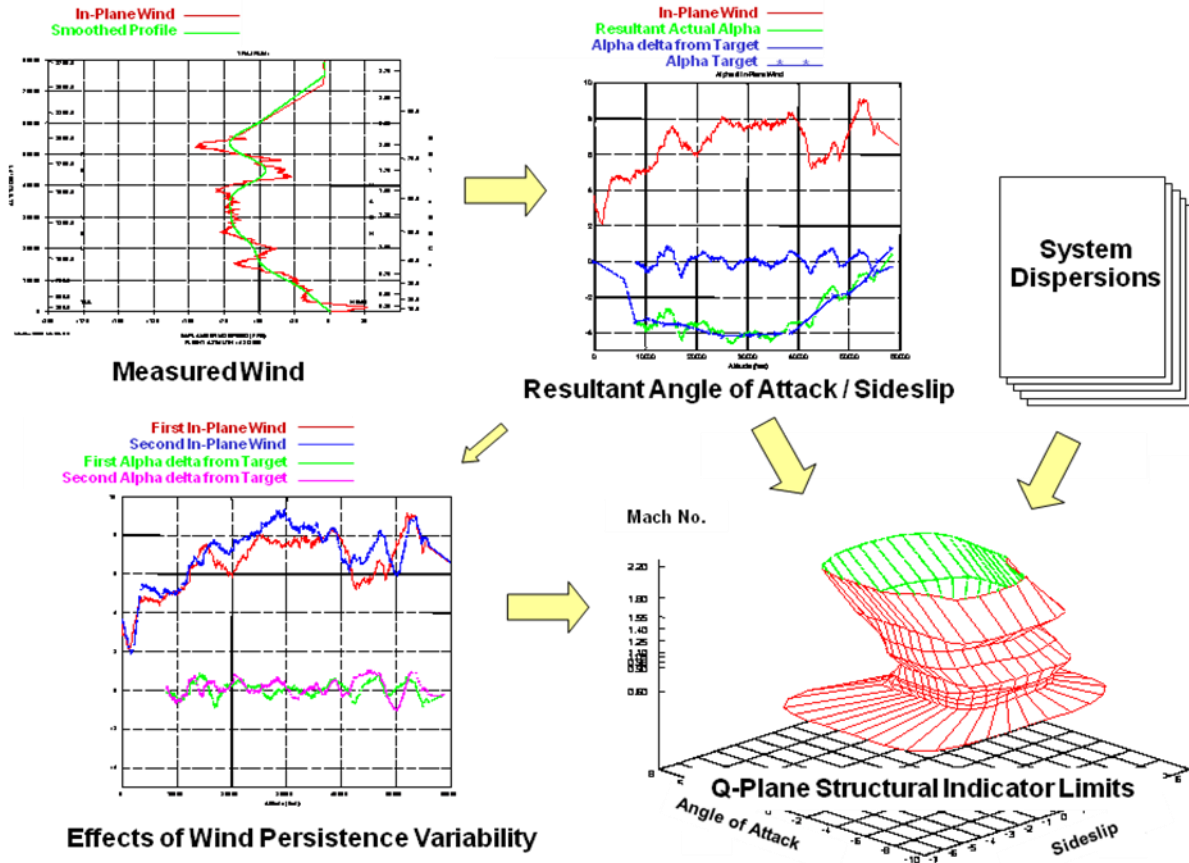

Figure 17-1. Elements of Day of Launch I-Load Update (DOLILU) Process

The biased trajectory profile must be assessed to ensure that when the vehicle flies that profile, the loads will not exceed the structural capability. This requires taking into account the many vehicle parameter variations and the variability of the wind between the time of balloon measurement and launch. These variations are combined statistically as “knock-down” factors on the structural capability to produce load indicator boundaries called Q-planes as a function of altitude. The simulated response of the vehicle using the I-load must lie within these boundaries; otherwise, the launch is no-go. An additional Q-plane check is made using the wind measured by a subsequent balloon closer to launch (L minus 2:00 hours). There is sufficient time before launch to make this verification check, but not to create an updated I-load set.

Figure 17-2 shows some of the process, with the balloon releases indicated by stars along the timeline leading up to launch (L-0). Wind data from the L-3:45 balloon is combined with other information to create the I-load for the onboard flight computers. For redundancy, two organizations independently generate I-load input in parallel, which must compare identically before this flight-critical item is loaded onto the flight computers. The load is then read back to the ground systems for confirmation.

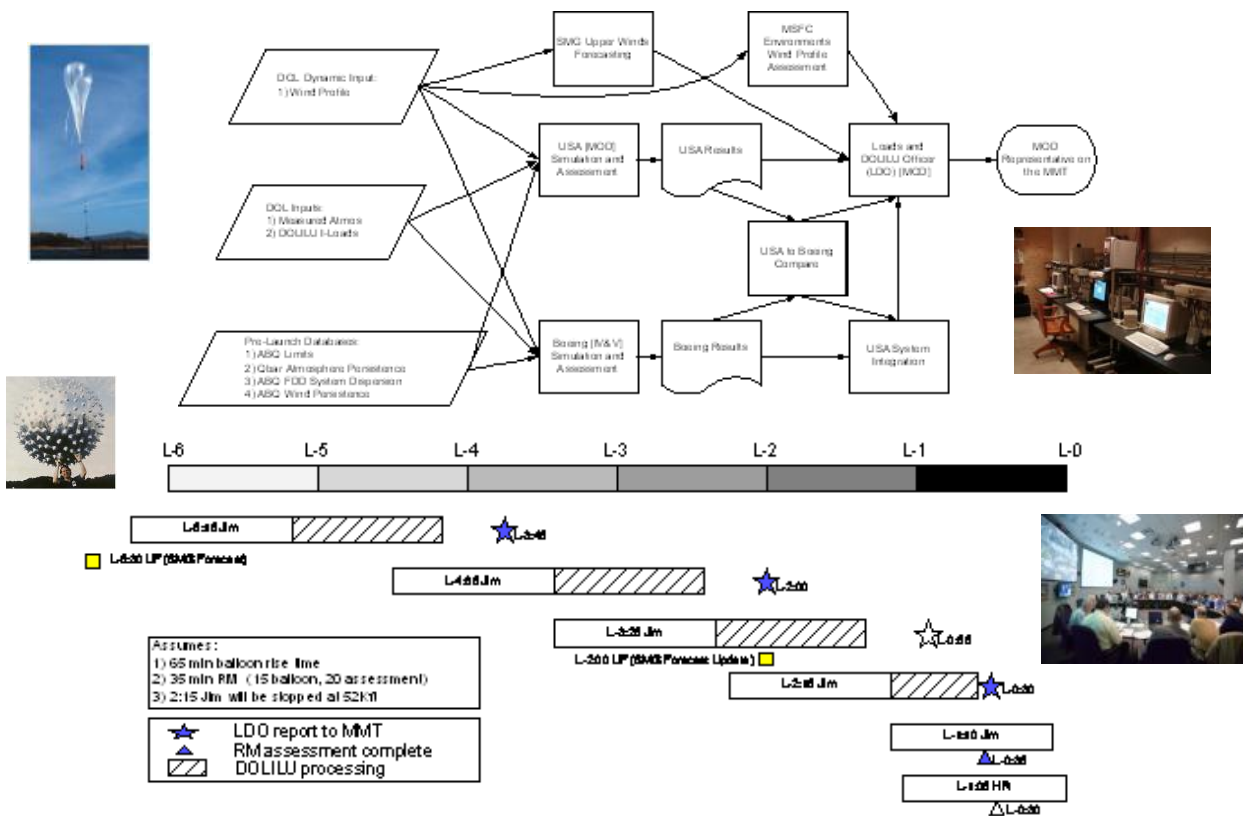

Figure 17-2. Shuttle Day of Launch I-Load Update Data Flow and Timeline

“Some graphics on Figures 17-1 and 17-2 are from a presentation on DOLILU Operations by Brian Harrington, USA, April 20, 2005.”

Although the process has been streamlined from earlier DOLILU approaches, it is clear that the Day of Launch I-Load process requires significant operational effort and complexity. Because the Shuttle is not structurally robust, the program has to pay the operational cost of this process to safely achieve a reasonable launch probability. This is an example of operational complexity not in the original plan.

Design Considering the Total Life Cycle

In the past we typically focused our design activities on the physical performance of the vehicle, then assessed the design for operability, reliability, and cost. What is needed is to design for the total life cycle, which means designing not only for performance, but also (and concurrently) designing for the –ilities and cost.

Figure 17-3 shows a listing of typical metrics of design—those attributes that measure how the system performs, operates, and costs. We can collect them into three categories: (1) *Performance*, which describes how the physical system behaves, (2) *The –ilities*, which includes attributes such as safety, reliability, manufacturability, operability, etc., and (3) *Costs*, which includes various measures of cost. Because our systems are highly interconnected, changing one of these attributes typically will affect the others, within the same category as well as in the other categories.

INTERACTING METRICS OF DESIGN (Typical)

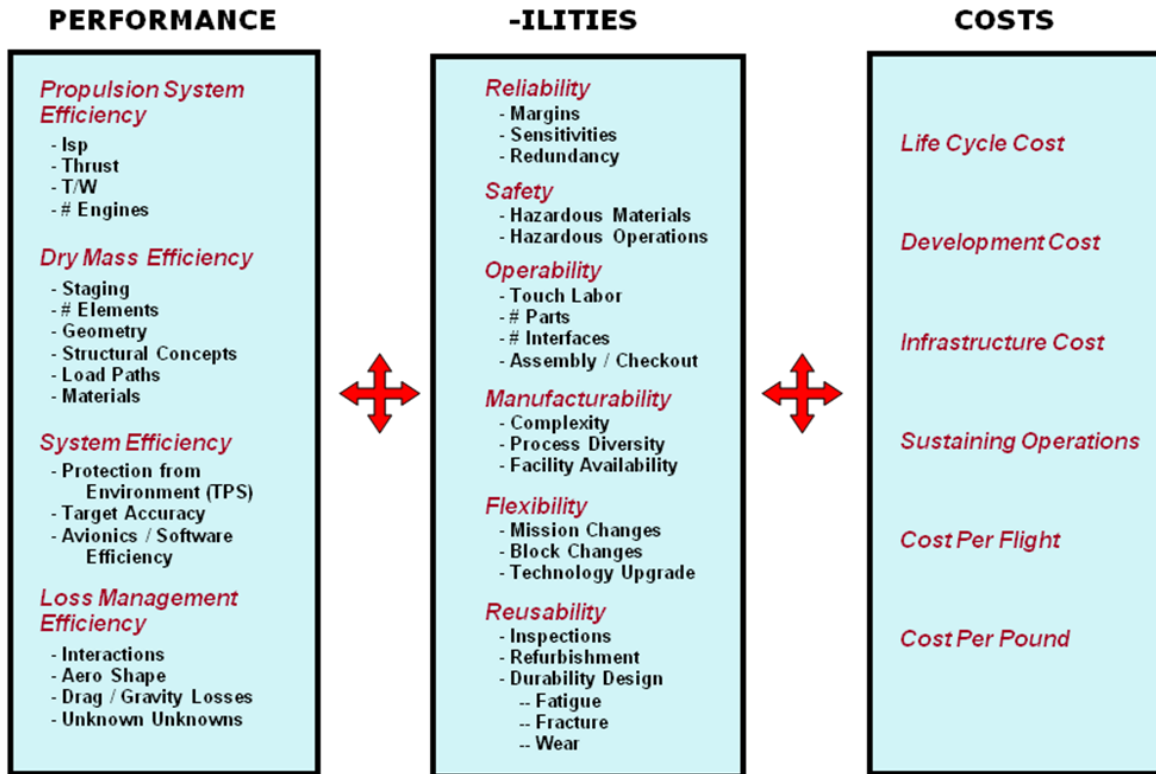

Figure 17-3. Interacting Metrics of Design

In order to obtain a balanced design that meets –ilities and cost goals as well as performance, we must take a systems design/optimization approach across all aspects of the life cycle (Figure 17-4).

- In order to meet operability, cost, and other goals in addition to performance, we must take a systems design/optimization approach across all aspects of the life cycle.
- The goal: While achieving necessary safety, obtain the best balance among performance, the -ilities, and cost.

- In order to meet operability, cost, and other goals in addition to performance, we must take a systems design/optimization approach across all aspects of the life cycle.
- The goal: While achieving necessary safety, obtain the best balance among performance, the -ilities, and cost.

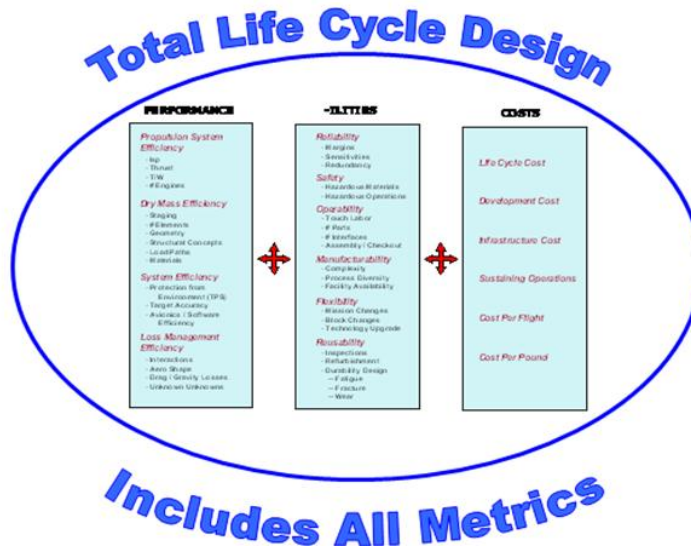

Figure 17-4. Design Considering Total Life Cycle

How We Previously Designed for the -ilities and Cost

The previous design approach is illustrated in Figure 17-5, showing the initial concept being designed iteratively for performance, then subsequent assessments and adjustments being made for -ilities and cost. The -ilities and costs are harder to predict than are measures of physical performance. This process is iterative and sequential, and produces a less than ideal design.

PREVIOUS DESIGN APPROACH Sequential, Iterative,

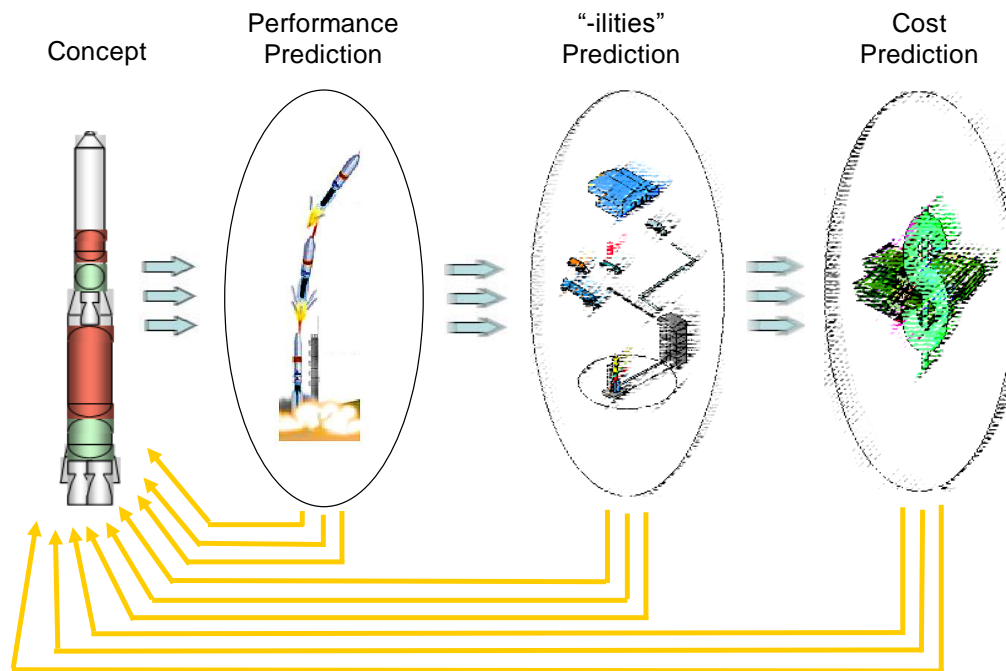

Figure 17-5. Previous Design Approach

How We Should Design for the –ilities and Cost

What is needed is a comprehensive process that addresses downstream –ilities and costs concurrently with performance. As discussed earlier, we describe this as “putting –ilities and costs on the design table”. In order to do this, we need to have functional relationships that provide the designer with measures of costs, operability, reliability, manufacturability, etc., as a function of the design parameters that the designer can choose (Figure 17-6). Another design process improvement represented on the figure is integrated system analysis that where possible unifies analysis of subsystems, design functions, and discipline functions that are currently compartmentalized.

DESIRED DESIGN APPROACH
Concurrent, Comprehensive

Integrated Systems Design

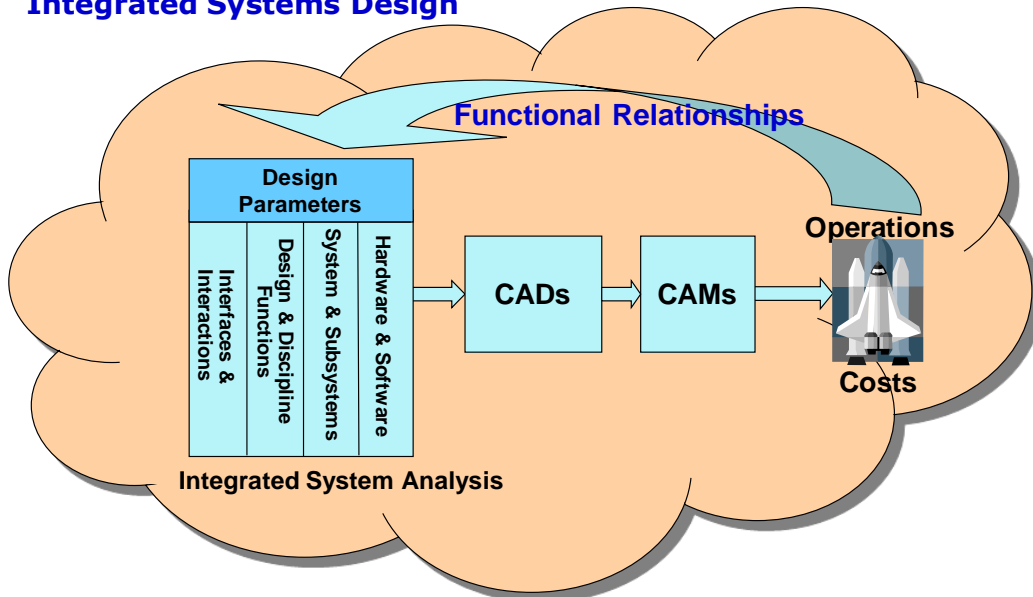

To optimize the total system we need **functional relationships** from the -ilities and costs related back to the design parameters.

Figure 17-6. Desired Design Approach

Obtaining functional relationships between the -ilities/costs and design parameters would enable an ideal concept assessment process illustrated notionally in Figure 17-7. Here the different concepts or designs are mapped into an attribute space (represented simplistically on the figure as three-dimensional) that includes all metrics. Comparisons and directions for improvement would be direct, enabling unified design for the total life cycle.

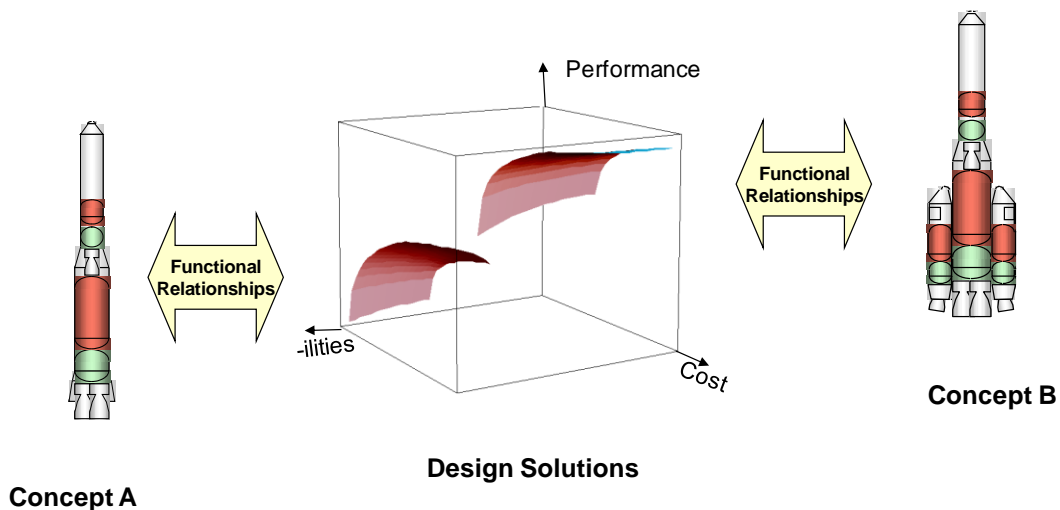

Figure 17-7. Functional Relationships Enable Design Solutions for Multiple Concepts

Obtaining the functional relationships needed for the above process is a challenge—only a few are currently available. Based on historical or other data, people in all technical areas should work to identify functional relationships that connect the –ilities and cost to design variables, thus working toward making the –ilities and cost concurrent “design-to” attributes along with performance.

✦ **A key message from Lesson 17 is:**

Work toward making the –ilities and cost concurrent “design-to” attributes along with performance.

Principle VII: Testing and Verification Have an Essential Role in Development

Testing and verification are central activities in the development process. Their importance is reflected in the large proportion of project cost that is dedicated to testing and verification activities. This principle will be addressed in the following lessons:

- 18. Hardware and Its Data Have the Answers**
- 19. Can Test Now or You Will Test Later**
- 20. Independent Analysis, Test, and Design Keys To Success**
- 21. All Analyses and Tests Are Limited**
- 22. Scaling Is a Major Issue**

Lesson 18: Hardware and the Data Have the Answers

✦ **Read The Hardware and Its Data –They Have The Answers**

🗘 **Don't rationalize what is seen**

🗘 **Look for the hidden message**

The real system is the hardware and software—it is not analysis models or even our mental models of the system. We must look to the actual hardware and software for answers to the actual system behavior.

In developing an engineer's capabilities, there is no substitute for experience with the actual hardware. Hardware experience can be acquired as the hardware is being manufactured and assembled, and during testing—development tests, qualification tests, certification tests, hardware-in-the-loop simulations, etc.—as well as flight experience. Persons working the design/development process should take every opportunity to gain hardware experience, to understand the reality of the actual system.

Hardware inspection observations and data acquired during test and flight are keys to understanding. There is usually more information there than first meets the eye. Plow the data deeply to extract the message. If the data doesn't correspond to your expectations, the initial reaction often is to assume it is bad data. Resist that reaction—the data is usually valid, and it contains a message about the real system. Look for the hidden message and don't rationalize away what is seen.

Examples:

- 51-L Challenger Failure
- Hubble Space Telescope Mirror Aberration
- X-33 Liquid Hydrogen Fuel Tank Failure

51-L Challenger Failure

The failure of the Shuttle on Mission 51-L in 1986 provides an example of the need to intently focus on what the hardware and data is telling us, and not discount anomalies that may be precursors to failures. The 51-L failure and its causes have been extensively documented, and will not be repeated here except to highlight some perspectives relating to the lesson at hand. [Rogers, 1986]

The original design of the SRM field joint had some inherent flaws that were not initially apparent. When the SRM was ignited, the pressure increase caused rapidly-opening deflections at the joint sealing surfaces (Figure 18-1). The sealing surfaces at both the primary and secondary O-ring seals exhibited this characteristic, and although the secondary deflection was smaller than the primary, the two seals did not provide independent redundancy. Putty was applied as a thermal barrier between the facing surfaces of the mated segment insulation. As the segments were joined during assembly and the seals were leak checked, trapped air often caused blow-holes in the putty that created pathways to the joint for the combustion gas. Depending on the extent of the pathways, the response of the specific joint and O-rings, and other variables, the hot combustion gas could impinge on the O-rings and cause heat-affected areas and erosion.

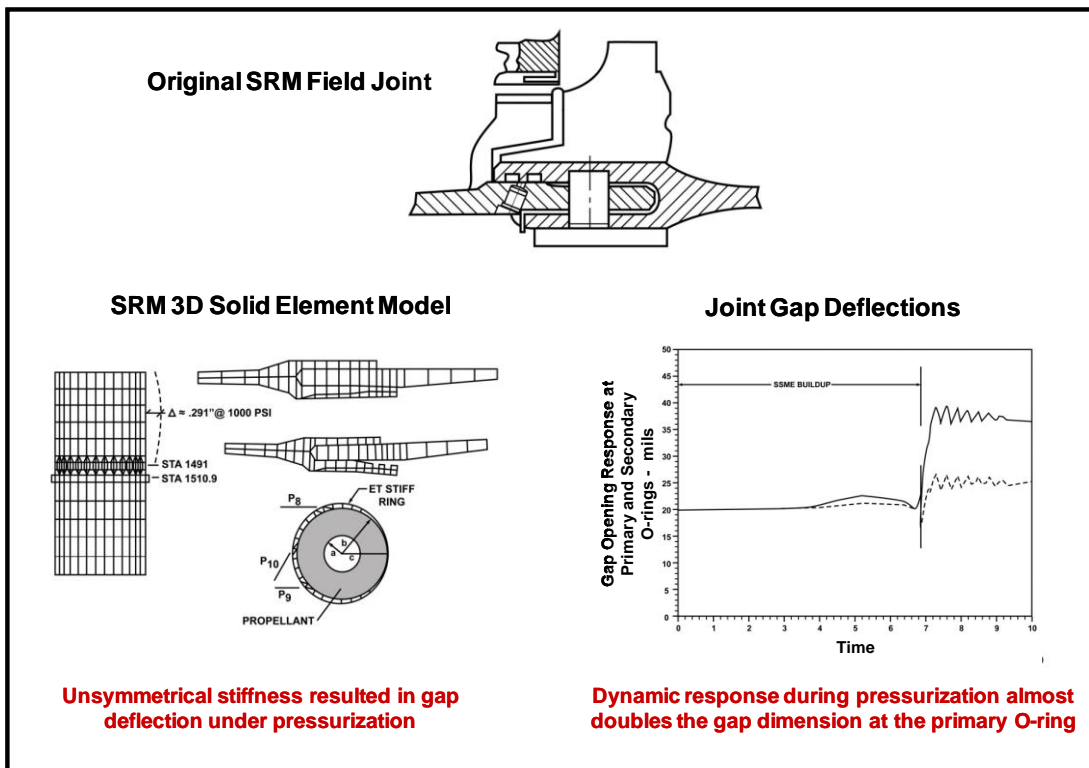

Figure 18-1. STS 51-L SRM Field Joint and Gap Deflections

There had been several occurrences of SRM joint O-ring distress in flights previous to Mission 51-L, where hot gas from SRM combustion had penetrated through breaches in the putty between the segments and impinged on the O-rings. These anomalies were assessed, but as they recurred on subsequent flights, they tended to be rationalized as being within the experience base. This is an example of “normalizing the deviances” and not taking action on impending problems. As a member of the investigating commission, J. R. Thompson commented, “It was winking at us.”

Figure 18-2 is taken from the final report of the commission on the Challenger accident. It was developed by commission staff members to summarize the correlation of O-ring damage experience with temperature. The top display in the figure plots the number of O-ring distress incidents versus temperature. By themselves, these data did not indicate a clear correlation of distress with temperature. But when data from flights with no distress is added, as in the bottom display, a different picture emerges, and the temperature correlation is more evident. The lesson is to consider all information when making decisions.

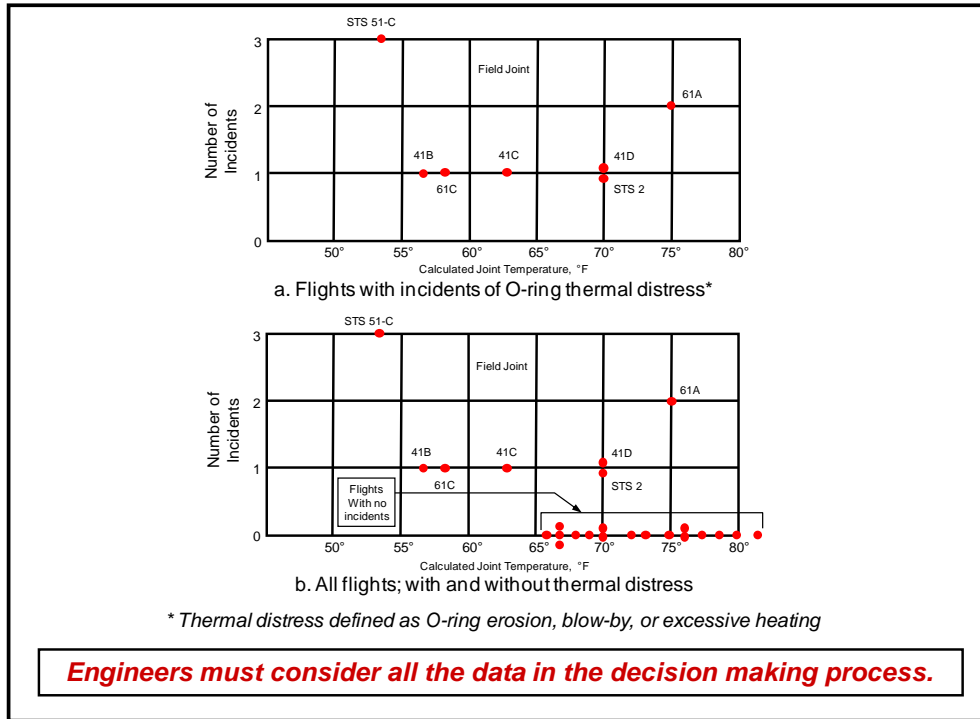

Figure 18-2. SRM Field Joint Flight Data – Thermal Distress Incidents vs. Temperature

Most major failures have more than a single cause, and this was the situation for 51-L. The gap at the clevis-tang joint opened when the SRM ignited and pressurized the case, exceeding the ability of the primary and secondary O-rings to resiliently respond at cold temperatures and maintain the joint seal. In addition, there were factors that contributed to the failure of that specific SRM joint. Although it is not considered good design practice to rely on pressure to actuate O-ring seals, pressure going around and under the O-rings had most likely aided the material resiliency to seal most SRM joints. The O-ring groove tolerances on the SRMs allowed the possibility that both sides of the O-ring could be in contact with the groove, which would have hindered pressure actuation. Furthermore, the relative diameters of the tang and clevis were a factor. When the SRM cases are reused and proof tested, their diameters undergo a slight permanent change. There had been several reuses of the tang-side case on the joint that failed on 51-L, making it likely that the tang surface and clevis surface were in contact, pressing the O-ring into the groove and reducing the likelihood of pressure actuation assistance. (Figure 18-3). The question should have been “What is the real hardware doing?” instead of a reliance on idealized concepts or models.

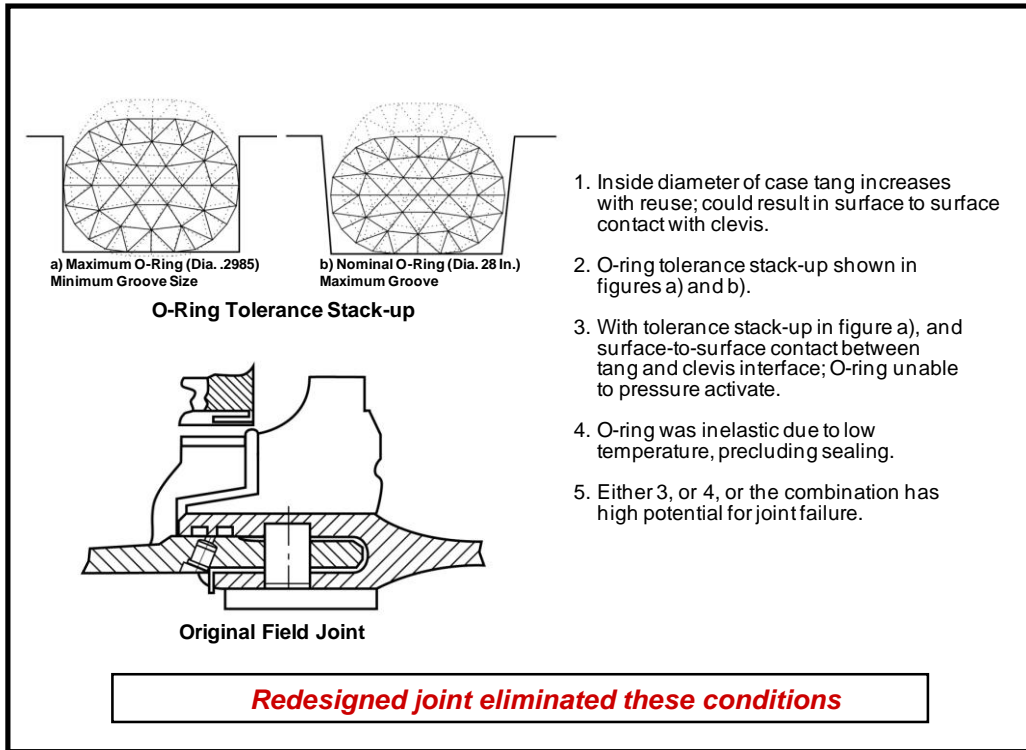

Figure 18-3. STS 51-L Field Joint – O-Ring / Groove Tolerance Effects

Redesign of the SRM joint following the accident corrected its various shortcomings, and produced a design that has multiple layers of protection against a joint breach. [Perry, 1989] These improvements include a tang/clevis capture feature that greatly reduces gap opening at pressurization, improved groove tolerances, better sealing checks, sealed insulation, joint heaters, and better assembly procedures. (Figure 18-4). The redesign has flown successfully ever since, with no indications of seal problems.

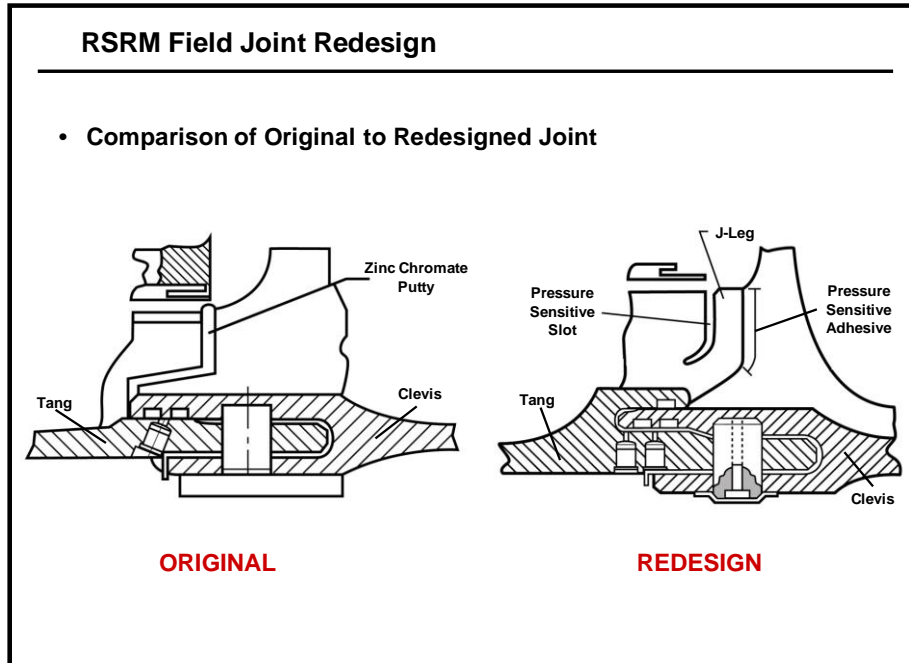

Figure 18-4. RSRM Field Joint Redesign

Hubble Space Telescope Mirror Aberration

The Hubble telescope, see Figure 18-5, was launched in April 1990 on Space Shuttle Discovery (STS-31). Its weight is 24,500 lbs. and the main mirror's diameter is 94.5 inches. The orbit is near circular and at an altitude of 347 miles. Its inclination is 28.5 degrees with a period of 96/97 minutes.



Figure 18-5. Hubble Space Telescope

After the launch it was learned that the main mirror was incorrectly ground. Efforts were taken to determine what could be done to fix the mirror system and how the mirror was incorrectly ground. A method was established to fix the telescope while in orbit, since the telescope was designed so that it could be serviced. So the first servicing mission took place in December 1993 and several instruments and other equipment were installed over 10 days, returning the telescope to full capability.

During the manufacturing of the mirror there were tests to determine the shape of the mirror's surface. Tests with the new "flawless and superior" reflective null corrector device showed the mirror's surface to be perfect. However, during the setup of the mirror and reflective null corrector device, a 1.3 mil spacing error was caused by the intentional placement of washers to make the reflective null corrector device match the laser reflection from a NBS precision metal calibration bar. So whenever the surface was measured it showed perfect when in fact it wasn't.

Other surface tests were made during manufacturing. One was with an inverse null corrector device and the other was a refractive null lens. Both of these indicated that something was amiss. However, the mirror manufacturer, Perkin-Elmer Corp., discounted these results in favor of the "flawless and superior" method; see reference [Allen, 1990].

From this experience it can be seen that, see reference [Chapman, et.al., 1997]

1. Questionable test results were not understood and they were discounted.
2. There was no requirement for an independent check.
3. Didn't compare to the Eastman Kodak mirror and select the best.
4. No system test required.
5. NASA didn't follow through with insight-oversight.

X-33 Liquid Hydrogen Fuel Tank Failure

Single Stage to Orbit vehicles require a very high mass fraction for performance efficiency in order to reach orbit. One method for achieving this structural efficiency is using the technology of composite cryogenic propellant tanks, which is a new technology for achieving the high mass fraction. The X-33 fuel tank was designed to develop and demonstrate this technology. The X-33 hydrogen tank failed during verification testing under cryogenic conditions. The tank wall design was an inner skin of 13 composite plies with a layup pattern, a 1½ inch honeycomb core for insulation, and outer skin (face sheet) of 7 plies as shown on Figure 18-6.

X-33 LH₂ Tank Failure Investigation Findings

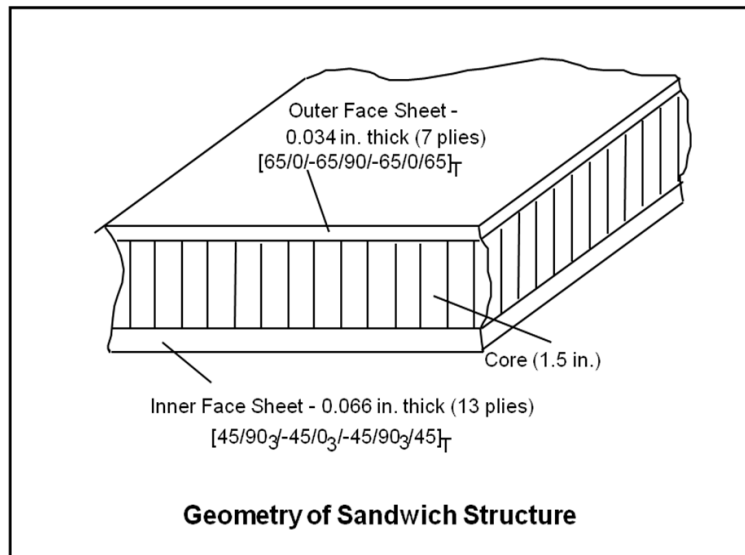

Figure 18-6. Geometry of Sandwich Structure of X-33 Fuel Tank

The design approach of the outer and inner sheet over the honeycomb had problems during manufacturing. The process was verified using a 2 foot square panel, and then the first full panel was made. When it was taken out of the autoclave and laid on the floor the outer panel delaminated. This was investigated by a special panel. It was realized that there was a lowering of the qualities of the adhesive used to fasten the sheets to the honeycomb in the full scale article due to the extended time between adhesive application and autoclave cure (the adhesive *out-time*). The process was reworked. Also, everyone knew and was worried about cryopumping during flight causing a failure. Therefore, the panel also recommended that the TRL level be reduced and that the cryogenic verification test of the flight tanks have special instrumentation to ensure no cryopumping and other potential problems.

The program proceeded to build the two flight hydrogen tanks and brought them to MSFC for the cryogenic and structural loads verification tests. The articles were all instrumented with the special instrumentation including thermal and strain gauges and pressure gauges in the honeycomb. The first test was conducted using liquid hydrogen with the flight tank pressurization system and appropriate flight-like loads. After the test the tank was drained and in the depressurization process the outer face sheet was blown off. The basic cause was not the expected cryopumping but was caused by the hydrogen gas penetrating the inner skin, due to micro cracking of the inner composite panel, filling the honeycomb core with liquid hydrogen. After the test, the tank was drained of liquid hydrogen, and the hydrogen trapped in the honeycomb warmed up and blew the outer skin off the tank (Figure 18-7).



Figure 18-7. Failed X-33 Fuel Tank

The cause of the gas penetration into the honeycomb was micro cracking of inner face sheet due to the thermal strain between the outer face sheet being at ambient and the inner face sheet being at -420 degrees plus the stress introduced by the tank internal pressure. Figure 18-8 shows plots of the pressure variation in the tank and in the honeycomb at various locations. Notice the heavy line is the tank internal pressure actual profile during the test. The lighter lines are pressures at various locations in the honeycomb. Notice that the honeycomb pressure does not track the internal tank pressure but starts rising when the micro cracking starts. As the tank was drained the honeycomb pressures starting coming down to the point that when the internal pressure was low enough the micro cracks sealed and the honeycomb pressures continued to rise, until the outer skin blew off. This phenomenon was duplicated on small panel testing at Southern Research Institute and by LaRC engineers using analytical fracture analysis of composites.

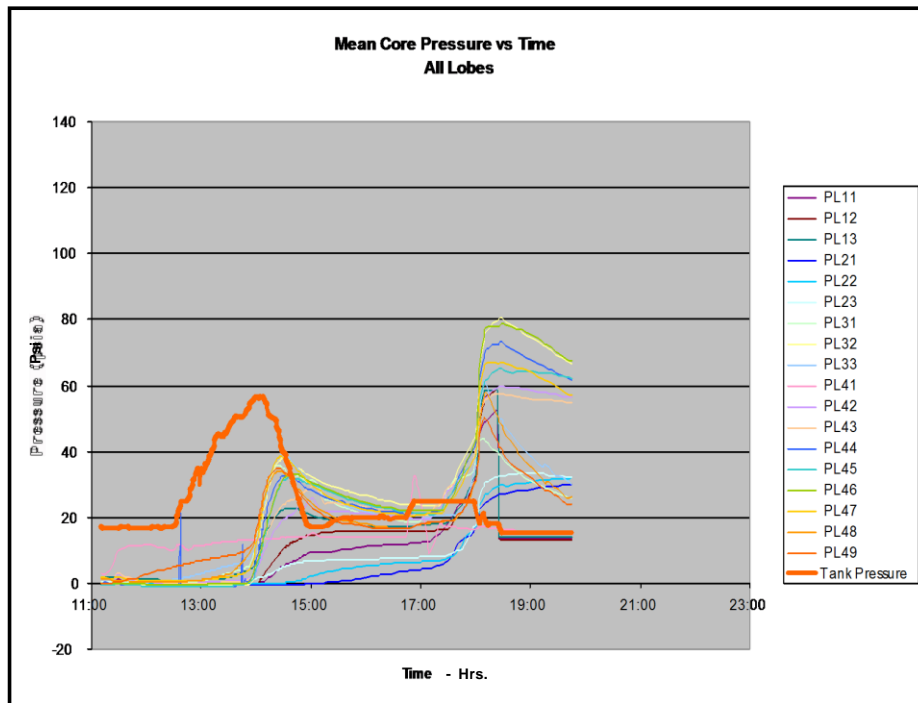

Figure 18-8. Pressures in Failed X-33 Fuel Tank

The X-33 LH₂ Tank Failure Investigation findings were:

- Scaling of manufacturing processes is a major verification issue.
- Adhesive out-time before autoclaving lost strength.
- Micro-cracking of composites was not well understood before committing tank to design and manufacturing.
- Design of attachments to take out the thrust load (thrust busters) is a major design and manufacturing challenge.
- Verification of new technologies generally requires full scale testing.

✦ **A key message from Lesson 18 is:**

***There is no substitute for experience with the actual hardware.
Look closely at what it tells you.***

Lesson 19: Test Now or You Will Test Later

✦ **Testing is an essential element of the design process.**

- ✦ **"Test what you fly, fly what you test." - Jack Bunting, Lockheed Martin**
- ✦ **Development and verification testing is at the heart of design.**

- ❏ **Testing should be a building block approach, i.e., subscale and full scale, component and systems.**
- ❏ **Different types of testing are needed: Development, Qualification, Verification, Certification, Acceptance.**
- ❏ **Tests are no better than the assumptions used.**

Testing is mandatory for all high performance systems. As the title of the lesson says, “You can test now or you will test later”. This makes the point that the initial time a product is operated will be first and foremost a test if adequate testing has not been accomplished already. In addition, no test can fully duplicate all the combined environments of operations, thus for most systems the first few uses are indeed development tests, since this is the first time all the combined environments have been experienced. This is especially true for launch vehicles that must traverse through a varied and complex set of natural and induced environments. The following discussion emphasizes some of the basic principles of testing and verification with the overarching principle “Testing is an essential element of the design process.”

Jack Bunting of Lockheed Martin has said “Test what you fly and fly what you test.” Others have said; “Development and verification testing is at the heart of design.” Developmental testing provides understanding of the system before it is built so that those characteristics can be incorporated into the design, while verification testing determines if the as built design meets the system requirements. Testing is best accomplished using a building block approach so that the elements and the system as well as system interactions are understood. In today’s world cost restrictions are eliminating many of the building block tests and/or the final system tests. This places more risks on the first flights and can result in design changes after hardware is built which within itself is as costly. This principle has been demonstrated in most space flight projects. Avionics components and mechanisms have at least six types of tests: development, qualification, verification, certification, assurance, and acceptance. Finally any test is based on a set of assumptions; therefore, no test is better than the assumptions used in the test hardware and the test conditions and environments.

Types of Tests

The following is a list of the types of tests generally used on space systems.

1. Development Tests
2. Qualification Tests
3. Certification Tests
4. Process Assurance Tests
5. Acceptance Tests
6. Systems Integration and Verification Tests
7. Flight Readiness Firing
8. Other Tests (Flight tests, etc.)

Development Tests are tests conducted throughout the design cycle of a project and are used to get basic information about the characteristics of the system, so that the design incorporates these characteristics and can handle the situations induced. Developmental

tests include wind tunnel testing, scale model dynamic testing, thermal testing, materials testing, component vibration testing, acoustical testing, etc. and are fundamental in understanding systems. Component vibration tests and thermal vacuum tests uncover design flaws that can be corrected before final design is completed.

Qualification Tests are generally of flight type or flight hardware that are tested to at least 3 sigma levels of the environments with the component carrying out certain flight type functions. Minor changes are easily made after these tests and if changes are required, the tests are generally repeated.

Certification Tests are usually for things like liquid propulsion system engines that can be ground tested under flight conditions using both flight hardware and flight operational procedures. For example certification of the Space Shuttle Main Engines requires that two identical engines be tested under flight profiles and operational procedures for 20,000 seconds. Some of the major problems experienced during certification testing will require hardware changes and a repeat of the certification testing or flying the engines under waivers and operational constraints.

Process Assurance Tests are generally for solid rocket motors and pyrotechnic devices. Hardware like this is either very costly or is destroyed in the tests so lifecycle testing is not appropriate. The test program usually consists of a few (say 5) motors or devices before flight. During the operational program, a motor or device is periodically pulled from the manufacturing line and tested to ensure that the build process is still meeting requirements.

Acceptance Tests are usually of avionics and mechanisms where each unit is tested when it comes off the production line. The tests are not of full flight duration and are at reduced environments. This testing is to eliminate manufacturing or infant mortality flaws. Flight liquid propulsion engines are tested in this manner using a short duration hot firing of the engine. At various times in space programs the engines attached to flight stages are ground hot fired for short durations to understand the interaction of the engines with the main propulsion systems.

Systems Integration and Verification Tests are of many types to checkout the integrated system, validate analytical models and induced environments. The following is a partial list of integrated tests for launch vehicles.

- Hardware integration and checkout
- Integrated ground vibration (dynamic) tests to validate dynamic models
- Main propulsion tests to understand the integration of engines with the main propulsion system elements and software.
- Integrated avionics tests using hardware/software components.
- Large scale wind tunnel verification testing for aero and thermal environments.

We can also do **Flight Readness Firings** on the launch pad, of short duration burn time, of launch systems with liquid propulsion systems. This is done to check out the MPS of any major changes made from prior configurations. One final test program is the **Flight Test** programs of launch vehicles, where the first two or three flights are test flights that are heavily

instrumented in order to determine combined environments and interactions that are that are not possible to accomplish in the above discussed tests. Flight testing has uncovered many major problems that were not found during the above tests. The following is a discussion of some major tests of previous space systems.

Examples:

- Saturn V Dynamic Tests
- Space Shuttle Dynamic Tests
- Summary of Dynamic Test Impacts
- Space Station Static and Dynamic Tests

Saturn V Dynamic Tests

Saturn V was dynamically tested as both scale models and full scale flight-like hardware. The full scale dynamic test was of the total system and of each stage of launch vehicle flight in free-free boundary conditions. A hydraulic bearing was developed to create a free-free boundary in the lateral planes. Liquid hydrogen was simulated using ping-pong balls. Water was used to simulate liquid oxygen. The on-pad modes were verified with the famous “Tennis Shoe Test” where engineers went to the top of the assembly facility and excited the first bending mode by pushing with their feet. Tennis shoes were worn so as not to damage the Command / Service Module.

Several issues were uncovered in the free-free full scale dynamic test that included excessive rotational deflections of the rate gyro attachment plate (as described in Lesson 5). This required moving the rate gyro to smaller deflection area in the Instrument Unit (IU). Overall there was good correlation of all test lateral modes with analytical predictions. A table shown at the end of this section contains all the major findings in the dynamic tests conducted at MSFC. [Grimes et. al., 1979]

Space Shuttle Dynamic Tests

Figure 19-1 shows the Space Shuttle Orbiter being moved into the dynamic test stand for mating with the External Tank and the Solid Rocket Boosters. Also shown are the various dynamic tests conducted for Shuttle and the basic characteristics of the complex Shuttle configuration consisting of four bodies connected with forward and aft interface joints. This resulted in approximately 200 bending modes below 20 Hz. [Jewell et. al., 1980]

Shuttle Dynamic Tests



- Space Shuttle Dynamic Tests uncovered several modeling problems.
- There were four model sets for the dynamic tests.
 1. $\frac{1}{8}$ scale model
 2. $\frac{1}{4}$ scale model
 3. LOX Tank Modal
 4. Full Scale
- Multi-bodies connected with point interfaces (struts) have many dynamic coupled bending modes. Shuttle has 200 in the range of 0-20 Hz.

Figure 19-1. Shuttle Orbiter Being Installed Into Dynamic Test Stand

Initially it was deemed that a full scale dynamic test was not needed and in addition not doing the test would save the program at least \$20M. The method used to justify the test was based on risks and their consequences on the various disciplines that used the dynamic vehicle characteristics for response and stability design. Typically these disciplines are:

1. Control response and stability
2. Dynamic response and loads
3. Aeroelasticity
4. Pogo

Figure 19-2 illustrates how various dynamic tests increase confidence and reduce the flight risk for the pogo discipline. Similar charts were developed for the other above listed disciplines. Combination of the four resulting risk reductions and the impact on the program complexity and risk if the test was not completed, resulted in the dynamic test being justified and accomplished.

Shuttle Dynamic Tests

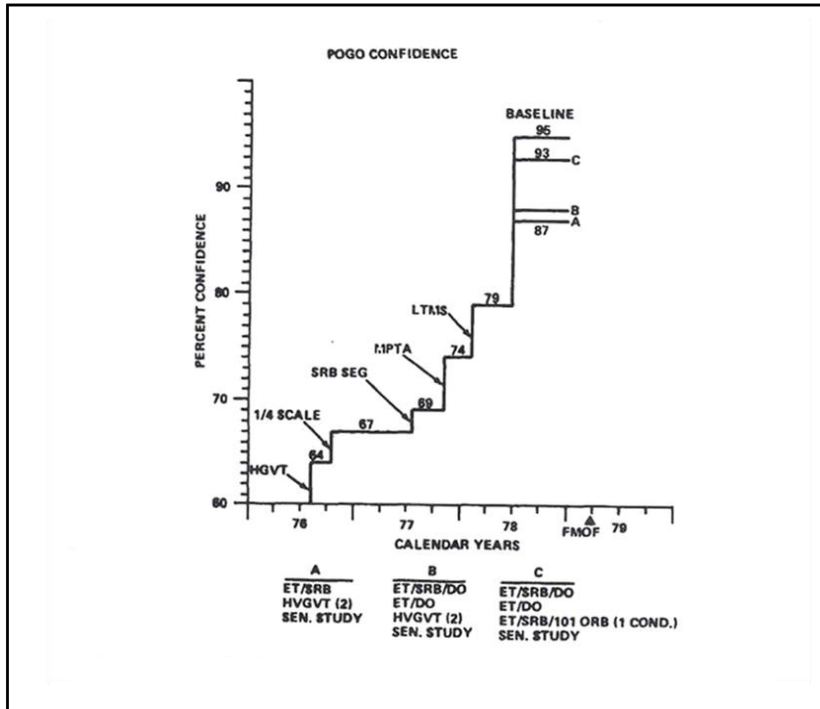

Figure 19-2. Pogo Confidence Factor Increase with Tests

One important test for validation of the pogo analytical model used for stability analysis and pogo solution design was full scale hydroelastic test of the LOX tank. This validated model was then combined with the overall vehicle model validated by the MVGVT. This was a very interesting test of the full scale LOX tank filled using water to simulate various flight conditions. The test configuration is shown on Figure 19-3. The first test condition was a full tank, and when the hydroelastic mode was excited there was basically no damping in the mode. This was the case for tests at lower fill levels until the tank was about two-thirds full, at which time the damping became the expected value.

Shuttle Dynamic Tests: LOX Tank Modal

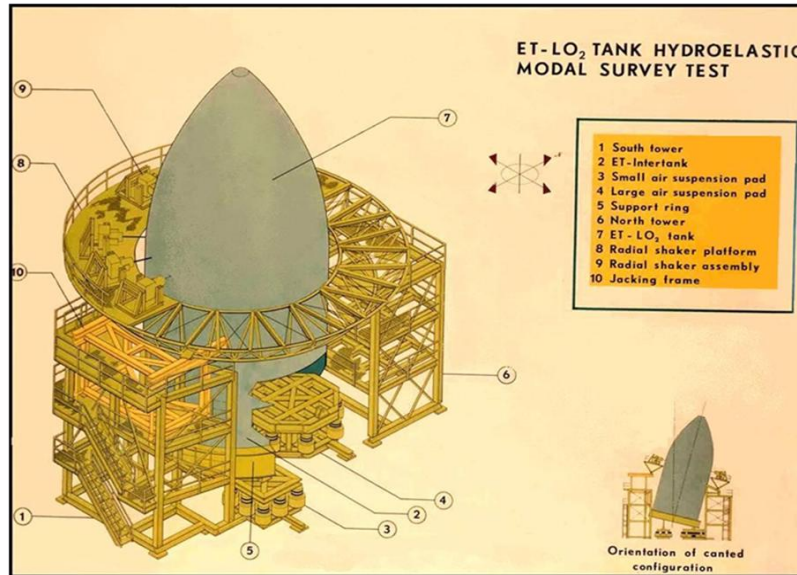

Figure 19-3. Shuttle LOX Tank Hydroelastic Test Configuration

The plot of damping versus fill level on Figure 19-4 illustrates the results just discussed. Once the model of the test condition was validated, then LOX instead of water was used in the analytical model. The use of LOX instead of water decoupled the structure from the fluid mode and no flight fix was required. The results illustrate the sensitivity of dynamic coupling and the need to conduct building block testing approaches. [McComas, 1980]

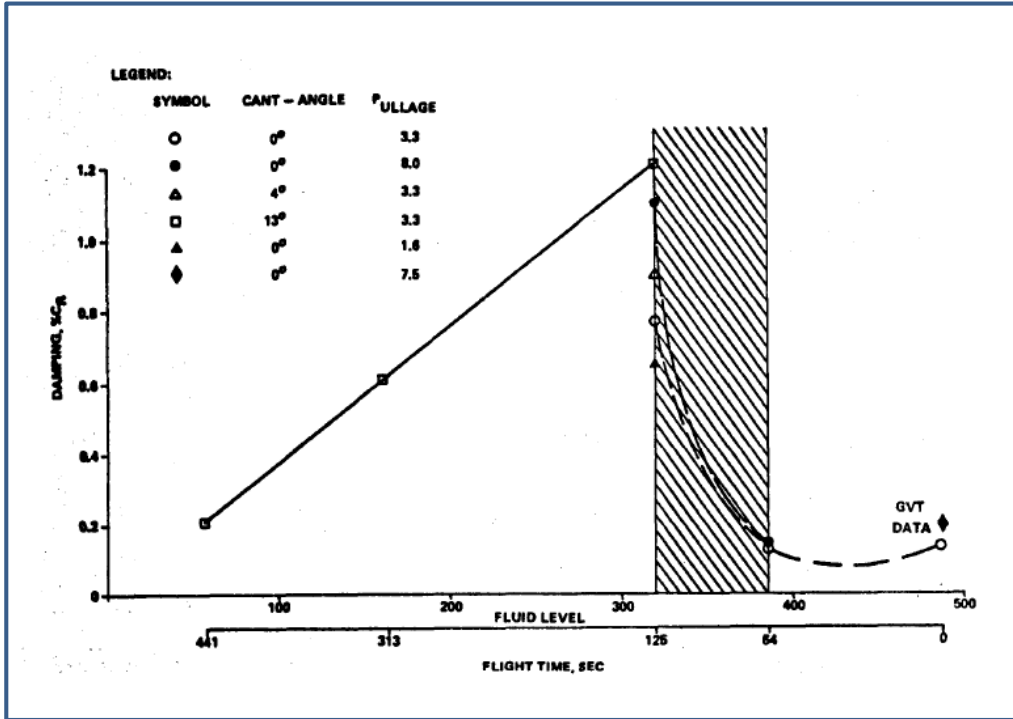

Figure 19-4. Shuttle LOX Tank Propellant Damping

Summary of Dynamic Test Impacts

The following tables (Figure 19-5) summarize dynamic testing experience and its impacts on the projects. [Jewell et. al., 1980] [Emero, 1979] Shown in the first column is the test program, with the second column being the problem discovered. The hardware impacted is the third column and the consequence if not discovered is the last column. The first item is the local deflection of the Saturn V IU mentioned earlier and the potential impact of a bending mode control coupling instability if it had not been discovered.

Dynamic Testing Impacts (a)

| TEST PROGRAM | PROBLEMS DISCOVERED | HARDWARE IMPACTED | CONSEQUENCES IF NOT DISCOVERED |
|--------------|--|---|--|
| SATURN V DTV | LOCAL ROTATION OF THE FLIGHT GYRO SUPPORT PLATE. VEHICLE DYNAMIC SHEARS AND MOMENTS DEFORMED SUPPORT PLATE. THE MATH MODEL UNDER PREDICTED THIS DEFORMATION BY 135 PERCENT. | THE GYROS WERE RELOCATED TO THE BOTTOM OF THE SUPPORT PLACE WHERE THE LOCAL ROTATION WAS MUCH LESS. THIS REQUIRED WIRE HARNESSSES OF NEW LENGTH. THE FLIGHT CONTROL FILTER NETWORK WAS REDESIGNED | FLIGHT CONTROL INSTABILITY RESULTING IN LOSS OF VEHICLE. |
| MARL | DESIGN DEFICIENCY IN THE IU STABLE PLATFORM. COUPLING BETWEEN THE STABLE PLATFORM AND THE RING MODES OF THE IU PROVIDED A MECHANISM FOR ACOUSTICALLY DRIVING THE PLATFORM ACCELEROMETER AGAINST THE STOPS. | SHORT CHANNEL STIFFENERS WERE ADDED TO AS 501 ON THE PAD. DAMPING MATERIAL AND A SOFTWARE "REASONABLENESS" TEST WERE ADDED LATER IN THE PROGRAM. | LARGE GUIDANCE ERRORS THAT COULD CAUSE LOSS OF LUNAR MISSION. |
| SATURN V DTV | DESIGN DEFICIENCY IN THE CSM INTERFACE. THE SINGLE TORSIONAL SWAY BRACE PRODUCED UNPREDICTED HIGH COUPLING BETWEEN COMMAND MODULE TORSIONAL MOTION AND S-1C ENGINE DEFLECTION. | ADDITIONAL TORSIONAL SWAY BRACES WERE INSTALLED ON AS 501 ON THE PAD. SUBSEQUENTLY, THE F 1 ENGINES WERE REDRIFICED TO REDUCE LOADS AT ENGINE CUTOFF. AN ENGINE PRECANT PROGRAM WAS IMPLEMENTED TO MAINTAIN STRUCTURAL INTEGRITY IN CASE OF ENGINE OUT. | STRUCTURAL FAILURE OF THE CSM INTERFACE WITH LOSS OF VEHICLE AND POSSIBLE CREW LOSS. |
| SATURN V DTV | DESIGN DEFICIENCY IN THE SPS TANK SUPPORTS. UNEXPECTEDLY HIGH LOCAL RESONANT COUPLING WAS DETECTED BETWEEN SPS TANK AND BULKHEAD SUPPORT. | THE UPPER SUPPORT BRACKET FOR THE SPS TANKS WAS REDESIGNED TO ELIMINATE A STRONG TANK CANTI-LEVER MODE. | HARDWARE FAILURE RESULTING IN LOSS OF MISSION AND POSSIBLE CREW LOSS. |
| SATURN V DTV | HIGH LOX AND FUEL DYNAMIC TANK BOTTOM PRESSURES. THESE PRESSURES WERE UNDER PREDICTED BY A FACTOR OF 2. THE SIGNIFICANCE OF THESE PRESSURES WAS NOT UNDERSTOOD UNTIL AFTER POGO OCCURRED ON AS 502. | THE HIGHER TANK PRESSURES CONTRIBUTED TO THE S 1C POGO. | POTENTIAL LOSS OF VEHICLE AND CREW DUE TO POGO. |

Dynamic Testing Impacts (b)

| TEST PROGRAM | PROBLEMS DISCOVERED | HARDWARE IMPACTED | CONSEQUENCES IF NOT DISCOVERED |
|----------------------|---|---|---|
| SATURN V DTV | HIGH 18 HZ S-1C CROSSBEAM MODE GAINS. DTV DATA SHOWED THAT AN ACCUMULATOR SHOULD NOT BE USED ON THE INBOARD ENGINE. | ELIMINATION OF A PLANNED INBOARD ENGINE ACCUMULATOR. | POTENTIAL LOSS OF VEHICLE AND CREW DUE TO POGO BETWEEN AN 18 HZ ACCUMULATOR MODE AND THE 18 HZ CROSS-BEAM MODE. |
| SATURN V SHORT STACK | STRONG PITCH/LONGITUDINAL COUPLING CAUSED BY THE LUNAR MODULE INCREASED THE S-1C POGO GAIN FACTOR BY 30 PERCENT. THIS EFFECT COUPLED WITH THE TANK PRESSURE UNDERPREDICTION WAS THE REASON AS-502 POGO WAS NOT PREDICTED. | DEVELOPMENT AND INSTALLATION OF THE OUTBOARD LOX ACCUMULATORS. | POGO INSTABILITY WITH POTENTIAL LOSS OF VEHICLE AND CREW. |
| SATURN V MINI A/C | THE MECHANISM TRIGGERING S-II POGO WAS DEFINED. COUPLING BETWEEN THE FIRST FOUR LOX TANK HYDROELASTIC MODES WHEN THEY COALESCED WITH THE 16 HZ CENTER ENGINE CROSSBEAM MODE PRODUCED THE POGO INSTABILITIES. | AN ACCUMULATOR WAS DEVELOPED FOR THE CENTER ENGINE. A BACK-UP CUTOFF SYSTEM WAS ALSO DEVELOPED. THE ACCURATE MATH MODEL DEVELOPED DURING THIS TEST SUPPORTED EXTENSIVE THRUST STRUCTURE DESIGN MODS ON SUBSEQUENT VEHICLES WITHOUT FURTHER TESTING. | POGO INSTABILITY WITH POTENTIAL LOSS OF VEHICLE AND CREW. |
| SKYLAB ATM TEST | STRONG CROSS COUPLING BETWEEN LONGITUDINAL AND LATERAL MOTIONS INDICATED A POSSIBLE STRUCTURAL FAILURE AT S-1C CUTOFF. | A 1-2-2 ENGINE CUTOFF HARDWARE AND SOFTWARE MOD WAS DEVELOPED TO REDUCE THE LONGITUDINAL INPUT TO THE ATM. HARDWARE REDESIGNS WERE LAID OUT IN CASE THEY WERE PROVEN NECESSARY BY FURTHER STUDY. | HARDWARE FAILURE WITH POTENTIAL LOSS OF MISSION. |
| SKYLAB MODAL SURVEY | THE STRONG CROSS COUPLING IN THE ATM PROVED TO BE ATTENUATED RATHER THAN AMPLIFIED BY THE WAY ATM CROSS COUPLING REACTED THRU VEHICLE INTERFACE. | TEST OF THE TOTAL SKYLAB LAUNCH CONFIGURATION PROVED THE 1-2-2 FIX WAS ADEQUATE AND THAT NO HARDWARE CHANGES WERE REQUIRED. | THIS TEST SAVED A POSSIBLE REDESIGN OF THE ATM BY VERIFYING STRUCTURAL INTEGRITY UNDER THE 1-2-2 CUTOFF. |

Dynamic Testing Impacts (c)

| TEST PROGRAM | PROBLEMS DISCOVERED | HARDWARE IMPACTED | CONSEQUENCES IF NOT DISCOVERED |
|-----------------------|---|--|--|
| SHUTTLE MGVGT | SRB MOUNTED RATE GYROS EXHIBITED ABNORMALLY HIGH TRANSFER FUNCTIONS. THE RATE GYROS MOUNTED ON THE FORWARD SRB RING FRAMES RESONATED AT LOCAL FREQUENCIES AND HIGH GAINS, WHICH WERE CRITICAL TO FLIGHT CONTROLS. | STRUCTURAL REDESIGN WAS REQUIRED TO STIFFEN SRB RING FRAME, WHICH REVISED THE LOCAL RESONANT FREQUENCIES AND REDUCED THE GAIN. | FLIGHT CONTROL INABILITY AND POSSIBLE LOSS OF VEHICLE. |
| SHUTTLE MGVGT | AXIAL SSME FREQUENCIES AND MODE SHAPES DID NOT CORRELATE WITH PRETEST ANALYSIS. A HALF SHELL DYNAMIC MATH MODEL USING SYMMETRY WAS USED IN THE PRE-TEST ANALYSIS. | A NEW THREE DIMENSIONAL ASYMMETRIC MATH MODEL OF THE SSME ENGINES AND THRUST STRUCTURE WAS REQUIRED. NO HARDWARE CHANGES WERE NECESSARY. | POGO STABILITY ANALYSES WOULD HAVE BEEN SUSPECT. |
| SHUTTLE MGVGT | TEST RATE GYRO VALUES SHOWED GREATER RESPONSE VARIATIONS THAN ANALYSIS. RESPONSE VARIATIONS BETWEEN RGA'S WERE MUCH LARGER THAN THOSE USED IN THE ANALYTICAL STUDIES IN DETERMINING THE REDUNDANCY MANAGEMENT (RM) TRIP LEVELS. | RM SOFTWARE TRIP LEVELS AND CYCLE COUNTER LEVELS WERE INCREASED. THE FAULT ISOLATION ROUTINE WAS MODIFIED TO INHIBIT KICKING OUT RGA'S AND ACC'S AFTER FIRST SENSOR FAILURE. (FOR STS-1 FLIGHT ONLY; OTHER FLIGHTS WILL BE EVALUATED.) | FLIGHT CONTROL INSTABILITY AND POSSIBLE LOSS OF VEHICLE. |
| SHUTTLE QUARTER SCALE | INTERNAL SRB PRESSURE EFFECTS ON STIFFNESS OVER PREDICTED. | LOAD IMPACTS WITH MINOR REDESIGN OF INTERFACE BACKUP STRUCTURE. | POTENTIAL FAILURE OF INTERFACE AND LOSS OF VEHICLE. |

Figure 19-5. Dynamic Testing Impacts

Space Station Static and Dynamic Tests

It is a requirement that all payloads flown on the Space Shuttle must be dynamically tested to ensure human flight safety. Accomplishing this test for the Space Station modules required that there be a solid fixture to provide a very rigid attachment for the Orbiter payload bay attach hardware. This heavy steel fixture was anchored in 20 ft of concrete so that it would not move and therefore establish accurate boundary conditions for the payload. The test setup is shown on Figure 19-6. This fixture was applied to resolve any issues related to the indeterminacy of the payload attachment to the Shuttle Orbiter. It provided correct simulation of the boundary conditions between the payload and the Orbiter attachment. The tests provided data to verify dynamic models that were used in design to ensure crew safety. [Author's working files]

Space Station Static/Dynamic Test

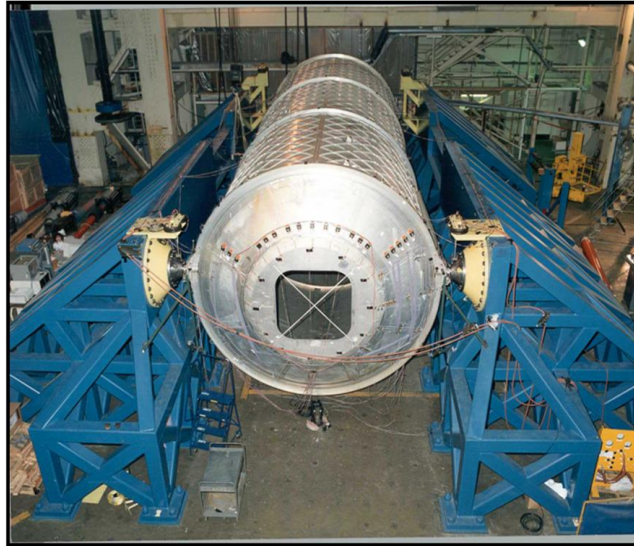

Figure 19-6. Space Station Module Test Setup

✦ A key message from Lesson 19 is:

Test what you fly.

Fly what you test.

Lesson 20: Independent Analysis, Test, and Design Keys to Success

- ✦ Complex systems require independent analysis, test, and design; this provides in-depth insight.
 - ☒ Space Systems are so complex, no one analysis or test can provide all of the answer.
 - ☒ The creativity of the human mind is the source of our solutions. Initially we need to hypothesize and assess various solutions.
 - ☒ We must be open to other insights. (Senge's advocacy/inquiry).

During design and development, some problems that are encountered are out of our experience band. This happens in situations where there are high power densities and when the system limits are expanded. In rocket propulsion systems, effects of high chamber pressures and temperatures along with reduced size (reduced weight) are examples where

problems can be expected. As a result, independent analyses, tests, and designs are needed to provide insights to avoid catastrophic events. In most cases the physics are so complex no one analysis or test can provide all the solutions. To achieve an understanding of complex situations, it takes multiple analyses, tests, and especially the creativity of the human mind. In this process, engineers must be open to the insights and questions of all participants. It takes a combination of human minds to put together these highly interactive complex puzzle solutions.

Examples:

- SSME Whirl Solution
- SSME LOX Pump Spalled Bearings
- SSME Main Oxidizer Valve Buzz Solution

SSME Whirl Solution

Both the fuel and LOX turbopumps experienced rotordynamic whirl instabilities during the development of the SSME. When a system is rotordynamically unstable, the shaft can precess in either a forward or backward direction. An example of whirl instability is shown in Figure 20-1.

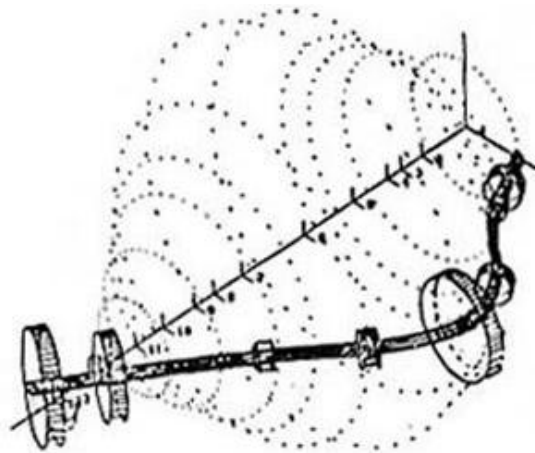

Figure 20-1. Turbopump Whirl

In this figure the shaft is rotating at some required speed, i.e., synchronous frequency, about its center line. Simultaneously precessional motion occurs, represented in this figure by the bent distorted shape. The rotational speed (frequency) of the bent distorted shape is the precessional speed and it is usually at a subsynchronous frequency. For a linear system, this frequency is one of the system natural frequencies. The ratio of the subsynchronous to the synchronous frequencies depends upon the cause of the instability. Rotordynamic instabilities have been caused by effects of internal rotor friction, annular journal bearings, turbine blade Alford forces, impeller-diffuser interactions, pulsating torque, axial-radial coupling, etc.

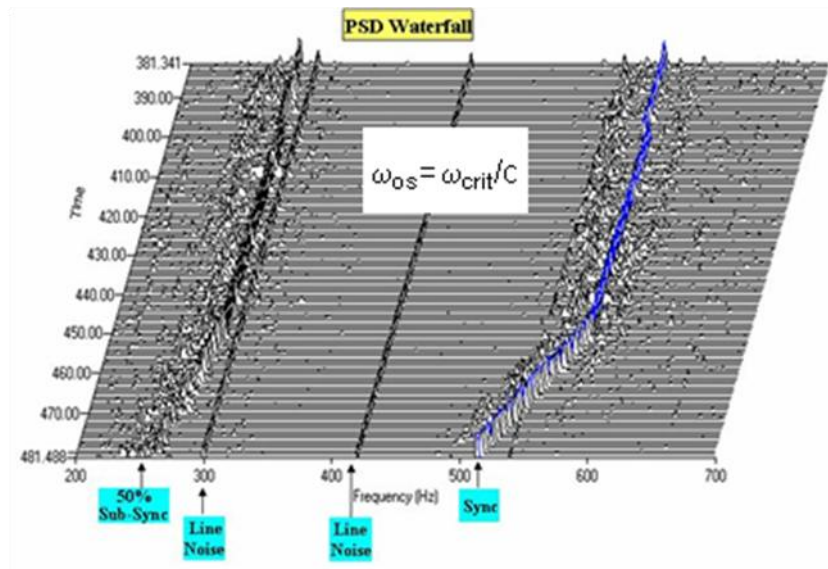

Figure 20-2. Acceleration Power Spectral Density (PSD) Isoplot

Shown in Figure 20-2 is an isoplot of the output of an accelerometer on a turbopump where there is rotordynamic instability. In this three dimensional plot the power spectral density (PSD) amplitude is the vertical axis and the axes in the plane represent time and frequency. If there were no instability, the acceleration response would be only the synchronous frequency as shown on the right side of the figure and in addition there would not be a significant amount of noise. However, when there is rotordynamic instability, in addition to the synchronous frequency there will be a subsynchronous frequency as shown on the left of the figure. As seen in Figure 20-2, the ratio of the subsynchronous frequency to the synchronous frequency is about 1/2. This is typical where instabilities are induced by effects associated with journal bearings, see reference [von Pragenau, 1982]. In journal bearings the flow between the rotor and stator is Couette flow and the Couette flow factor $C=1/2$ since the velocity profile is linear.

In the development of the SSME, the first incident of rotordynamic instability was in 1976. The instability was in the high pressure fuel turbopump. In this case the interstage seal was changed from a labyrinth seal to a step smooth seal along with stiffening the shaft and bearing carriers. The critical frequency went from about 9,500 rpm to 18,000 rpm. Thus the onset speed would be about 36,000 rpm.

The SSME LOX pump first experienced rotordynamic instability in 1982. A damping seal bearing was implemented on the pump end. LOX is supplied by the preburner pump impeller and discharges through the pump end bearings. As a consequence of the damping seal bearing, the instabilities were suppressed. In the region of the damping seal bearing, the stator was roughened and Couette flow no longer had a linear velocity profile. The Couette flow factor was reduced moving the onset speed out of the region of operation. Although George von Pragenau conceived the damping seal in the mid-1970's, it wasn't implemented until 1982. The damping seal bearing was a technical breakthrough that enabled

rotordynamic stability in both the LOX and fuel turbopumps. It moved the instability onset speed out of the operating range with significant margin.

In 1986 there was an attempt to operate the SSME at 109% power level. The speed of the fuel pump would be near or slightly exceed 36,000 rpm (potential onset speed). A production pump was built without a damping seal bearing with the thought that if there was instability a damping seal bearing could be added. In the initial test, the pump speed was 36,860 rpm and there was instability. The interstage step smooth seal was replaced with a damping seal bearing and instability was eliminated.

Whirl motion results in high static and dynamic loads that catastrophically impact the system through bearing wear and/or rubbing of the rotating assembly. This is unacceptable and will result in loss of hardware. Action must always be taken to eliminate whirl instabilities in rotating machinery.

SSME LOX Pump Spalled Bearings

Before the first flight of the Space Shuttle, there was spalling (pitting) of the pump end bearings in the SSME LOX pump. Shown in Figure 20-3 is the Rocketdyne LOX turbopump. The duplex bearings are shown on the pump end.

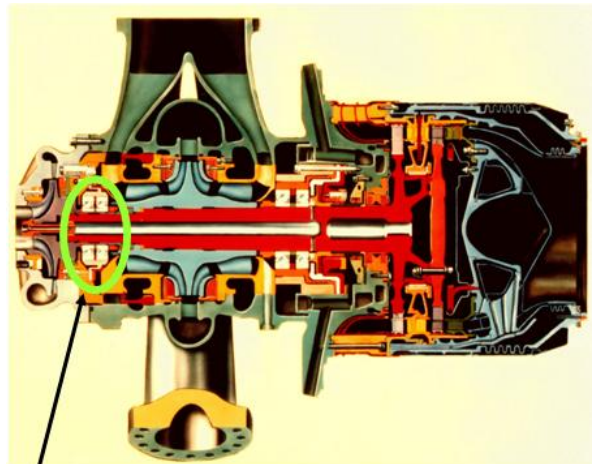

Pump End Bearings

Figure 20-3. Rocketdyne LOX Turbopump

The cause of spalling was unknown. In fact, it was not known if it occurred at startup, steady state running, or shutdown. In addition, there were no engine failures because of spalling during development testing.

It was not known if spalling was a failure mode. It was decided to put spalled bearings in several turbopumps and test them for 800 seconds. All the turbopumps had redline protection and it was thought that if there was an incident the redline protection would shut

the engine down before serious damage could occur. It turned out that the pumps were tested without an incident.

As a consequence of these tests, spalling would not be a flight issue and the first flight was successful. However, the bearings were replaced after every flight. In addition, turbine blades were replaced after every flight. The cost of these replacement activities was \$3 million per pump. The turbopumps that are being flown today have silicon nitride bearings and this is no longer a concern.

SSME Main Oxidizer Valve Buzz Solution

During development testing there were two major engine failures caused by acoustically induced vibrations in the vicinity of the main oxidizer valve (MOV). In addition, it was observed that about 20% of the engines had these vibrations without serious consequences. Initially it was determined that the high vibrations were coming from the MOV. This was perplexing since the MOV had no moving parts. Shown in Figure 20-4

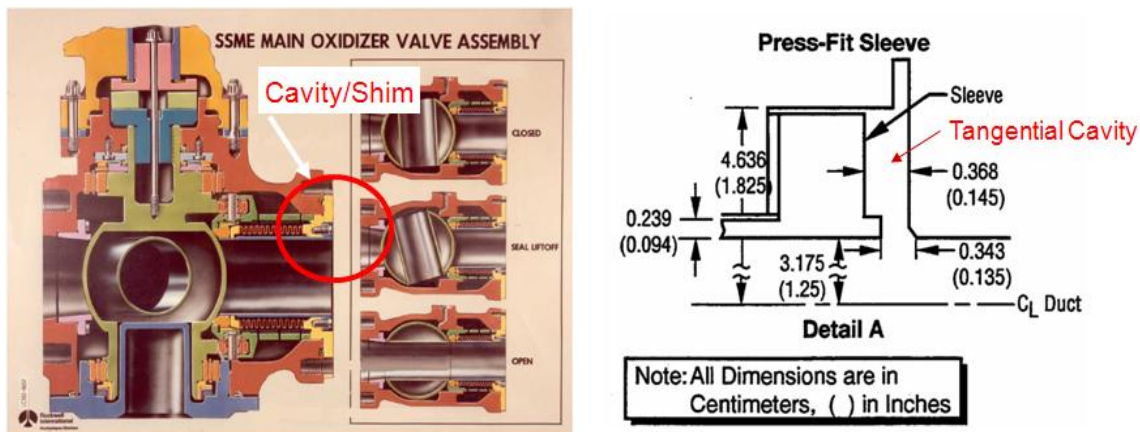

Figure 20-4. Main Oxidizer Valve

is a MOV pictorial cross-section on the left and on the right is a cross-sectional sketch of the cavity/shim region. In the valve there is a bellow spring and at the end of it is a Kel-F seal. The purpose of the spring and seal is to keep the MOV from leaking. Each MOV has to be individually adjusted to obtain the required sealing. In the figure on the right, it can be seen that the region in the vicinity of the tangential cavity a “gap” is formed that varies horizontally depending on the sealing adjustments. The LOX inlet flow to the MOV develops vortex shedding frequencies across the .343 inch gap thereby producing “edge tones” which are then tuned with the longitudinal acoustic duct mode and the tangential cavity acoustic mode. This tuning resulted in a “whistle” with an RMS pressure amplitude of about 165 psi and a fundamental frequency of about 7,300 Hz. These high pressure amplitudes vibrated the parts inside the valve until rubbing occurred causing a fire and significant hardware damage. A contributing factor to the high amplitude pressure oscillation was the 800 psi dynamic pressure in the LOX line (e.g. high power density).

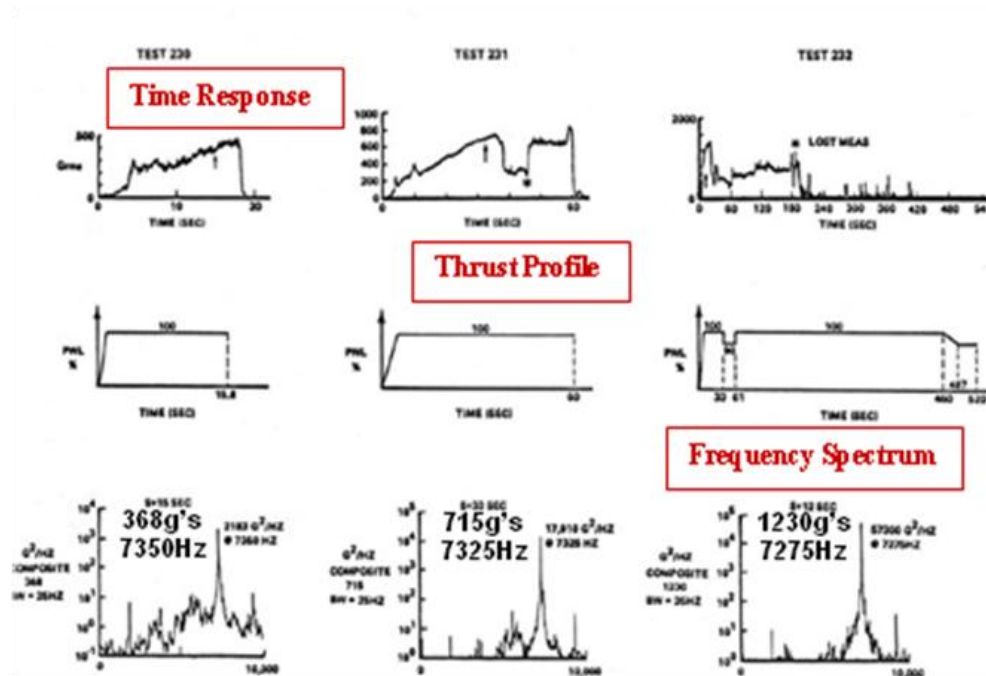

Figure 20-5. MOV Vibration Test-to-Test Response

Figure 20-5 shows data from a consecutive sequence of SSME tests. At the top are the MOV vibration responses, G_{rms} , as a function of time, in the middle are the thrust profiles as a function of time, and at the bottom are PSD's of the vibration for each test. Each of these tests were at the same power level, but as can be seen the vibration levels increased from test to test. At the bottom of Figure 20-5, it can be seen that the vibration levels went from 368 to 1230 g's.

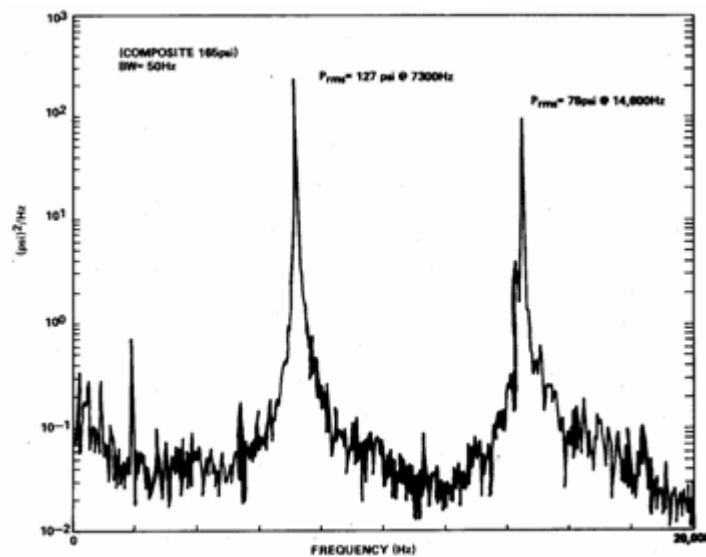

Figure 20-6. MOV Inlet Pressure Fluctuations

Shown on Figure 20-6 is a typical PSD of the pressure fluctuations at the inlet to the MOV. It can be seen that overall rms level is 165psi. At 7,300 Hz. the rms value is 127psi and at 14,600 Hz the rms value is 78 psi. These high fluctuating pressure levels are a consequence of frequency tuning of the vortex shedding, longitudinal acoustic duct mode, and tangential acoustic cavity mode. This tuning situation is compounded by the fact that the amplitude of the pressure fluctuations is proportional to the dynamic pressure and it is about 800 psi.

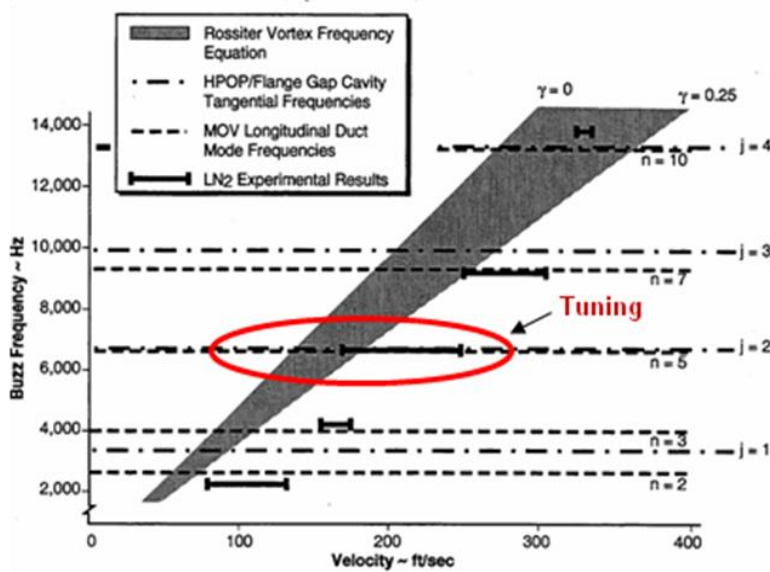

Figure 20-7. Acoustical Mechanism

Shown in Figure 20-7 is a Campbell diagram that illustrates and verifies the tuning mechanism. In the region where the tuning is indicated, it shows frequency results from LN₂ flow testing of the MOV, Rossiter's vortex shedding equation, longitudinal duct mode, and flange gap cavity tangential mode. All these frequencies coalesce resulting in tuning of high pressure fluctuations that caused the MOV high vibration levels, see reference [Schutzenhofer et. al., 1980].

The approach to eliminating these high acoustical pressure fluctuations was to put a shim in the flange gap cavity so as to "fill/close" the tangential cavity gap and prevent the vortex shedding/edge tones from being generated. Thus, the source was eliminated.

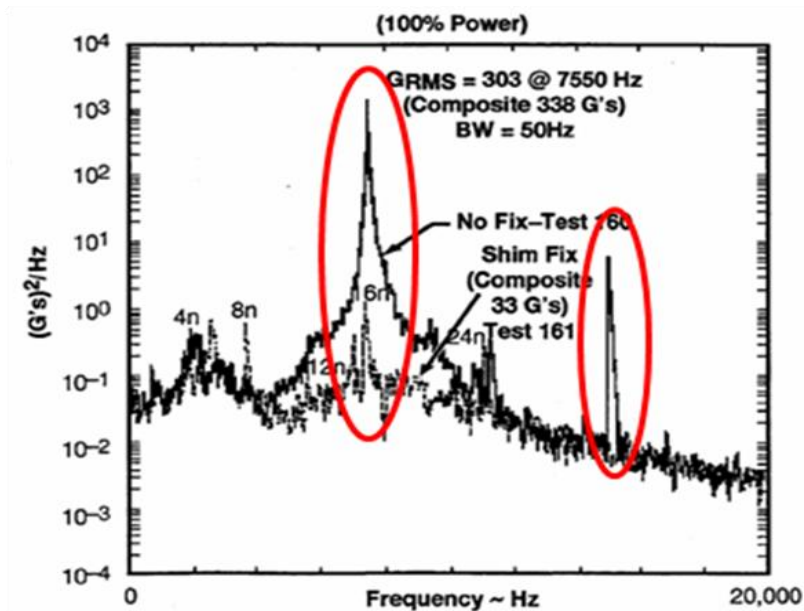

Figure 20-8. Effect of Fix

Shown in Figure 20-8 is a comparison of vibration responses of the MOV with and without the shim. It can be seen that the g-level went from 338 g's to 33 g's. Thus, the mechanism was verified along with the shim fix.

In rocket propulsion systems there are high power densities. This can be illustrated if a comparison is made between the dynamic pressures of a launch vehicle in flight and the dynamic pressure of flow (e.g. MOV) in a rocket engine. In the flight of a launch vehicle the maximum dynamic pressure is about 5 to 6 psi. This is important because all the point, distributed, and unsteady loads are proportional to the dynamic pressure. In the case of the MOV the dynamic pressure was 800 psi. Here too, all the steady and unsteady loads are proportional to the dynamic pressure. The consequence is: things that may usually be unimportant now become important. In this case, two SSME's were lost to an otherwise seemingly "benign whistle" that produced MOV vibration levels as high as 1230 g's; caused by tuning and high dynamic pressure. Eventually, the MOV problem was resolved by independent analyses and component tests.

✦ **A key message from Lesson 20 is:**

Our history tells us that critical areas require independent parallel analyses, test, and design activities; along with the creativity and innovation of analysts and designers.

Lesson 21: All Analyses and Tests are Limited

✦ All analyses and tests are limited. They are based on a set of assumptions. Don't extrapolate beyond the assumptions.

- ✦ **Analyses are limited: boundary and initial conditions, physical parameters, sub-models, numerical methods, etc.**
- ✦ **Analyses should precede tests**
- ✦ **Tests are limited: similarity parameters, boundary conditions, partial test models, lack of combined environments, instrumentation, data processing, etc.**
- ✦ **Benchmarking analyses and tests is required to extrapolate to flight conditions**
- ✦ **Determine sensitivities with respect to key variables**
- ✦ **Analysis and test results should have associated uncertainties identified**

All analyses and tests are limited. They are based on assumptions and models. Don't extrapolate beyond a validated set of analyses and tests.

The level of analyses has significantly advanced due to the speed and capacity of high performance computers. However there are limitations due to numerical methods, sub-models, definition of initial and boundary conditions, physical parameters, etc. Similarly, there are limitations in testing, for instance: lack of ability of achieving similarity, boundary conditions, partial modeling, lack of combined environments, etc. Even though these limitations exist, the designer has to use a combination of analyses and tests to achieve the best balanced design.

Initially, both the analyses and tests may be immature due to lack of definition of the design space. Analyses should always precede testing as a guide to test definition. After the test, the physics and design space will become clearer. Then the analytical modeling can be updated. This will lead to clarification of the design space and provide direction for additional testing. In complex situations there may be a series of iterations to both determine the design space and converge the modeling and testing, i.e. anchoring the model.

In some cases there may not be exact similarity because of an inability to achieve testing in exact dynamically similar conditions; for instance, high Reynolds number flows, chemically reacting flows, etc. In these cases, methods have to be developed to account for lack of similarity. Sensitivity analyses with respect to key variables can provide insights into these effects and how to account for them in design. The ultimate determination in some of these cases is through flight testing, e.g. rocket engine plume effects.

In both analyses and tests, uncertainty has to be determined. This can be achieved by comparisons to historical data bases, test, and expert opinion.

Examples:

- External Tank GH₂ Diffuser
- SSME Dynamic Environments / CFD

External Tank GH₂ Diffuser:

During the first test of the Space Shuttle Main Propulsion System (MPS), the GH₂ diffuser failed due to high cycle fatigue. Shown in Figure 21-1 is the MPS. The GH₂ diffuser is shown as the cylindrical object inside and at the top of the hydrogen tank. It promotes controlled mixing of hot incoming autogenous gas minimizing: ullage temperature, pressurant residuals, and gas impingement on the liquid surface during the start transient. The design goal is for the ullage gas to be like a piston pushing the liquid hydrogen out of the tank.

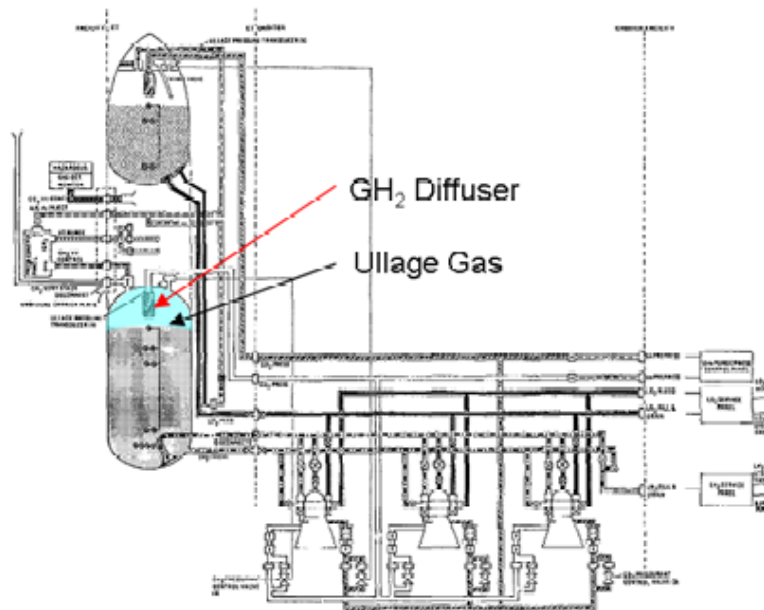

Figure 21-1. Space Shuttle MPS System

The design of the diffuser is based on the diffuser in the Saturn/Apollo S-IVB stage. The present configuration went through stress analysis and flow qualification testing. The results indicated that the diffuser had margin and was adequate for MPS testing.

However, the diffuser was sensitive to flow induced vibrations. After 26 hours of helium purging and 1.19 seconds of hot fire testing, the diffuser failed in the center of the cylinder with six pieces and portions of screen falling to the bottom of the LH₂ tank. Shown in Figure 21-2 is the failed diffuser.



Figure 21-2. GH₂ Diffuser

Initial analyses and testing indicated that the system was adequate. Subsequent to the MPS failure additional analyses and testing could not determine the failure cause. It was observed that a significant number of strain gages and accelerometers were on the test articles for the purpose of measuring response. This instrumentation dampened the response and all were removed except for three strain gages. In subsequent testing the response increased significantly and the diffuser failed in flow facility testing. Shown in Figure 21-3 (on the left) is the rms stress versus mass flow rate during helium flow tests. [Norquist, 1979] On the right side of the figure is the rms stress versus the number of cycles to failure. It can be seen that the rms stress is above the endurance limit of Aluminum 6061 and cyclic fatigue failure is imminent.

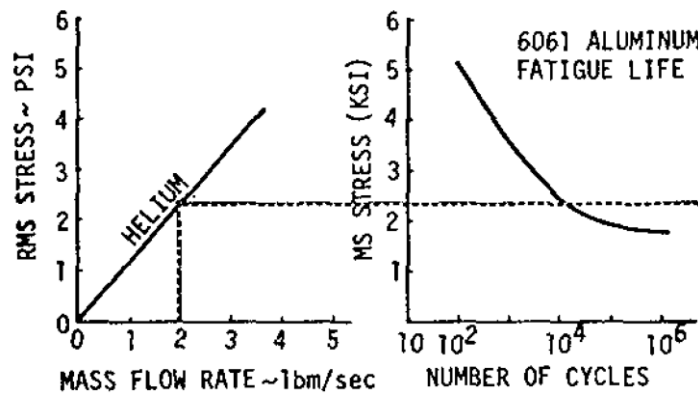

Figure 21-3. RMS Stress for Aluminum 6061 before Fix

The diffuser was redesigned and the .050 inch wall thickness of the aluminum was changed to a .085 inch wall thickness of 21-6-9 steel. In addition an inlet nozzle was used instead of a flat plate to reduce noise levels. The results of flow tests, shown in Figure 21-4, indicate that the redesigned diffuser's rms stress was below the endurance limit. In subsequent MPS testing the diffuser functioned adequately.

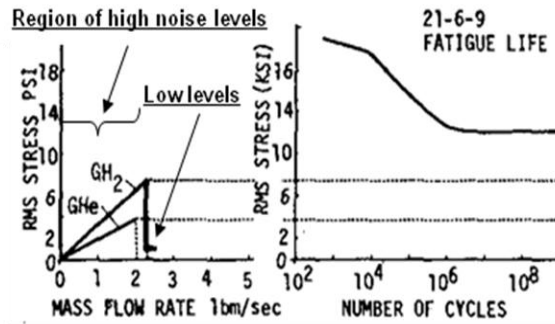

Figure 21-4. RMS Stress for Steel 21-6-9 after Fix

SSME Dynamic Environments / CFD

During development of the SSME there were numerous fatigue problems; many were the result of high static and dynamic environments driven by the high chamber pressure and exacerbated by tortuous flow paths with protuberances and cavities. Examples of failures include: LOX posts, main oxidizer valve, flow meter, splitters, high pressure fuel pump impeller, capacitor probe, etc.

Prediction capability in these extreme environments was limited to nonexistent. For example, flow analyses in the H-1, F-1, and J-2 engine programs were one and two dimensional and the chamber pressures were: $P_c =$ (H-1, 652psi; F-1, 982psi; and J-2, 763psi). In addition, these engines were expendable. In comparison to the SSME, its chamber pressure is 3100psi and the engines are reusable. The static and dynamic flow induced loads can increase by at least the ratio of the chamber pressures (e.g. factor of three from F-1 to SSME).

At the beginning of the SSME program the flow analyses were mostly one and two dimensional. However, it became clear that knowledge of the environments needed to be improved. Although computational fluid mechanics (CFD) had been tried over the years, its lack of maturity did not support design activities. However, improved computer capacity and speed, advanced numerical methods, and turbulence modeling could potentially enable application of CFD to design. In 1987 CFD was introduced into the design process with the goal of making it a design tool. To achieve that goal the following requirements were implemented: (1) Integrate/improve the capabilities of propulsion contractors, academia, CFD specialists, and government flow analysts; (2) Improve CFD methods/codes as required for design; (3) Benchmark CFD methods/codes for engine application; and (4) Implement results into design process.

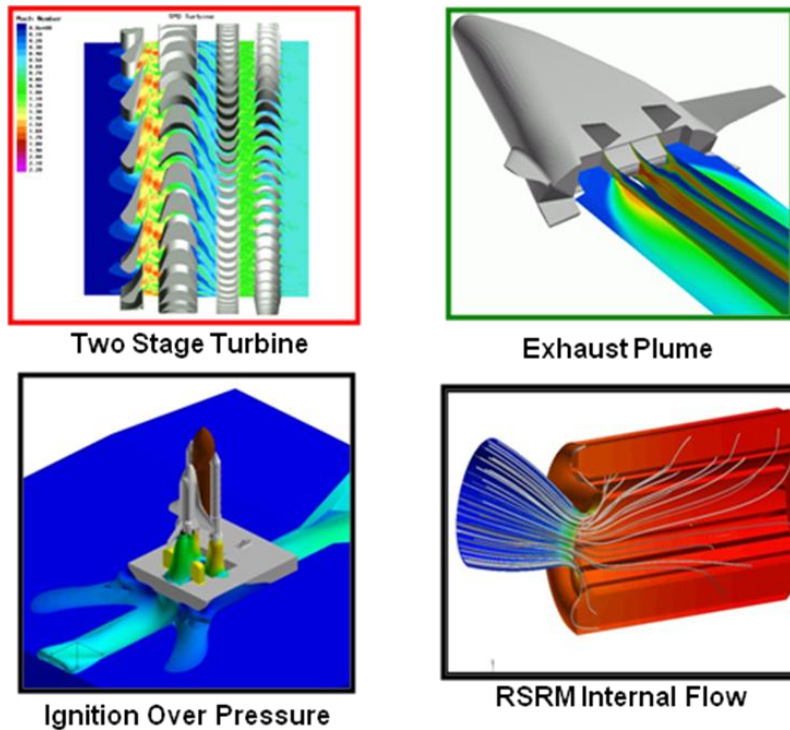

Figure 21-5. Examples of Computational Flow Dynamic Results

A consortium of CFD analysts and flow testing specialists was formed to focus activities on improving efficiencies of turbines, pumps, and combustion devices. Three respective teams were formed and about \$5-6 million/year was allocated for CFD and \$2-3 million/year for benchmark testing. Within a period of 4 years efficiencies in turbines and pumps were improved to the extent that the number of stages could be reduced. The cost savings for a program were \$70 million for the turbine and pump stages each.

Shown in Figure 21-5 are typical examples of CFD results. These activities support steady and unsteady flow loads, heat fluxes and thermal environments, and trajectory and performance analyses. CFD has evolved into a significant design tool and has improved the fidelity and reduced the uncertainty of new design.

While analyses and tests are critically important tools in design and development of high performance systems, the designer has to be aware of associated assumptions and limitations; including effects of uncertainty. If not thoroughly understood, misleading or incorrect results lead to very costly development problems, operational costs, and hardware redesigns. Check sensitivities; they provide indicators where there may be problem areas.

✦ **A key message from Lesson 21 is:**

***Be aware of the assumptions and limitations of your analysis/test model.
Don't eat the menu!***

Lesson 22: Scaling Is a Major Issue

- ✦ **Scaling is a major consideration.**
 - ✦ **Manufacturing process development**
 - ✦ **Scale model testing**
 - ✦ **Data analysis**
- ✦ ***Scaling is so commonly used that it sometimes is applied without critical examination.***
- ✦ **To preclude misleading results, question and understand scaling effects and the bounds of their applicability.**

Scaling is a major consideration in design, testing, and manufacturing. Scaling is used for many purposes, including:

- Relating smaller test articles to full-scale hardware.
- Relating and extrapolating test environments to flight environments.
- Developing manufacturing processes using test articles that are smaller and less expensive than full-scale hardware.
- Relating and extrapolating data bases derived from configurations different from the predicted flight configuration.

Because scaling is used so commonly and frequently, it is easy to become complacent in its application. However, as is the case for so many aspects of the design process, scaling must be carefully and judiciously applied so as to understand its effects and not exceed the bounds of its applicability.

Examples:

- X-33 Fuel Tank
- Saturn I Scale Model Dynamic Test

X-33 Fuel Tank

The X-33 Fuel Tank failure of Lesson 18 gives an example of a scaled manufacturing process that produced misleading results. The adhesive strength of the small-scale test panels was found to be adequate in test, but the size of the full-scale panels required a longer out-time for adhesive application before going to the autoclave. This longer out-time resulted in approximately 50% loss of adhesive strength in the full-scale hardware.

Saturn I Scale Model Dynamic Test

The Saturn I scale model dynamic test provides another example of unexpected scaling effects. It was planned to use a one-tenth scale model of the Saturn I for precursor dynamic tests. The small scale was chosen for expected economy and ease of testing. It was found that to obtain valid results, the tolerances and fasteners of elements had to be

proportionately scaled down. This entailed extreme accuracy of the test hardware, which was a challenge to produce. Only by using these scaled manufacturing tolerances could representative structural mode shapes and frequencies be obtained. [Grimes, 1970]

✦ **A key message from Lesson 22 is:**

Scaling is a major issue in design, testing, and manufacturing verification. To preclude misleading results, critically question and understand scaling effects, and apply validated scaling laws.

Principle VIII: Anticipating and Surfacing Problems Must be Encouraged

Many of the lessons cited in this report are derived from failures. What is needed is to find ways of precluding failures—to prevent them from happening. Three lessons on avoiding problems will be addressed:

- 23. Must Hear and Understand All Technical and Programmatic Opinions**
- 24. There Are No Small Changes!**
- 25. Expect the Unexpected**

Lesson 23: Must Hear and Understand All Technical and Programmatic Opinions

✦ **Minority opinions are necessary and provide insight.**

- ✦ **All our answers are incomplete, based on assumptions we select.**
- ✦ **Different assumptions and perspectives are needed to get a more complete picture.**
- ✦ **Our systems are very complex, highly interactive; therefore, we need all the insights we can get in order to ensure success.**

✦ **Apply Critical Thinking and avoid normalization of deviances.**

- ✦ **Think about how the real system will perform, and what could go wrong.**
- ✦ **Recognize and question model/test assumptions and deviations in data trends.**

As has been emphasized, space systems are exceedingly complex. Because of this complexity, our understanding of the systems is always limited and incomplete. Consequently, we must continually press to increase our understanding of the system and to

anticipate problems that may arise. Lesson 18 emphasized scrutinizing the hardware and its data in order to advance our understanding. Lesson 20 advocated independent analysis, test, and design as another component of understanding. This lesson addresses the importance of encouraging multiple viewpoints and opinions, for many perspectives are needed in the quest for the true composite picture of the system.

In many cases, minority opinions can be the most valuable, as they often come from people who have a creative or unconventional thought process that may provide a unique insight. While it is sometimes inconvenient or uncomfortable to deal with minority opinions, they should be encouraged. They are often the best examples of the critical thinking that is essential to product success.

Example:

Wernher von Braun – Saturn I Test

Consider the response of Wernher von Braun on a Saturn I dynamic test issue. The issue concerned data from the dynamic test for Saturn I which was used in control system design. One engineer, who was a creative individual, analyzed the data in an unconventional way, separating out the effects of the suspension system on the dynamic modes. Using these so-called corrected modes meant that the control system as designed would be unstable.

Two weeks were allocated to study the problem. Further study revealed that the new modes were not real, but were a result of an artifact in the numerical analysis. At the end of the two-week period, a presentation was made to Dr. von Braun, showing that the mode shapes were good as originally analyzed; therefore, the system was stable and safe to launch.

A laboratory director at the meeting complained that we had wasted two weeks “chasing rabbits”. Dr. von Braun’s response was, “What if he had been right? We always have time to get the right answer.”

Twenty-five years later, this creative engineer who had analyzed the Saturn I dynamic data invented the program-saving damping seal for turbomachinery. Did Dr. von Braun do the right thing in valuing and nurturing this kind of minority opinion and creativity?

✦ **A key message from Lesson 23 is:**

We must listen to all technical and programmatic opinions.

Listen

Listen

Listen!

Lesson 24: There are No Small Changes!

- ✚ **There are no small changes. All changes occur in a system and therefore affect the whole system.**

The familiar saying “There are no small changes” means that all changes occur within a system and therefore affect the whole system, often in unexpected ways. This principle is sometimes called the Law of Unintended Consequences.

Engineering history is replete with cases where this often-painful lesson has been experienced. We will cite four such examples.

Examples:

- Tethered Satellite Level Wind Bolt
- Saturn SI-C Pogo
- Saturn S-II Pogo
- External Tank Insulation Blowing Agent

Tethered Satellite Level Wind Bolt

The Tethered Satellite was intended to be deployed from the Shuttle Orbiter payload bay on a 22 km tether, to explore numerous promising technologies that tethered systems might enable. The tether was deployed and retrieved from a spool in the payload bay through a level wind mechanism similar to those found on some fishing reels (Figure 24-1).

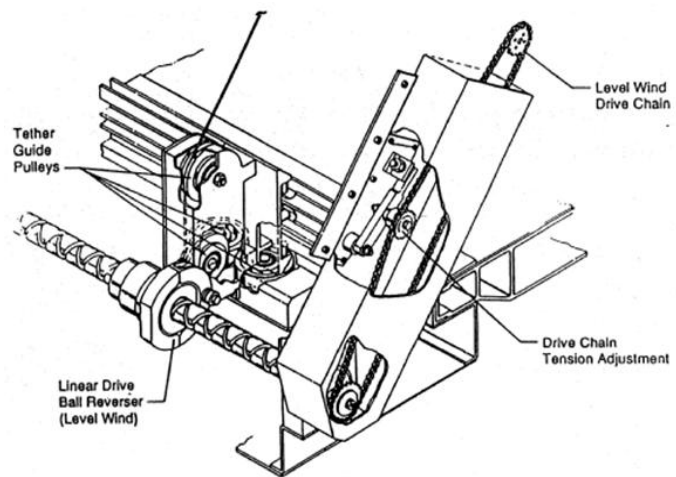

Level Wind Mechanism

Figure 24-1. Tethered Satellite and Level Wind Mechanism

As the first tether mission was approaching flight readiness, an analysis showed that a bolt on the level wind mechanism did not have sufficient strength for the predicted stress. A change order was prepared to change the bolt to one having stronger material. Since the hardware was already assembled, there was a concern that there might be some shifting of the parts when the bolt was removed, so in order to make sure the threads of the new bolt would engage, it was made longer as well as stronger.

Running a tether deployment test after the change would have caused a schedule impact, since the tether reel system was already in the payload assembly facility. So no system verification test was done after this “minor” change.

On orbit, the Tethered Satellite began its deployment without event, but when it reached 256 m, it stopped and would not progress farther. The longer bolt had jammed the level wind mechanism. While a few mission objectives were achieved by this short deployment, the main objectives were not. [Branscome, 1992]

The second Tethered Satellite mission attained 19.7 km of its planned 20.7 km deployment before the tether broke and the satellite was lost. Subsequent assessment attributed the failure to an arc from the conducting part of the tether to the deployer, severing the tether. The arc probably initiated through a pinhole in the tether insulation. This failure likely was not predictable, but could fall in the category of unknowns that the experiment uncovered. [Szalai, 1996]

While there have been some subsequent smaller tether experiments, failure of the two large Tethered Satellite System missions essentially resulted in this very promising technology being set aside, which is a significant loss. And it began with a change thought to be so small as to not require verification.

There should be system verification after any change. No change can be assumed to be “small”.

Saturn SI-C Pogo

Pogo is a vehicle longitudinal structural oscillation that is coupled with the Main Propulsion System and the liquid propulsion engines in a closed loop manner, which increases the oscillation and creates instability. It is named pogo after the classical children’s pogo stick. Figure 24-2 illustrates the analogy between the pogo stick on the left and a launch vehicle structural and MPS system combined to produce the closed loop instability.

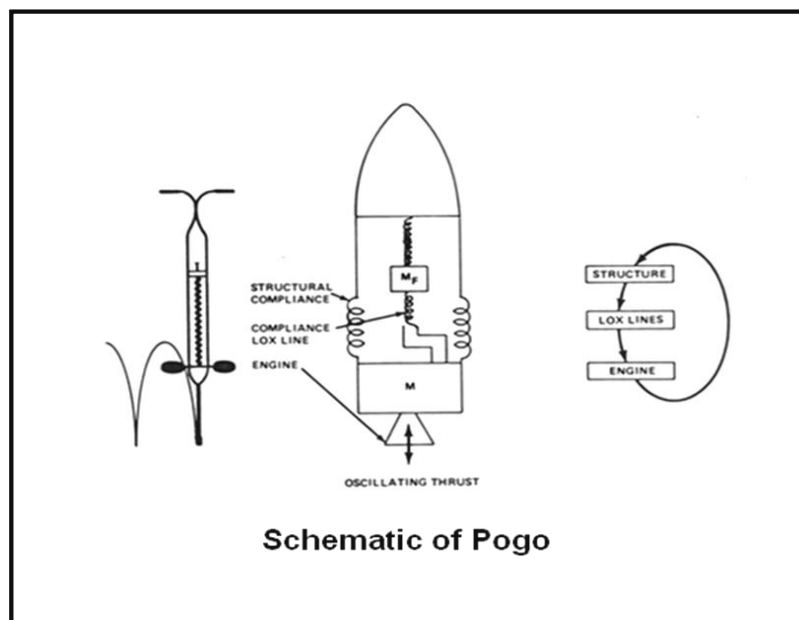

Figure 24-2. Pogo Oscillation Mechanism

Saturn V had two pogo instances. The first one occurred on the second Saturn flight AS-502 during first stage burn. The second occurred during second stage burn on the famed Apollo 13 mission. The first Saturn V vehicle AS 501 had no indication of pogo. Saturn AS-502 had a major incidence of pogo near the end of first stage (SI-C) burn. There were indications of pogo on the second stage (S-II) burn throughout the early program flights but were believed to be managed and under control; however, during the Apollo 13 flight, a near disaster occurred during the first 120 seconds of S-II stage burn. [Ryan, et al, 1969]; [Larsen, 2008]

The difference in the AS-501 and AS-502 vehicles was very minimal. The changes were small changes in the Apollo elements in order to better simulate their mass and dynamic characteristics. The changes were a shift in the mass of about 2,000 pounds in Service Module and Landing Module and 200 pounds added to the Launch Escape System (LEM) and 600 pounds added to the Command Module (CM). The mass change out of a liftoff mass of 6,000,000 pounds was a total of 900 pounds. This change on the front end of the vehicle increased the modal gain of the first longitudinal vibration mode about 30% and changed its frequency about 5%, causing it to couple with the LOX line mode. This caused the system to tune up and go unstable. Figure 24-3 shows the modal gain change, the frequency change and the coupling of the two modes near SI-C stage burnout.

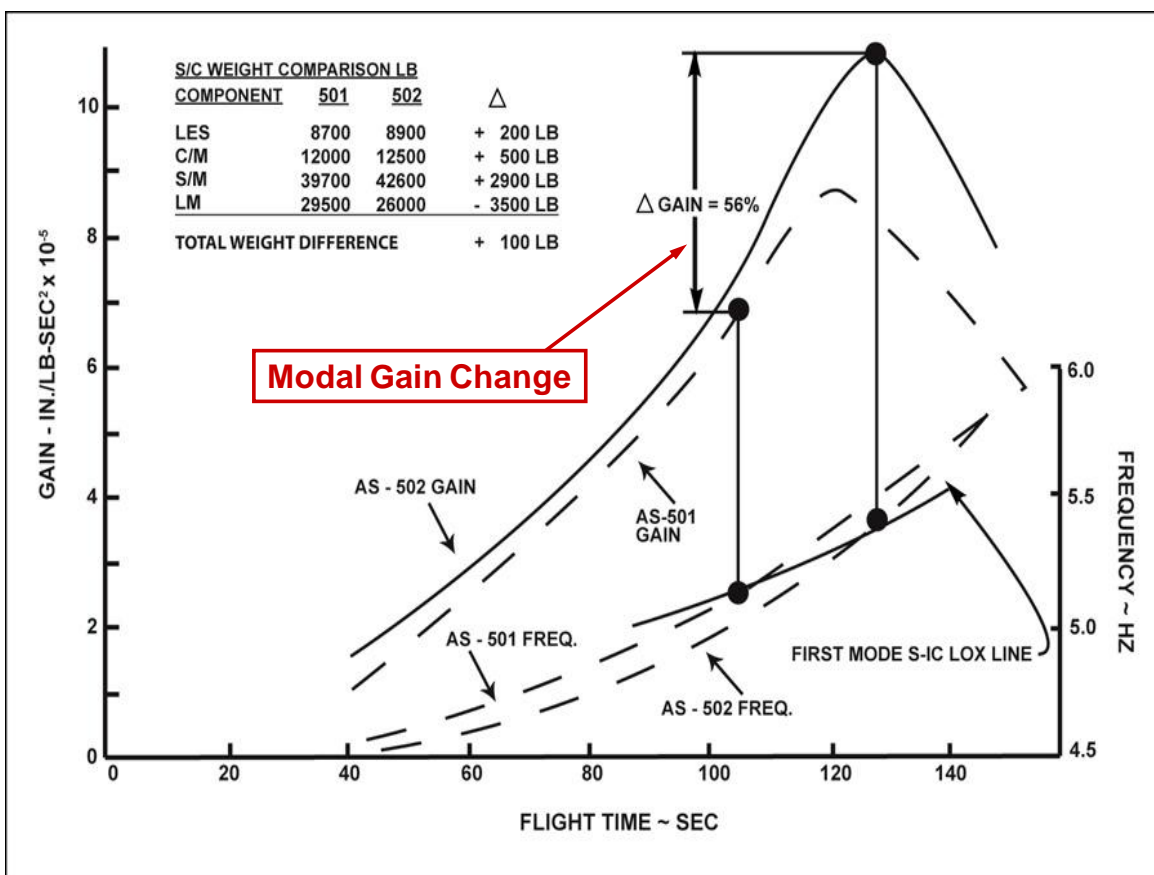

Figure 24-3. Comparison of SI-C Longitudinal Dynamic Characteristics

The fix was fairly simple and easily implemented, including a pogo accumulator around a prevalve (Figure 24-4). The accumulator detuned the LOX line from the first longitudinal line and the SI-C stage did not experience any pogo on the remaining flights. It truly is amazing that that such a small mass change on the front end of the vehicle that weighed 6 million pounds at liftoff could have such a large change on the dynamics of a vehicle the size of Saturn V. [Ryan, et. al., January 20-23, 1969]

Saturn V First Stage Pogo

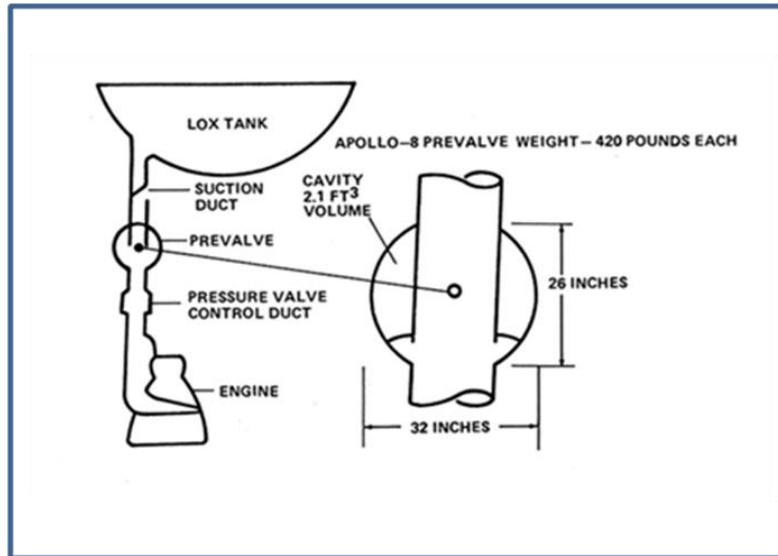

Figure 24-4. S-IC Pogo Accumulator

Saturn S-II Pogo

The S-II stage had shown on basically every flight some small coupled oscillations that were indicators of the pogo phenomenon. Most of these occurrences were a ballooning and decaying crossbeam acceleration at approximately a 12 Hz longitudinal mode, which was occurring during the whole burn of the S-II stage. They were of small amplitude except during the last 60 seconds of burn. There was a pogo working group that was composed of engineers from all the NASA centers, academia and industry who were working on the problem. It was decided that because the large amplitude was occurring the last 60 seconds of S-II burn, the center engine of the S-II stage would be shut down at that point and the other four engines burned longer so as not to have performance loss. Figure 24-5 is a composite of data from several S-II stage flights.

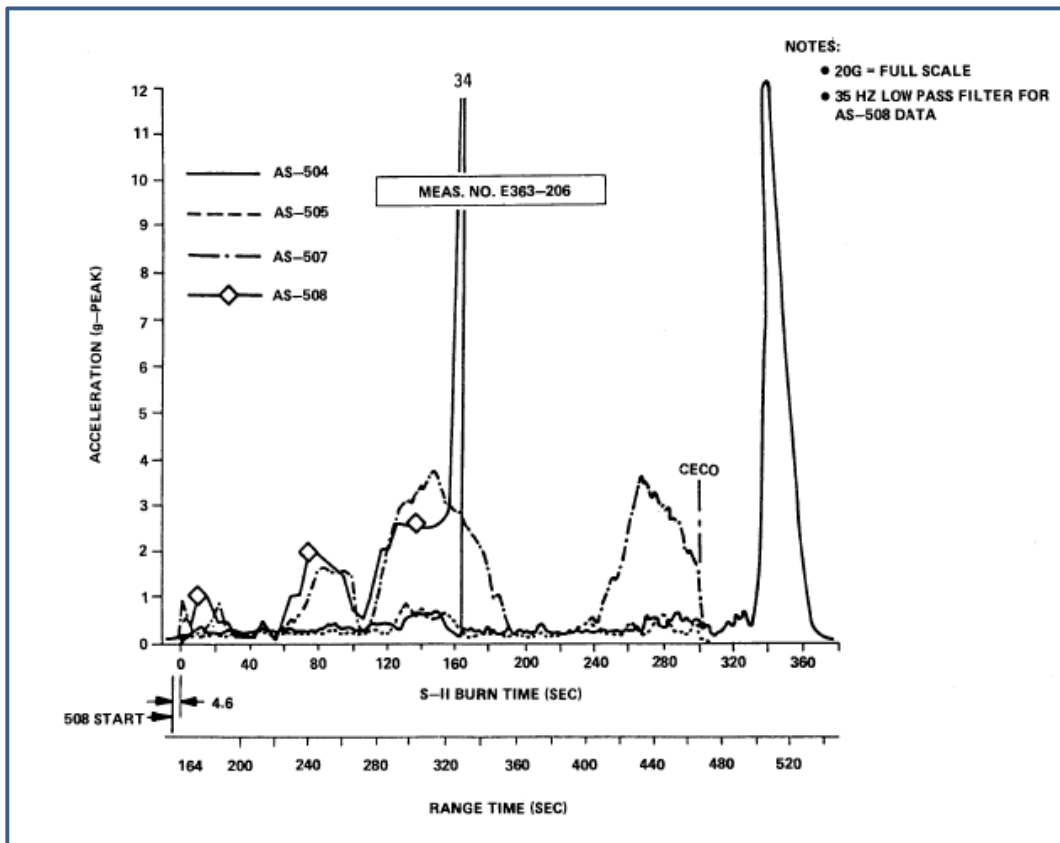

Figure 24-5. Pogo Occurrences on S-II Stage Burns

The center engine was the main contributor to the coupled oscillation as it had a strong coupling with the thrust frame participation in the longitudinal vehicle mode. In addition to the planned early shut down of the center engine, a “g” cutoff system was added to the gimbal area of the center engine as insurance to prevent vehicle failure. It was obvious that the engineering community did not fully understand the sensitivities and characteristics of this system, for on Apollo 13 around 120 seconds into S-II stage burn a large pogo oscillation occurred, shutting down the center engine due to excessive engine pump pressures. In reality the oscillation of the thrust frame/engine gimbal point reached 34 g’s and probably yielded the thrust frame. This oscillation is seen on Figure 24-5. The fix was putting a pogo accumulator at the end of the LOX line, detuning the system and solving the problem. [Ryan, et.al., December 1970]

External Tank Insulation Blowing Agent

The Shuttle External Tank (ET) is insulated on the outside skin by blowing insulation onto the tank as it rotates within a fixture. Blowing agents used in the past do not meet current EPA requirements, necessitating a change to an environmentally-friendly blowing agent. Any change like this, and in particular one that influences such a large area must be recertified. It is standard practice to verify these kinds of systems by testing at the corners of

the environments boxes. In this case the environmental variables were pressure, temperature and flow conditions. When the tests were completed no difference in the response of the insulation was noted and the system was flown. Cameras were installed to see what would happen in flight and the insulation on the intertank was caught in a massive pop-corning of the insulation as the high temperature and low pressure condition were experienced. The old insulation had not shown this effect. The problem was worked extensively by a special team and in that process someone said that maybe the test should be run at nominal conditions and not in the corners of the environment combinations. When this was done the insulation pop-corned as it did in flight. It was found that when testing at the corners of the combined environments box that the extreme environments were venting the trapped blowing agent gases and there was no pop-corning but that when you tested at nominal environments the only way the insulation could vent the trapped blowing gas was to blow off small pieces of insulation. The message is twofold in that (1) no change is small, and (2) certification must be performed at all environmental combination levels. The fix was to punch small holes in the insulation after it was blown on so that it would have vent capability. Since that fix has been implemented there is been very little pop-corning of interstage insulation. Figure 24-6 shows a flight photo where half of the area had the small holes punched and had no pop-corning, whereas the other half without the fix did show pop-corning.

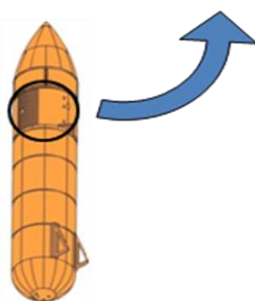
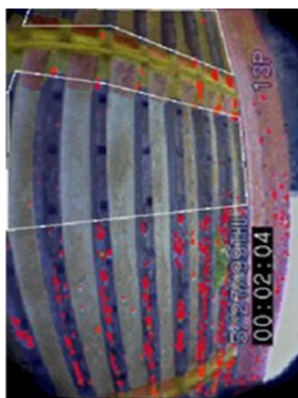

Figure 24-6. ET Intertank Insulation With and Without Pop-corning Fix

✦ **A key message from Lesson 24 is:**

***Don't make unnecessary changes.
- Better can be the enemy of good***

- *Be very careful if a change is required*
- *Understand system interactions*

Verify the system with changes before flying.

Lesson 25: Expect the Unexpected

- ✦ **Expect the unexpected -- Things are never exactly what they seem.**

Ambiguity is ever present in aerospace systems. Many things are basically unpredictable due to the immense complexity of the systems and many unexpected things happen. The unexpected events take many forms, from human, to nature, to the physics of the system we are dealing with. The nature of design and operations of space systems means that we must constantly be on the watch for signs and characteristics of these unexpected events.

Example:

Woodpeckers on the ET Ogive

Only one example is used to illustrate these occurrences - the presence of a woodpecker pecking holes in the LOX tank ogive insulation while the vehicle is sitting on the launch pad (Figure 25-1). The vehicle had to be moved back to the VAB to repair the holes, and means of keeping woodpeckers away were implemented. "Evil-eye" balloon scarecrows and owl decoys were placed near the launch pad.

Woodpeckers on the ET ogive



Resulting holes



Countermeasures: Evil Eye balloons and owls

At the launch pad before STS-70, woodpeckers dug about 6 dozen holes in the ET insulation. The vehicle had to be rolled back to the VAB for repairs.

Figure 25-1. Woodpeckers on the ET Ogive

Expect the Unexpected!

- ✦ A key message from Lesson 25 is:

Design and operations of space systems require that you constantly must deal with ambiguity and the unexpected. This requires a constant focus on looking for the ambiguities and the unexpected.

Principle IX: Leadership is the Foundation

We started this report with the principle of the primacy of people. We are returning to this basic area with the principle that “Leadership is Foundational”. In any engineering organization two key tasks to success are management and leadership. Both are necessary and important; however, leadership creates the vision that sets the sails of the organization. Without leadership any organization will eventually fail since there is no clear path of where it is going. There are several aspects of leadership but only two will be discussed: *integrity*, and *focus beyond yourself*.

26. Integrity

27. Focus beyond yourself

Lesson 26: Integrity

- ✦ ***Sing your own "Music"***
- ✦ ***Integrity is matching what you do and how you do it with what's inside you.***
"Your Calling"

There are many facets or dimensions to integrity that are important to leadership. One that is pivotal is the match of what you are inside with what you say and do. It is of major importance that you are doing what is you, what is your way? Until you are working your inner calling the outward and inner are disconnected. The song “I Did It My Way” conveys some of what is meant here. Until what you are inside is what you are outside, leadership will have problems of trust by the organization. There are many examples of the application of this principle. George McDonough used to say about engineer’s writings, “As long as they are technically correct and get the message across, don’t get hung up on the style.”

Example:

Floyd Briscoe: “You must coach it your way. You can’t coach my way.”

When Robert Ryan was coaching basketball in his second year as coach he got as a principal a former successful coach. The principal told him, “Coach, I will come to your

practices and help ‘you’ train the team.” After one week of trying to help in the gym, he called Robert into his office and said, “Coach, it won’t work having me in the gym to help. You have a different style and the boys can’t learn two styles. They need one leader and one system. I will stay in the office and we can have discussions where I can pass on to you what I know. I will try to adapt what I know to your system. You must coach it your way, not mine.” Did his approach work? Yes, in Robert’s second year of working with him the team won the Alabama Class “A” 8th District and State basketball tournaments. The next year the team won the Alabama Class “A” 8th District and 2nd place State basketball championships. The other aspects of integrity are very important as well. If leadership is to be successful then all the aspects of integrity must be engaged.

✦ **A key message from Lesson 26 is:**

Without integrity, what you do and say is meaningless.

Lesson 27: Focus Beyond Yourself

✦ **You must focus beyond yourself, beyond the immediate. It’s Being versus Having.**

The tendency of individuals in an organization is to focus on their own interests and work areas and ignore other considerations. Everything we do in organizations is a system and what each individual does affects the total system. Because of these interactions it is imperative that we focus beyond ourselves and not build silos around our work and our self. One principle Bob Ryan learned from a professor at Vanderbilt-Peabody University was stated in the following way. “Each has a choice between focusing their life on *having* or *being*. The *having* focus is social in nature emphasizing what one can get, whether it be recognition, money or position. *Being* is spiritual in nature and focuses on what one can become. It deals with what you are and how you contribute meaning to the organization, the individuals and society.” This requires that we not only perform our tasks in an excellent manner, but also focus on the whole. As Stephen Covey says in his book, *The Eighth Habit*, “Find your own voice, help others find their voice.”

Example:

Building Silos

Eighty percent of problems occur due to a breakdown in the system, not in the individual discipline. However, we sometimes get so wrapped up in our discipline work that we fail to see the whole picture. Even worse, we often build protective “silos” around our turf. We must focus on the whole system so that we can see the interactions.

✦ A key message from Lesson 27 is:

“Everything acts as a system; nothing acts independently. It is a whole where all the parts interact, many times in unexpected and unpredicted ways.” -- Jim, Bob, Luke

“Systems engineering is one engineer” -- Max Faget

SUMMARY

This completes a study of *Lessons Learned in Engineering*. The lessons derived from the authors' experience have been distilled into principles that should be applicable across all technical areas. The principles and lessons are only important if applied. The key issue we face is the application of these principles and lessons to engineering organizations as well as their products.

A related question asked by the Directors of Engineering at MSFC was: “How do we achieve excellence in engineering?” The authors' approach to answering this broader question was a short course on Excellence in Engineering which is documented in a future NASA CR titled *Excellence in Engineering*.

We started this report with a set of nine generic principles based on 27 lessons derived from our experiences in space flight systems. These principles and corollaries are repeated below.

Lessons Learned Principles

- I. System success depends on the creativity, judgment, and decision-making skills of the people**
 - People are our most important resource
- II. Space systems are challenging, high performance systems**
 - High energy, high power density
 - Therefore, high sensitivity
- III. Everything acts as a system (whole)**
 - We design by compartmentalization and reintegration
 - Understanding interfaces and interactions is crucial
 - Requires pervasive communications
- IV. The system is governed by the laws of physics**
 - Reality can't be ignored
 - Look to the real performance of the hardware and software

-

- V. Robust design is based on our understanding of sensitivities, uncertainties, and margins**
 - Must consider sensitivities, uncertainties, margins, risks
 - Aim for robustness
- VI. Project success is determined by life cycle considerations**
 - Program constraints can result in a non-optimal design
 - Requirements can drive the design in unexpected ways
 - Early phases of project most influential on design
 - Design must consider full life cycle including manufacturing, verification, and operations
- VII. Testing and verification have an essential role in development**
 - We understand by testing
 - Must know limitations
- VIII. Anticipating and surfacing problems must be encouraged**
 - Critical thinking
 - Think out of the box
 - Listen
- IX. Leadership is the foundation**
 - Integrity
 - Outward focused
 - People centered

REFERENCES

- Alexander, R. and Beech, G., "Mass Properties Margins and Reserves Recommendations to SLI 2nd Generation Program," 7/10/2002. Presentation and Personal Communication with the Authors.
- Allen, L. "The Hubble Space Telescope Optical Systems Failure Report," NASA-TM-103443, November 1990.
- America's Best Gets Better, May, 2002:
<http://spaceflight1.nasa.gov/shuttle/seconddecade> .
- Ames Research Center, June, 2002:
http://www.nasa.gov/centers/ames/pdf/153087main_fs_shuttle_nas.pdf .
- AOMC Monograph "History of the Jupiter Missile System," Chapter V.
<http://www.redstone.army.mil/history/systems/jupiter/chapter5.html> .
- Augustine, N.R.: "Augustine's Laws," AIAA, New York, NY, 1983.
- Bauer, H., Fluid Oscillations In The Containers Of A Space Vehicle And Their Influence Upon Stability. TR-187, 1964.
- Benfield, P.A., Personal communication, 2010.
- Blair, J.C., Ryan R.S., Schutzenhofer L.A., Humphries W.R."Launch Vehicle Design Process: Characterization, Technical Integration, and Lessons Learned," NASA/TP-2001-0210992, 2001.
- Blair, J.C., and Ryan, R.S., "The Role of Criteria in Design in Management of Space Systems," AIAA-92-1585, March 1992.
- Boeree, C. G., 2006:
<http://webspace.ship.edu/cgboer/maslow.html> .
- Bookout, Paul S. and Tinker, Michael L., "International Space Station Payload Rack Frequency Sensitivity Assessment", AIAA-1996-1589, AIAA/ASME/ASCE/AHS/ASC 37th Structures, Structural Dynamics and Materials Conference and Exhibit, Salt Lake City, UT, Apr. 15-17, 1996.
- Branscome D., R. (Chairman), "Tethered Satellite System Contingency Investigation Board Final Report," NASA-TM-108704, August 1992.
- Brinkley, J. F., et. al., "From Data Collection to Lessons Learned Failure Information Exploitation at Aerospace Corporation," ISHEM 2005 Papers, November, 2005.

Buckingham, Marcus, and Clifton, Donald O., "Now, Discover Your Strengths," The Free Press, New York, 2001.

Chapman, W. L., Van Voorhees, F. D., Bahill, A.T., and Moody, J. A., "Metrics and Case Studies for Evaluating Engineering Designs," Prentice-Hall International Series in Industrial and Systems Engineering, 1997.

Chaffe, N., Complier, NASA Conference Publication 2342, Parts 1 and 2, "Space Shuttle Technical Conference" Lyndon B. Johnson Space Center JSC, Houston, Texas, June 28-30, 1983.

Chase, C. A. and North, D. A., "IUS Propulsion Status", AIAA/ASME/SAE 20th Joint Propulsion Conference, June 1984.

Cikanek, H.A., "Characteristics of Space Shuttle Main Engine Failures," AIAA-87-1939, AIAA/SAE/ASME/ASEE 23rd Joint Propulsion Conference, San Diego, CA, July 1987.

Clausing, Don and Andrade, Ron, Editors, "Creating Innovative Products Using Total Design" Addison-Wesley Publishing Company, New York NY, 1996.

Clayton, C., http://www.chuckclayton.com/articles/Critical_thinking_definition.htm.

Clemens, P. L., Pfitzer, T., Simmons, R. J., Dwyer, S., Frost, J., Olson, E., "The RAC Matrix: A Universal Tool or a Toolkit," Journal of System Safety, Vol. 41, No. 2, Mar.-Apr. 2005.

Collins, Jim, "Good to Great: Why Some Companies Make the Leap...and Some Don't," HarperCollins Publishers, New York, 2001.

Covey, Stephen R., "Principle-Centered Leadership," Simon & Schuster, New York, NY, 1992.

Covey, Stephen, Merrill, A. Roger, Merrill, Rebecca R., "First Things First: To Live, to Love, to Learn, to Leave a Legacy," New York: Simon and Schuster, 1994.

Covey, Stephen R., "The Eighth Habit; From Effectiveness to Greatness," Free Press, 2004.

David, L., NASA Shuts Down X-33 and X-34, March 1, 2001.:
http://www.space.com/missionlaunches/missions/x33_cancel_010301.html.
http://www.space.com/business/technology/x33_newlease_001002.html .

Dunn, W. P., "Evolution of the Inertial Upper Stage", Aerospace Org. Publication, Crosslink, Launch Vehicles, Vol. 4, Number 1, Winter, 2003.
<http://www.aero.org/publications/crosslink/winter2003/08.html> .

Eddy, Bill, "A Little Nonsense Now and Then", Meredith Publishing Co., Des Moines, IA, 1956.

Eddy, Bill, "Back to the Drawing Board Again", Graphic Arts, Inc., Philadelphia, PA, 1962.

Emero, D.H. "Quarter-Scale Space Shuttle Design, Fabrication, and Test," AIAA 79-0827, AIAA/ASME/ASCE/AHS 20th Structures, Structural Dynamics, and Materials Conference, 1979.

Ferguson, E.S.: "Engineering and the Mind's Eye." MIT, Boston, MA, 1992.

Gehman, H. W. (Chairman) et.al., "Columbia Accident Investigation Board", August, 2003:
http://caib.nasa.gov/news/report/pdf/vol1/full/caib_report_volume1.pdf .

Gibson, H., Thom, R., Moore, C., and Haluck, D. "Space Shuttle Main Engine Turbopump Bearing Testing at the Marshall Space Flight Center," Jannaf-1354.

Goble, Frank, "The Third Force," Pocket Books, New York, NY, 1971.

Gordon, J.E., "Structures, or Why Things Don't Fall Down, and Materials; Why Things Don't Fall Through the Floor," Decapo Press, 1986.

Gordon, J.E., "The New Science of Strong Materials," Princeton University Press, Princeton, NJ, 1988.

Griffin, M., March, 19, 2006:
<http://www.guardian.co.uk/science/2006/jun/19/spaceexploration.usnews>.

Greenleaf, Robert K.: "Servant Leadership, A Journey Into the Nature of Legitimate Power and Greatness", Paulist Press, Mahwah, NJ, 1977.

Grimes, P. J., McTigue, L. D., Riley, G. F., and Tildelt, D. I., "Advancements in Structural Dynamics Technology Resulting From Saturn V Programs," Volume I&II, NASA CR 1539 & 1540, National Aeronautics And Space Administration Washington, D. C. June 1970 St. Louis, Mo., April 4-6, 1979.

Guns, Bob, "The Faster Learning Organization," Jossey-Bass Inc., San Francisco, CA, 1996.

Havskjold, Glen, "The Product Development Imperative: Business Case for the Robust Design Computational System (RDCS) and the Acceleration Insertation of Materials (AIM) Technologies," Presented at ODU-NASA Training Workshop on Innovative Design of Complex Engineering Systems, March 23-24, 2004.

Havskjold, G., "Developing Innovative Products on Budget and On Schedule -- Part 1: Identifying and Measuring Cost Drivers Correlates Technical Uncertainty With Rework Cycles," AIAA-2009-5436, August 2009.

Havskjold, G., "Developing Innovative Products on Budget and On Schedule -- Part 2: Using Protocol Charts to Control Development of an Innovative Advanced Technology System," AIAA-2009-5437, August 2009.

Havskjold, G., "Developing Innovative Products on Budget and On Schedule -- Part 3: Generating the Protocol Diagram," AIAA-2009-5438, August 2009.

Holloway, T. W., Manager, Space Shuttle Program, "Shuttle System Design Criteria, Vol. 1, Shuttle Performance Assessment Databook", Revision B, March 16, 1999.

http://pbma.nasa.gov/docs/public/pbma/bestpractices/bp_jsc_49a.pdf.

http://pbma.nasa.gov/docs/public/pbma/bestpractices/bp_jsc_49b.pdf.

http://pbma.nasa.gov/docs/public/pbma/bestpractices/bp_jsc_49c.pdf.

http://pbma.nasa.gov/docs/public/pbma/bestpractices/bp_jsc_49d.pdf.

Holman, Special Document without publication information, by McDonnell Douglas Corporation.

Hopson, G.D, (Chairman), "Investigation Board Report SSME Serial Number 2004 Main Combustion Chamber Failure", Test Stand A-2 National Space Technology Laboratories, Part I, August 22, 1980.

Hopson, G.D, (Chairman), "Investigation Board Report SSME Serial Number 2108 Main Injector Failure," Test Stand A-1 National Space Technology Laboratories, Part I and Part II, July 15, 1981.

Hopson, G.D, (Chairman), "Investigation Board Report SSME Serial Number 0110 Main Injector Failure," Test Stand A-3 Santa Susana Field Laboratory, Part I and Part II, September 2, 1981.

Huitt, W., "Maslow's Hierarchy of Needs, Educational Psychology Interactive," Valdosta, GA. <http://www.edpsycinteractive.org/topics/regsys/maslow.html>, 2004.

Humphries, R., Wegrich, R., Pierce, E., and Patterson, W., "A Survey of Spacecraft Thermal Design Solutions," October 1991; ESA and AST, Fourth European Symposium on Space Environmental Control Systems, Florence, Italy, October, 1991.

Jenkins, D.R., "Space Shuttle—The History of Developing the National Space Transportation System," Walsworth Publishing, Marceline, MO, 1997.

Jewell, R.; Ryan, R.S., Bugg, F., Ivey, W., McComas, R., Kiefling, L.; and Jones, J.: "Dynamic Testing of Large Space Systems," NASA TM-78307, September 1980.

Jones, Jess H., Guest, Stanley H., Nesman, Tomas E., Matienzo, Jose' J., Reed, Darren K., "Acoustic, Overpressure and Unsteady Flow Phenomena Associated With Saturn/Space Shuttle Systems: A Review of Selected Issues," Presented at the International Conference on "Acoustic and Dynamic Environment of Space Transportation Systems", CNES/ONERA, Jouy-En-Josas, France, 8-11 February 1994.

Jue, F.H., "Space Shuttle Main Engine – Thirty Years of Innovation," AIAA 97-2819, June 1997.
<http://www.pwengineering.com/dataresources/SpaceShuttleMainEngineThirtyYearsOfInnovation.doc> .

Junkins, John, Personal communication.

Larsen, C. E., "NASA Experience with Pogo in Human Spaceflight Vehicles," Johnson Space Center United States of America, TX 77058 and RTO-MP-AVT-152, May, 2008.

Larson, W., J., et. al., "Space Launch and Transportation Systems," Vol.,1&2, July 2005, Distribution Authorized by the Department of Defense.

Livingston, J. Sterling, "Pygmalion in Management" *Harvard Business Review* September/October, 1988.

Lovingood, J.A., "A Technique for Including the Effects of Vehicle Parameter Variations in Wind Response Studies," NASA TM X-53042, May 1964.

Lundin, B. T. (Chairman), "NASA Investigation Board Report on the Initial Flight Anomalies of Skylab 1 on May 14, 1973," July 13, 1973.
http://klabs.org/richcontent/Reports/Failure_Reports/Skylab/Skylab_Report.htm.

Maslow, A. (1943), "A Theory of Human Motivation," *Psychological Review*, 50, 370-396.

Maslow, A. (1954), "Motivation and Personality," New York: Harper.

Maslow, A. (1971), "The Farther Reaches of Human Nature," New York: The Viking Press.

Maslow, A., & Lowery, R. (Ed.). (1998), "Toward a Psychology of Being" (3rd ed.), New York.

McComas, Bob, "ET LOX Modal Survey Analysis and Test Assessment", NASA TM-78287, May 1980.

McCool, A. A., and Ray, W. L., "Space Shuttle Solid Rocket Motor Program - Lessons Learned", AIAA-1991-2291, SAE, ASME, and ASEE, 27th Joint Propulsion Conference, Sacramento, CA, June 24-26, 1991.

Moody, J.A., Chapman, W.L., Van Voorhees, F.D., and Bahill, A.T., "Metrics and Case Studies for Evaluating Engineering Designs," Prentice Hall, 1997.

Mulloy, L., B., Crockett, C. D., Kross, D., A., and Miller C., D., "A Structural Assessment of the Space Shuttle Main Engine," NASA Report, May 1, 1980.

NASA Conference Publication 2342, Parts 1 and 2, Space Shuttle Technical Conference, "Challenge to Achievement", Norman Chaffe (Compiler), Lyndon B. Johnson Space Center JSC, June 28-30, 1983

NASA SP-106, "The Dynamic Behavior of Liquids in Moving Containers," H. N. Abramson, 1967.

NASA SP-4206, "Stages to Saturn: A Technical History of the Apollo/Saturn Launch Vehicles," Bilstein, R. E., 1980.

NASA SP-4221, Heppenheimer, L. A., "The Space Shuttle Decision," 1999.

NASA SP-8031, "Slosh Suppression - NASA Space Vehicle Design Criteria (Structures)," May 1969.

Nevins, C. D., "Designing for Solid Rocket Booster Reusability", AIAA-1975-1173, American Institute of Aeronautics and Astronautics and Society of Automotive Engineers, 11th Propulsion Conference, Anaheim, CA, Sept 29-Oct 1, 1975.

Nightingale, Earl; "Creative Thinking" #1 thru 3" Nightingale-Conant Corporation, Santa Barbara, CA., 1977.

Noor, A.K.; and Venneri, S.L.: "New and Projected Aeronautical and Space Systems, Design Concepts and Loads," ASME, New York, 1994.

Norbraten, G. L., "Day-of-Launch I-load Updates for the Space Shuttle", AIAA-1992-1274, Space Programs and Technologies Conference, Huntsville, AL, March 24-27, 1992.

Norquist, L., W., S., "Preflight Status of the External Tank Portion of the Space Shuttle Main Propulsion System," AIAA/SAE/ASME 15th Joint Propulsion conference, Paper 79-1143, June 18-20, 1979.

NYPD Compstat, Personal communication with New York Police Department.

O'Connor, G. M. and Jones, J., "Flow-Induced Vibrations of the SSME LOX Inlet Tee Vanes," AIAA/ASME/SAE/ASEE 24th Joint Propulsion Conference, AIAA-88-3132, July 11-13 1988.

Pack, H., Jr., and Young, L.E., "Solar Array Flight, Dynamic Augmentation Experiment," NASA TP 2690, NASA, Washington, DC, February 1987.

Pelaccio, D.G., Lapore, F.F., O'Connor, G.M., Rao, G.V.R., Ratekin, and G.H., Vogt, S.T., "Experimental Evaluation of an Advanced Space Shuttle Main Engine Hot-Gas Manifold Design Concept," AIAA 84-1463, 1984.

Perry, M., Eddy, N., Gruet, L., and Maw, J., "Design and Thermal Verification of the Space Shuttle Redesigned Solid Rocket Motor Field Joint", AIAA-1989-2775, ASME, SAE, and ASEE 25th Joint Propulsion Conference, Monterey, CA, July 10-13, 1989.

Pessin, Myron A., "Lessons Learned: from Space Shuttle External Tank Development - A Technical History of the External Tank," October 30, 2002.

Petroski, H., "To Engineer Is Human: The Role of Failure in Successful Design", St. Martin Press, New York, NY, 1982.

Petroski, H., "Design Paradigms: Case Histories of Error and Judgment in Engineering", Cambridge University Press, 1994.

Poole, R., "Beyond Engineering: How Society Shapes Technology," University Press, Oxford, New York, 1997.

Pugh, S., "Total Design", Addison-Wesley Publishing Co., New York, NY, 1991.

Pye, D., "The Nature of Design", Reichold Book Corp., New York, NY, 1969.

Rocketdyne Presentation, "Space Shuttle Main Engine Structural Audit and Weld Assessment", NASA Headquarters, April 24, 1989.

Rogers, W. P. (Chairman), et. al., "Report of the Presidential Commission on the Space Shuttle Challenger Accident", June 6, 1986.: <http://history.nasa.gov/rogersrep/genindex.htm>.

Ryan, R., S., "Influence of Wind Shears on Space Vehicle Design," Structures and Materials Panel Meeting, NATO, Paris, France, October 4, 1966.

Ryan, R., S., "The Use of Wind Shears in the Design of Aerospace Vehicles." Journal of Spacecraft and Rockets, Volume 4, No. 11. November 1967.

Ryan, R., S., "Dynamic Loads of a Launch Vehicle Due to Inflight Winds." New Orleans Joint AIAA Meeting, May 6, 1968.

Ryan, R. S. and King, A. W., "The Influential Aspect of Atmospheric Disturbances on Space Vehicle Design Using Statistical Approaches for Analysis." NASA TN-D-4963, January 1969.

Ryan R. S., et. al., "A Study of AS-502 Coupling Longitudinal Structural Vibration and Lateral Bending Response During Boost," AIAA Seventh Aerospace Science Meeting, AIAA Paper No. 69-58 New York, January 20-23, 1969.

Ryan R., S., "Vehicle Response to Atmospheric Disturbance", Chapter 7 in AGARDograph 115, "Wind Effects on Launch Vehicles", E. D. Geissler, Editor, The Advisory Group for Aerospace Research and Development, NATO, February 1970.

Ryan R. S., Kiefling L. A., and Buchanan, H. J., Simulation of Saturn V S-II Stage Propellant Feedline Dynamics, Jour. Of Space Craft, Vol. 7, No. 12. Dec 1970 .

Ryan, R., S., and Townsend, J., "Fundamental Issues in a Launch Vehicle Design," Journal of Spacecraft & Rockets, April 1977.

Ryan, R.S.; et al.: "Dynamic Testing of Large Space Systems," NASA TM-78307, September 1980.

Ryan, R. 1986, NASA Conference Publication 2467, Part 1 Structural Dynamics and Control Interaction of Flexible Structures Proceedings of a workshop held at George C. Marshall Space Flight Center Huntsville, Alabama April 22-24, 1986.

Ryan, R.S., "The Role of Failure/Problems in Engineering: A Commentary on Failures Experienced - Lessons Learned," NASA TP-3213, March 1992.

Ryan, R.S., Mowery, K., and Tomlin, D.D., "The Dynamic Phenomena of Tethered Satellite," NASA TP 3347, NASA, Washington DC, February 1993.

Ryan, R.S., "Robustness," AIAA Paper 93-0974, AIAA/AHS/ASEE Aerospace Design Conference, February 16-19, 1993.

Ryan, R.S., Gross, L. A., Mills, D., and Mitchell, P., "The Space Shuttle Main Engine Liquid Oxygen Pump High-Synchronous Vibration Issue, The Problem, The Resolution Approach, The Solution," AIAA 94-3153, presented at the 30th AIAA/ASME/SAE/ASEE Joint Propulsion Conference, Indianapolis, IN., June 27-29, 1994.

Ryan, R. S., and Gross, L. A., "Developmental Problems and Their Solution for the Space Shuttle Main Engine Alternate Liquid Oxygen High-Pressure Turbopump: Anomaly or Failure Investigation the Key", NASA Technical Paper 3553, May 1995.

Ryan R. S, J. Blair, J. Townsend, and V. Verderaiame, "Working on the Boundaries: Philosophies and Practices of the Design Process," NASA TP-3642, July 1996.

Ryan, R.S., "A History of Aerospace Problems, Their Solutions, Their Lessons" NASA Technical Paper 3653, September 1996.

Ryan, R., S. and Lassiter, J., "Shock and Vibration in the National Aeronautics and Space Administration", Chapter 6 in "50 Years of Shock and Vibration Technology", Pusey, Henry, (Editor), The Shock and Vibration Information Center, Booz, Allen, and Hamilton Inc. Arlington, VA, Nov. 1996.

Ryan, R.S., "Final Report of the X-33 Liquid Hydrogen Tank Test Investigation Team," May 2000.

Schutzenhofer, L. A., Howard, P. W., Clever, W. W., and Guest, S. H., "Space Shuttle Solid Rocket Booster Aft Skirt Reentry Noise Induced by an Aerodynamic Cavity-Flow Interaction," Shock and Vibration Bulletin, No. 49, Part 1, pp. 67-82, September 1979.

Schutzenhofer, L. A., Jones, J. H., Jewel, R. E., and Ryan, R. S., "Elimination of a Discrete Frequency Acoustical Phenomena Associated with the Space Shuttle Main Engine Oxidizer Valve-Duct System," presented at the 50th Shock and vibration Symposium, October 1979, Colorado Springs, CO, published in the 50th Shock and Vibration Symposium, September, 1980.

Skinner, B. F., "Beyond Freedom & Dignity". Bantam Books, New York, NY, 1972.

Senge, Peter M., "The Fifth Discipline" and "The Fifth Discipline Fieldbook" Bantam Doubleday Dell Publishing Co., New York, New York, 1990 & 1994.

Schock, R., "Solar Array Flight Dynamic Experiment," NASA TP 2598, May 1986.

Szalai, Kenneth J., et. al., "TSS-1R Mission Failure Investigation Board: Final Report", NASA TM-11246, 1996.

Thorndike, E.L., "Notes on Child Study" (1901), "Principles of Teaching" (1906), "Education: A First Book" (1912), and "The Psychology of Arithmetic" (1922).

Tournier, Paul, "A Place for You: Psychology and Religion", 1966.

Townsend, J., "Application of Probabilistic Analysis and Design Methods in Space Programs", Jour. of Spacecraft and Rockets Vol. 31, No. 6, November-December 1994.

Townsend, J., "Review of the Probabilistic Failure Analysis Methodology and Other Probabilistic Approaches for Application in Aerospace Structural Design" NASA Technical Paper 3434, 1993.

Tufte, Edward R., "Visual Explanations: Images and Quantitatives, Evidence and Narrative", Graphics Press, Cheshire, CT, 1997.

von Pragenau, George L., "Free Flight Simulated on Ground with the Apollo Saturn V Space Vehicle," Journal of Spacecraft and Rockets Vol 4, No. 9, September 1967.

Von Pragenau, G. L., "Damping Seals for Turbomachinery," NASA-TP-1987, March 1982.

Wheelwright, S.C., and Clark, K.B., "Revolutionizing Product Development: Quantum Leaps in Speed, Efficiency, and Quality," New York, Free Press, 1992.

Whitmore, John; "Coaching for Performance," Nicholas Brealey Publishing, London, 1997.

Zimmerman, F.R., Personal communication, 2010.

REPORT DOCUMENTATION PAGE

Form Approved
OMB No. 0704-0188

The public reporting burden for this collection of information is estimated to average 1 hour per response, including the time for reviewing instructions, searching existing data sources, gathering and maintaining the data needed, and completing and reviewing the collection of information. Send comments regarding this burden estimate or any other aspect of this collection of information, including suggestions for reducing this burden, to Department of Defense, Washington Headquarters Services, Directorate for Information Operation and Reports (0704-0188), 1215 Jefferson Davis Highway, Suite 1204, Arlington, VA 22202-4302. Respondents should be aware that notwithstanding any other provision of law, no person shall be subject to any penalty for failing to comply with a collection of information if it does not display a currently valid OMB control number.

PLEASE DO NOT RETURN YOUR FORM TO THE ABOVE ADDRESS.

| | | | | | | | | |
|--|--------------------|---------------------|--|--|----------------------------|---|--|--|
| 1. REPORT DATE (DD-MM-YYYY) 01-06-2011 | | | 2. REPORT TYPE Contractor Report | | | 3. DATES COVERED (From - To) | | |
| 4. TITLE AND SUBTITLE Lessons Learned in Engineering | | | | | | 5a. CONTRACT NUMBER NNM07AA77C | | |
| | | | | | | 5b. GRANT NUMBER | | |
| | | | | | | 5c. PROGRAM ELEMENT NUMBER | | |
| 6. AUTHOR(S) J.C. Blair, R.S. Ryan, and L.A. Schutzenhofer | | | | | | 5d. PROJECT NUMBER | | |
| | | | | | | 5e. TASK NUMBER | | |
| | | | | | | 5f. WORK UNIT NUMBER | | |
| 7. PERFORMING ORGANIZATION NAME(S) AND ADDRESS(ES) George C. Marshall Space Flight Center, Marshall Space Flight Center, AL 35812 Al Signal Research, Inc., 3411 Triana Blvd. SW, Huntsville, AL 35805 | | | | | | 8. PERFORMING ORGANIZATION REPORT NUMBER M-1317 | | |
| 9. SPONSORING/MONITORING AGENCY NAME(S) AND ADDRESS(ES) National Aeronautics and Space Administration Washington, DC 20546-0001 | | | | | | 10. SPONSORING/MONITOR'S ACRONYM(S) | | |
| | | | | | | 11. SPONSORING/MONITORING REPORT NUMBER NASA/CR-2011-216468 | | |
| 12. DISTRIBUTION/AVAILABILITY STATEMENT Unclassified-Unlimited Subject Category 15 Availability: NASA CASI (443-757-5802) | | | | | | | | |
| 13. SUPPLEMENTARY NOTES Prepared for the Organization & Leadership Development Office, Office of Human Capital COTR: James G. Andrews Supplemental Information is available on CD through CASI | | | | | | | | |
| 14. ABSTRACT This Contractor Report (CR) is a compilation of Lessons Learned in approximately 55 years of engineering experience by each James C. Blair, Robert S. Ryan, and Luke A. Schutzenhofer. The lessons are the basis of a course on Lessons Learned that has been taught at Marshall Space Flight Center. The lessons are drawn from NASA space projects and are characterized in terms of generic lessons learned from the project experience, which are further distilled into overarching principles that can be applied to future projects. Included are discussions of the overarching principles followed by a listing of the lessons associated with that principle. The lesson with sub-lessons are stated along with a listing of the project problems the lesson is drawn from, then each problem is illustrated and discussed, with conclusions drawn in terms of Lessons Learned. The purpose of this CR is to provide principles learned from past aerospace experience to help achieve greater success in future programs, and identify application of these principles to space systems design. The problems experienced provide insight into the engineering process and are examples of the subtleties one experiences performing engineering design, manufacturing, and operations. | | | | | | | | |
| 15. SUBJECT TERMS launch/spacecraft vehicles, propulsion, design, testing, failure analysis | | | | | | | | |
| 16. SECURITY CLASSIFICATION OF: | | | 17. LIMITATION OF ABSTRACT | | 18. NUMBER OF PAGES | | 19a. NAME OF RESPONSIBLE PERSON | |
| a. REPORT | b. ABSTRACT | c. THIS PAGE | UU | | 238 | | STI Help Desk at email: help@sti.nasa.gov | |
| U | U | U | | | | | 19b. TELEPHONE NUMBER (Include area code) STI Help Desk at: 443-757-5802 | |

National Aeronautics and
Space Administration
IS20

George C. Marshall Space Flight Center

Marshall Space Flight Center, Alabama

35812