

NASA/TM—2011-217005

NETS 2011-3316



“Scotty, I Need More Power”—The Fission System Gateway to Abundant Power for Exploration

*Donald T. Palac
Glenn Research Center, Cleveland, Ohio*

NASA STI Program . . . in Profile

Since its founding, NASA has been dedicated to the advancement of aeronautics and space science. The NASA Scientific and Technical Information (STI) program plays a key part in helping NASA maintain this important role.

The NASA STI Program operates under the auspices of the Agency Chief Information Officer. It collects, organizes, provides for archiving, and disseminates NASA's STI. The NASA STI program provides access to the NASA Aeronautics and Space Database and its public interface, the NASA Technical Reports Server, thus providing one of the largest collections of aeronautical and space science STI in the world. Results are published in both non-NASA channels and by NASA in the NASA STI Report Series, which includes the following report types:

- **TECHNICAL PUBLICATION.** Reports of completed research or a major significant phase of research that present the results of NASA programs and include extensive data or theoretical analysis. Includes compilations of significant scientific and technical data and information deemed to be of continuing reference value. NASA counterpart of peer-reviewed formal professional papers but has less stringent limitations on manuscript length and extent of graphic presentations.
- **TECHNICAL MEMORANDUM.** Scientific and technical findings that are preliminary or of specialized interest, e.g., quick release reports, working papers, and bibliographies that contain minimal annotation. Does not contain extensive analysis.
- **CONTRACTOR REPORT.** Scientific and technical findings by NASA-sponsored contractors and grantees.

- **CONFERENCE PUBLICATION.** Collected papers from scientific and technical conferences, symposia, seminars, or other meetings sponsored or cosponsored by NASA.
- **SPECIAL PUBLICATION.** Scientific, technical, or historical information from NASA programs, projects, and missions, often concerned with subjects having substantial public interest.
- **TECHNICAL TRANSLATION.** English-language translations of foreign scientific and technical material pertinent to NASA's mission.

Specialized services also include creating custom thesauri, building customized databases, organizing and publishing research results.

For more information about the NASA STI program, see the following:

- Access the NASA STI program home page at <http://www.sti.nasa.gov>
- E-mail your question via the Internet to help@sti.nasa.gov
- Fax your question to the NASA STI Help Desk at 443-757-5803
- Telephone the NASA STI Help Desk at 443-757-5802
- Write to:
NASA Center for AeroSpace Information (CASI)
7115 Standard Drive
Hanover, MD 21076-1320



“Scotty, I Need More Power”—The Fission System Gateway to Abundant Power for Exploration

*Donald T. Palac
Glenn Research Center, Cleveland, Ohio*

Prepared for the
Nuclear and Emerging Technologies for Space (NETS-2011)
cosponsored by the ANS Aerospace Nuclear Science and Technology Division, the ANS Trinity Section,
and the AIAA
Albuquerque, New Mexico, February 7–10, 2011

National Aeronautics and
Space Administration

Glenn Research Center
Cleveland, Ohio 44135

Acknowledgments

The author wishes to thank the members of the National Aeronautics and Space Administration/Department of Energy/Industry Fission Surface Power/Fission Power Systems team for the honor of being associated with one of the best-integrated cross-organizational teams anyone could ask to work with. The support of the Exploration Technology Development Program, and the Enabling Technology Development and Demonstration Formulation Team is greatly appreciated. Likewise, the open-mindedness and creativity of the Constellation/Lunar Surface System and Mars Planning organizations for being willing to listen to the Fission Power story and having the courage to act on it will not soon be forgotten. Finally the support of the NASA Headquarters/Exploration Systems Mission Directorate, Advanced Capabilities Division and Department of Energy/Nuclear Energy is greatly appreciated.

Trade names and trademarks are used in this report for identification only. Their usage does not constitute an official endorsement, either expressed or implied, by the National Aeronautics and Space Administration.

Level of Review: This material has been technically reviewed by technical management.

Available from

NASA Center for Aerospace Information
7115 Standard Drive
Hanover, MD 21076-1320

National Technical Information Service
5301 Shawnee Road
Alexandria, VA 22312

Available electronically at <http://www.sti.nasa.gov>

“Scotty, I Need More Power”—The Fission System Gateway to Abundant Power for Exploration

Donald T. Palac
National Aeronautics and Space Administration
Glenn Research Center
Cleveland, Ohio 44135

Abstract

In planning and in crisis, electrical power has been a key consideration when humans venture into space. Since the 1950’s, nuclear fission (splitting of atoms) power has been a logical alternative in both fact and fiction, due to its ability to provide abundant power with high energy density, reliability, and immunity to severe environments. Bringing space fission power to a state of readiness for exploration has depended on clearing the hurdle of technology readiness demonstration. Due to the happy coincidence of heritage from prior space fission development efforts such as the Prometheus program, foresight from NASA’s Exploration Mission Systems Directorate in the mid-2000’s, and relative budget stability through the late 2000’s, National Aeronautics and Space Administration (NASA) and Department of Energy (DOE), with their industry partners, are poised to push through to this objective. Hardware for a 12 kWe non-nuclear Fission Power System Technology Demonstration Unit is being fabricated now on a schedule that will enable a low-cost demonstration of technology readiness in the mid-2010s, with testing beginning as early as 2012. With space fission power system technology demonstrated, exploration mission planners will have the flexibility to respond to a broad variety of missions and will be able to provide abundant power so that future explorers will, in planning or crisis, have the power they need when they most need it.

Introduction

In life as in fiction, the availability of abundant power, especially in a small package, can liberate the imagination. We have heated and lit our homes and streets, crossed continents and oceans, and sent robots beyond the influence of the Sun by harnessing sources of energy and turning them to our purposes. Our imaginings of the future have included everything from flying cars to starships that warp space-time. Often, in life and fiction, limited power availability can lead to disappointment, frustration, and even danger. Nearly eclipsing the first landing on the Moon, the world held its breath as the Apollo 13 command module returned to Earth, uncertain if enough power remained to control the reentry and deploy parachutes. Those responsible for supplying power to enable humankind’s endeavors bear the frustration that our systems never seem to supply enough power, reliably enough, to all the places power is needed, in a small enough and light enough package. These challenges turn us increasingly to higher energy density in our power systems, and the post-WWII excitement at harnessing the atom was in part related to the energy density of nuclear systems. Perhaps an echo of that excitement can be heard in the realization that nuclear power is an important part of the solution to keeping up with the increasing global energy demand while minimizing impact to the environment. Simultaneously, recent interest in extending human presence into space has resulted in advancements in the technology readiness of fission power systems for use on spacecraft and planetary surfaces. With a continuation of this interest for just a few more years, a major gateway to the use of fission power in space can be opened, that will allow potential users to go forward with the development of space fission power systems with confidence that the system level technology readiness has been established.

Recent revival of interest in space fission power began with NASA’s Prometheus program of the early 2000’s, which envisioned the use of 100’s of kilowatts to enable multiple encounters with Jupiter’s major moons on one mission by use of electric propulsion, with that same abundant level of power available for

science instruments while coasting in the moons' vicinity. While short-lived, the Prometheus program's investments in analysis and design of space fission power systems refreshed interest and capabilities in those areas, while investments in power conversion and heat rejection technology development resulted in an increased readiness for future space fission power system requirements. NASA changed its focus to President George W. Bush's Vision for Space Exploration in 2004, instigating the recapture and updating of prior studies of fission power for the surfaces of the Moon and Mars, as well as calling for evolving Prometheus program investments. The Vision for Space Exploration's focus on "go as you pay" meant a challenge to the space fission community to make cost and risk minimization the first priority after safety in identifying the approach to space fission power for human exploration. NASA and DOE, with industry's assistance, responded to this challenge by defining an approach to power system for the surface of the Moon or Mars that relies heavily on components and subsystems with prior space and terrestrial fission power experience, especially those involved in the reactor. This approach resulted in a surface power concept that meets expected lunar/Mars surface requirements and avoids high risk/high cost new developments, at a system mass that is compatible with surface mission requirements.

NASA is currently in the midst of examining strategic approaches to a flexible path for human exploration. Because the planning is just beginning, the requirements for missions included in any given path are not yet known. However, it is expected that low risk and cost are likely to be continued emphases of any given path. At the same time, the push for new approaches to human exploration also includes an emphasis on going beyond Earth orbit, with Mars as an eventual goal. Because of Mars's distance from the Sun and its atmosphere-borne dust, most previous assessments of Mars surface exploration power system requirements have identified fission power as enabling for human missions. If a goal of steps on a flexible path to Mars is to demonstrate capabilities need to extend human presence to Mars and beyond, then it appears prudent to demonstrate space fission power as part of these steps. Some missions envisioned in emerging studies of flexible paths may call for a fission power system with different requirements than surface missions, such as lower specific mass and higher power levels. The low cost, low risk approach applied to fission surface power can serve as a starting point for cost and risk minimization of these flexible path power systems. Fission power systems scale well to higher power levels, it may be possible to preserve much of the low cost and risk features in higher power fission systems. In addition, it will be shown later in this paper that significant investment and momentum exists now for the establishment by the mid-2010's of fission power system-level technology readiness in a relevant environment, based on the lunar/Mars surface expected requirements. Continuation of this technology development effort now, leveraging prior investments and sustaining existing momentum, has the potential for establishing an important gateway for fission power system flight hardware development for a variety of future missions.

Nomenclature

AFSPSS	Affordable Fission Surface Power System Study
DOE	Department of Energy
EP	Electric Propulsion
ESMD	Exploration Mission Systems Directorate
ETDD	Enabling Technology Development and Demonstration
ETDP	Exploration Technology Development Program
FCS	Facility Cooling System
FPS	Fission Power System
FSP	Fission Surface Power
FSPS	Fission Surface Power System
FY	Fiscal Year

GRC	Glenn Research Center
HR	Heat Rejection
HRS	Heat Rejection System
HRU	Heat Rejection Unit
HX	Heat Exchanger
I&C	Instrumentation and Controls
INL	Idaho National Laboratory
ISRU	In-Situ Resource Utilization
ISS	International Space Station
kg	kilogram
kW	kilowatts
kWe	kilowatts (electric)
kWt	kilowatts (thermal)
LaNL	Los Alamos National Laboratory
m	meter
MSFC	Marshall Space Flight Center
NaK	Sodium/Potassium mixture
NASA	National Aeronautics and Space Administration
NEO	Near Earth Object
NEP	Nuclear Electric Propulsion
ORNL	Oak Ridge National Laboratory
PCU	Power Conversion Unit
PMAD	Power Management and Distribution
RDU	Radiator Demonstration Unit
rem	Roentgen Equivalent Man
Rx	Reactor
Rx Sim	Reactor Simulator
S/C	Spacecraft
SNL	Sandia National Laboratory
TDU	Technology Demonstration Unit
TRL	Technology Readiness Level

Review of Low Risk/Cost Principles for Space Fission Power

The Fission Surface Power Systems (FSPS) project was initiated and included into the ESMD Exploration Technology Development Program in 2007 to develop system level technology that provides the option for fission surface power for the U.S. Space Exploration Policy (formerly the Vision for Space Exploration). The goals, elements, and plans of the FSPS project have been explained in detail previously; the project key goals are to:

- Develop a FSPS concept that meets surface power requirements at reasonable cost with added benefits over competitive options
- Establish a hardware-based technical foundation for FSPS design concepts that reduces risk

- Reduce the cost uncertainties for FSPS and establish greater credibility for flight system cost estimates
- Generate the key gate products that would allow Agency decision-makers to consider FSPS as a viable option to proceed to flight development

The first responsibility of the FSPS project was to undertake the Affordable Fission Surface Power System Study (AFSPSS), a collaborative effort that included participation from NASA, DOE, and nuclear industry expert consultants, with review by industry. The study team identified strategies to achieve affordability that included:

- Modest requirements and operating conditions
- Selection of a well-established reactor concept
- Significant terrestrial operational experience, SNAP-10A space flight operations, and significant prior space fission power system development experience; see Bennett (1996) and Teofilo (2006).
- Large fabrication experience (low cost)
- Large operational database
- Reactor design for self regulation of perturbations with large margins
- Robust control system
- Extensive reliance on existing terrestrial and prior space nuclear power systems databases

Application of these strategies resulted in a FSP concept with the characteristics as shown in Table 1 and Figure 1. The high energy density of nuclear power enabled a favorable trade on mass with risk and complexity, furthered also by the dominance of reactor and shielding mass with respect to the overall system mass.

TABLE 1.—AFSPSS PRELIMINARY BASIS FOR AFFORDABILITY

Power level and Design life	<ul style="list-style-type: none"> • 40 kWe, 5-8 years
Design approach	<ul style="list-style-type: none"> • 900 K liquid-metal cooled reactor with UO₂ fuel (terrestrial design basis), less than 200 kWt thermal power level • Stirling power conversion with 850 K input, ~10 kWe/Stirling engine • 400 K water radiators (ISS-derived), <200 m² • 400 V transmission, 120 V bus (ISS-derived) for loads
Technology needs	<ul style="list-style-type: none"> • Liquid metal primary loop and Stirling hot-end interface • End-to-end system performance test (TDU) • Reactor criticality benchmarking tests
Launch and Startup	<ul style="list-style-type: none"> • Up to two units delivered on a single lunar lander • Reactor startup after installation and crew inspection
Mission and Environment	<ul style="list-style-type: none"> • One of several power sources for crew and equipment; backup power and crew availability provide contingency options • Technology and concept design extensible to Mars surface missions • Lunar day/night cycle, 50 to 350 K sink, accommodation of dust

- Modular 40 kWe system with 8-year design life suitable for (global) lunar and Mars surface applications
- Emplaced configuration with regolith shielding augmentation permits near-outpost siting (<5 rem/yr at 100 m separation)
- Low temperature, low development risk, liquid-metal (NaK) cooled reactor with UO_2 fuel and stainless steel construction

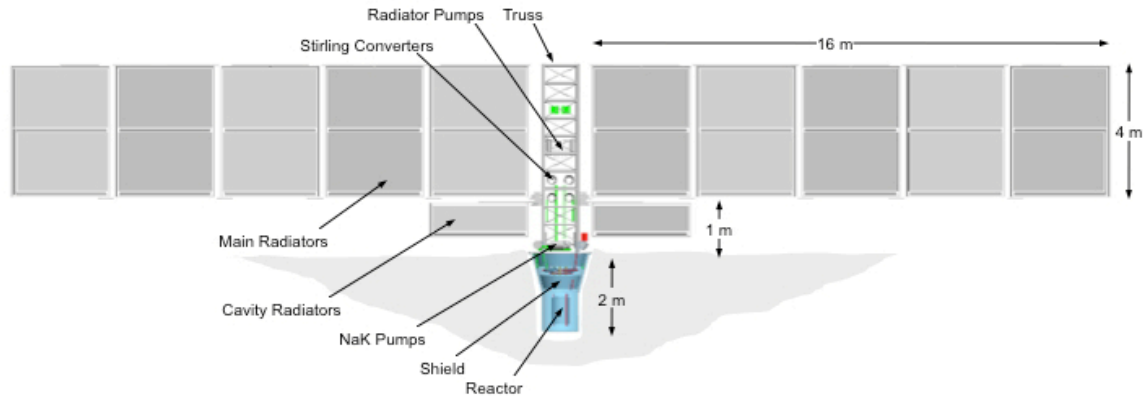

Figure 1.—Fission surface power reference concept.

The FSPS affordable design philosophy is founded in principles of conservatism, simplicity, and robustness. Conservatism was employed in the selection of the highest temperature in the entire system of 900 K, allowing the use of stainless steel and other non-refractory materials for structure. Conservatism also dictated that the conceptual operation and performance of the FSP system would be kept well within the existing experience database from terrestrial and prior space nuclear power systems testing and operations. The application of the principle of simplicity resulted in the selection of modest power level (40 kWe) and life (8 years) goals for the FSP conceptual design, translating to large margins against any possibility of uncommanded criticality (start up) of the reactor, and the inclusion of negative temperature reactivity feedback across the operating range of the reactor. This feature causes reactor reactivity to drop as temperature increases, resulting in a self-regulating characteristic of reactor operation that simplifies power system monitoring and control. Robustness, the availability of significant margin on operating conditions, is to a large extent an intrinsic result of the principle of conservatism. However, employment of available margin to increased redundancy, structural capability, and fault tolerance, rather than performance, has direct benefits in reduced risks and costs. A more complete treatment of these applied principles can be found in Palac (2009).

Status of Fission Power System Technology Development

In May, 2007, the NASA Associate Administrator for Exploration approved the AFSPSS results and directed the continuation of the FSPS project's technology development. The project undertook a series of "Pathfinder" activities to validate the technology readiness of component and subsystem technologies in preparation for its main goal of system-level technology readiness validation. Finalization of the FSP reference concept definition in parallel to the Pathfinder tests culminated in the preparation of the FSP system level non-nuclear (i.e., electrically heated) Technology Demonstration Unit (TDU) specification in 2009, with subsequent initiation of TDU design, development, and procurement activities.

Pathfinder Testing Status

Major elements of a fission space power system include the reactor and heat transfer loop, power conversion, and heat rejection. Pathfinder testing has been completed for components and subsystems for each of these elements. Figure 2 gives an overview of the Pathfinder testing. Highlights of the Pathfinder testing are summarized in the following sections. More details are available in Palac (2010).

Reactor Simulator and Heat Transfer Loop

As described above, the low risk/cost approach to space fission power is a result of minimization of reactor system technology development. However, the technology of simulating an FSP reactor with electrical heating required development and demonstration. Building on work started under the Prometheus space nuclear power and propulsion program earlier this decade, NASA Marshall Space Flight Center (MSFC) and the DOE undertook development of reliable high energy density electrical heater bundles that can simulate nuclear reactor components. In 2010, a 7-element bundle of electric heaters was tested in a configuration simulating a nuclear reactor fuel element bundle, providing heat to a liquid metal NaK heat transfer fluid at 875 K; see Godfroy (2011). Transferring heat from the reactor simulator to the power conversion unit requires pumping of liquid metal NaK. Electromagnetic pumps have been used in terrestrial liquid metal reactors, but none of the type suitable for an FSPS have been manufactured for over 15 years. An electromagnetic Annular Linear Induction Pump (ALIP) was fabricated by Idaho National Laboratory and Pacific Northwest National Laboratory and tested in 2009. It delivered a pressure head of 58 to 68 kPa at a flow rate of approximately 4 kg/s as designed; see Polzin (2010).

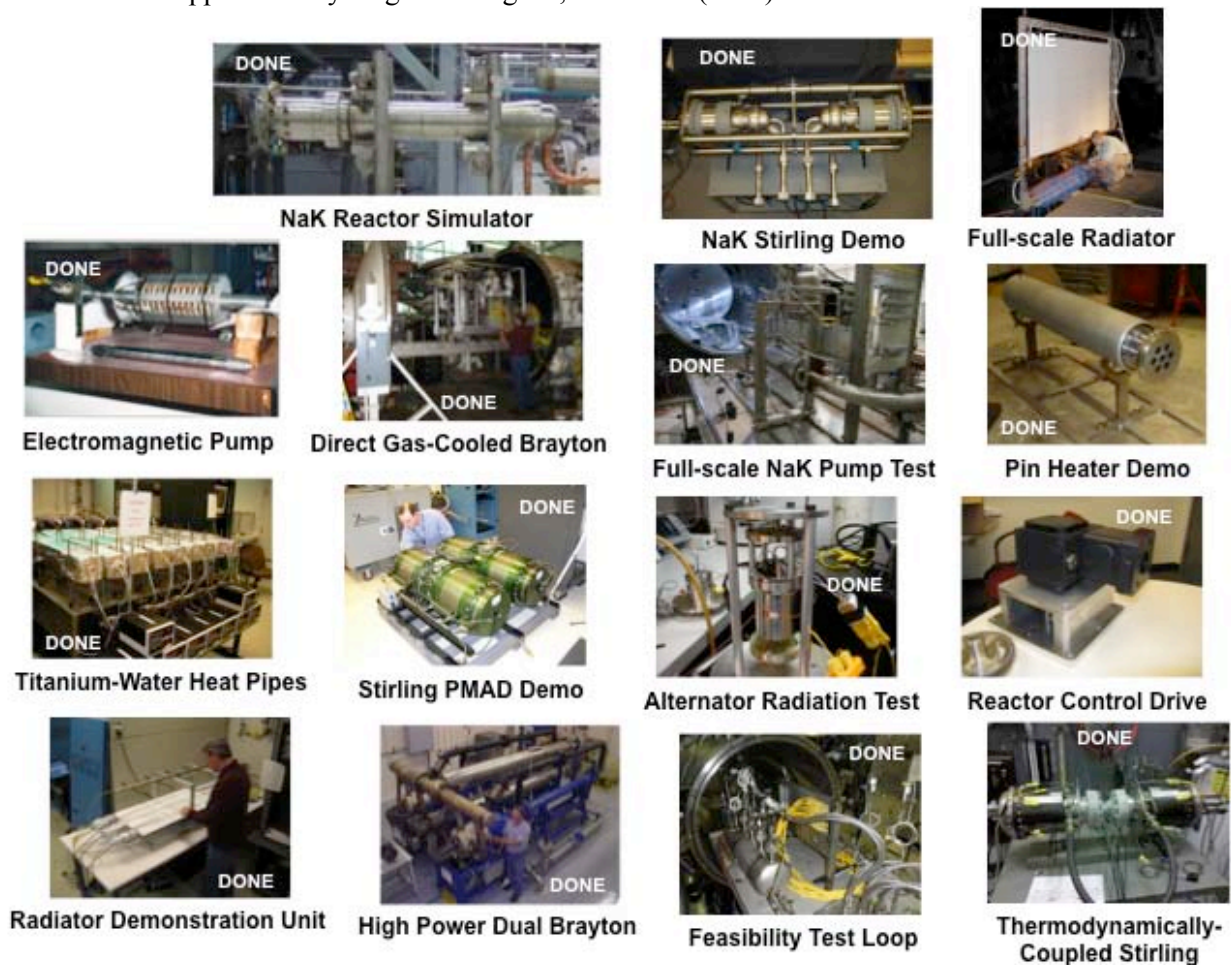

Figure 2.—Fission surface power pathfinder test summary.

Power Conversion

Demonstration of Stirling engine readiness at multi-kilowatt electrical power levels was an important Pathfinder prerequisite to proceeding to full scale TDU power conversion unit design and fabrication. In addition, Stirling engine operation with heat supplied via liquid metal NaK had never been demonstrated prior to the FSPS Pathfinder demonstration. NASA Glenn Research Center (GRC), in conjunction with Sunpower, Inc., modified a commercial Stirling engine design to meet the requirements of a Pathfinder demonstration unit, and Sunpower fabricated two 1 kWe Stirling engines. GRC added liquid metal NaK heat exchangers to the engines, which were subsequently installed and tested in MSFC's Primary Test Circuit laboratory. The NaK-heated Stirling pair demonstrated 2.4 kWe of power (as expected, slightly over the nominal 2 kWe rating of the combined engine set because the test conditions fall in the optimal range of engine operation), with a more-uniform-than-expected circumferential temperature distribution in the NaK heat exchanger, indicating low structural stresses in this critical interface. This accomplishment provides confidence for proceeding with the detailed design and fabrication of a full scale 12 kWe Stirling power conversion unit for the FSPS TDU; see Briggs (2010).

Heat Rejection

The FSPS heat rejection system must reject approximately 140 kWt of thermal power from the power conversion module at a temperature of 400 K or more. Titanium-water heat pipes embedded in composite radiators were selected as the most suitable technologies for these conditions, leveraging Prometheus Jupiter Icy Moons Orbiter mission studies. A full scale "2nd Generation" Radiator Demonstration Unit (RDU) was designed and developed by Material Innovations, Inc. in 2008 to 2009. This RDU included a water manifold to deliver heat to the evaporator ends of the heat pipes, the heat pipes themselves, and the 1.7 m tall by 2.7 m wide composite radiator panels that radiate the heat distributed through the panel by the heat pipes. The RDU was tested over the summer of 2009 in the GRC Vacuum Facility 6, and it successfully demonstrated the rejection of 6 kWt of heat as designed under simulated lunar conditions; see Ellis (2011).

Technology Demonstration Unit Status

The TDU is an end-to-end system test of a reactor simulator (Rx Sim), Power Conversion Unit (PCU), and Heat Rejection System (HRS) in thermal-vacuum as shown in Figure 3. The TDU is intended to demonstrate the major elements of a notional Fission Surface Power System (FSPS) using a non-nuclear heat source. The Rx Sim includes an electrical resistance heat source and a liquid metal (sodium potassium or NaK) heat transport loop. It simulates the reactor thermal interface and expected dynamic response. The PCU generates electric power utilizing the heated liquid metal and rejects waste heat to the HRS. The HRS includes a pumped water-cooling loop coupled to vertical radiator panels suspended in the thermal-vacuum facility. An intermediate test configuration, prior to the installation of the HRS, includes

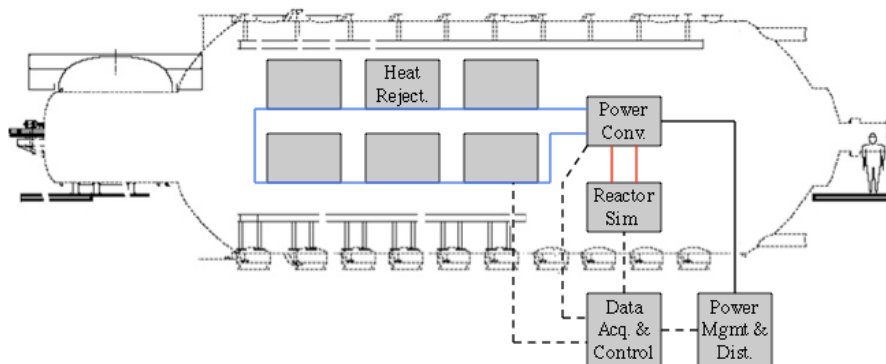

Figure 3.—TDU test layout.

a Facility Cooling System (FCS) to reject PCU waste heat utilizing an external heat exchanger. The data acquisition and control, and power management and distribution equipment would be external to the vacuum facility and provide prototypic functionality using commercially available, rack-mounted components.

TDU Reactor Simulator Status

The successful completion of the 7-element Pathfinder electrical heater bundle test paved the way for fabrication of the 37-pin TDU Core Simulator. The TDU Core Simulator is designed to deliver as much as 90 kWt to the NaK heat transfer fluid loop at 875 K, and power and temperature can be varied across a range of planned TDU test conditions. The TDU Core Simulator fabrication was recently completed by MSFC, supported by Idaho, Los Alamos, Oak Ridge, and Sandia National Laboratories. Figure 4 shows the completed hardware. Major portions of the TDU Annular Linear Induction Pump were fabricated by Idaho and Pacific Northwest National Laboratories. Final assembly of the pump awaits delivery of materials to complete the electromagnetic induction circuitry. The pump will be tested in a liquid metal NaK test loop at MSFC before being installed in the TDU Reactor Simulator. Oak Ridge National Laboratory has delivered the TDU Volume Accumulator, which will assist in filling the TDU NaK loop and allow for fluid volume variations during testing. MSFC has fabricated the primary platform of the TDU Reactor Simulator Mounting Structure, which will support the Reactor Simulator components during pre-TDU verification testing, and will provide for integration with the remainder of the TDU when delivered to GRC.

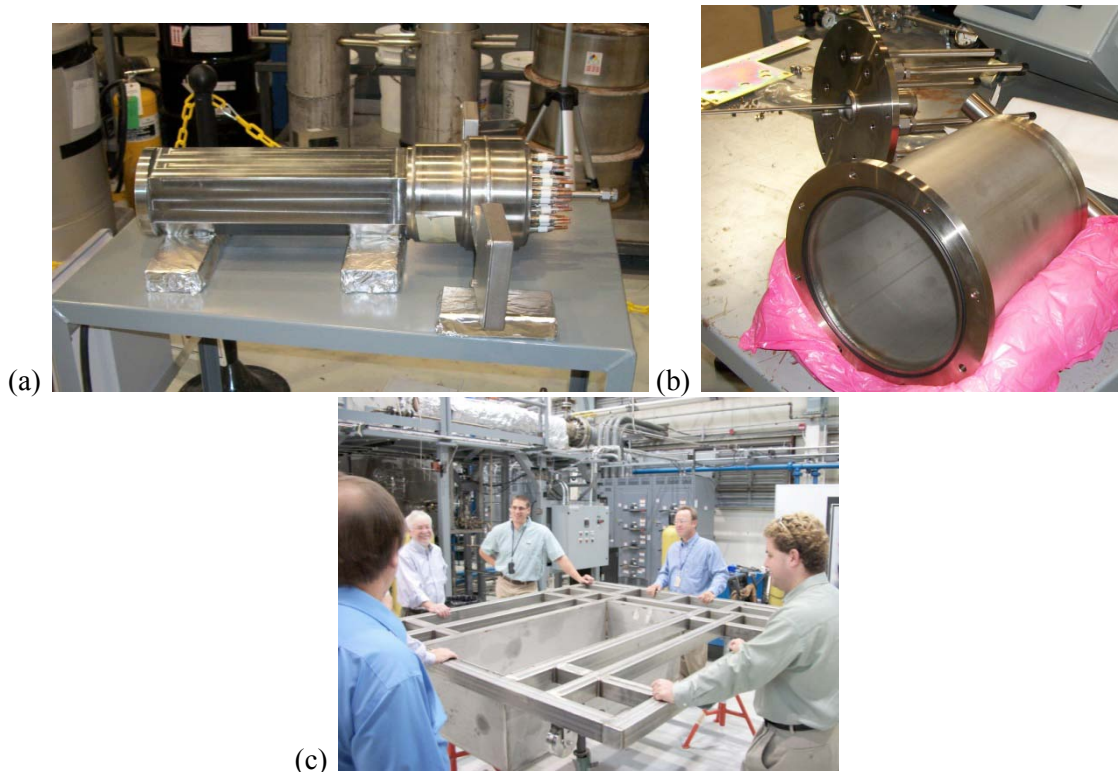

Figure 4.—(a) TDU core simulator, (b) Volume accumulator, and (c) Mounting structure at MSFC.

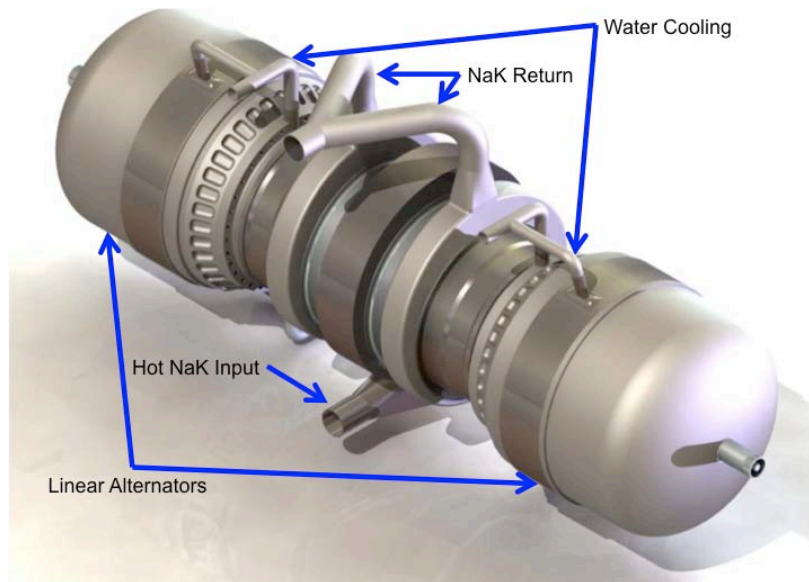

Figure 5.—TDU power conversion unit design (Sunpower, Inc.).

TDU Power Conversion Unit (PCU) Status

Sunpower, Inc. began the design and development of the Power Conversion Unit for the TDU in April, 2009, and is on schedule for delivery of a 12 kWe PCU consisting of two thermodynamically-coupled 6 kWe Stirling engines in the winter of 2011-12. The PCU, like the rest of TDU, will be a full-scale technology demonstrator of FSP hardware. A full scale FSP delivering 40 kWe will have four PCUs (8 kWe in excess of user loads is for FSP internal loads and accommodation of losses), so the TDU will be mostly full scale at 1/4 power of the FSP concept; see Wood (2011). A preliminary graphic of the PCU is shown in Figure 5.

TDU Heat Rejection Unit (HRU) Status

The successful completion of the Pathfinder Radiator Demonstration Unit testing of a full-scale panel radiator panel established the technology readiness of the heat rejection concept for FSP. The basis exists for the development of a specification for the procurement of a TDU Heat Rejection Unit, which will accept the rejected heat from the Stirling Power Conversion Unit of as much as 36 kWt via six radiator panels in the GRC Vacuum Facility 6 with liquid nitrogen cold walls to simulate the lunar environment. The TDU assembly and testing is phased to reduce risk, with the Reactor Simulator testing completed first at MSFC, the Reactor Simulator and PCU integration and testing with a water Facility Cooling System substituting for the Heat Rejection Unit, and lastly full integration of the TDU including the HRU. Because of funding limitations and the delayed need for the HRU, start of HRU design is not currently planned until the end of 2012.

TDU Summary Schedule

Figure 6 shows the TDU summary schedule. Red indicates the Reactor Simulator element, yellow is the first phase of the TDU without the HRU, and green is the fully integrated TDU. It is clear from the schedule that much of the preparation and planning for the TDU has been accomplished, and that two of three major elements are in fabrication. Not explicit in the schedule is the magnitude of knowledge and experience that has been built up in the past several years in a team that has focused on bringing the technology readiness of space fission power to a system level. The record of success and the momentum required to complete the job supports a compelling rationale that now is the time to establish this benchmark.

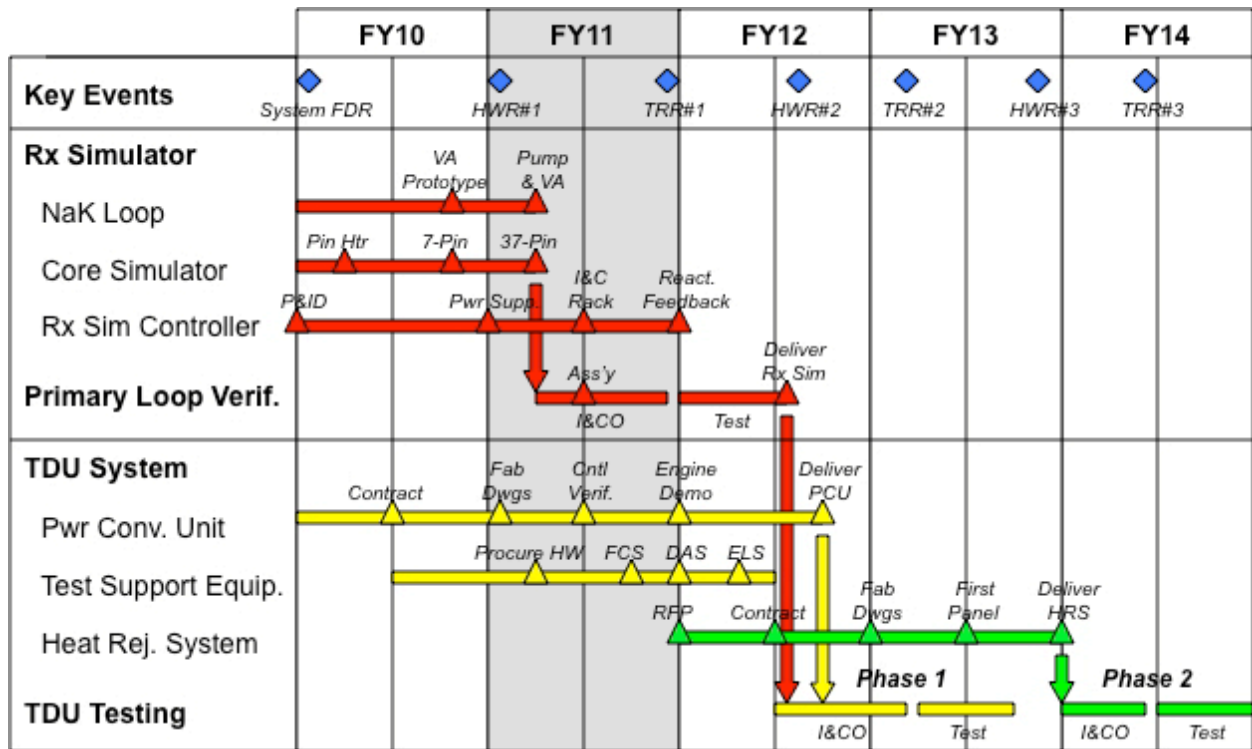

Figure 6.—TDU summary schedule.

Conclusions

Significant experience exists in terrestrial and prior space fission power systems development, testing, and operation, and this experience has provided solid foundation for reduction of risk and cost in space fission power system development via the availability of large databases of information on performance and operations of fission systems. Staying well within the margins of this experience base has the potential to keep fission system development and deployment no more costly than other aerospace systems of similar complexity. In the past few years, the Fission Surface Power Systems project has explored the application of principles of low risk/cost to fission systems concept definition and technology development. Successful completion of a number of Pathfinder readiness validation activities, along with the on-schedule current development and fabrication of a non-nuclear system-level fission power Technology Demonstration Unit, have established that the momentum, experience, and progress exist now to push through to the benchmarking space fission power technology readiness for future missions.

Abundant power is as important for future space exploration missions as it has ever been. Mars remains a major waypoint in the expansion of human presence into the solar system, and the enabling nature of fission power for human exploration on the Martian surface has been well established. Demonstration of fission power in space prior to Mars is prudent, and may have multiple benefits to a variety of other capabilities that will be necessary for the expansion of human presence (Figure 7 illustrates notionally some examples). Following through on the progress of the last several years clearly offers the potential to open the gateway to abundant power for future generations of space explorers, who need never give voice to the expression, "...I need more power."

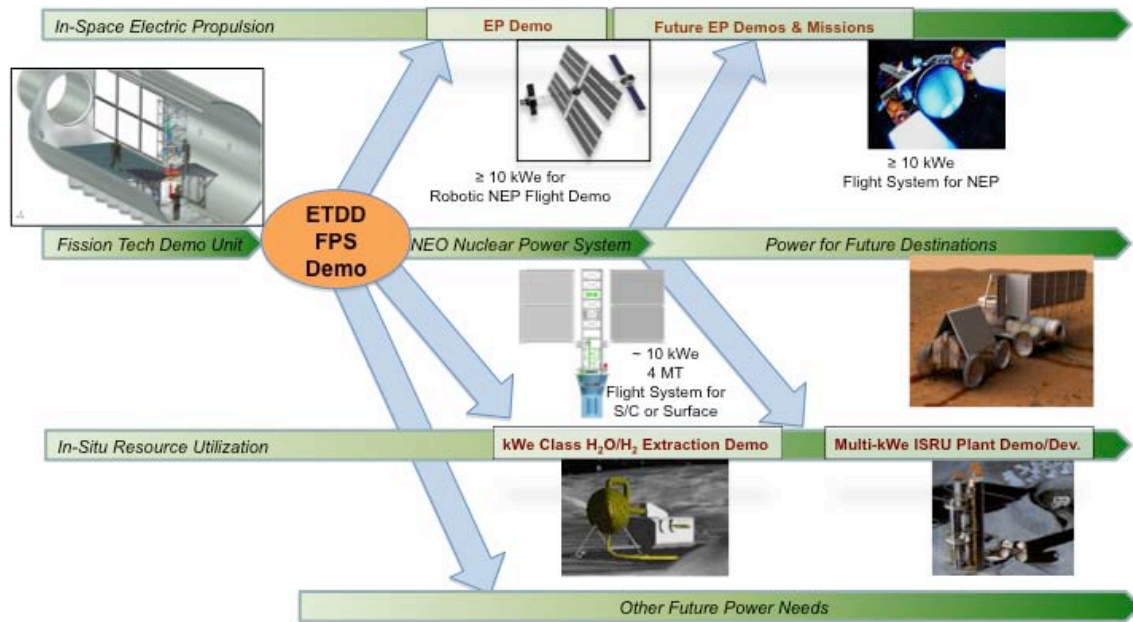

Figure 7.—Fission power system technology demonstration: the gateway to abundant power.

References

- Bennett, G.L., Hemler, R.J., and Schock, A., “Space Nuclear Power: An Overview,” in *Journal of Propulsion and Power*, Vol. 12, No. 5, September-October 1996.
- Briggs, M.H., et al., “Summary of Test Results from a 1 kWe-Class Free-Piston Stirling Power Converter Integrated With a Pumped NaK Loop,” NASA/TM—2010-216934, July, 2010.
- Drake, B., “Human Exploration of Mars Design Reference Architecture 5.0,” NASA/SP-2009-566, July 2009.
- Ellis, D.L., et al., “Manufacture, Testing, and Model Validation of a Full-Scale Radiator for Fission Surface Power Application,” in *Proceedings of Nuclear and Emerging Technologies for Space 2011*, Paper no. 3181, Albuquerque, NM, February, 2011.
- Godfroy, T., “Design and Build of Reactor Simulator for Fission Surface Power Technology Demonstration Unit,” in *Proceedings of Nuclear and Emerging Technologies for Space 2011*, Paper no. 3508, Albuquerque, NM, February, 2011.
- Obama, B., “Remarks by the President on Space Exploration in the 21st Century,” The White House Office of the Press Secretary, John F. Kennedy Space Center, Merritt Island, Florida, 2010.
- Palac, D., Mason, L., and Harlow, S., “Fission Surface Power Technology Development Status,” NASA/TM—2009-215602, March, 2009.
- Palac, D., Mason, L., and Harlow, S., “Fission Surface Power Technology Development Status,” NASA/TM—2010-216249, April, 2009.
- Palac, D., Mason, L., and Harlow, S., “Fission Surface Power Technology Development Update,” AIAA-2010-8711, August, 2010.
- Polzin, K.A. and Pearson, J.B., et al., “Performance Testing of a Prototypic Annular Linear Induction Pump for Fission Surface Power,” NASA/TP—2010-216430, July 2010.
- Parfit, M., “Future Power,” in *National Geographic Magazine*, August, 2005, pp. 23–27.
- Teofilo, V.L., “Space Power Systems for the 21st Century,” in *Proceeding of Space 2006 Conference*, AIAA-2006-7288, September, 2006, pp. 7–9.
- Wood, J.G. et al., “The Design and Development of a 12 kWe Stirling Power Conversion Unit for Fission Power Technology Demonstration,” in *Proceedings of Nuclear and Emerging Technologies for Space 2011*, Paper no. 3488, Albuquerque, NM, February, 2011.

REPORT DOCUMENTATION PAGE			Form Approved OMB No. 0704-0188		
<p>The public reporting burden for this collection of information is estimated to average 1 hour per response, including the time for reviewing instructions, searching existing data sources, gathering and maintaining the data needed, and completing and reviewing the collection of information. Send comments regarding this burden estimate or any other aspect of this collection of information, including suggestions for reducing this burden, to Department of Defense, Washington Headquarters Services, Directorate for Information Operations and Reports (0704-0188), 1215 Jefferson Davis Highway, Suite 1204, Arlington, VA 22202-4302. Respondents should be aware that notwithstanding any other provision of law, no person shall be subject to any penalty for failing to comply with a collection of information if it does not display a currently valid OMB control number.</p> <p>PLEASE DO NOT RETURN YOUR FORM TO THE ABOVE ADDRESS.</p>					
1. REPORT DATE (DD-MM-YYYY) 01-05-2011		2. REPORT TYPE Technical Memorandum		3. DATES COVERED (From - To)	
4. TITLE AND SUBTITLE "Scotty, I Need More Power"--The Fission System Gateway to Abundant Power for Exploration			5a. CONTRACT NUMBER		
			5b. GRANT NUMBER		
			5c. PROGRAM ELEMENT NUMBER		
6. AUTHOR(S) Palac, Donald, T.			5d. PROJECT NUMBER		
			5e. TASK NUMBER		
			5f. WORK UNIT NUMBER WBS 463169.01.03.01.01		
7. PERFORMING ORGANIZATION NAME(S) AND ADDRESS(ES) National Aeronautics and Space Administration John H. Glenn Research Center at Lewis Field Cleveland, Ohio 44135-3191			8. PERFORMING ORGANIZATION REPORT NUMBER E-17667		
9. SPONSORING/MONITORING AGENCY NAME(S) AND ADDRESS(ES) National Aeronautics and Space Administration Washington, DC 20546-0001			10. SPONSORING/MONITOR'S ACRONYM(S) NASA		
			11. SPONSORING/MONITORING REPORT NUMBER NASA/TM-2011-217005		
12. DISTRIBUTION/AVAILABILITY STATEMENT Unclassified-Unlimited Subject Category: 20 Available electronically at http://www.sti.nasa.gov This publication is available from the NASA Center for AeroSpace Information, 443-757-5802					
13. SUPPLEMENTARY NOTES					
14. ABSTRACT In planning and in crisis, electrical power has been a key consideration when humans venture into space. Since the 1950's, nuclear fission (splitting of atoms) power has been a logical alternative in both fact and fiction, due to its ability to provide abundant power with high energy density, reliability, and immunity to severe environments. Bringing space fission power to a state of readiness for exploration has depended on clearing the hurdle of technology readiness demonstration. Due to the happy coincidence of heritage from prior space fission development efforts such as the Prometheus program, foresight from NASA's Exploration Mission Systems Directorate in the mid-2000's, and relative budget stability through the late 2000's, National Aeronautics and Space Administration (NASA) and Department of Energy (DOE), with their industry partners, are poised to push through to this objective. Hardware for a 12 kWe non-nuclear Fission Power System Technology Demonstration Unit is being fabricated now on a schedule that will enable a low-cost demonstration of technology readiness in the mid-2010s, with testing beginning as early as 2012. With space fission power system technology demonstrated, exploration mission planners will have the flexibility to respond to a broad variety of missions and will be able to provide abundant power so that future explorers will, in planning or crisis, have the power they need when they most need it.					
15. SUBJECT TERMS Nuclear electric power generation					
16. SECURITY CLASSIFICATION OF:			17. LIMITATION OF ABSTRACT UU	18. NUMBER OF PAGES 17	19a. NAME OF RESPONSIBLE PERSON STI Help Desk (email: help@sti.nasa.gov)
a. REPORT U	b. ABSTRACT U	c. THIS PAGE U			19b. TELEPHONE NUMBER (include area code) 443-757-5802

