

# Overview of NASA's Supersonic Cruise Efficiency – Propulsion Research

The research in Supersonic Cruise Efficiency – Propulsion (SCE-P) Technical Challenge area of NASA's Supersonics project is discussed. The research in SCE-P is being performed to enable efficient supersonic flight over land. Research elements in this area include: Advance Inlet Concepts, High Performance/Wider Operability Fan and Compressor, Advanced Nozzle Concepts, and Intelligent Sensors/Actuators. The research under each of these elements is briefly discussed.

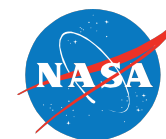

# Overview of NASA's Supersonic Cruise Efficiency – Propulsion Research

Jim DeBonis  
Associate Principal Investigator  
Supersonics Cruise Efficiency - Propulsion

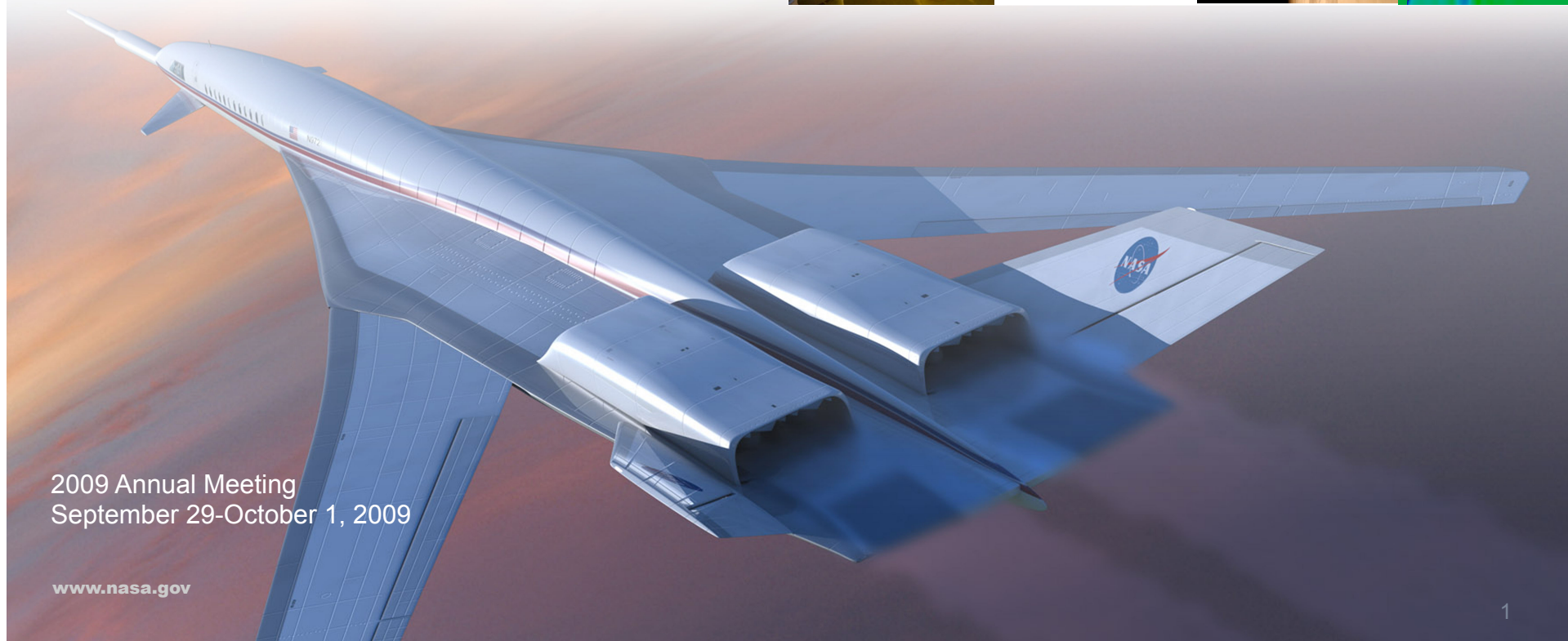
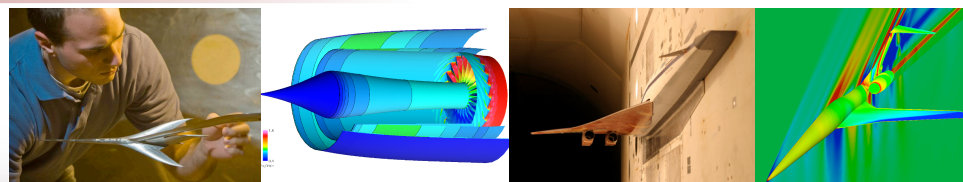

2009 Annual Meeting  
September 29-October 1, 2009

# SCE-P Motivation

---



In order to achieve economic viability, supersonic cruise civil aircraft need to achieve unprecedented levels of cruise efficiency.

To achieve high efficiency, the propulsion system must be designed and optimized as an integrated system and installed in an optimal way on the airframe.

This cruise efficiency must be preserved while

1. Meeting stringent airport noise requirements at takeoff and landing
2. Minimizing the aircraft's sonic boom signature.

# Research Elements

---



- Advanced Inlet Concepts
  - Micro-Array Flow Control
  - Assess Inlet-Fan Interactions
  - Supersonic Inlet Designs Tools
  - Inlet Bleed Modeling
  - Low Boom/High Performance Inlet Development
- High Performance/Wide Operability Fan and Compressor
- Advanced Nozzle Concepts
  - Improved Nozzle Force Measurements
  - Jet Plume Effects on Sonic Boom
  - Low Boom/Low Noise/High Performance Nozzle Development
- Intelligent Sensors/Actuators

# Inlet Flow Control – Small Scale



- Computational Fluid Dynamics
  - Reynolds Averaged Navier-Stokes
    - Initial proof of concept
    - Ramp shaping studies
  - Large-eddy simulation
    - NRA: Eric Loth, PI, University of Illinois
- Experiment
  - GRC 15cm x 15cm tunnel
  - Oblique shock boundary layer interactions
    - Micro-ramp control
    - Testing completed
  - Normal shock boundary layer interactions
    - Hybrid micro-ramp/micro-blowing control
    - Testing FY10

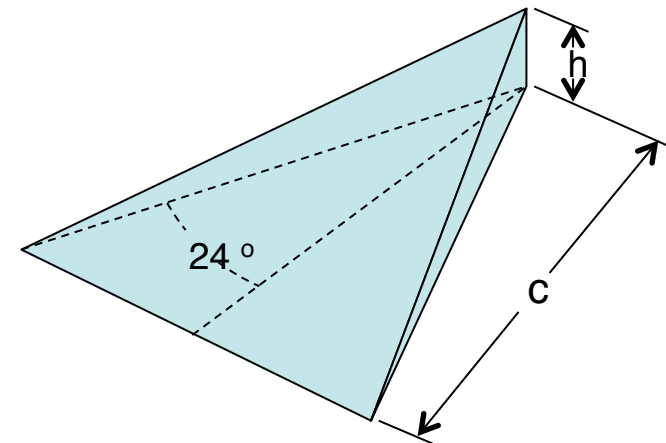

*Micro-ramp flow control device*

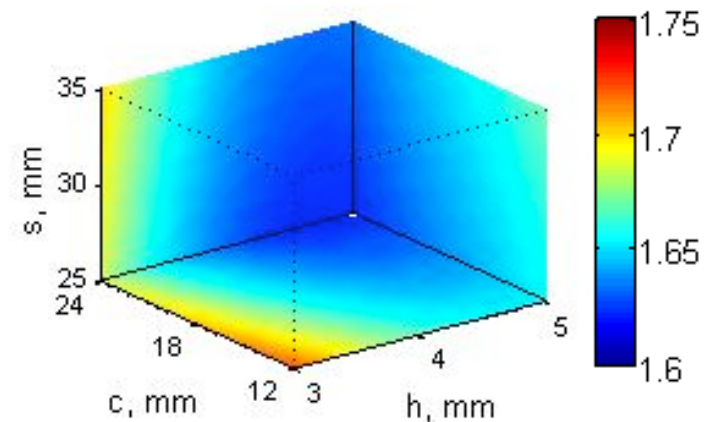

*Response Surface of Shape Factor for Control of Oblique Shock Boundary Layer Interaction*



# Inlet Flow Control - Risk Reduction

- USAF/Boeing TRICS Rig
- NRA: Jim Mace, PI, Boeing
- Direct connect facility
  - Normal shock/boundary layer interaction
  - Subsonic diffuser
- Test inlet flow control devices
- Correlate boundary layer health near the interaction with system performance

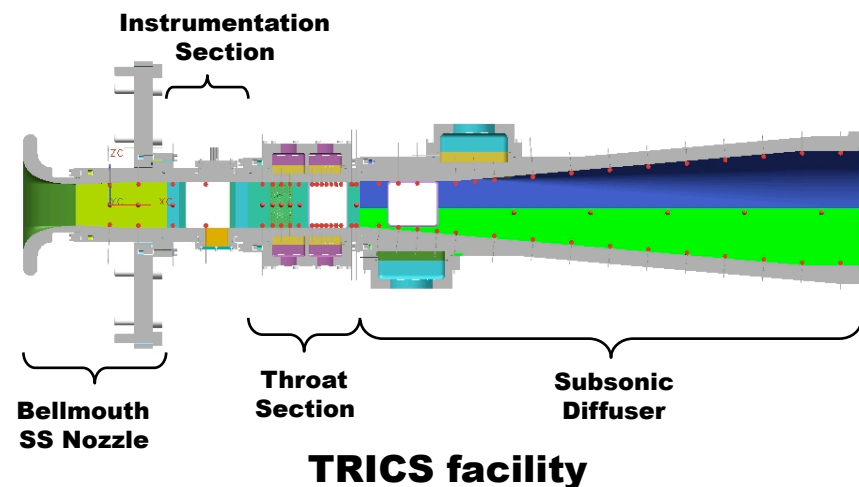

# Inlet Flow Control - Large-Scale Testing



- NASA/Techland 40/60 Inlet
  - NRA: Lois Weir, PI, Techland Research Inc.
  - Hybrid micro-ramp/micro-blowing control
    - Control to replace/minimize performance bleed
    - Stability bleed system still necessary
  - Mach 2.5
  - Mixed-compression inlet
  - 10ft. x 10ft. supersonic tunnel
  - Hardware currently being fabricated
  - Testing in FY11

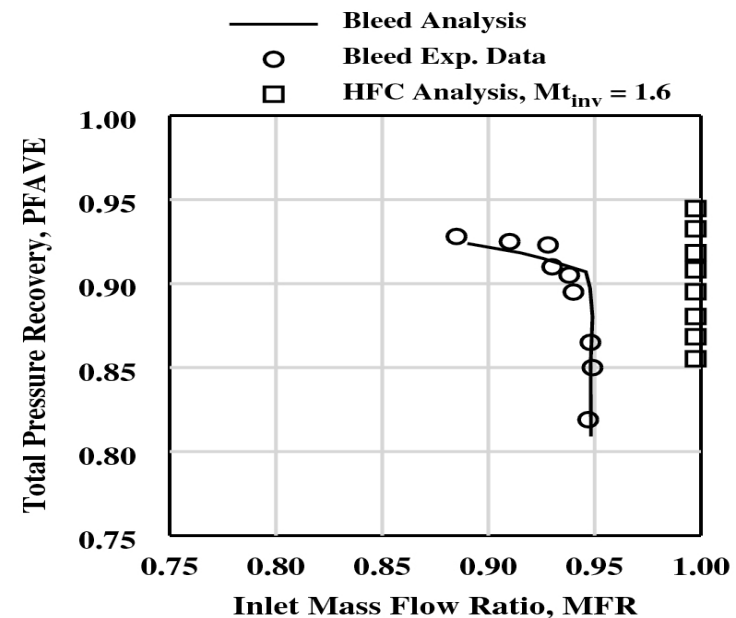
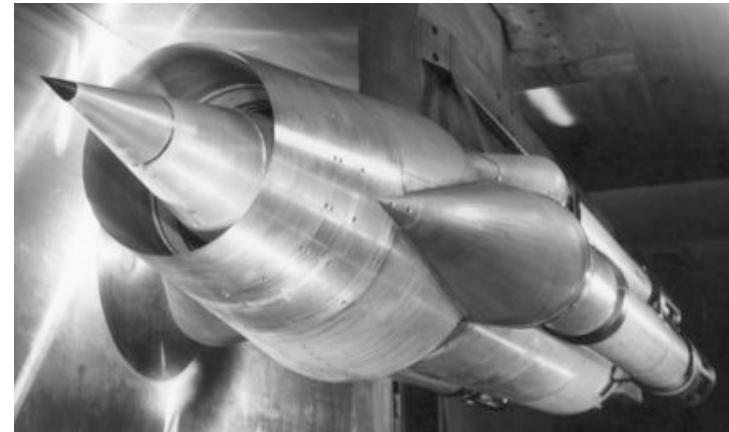

# Low-Boom Inlet Development



- Inlet design
  - Gulfstream concept
    - Mach 1.7
    - Relaxed external compression
    - Low cowl angle
  - NRA: Univ. of Illinois/Gulfstream
    - PI: Eric Loth, Univ. of Illinois
    - Single stream design
    - Micro-ramp/vortex generator flow control of centerbody boundary layer
- Large-scale test
  - GRC 8ft. x 6 ft. tunnel
  - Spring 2010

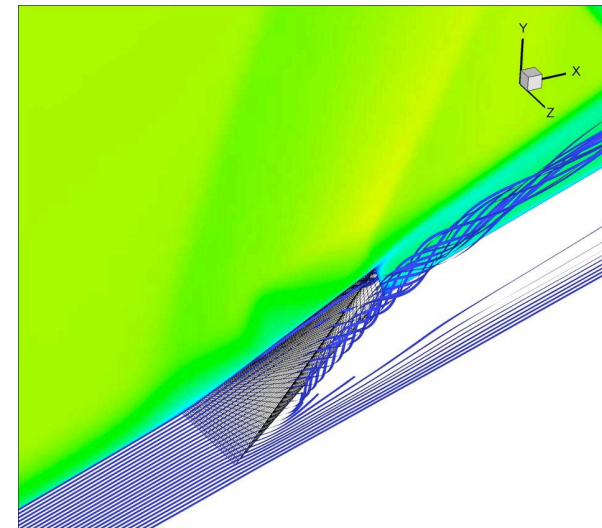
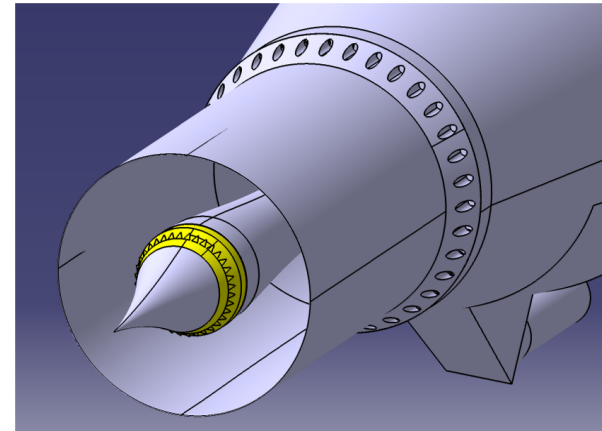

Presentation by Rod Chima  
Wednesday Morning





# Inlet Bleed Modeling

---

- Model development and implementation
  - Improvements to current state-of-the-art models
  - Implementation into the Wind-US code
  - Slater, AIAA Paper 2009-710
- Bleed hole simulations
  - NRA: A. Hamed, PI, University. of Cincinnati
  - Detailed information for model development
  - Hamed et al, AIAA Paper 2009-1260
- Fundamental experiments
  - Validate new models
  - Bleed database
  - 15cm x 15cm wind tunnel
  - Testing FY10

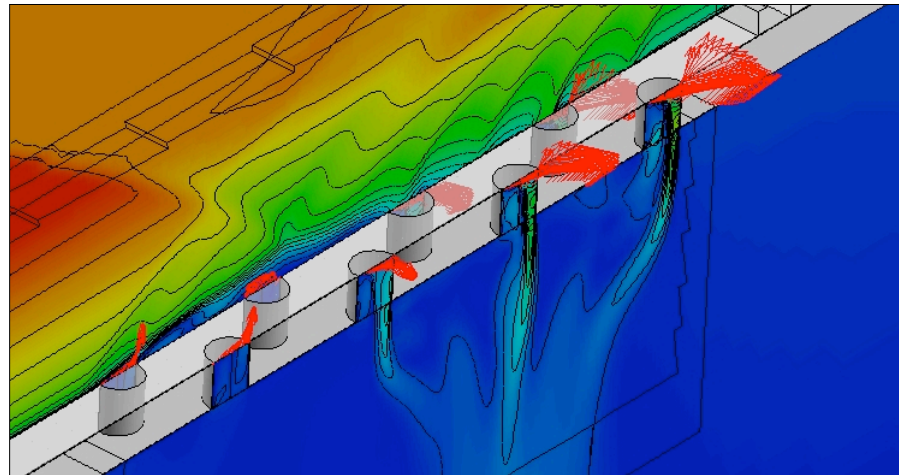

# Inlet Design Tools

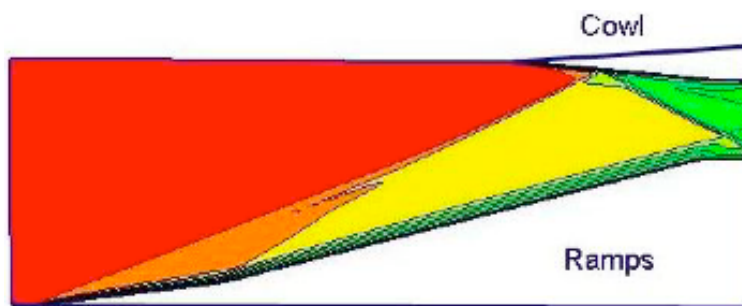
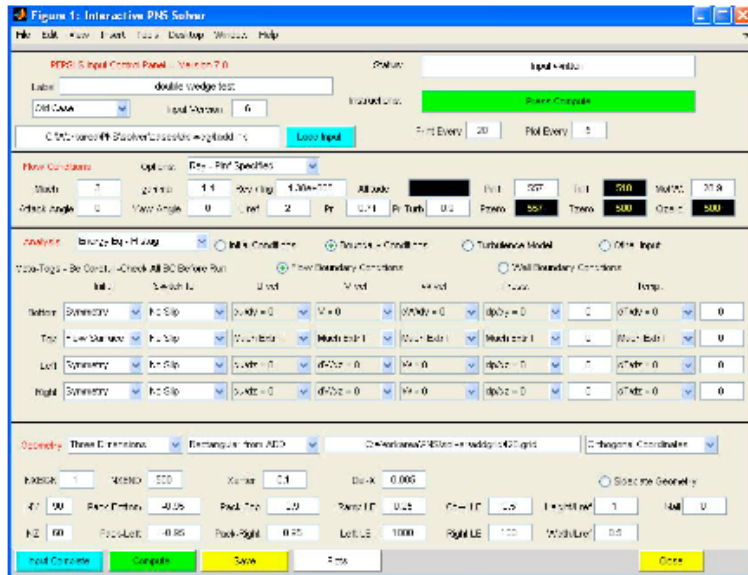

Presentation by John Slater  
Wednesday Morning

- Rehabilitation of old codes
  - PEPSI-S: Supersonic Parabolized Navier-Stokes
    - Inlets and forebodies
    - Benson et al, AIAA Paper 2009-711
  - PEPSI-G: Subsonic Parabolized Navier-Stokes
    - Diffusers and ducts
  - Inlet MOC: Method of Characteristics analysis code
- Modern Design Tool Framework
  - Will link geometry, design and analysis tools together in a modern framework
  - 3D capabilities

# Flight Test of the Channeled Centerbody Inlet

---



- Patented centerbody design allows large throat area variation through simple lightweight system
- Developed by Techland Research under a NASA SBIR
- Will be flight tested on the Dryden F-15 in FY10

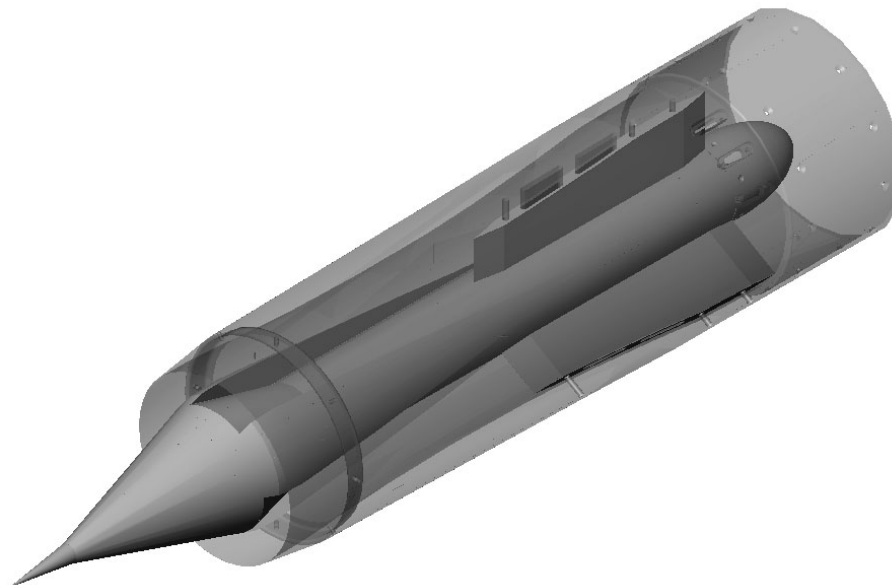

# Inlet/Fan Interactions



- Steady state tools
  - RANS based
  - Inlet and Turbomachinery codes coupled via TCP-IP based scheme
  - AVCS or Wind for the Inlet
  - SWIFT for the fan
- Unsteady analysis
  - Unsteady RANS
  - Large-eddy simulation
  - H3D code
  - Hah, AIAA Paper 2009-1061

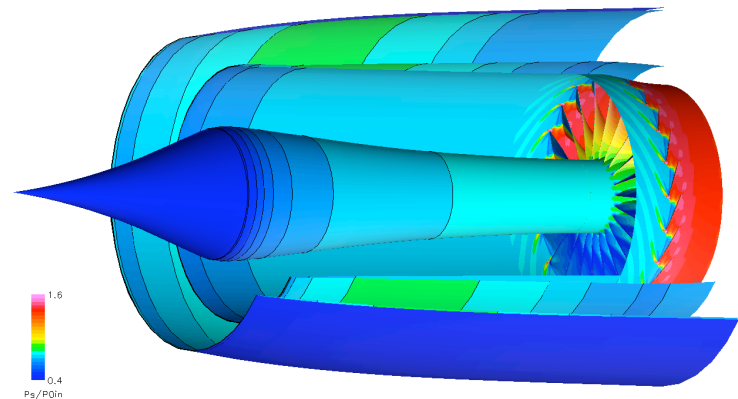

*Coupled Analysis of UIUC/Gulfstream Low-Boom Inlet – Rolls Royce Tay Fan*

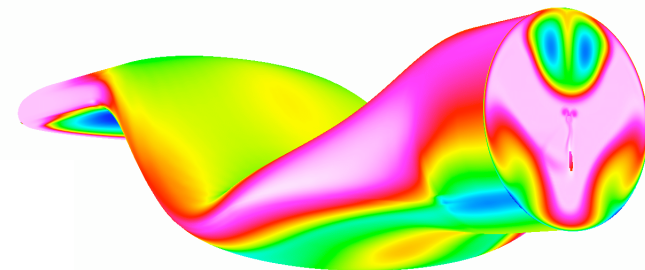

*Analysis of U.S. Air Force UAV Inlet*

Presentation by Rod Chima  
Wednesday Morning

# Improved Nozzle Force Measurements



- Upgrading force measurement in Nozzle Acoustic Test Rig (NATR)
  - Simultaneous force and noise measurements
  - Refurbish, improve and calibrate existing force balance
- 6-component balance for GRC Jet Exit Rig
  - Rig used in GRC 9'x15', 8'x6' and 10'x10' wind tunnels
  - Triumph Aerospace Sys.
  - Hardware fab. and instrumentation complete
  - Preparing for final assembly and leak check
  - Calibration in the 6 axis Automatic Balance Calibration System (ABCS) summer 2009

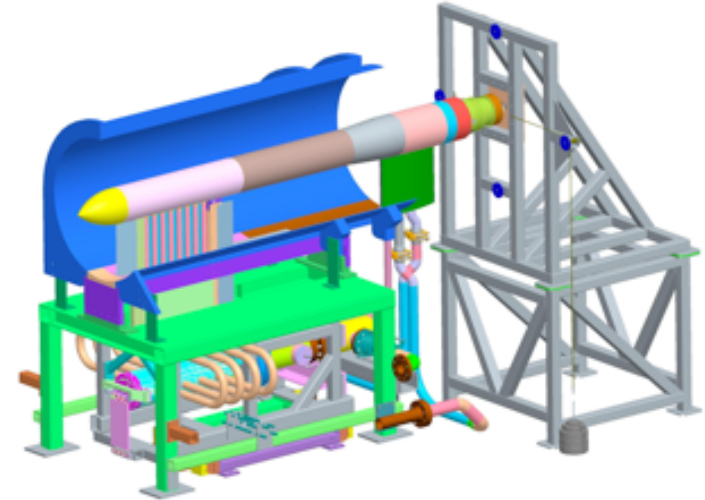

*High Flow Jet Exit Rig, Force Balance and Calibration Hardware in NASA Glenn NATR*

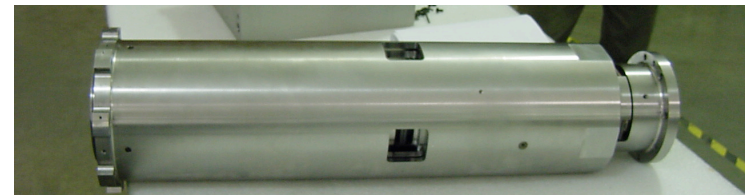

*6-Component Balance for GRC Jet Exit Rig*

# Jet Plume Effects on Sonic Boom



- Develop guidelines for nozzle shape, integration and operation for high-performance low-boom operation
- Compliments LANCETS F-15 flight test
- Analysis
  - Wind-US - CFD & PC-Boom - propagation
  - Effects of: NPR, boattail angle, stagger and spacing
  - Castner, AIAA Paper 2008-3729
- Wind tunnel testing
  - 1'x1' small scale testing
  - New jet exit rig being fabricated
  - Currently testing

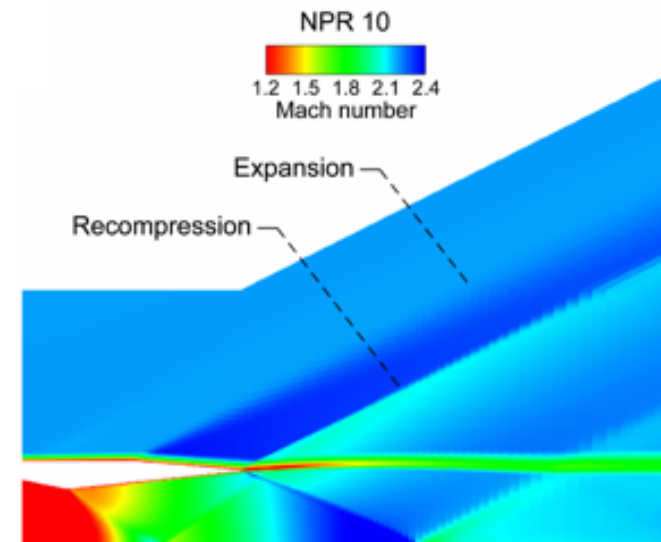
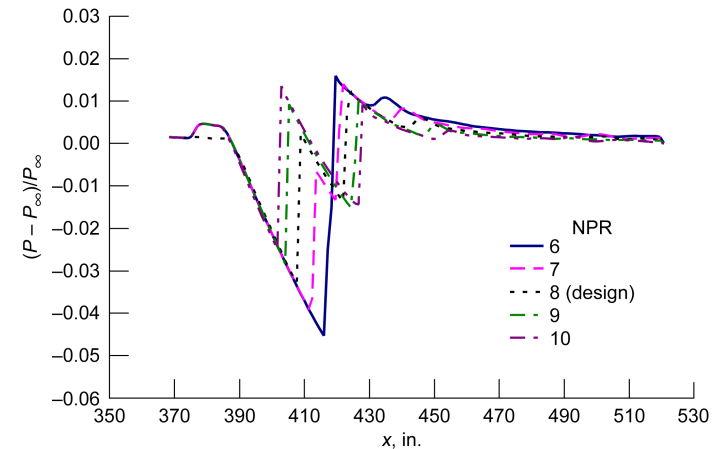



# Dynamic Flow Angularity Probe

- NRA: Alex Ned, PI, Kulite Semiconductor Products Inc.
- Inlet distortion measurements
- 0.170 diameter head w/ 5 surface mounted Kulite sensors
- Performance
  - Spatial resolution 0.052 inch minimum
  - Frequency response up to 4kHz minimum.
  - Flow angle accuracy  $0.5^\circ$  to  $1.0^\circ$  over  $\pm 35^\circ$  range
- Prototype assembly completed, ready for calibration at MIT

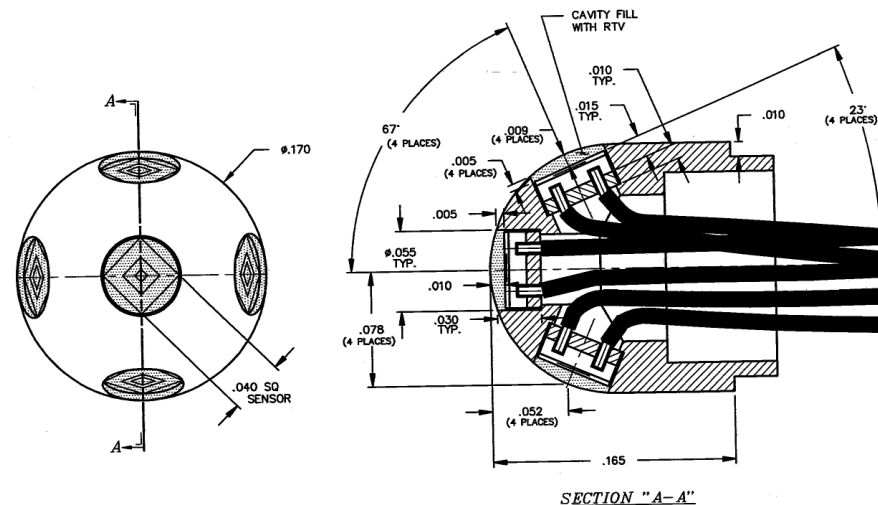



# Intelligent Sensors/Actuators



- Microwave Tip Clearance Sensor
  - Developed under the NASA SBIR and UEET Programs by Radatec, Inc.
  - High temperature,  $\sim 1200$  °C
  - Highly accurate,  $\sim 25\mu\text{m}$
  - Sensors have been used on several experiments at GRC to evaluate & demonstrate their performance.
  - Work concluded
- Flow Visualization and Optical Diagnostic Measurements
  - Investigate techniques to support supersonic inlet testing
  - Near term focus on improving Schlieren systems in the 8x6 and 10x10 wind tunnels
  - Long term goal of developing other techniques (PIV, PSP etc.)



*Microwave sensors installed on the NASA Turbofan Test Rig*

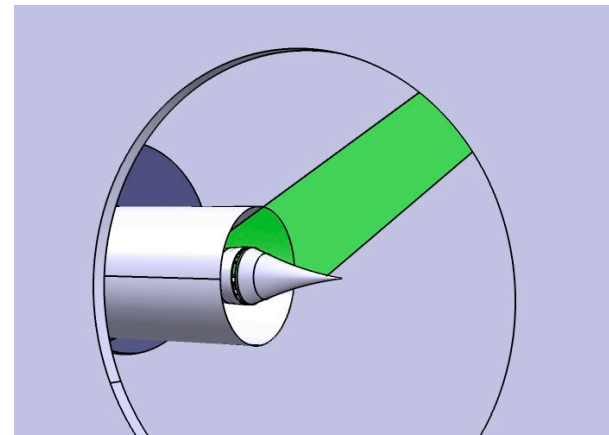

*Concept of PIV system for low-boom inlet test in NASA 8' x 6' SWT*





# Key Events

---

- Low-boom inlet test
  - NASA GRC 8' x 6' Supersonic Tunnel
  - Spring of 2010
- Improved nozzle force measurements
  - Nozzle Acoustic Test Rig
    - Simultaneous force and noise measurements
    - December 2009
  - 8' x 6' and 10' x 10' Supersonic Wind Tunnels
    - 6-component force balance for Jet Exit Rig
    - September 2010
- Large-scale demonstration of micro-array flow control
  - 40-60 inlet
  - Hybrid micro-ramp/micro-blowing control
  - 2011

