

Altair Lander Life Support: Design Analysis Cycles 4 and 5

Molly Anderson¹, Su Curley,² Henry Rotter³, and Imelda Stambaugh⁴
NASA Johnson Space Center, Houston, Texas, 77058

Evan Yagoda⁵
Jacobs Technology, Houston, Texas, 77058

Life support systems are a critical part of human exploration beyond low earth orbit. NASA's Altair Lunar Lander team is pursuing efficient solutions to the technical challenges of human spaceflight. Life support design efforts up through Design Analysis Cycle (DAC) 4 focused on finding lightweight and reliable solutions for the Sortie and Outpost missions within the Constellation Program. In DAC-4 and later follow on work, changes were made to add functionality for new requirements accepted by the Altair project, and to update the design as knowledge about certain issues or hardware matured. In DAC-5, the Altair project began to consider mission architectures outside the Constellation baseline. Selecting the optimal life support system design is very sensitive to mission duration. When the mission goals and architecture change several trade studies must be conducted to determine the appropriate design. Finally, several areas of work developed through the Altair project may be applicable to other vehicle concepts for microgravity missions. Maturing the Altair life support system related analysis, design, and requirements can provide important information for developers of a wide range of other human vehicles.

I. Introduction

THE Altair lunar lander is evolving from providing a critical part of the Constellation architecture for lunar exploration to enabling other architectures and missions beyond Low Earth Orbit (LEO). The project team is also evolving from being the Altair Project office within the Constellation Program, to being a Spacecraft Conceptual Design Office supporting architecture and concept development throughout NASA. Altair's Design Analysis Cycle 4 was conducted to add capability to the vehicle design concept to meet program requirements not originally part of the minimum functionality baseline. The next activity cycle, originally dubbed DAC-5, but then renamed the Alternative Architecture Design Analysis Cycle (AADAC), focuses on a "Lunar Orbit Rendezvous" mission where separate propulsion stages perform the Lunar Orbit Insertion (LOI) maneuver. This change in mission architecture greatly diminishes the requirements on the lander propulsion system and opens up new possibilities for the lander physical architecture. For the life support system, the top level requirements for both missions remain very similar. This paper will discuss changes made to the Altair lander in DAC-4, and the studies currently underway as part of DAC-5/AADAC.

II. Design Analysis Cycle 4

The fourth Design Analysis Cycle undertaken by the Altair project was organized to add functionality to the vehicle based on requirements accepted during the previous two Requirements Analysis Cycles (RACs). Many of the changes in the life support system were driven by the Human System Integration Requirements (HSIR) or Interface Requirements Documents (IRDs) with the Orion Crew Exploration Vehicle. It also provided an opportunity to mature some aspects of the design or to optimize systems to minimize mass.

A. Hot Water

¹ Altair Life Support Lead/Acting VE&I Lead, 2101 NASA Parkway, Houston, Texas, 77058, Mail Code EC2.

² Life Support Engineer, 2101 NASA Parkway, Houston, Texas, 77058, Mail Code EC3.

³ Altair ECLSS Architect, 2101 NASA Parkway, Houston, Texas, 77058, Mail Code C104.

Altair Life Support Lead, 2101 NASA Parkway, Houston, Texas, 77058, Mail Code EC2.

⁵ Life Support Engineer, Jacobs Technology, 2101 NASA Parkway, Houston, Texas, 77058, Mail Code JE44.

The HSIR requirement to provide hot water to the crew had been a hotly debated topic within the Altair project for several years. Existing galley systems, such as the one on the International Space Station, are not low mass assemblies. And many participants in the discussions can imagine camping trips, military operations, or household mishaps when they survived and worked without hot water. In the end, the decision to add a hot water capability was dependent on nutrition, not crew comfort. NASA's food system includes a mix of natural form and dehydrated foods. A nutritionally balanced menu requires a mix of all these foods to provide the right ratio of carbohydrate, protein, and fat based calories while providing necessary vitamins and minerals. Theoretically, a new diet might be devised to provide these from non-dehydrated foods. But the Constellation program did not include funding to develop an entirely new food system. New work was already required to pursue menu items with longer shelf life stability for lunar surface missions, which are often at least partially dehydrated.

To minimize the mass impact, the system is designed to provide sufficient hot water for each crew meal. It will not continuously produce hot water on demand. The potable water consumed in the lander is generated from fuel cells, and the product water is hot when delivered. Unfortunately, the delivery rate is much slower than is required to fill a food packet or drink bag in a reasonable amount of time. Therefore the team had to pursue a design that actively heats and maintains water temperature. In the selected design, water treated with the silver residual biocide is drawn from the potable water tank into a bellows tank with embedded heater. The heater is able to heat the water to the required temperature range in a few hours. After the hot water is used for a meal, the tank is refilled with ambient water to be heated. If the water tank was constantly refilled while being used, the hot water would be diluted, and it would either quickly drop below the required temperature range and require a high power heater, or have to be very large. This concept reduces the power consumed and tank size.

B. Air Quality Monitoring Architecture

Sensors that can measure the gases present in the spacecraft atmosphere are required for several reasons. Measuring oxygen and total pressure is necessary to allow the Pressure Control System to manage the crew environment. Measuring Carbon Dioxide and Humidity is required to control and monitor the health of the Air Revitalization System. Measuring Carbon Monoxide (CO), Hydrogen Chloride (HCl), and Hydrogen Cyanide (HCN) to detect fires. Other contaminants may need to be measured as well if they could be generated or released from another system inside the vehicle.

In DAC-4, Altair adopted a dissimilarly redundant system for air quality monitoring in the ascent module and airlock. In the ascent module, a combination of a mass spectrometry instrument and a Raman spectroscopy instrument. The mass spectrometer can measure oxygen and many other trace gases. Raman spectroscopy can differentiate N₂ from CO, which improves leak detection capability, and measure trace gases. In the unlikely event that both sensors failed, miniaturized oxygen sensors can be used by the crew to monitor cabin oxygen and determine if O₂ must be added manually through the low flow contingency valve.

In the airlock, a Tuneable Diode Laser system would be used to measure O₂ and critical trace gases. Separate O₂ measurement is required for the airlock repressurization and to detect leaks from the oxygen systems used to recharge the PLSSs. Separate fire detection is necessary because ventilation between the cabin and airlock will be minimal because the hatch is usually closed to keep lunar dust from migrating into the cabin. The TDL technology can operate in very challenging industrial environments and maintain accuracy at multiple pressures. It was selected because it would still operate well with significant lunar regolith or dust present in the atmosphere and during airlock repressurization.

C. O₂ and N₂ Storage for Contingencies, Global Access, and Portable Life Support System Recharge

Several changes were made during DAC-4 that changed the quantity of oxygen or nitrogen required. The quantities of oxygen and nitrogen on the descent stage were modified, and the optimal location of each was reassessed.

First, in RAC-1, the team accepted the requirement to return the crew safely in the event that the Orion vehicle had become unable to hold pressure while the crew was on the lunar surface. This scenario has the longest timeline of any abort or contingency after ascent considered. It requires that the crew ascend and dock with the Orion CEV, perform an EVA to retrieve the Launch, Entry, and Abort (LEA) configuration suits from the CEV, repressurize the lander ascent module to change from the surface suit to LEA suit, and then perform another EVA to return to the CEV so they can return to Earth.

Secondly, the Altair project accepted the requirement to provide consumables during a several day long loiter in lunar orbit. Using this loiter to access all possible landing sites on the lunar surface was considered more efficient than adding propulsion to change the vehicle orbit. The ascent module and descent module are still connected in this phase of the mission, so the consumables and tanks can be added to the descent module.

The third change that impacted the gas storage design was due to new understanding of Altair-EVA operations scenarios, and new technology understanding. In the Exploration Life Support project, a three stage mechanical compressor to pressurize oxygen successfully completed initial testing. The compressor was lower mass and used less power than the hybrid system of solid state adsorption and a single stage mechanical compressor. It also promised to be able to provide gas at a much higher flow rate.

In the EVA project, tank sizes and functionality for the PLSS were better defined. The primary oxygen tank for the PLSS is large enough to hold what is required for crew metabolism and leakage during the EVA. However, the suit is designed to be purged with a similar amount of high pressure gas, presumably also from that tank, right before EVA. Additionally, EVA began requesting that the airlock be repressurized within two minutes. The oxygen used to repressurize the vehicle will be scavenged from the ullage of descent stage propellant tanks. However, it is not feasible to deliver it in two minutes.

The new compressor capability allowed the life support team to devise a schedule that used a single tank to scavenge gas over time and provide for all EVA needs. Spent PLSSs are returned from EVA, and the compressor scavenges O₂ from the propellant tanks and fills the life support system O₂ accumulator with high pressure oxygen. Before crew sleep, the PLSS tanks are recharged from that O₂ accumulator to 21000 kPa (3000 psia). The compressor fills the oxygen accumulator again overnight. For the next day's EVA activity, after the crew uses oxygen from the PLSS tanks to purge the EVA suits, the accumulator is used to quickly recharge the PLSS tanks. In order to fully refill the PLSS tanks, the accumulator must remain at pressures slightly above to 21000 kPa (3000 psia). Therefore, it has sufficient oxygen left to provide emergency O₂ to a returning crew member at all times during the EVA. After the EVA, the oxygen left in the accumulator and any compressed during the EVA can be used to repressurize the airlock. This tank could also provide high pressure O₂ to the cabin for a feed the leak contingency. There would not be sufficient O₂ to repressurize the airlock, but that's not necessary if the ascent module is leaking and cannot hold pressure.

In order to optimize the vehicle mass and compare options, a consistent and scalable method for quickly estimating tank masses is required. For the initial baseline designs, a mass estimate for gas tanks could be generated by finding an existing flown tank design of approximately the right volume. However, height to width ratios, materials of construction, attachment points, and other design issues can vary significantly from design to design, sometimes resulting in cases where a smaller tank weighs more than one that holds more volume. The Altair life support team collected data from 3 manufacturers of composite overwrap pressure vessels (COPVs) including 68 different tank designs. A correlation was developed relating tank volume and burst pressure to the tank mass, in order to be able to estimate and scale tanks when performing the configuration and optimization studies.

D. Air Revitalization System (ARS) Pressure Drop Optimization and Suit Interface

The LDAC-4 vehicle design uses the ascent module to support suited crewmembers during descent and ascent, and to provide shirt-sleeve habitation during the surface mission. A single air revitalization system is used for both these phases, and the power consumed by the ARS fans is the largest power consumer in the life support system. The ARS fan is difficult to make efficient because it must provide low flow rates through a high pressure drop system when the crew is suited and using umbilicals, and provide more flow through a lower pressure drop system when providing airflow directly to the cabin. Altair had originally intended to use the same interface for flow inlet and outlet in both cases. The vehicle would have an Umbilical Interface Panel (UIP) that would mate to the umbilical hoses the EVA system uses to deliver water, air, power, and data connectivity to the suits. When the umbilicals were not in use, another panel could be mounted that would close the water ports, but allow adjustable air ventilation to the cabin. This same concept was to be used in the CEV, so the crew would simply remove the panels from the CEV and bring them into the lander.

During the LDAC-4 period, the CEV changed their assumed design. Using the removable panels means that the pressure drop of flowing through the UIP is always present. The CEV chose a design where a selector valve can pull flow from either vents to the cabin or the UIP, and then direct it to parallel paths with some flow passing through ARS fans and amine swing beds for CO₂ and H₂O removal, and most of the flow passing through a larger fan and heat exchanger. Without the panels provided from the CEV, Altair examined several possible options. The design selected for the lander also uses a selector valve to draw flow either through cabin vents or through the UIPs. However, the flow only passes through the ARS fans and hardware. The high flow rate cabin fan is still left separate from the ARS, so that it can remove lunar dust from the cabin air during ascent when the crew is suited and using the ARS through umbilical connections.

The team also explored a wide range of ways to save power and mass with other design changes. Some trace contaminant control functions might be able to be moved the cabin fan flow path. To optimize flow and pressure drop in post-ascent contingencies, the system might accept higher humidity in the cabin by minimizing flow rate, or

might flow through both amine swing beds, even if overdrying were an issue. The EVA umbilical concept currently assumes two long umbilicals and two short umbilicals with restrictors to balance flow to each EVA suit, but those could be reconsidered. Any reduction in the flow rate required to the suit would also help minimize power consumption, but those design decisions must be made within the EVA project, not Altair.

Not all of these analyses and recommendations were completed in time for the DAC-4 vehicle closure. But they were accepted by the life support system and vehicle team to be implemented in the next design and added to the life support system schematic.

E. DAC-4 Conclusion

The vehicle concept after DAC-4, shown in Figure 1, provided a reoptimized life support system design to support four crew members during suited ascent and descent, during surface stay habitation and some microgravity habitation functions, and enabled them to perform EVAs to explore the lunar surface.

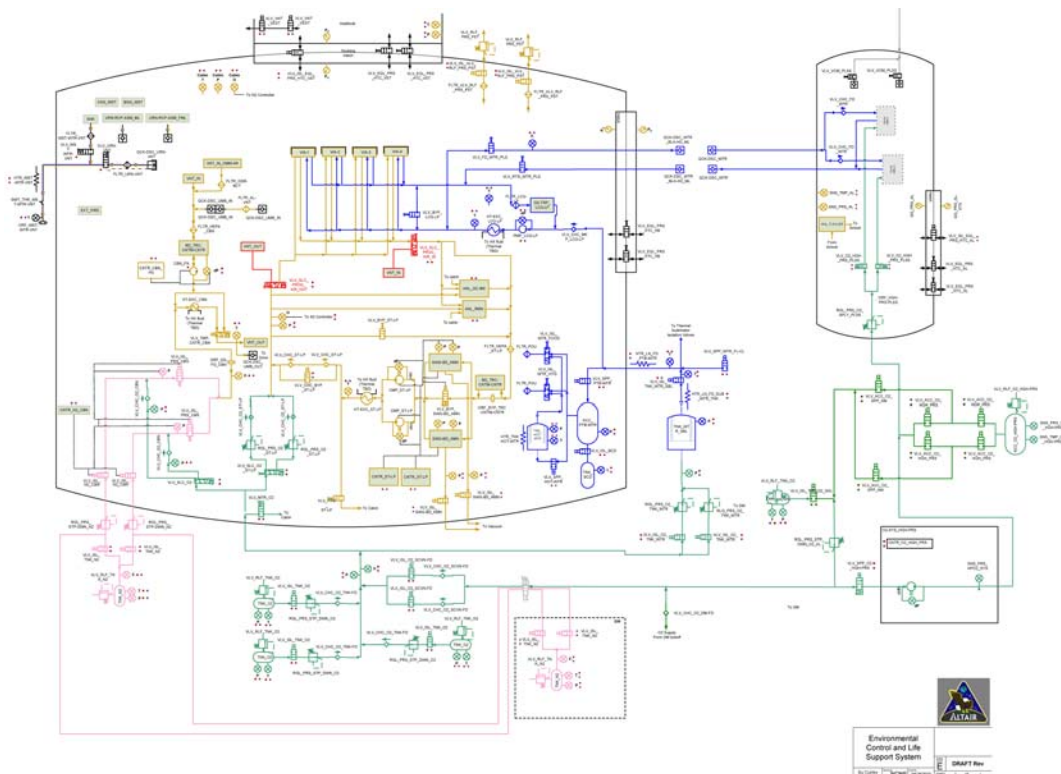

Figure 1: Altair DAC-4+ Life Support System Schematic

III. Design Analysis Cycle 5/Alternative Architecture Design Analysis Cycle

After LDAC-4, the Altair project team faced a changing environment inside NASA with uncertainty about the future of the Constellation Program and what would follow. Rather than an “LDAC-5” to further evolve the Constellation architecture lander, the team turned to a new Lunar Orbit Rendezvous architecture. In this concept the lander and CEV capsule would launch on the same type of rocket, and the increased lift capability with the CEV launch would allow each to have individual stages to perform the Lunar Orbit Insertion. With such a radical change, the team returned to the basic questions that drive vehicle design. Many propellants and new tank configurations need to be compared for the new requirements. Since LOI loads don’t have to pass through the lander to the CEV, new configurations of the ascent/descent, habitation, and EVA airlock functions might be used. Also, this design expects that the lander will have a long loiter period before descent, changing propellant and reactant management. While the life support system requirements are not likely to change, such major changes in the other vehicle systems would likely make different configurations or technologies the optimal choice.

A. Descent Module Changes

The LDAC-4 lander design assumes that unused oxygen in the descent stage propellant tanks can be scavenged for use in the life support system and to supply fuel cells to generate power. If the propellant system chosen does not include oxygen (such as with a hypergol system), then the life support system will clearly have to supply its own oxygen. But even in a system with methane or hydrogen reacting with oxygen, the removal of the LOI requirement may reduce the tank size so much that the ullage oxygen is not enough to meet life support system needs. The long vehicle loiter increases the overall demand on the power system to the point where a solar based system is likely to provide much of the vehicle power. Thus, there is unlikely to be water produced by fuel cells, and the life support system will need to provide stored water instead. These changes would increase the mass of the life support system, but still may be the optimal vehicle level design choice.

B. Ascent Module, Habitation, and Airlock Changes

Vehicle configuration work is ongoing on the configuration of the pressurized volumes to perform the ascent/descent, habitation, and EVA support functions. A truly minimal ascent module with habitation and vehicle support functions would reduce vehicle mass. However, it may need to be set off-center on the descent module in order to fit the habitation and EVA support functions on the same platform, and this may or may not be feasible. Creating a habitat with a separate airlock volume would add significant mass to the descent stage, but the use of suitports may be feasible in a case where there is still a separate AM volume to escape to in the event of a leak. The life support system may return to an LDAC-1 type configuration with a short duration air revitalization system to support suits in the ascent module, and a shirt-sleeve environment in the habitation module.

C. DAC-5/AADAC Conclusion

Work is ongoing in 2011 to redesign and reoptimize the design of a lunar lander for a new architecture. The life support system is rarely the driver for vehicle level configuration choices, and the team has identified key areas where life support system changes may be driven by vehicle changes.

IV. Contributions to Other Projects

As the Altair project team transitions to become more flexible as the Spacecraft Conceptual Design Office (SCDO), it may participate or lead efforts on other vehicles as well. The SCDO team is already providing support to the Multi-Mission Space Exploration Vehicle (derived from NASA's pressurized lunar rover concepts) to organize operations concepts. The team is also beginning to take on a design effort on a Deep Space Habitat that may be part of several NASA and international team architecture concepts. The skills, capabilities, and team connections developed throughout the Altair work will be useful as NASA examines a broad range of new architectures and destinations.

V. Conclusion

While NASA is in a period of change transitioning from the Constellation Program to other endeavours, the Altair life support system team is continuing work that will enable future human exploration of space and planetary destinations.

References

¹Anderson, M., Curley, S., Stambaugh, I., and Rotter, H., "Altair Lander Life Support: Design Analysis Cycles 1, 2, and 3," *International Conference on Environmental Systems*, SAE, Savannah, Ga., 2009.

²Anderson, M., Curley, S., Rotter, H., and Yagoda, E., "Altair Lander Life Support: Requirements Analysis Cycles 1, and 2," *International Conference on Environmental Systems*, AIAA, Barcelona, Spain, 2010.

³Mariella, R. "Sensor Systems for the Altair Lunar Lander: No Net Is Perfect – Make the Holes as Small as You Can Afford," LLNL-TR-421882, Lawrence Livermore National Laboratories, September, 2010.

Acronyms

ACDC	Altair Conceptual Design Contract
AM	ascent module
CARD	Constellation Architecture Requirements Document
CDR	Critical Design Review
CEV	crew exploration vehicle
CO	carbon monoxide

CO ₂	carbon dioxide
DAC	Design Analysis Cycle
EVA	extravehicular activity
HCl	hydrogen chloride
HCN	hydrogen cyanide
HEPA	high-efficiency particulate air
HSIG	Human-Systems Integration Group
HSIR	Human-Systems Integration Requirements
IRD	Interface Requirements Document
ISS	International Space Station
KDR	key driving requirement
LCG	liquid cooling garment
LSS	Lunar Surface System
MMOD	micrometeoroid and orbital debris
N ₂	nitrogen
O ₂	oxygen
PDR	Preliminary Design Review
PEPC	Portable Equipment, Payloads, and Cargo
RAC	Requirements Analysis Cycle
SRD	System Requirements Document
SRR	System Requirements Review