

NASA/TM-2011-217068
NESC-RP-04-092

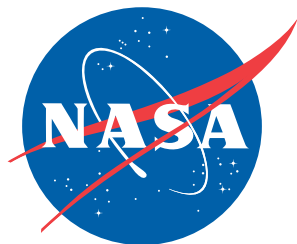

Performance Characterization of Loctite[®] 242 and 271 Liquid Locking Compounds (LLCs) as a Secondary Locking Feature for International Space Station (ISS) Fasteners

*Michael J. Dube
Goddard Space Flight Center, Greenbelt, Maryland*

*Wayne R. Gamwell
Marshall Space Flight Center, Huntsville, Alabama*

NASA STI Program . . . in Profile

Since its founding, NASA has been dedicated to the advancement of aeronautics and space science. The NASA scientific and technical information (STI) program plays a key part in helping NASA maintain this important role.

The NASA STI program operates under the auspices of the Agency Chief Information Officer. It collects, organizes, provides for archiving, and disseminates NASA's STI. The NASA STI program provides access to the NASA Aeronautics and Space Database and its public interface, the NASA Technical Report Server, thus providing one of the largest collections of aeronautical and space science STI in the world. Results are published in both non-NASA channels and by NASA in the NASA STI Report Series, which includes the following report types:

- **TECHNICAL PUBLICATION.** Reports of completed research or a major significant phase of research that present the results of NASA programs and include extensive data or theoretical analysis. Includes compilations of significant scientific and technical data and information deemed to be of continuing reference value. NASA counterpart of peer-reviewed formal professional papers, but having less stringent limitations on manuscript length and extent of graphic presentations.
- **TECHNICAL MEMORANDUM.** Scientific and technical findings that are preliminary or of specialized interest, e.g., quick release reports, working papers, and bibliographies that contain minimal annotation. Does not contain extensive analysis.
- **CONTRACTOR REPORT.** Scientific and technical findings by NASA-sponsored contractors and grantees.
- **CONFERENCE PUBLICATION.** Collected papers from scientific and technical conferences, symposia, seminars, or other meetings sponsored or co-sponsored by NASA.
- **SPECIAL PUBLICATION.** Scientific, technical, or historical information from NASA programs, projects, and missions, often concerned with subjects having substantial public interest.
- **TECHNICAL TRANSLATION.** English-language translations of foreign scientific and technical material pertinent to NASA's mission.

Specialized services also include creating custom thesauri, building customized databases, and organizing and publishing research results.

For more information about the NASA STI program, see the following:

- Access the NASA STI program home page at <http://www.sti.nasa.gov>
- E-mail your question via the Internet to help@sti.nasa.gov
- Fax your question to the NASA STI Help Desk at 443-757-5803
- Phone the NASA STI Help Desk at 443-757-5802
- Write to:
NASA STI Help Desk
NASA Center for AeroSpace Information
7115 Standard Drive
Hanover, MD 21076-1320

NASA/TM-2011-217068
NESC-RP-04-092

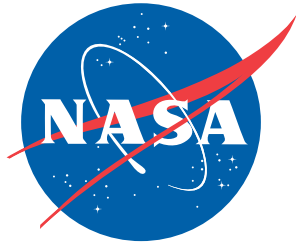

Performance Characterization of Loctite[®] 242 and 271 Liquid Locking Compounds (LLCs) as a Secondary Locking Feature for International Space Station (ISS) Fasteners

*Michael J. Dube
Goddard Space Flight Center, Greenbelt, Maryland*

*Wayne R. Gamwell
Marshall Space Flight Center, Huntsville, Alabama*

National Aeronautics and
Space Administration

Langley Research Center
Hampton, Virginia 23681-2199

March 2011

The use of trademarks or names of manufacturers in the report is for accurate reporting and does not constitute an official endorsement, either expressed or implied, of such products or manufacturers by the National Aeronautics and Space Administration.

Available from:

NASA Center for AeroSpace Information
7115 Standard Drive
Hanover, MD 21076-1320
443-757-5802

	NASA Engineering and Safety Center Technical Assessment Report	Document #: NESC-RP- 04-092	Version: 1.0
Title: Evaluate the Performance of Loctite® as a Secondary Locking Feature for ISS Fasteners		Page #: 1 of 205	

**Performance Characterization of Loctite® 242 and 271 Liquid
Locking Compounds (LLCs) as a Secondary Locking Feature for
International Space Station (ISS) Fasteners**

December 2, 2010

	NASA Engineering and Safety Center Technical Assessment Report	Document #:	Version:
		NESC-RP-04-092	1.0
Title: Evaluate the Performance of Loctite® as a Secondary Locking Feature for ISS Fasteners		Page #: 2 of 205	

Report Approval and Revision History

NOTE: This document was approved at the December 2, 2010, NRB. This document was submitted to the NESC Director on January 24, 2011, for configuration control.

Approved Version:	<i>Original Signature on File</i>	1/26/11
1.0	NESC Director	Date

Revision	Description of Revision	Author	Effective Date
1.0	Initial Release	Dr. Wayne R. Gamwell, Primary Author, MSFC Dr. Michael Dube, Assessment Lead, GSFC	12/02/10

	NASA Engineering and Safety Center Technical Assessment Report	Document #:	Version:
		NESC-RP-04-092	1.0
Title:			Page #:
Evaluate the Performance of Loctite® as a Secondary Locking Feature for ISS Fasteners			3 of 205

Table of Contents

Volume I: Technical Report

1.0	Notification and Authorization	6
2.0	Signature Page	7
3.0	Team List	8
4.0	Executive Summary	9
5.0	Assessment Plan	11
6.0	Problem Description and Proposed Solutions	12
7.0	Data Analysis	12
7.1	Establishment of Relevant Loctite® 242 and 271 Sensitivity	12
7.1.1	Parameters Effecting Cure (Design, Process, Environmental)	12
7.1.2	ISS Specific “Typical” Fastener and Process Configurations.....	14
7.1.3	Establishment of Loctite® Relevant Post-Cure Environment Considerations (Humidity, Atomic Oxygen, Thermal, Vibration, etc.)	15
7.1.3.1	Questions/Discussions with Henkel Loctite®	16
7.2	Phase Zero Testing.....	16
7.2.1	Test Instructions.....	20
7.2.2	Test Results	20
7.2.3	Discussion	21
7.2.4	Conclusions.....	22
7.3	Phase I Sensitivity Testing.....	22
7.4	Demonstrating Loctite® 242 Cure is not a Function of Preload.....	25
7.5	Phase I(a) Zero Percent Preload Sensitivity Testing.....	27
7.5.1	Effect of Cure Time	27
7.5.2	Effect of Contaminants	28
7.5.3	Effect of Activator	29
7.5.4	Effect of Thread Class on Tapped Hole.....	30
7.5.5	Application Method Sensitivity Study.....	31
7.5.6	Effect of Humidity on Cure	32
7.5.7	Overall Conclusions for Zero Percent Preload Sensitivity Testing	33
7.6	Coefficient of Thermal Expansion (CTE) Effects of Fastener Mechanical Loading with Dissimilar Materials	34
7.7	Phase II Environmental Testing.....	35
7.7.1	NASM 1312-7 Vibration Testing	35
7.7.1.1	NASM 1312-7 Vibration Test Results.....	37
7.7.2	Thermal/Vacuum Soak Testing (Hot and Cold)	38
7.7.2.1	Background.....	38
7.7.2.2	Results	39
7.7.3	Junker Testing.....	44



**NASA Engineering and Safety Center
Technical Assessment Report**

Document #:
**NESC-RP-
04-092**

Version:
1.0

Title:

**Evaluate the Performance of Loctite® as a Secondary
Locking Feature for ISS Fasteners**

Page #:
4 of 205

7.7.4	Thermal/Vacuum Cyclic Testing.....	45
7.8	Human Factors review of Application Process for LLCs in ISS Hardware.....	47
7.9	Loctite® Application Process Comparison.....	48
7.10	Literature Review.....	48
7.11	Questions/Discussions with Henkel Loctite®	48
8.0	Observations, Findings, and NESC Recommendations	49
8.1	Observations	49
8.2	Findings	49
8.3	NESC Recommendations.....	50
9.0	Alternate Viewpoints	51
10.0	Other Deliverables	51
11.0	Lessons Learned.....	51
12.0	Definition of Terms.....	52
13.0	Acronyms List	53
14.0	References.....	54

List of Figures

Figure 7.2-1.	Vibration Test Fixture.....	17
Figure 7.2-2.	Vibration Fixture Pin	18
Figure 7.2-3.	Vibration Fixture Spacer.....	18
Figure 7.2-4.	Vibration Fixture Washer	19
Figure 7.2-5.	Vibration Fixture, Helicoil® Test Block	19
Figure 7.3-1.	ANOVA on Phase I Breakloose Torque (100 percent initial torque on 0.25 inch fasteners).....	24
Figure 7.3-2.	Scatter Plot for Breakloose Torque versus Installation Torque	25
Figure 7.5-1.	Breakaway Torque versus cure time for Loctite® 242.....	28
Figure 7.5-2.	Effect of Contaminants on Breakaway Torque.....	29
Figure 7.5-3.	Effect of Activator use on Breakaway Torque.....	30
Figure 7.5-4.	Effect of Thread Class on Breakaway Torques	31
Figure 7.5-5.	Effect of Application Method	32
Figure 7.5-6.	Effect of Humidity	33
Figure 7.7-1.	Simulated Joint	38
Figure 7.7-2a.	ANOVA on Breakloose Torque versus Exposure Time (200 °F hot case).....	41
Figure 7.7-2b.	ANOVA on Breakaway Torque versus Exposure Time (-140 °F cold case)	42
Figure 7.7-2c.	ANOVA on Breakloose Torque versus Exposure Time (72 °F ambient case).....	42
Figure 7.7-3.	ANOVA on Breakaway Torque versus Temperature	43
Figure 7.7-4a.	Dotplot of Torque versus Test Series.....	43
Figure 7.7-4b.	Dotplot of Torque versus Exposure Temperature.....	44
Figure 7.7-5.	Thermal Cycle Profile.....	46
Figure 7.7-6.	Test Article Removal Schedule	46



**NASA Engineering and Safety Center
Technical Assessment Report**

Document #:
**NESC-RP-
04-092**

Version:
1.0

Title:

**Evaluate the Performance of Loctite® as a Secondary
Locking Feature for ISS Fasteners**

Page #:
5 of 205

List of Tables

Table 7.1-1	Parameters during Cure	12
Table 7.2-1.	Phase Zero Vibration Test Matrix.....	17
Table 7.2-2.	Phase Zero Vibration Test Results (A1-A15 w/ Loctite® 242; N1-N10 w/ Braycote® 601 lubricant).....	21
Table 7.3-1.	Fastener configurations for Phase I Breakloose Torque Testing	23
Table 7.3-2.	Phase I Sensitivity Test Matrix	23
Table 7.4-1.	Zero Load Wedge Fixture Test Details.....	26
Table 7.4-2.	Zero Load Wedge Fixture Test Results	26
Table 7.4-3.	Two-Factor ANOVA on Zero Load Wedge Fixture Test Results (Preload and Hole Type).....	27
Table 7.4-4.	Two-Factor ANOVA on Zero Load Wedge Fixture Test Results (Cure Environment and Hole Type)	27
Table 7.7-1.	NASM 1312-7 Test Matrix.....	36
Table 7.7-2.	NASM 1312-7 0.250-28 Vibration Testing Performance.....	37
Table 7.7-3.	Simulated Joint Test Matrix and Loading Conditions	39
Table 7.7-4.	Ambient, Hot and Cold Plate Removal Times in Hours.....	39
Table 7.7-5.	Breakloose and Running Torque Results for Thermal Vacuum Cyclic Testing of Preloaded Fasteners plus Loctite® with aluminum and Stainless Steel Cylinders.....	47

Volume II: Appendices

Appendix A.	Space Flight Environments for ISS.....	60
Appendix B.	Question and Answer meeting with Loctite® Representative.....	62
Appendix C.	Evaluation of Anaerobic Locking Compounds, Tensile Testing, Torque Tension Testing, and Breakloose and Running Torque Testing.....	69
Appendix D.	CTE Effects of Fastener Mechanical Loads	81
Appendix E.	NASM1312-7 Vibration Testing Test Plan	82
Appendix F.	Comparison of Secondary Locking Features for Threaded Inserts, July 2007	105
Appendix G.	Thermal V-acuum Testing and Results.....	147
Appendix H.	Human Factors Review of Application Process for Liquid Locking Compounds (LLC) in ISS Hardware.....	173
Appendix I.	Loctite® Application Process Comparison.....	179
Appendix J.	Literature Review of the Self-Locking of Threaded Fasteners.....	184

	NASA Engineering and Safety Center Technical Assessment Report	Document #: NESC-RP-04-092	Version: 1.0
Title: Evaluate the Performance of Loctite® as a Secondary Locking Feature for ISS Fasteners		Page #: 6 of 205	

1.0 Notification and Authorization

The International Space Station (ISS) Program Manager requested the NASA Engineering and Safety Center (NESC) to help understand and quantify sensitivities of Loctite® 242 and 271 liquid locking compounds (LLCs) being used as a secondary locking feature on ISS fasteners. The ISS Program wanted to determine under what conditions Loctite® 242 and 271 works reliably. The Out of Board Summary was approved by the NESC Review Board (NRB) on December 14, 2004. The assessment plan was approved by the NRB on April 21, 2004.

Mr. John McManamen was initially assigned to lead this assessment. Dr. Michael Dube assumed the role of assessment lead for this task with the transition of Mr. McManamen from the NASA Technical Fellow for Mechanical Systems to the Space Shuttle Program Chief Engineer. The final report was presented for approval to the NRB on December 2, 2010.

	NASA Engineering and Safety Center Technical Assessment Report	Document #:	Version:
		NESC-RP-04-092	1.0
Title: Evaluate the Performance of Loctite® as a Secondary Locking Feature for ISS Fasteners			Page #: 8 of 205

3.0 Team List

Name	Discipline	Organization
Core Team		
Michael Dube	NESC Lead	GSFC
Phil Hall	Initial Team Lead	MSFC
Elvin Ahl	Mechanical Systems TDT	LaRC
Carlton Foster	Mechanical Systems TDT	MSFC
Brian Jensen	Materials TDT	LaRC
Tina Beard	Human Factors TDT	ARC
Kenny Elliott	Systems Integration	LaRC
Wayne Gamwell	Materials Engineer	MSFC
Ed Hemminger	Structural Test and Analysis	GSFC
Andrew Hodge	Materials Engineer	MSFC
Carmine Mattiello	Structural Dynamics	GSFC
Kara Slade	Structural Dynamics	LaRC
Jim Taylor	Human Factors	ARC
Amanda Cutright	Aerospace Engineer	LaRC
Roy Savage	MTSO Program Analyst	LaRC
Dan Hess	Mechanical Engineering	University of South Florida
Consultants		
Rajib Dasgupta	Materials Engineer	JSC
Al Parrish	ISS Chief Engineer (former)	JSC
Chris Hansen	ISS Chief Engineer (current)	JSC
Administrative Support		
Terri Derby	Project Coordinator	LaRC/ATK
Linda Burgess	Planning and Control Analyst	LaRC/ATK
Erin Moran	Technical Writer	LaRC/ATK

	NASA Engineering and Safety Center Technical Assessment Report	Document #: NESC-RP-04-092	Version: 1.0
Title: Evaluate the Performance of Loctite® as a Secondary Locking Feature for ISS Fasteners		Page #: 9 of 205	

4.0 Executive Summary

Several International Space Station (ISS) hardware components use Loctite® (and other polymer based liquid locking compounds (LLCs)) as a means of meeting the secondary (redundant) locking feature requirement for fasteners. The primary locking method is the fastener preload, with the application of the Loctite® compound which when cured is intended to resist preload reduction. The reliability of these compounds has been questioned due to a number of failures during ground testing. Failures have been related to a lack of proper procedures being followed for Loctite® application, leading to incomplete cure. The NASA Johnson Space Center (JSC) engineering community implemented a policy restricting the use of Loctite® as a secondary locking feature especially in safety critical applications due to this perceived unreliability.

The ISS Program Manager requested the NASA Engineering and Safety Center (NESC) to characterize and quantify sensitivities of Loctite® being used as a secondary locking feature. The ISS Program feels they have experienced acceptable reliability with Loctite® and would like to determine under what conditions this type of LLC will provide predictable results.

The findings and recommendations provided in this investigation apply to the anaerobic LLCs Loctite® 242 and 271. No other anaerobic LLCs were evaluated for this investigation.

The following findings were identified during this investigation: Loctite® 242 and 271 provide resistance to preload reduction (i.e., vibration loosening) as least as good as that provided by locking inserts; military and industry specifications regarding the application and use of LLCs are inconsistent and contradictory; proper application processes must be developed for each unique application using LLCs; and the primary factors that affect LLC cure include: substrate cleanliness; proper substrate surface activation; thread class; hole type; and LCC application to both the female and male substrate surfaces.

NESC recommendations for the use of Loctite® 242 and 271 follow: these specific LLCs are acceptable for use as a secondary locking feature for space hardware; development of LLC application processes that produce sufficient cure for the substrates to which applied is required by hardware developers; development of procedures and tests that verify sufficient LCC cure is required by hardware developers ; operations process controls must prevent contamination of LLCs prior to, during, and after application processes; installation operations must use activators on inactive/less active substrates and apply activator to both female and male fastening system components; hardware developers must determine the torque-tension tightening behavior of fastening system hardware using LLCs; hardware developers should install fasteners with LLCs to torque levels that produce the desired preload in the joint ; apply LLCs to both the female and male threaded surfaces during application processes; clean and activate both female and male substrate surfaces prior to applying LLCs; and do not use LLCs on hardware that has dry film lubrication (DFL) applied to either female or male threaded surfaces.

	NASA Engineering and Safety Center Technical Assessment Report	Document #: NESC-RP-04-092	Version: 1.0
Title: Evaluate the Performance of Loctite® as a Secondary Locking Feature for ISS Fasteners		Page #: 10 of 205	

Adherence to these recommended actions will allow the use of LLCs as secondary locking features, minimize the potential for fastener preload reductions, and maximize the reliable use of mechanically fastened joints.

	NASA Engineering and Safety Center Technical Assessment Report	Document #: NESC-RP-04-092	Version: 1.0
Title: Evaluate the Performance of Loctite® as a Secondary Locking Feature for ISS Fasteners		Page #: 11 of 205	

5.0 Assessment Plan

An independent review of the sensitivities of Loctite® 242 and 271 for use as a secondary locking feature for ISS and flight vehicle applications was conducted. Testing and analyses were performed to determine Loctite® 242 and 271 sensitivities both as independent parameters and to define the boundaries for combinations of these parameters that result in a reliable secondary locking feature. Work completed in this assessment included:

1. Loctite® design practices
2. LLC qualification test standards
3. Loctite® application processes
4. Loctite® sensitivity identification, testing, and analysis
5. Recommended Loctite® 242 and 271 installation practices and processes

The assessment was conducted in three phases: Zero, I, and II, which are described in detail in Section 7.0.

Phase Zero

Phase Zero was an initial quick-look effort conducted to evaluate the effects of vibration on fasteners with Loctite® 242 LLC and Braycote® 601 lubricant applied to the threads and installed to various preload levels.

Phase I

Phase I defined a test and analysis plan to determine Loctite® 242 and 271 sensitivity factors and the exposure environment for the ISS application. The parameters and influencing factors included environmental-related (e.g., thermal, vacuum, vibration, interactions with other materials), process-related (e.g., preparation, compound application, curing), and design-related (e.g., materials, finishes, primers, tolerances, fastener preload, joint thickness, joint stiffness, fastener dimensions) factors. In addition, Military Specification (MIL-S)-46163A, National Aerospace Standard – former military (NASM) 1312/1-9, and American Society for Testing and Materials (ASTM) D5363 were evaluated to determine if they appropriately reflected installation practices and processes.

Phase II

Phase II quantified Loctite® 242 and 271 sensitivities by testing and analyses. As a result, recommendations for installation practices and processes for improved reliability of using Loctite® 242 and 271 as a fastener secondary locking feature were developed.

	NASA Engineering and Safety Center Technical Assessment Report	Document #:	Version:
		NESC-RP-04-092	1.0
Title: Evaluate the Performance of Loctite® as a Secondary Locking Feature for ISS Fasteners			Page #: 12 of 205

6.0 Problem Description and Proposed Solutions

ISS fastening system hardware use anaerobic LLCs as a means of meeting secondary locking feature requirements. During ground vibration testing, joints that had been assembled with LLCs failed to prevent fastener loosening (i.e., preload loss). The reliability of LLC compounds for use as secondary locking features was questioned due to these failures, and the Johnson Space Center engineering community implemented a policy restricting the use of LLCs as a secondary locking feature.

Military and industry standards for LLCs are inconsistent and contradictory. An effort to understand and quantify the sensitivities of LLCs as secondary locking features is required. Robust LLC installation processes are required that provide adequate curing of the compounds for applications where used, and that increase the reliability for their use in intended vibration environments.

7.0 Data Analysis

7.1 Establishment of Relevant Loctite® 242 and 271 Sensitivity

7.1.1 Parameters Effecting Cure (Design, Process, Environmental)

There are many parameters that can have an effect on the curing of Loctite® 242 and 271. Primary parameters listed are those that have been identified as contributors in various product specifications, LLC specifications, and contractor installation standards and specifications. These parameters were divided into the categories of design, process, and environmental factors. The parameters identified are listed in Table 7.1-1.

Table 7.1-1 Parameters during Cure

Design	Process	Environmental
Material	Where applied	Temperature
Finish	How applied	Relative humidity
Part fit, tolerance, gap	How much applied	
Nut or insert	Surface prep/cleanliness	
Blind or thru hole	Shelf Life	
Part fit, tolerance, gap	Activator or none	
Preload	Cure rate	
Ability to disassemble		

As indicated in Loctite® 242 and 271 product literature, cure rate will depend upon the substrate used and temperature. The cure time to achieve 100 percent of the breakaway strength is increased for less active substrates (e.g., stainless steel), and a higher breakaway strength can be achieved at lower cure times with higher temperature. However, the maximum breakaway is not dependent on temperature. Activators are documented in product literature as improving the

	NASA Engineering and Safety Center Technical Assessment Report	Document #: NESC-RP-04-092	Version: 1.0
Title: Evaluate the Performance of Loctite® as a Secondary Locking Feature for ISS Fasteners			Page #: 13 of 205

cure rate when cure times are unacceptably long, or where large gaps are present between the LLC and the substrate. No mention is made of the effects of pressure and percent humidity on the cure rate. For best results, the substrate surfaces should be cleaned and allowed to dry and either inherently active or coated with activator. As indicated in the product literature, aqueous washing systems should be checked for compatibility with the LLC. As indicated in the product literature, for thru holes, the LLC should be applied to the bolt at the nut engagement area. For blind holes, the LLC should be applied to the internal threads to the bottom of the hole. For sealing applications, a 360-degree bead of LLC should be applied to the leading threads of the male part, leaving the first thread free. The LLC should be forced into the threads to fill the voids. For larger threads and gaps, the LLC application should be adjusted to apply a 360-degree bead of LLC on the female threads. No assembly preloads are specified. The LLC is stated to be usable if stored in the unopened container in a dry location within the temperature range of 46 to 60 °F. Care should be taken to prevent contamination of LLC in containers from which product has been dispensed. The container applicator should not touch the substrate to which the LLC is dispensed to prevent potential contamination.

As indicated in the Loctite® 242 and 271 product literature, stainless steel attains less than 40 percent of the LLC full strength after 24 hours. Henkel/Loctite® USA personnel (Appendix B) indicated that if no activator is used on inactive metals like stainless steel, most of the LLCs will take significantly longer to fully cure and the timeframe is highly unpredictable. It could take two to three weeks for LLCs on stainless steel substrates to fully cure without an activator. Full cure is defined as attaining 100 percent of the specified LLC breakaway strength.

As indicated in Loctite® 7644 and 7471 activator product literature, these activators are designed to promote the cure speed of Loctite® anaerobic adhesives and sealants. Activators are recommended for use on passive metals or inert surfaces and with large bond gaps up to 0.010 inches. Activator can be applied by spraying, brushing, wiping, or dipping. For small gaps (less than 0.010 inch), the treatment of one surface may be adequate. Activators should be allowed to dry completely prior to LLC application. Activated surfaces are stated to be good for bonding for various time limits after application (e.g., 7 days for Loctite® 7471 and 30 days for 7644). Conditions before reapplication is also required (i.e., should be free of contamination prior to application). The LLC can be applied to one or both fastening system surfaces and assembled immediately, then the surfaces moved in relation to each other for a few seconds on assembly to properly distribute the LLC and for maximum strength.

Cure time relative to obtaining specified locking torque values is addressed in MIL-S-22473E, *“The average locking torque of the compound after 6 hours of normal curing shall not be less than 50 percent and after 24 hours not less than 100 percent of the minimum value specified in Table I, when tested as specified in 4.6.2.1.4.”* Additionally, Loctite® 7644 and 7471 are designed to aid cure speed to meet the locking torque requirements for various substrate materials.

	NASA Engineering and Safety Center Technical Assessment Report	Document #: NESC-RP-04-092	Version: 1.0
Title: Evaluate the Performance of Loctite® as a Secondary Locking Feature for ISS Fasteners			Page #: 14 of 205

Cure speed relative to obtaining specified breakaway and prevailing torque values is addressed in MIL-S-46163, *“For types I, II, and III, the average breakaway and prevailing torque for steel shall be not less than that specified in 1.2.1 after 24 hours. Also, the breakaway and prevailing torque for steel shall be not less than 50 percent of that specified in 1.2.1 after 90 minutes for type I; 60 minutes for type II; and 15 minutes for type III. Tests shall be as specified in 4.6.2.1.3.”* Additionally, *“...the primer used in conjunction with types I, II, and III compounds on cadmium and zinc surfaces shall be compatible to the compounds and shall show a breakaway and prevailing torque of not less than 50 percent of the minimum specified in 1.2.1 after 15 minute; and not less than 100 percent of the minimum specified in 1.2.1 after 4 hours when tested as specified in 4.6.3.1.”* In the notes in Section 6.1, that *“All three types (I, II, III) are designed to lock thread assemblies against working loose under shock and vibration.”*

Cure time relative to obtaining specified breakaway and prevailing torque values at standard conditions and “speed of cure” conditions is addressed in ASTM D5363-03, *“The average strength of each adhesive, when tested in accordance with 7.7, shall meet the requirements specified for the given class in Table AN. Strength at standard conditions is obtained at 69.8°F - 77°F, 45-55 percent relative humidity and a cure time of 24-26 hours. And the measured parameter is breakaway and prevailing torque. Cure time for “speed of cure” tests varies from 15 minutes to 6 hours and the measured parameter is prevailing torque.”* This specification states it is not intended for engineering design purposes.

Typical breakaway and prevailing torque performance of cured material are indicated in Loctite® 242 and 271 product literature, MIL-S-22473E, and MIL-S-46163. “Cured material” is material that has attained 100 percent of the breakaway and/or prevailing torque strength levels specified in the documents for the specified LLCs. While the time or speed of cure may vary dependent upon parameters that affect cure, the typical torque strength performance requirements remain unchanged. Minimum vibration loosening (i.e., preload reduction) performance requirements for LLCs are not indicated in the Loctite® 242 and 271 product literature, and the military and industry specifications.

7.1.2 ISS Specific “Typical” Fastener and Process Configurations

Loctite® has been used in some locations for fastened joints on ISS Integrated Cargo Carrier (ICC)/External Stowage Platform (ESP)-2 hardware. Applications include the: Unpressurized Cargo Pallet (UCP) side brackets; Passive Flight Release Attachment Mechanism (FRAM) Adapter Plates; ExtraVehicular Activity (EVA) Node hole handrails; H-fixture brackets; External Stowage Platform Attachment Device (ESPAD) Assembly; and Keel Yoke.

Three main issues were identified by JSC engineering with the use of Loctite® on the ICC/ESP-2 hardware:

	NASA Engineering and Safety Center Technical Assessment Report	Document #: NESC-RP-04-092	Version: 1.0
Title: Evaluate the Performance of Loctite® as a Secondary Locking Feature for ISS Fasteners		Page #: 15 of 205	

1. The hardware manufacturer, European Aeronautic Defense and Space Company (EADS), did not identify in its build paper a specific process for use of Loctite[®], nor was the installation step specified to be “critical.”
 - a. Discussions by JSC ISS personnel with EADS indicated that while the drawings did not specify an installation procedure, EADS utilized an internal process (MA1031620) that was considered acceptable, except for the lack of application of an activator to the titanium inserts (see issue 2 below). EADS indicated that the same technician installed all of the ESP-2 hardware. This technician performed installations of Loctite[®] for a series of unique qualification tests for ESP-2 hardware. After observing the process used during these tests, it was assessed that EADS and the technician performing the test set-up were extremely professional and showed a high level of competence and understanding of the principles and processes used to develop and qualify the hardware. It was determined that processes used during the qualification testing were consistent in quality with processes used to assemble the flight hardware, and that this test effectively served as a “post-assembly” qualification test.
2. The internal process used by EADS to install the Loctite[®] did not call for the use of an activator to be applied to the titanium insert prior to installation of the fastener, which is contrary to the recommended practice as specified by the vendor.
3. The use of Loctite[®] in this application had not been specifically qualified for use as a secondary locking feature, either by Loctite[®], by a generic Military Specification, or by EADS. Most prevailing torque type locknuts and lockbolts are qualified through NASM 1312-7 Fastener Test Methods, Method 7 – Vibration, dated August 1997. However, locking inserts (including Heli-Coil[®], key locked-in, and thin wall locked-in) and LLCs are not.

Details of the preparation and application of LLCs for several ISS manufacturing vendor sites are provided in Section 7.9.

7.1.3 Establishment of Loctite[®] Relevant Post-Cure Environment Considerations (Humidity, Atomic Oxygen, Thermal, Vibration, etc.)

A variety of environments which the Loctite[®] would encounter at the ISS were identified and considered relative to Loctite[®] aging and degradation. The table “Space Flight Environments for ISS” provided in Appendix A was prepared for this exercise. Twelve environmental factors are listed in the first column. The source of these factors and the worst case value expected during use are listed in the second and third columns. Specific comments relative to the environmental factor are listed in the fourth column, and the NESC team’s evaluation rationales are listed in the fifth column.

	NASA Engineering and Safety Center Technical Assessment Report	Document #: NESC-RP-04-092	Version: 1.0
Title: Evaluate the Performance of Loctite® as a Secondary Locking Feature for ISS Fasteners			Page #: 16 of 205

The first two environmental factors involve the ambient atmosphere. While vacuum alone was considered a non-factor, the combination of vacuum with low or elevated temperatures or temperature cycling was considered to have a possible negative impact on Loctite® stability. Several tests were conducted to evaluate this effect on Loctite® and results are presented in Sections 7.7.1 through 7.7.4.

The next eight environmental factors involve radiation or atomic oxygen. All of these environments were considered inconsequential and were not subjects of testing because the Loctite® is located between the fastener threads and thus is not directly exposed to these environments.

The external contamination environmental factor was also considered inconsequential. The cured Loctite® materials were considered to be relatively stable with low amounts of out-gassing. Therefore, the likelihood of Loctite® causing external contamination was considered to be low.

The final environmental factor considered was on-orbit humidity, which of course is zero in the external vacuum application. This was also considered to be inconsequential because the Loctite® can be used immersed in water after cure according to the product information sheets.

7.1.3.1 Questions/Discussions with Henkel Loctite®

Throughout the Loctite® assessment, the NESC team developed questions for a Henkel/Loctite® USA Technical Representative. These technical questions addressed many different areas and helped increase the team's understanding of the different Loctite® products, product application procedures, and usage environments. The questions were compiled and forwarded to the Henkel Technical Representative. The questions provided, and the unedited answers as received are included in Appendix B along with the Technical Representative's contact information.

In summary, this question and answer exchange proved to be valuable in helping the NESC team better understand Loctite® LLCs. It also provided clarification for numerous company procedure documents evaluated by the team.

7.2 Phase Zero Testing

Prior to the start of Phase I testing, a quick-look Phase Zero test program was conducted. The test program was performed to evaluate the effects of vibration on fasteners with Loctite® 242 LLC or Braycote® 601 lubricant applied to the threads, and installed to various preload levels.

Prior to vibration testing, torque-tension testing was performed on each sample combination, as described in Table 7.2-1, to determine approximate torque values to use during vibration testing. The torque-tension values used for vibration testing and the expected preload values are shown in Table 7.2-1. Vibration testing was performed using NASM 1312-7.



NASA Engineering and Safety Center Technical Assessment Report

Document #:
NESC-RP-04-092

Version:
1.0

Title:

Evaluate the Performance of Loctite® as a Secondary Locking Feature for ISS Fasteners

Page #:
17 of 205

Table 7.2-1. Phase Zero Vibration Test Matrix

Sample	Fastener	Insert Type	Loctite® LLC	Loctite® Activator	Lubricant	Torque (in-lbs)	Preload (lbs)
A1-A5	NAS1953	MS21208F1-20	242	7471	N/A	90	2,000
A6-A10	NAS1953	MS21208F1-20	242	7471	N/A	50	1,000
A11-A15	NAS1953	MS21208F1-20	242	7471	N/A	25	500
N1-N5	NAS1953	MS51830-201	N/A	N/A	Braycote® 601	80	2,000
N6-N10	NAS1953	MS51830-201	N/A	N/A	Braycote® 601	40	1,000

Testing was performed using the following items and depicted in the following figures:

- 4130 steel test fixture (Figure 7.2-1) and spacers (Figure 7.2-3)
- Aluminum:
 - Test fixture pins (Figure 7.2-2)
 - Spacers (Figure 7.2-3)
 - Washers (Figure 7.2-4)
 - Test blocks (Figure 7.2-5)

NAS1587A3C washers were used under the fastener head during testing. Inserts used for the testing were non-locking CRES, per Table 7.2-1, installed into aluminum test blocks. Three to five fasteners were tested at a time. The test instructions are provided in Section 7.2.1, following Figures 7.2-1 through 7.2-5.

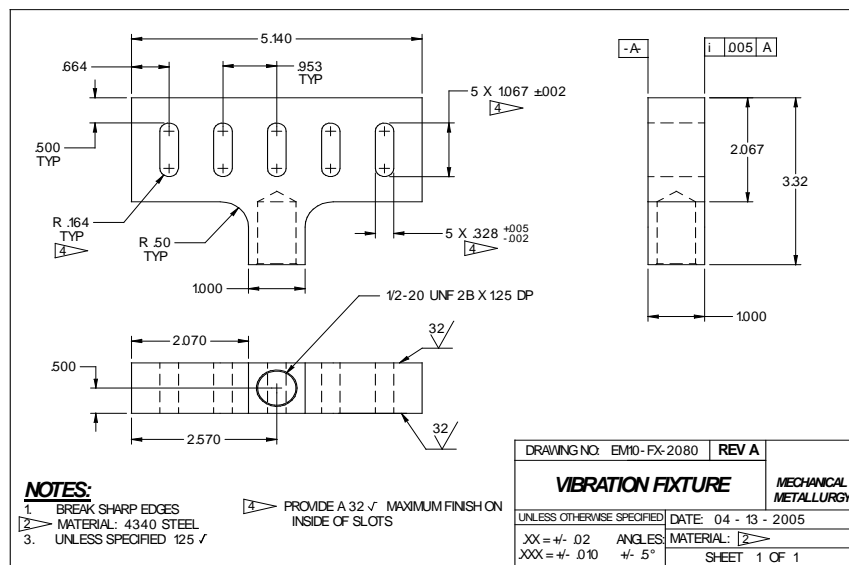

Figure 7.2-1. Vibration Test Fixture



NASA Engineering and Safety Center Technical Assessment Report

Document #:
**NESC-RP-
04-092**

Version:
1.0

Title:

Evaluate the Performance of Loctite® as a Secondary Locking Feature for ISS Fasteners

Page #:
18 of 205

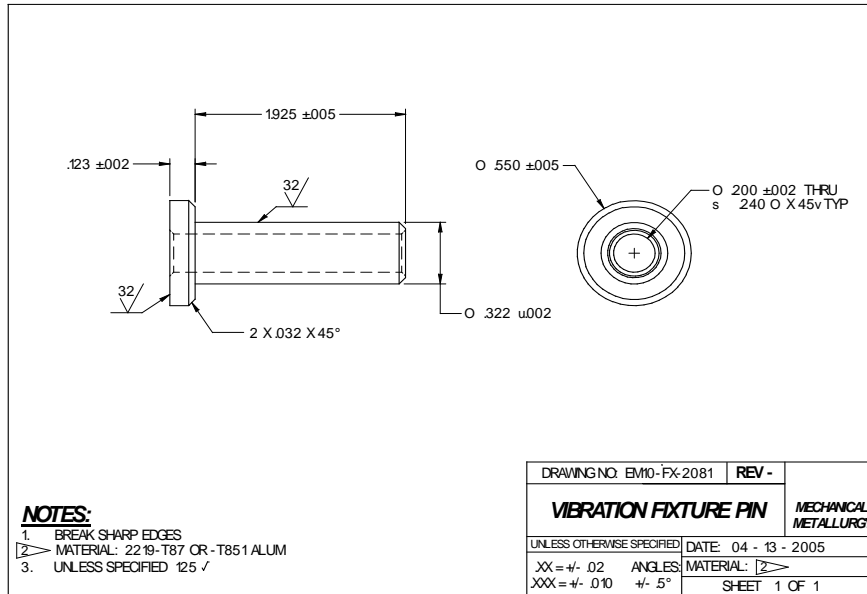

Figure 7.2-2. Vibration Fixture Pin

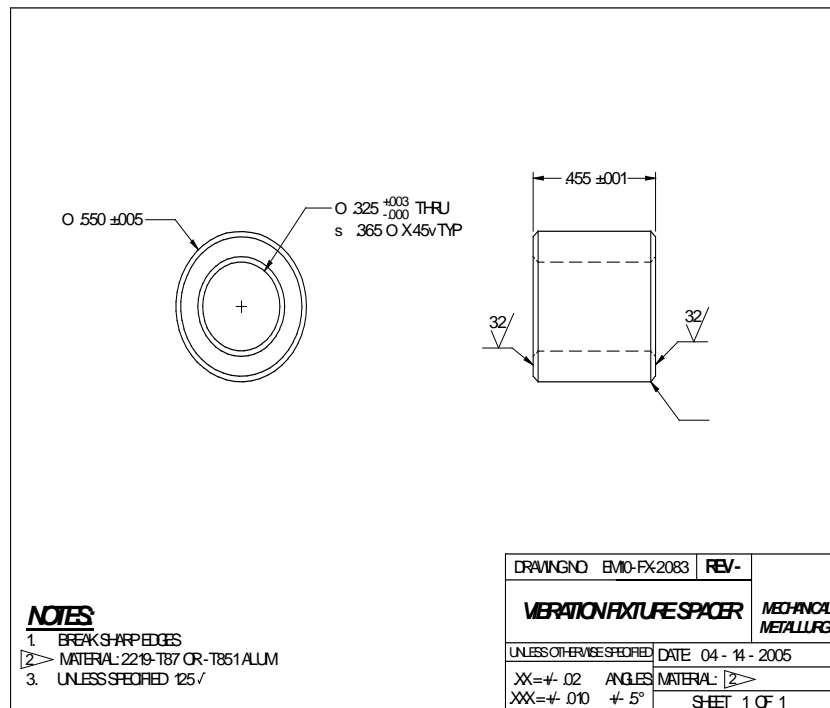

Figure 7.2-3. Vibration Fixture Spacer



NASA Engineering and Safety Center Technical Assessment Report

Document #:
**NESC-RP-
04-092**

Version:
1.0

Title:

Evaluate the Performance of Loctite® as a Secondary Locking Feature for ISS Fasteners

Page #:
19 of 205

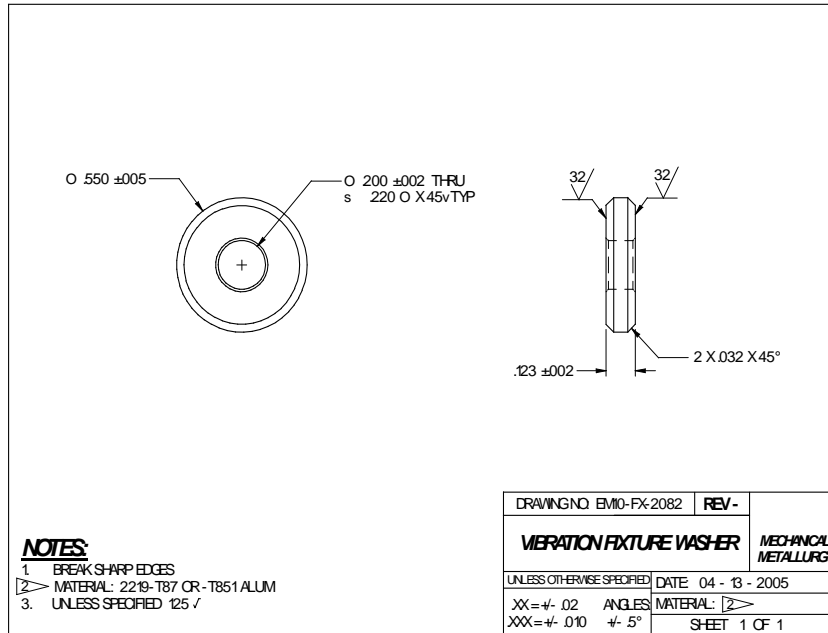

Figure 7.2-4. Vibration Fixture Washer

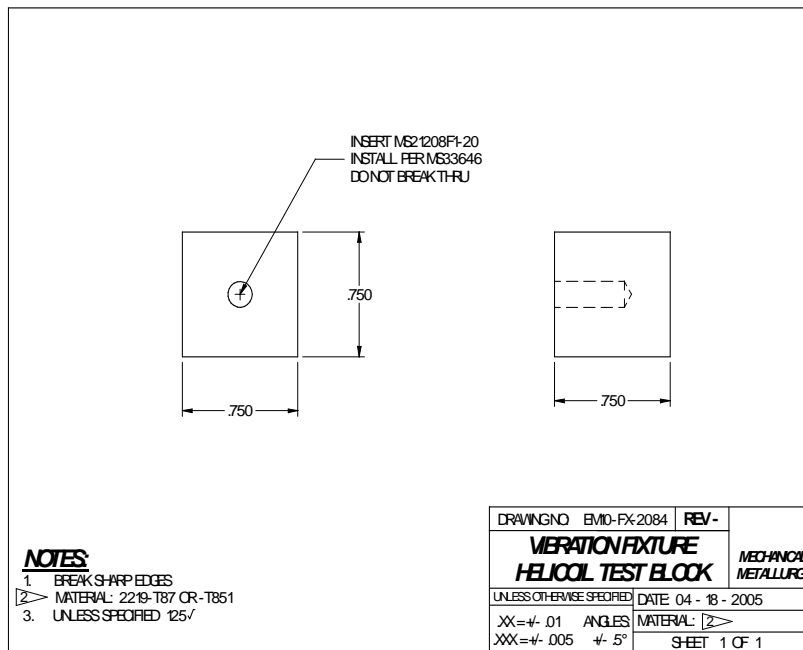



Figure 7.2-5. Vibration Fixture, Helicoil® Test Block

	NASA Engineering and Safety Center Technical Assessment Report	Document #: NESC-RP-04-092	Version: 1.0
Title: Evaluate the Performance of Loctite® as a Secondary Locking Feature for ISS Fasteners		Page #: 20 of 205	

7.2.1 Test Instructions

1. Test in the sequence specified in Table 7.2-1 (e.g., start with the A1-A5 inserts).
2. Assemble fasteners into test fixture in series. (BOLTS AND INSERTS CLEANED? WASHERS AS-RECEIVED?)
3. Apply Loctite® 7471 activator to fastener and insert threads. Let dry for 15 minutes minimum.
4. Apply Loctite® 242 LLC to fastener and insert threads using a swab. Record Loctite® 242 expiration information.
5. Torque each fastener/insert to the value specified in Table 7.2-1. Record the torque values. Record the date and time that the Loctite® 242 was applied and the fastener torqued. Record torque wrench/transducer calibration information.
6. Mark the insert block/washer interfaces with a permanent scribe mark. Take a typical photograph.
7. Let the Loctite® 242 cure for 30 ± 2 hours prior to testing.
8. Photograph the test set up.
9. Assemble the vibration test fixture onto the test machine.
10. Test per NASM 1312-7 Vibration Test Procedures for 8 minutes duration. (LUBRICATED SPOOLS?) Record the date and time of testing. Stop the test if it is apparent that the fasteners are loosening (losing preload).
11. Videotape the testing.
12. Record all test anomalies post test.

7.2.2 Test Results

Test results are shown in Table 7.2-2.



NASA Engineering and Safety Center Technical Assessment Report

Document #:
NESC-RP-04-092

Version:
1.0

Title:

Evaluate the Performance of Loctite® as a Secondary Locking Feature for ISS Fasteners

Page #:
21 of 205

Table 7.2-2. Phase Zero Vibration Test Results (A1-A15 w/ Loctite® 242; N1-N10 w/ Braycote® 601 lubricant)

VIBRATION TESTING OF INSERTS INSTALLED WITH LOCKING COMPOUND									
INSERT No.	Torque (in-lbs)	Preload (lbs)	Date Installed	Time Installed	Date Tested	Time Tested	Torque Applied (in-lbs)	Break Loose Torque (in-lbs)	Comments
A1	90	2000	9/15/2005	12:40	9/19/2005	10:00	91.28	73.34	At 00:04:40 (8400 cycles) all 5 Fastener clewing were stuck in Fixture.
A2	90	2000	9/15/2005	12:40	9/19/2005	10:00	90.80	74.45	Remake 6061 cylinders out of 4340.
A3	90	2000	9/15/2005	12:40	9/19/2005	10:00	91.34	80.95	Aluminum 6061 cylinders galled, stuck and stopped vibrating in the steel clevis.
A4	90	2000	9/15/2005	12:40	9/19/2005	10:00	90.37	72.00	Threads 100% coated with loctite by dipping.
A5	90	2000	9/15/2005	12:40	9/19/2005	10:00	90.25	59.17	
A6	50	1000	10/28/2005	8:20	10/31/2005	1:45	50.71	14.96	No failures during vibration testing
A7	50	1000	10/28/2005	8:20	10/31/2005	1:45	50.66	25.77	No failures during vibration testing
A8	50	1000	10/28/2005	8:20	10/31/2005	1:45	51.25	21.46	No failures during vibration testing
A9	50	1000							Threads 100% coated with loctite by dipping.
A10	50	1000							
A11	25	500	10/20/2005	1:40	10/25/2005	10:30	25.45	3.27	Alignment marks moves slightly after test.
A12	25	500	10/20/2005	1:40	10/25/2005	10:30	25.44		Failed Virbration Test @ 3.5 min. (6290 cycles). Came out of fixture.
A13	25	500	10/20/2005	1:40	10/25/2005	10:30	25.53		Failed Virbration Test @ 3 min. (5300 cycles). Came out of fixture.
A14	25	500							
A15	25	500							
N1	80	2000	12/9/2005	11:00	12/9/2005	12:30	79.72	46.05	All fasteners passed testing
N2	80	2000	12/9/2005	11:00	12/9/2005	12:30	81.41	62.47	All fasteners passed testing
N3	80	2000	12/9/2005	11:00	12/9/2005	12:30	81.47	58.46	All fasteners passed testing
N4	80	2000	12/9/2005	11:00	12/9/2005	12:30	81.18	42.93	All fasteners passed testing
N5	80	2000							
N6	40	1000	11/1/2005	3:20	11/1/2005	3:45	39.97		All fasteners failed within 45 seconds of test start - came out of fixture.
N7	40	1000	11/1/2005	3:20	11/1/2005	3:45	39.97		All fasteners failed within 45 seconds of test start - came out of fixture.
N8	40	1000	11/1/2005	3:20	11/1/2005	3:45	40.03		All fasteners failed within 45 seconds of test start - came out of fixture.
N9	40	1000	11/1/2005	3:20	11/1/2005	3:45	40.06		All fasteners failed within 45 seconds of test start - came out of fixture.
N10	40	1000	11/1/2005	3:20	11/1/2005	3:45	41.02		All fasteners failed within 45 seconds of test start - came out of fixture.

7.2.3 Discussion

Samples A1-A5 were installed with Loctite® 242 and torqued to 90 in-lbs representing a preload of approximately 2,000 pounds. During sample A1-A5 testing, the aluminum spacer galled and eventually froze in the steel test fixture. While none of the fasteners loosened during vibration testing, these tests were deemed invalid due to the spacer degradation. NASM 1312-7 specifies hardened steel for the fixture, pins, and spacers. The aluminum spacers were replaced with 4130 steel spacers for the subsequent tests.

Samples A6-A8 were installed with Loctite® 242 and torqued to 50 in-lbs representing a preload of approximately 1,000 pounds. The samples A6-A8 completed vibration testing without any relative movement of the scribe marks between the insert block/interfaces. No discernable movement of the scribe marks is considered acceptable performance of the configuration. Breakloose torques ranged from 30 to 52 percent of the installation torque values.

Samples A11-A13 were installed with Loctite® 242 and torqued to 25 in-lbs representing a preload of approximately 500 pounds. For sample A11, rotation was indicated by inspection of

	NASA Engineering and Safety Center Technical Assessment Report	Document #: NESC-RP-04-092	Version: 1.0
Title: Evaluate the Performance of Loctite® as a Secondary Locking Feature for ISS Fasteners			Page #: 22 of 205

the scribe marks after testing. The breakloose torque was 13 percent of the installation torque value. Samples A12 and A13 failed the test by completely loosening and coming out of the test fixture.

Samples N1-N4 were installed with Braycote® 601 grease and torqued to 80 in-lbs representing a preload of approximately 2,000 pounds. The samples N1-N4 survived vibration testing, without any relative movement indicated by the scribe marks between the insert block/interfaces. Breakloose torques ranged from 54 to 78 percent of the installation torque values.

Samples N6-N10 were installed with Braycote® 601 lubricant and torqued to 40 in-lbs representing a preload of approximately 1,000 pounds. The samples N6-N10 failed vibration testing. Failures occurred within 45 seconds of the start of the test when the fasteners came out of the steel test fixture.

7.2.4 Conclusions

Vibration loosening is more effectively resisted by higher preloads (the primary locking feature). Comparing the A6-A8 and N6-N10 samples (both preloaded to approximately 1,000 lbs), Loctite® 242 prevented vibration loosening at this preload. Loctite® 242 was ineffective in providing loosening resistance for samples A11-A13 with the lowest preload of approximately 500 pounds.

7.3 Phase I Sensitivity Testing

Fourteen configurations were tested in an attempt to ascertain the sensitivity of Loctite® 242 and 271 breakloose torque strength to various factors. The factors examined included fastener diameter (0.164, 0.25, and 0.50 inch), female fastener configuration (non-locking Heli-coil® insert, H₂ tapped hole, and H₄ tapped hole), hole type (blind and thru hole), activator (Loctite® 7471 and none), cleaning (Methyl-Ethyl-Ketone (MEK) and none), LLC (Loctite®242 and 271), and fastener torque level (25, 50, 75, and 100 percent of the fasteners yield strength). Note that H₂ has 0.0010 inch tap cut over basic, whereas H₄ has 0.0020 inches over basic. The test parameters and procedure are described in Appendix C. The male and female fastener configuration details are provided in Table 7.3-1.

	NASA Engineering and Safety Center Technical Assessment Report	Document #:	Version:
		NESC-RP-04-092	1.0
Title: Evaluate the Performance of Loctite® as a Secondary Locking Feature for ISS Fasteners			Page #: 23 of 205

Table 7.3-1. Fastener configurations for Phase I Breakloose Torque Testing

Male Fastener				
Size (in)	Type	Class	Material	Finish
.1640-32	NAS 1352N-08-X	UNRC-3A	CRES A286	Passivated
.2500-28	NAS 1004-X	UNJF-3A	CRES A286	Passivated
.5000-20	NAS 1008-X	UNJF-3A	CRES A286	Passivated
Female Fastener				
	Type	Thread class	Material	Finish
.1640-32	Non-locking helicoil MS 122119	Coarse 1.5D	CRES 300 in AL plate	Passivated
.2500-28	Non-locking helicoil MS 124696	UNJF 1.5D	CRES 300 in AL plate	Passivated
.5000-20	Non-locking helicoil MS 124700	UNJF 1.5D	CRES 300 in AL plate	Passivated

Testing was performed on plates with an array of four by eleven holes. Fasteners were installed in each row at 25, 50, 75, and 100 percent of Johnson’s two-thirds yield load values (refer to NASM1312-8 for Johnson’s two thirds approximate method for determination of yield strength in fasteners). The first hole in each row was instrumented with a load cell to measure bolt preload. Eight fasteners in each row were installed with Loctite® LLC. The remaining three fasteners were installed with Braycote® 601 lubricant as a control. The test matrix for the Phase I sensitivity testing is shown in Table 7.3-2. Items in bold are replicates of the same baseline conditions.

Table 7.3-2. Phase I Sensitivity Test Matrix

Test Plate ID	Male Fastener	Female thread	Hole	Bolt cleaning	Activator type	Loctite type
16TP-1	0.164	Non-locking helicoil	thru	Isopropyl	T-7471	242
25TP-1	0.25	Non-locking helicoil	thru	Isopropyl	T-7471	242
25TP-2	0.25	Non-locking helicoil	blind	Isopropyl	T-7471	242
25TP-3	0.25	H2 tap in A286	thru	Isopropyl	T-7471	242
25TP-4	0.25	H4 tap in A286	thru	Isopropyl	T-7471	242
25TP-5	0.25	H4 tap in A286	blind	Isopropyl	T-7471	242
25TP-7	0.25	Non-locking helicoil	thru	Isopropyl	T-7471	242
25TP-8	0.25	Non-locking helicoil	thru	Isopropyl	T-7471	242
25TP-7a	0.25	Non-locking helicoil	thru	Isopropyl	no activator	242
25TP-8a	0.25	Non-locking helicoil	thru	No cleaning	T-7471	242
25TP-9	0.25	Non-locking helicoil	thru	Isopropyl	T-7471	242
25TP-10	0.25	Non-locking helicoil	thru	Isopropyl	T-7471	242
50TP-1	0.5	Non-locking helicoil	thru	Isopropyl	T-7471	271
50TP-2	0.5	H4 tap in A286	blind	Isopropyl	T-7471	271

An unknown event adversely affected the torque values of test plate 25TP-9 as the breakloose torque values were found to be much lower than those of the four other test plates with the same configurations. Thus, Test Plate 25TP-9 was excluded from analysis.



NASA Engineering and Safety Center Technical Assessment Report

Document #:
NESC-RP-04-092

Version:
1.0

Title:

Evaluate the Performance of Loctite® as a Secondary Locking Feature for ISS Fasteners

Page #:
24 of 205

Analysis of variance (ANOVA) is a statistical test of whether or not the means of several groups are all equal and is useful when comparing three or more means¹. ANOVA of breakloose torque values for the fasteners installed at 100 percent of Johnson’s two-thirds yield suggested that none of the test factors affected breakloose torque (see Figure 7.3-1). ANOVA on the lower installation torque values indicated the plates did differ (for raw data and ANOVA analyses for Section 7 not in this document see URL: <http://www.nasa.gov/offices/nesc/home/index.html>). However, when panels with the same configuration are compared (25TP-1, 7, 8, and 10), the breakloose torque values still differ for the plates. This seeming paradox can be resolved when a comparison between installation torque and breakloose torque is made (Figure 7.3-2). Installation torque is the overwhelming factor affecting breakloose torque. It became apparent that if an analysis of sensitivities affecting Loctite® LLC cure and subsequent breakloose strength is to be made, then the effect of initial torque should be eliminated. Thus, it was decided to repeat sensitivity testing with initial torque values of zero. This testing is discussed in Section 7.5.

It should be noted that the breakloose torque values for this phase were on fasteners that had not experienced vibration or cyclic loading. This may explain the lack of variation between bolts installed with Braycote® 601 lubricant and Loctite® LLC.

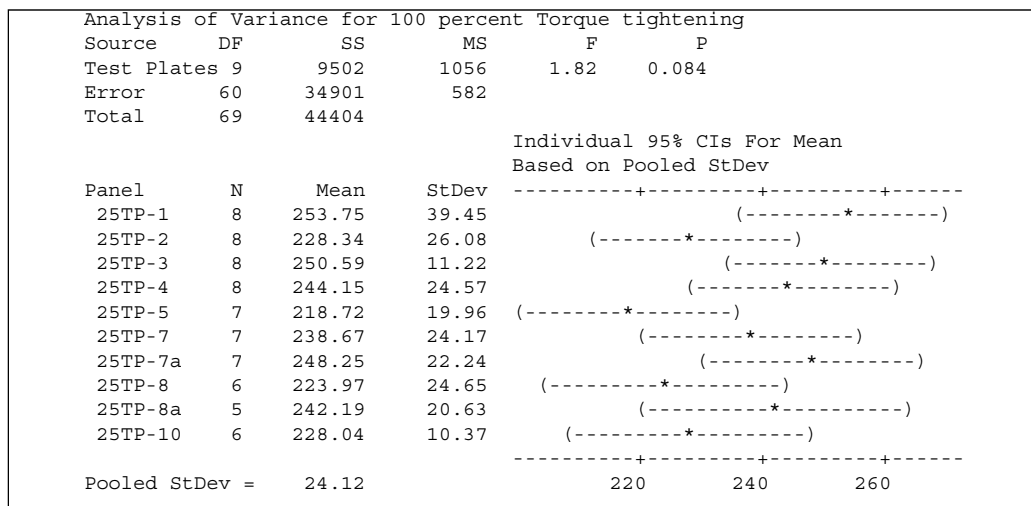

Figure 7.3-1. ANOVA on Phase I Breakloose Torque (100 percent initial torque on 0.25 inch fasteners)

¹ For more information on the ANOVA method of analysis refer to Montgomery, Douglass C., *Design and Analysis of Experiments*, 4th Edition, John Wiley and Sons, (1997) pp. 63-117.



Title:

**Evaluate the Performance of Loctite® as a Secondary
Locking Feature for ISS Fasteners**

Page #:
25 of 205

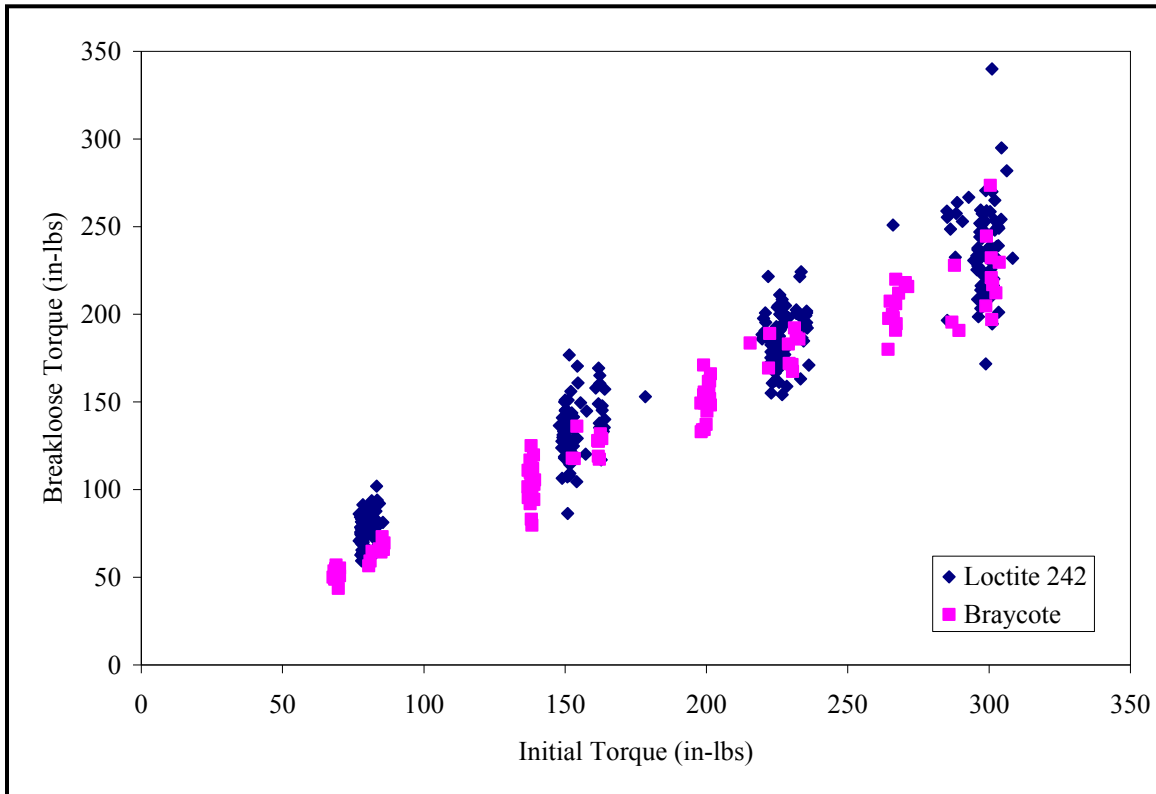

Figure 7.3-2. Scatter Plot for Breakloose Torque versus Installation Torque

7.4 Demonstrating Loctite® 242 Cure is not a Function of Preload

A test series was run to determine if preload affects the cure of Loctite® LLC. A test fixture (i.e., specifically the zero load wedge fixture) was fabricated that was capable of releasing the preload on a fastener after torque was applied to the fastener. Loctite® 242 was applied to the fasteners, the NAS1004-8A CRES A286 0.250-28 fasteners were then torqued to 50 in-lbs, and the Loctite® 242 was allowed to cure for 48 hours. After the Loctite® 242 cure, the preload was removed and the breakaway strength of the fasteners was tested. Maximum breakaway torque and running torque were recorded. The parameters of the experiment are provided in Table 7.4-1.



**NASA Engineering and Safety Center
Technical Assessment Report**

Document #:
**NESC-RP-
04-092**

Version:
1.0

Title:

**Evaluate the Performance of Loctite® as a Secondary
Locking Feature for ISS Fasteners**

Page #:
26 of 205

Table 7.4-1. Zero Load Wedge Fixture Test Details

LLC	Loctite® 242 (ASTM D5363-03 Group 03, Class 2, Grade 1, blue) and (MIL-S-46163A Type II, Grade N)
Activator	Loctite® 7471 (Grade T)
Fastener	NAS1004-8A CRES A286 0.250-28
Insert	NASM 124696 CRES Heli-Coil® Fine Thread 1.5 Diameter
Cure time	48 hours

The test was repeated to assess several factors including: initial preload level (50 and 0 in-lbs), cure environment (ambient atmosphere and rough vacuum – 28 in Hg), and hole type (blind and thru hole). The test conditions and breakaway strength results are shown in Table 7.4-2. It is shown by Two-factor ANOVA comparing initial preload and hole type that preload has no effect on breakaway strength. Further testing compared cure environment and hole type. In both cases, the hole type affected breakaway strength. Loctite® 242 cured for 48 hours in vacuum had an increased breakaway torque compared to Loctite® 242 cured in ambient atmosphere. Tables 7.4-3 and 7.4-4 show the ANOVA performed on the zero load wedge fixture test results. In the ANOVA, F values greater than the Fcrit values indicate statistically significant results for the parameters evaluated.

Table 7.4-2. Zero Load Wedge Fixture Test Results

Sample ID	Applied Torque (in-lbs)	Preload (lbs)	Breakloose Torque (in-lbs)	Hole Type
ZL-C-25-1	49.36	958	7.2	Blind
ZL-C-25-2	49.75	1033	4.1	Blind
ZL-C-25-3	50.28	1188	6.8	Blind
ZL-C-25-4	50.13	869	15.4	Thru
ZL-C-25-5	49.44	833	20.4	Thru
ZL-C-25-6	50.01	1038	13.4	Thru
ZL-C-25-10V	49.51	830	21.3	Thru
ZL-C-25-11V	49.61	1234	29.5	Thru
ZL-C-25-12V	50.05	1172	19.6	Thru
ZL-C-25-13V	50.28	968	11.2	Blind
ZL-C-25-14V	49.25	901	5.7	Blind
ZL-C-25-15V	49.52	1196	11.8	Blind
ZL-C-25-16H	Finger tight		13.7	Thru
ZL-C-25-17H	Finger tight		18.8	Thru
ZL-C-25-18H	Finger tight		15.3	Thru
ZL-C-25-19H	Finger tight		6.6	Blind
ZL-C-25-20H	Finger tight		8.2	Blind
ZL-C-25-21H	Finger tight		6.5	Blind

	NASA Engineering and Safety Center Technical Assessment Report	Document #:	Version:
		NESC-RP-04-092	1.0
Title: Evaluate the Performance of Loctite® as a Secondary Locking Feature for ISS Fasteners			Page #: 27 of 205

Table 7.4-3. Two-Factor ANOVA on Zero Load Wedge Fixture Test Results (Preload and Hole Type)

<i>Source of Variation</i>	<i>SS</i>	<i>df</i>	<i>MS</i>	<i>F</i>	<i>P-value</i>	<i>F crit</i>
Blind vs thru hole	276.29	1	276.29	46.76	0.000133	5.32
50 in-lb initial torque vs no initial torque	0.26	1	0.26	0.04	0.838	5.32
Interaction	1.79	1	1.79	0.30	0.597	5.32
Within	47.27	8	5.91			
Total	325.62	11				

Table 7.4-4. Two-Factor ANOVA on Zero Load Wedge Fixture Test Results (Cure Environment and Hole Type)

<i>Source of Variation</i>	<i>SS</i>	<i>df</i>	<i>MS</i>	<i>F</i>	<i>P-value</i>	<i>F crit</i>
Blind vs thru hole	441.90	1	441.90	31.64	0.000496	5.32
ambient vs vacuum cure	84.27	1	84.27	6.03	0.040	5.32
Interaction	9.36	1	9.36	0.67	0.437	5.32
Within	111.75	8	13.97			
Total	647.27	11				

7.5 Phase I(a) Zero Percent Preload Sensitivity Testing

A series of tests was conducted to establish Loctite® 242 breakaway strength sensitivities to various factors that could be present during installation. Factors examined included: cure time, contamination, hole type, application method, use of activator, humidity, and thread class on tapped hole. Because the wedge fixture testing successfully demonstrated that initial preload did not affect breakaway strength (after the preload was relaxed), sensitivity testing was performed without preload using aluminum panels with stainless inserts. Fasteners were installed in panels with four rows of eleven holes to examine various sensitivity factors. Fasteners and inserts were cleaned with MEK solvent prior to installation. Fasteners were then spray coated with Loctite® 7471 activator and allowed to dry at least 15 minutes. Loctite® 242 was applied by dropper to coat the fastener for thru hole installation. Loctite® 242 was applied to both fastener and insert for blind hole installation.

7.5.1 Effect of Cure Time

An initial series of tests was conducted on four panels to evaluate the effect of cure time on breakaway strength. No trend was observed in breakaway strength for fasteners in thru holes. However, the breakaway strength continued to increase to 96 hours for the blind holes (Figure 7.5-1). This testing established a cure time of 48 hours as sufficient for testing sensitivity factors on thru holes. The log curves in Figure 7.5-1 are fitted curves of the mean values of the thru and blind hole data sets.



Title:

Evaluate the Performance of Loctite® as a Secondary
Locking Feature for ISS Fasteners

Page #:
28 of 205

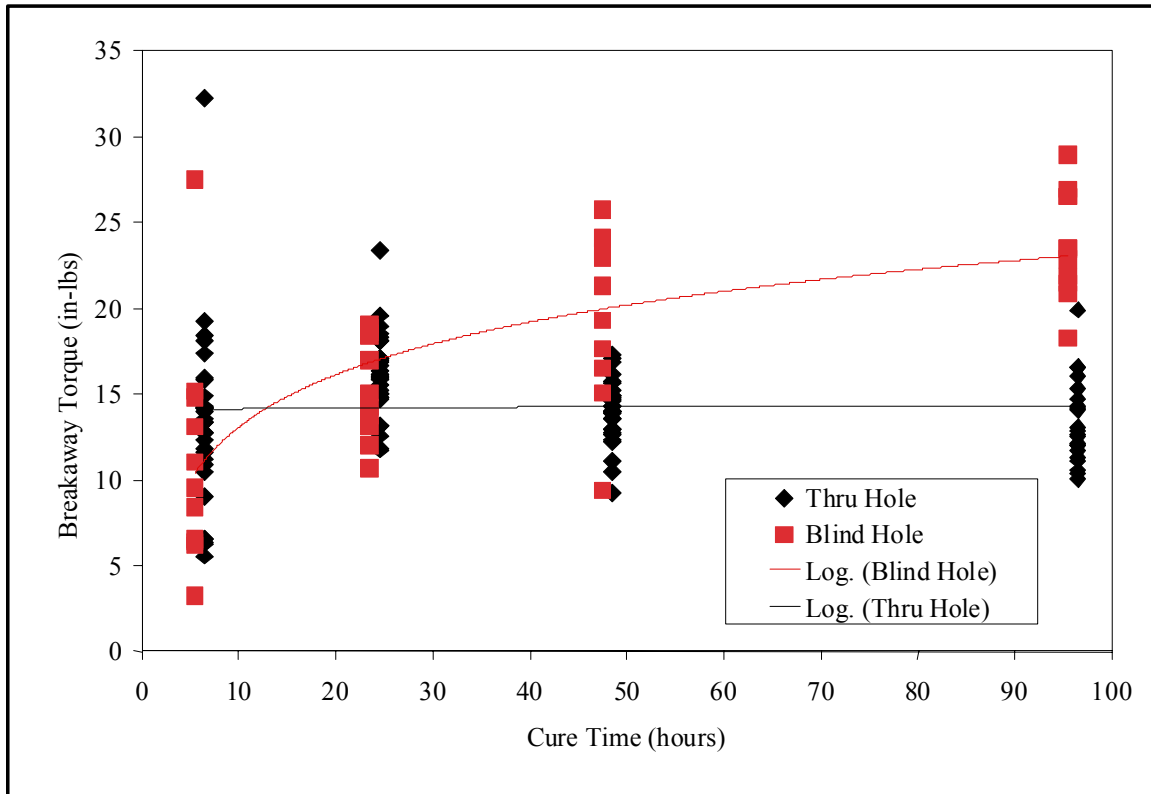

Figure 7.5-1. Breakaway Torque versus cure time for Loctite® 242

7.5.2 Effect of Contaminants

An attempt was made to determine how Loctite® 242 would adhere to DFL bolts. DFL bolts were installed and cured in the same manner as previous testing. Similarly, a second panel was used to evaluate the effect of Braycote® 601 lubricant contamination. Braycote® 601 was applied to inserts and subsequently cleaned off. Cleaning was performed by scrubbing the inserts with a test tube brush that had been immersed in MEK. Other contamination factors examined included using as-received fasteners and recycled inserts that contained residual Loctite® 242 from previous installations. No difference in breakaway strength is evident by ANOVA when inserts contaminated with Loctite® 242 are reused. A small difference was detected when the as-received fastener was used without cleaning. The greatest observed reduction in strengths was from contamination of DFL and insufficiently cleaned Braycote® 601 lubrication. More notable than the drop in average breakaway strength was the increase in variance. The contamination study results are displayed in Figure 7.5-2.



Title:

Evaluate the Performance of Loctite® as a Secondary Locking Feature for ISS Fasteners

Page #:
 29 of 205

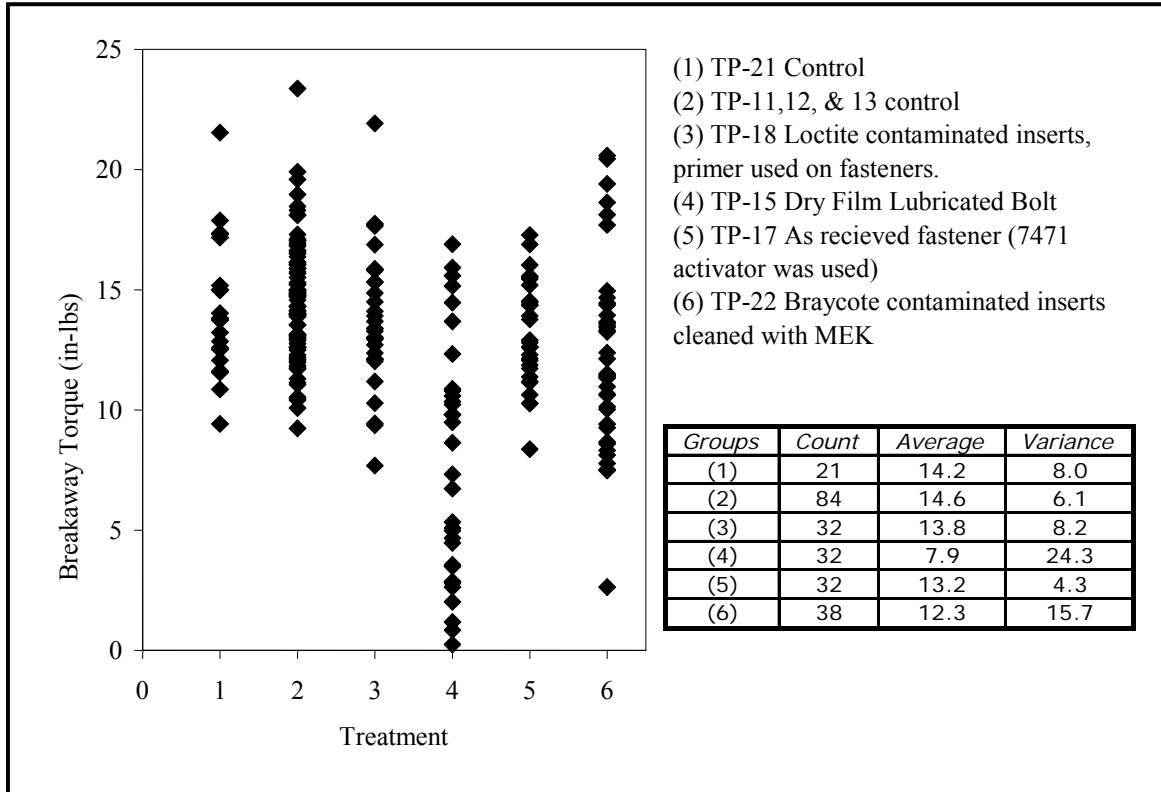

Figure 7.5-2. Effect of Contaminants on Breakaway Torque

7.5.3 Effect of Activator

The effect of Loctite® 7471 Grade T activator was examined in two series of tests. An activator is used for anaerobic LLCs to speed the cure time. Henkel/Loctite® USA recommends the use of an activator in applications with passive metals. A panel was prepared without using activator on the fasteners and compared to the control panels. The average breakaway strength when activator was not used had approximately a 10 percent lower value than when activator was used (Figure 7.5-3). Two additional panels from the contamination study (contaminated with residual Loctite® 242 in the inserts) were installed with fasteners that were activated on one panel and fasteners that were not sprayed with activator on the other panel. Again, the average breakaway strength when activator was not used had approximately a 10 percent lower value than when activator was used (Figure 7.5-3). These effects are statistically significant in the ANOVAs.



Title:

Evaluate the Performance of Loctite® as a Secondary Locking Feature for ISS Fasteners

Page #:
 30 of 205

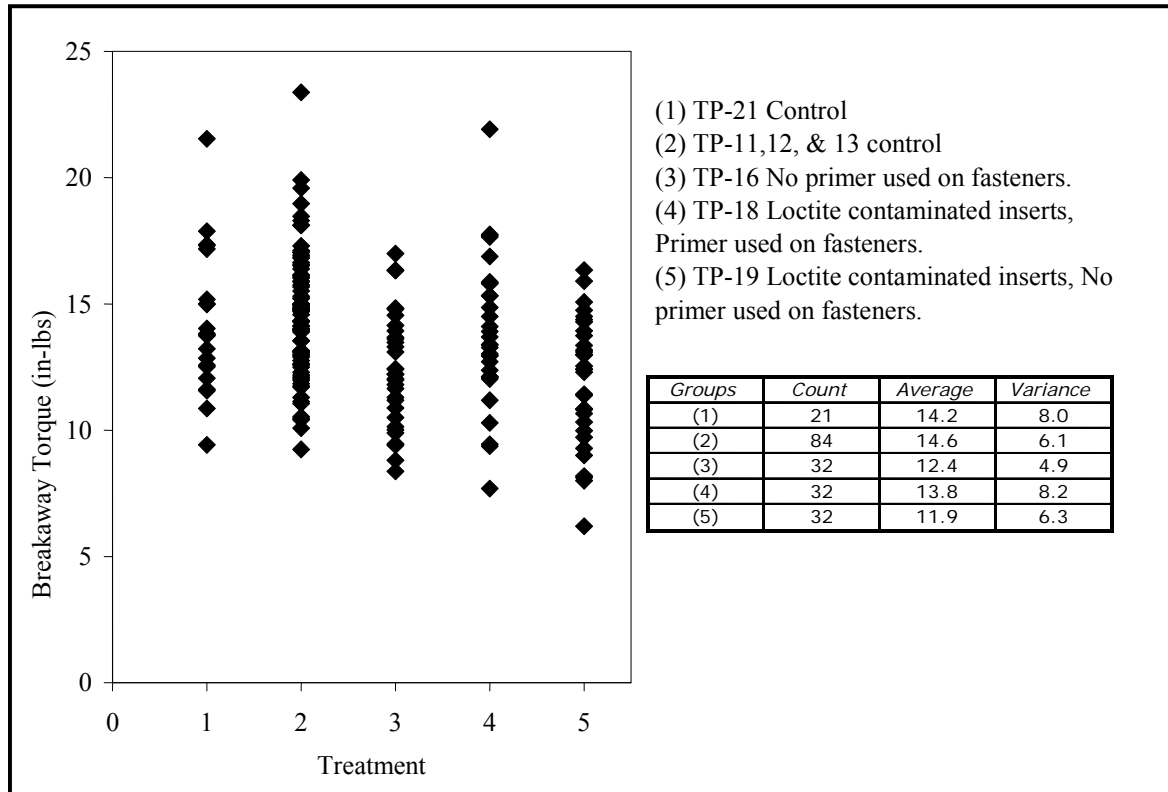

Figure 7.5-3. Effect of Activator use on Breakaway Torque

7.5.4 Effect of Thread Class on Tapped Hole

In this series of testing two A286 plates were substituted for the aluminum plates with non-locking Heli-coil® inserts. Four rows of eleven tapped holes had either an H₂ or H₄ class 3 thread tolerance. Plates and fasteners were cleaned and installed with the same method as before. Fasteners were installed to the same depth in all holes. Breakaway torque was measured after Loctite® 242 cure. The plate with H₂ thread had a 14 percent greater average breakaway torque than the H₄ thread (Figure 7.5-4). This effect is statistically significant in the ANOVA.



Title:

**Evaluate the Performance of Loctite® as a Secondary
Locking Feature for ISS Fasteners**

Page #:
31 of 205

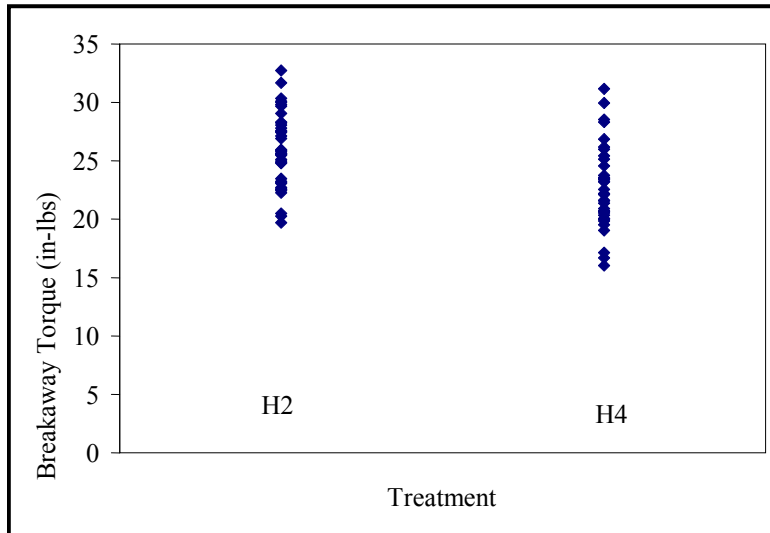

Figure 7.5-4. Effect of Thread Class on Breakaway Torques

7.5.5 Application Method Sensitivity Study

For the purpose of the sensitivity study, Loctite® 242 was applied per manufacturer's recommendations as a baseline. Henkel Loctite® USA recommends in the Technical Data Sheet for Loctite® 242 applying the LLC to the bolt only for thru holes, and down the internal threads to the bottom of the hole for blind holes. However, there are varying application procedures in actual use (see Section 7.9). It was also observed in this study that initial test results from blind holes had a higher breakaway torque than the thru holes. Was this a result of differing configuration or application? A comparison of the application technique with blind and thru holes was performed in which Loctite® 242 was applied to bolt only, and both bolt and insert for the two hole types. One thru hole panel and one blind hole panel had Loctite® 242 applied to only the fastener on half of the samples. The other half of the samples had Loctite® 242 applied to both the fastener and the insert. The thru hole panel replicated the earlier results. The samples with Loctite® 242 on both insert and fastener had a strength equivalent to the first series of blind hole tests (both surfaces coated). The samples with Loctite® 242 on only the fasteners had strengths equivalent to the earlier thru hole tests (only fastener coated). However, when the blind hole panel was repeated with the application method as the variable, the earlier results could not be replicated (See series 5 versus series 1 in Figure 7.5-5). The breakaway torque values were lower than expected based upon previous test results. The high variance suggests an unknown factor affected the test results. Despite the discrepancy in the data, coating both the female and male threaded surfaces results in a higher breakaway torque for either hole type.



Title:

Evaluate the Performance of Loctite® as a Secondary
Locking Feature for ISS Fasteners

Page #:
32 of 205

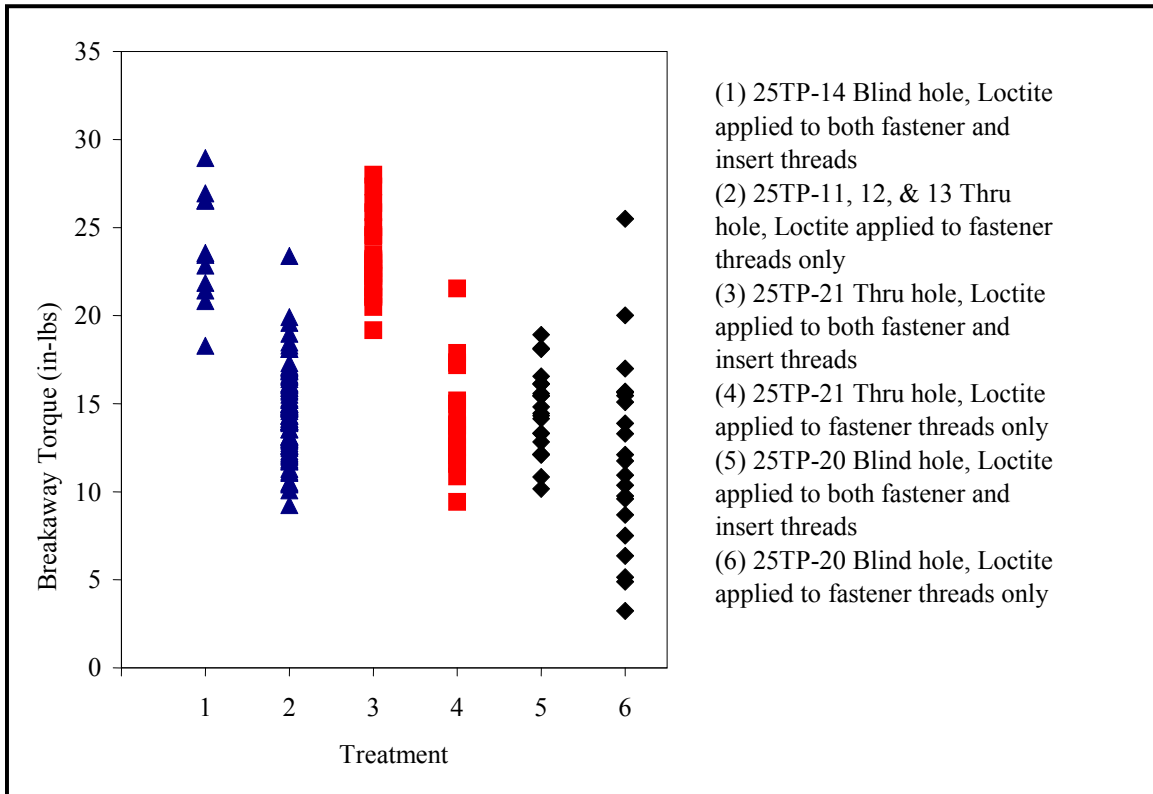

Figure 7.5-5. Effect of Application Method

7.5.6 Effect of Humidity on Cure

The effect of humidity on breakaway strength of Loctite® 242 was tested in a number of ways. The breakaway strength was measured after standard cure times (48 hours) in humidity, 48 hour cure in humidity followed by 48 hour exposure to ambient atmosphere, and standard 48 hour ambient atmosphere cure followed by 48 hour exposure to humidity. Humidity conditioning was performed in a humidity chamber at 90°F with 90 percent relative humidity. The test matrix was performed in replicate using two different Loctite® 242 application techniques. Fasteners were installed with Loctite® 242 applied to the fastener threads only and Loctite® 242 applied to both the fastener and the insert threads. Exposure to humidity negatively affected the breakaway strength of samples that had Loctite® 242 applied only to the fastener threads. Humidity had no effect on samples that had Loctite® 242 applied to both fastener and insert threads. One possibility is that the Loctite® 242 provides a better seal when both surfaces are coated. However, further testing is required to fully understand this phenomenon. Despite the potential interaction observed between humidity exposure and application technique, humidity is not a sensitivity factor when Loctite® 242 is applied to both fastener and insert threads (Figure 7.5-6).



Title:

Evaluate the Performance of Loctite® as a Secondary
Locking Feature for ISS Fasteners

Page #:
33 of 205

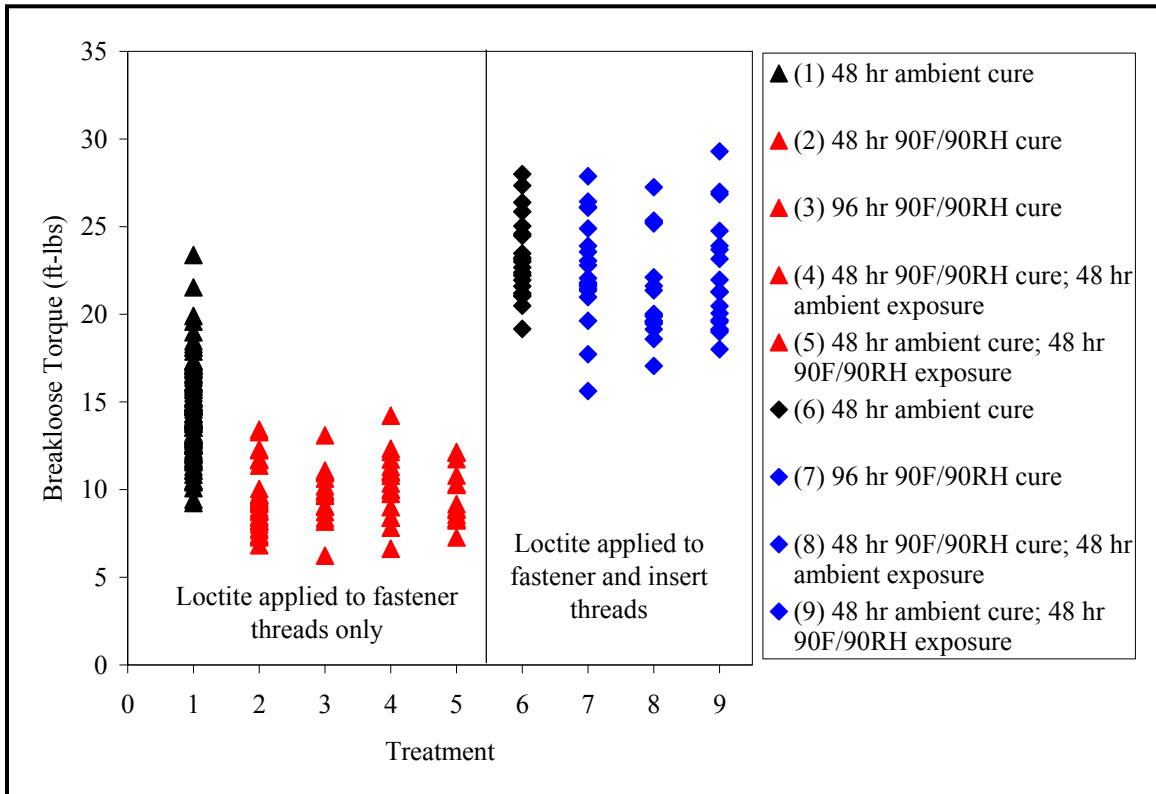



Figure 7.5-6. Effect of Humidity

7.5.7 Overall Conclusions for Zero Percent Preload Sensitivity Testing

Cure time was slower for blind holes compared to thru holes. Thru holes reached full strength in 6 to 24 hours, while blind holes continued to gain strength to 96 hours. The contamination study suggests that DFL bolts should not be used with Loctite® 242. When reinstalling a fastener with Braycote® 601 lubricant contamination present, cleaning should be performed prior to using Loctite® 242. Residual Loctite® 242 from a previous installation does not appear to be detrimental to the strength of a reinstalled fastener. Not using an activator on the stainless steel fastener resulted in an average decrease in breakaway strength of 10 percent. When using Loctite® 242 on a tapped hole, the tighter tolerance H₂ hole had improved breakaway strength over the H₄ hole. However, some of this effect may be attributable to the tighter fit. Application method has the greatest effect of the factors examined. Application of Loctite® 242 to both threaded surfaces (male and female) appears to be necessary to allow adequate coverage. Short term humidity exposure during and after cure has no effect on breakloose strength when Loctite® 242 has adequate coverage by application to both fastener and insert. This study finds that the greatest effect on breakaway strength results from contamination, poor application, and humidity on an inadequately coated fastener. To insure the best breakaway strength, the fastener and

	NASA Engineering and Safety Center Technical Assessment Report	Document #:	Version:
		NESC-RP-04-092	1.0
Title: Evaluate the Performance of Loctite® as a Secondary Locking Feature for ISS Fasteners		Page #: 34 of 205	

insert surfaces should be cleaned, chemically activated, and both female and male threads should be covered with Loctite® 242.

7.6 Coefficient of Thermal Expansion (CTE) Effects of Fastener Mechanical Loading with Dissimilar Materials

The effect of temperature change on a preloaded joint depends on CTE differences between the fastener and the clamped or grip material. The larger the CTE difference, the greater the corresponding effect on fastener preload.

In elevated temperature extremes, an aluminum structure (grip) will expand more than a stainless steel fastener. This creates additional tension and preload. This situation could result in exceeding the fastener yield strength and/or possible damage to the threaded connection (e.g., thread shear tear-out).

Similarly, in low temperature extremes, the aluminum structure (grip) will shrink more than the stainless steel fastener. The result is a reduction in preload and possible gapping or joint separation under applied loading.

Preload alteration (gain and loss) due to temperature changes can be calculated using formula (10) from NASA TM-106934:

$$P_{th} = ((K_b K_j) / (K_b + K_j)) L \Delta T (\alpha_j - \alpha_b)$$

Where:

- P_{th} = axial bolt load due to thermal effects, lb
- K_b = bolt stiffness, lb/in
- K_j = joint stiffness, lb/in
- L = clamped thickness, in
- ΔT = change in temperature, °F
- α_j = abutment coefficient of thermal expansion, in/in/°F
- α_b = bolt coefficient of thermal expansion, in/in/°F

The calculated effect of temperature change for the preloaded joint configuration used for thermal vacuum testing using various combinations of materials is provided in Appendix D. An example of the CTE effect calculated using the formula above is shown below.

Based on use of 0.500-28, A286 (85 ksi) stainless steel fasteners with the following properties:

- An effective clamping or grip length of 1.75 inch into 6061 T6 aluminum.
- CTE = 9×10^{-6} in/in/°F for A286 stainless steel and 13×10^{-6} in/in/°F for 6061 T6 aluminum.

	NASA Engineering and Safety Center Technical Assessment Report	Document #: NESC-RP-04-092	Version: 1.0
Title: Evaluate the Performance of Loctite® as a Secondary Locking Feature for ISS Fasteners			Page #: 35 of 205

Assuming preload application at 70 °F and temperature transients between -50 and to +150 °F, the preload gain and loss was calculated using formula (10) from NASA TM-106943 as follows:

For a cool down from 70 to -50 °F, the aluminum grip length of 1.75 inch would shrink more than stainless steel fasteners resulting in approximately 1,600 pound loss in preload.

For heat up from 70 to +150 °F, the resulting preload change is approximately 1,000 pound increase.

If the joint is initially applied using a Johnson’s two-thirds yield preload (assuming 85 ksi yield fasteners), then the preload clamping force at 70 °F would be about 9,000 pounds for a 0.500-28 fastener. If the estimated CTE change is applied to the predicted preload, the effective preload is:

$$\text{Cool-down Preload (pounds)} = 9,000 - 1,600 = 7,400$$

$$\text{Heat-Up Preload (pounds)} = 9,000 + 1,000 = 10,000$$

The estimated preload variances are based on fastener and structure being at the same initial and final temperature. Any mismatch during the temperature transients would also affect the preload, but to a lesser degree.

In summary, temperature effects must be considered when determining acceptable installation preloads for joints.

7.7 Phase II Environmental Testing

7.7.1 NASM 1312-7 Vibration Testing

Vibration testing was conducted to evaluate the use of Loctite® 242 and 271 as a secondary locking feature in threaded fastening systems. Testing was conducted in accordance with Langley Research Center (LaRC) Test Plan LaRC-D210-01, dated February 1, 2006, except that the test matrix was expanded as initial test results were generated. Test Plan LaRC-D210-01 is included as Appendix E. Vibration testing was conducted in accordance with the NASM 1312-7.

The NASM 1312-7 standard provides a means of qualification through accelerated vibration testing. The method incorporates the use of repeated or cyclic shocks to assess a fastener locking system. The times to failure were determined as a result of this testing. Failure was defined as relative angular movement of the bolt in relation to the “nut” in the fastener system. In some instances, the measurement of the post-test breakloose torque was also measured as a secondary factor.

Four fastening systems and three fastener sizes were tested (Table 7.7-1). The fastening systems were:



NASA Engineering and Safety Center Technical Assessment Report

Document #:
NESC-RP-04-092

Version:
1.0

Title:

Evaluate the Performance of Loctite® as a Secondary Locking Feature for ISS Fasteners

Page #:
36 of 205

1. Bolt/threaded hole
2. Bolt/Heli-coil® insert (non-locking)
3. Bolt/key-locking insert (non-locking)
4. Bolt/Heli-coil® insert (locking)

Fastener sizes tested were 0.164-32, 0.250-28, and 0.500-20. Installation torque values for vibration testing for the 0.500 and 0.250 inch fasteners conformed to Military Detailed Specification (MIL-DTL)-18240F, Detail Specification, Fastener Element, Self-Locking, Threaded Fastener, 250°F. The torque value for the 0.164 inch fastener was derived by extrapolating the seating torque values in MIL-DTL-18640F. MIL-DTL-18640F defines the requirements for self-locking elements (such as non-metallic plug/pellet or strip features, but not specifically LLCs) for use in externally threaded fasteners

Table 7.7-1. NASM 1312-7 Test Matrix.

Configuration Designation	Number of Samples	Fastener Size	Insert/Hole Specification	Substrate	Locking Detail	Thread Lubricant	Head Lubricant	Avg. Torque (in-lb)	Avg. FRT (in-lb)
1	142	1/4-28	NASM124696 Helical Coil 1.5 Dia	15-5 PH 1025 SS	Loctite 242	Loctite 242	None	59.1	
2	41	1/4-28	MS51831CA202L Key-Locking 1.5 Dia	15-5 PH 1025 SS	Loctite 242	Loctite 242	None	60	
3	43	1/4-28	H4 class 3 tapped hole, 1.5 Dia	A286	Loctite 242	Loctite 242	None	60	
4	21	1/2-20	NASM124700 Helical Coil 1.5 Dia	15-5 PH 1025 SS	Loctite 271	Loctite 271	None	300	
5	35	1/2-20	H4 class 3 tapped hole, 1.5 Dia	A286	Loctite 271	Loctite 271	None	300	
6	54	.164-32	NASM122119 Helical Coil 1.5 Dia	15-5 PH 1025 SS	Loctite 242	Loctite 242	None	20	
7	18	1/4-28	NASM124696 Helical Coil 1.5 Dia	15-5 PH 1025 SS	None	Braycote	None	60	
9	55/11	1/4-28	NASM21209 F4-15 Locking Helical Coil 1.5 Dia	15-5 PH 1025 SS	Locking Helicoil	Braycote	None	60/50	14/15
10	11	1/4-28	NASM21209 F4-15 Locking Helical Coil 1.5 Dia	15-5 PH 1025 SS	Locking Helicoil	Braycote	None	176	
11	11	1/4-28	NASM124696 Helical Coil 1.5 Dia	15-5 PH 1025 SS	None	Braycote	None	140	
13	8/8/6	1/4-28	NASM124696 Helical Coil 1.5 Dia	15-5 PH 1025 SS	None	Braycote	None	84/105/126	
14	11	1/4-28	NASM124696 Helical Coil 1.5 Dia	15-5 PH 1025 SS	None	Braycote	None	126	
15	11	1/4-28	NASM124696 Helical Coil 1.5 Dia	15-5 PH 1025 SS	None	Braycote	None	105	
17	11	1/4-28	NASM124696 Helical Coil 1.5 Dia	15-5 PH 1025 SS	None	Braycote	Braycote	84	
18	11	1/4-28	NASM124696 Helical Coil 1.5 Dia	15-5 PH 1025 SS	None	Braycote	Braycote	105	
19	11	1/4-28	NASM124696 Helical Coil 1.5 Dia	15-5 PH 1025 SS	None	Braycote	Braycote	126	
20	22	1/4-28	NASM124696 Helical Coil 1.5 Dia	15-5 PH 1025 SS	None	Braycote	Braycote	105	
21	33	1/4-28	NASM21209 F4-15 Locking Helical Coil 1.5 Dia	15-5 PH 1025 SS	Locking Helicoil	Braycote	Braycote	105	17
22	33	1/4-28	NASM124696 Helical Coil 1.5 Dia	15-5 PH 1025 SS	Loctite 242	Loctite 242	Braycote	105	
23	11	1/4-28	NASM21209 F4-15 Locking Helical Coil 1.5 Dia	15-5 PH 1025 SS	Locking Helicoil	Braycote	Braycote	115	20



**NASA Engineering and Safety Center
Technical Assessment Report**

Document #:
**NESC-RP-
04-092**

Version:
1.0

Title:

**Evaluate the Performance of Loctite® as a Secondary
Locking Feature for ISS Fasteners**

Page #:
37 of 205

Table 7.7-2. NASM 1312-7 0.250-28 Vibration Testing Performance

Configuration Designation	Number of Samples	Insert Type	Lubricant or thread locker	Torque (in-lbs)	Head Lubricant	Performance
6	54	Free running	Loctite® 242	20	No head lube	10 bolts > 30k cycles
1	142	Free running	Loctite® 242	60	No head lube	77 bolts > 30k cycles
2	41	Free running	Loctite® 242	60	No head lube	23 bolts > 30k cycles
3	43	Tapped Hole	Loctite® 242	60	No head lube	13 bolts > 30k cycles
22	33	Free running	Loctite® 242	105	Braycote® head lube	All bolts > 30k cycles
9	55/11	Locking	Braycote®	60/50	No head lube	12 bolts > 30k cycles
21	33	Locking	Braycote®	105	Braycote® head lube	18 bolts > 30k cycles
23	11	Locking	Braycote®	115	Braycote® head lube	All bolts > 30k cycles
10	11	Locking	Braycote®	176	No head lube	All bolts > 30k cycles
17	11	Free running	Braycote®	84	Braycote® head lube	1 bolt > 30k cycles
15	11	Free running	Braycote®	105	No head lube	7 bolts > 30k cycles
18	11	Free running	Braycote®	105	Braycote® head lube	1 bolt > 30k cycles
20	22	Free running	Braycote®	105	Braycote® head lube	Zero bolts > 30k cycles
14	11	Free running	Braycote®	126	No head lube	9 bolts > 30k cycles
19	11	Free running	Braycote®	126	Braycote® head lube	5 bolts > 30k cycles
11	11	Free running	Braycote®	140	No head lube	All bolts > 30k cycles

7.7.1.1 NASM 1312-7 Vibration Test Results

NASM 1312-7 vibration testing results are shown in Table 7.7-2. Performance was based on the number of fasteners surviving 30,000 cycles without loosening (relative angular movement) as indicated by marking of the fastener/substrate. Vibration testing performance results indicate the following:

1. The performance of Loctite® 242 in this NASM 1312-7 vibration testing was as good as or better than the performance of the free running and locking inserts tested.
2. The performance of Loctite® 242, the free running inserts, and the locking inserts appears to improve with increasing preload.

	NASA Engineering and Safety Center Technical Assessment Report	Document #: NESC-RP-04-092	Version: 1.0
Title: Evaluate the Performance of Loctite® as a Secondary Locking Feature for ISS Fasteners		Page #: 38 of 205	

7.7.2 Thermal/Vacuum Soak Testing (Hot and Cold)

7.7.2.1 Background

Simulated bolted joints using Loctite® 242 were subjected to ambient (72 °F), hot (200 °F), and cold (-140 °F) soak testing in a high vacuum environment of less than 10^{-5} torr. Testing was performed to determine the breakaway torque, and running torque from 90 to 720 degrees as a function of time at temperature and vacuum. Samples were installed into plates populated with up to 25 bolts on each plate. Hot samples were heated using radiant heating to heat and maintain the samples at 200 °F. Cold samples used a cold plate to cool and maintain the sample plates to a temperature of -140 °F. Ambient samples were installed into plates at 72 °F. The simulated joint, shown in Figure 7.7-1, used NAS1004, 0.250-28 UNJF-3A fasteners to clamp a cylinder to an aluminum base plate.

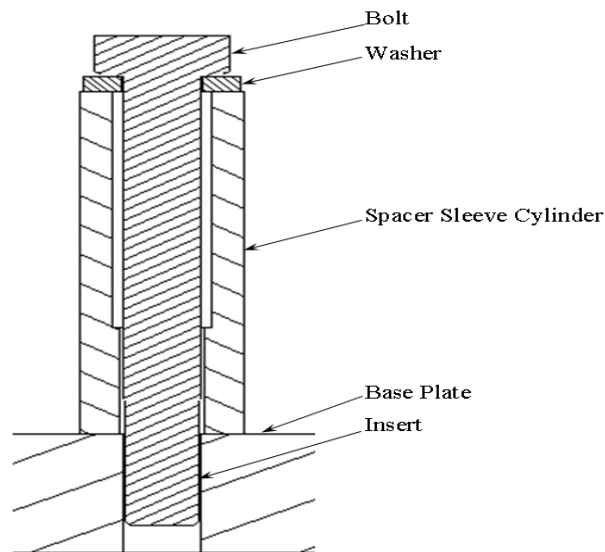

Figure 7.7-1. Simulated Joint

Three cylinder materials, shown in Table 7.7-3, were used during the testing. Testing was performed using bolts inserted into non-locking Heli-coil® inserts with no preload (finger-tight) applied.

	NASA Engineering and Safety Center Technical Assessment Report	Document #:	Version:
		NESC-RP-04-092	1.0
Title: Evaluate the Performance of Loctite® as a Secondary Locking Feature for ISS Fasteners			Page #: 39 of 205

Table 7.7-3. Simulated Joint Test Matrix and Loading Conditions

Bolt	Insert	Cylinder Material	Initial Preload (lbs)
NAS1004-22	MS124696	Al 6061-T6	0
NAS1004-22	MS124696	A286	0
NAS1004-22	MS124696	15-5 PH	0

Thermal vacuum chambers were loaded and held at ambient, hot, or cold temperatures for specified periods of time. At the end of specified times, plates were removed from the chambers. For the hot and cold plates, the chambers were brought to ambient conditions and one plate was removed. The chambers were then reheated or cooled to the designated temperature and held. This process was performed until all the plates had been removed from the chambers.

Table 7.7-4 shows the ambient, hot and cold plate removal times in hours from the chambers.

Table 7.7-4. Ambient, Hot and Cold Plate Removal Times in Hours

Plate Number	Ambient (72 °F) Plates Removal Time (hrs)	Hot (200 °F) Plates Removal Time (hrs)	Cold (-140 °F) Plates Removal Time (hrs)
1	48	215	263
2	192	383	451
3	384	479	553
4	480	575	619
5	576	670	715
6	672	768	811
7	768	862	907
8	864	1000	1005
9	960	1054	1099
10	1056	1174	1197

7.7.2.2 Results

The breakloose torque measurements of fasteners installed with Loctite® 242 and soaked at three temperatures for several exposure times were analyzed. Statistical inference shows the means of the data groups are not equal. However, descriptive analysis of the data suggests the factors of exposure time and exposure temperature are likely not the cause of unequal means. Different sleeve materials produced no measureable difference in breakloose torques. Therefore, all rows of data were combined into one set regardless of sleeve material.

	NASA Engineering and Safety Center Technical Assessment Report	Document #: NESC-RP-04-092	Version: 1.0
Title: Evaluate the Performance of Loctite® as a Secondary Locking Feature for ISS Fasteners			Page #: 40 of 205

7.7.2.2.1 Inference Statistics, Exposure Time

ANOVA was performed to test the hypothesis of equal means on two or more groups of data. Assumptions of the ANOVA include independence, normality, and equality of variance. The assumption of independence is valid in this case as any given measurement or data set should have no effect on another measurement (i.e., independent bolts) or data set (i.e., exposure time and temperature). Normality tests on each exposure time suggest the data are not normally distributed. Levene's test² suggests variances are equal in the hot data, but unequal in the ambient and cold data. Although the assumptions are violated, ANOVA is often assumed robust against departures from normality when the sample sizes are equal. ANOVA performed on each temperature set suggest the means of each data set are not equal (Figures 7.7-2a and 7.7-2b). Sample sizes are not equal on the ambient tests. A nonparametric test³ used when the normality assumption is violated, indicated medians are not equal. ANOVA is included in Figure 7.7-2c to display the descriptive summary statistics.

One issue with the above inference is that it assumes the only factors evaluated within the temperature sets are exposure time. Since complete cure should occur before the first measurement in the ambient tests, these data should be considered a control group. It is apparent there is another factor influencing the breakloose torque within each group as all groups should have equal means and variances.

7.7.2.2.2 Inference Statistics, Temperature

If the assumption that exposure time is not a factor in the breakloose torque values and pools all data within each temperature group, then a comparison between temperatures can be made. It was determined that data are not normally distributed. A Kruskal-Wallis test concludes that the medians of the three temperature exposures are not equal. The ANOVA results (included for detailed summary statistics) are shown in Figure 7.7-3.

7.7.2.2.3 Exploratory Data Analysis (EDA)

EDA methods are used primarily to explore data before using more traditional methods, and are a useful method to visually identify unique features contained within the data. A dotplot of the data is useful in examining the data scatter and range. From Figure 7.7-4a it is seen that the variance within each group is large, in some cases the coefficient of variation is as high as 25 percent. Figure 7.7-4a and 7.7-4b display the conclusion from the ANOVA that the means for the groups are not equal.

² Levene, H., "Robust Tests for the Equality of Variances", Contributions to Probability and Statistics, ed. I. Olkin, Palo Alto, CA: Stanford University Press, 1960.

³ Kruskal-Wallis (ref. 2, Conover, W.J., *Practical Nonparametric Statistics*, 3rd Edition, John Wiley and Sons, (1999) pp. 288-297.)



**NASA Engineering and Safety Center
Technical Assessment Report**

Document #:
**NESC-RP-
04-092**

Version:
1.0

Title:

**Evaluate the Performance of Loctite® as a Secondary
Locking Feature for ISS Fasteners**

Page #:
41 of 205

7.7.2.2.4 Conclusions

A statistically significant difference means there is statistical evidence of a difference at a specific significance level. It does not indicate that the difference is important (or physically significant in the general meaning of the word). The high variance and unexplained differences in means within each temperature group suggest there is another factor affecting the breakloose torque. The EDA graphical representations illustrate that exposure time is unlikely the cause of dissimilar means. Exposure temperature may have an effect. The purpose of Loctite® 242 is not to increase breakloose torque, but to maintain adequate preload in the presence of vibration. Breakloose torque may not be the appropriate metric to evaluate the effectiveness of Loctite® 242, and to assess the affect of factors such as exposure time at temperature. While the breakloose torque may be affected by temperature that does not necessarily correlate to conclusions regarding the effectiveness of Loctite® 242 as a secondary locking feature.

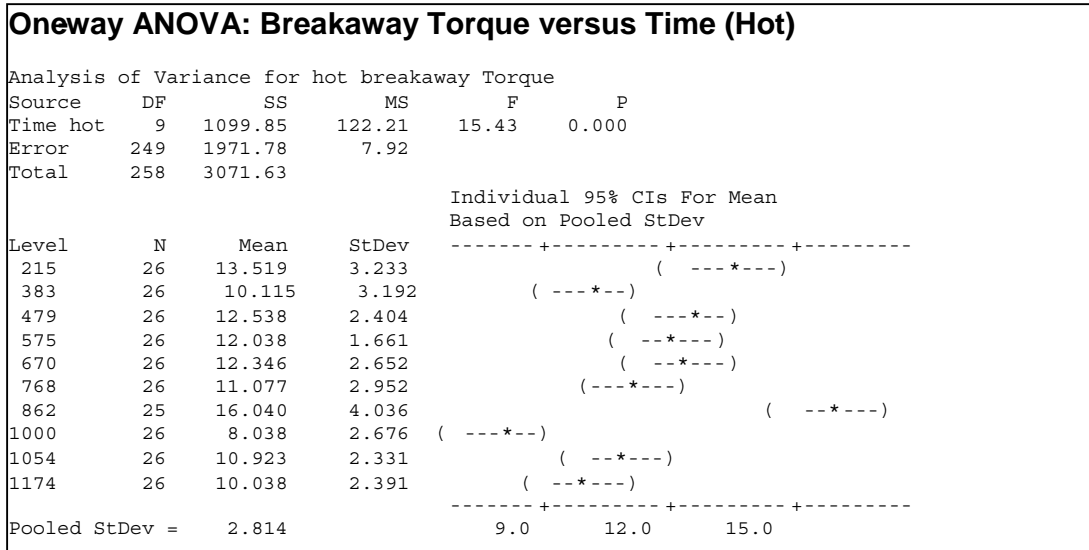

Figure 7.7-2a. ANOVA on Breakloose Torque versus Exposure Time (200 °F hot case)



NASA Engineering and Safety Center Technical Assessment Report

Document #:
**NESC-RP-
04-092**

Version:
1.0

Title:

Evaluate the Performance of Loctite® as a Secondary Locking Feature for ISS Fasteners

Page #:
42 of 205

Oneway ANOVA: Breakaway Torque versus Time (Cold)

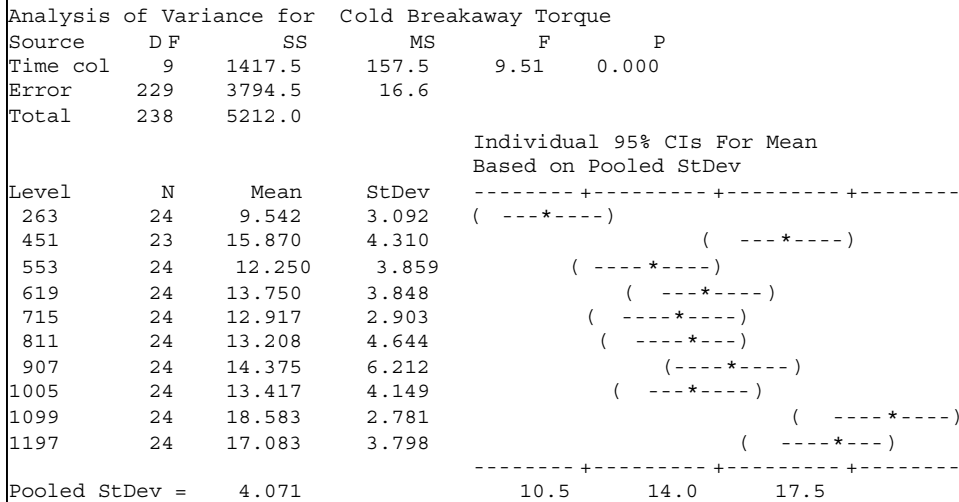

Figure 7.7-2b. ANOVA on Breakaway Torque versus Exposure Time (-140 °F cold case)

Oneway ANOVA Breakaway Torque versus Time (ambient)

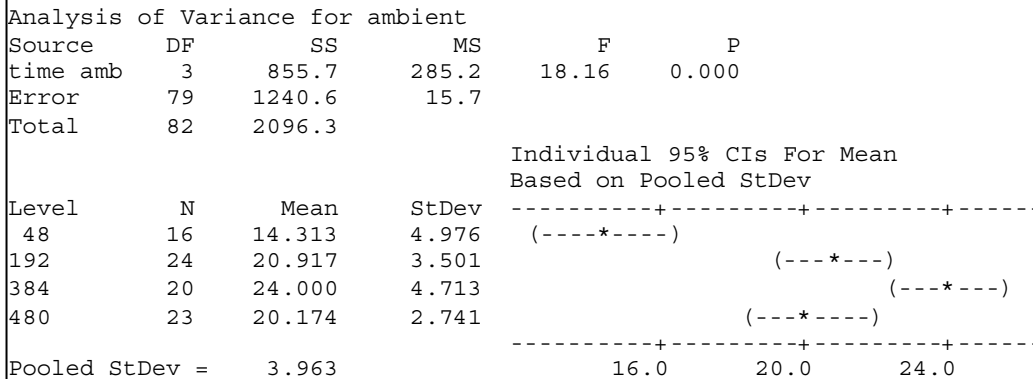

Figure 7.7-2c. ANOVA on Breakloose Torque versus Exposure Time (72 °F ambient case)



NASA Engineering and Safety Center Technical Assessment Report

Document #:
**NESC-RP-
04-092**

Version:
1.0

Title:

Evaluate the Performance of Loctite® as a Secondary Locking Feature for ISS Fasteners

Page #:
43 of 205

Oneway ANOVA: Breakaway Torque versus Temperature

Analysis of Variance

Source	DF	SS	MS	F	P
Factor	2	4578.7	2289.4	127.47	0.000
Error	579	10398.7	18.0		
Total	581	14977.5			

Individual 95% CIs For Mean
Based on Pooled StDev

Level	N	Mean	StDev
hot	260	11.667	3.454
cold	239	14.092	4.680
ambient	83	20.181	5.056

Pooled StDev = 4.238

Figure 7.7-3. ANOVA on Breakaway Torque versus Temperature

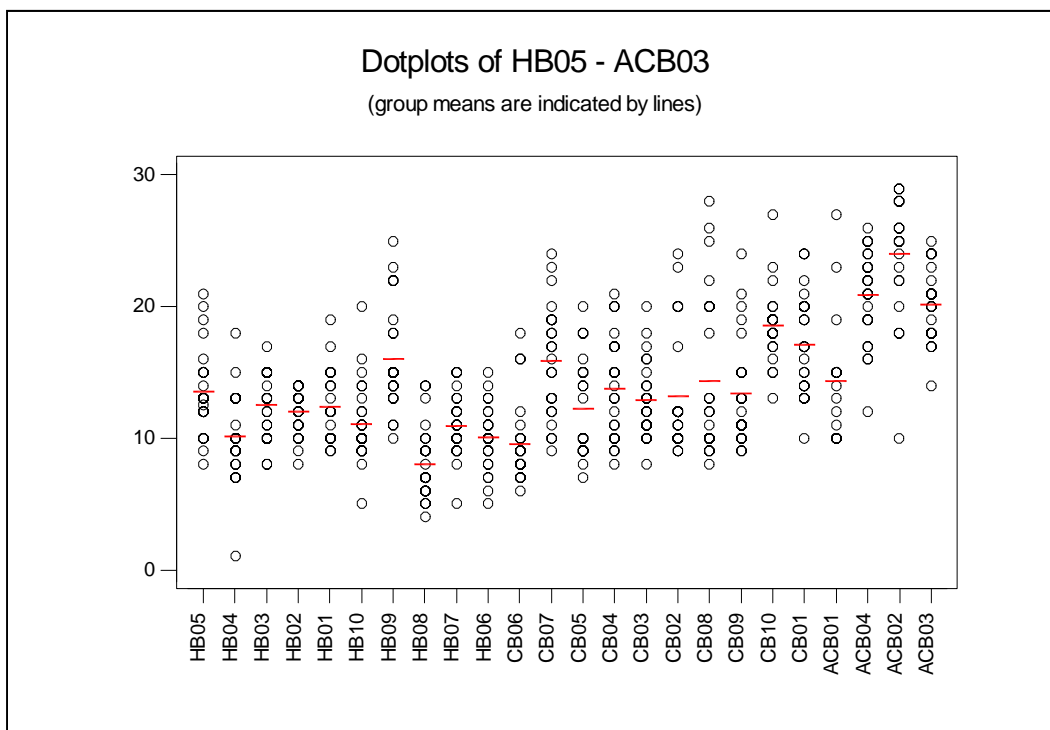

Figure 7.7-4a. Dotplot of Torque versus Test Series



Title:

**Evaluate the Performance of Loctite® as a Secondary
Locking Feature for ISS Fasteners**

Page #:
44 of 205

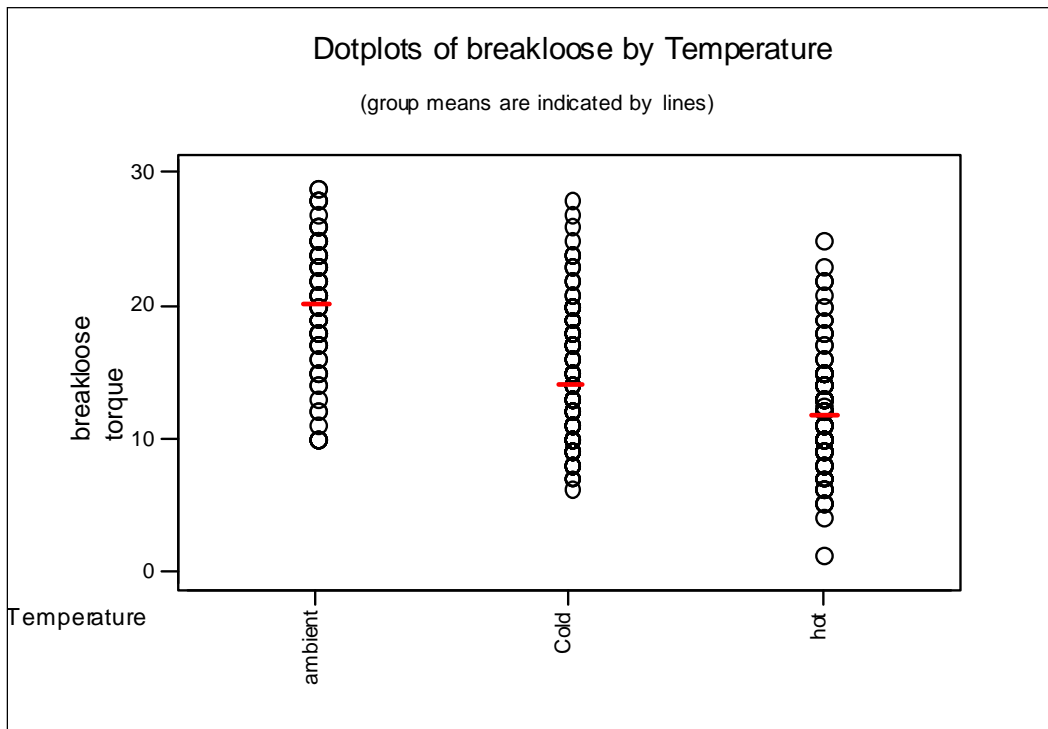



Figure 7.7-4b. Dotplot of Torque versus Exposure Temperature

7.7.3 Junker Testing

A study of the loosening resistance of threaded fasteners subjected to dynamic shear was performed. A series of tests were performed to provide a comparative assessment of the locking performance (or loosening resistance) of NAS1004-28 UNJF-3A hex head screws with:

1. Standard free-running Helicoil® inserts with Braycote® 601 lubricant.
2. Locking Helicoil® inserts with Braycote® 601 lubricant.
3. Standard free-running Helicoil® inserts with Loctite® 242.

The tests were performed on a Deutsches Institut für Normung (DIN) 65151 or Junker type test machine, which provides dynamic shear loading. Twelve tests were performed for each locking level. The selected test-machine parameters provides significant loosening with the “standard” Helicoil® insert with Braycote® 601 lubricant configuration over a finite number of cycles, without causing screws to break for any of the locking levels, so that the performance of the secondary locking features can be compared. The tests were performed with the test machine at 15Hz with a 0.12 inch eccentric, preload at 66 percent yield or 2,400 pounds, and a record length of 2,400 cycles. The percent loss of preload was determined after 2,300 cycles for each test run.

	NASA Engineering and Safety Center Technical Assessment Report	Document #: NESC-RP-04-092	Version: 1.0
Title: Evaluate the Performance of Loctite® as a Secondary Locking Feature for ISS Fasteners		Page #: 45 of 205	

7.7.3.1 Conclusions

The data and analyses showed that for the conditions tested:

1. The Standard Helicoil® insert with Loctite® 242 on average provides better locking performance than the Locking Heli-coil® insert with Braycote® 601 lubricant and the Standard Helicoil® insert with Braycote® 601 lubricant.
2. The Standard Helicoil® insert with Braycote® lubricant on average has the worse locking performance of the three configurations tested.

7.7.4 Thermal/Vacuum Cyclic Testing

The NESC conducted some limited thermal vacuum cyclic testing as part of the investigation into the use of anaerobic locking compounds in fastening systems. The “Loctite® Investigation Thermal Vacuum Cycling Testing” test plan, dated February 9, 2007, and test results are provided in Appendix G.

Simulated bolted joints using Loctite® threadlocker were subjected to thermal cycling in a high vacuum environment. The breakloose torque, prevailing torque, as a function of time, were recorded post exposure to thermal/vacuum cycling.

The simulated joint, very similar to that shown in Figure 7.1-1, used NAS1004, ¼-28 UNJF-3A bolts to clamp a cylinder to an aluminum base plate. The cylinder materials, aluminum 6061-T6, A286, and 15-5 PH were chosen to provide either a CTE null temperature effect or a CTE thermal load of approximately ±1000 pounds in the joint. Bolts were installed into various base plates containing twenty five simulated fastener joints with Loctite® 242 used as the thread locker. Each plate contained ten (10) aluminum cylinders, ten (10) A286 cylinders, and five (5) 15-5 PH cylinders. Bolts were torqued to produce an initial preload of approximately 650 pounds force based on a portion of the fasteners being installed with instrumented bolt (joints with aluminum cylinders were torque to an average 50 inch-pounds and the joints with stainless cylinders were torques to an average of 45 inch pounds torque). Thermal cycling was performed in a high vacuum (10^{-5} torr) environment between ±100°C.

The approximate thermal cycle used is shown in Figure 7.7-5, and the test plate removal schedule is shown in Figure 7.7-6.



Title:

Evaluate the Performance of Loctite® as a Secondary
Locking Feature for ISS Fasteners

Page #:
46 of 205

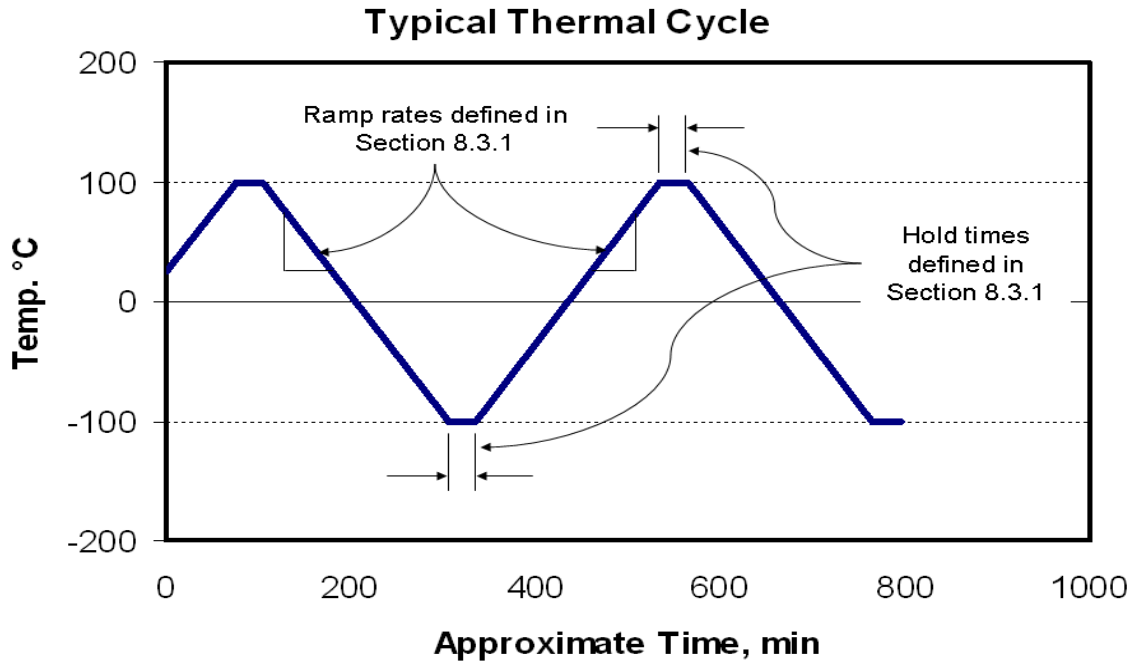

Figure 7.7-5. Thermal Cycle Profile

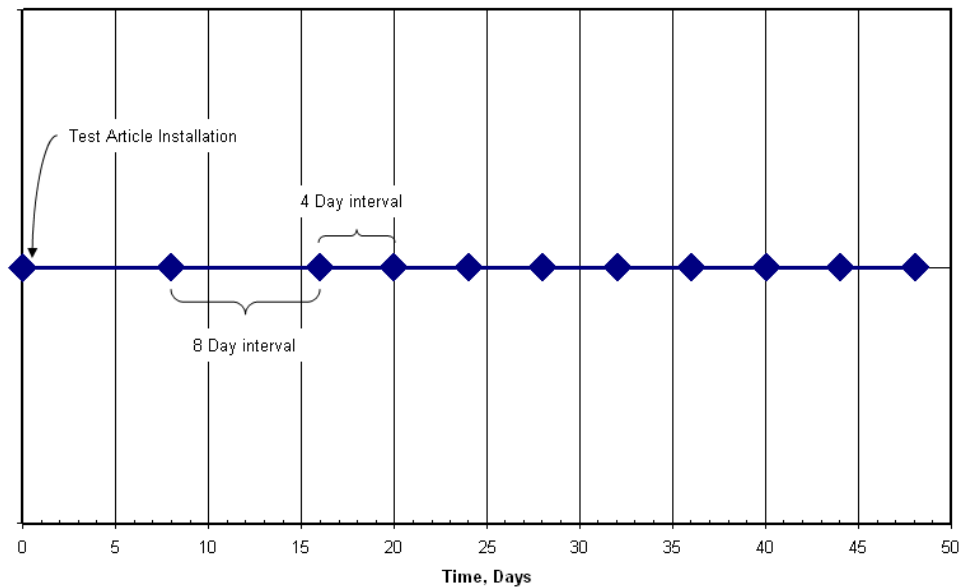

Figure 7.7-6. Test Article Removal Schedule



**NASA Engineering and Safety Center
Technical Assessment Report**

Document #:
NESC-RP-04-092

Version:
1.0

Title:

**Evaluate the Performance of Loctite® as a Secondary
Locking Feature for ISS Fasteners**

Page #:
47 of 205

At specified time intervals, a test plate was removed from the thermal/vacuum environment. Breakloose and running torque results are shown in Table 7.7-5.

Table 7.7-5. Breakloose and Running Torque Results for Thermal Vacuum Cyclic Testing of Preloaded Fasteners plus Loctite® with aluminum and Stainless Steel Cylinders

Test Plate Number (order of removal from chamber)	2	1	3	4	5	6	7	8	9	10
Total time in Chamber (hours)	192	384	480	576	648	768	816	912	1008	1104
Number of thermal cycles	18	42	55	69	83	91	103	116	130	142
Avg. Installation Torque (Aluminum Cylinders)	50	50	50	50	50	50	50	50	50	50
Avg. Installation Torque (Stainless cylinders)	45	45	45	45	45	45	45	45	45	45
Avg. Breakloose torque (in-lbs)	57.1	48.8	51.4	50.7	52.7	51.6	52.5	55.3	53.9	52.8
Avg. Breakloose torque Standard Deviation (in-lb)	4.6	9.6	4.8	4.4	3.4	4.5	5.0	3.9	4.2	3.6
Avg. Running Torque for 2 Complete Rotations (in-lb)	15.7	14.7	14.2	14.0	11.0	8.9	8.2	9.8	8.9	9.2
Avg. Running torque StDev for 2 Complete Rotations (in-lb)	3.0	3.7	2.7	2.3	4.4	2.0	2.2	1.8	2.2	1.8
Avg. Running Torque for 1 st Rotation Only (in-lb)	18.5	17.4	16.7	16.8	12.5	10.2	10.1	11.4	10.7	11.4
Avg. Running Torque StDev for 1 st Rotation Only (in-lb)	3.8	4.4	2.7	2.3	4.9	2.6	2.6	2.3	2.8	2.3
Avg. Running Torque for 2 nd Rotation Only (in-lb)	12.9	11.9	11.7	11.2	9.5	7.5	6.3	8.2	7.1	7.1
Avg. Running Torque StDev for 2 nd Rotation Only (in-lb)	2.1	3.0	2.6	2.4	3.8	1.5	1.9	1.4	1.6	1.3

Results: The breakloose torques were similar to the installation torques. There appears to be no effect of thermal cycling between minus 100°C and 100°C in a high vacuum environment of 10⁻⁵ torr over time on the performance of Loctite® as a thread locker for the number of thermal cycles tested.

7.8 Human Factors review of Application Process for LLCs in ISS Hardware

Loctite® is an LLC, although there are other brands of LLC's. "LLC" and the trade name "Loctite®" are used interchangeably. The three standards below were reviewed and inconsistencies/incongruities among the standards assessed, including descriptions of activators/primers, cure time and the activator/primers, activator/primers and inactive metals, and the application of LLCs on fastening hardware. Current information obtained from the Loctite® manufacturer regarding certain application features was also assessed. Details of the review are included as Appendix H.

MIL-S-22473E "Military Specification: Sealing, Locking, and Retaining Compounds: (Single Component)" (dated 12 Apr 1983, and cancelled 21 Jan 2004)

MIL-S-46163A "Military Specification: Sealing, Lubricating and Wicking Compounds: Thread-Locking, Anaerobic, Single-Component" (dated 12 Jul 1983, and inactivated for new design 23 Mar 2001)

ASTM D5363-03 "Standard Specification for Anaerobic Single-Component Adhesives (AN)" (dated Dec. 2003, and corrected Aug 2006)

	NASA Engineering and Safety Center Technical Assessment Report	Document #: NESC-RP-04-092	Version: 1.0
Title: Evaluate the Performance of Loctite® as a Secondary Locking Feature for ISS Fasteners			Page #: 48 of 205

7.9 Loctite® Application Process Comparison

The standards listed below were reviewed relative to their use for the application of LLCs to flight hardware. The review included; (1) how activator/primer is described in the documents, (2) a comparison of the documents, (3) how LLC's are described in the documents, and, (4) results of field observations of applying Loctite® during ISS rework operations. Details of the review are included as Appendix I.

1. Boeing Document BAC 5011, "Application of Retaining Compounds" (Dec-86)
2. Boeing Document Dwg. 683-13000 "Hatch Assembly" (May, 2005)
3. Lockheed Martin (Michoud Oprs) Document STP 2009B, "Locking and Sealing Compounds, Application of" (Sep-04)
4. Rockwell Document MA0106-333, "Application of Locking and Retaining Compound to Threaded Electrical, Hardware and Mechanical Fasteners" (Dec-85)
5. Boeing Huntington Beach Document MA0106-333, "Application of Locking and Retaining Compound to Threaded Electrical, Hardware and Mechanical Fasteners" (Apr-04)

7.10 Literature Review

A literature review (see Appendix J) was performed which provides an overview on the self-loosening of threaded fasteners, which specifically includes bolted joints. The review includes a brief chronological overview of research reports related to the self-loosening of fasteners due to vibration. Then a summary of parameters that have been identified by the authors of the research articles are summarized and followed by a section which presents a brief overview of some testing machines that have been used. This literature review was organized to be only a review of the topic, and details on any of the testing and research that was conducted may be found in the original articles that are identified in Section 14.0.

7.11 Questions/Discussions with Henkel Loctite®

In summary, this question/answer exchange proved to be valuable in helping the team's understanding of Loctite® threadlockers and provided clarification information for numerous company procedure documents that the team evaluated. The information provided in Appendix B is as received and unedited so that the information provided by Henkel Loctite® was not changed.

	NASA Engineering and Safety Center Technical Assessment Report	Document #: NESC-RP-04-092	Version: 1.0
Title: Evaluate the Performance of Loctite® as a Secondary Locking Feature for ISS Fasteners		Page #: 49 of 205	

8.0 Observations, Findings, and NESC Recommendations

The findings, observations, and recommendations provided in this investigation apply to the anaerobic LLCs Loctite® 242 and 271. No other anaerobic LLCs were evaluated for this investigation.

8.1 Observations

The following observations were identified:

- O-1.** Higher preloads help to resist vibration loosening regardless of the type of locking feature (e.g., LLC, prevailing torque type, or none) tested.
- O-2.** Loctite® 242 and 271 contribute to prevent loosening (Phase zero testing).
- O-3.** Preload level has no effect on the breakaway strength of fully cured Loctite® 242 and 271 (zero load wedge testing).
- O-4.** Breakaway strength is affected by hole type, being lower in blind holes than in thru holes (zero load wedge testing).
- O-5.** LLC cure time is longer for blind holes than for thru holes.
- O-6.** Breakaway strength was higher when the fastening system hardware surfaces were adequately cleaned, chemically activated, and both female and male threads were sufficiently coated with the anaerobic LLC.
- O-7.** Using a Junkers test, a standard Heli-coil® insert with Loctite® 242 provided better locking performance than a locking Heli-coil® insert with Braycote® 601 lubricant.
- O-8.** LLCs will take significantly longer to fully cure and the timeframe is highly unpredictable when no activator is used on inactive/less active metals like stainless and titanium.
- O-9.** Humidity has no effect on breakaway strength when LLCs are applied to both female and male substrate surfaces.

8.2 Findings

The following findings were identified:

- F-1.** Loctite® 242 and 271 provide resistance to vibration loosening at least as good as that provided by prevailing torque type locking inserts.

	NASA Engineering and Safety Center Technical Assessment Report	Document #: NESC-RP-04-092	Version: 1.0
Title: Evaluate the Performance of Loctite® as a Secondary Locking Feature for ISS Fasteners		Page #: 50 of 205	

- F-2.** Military and industry specifications regarding LLCs are inconsistent and somewhat contradictory in their treatment of LLCs. Proper application processes must be developed for using LLCs.
- F-3.** Factors that improve cure of LLCs include: substrate cleanliness, proper surface activation, tighter thread class, use of thru hole instead of blind hole, and application of sufficient LLC to both the female and male substrate surfaces to eliminate all air in thread gap.
- F-4.** Loctite® breakloose torque performance is degraded when used over fastening system hardware with DFL coatings applied.

8.3 NESC Recommendations

NESC recommendations to the NASA engineering community for the use of the specific anaerobic liquid locking compounds addressed in this report follow:

- R-1.** Accept Loctite® 242 and 271 for use as a secondary locking feature for ISS hardware when application processes that produce sufficient cure for the substrates to which they are applied have been developed. (*F-1, F-2, and F-4*)
- R-2.** Develop LLC application processes that produce sufficient cure of the LLC for the substrates to which applied. (*F-2*)
 - a. Develop procedures and tests that verify sufficient cure of the LLCs. (*F-2*)
 - b. Prevent contamination of LLCs prior to, during and after application processes. (*F-3*)
 - c. Use activators on inactive/less active substrates (e.g., stainless steel, titanium) and apply to both female and male fastening system components. (*F-3*)
 - d. Determine the torque-tension behavior of fastening system hardware that will use LLCs. The torque-tension behavior should be characterized to load levels greater than those required for fastener installation (e.g., typically 50-75% of the load carrying capability of the fastener in pounds). (*F-2*)
 - e. LLCs shall be applied to both the female and male threaded surfaces during application processes. (*F-3*)
 - f. Clean and activate female and male substrate surfaces prior to applying LLCs. (*F-3*)

	NASA Engineering and Safety Center Technical Assessment Report	Document #: NESC-RP-04-092	Version: 1.0
Title: Evaluate the Performance of Loctite® as a Secondary Locking Feature for ISS Fasteners		Page #: 51 of 205	

g. Do not use LLCs on hardware that has dry film lubrication applied to either female or male threaded surfaces. (*F-4*)

R-3. NASA Office of the Chief Engineer should revise NASA-STD-6016 Standard Materials and Processes Requirements for Spacecraft Section 4.2.6.5.1 Liquid Locking Compound to reflect the data and conclusions of this report. (*All Findings*)

9.0 Alternate Viewpoints

It may be that some alternative viewpoints exist; however, no alternative viewpoints were reported to the NESC team or by NESC team members for incorporation into this report.

10.0 Other Deliverables

There are no other deliverables for this effort.

11.0 Lessons Learned

LL-1. When Loctite® cures sufficiently, it provides secondary locking of threaded fasteners at least as good as prevailing torque locking fasteners.

LL-2. Loctite® should be applied to both male and female threads in sufficient quantity to eliminate air in the thread gap (cure depends on absence of oxygen).

LL-3. Activator / primer should be used prior to application of Loctite® threadlocker (improves cure and reduces cure time when used with non-active thread material).

LL-4. Threaded surfaces should be cleaned of grease and contaminants before application of Loctite® activator / primer and Loctite® threadlocker.

LL-5. Loctite® should not be used with fastener threads coated with DFL.

LL-6. Loctite® cure time is longer when used with blind holes than with thru holes.

LL-7. Tighter hole tolerance improves Loctite® breakaway torque.

LL-8. Loctite® cure is not a function of preload.

	NASA Engineering and Safety Center Technical Assessment Report	Document #: NESC-RP- 04-092	Version: 1.0
Title: Evaluate the Performance of Loctite® as a Secondary Locking Feature for ISS Fasteners		Page #: 52 of 205	

12.0 Definition of Terms

Corrective Actions

Changes to design processes, work instructions, workmanship practices, training, inspections, tests, procedures, specifications, drawings, tools, equipment, facilities, resources, or material that result in preventing, minimizing, or limiting the potential for recurrence of a problem.

Finding

A conclusion based on facts established by the investigating authority.

Lessons Learned

Knowledge or understanding gained by experience. The experience may be positive, as in a successful test or mission, or negative, as in a mishap or failure. A lesson must be significant in that it has real or assumed impact on operations; valid in that it is factually and technically correct; and applicable in that it identifies a specific design, process, or decision that reduces or limits the potential for failures and mishaps, or reinforces a positive result.

Observation

A factor, event, or circumstance identified during the assessment that did not contribute to the problem, but if left uncorrected has the potential to cause a mishap, injury, or increase the severity should a mishap occur. Alternatively, an observation could be a positive acknowledgement of a Center/Program/Project/Organization's operational structure, tools, and/or support provided.

Problem

The subject of the independent technical assessment/inspection.

Proximate Cause

The event(s) that occurred, including any condition(s) that existed immediately before the undesired outcome, directly resulted in its occurrence and, if eliminated or modified, would have prevented the undesired outcome.

Recommendation

An action identified by the assessment team to correct a root cause or deficiency identified during the investigation. The recommendations may be used by the responsible Center/Program/Project/Organization in the preparation of a corrective action plan.

	NASA Engineering and Safety Center Technical Assessment Report	Document #: NESC-RP-04-092	Version: 1.0
Title: Evaluate the Performance of Loctite® as a Secondary Locking Feature for ISS Fasteners		Page #: 53 of 205	

Root Cause

One of multiple factors (events, conditions, or organizational factors) that contributed to, or created the proximate cause and subsequent undesired outcome and, if eliminated or modified, would have prevented the undesired outcome. Typically, multiple root causes contribute to an undesired outcome.

13.0 Acronyms List

ALMA	Aerospace Locknut Manufacturers Association
ANSI	American National Standards Institute
ARC	Ames Research Center
ASTM	American Society for Testing and Materials
ATK	Alliance Techsystems, Inc.
CTE	Coefficient of Thermal Expansion
DFL	Dry Film Lubricated
DIN	Deutsches Institut für Normung
ESNA	Elastic Stop Nut Corporation of America
ESP	External Stowage Platform
ESPAD	External Stowage Platform Attachment Device
EVA	ExtraVehicular Activity
FRAM	Flight Release Attachment Mechanism
GSFC	Goddard Space Flight Center
ICC	Integrated Cargo Carrier
ISS	International Space Station
JSC	Johnson Space Center
KSC	Kennedy Space Center
LaRC	Langley Research Center
LLC	Liquid Locking Compound
MEK	Methyl-Ethyl-Ketone
Mil-DTL	Military Detailed Specification
Mil-S	Military Specification
MSFC	Marshall Space Flight Center
NASM	National Aerospace Standard (former Military Standard)
NESC	NASA Engineering and Safety Center
NRB	NESC Review Board
QA	Quality Assurance
TDT	Technical Discipline Team
UCP	Unpressurized Cargo Pallet

	NASA Engineering and Safety Center Technical Assessment Report	Document #: NESC-RP-04-092	Version: 1.0
Title: Evaluate the Performance of Loctite® as a Secondary Locking Feature for ISS Fasteners		Page #: 54 of 205	

14.0 References

1. Anon. "Fastener Loosening: The Causes Part I," *Assembly Engineering* 27 (2) (February 1984): pp. 16-18.
2. Basava, S. and D. P. Hess. "Bolted Joint Clamping Force Variation Due to Axial Vibration," *Journal of Vibration and Sound* 210 (2) (1998): pp. 255-265.
3. Bickford, James H. *An Introduction to the Design and Behavior of Bolted Joints*. New York and Basel: Marcel Dekker, Inc., 1990.
4. Bickford, James H. "Fastener Groups Seek Answers to Bolted-Joint Problems," *Machine Design* (July 1984): pp. 77-80.
5. Bickford, James H. "That Initial Preload – What Happens to it?" *Mechanical Engineering* 105 (10) (October 1983): pp. 57-61.
6. Bolt Science. "Bolt Science: Solutions to Bolting Problems - Vibration Loosening of Bolts and Threaded Fasteners," *Bolt Science Limited* (2006) <http://www.boltscience.com/pages/vibloose.htm>; Internet; accessed 20 Mar. 2006.
7. Charles, William J. "Use of Adhesives and Sealants on Mechanical Fasteners to Improve Performance," *Adhesives Coatings and Sealants Division, 3M UK PLC*. Bracknell, Berks Network Events (1985): pp. 165-176.
8. Chen, J-H., S-C. Hsieh, and A-C. Lee. "The Failure of Threaded Fasteners Due to Vibration," *Journal of Mechanical Engineering Science* 219 (C) (2005): pp. 299-314.
9. Crane, Ryan. American Society of Mechanical Engineers (ASME). Private Correspondence, 01 May 2006.
10. Deutsches Institut für Normung (DIN) EN ISO 10964.
11. Deutsches Institut für Normung (DIN) 54454.
12. Deutsches Institut für Normung (DIN) 65151.
13. Dong, Yubo and Daniel P. Hess. "Accelerated Vibration Life Tests of Threadlocking Adhesive," *Journal of Aircraft* 35(5) (September – October 1998): pp. 816-820.
14. Dong, Yubo and Daniel P. Hess. "The Effect of Threaded Dimensional Conformance on Vibration-Induced Loosening," *Journal of Vibration and Acoustics* 121 (April 1999): pp. 209-213.
15. Dong, Yubo and Daniel P. Hess. "Optimum Placement of Bolts in Structures Based on Dynamic Shear," *Journal of Sound and Vibration* 217(2) (1998): pp. 396-404.

	NASA Engineering and Safety Center Technical Assessment Report	Document #: NESC-RP-04-092	Version: 1.0
Title: Evaluate the Performance of Loctite® as a Secondary Locking Feature for ISS Fasteners			Page #: 55 of 205

16. Dong, Yubo and Daniel P. Hess. "Shock Induced Loosening of Dimensionally Non-Conforming Threaded Fasteners," *Journal of Sound and Vibration* 231(2) (2000): pp. 451-459.
17. Gillis, Jim. "Threads Get a Grip on Shock, Vibration," *Machine Design* 76(1) (January 8 2004): pp. 85-86.
18. Glackin, J. J. and E. F. Gowen, Jr. *Evaluation of Fasteners and Fastener Materials for Space Vehicles*. Standard Pressed Steel Company, Jenkintown, PA, National Aeronautics and Space Administration (NASA) Marshall Space Flight Center (MSFC), December 1965. Contract No. NAS 8-11125, NASA CR 357.
19. Goodier, J. N. and R. J. Sweeney. "Loosening by Vibration of Threaded Fastenings," *Mechanical Engineering* 67 (December 1945): pp. 798-802.
20. Hardiman, Russell J. *Anaerobic Adhesives: A Viable Fastener Locking System*. Society of Manufacturing Engineers, 1974. AD74-429.
21. Hard Lock Industry Co., Ltd. "Testing of Various Types of Hard Lock Nut," *Hard Lock Industry Co., Ltd. Online*. Home page on-line. Available from <http://www.hardlock.co.jp/en/hl/03.php>; Internet; accessed 30 March 2006.
22. Haviland, Girard S. "Designing With Threaded Fasteners," *Mechanical Engineering* 105 (10) (October 1983): pp. 16-31.
23. Haviland, Girard S. "Unraveling the Myths of the Fastener World," Society of Automotive Engineers (SAE) International Automotive Engineering Congress (February 1981) Document 810509.
24. Haviland, Girard S. *Machinery Adhesives for Locking, Retaining, and Sealing*. New York and Basel: Marcel Dekker, Inc., Loctite® Corporation Newington, Connecticut, 1986.
25. Hess, Daniel P. "Counter-Threaded Spring-Actuated Lock-Fasteners," *Journal of Mechanical Design Technical Briefs* 124 (September 2002): pp. 582-585.
26. Hess, Daniel P. and K. Davis. "Threaded Components Under Axial Harmonic Vibration, Part I: Experiments," *Journal of Vibration and Acoustics* 118 (July 1996): pp. 417-422.
27. Hess, Daniel P. and S. V. Sudhirkashyap. "Dynamic Loosening and Tightening of a Sing-Bolt Assembly," *Journal of Vibration and Acoustics* 119 (July 1997): pp. 311-316.
28. Hess, Daniel P., Srinivas Basava, and Ingrid A. Rasquinha. "Variation of Clamping Force in a Single-Bolt Assembly Subjected to Axial Vibration," *DE. 90 Elasto-Impact and Friction in Dynamic Systems ASME* (1996): pp. 97-102.

	NASA Engineering and Safety Center Technical Assessment Report	Document #: NESC-RP- 04-092	Version: 1.0
Title: Evaluate the Performance of Loctite® as a Secondary Locking Feature for ISS Fasteners		Page #: 56 of 205	

29. Hess, Daniel P. "Vibration and Shock Induced Loosening," In John H. Bickford and Sayed Nassar: *Handbook of Bolts and Bolted Joints*, 757-824. New York: Marcel Dekker Inc., 1998.
30. Holland, M. and D. Tran. "FEM Modeling of Threaded Fastener Loosening Due to Dynamic Forces," Proceedings of the Eighth International Conference on Civil and Structural Engineering Computing, Civil-Comp Press, Stirling, Scotland, 2001.
31. Ibrahim, R. A. and C. L. Pettit. "Uncertainties and Dynamic Problems of Bolted Joints and Other Fasteners," *Journal of Sound and Vibration* 279 (2005): pp. 857-936.
32. Jiang, Yanyao, Ming Zhang, and Chu-Hwa Lee. "A Study of Early Stage Self-Loosening of Bolted Joints," *Transactions of the American Society of Mechanical Engineers (ASME)* 125 (September 2003): pp. 518-526.
33. Jiang, Yanyao, Ming Zhang, Tae-Won Park, and Chu-Hwa Lee. "An Experimental Study of Self-Loosening of Bolted Joints," *Journal of Mechanical Design* 126 (September 2004): pp. 925-931.
34. Junker, Gerhard H. "Criteria for Self-Loosening of Fasteners Under Vibration," *Aircraft Engineering* (October 1972): pp. 14-16.
35. Junker, Gerhard H. "Criteria for Self-loosening of Fasteners Under Vibration," *Aircraft Engineering* 42 (2) (February 1973): pp. 20-23.
36. Junker, Gerhard H. "Criteria for Self Loosening of Fasteners Under Vibration," *Aircraft Engineering* (January 1973): pp. 12-17.
37. Junker, G. H. "New Criteria for Self-Loosening of Fasteners Under Vibration," Society of Automotive Engineers (SAE) International Automotive Engineering Congress (January 1969): pp. 314-335.
38. Kerley, James J., "An Application of Retrodution to Analyzing and Testing the Backing Off of Nuts and Bolts During Dynamic Loading," National Aeronautics and Space Administration (NASA) Scientific and Technical Information Office, Goddard Space Flight Center (GSFC) 1987. NASA TM 4001.
39. Kerley, James J. "The Use and Misuse of Six Billion Bolts Per Year" Society for Machinery Failure Prevention Technology, Thirty-fifth Meeting, Session IV: System Assessment and Response.
40. Kerley, James. "Nuts and Bolts: Practical Applications for Bolts and Nuts for the Designer" National Aeronautics and Space Administration (NASA) Goddard Space Flight Center (GSFC) TM 109783 January 1980.
41. Kerley, James. "Report on Dynamic and Static Testing of Spirallock Nuts," National Aeronautics and Space Administration (NASA) Goddard Space Flight Center (GSFC)

	NASA Engineering and Safety Center Technical Assessment Report	Document #: NESC-RP-04-092	Version: 1.0
Title: Evaluate the Performance of Loctite® as a Secondary Locking Feature for ISS Fasteners		Page #: 57 of 205	

Engineering Services Division, Environmental Test and Integration Branch, Structural Dynamics and Electromagnetic Test Section, September 1984.

42. Kumakura, Susumu, Syuzi Hosokawa, and Toshiyuki Sawa. "On the Self-loosening of a Bolts Nuts Under Repeated Tensile Loads," *American Society of Engineering (ASME) Pressure Vessels and Piping (PVP)* 305, Current Topics in Computational Mechanics, (1995): pp. 119-124.
43. Light, D. J. "Vibration Loosening of Threaded Fastenings," *Institution of Mechanical Engineers Chartered Mechanical Engineer (CME)* 30 (5) (May 1983): pp. 56-60.
44. Loctite. "Junker Test Principle," *Loctite Online*. Home page on-line. Available from <http://www.loctite.be/wwdh/us/i061ch03.htm>; Internet; accessed 30 March 2006.
45. Nakahara, Takeshi, Masaaki Yamamoto, Yusuke Ohya, and Masaaki Okuma. "Bolt Loosening Detection Using Vibration Characteristics of Thin Plate with Piezoelectric Elements," *Smart Structures and Materials SPIE* 5391 (2004): pp. 667-678.
46. Nassar, S. A. and B. A. Housari. "Self-loosening of Threaded Fasteners Due to Cyclic Transverse Loads," *American Society of Mechanical Engineers (ASME) Pressure Vessels and Piping Division Conference* Denver, Colorado, USA, PVP2005-71577 (July 17-21, 2005): pp. 169-187.
47. Nord-Lock. "Junker Test Principle," *Nord-Lock Online*. Home page on-line. Available from <http://www.nord-lock.com/default.asp?url=6.16.37>; Internet; accessed 30 March 2006.
48. Pai, N. G. and Daniel P. Hess. "Dynamic Loosening of Threaded Fasteners," *Noise and Vibration Worldwide* (February 2004): pp. 13-19.
49. Pai, N. G. and Daniel P. Hess. "Experimental Study of Loosening of Threaded Fasteners Due to Dynamic Shear Loads," *Journal of Sound and Vibration* 253 (3) (2002): pp. 585-602.
50. Pai, N. G. and Daniel P. Hess. "Influence of Fastener Placement on Vibration-Induced Loosening," *Journal of Sound and Vibration* 268 (2003): pp. 617-626.
51. Pai, N. G. and Daniel P. Hess. "Three-dimensional Finite Element Analysis of Threaded Fastener Loosening Due to Dynamic Shear Load," *Engineering Failure Analysis* 9 (2002): 383-402.
52. Pearce Jr., M. B. "A Study of Vibration-Resistant Fasteners," *Society of Automotive Engineers (SAE) Document No. 730825* (1973): pp. 1-5.

	NASA Engineering and Safety Center Technical Assessment Report	Document #: NESC-RP-04-092	Version: 1.0
Title: Evaluate the Performance of Loctite® as a Secondary Locking Feature for ISS Fasteners			Page #: 58 of 205

53. Ramey, Ed G. and Robert C. Jenkins. *Experimental Analysis of Thread Movement in Bolted Connections Due to Vibrations*, Alabama: Harbert Engineering Center, Civil Engineering Department, Auburn University, NAS8-39131.
54. Sakai, Tomotsugu. "Investigations of Bolted Loosening Mechanisms, 1st Report: On the Bolts of Transversely Loaded Joints," *Bulletin of the Japan Society of Mechanical Engineers (JSME)* 21(159) (1978): pp. 1385-1390.
55. Vinogradov, O. and X. Huang. "On a High Frequency Mechanism of Self-Loosening of Fasteners," *American Society of Mechanical Engineers (ASME) Design Engineering Division Publication DE*, 18 (4) Vibration Analysis – Techniques and Applications Conference (1989): pp. 131-137.
56. Wineman, Steve. American National Standards Institute (ANSI), Director of Standardization and Testing. Private Correspondence, 25 April 2006.
57. Yamamoto, Akira and Shinji Kasei. "A Solution for Self-Loosening Mechanism of Threaded Fasteners Under Transverse Vibration," *Bulletin Japan Society of Prec. Engineering* 18 (3) (September 1984): pp. 261-266.
58. Yost, V. H. "Random Vibration and Torque Tests of Fasteners Secured With Cable, Room Temperature Vulcanized (RTV) Rubber, and Closed Cell Foam to Support the Launch of STS-82," National Aeronautics and Space Administration (NASA) Marshall Space Flight Center (MSFC), August 1997. NASA TM 108539.
59. Zhang, Ming, Yanyao Jiang, and Chu-Hwa Lee. "An Experimental Investigation of the Effects of Clamped Length and Loading Direction on Self-Loosening of Bolted Joints," *American Society of Mechanical Engineers (ASME) Pressure Vessels and Piping (PVP)* 478, Analysis of Bolted Joints, July 25-29, San Diego, California, USA, PVP2004-2631. (2004): pp. 129-136.
60. Zhang, Ouqi. "Discussions on Behavior of Bolted Joints in Tension," *Transactions of the American Society of Mechanical Engineers (ASME)* 127 (May 2005): pp. 506-510.
61. Zhang, Ouqi and Jason A. Poirier. "New Analytical Model of Bolted Joints," *Journal of Mechanical Design* 126 (July 2004): pp. 721-728.

Volume II: Appendices

- Appendix A. Space Flight Environments for ISS
- Appendix B. Question and Answer meeting with Loctite® Representative
- Appendix C. Evaluation of Anaerobic Locking Compounds, Tensile Testing, Torque Tension Testing, and Breakloose and Running Torque Testing
- Appendix D. CTE Effects of Fastener Mechanical Loads
- Appendix E. NASM1312-7 Vibration Testing Test Plan

	NASA Engineering and Safety Center Technical Assessment Report	Document #: NESC-RP- 04-092	Version: 1.0
Title: Evaluate the Performance of Loctite® as a Secondary Locking Feature for ISS Fasteners		Page #: 59 of 205	

- Appendix F. Comparison of Secondary Locking Features for Threaded Inserts, July 2007
- Appendix G. Thermal/Vacuum Cyclic Testing Plan and Results
- Appendix H. Human Factors Review of Application Process for Liquid Locking Compounds (LLC) in ISS Hardware
- Appendix I. Loctite® Application Process Comparison
- Appendix J. Literature Review of the Self-Locking of Threaded Fasteners



**NASA Engineering and Safety Center
Technical Assessment Report**

Document #:
**NESC-RP-
04-092**

Version:
1.0

Title:

**Evaluate the Performance of Loctite® as a Secondary
Locking Feature for ISS Fasteners**

Page #:
60 of 205

VOLUME II: Appendices

Appendix A. Space Flight Environments for ISS

Space Flight Environments for ISS

EVA Environments

Environment Factor	Source	Worst Case Value	Comments	Evaluation Rationale
Natural Ambient Atmosphere	SSP- 30425	2.8×10^{-10} torr	Neutral atmosphere only	Non Factor - Vacuum only not degrading
Induced Ambient Atmosphere	Vehicle configuration and flight attitude dependent: requires detailed rarefied gas dynamic calculations with NASAN II (Boeing ISS Environments)	Ranges from $> 10^{-4}$ torr to $< 10^{-10}$ torr:	<ol style="list-style-type: none"> 1) Vehicle interaction with ambient atmos. 2) Vehicle outgassing 3) Plumes, vents and dumps 	Vacuum only under evaluation for cure Temperature under evaluation – Product information states use from -65°F to 300°F
Solar UV/VUV	SSP-30425 7.2	9.5×10^{-3} W/m ²	Photon Wavelength = 150 nm to 10 nm	Non Factor – Loctite® protected by metallic fastener
Nominal Solar X-rays	SSP-30425	5×10^{-5} W/m ²	Photon Wavelength = 1 nm to 10 nm	Non Factor – Loctite® protected by metallic fastener
Flare Solar X-rays	SSP-30425	1×10^{-4} W/m ²	Photon Wavelength = 0.1 nm to 1 nm	Non Factor – Loctite® protected by metallic fastener
Atomic Oxygen	SSP-41000 and SSP-30425 (MSIS)	1.5×10^{19} atoms/cm ² per day (24 hrs)	Forward facing vehicle surfaces only – near 0 in wake	Non Factor – Loctite® protected by metallic fastener
Ionizing Radiation 2.1×10^{-4} g/cm ² (surface)	SSP-30512 Rev. C 3.1.2-2	1.1×10^4 Rads(Si) per day (24 hrs)	Mostly trapped electrons Slab configuration	Non Factor – Loctite® protected by metallic fastener
Ionizing Radiation 0.11 g/cm ² (approx. 0.5 mm Al)	SSP-30512 Rev. C 3.1.2-2	7.3 Rads (Si) per day (24 hrs)	Mostly trapped electrons Slab configuration	Non Factor – Loctite® protected by metallic fastener



NASA Engineering and Safety Center Technical Assessment Report

Document #:
**NESC-RP-
04-092**

Version:
1.0

Title:

Evaluate the Performance of Loctite® as a Secondary Locking Feature for ISS Fasteners

Page #:
61 of 205

Environment Factor	Source	Worst Case Value	Comments	Evaluation Rationale
Ionizing Radiation 0.5 g/cm ² (approx. 1.8 mm Al)	SSP-30512 Rev. C 3.1.2-2	0.6 Rads (Si) per day (24 hrs)	Mostly trapped electrons Slab configuration	Non Factor – Loctite® protected by metallic fastener
Ionizing Radiation 3.5 g/cm ² (approx. 12 mm Al)	SSP-30512 Rev. C 3.1.2-2	0.04 Rads (Si) per day (24 hrs)	Mostly trapped protons Slab configuration	Non Factor – Loctite® protected by metallic fastener
External Contamination	SSP-30426 3.5.1	2.7 x 10 ⁻⁹ g/cm ² per day	Depends on location and line of site to sources	Non Factor – cured Loctite® stable, small amounts used
On-Orbit Humidity	SSP-30425 (MSIS) and SSP-30233	0 percent	worst case = nominal	Non Factor – Product information states Loctite® can be used underwater after cure

	NASA Engineering and Safety Center Technical Assessment Report	Document #:	Version:
		NESC-RP-04-092	1.0
Title:			Page #:
Evaluate the Performance of Loctite® as a Secondary Locking Feature for ISS Fasteners			62 of 205

Appendix B. Question and Answer meeting with Loctite® Representative

Q&A from Brian Jensen to Loctite®.
Dialogues from September and November 2006 Combined (1/18/07).

1. Two of the Mil standards that are important to us are MIL-S-46163 and MIL-S-22473 (now cancelled, but superseded by ASTM D5363). With regard to Loctite® 242, Loctite® 2440 and Loctite® 271, are these products qualified to the above standards or is there any correlation between the Loctite® products and Mil standards in general?

A1. I have attached a mil spec listing. 2440 is not tested to any mil spec. 242 & 271 both are tested to MIL-S-46163A for existing designs.

(See attached file: MILITARY LISTING '06.doc) attached to original document

2. Please clarify the role of the Primer N, Primer T, etc. Does it act as a primer for improved surface bonding, as an activator for the Loctite® cure, or both? Discuss the requirements/benefits/limitations of using the primers with regard to the composition of the fastener, in particular steel, stainless steel, titanium, aluminum, or plastic. Loctite® literature indicates that when the primer/activator is used, the strength of the final bond on steel substrate (indicated by "percent full strength on steel") is lower than that without primer/activator although the time for cure is reduced. Please clarify this data.

A2. One of the main functions of the primer is to ensure full cure in 24 hours at room temperature. The primer puts a layer of metal ions down on the part to accelerate the cure on "inactive metals" which are defined as any protective coatings such as stainless steel, titanium, platings, anodized aluminum and galvanized steel. The threadlockers cure in the absence of air and metal ions are a catalyst in curing them. 7649 contains copper salt & 7471 contains an amine and these serve that function. The strength may be lower on active metals when a primer is used because it accelerates the crosslinking of the polymer versus using no primer. However, its function on inactive metals like stainless steel is different in the sense that ensures full cure in 24 hours. If no primer is used on inactive metals like stainless, most of the threadlockers will take significantly longer to fully cure and the timeframe is highly unpredictable. It could take 2-3 weeks to fully cure without a primer.

The real question becomes how extreme are the service conditions and when do you want to put the parts back in service?

	NASA Engineering and Safety Center Technical Assessment Report	Document #: NESC-RP-04-092	Version: 1.0
Title: Evaluate the Performance of Loctite® as a Secondary Locking Feature for ISS Fasteners			Page #: 63 of 205

3. What are your thoughts/position on the reuse of fasteners/and or inserts with previously cured Loctite® in the threads? How would you recommend cleaning the threads? NASA has used "non-cutting taps" to clean previously cured Loctite®. Is this method recommended? With regard to re-use of fasteners previously containing Loctite®, after cleaning, how well does new Loctite® bond to old remnants of Loctite® and should the same Loctite® product be re-used or can another be substituted?

A3. The cleaner the threads, the better, prior to reuse. If you have some residue left, the new product should adhere to the old, whether it's the same product or a different threadlocker. Aggressive solvents like methylene chloride or methyl ethyl ketone are used and often the threads are wire brushed as well. The substitution of new hardware of course is another option. You'll have to test to determine suitability for reuse if you cannot adequately remove all old residue and compare the results versus a control or the first application results.

4. Can you provide a performance comparison between Loctite® 242 and Loctite® 2440?

A4. 242 versus 2440. I would review the attached TDS's. Both are medium strength products and 2440 is a newer generation product that cures faster and provides primerless adhesion to most "inactive metals", unlike 242.

(See attached file: 242-EN.pdf)(See attached file: 2440-EN.pdf) these were attached to original

5. Do you have any information on Loctite® performance (curing, break-loose torque) as a function of the installation preload? Does Loctite® cure and provide adequate back-off prevention when installed in a fastener with just sufficient seating torque (hand tight)? Does applied preload effect bonding/cure sensitivity of Loctite® differently as a function of fastener and mating thread material or class of thread (class 2 versus class 3)?

A5. The TDS's may answer this in part. Breakaway values reflect the strength of the product alone, on unseated fasteners. Breakloose reflects a seated fastener. Is the product sufficient for finger tightened assemblies? Every application is different and I would imagine it is in some cases, but not others. This question needs to take into consideration how extreme the service conditions are. I don't believe the applied preload will affect the bonding/curing sensitivity of the threadlocker although the strength of the product will vary from type metal to the next. Here you'll have to do some internal testing for different scenarios.

6. Is Loctite®'s strength sensitive to vacuum and/or or thermal cycling between the limits described in the product specifications as a function of time of exposure?

	NASA Engineering and Safety Center Technical Assessment Report	Document #: NESC-RP-04-092	Version: 1.0
Title: Evaluate the Performance of Loctite® as a Secondary Locking Feature for ISS Fasteners		Page #: 64 of 205	

A6. This question in relation to thermal cycling is best answered by reviewing the Heat Aging graphs on individual TDS's. If under constant vacuum, the products will continue to outgas after cure. None of the products tested by NASA in the past met the requirements for both TWL percent & CVCM percent limits. Then again, the products are used in minute amounts in a tight space and this does not reflect the NASA cold plate test. Testing under actual service conditions would be recommended.

7. Do you have any test data/information on use of Loctite® on fasteners with Dry Film Lubricants (DFL)? Will Loctite® adhere/bond to DFL? If so, at what strength level compared to ferrous metals? If not, do you have recommendations on effective cleaning methods of DFL? Also, please discuss the effect of oils and rust inhibitors on the performance of Loctite®.

A7. There is no test data on the use of threadlockers with dry film lubricants. I would imagine they'll adhere to the DFL, but this will need to be tested to determine strength if both are used simultaneously. I would contact the manufacturer of the DFL and ask they what they suggest for removal. All products are not the same. Oil-free surfaces are recommended for most threadlockers. If a rust inhibitor contains nitrites, this can inhibit the cure of threadlockers. This should be removed prior to use if so.

8. Do you have any test data/information on Loctite® bonding to aluminum threads?

A8. There is no test data on aluminum threads.

9. Is there a filler in the Loctite® 271 that causes the significant increase in running torque after the initial break-loose torque is realized? Is this increase in running torque a consistent and repeatable performance parameter for the material? If this effect is not the result of a filler, is it a result of a higher modulus or hardness of the Loctite® 271 compared to the Loctite® 242?

A9. Higher prevailing torque values are more a function of the toughness of the monomer base & also a function of the fact that the product forms a tighter matrix when it crosslinks versus some of the other threadlockers. This should be consistent and repeatable, especially with substrates where you obtain high strength in the first place. All threadlockers are high modulus, low flex formulations, but some products just exhibit higher prevailing after the initial break due to monomer functionality.

10. What is the cure time for Loctite® 242, Loctite® 271, and Loctite® 2440 and can this be accelerated by temperature and/or vacuum? Can you provide time based strength curves or other data for these products on different substrates with and without Primer?

	NASA Engineering and Safety Center Technical Assessment Report	Document #: NESC-RP-04-092	Version: 1.0
Title: Evaluate the Performance of Loctite® as a Secondary Locking Feature for ISS Fasteners			Page #: 65 of 205

A10. The full cure for all three (3) products is 24 hours at room temperature. The fixture time will vary from one substrate to the next and one thread size to the next. Refer to the TDS's for reference data. You can accelerate the cure via heat if this sees 250°F for 1 hour or temperatures as low as 150°F for 3 hours. Vacuum conditions won't accelerate the cure.

11. What are the effects of humidity on the cure process for these products?

A11. Generally, humidity won't affect cure parameters. These are not moisture activated products. Any data we have would be presented on the TDS.

12. Do you have any data on Loctite® offgassing in an ambient (Earth) or vacuum (Space) environment for properly cured product?

A12. Outgassing under vacuum...no data for 2440 (never tested by NASA). 242 - 4.39 percent TWL & 0.00 percent CVCM. 271 - 13.36 percent TWL & 1.94 percent CVCM. Only testing was done under vacuum.

13. Loctite® appears to be sensitive to application process. What process verification test does Loctite® recommend for a given flight fastener?

A13. I don't have information on flight fastener conditions. I don't know if Barry Sadler, our Boeing rep, could better answer this. He is in WA at 800 323-5106, hit choice # 1 and enter mailbox # 6118 when prompted.

14. Can you provide any information concerning storage life in addition to that listed on the products? What is the shelf life of an open container? Does the size of the original container or residual amount of unused Loctite® effect shelf life? Are “single use packages” available and, if so, what are the advantages of this packaging compared to standard size packaging?

A14. We do not specify shelf life after product is opened. These are very stable products and they're generally stored at room temperature in a cool, dry location. I have seen product opened years previous and there was no noticeable difference in appearance, cure rate, strength, etc. The key is to avoid contamination issues (i.e. touching the bottle tip directly down on a metal surface & sucking metal ions into the bottle that can lead to premature cure/hardening in the bottle).

15. Loctite® 271 (Grade AV, red color) requires heat for disassembly. How much heat is required?

A15. Disassembly is 450°F temperatures and remove at temperature for both 271 & AV (these are two different products).

	NASA Engineering and Safety Center Technical Assessment Report	Document #: NESC-RP-04-092	Version: 1.0
Title: Evaluate the Performance of Loctite® as a Secondary Locking Feature for ISS Fasteners		Page #: 66 of 205	

16. Do you recommend different fastener sizes for Loctite® 271, Loctite® 242, and Loctite® 2440? If so, what is the size range recommended for each product?

A16. The attached table answers your question about typical bolt treating range.

17. What is the use temperature range for Loctite® 242, Loctite® 2440, and Loctite® 271? Describe the data used to determine the use temperature ranges for these products.

A17. We generally state a range of -65°F - 300°F. However, the most accurate answer to this question is to view the Hot Strength & Heat Aging graphs presented on the TDS's. These more closely mimic sustained high temperature & thermal cycling conditions. Anaerobics in general cover this broad temperature range, but every application is different and the performance at said temperature will vary from one product to the next and one application to the next, taking into consideration all application parameters.

ANSWERS TO THESE QUESTIONS WERE PROVIDED (on Sept 8, 2006)) BY:
Michael Smigel
North American Engineering Center Henkel/Loctite® Adhesives Rocky Hill, CT USA

	NASA Engineering and Safety Center Technical Assessment Report	Document #: NESC-RP-04-092	Version: 1.0
Title: Evaluate the Performance of Loctite® as a Secondary Locking Feature for ISS Fasteners			Page #: 67 of 205

1) Q: In Military specification MIL-S 45163A, the primer activator "Grade F" is called out. Although I haven't found grade F primer on the Loctite® website, I have found grade NF (called primer # 736).

Is there a primer activator grade F? What are the differences/advantages of grade F and/or grade NF(#736) compared with #7471 (grade T) and #7649 (grade N)?

A-1: the old, discontinued version of Loquic Primer N, product 764, met the requirements of MIL-S-46163 A Grade F. However, we never tested and certified this to the specification. This contained 1,1,1 trichloroethane and we took this off the market in 6/95. This was replaced by Locquic Primer N, product 7649. This latter alternative simply has a different carrier solvent, acetone. Otherwise, the function is the same. 7649 is also not tested and certified to the spec although it generally meets the requirements. 7649 is tested to MIL-S-22473E Grade N Form R for existing designs and primers meeting this mil spec can be used with the adhesive/sealants that meet MIL-S-46163A. Locquic Primer NF, product 736, is not tested & certified to any mil specs. This is essentially a faster version of Loquic Primer N, 7649 and will provide faster fixturing with some of the machinery adhesives. Often Locquic Primer N & T are used interchangeably, with the only major difference being there on part life after drying on a part, prior to assembly. N is one month and T is one week. NF has a 30 minute maximum on part life.

2) Q: In the Loctite® specs for 242, instructions indicate application of Loctite® to bolt only for thru holes, but recommends application of Loctite® to both male and female threads for blind holes. Why the difference?

A-2: We recommend applying threadlocker to both male & female threads for blind holes to ensure uniform coverage of the threadlocker around the diameter and to ensure proper cure. If the threadlocker is just applied to the male threads and you torque this down, air pressure will force too much of the product out as you torque it down. The result is insufficient coverage around the threads and the product will start to cure/cross link, but it never fully cures. As a result, you experience premature failures. If applied to both parts for blind holes, this will compensate enough for squeeze out as you torque the assembly down. Often, if the product is applied incorrectly for blind holes, the failed assembly will have the appearance of a white, plastic ground up film with residual purple, blue or red color (depending on the product used) mixed in with it. This shows that it started to cure, but never fully cured. If properly applied, assemblies should have the appearance of a white, plastic ground up film exclusively, on the threads, once disassembled. There would be no residual of the original color mixed in. For thru holes assemblies, such as a nut and bolt combination, you simply apply the threadlocker to the male threads only and assemble.

	NASA Engineering and Safety Center Technical Assessment Report	Document #: NESC-RP- 04-092	Version: 1.0
Title: Evaluate the Performance of Loctite® as a Secondary Locking Feature for ISS Fasteners		Page #: 68 of 205	

ANSWERS TO THESE QUESTIONS WERE PROVIDED (on Nov 16, 2006) BY:

Michael Smigel
North American Engineering Center
Henkel/Loctite® Adhesives
Rocky Hill CT USA

Q1. After removing fasteners that were coated with Loctite®, we have noticed a difference in the residual Loctite®/thread appearance for different products and wonder if this is an indication of different threadlocking mechanisms at work. Can Loctite® confirm that threadlockers (Product 242 and 271) with primer/activator on stainless steel fasteners provide locking primarily or effectively by filling voids between the threads and damp vibration or do these products provide locking by bonding with the stainless steel threads (an adhesive effect)? Are there data to support the effects or relative contributions of the different locking mechanisms?

A1. Brian, in essence the threadlockers perform both functions filling the voids and also providing adhesion to the metal. I'm not sure I understand what you're asking in your last question. What supporting data we have is typically representing on said TDS's.

ANSWERS TO THIS QUESTION WAS PROVIDED (on Jan 26, 2007) BY:

Michael Smigel
North American Engineering Center
Henkel/Loctite® Adhesives
Rocky Hill CT USA

	NASA Engineering and Safety Center Technical Assessment Report	Document #:	Version:
		NESC-RP-04-092	1.0
Title: Evaluate the Performance of Loctite® as a Secondary Locking Feature for ISS Fasteners		Page #: 69 of 205	

Appendix C. Evaluation of Anaerobic Locking Compounds, Tensile Testing, Torque Tension Testing, and Breakloose and Running Torque Testing

Updated January 18, 2006

C.0 INTRODUCTION

The purpose of this test is to develop data on the effects of process variability that are likely to be encountered in using anaerobic threadlockers on ISS hardware. The data are intended to contribute to the understanding of the root cause of past failures and to be a guide for evaluating standards and processes for the use and application of Anaerobic threadlockers on ISS hardware. This testing will address mainly cure issues and fastener design parameters.

C.1 Test Justification

A number of ISS hardware components use anaerobic locking compounds as a means of meeting the redundant locking feature requirement for fasteners. Recently, the reliability of Anaerobic locking compounds has been brought into question due to a number of failures during ground testing. Failures have been related to a lack of proper procedures being followed for Anaerobic locking compound application, leading to incomplete curing.

C.2 TEST OBJECTIVES

- A. Obtain typical load extension curves for fasteners and determine Johnson's 2/3rd's yield load values for the fasteners.

- B. Determine torque-tension relationships for various fastener/substrate combinations using anaerobic locking compounds and determine friction (k) factors.

- C. Evaluate level of adhesion and cure of anaerobic locking compounds results by conducting break loose and running torque tests on fastener/substrate/locking compound combinations and by conducting microscopic inspections of disassembled test specimens.

C.3 APPLICABLE DOCUMENTS

Document	Title
MSFC-STD-486	Standard, Threaded Fasteners, Torque Limits For
EM10-OWI-MET-021	Torque Tension Testing of Metallic Fastening Systems
NAS1352N08-16	Screw, Cap, Socket Head, Undrilled and Drilled, Plain and Self Locking, Alloy Steel and Corrosion resisting Steel, UNRC-3A
NASM122119	Insert, CRES Helical Coil Coarse Thread, 1-1/2 Dia Nominal Length
AN960-08	Washer, Flat
NAS1004-8A	Bolt - Machine, Hexagon Head, Non Magnetic, & Heat Resistant

	NASA Engineering and Safety Center Technical Assessment Report	Document #:	Version:
		NESC-RP-04-092	1.0
Title: Evaluate the Performance of Loctite® as a Secondary Locking Feature for ISS Fasteners			Page #: 70 of 205

Document	Title
NASM124696	Insert, CRES Helical Coil Fine Thread, 1-1/2 Dia Nominal Length
NAS1587-4C	Washer, Plain and Countersunk, 1200°F
MS51831CA202L	Insert, Screw-Thread, Locked In, Key-Locked, Heavy Duty
NAS1958	Bolt, Shear, Hexagon Head 108ksi Shear, Long Thread
NASM124700	Insert, CRES Helical Coil Fine Thread, 1-1/2 Dia Nominal Length
NAS1587-8C	Washer, Plain and Countersunk, 1200°F
Loctite® 242	Anaerobic locking compound
Loctite® 271	Anaerobic locking compound
NASM1312-8	Fastener Test Methods, Method 8, Tensile Test
NAS1069	Tension Fatigue Test Procedure For Aeronautical Fasteners

C.4 TEST DESCRIPTION

Load-extension curves will be developed for NAS1352N08-16, NAS1004-8A, and NAS1958-32 fasteners. Johnson's 2/3rd's yield load values will be determined for each fastener type using NASM1312-8 test procedures. Johnson's 2/3rd's yield load values will be used to determine load levels for torque-tension testing.

Torque-tension curves will be developed for various fastener/substrate/locking compound combinations to establish torque values to use for locking compound level of adhesion and cure of anaerobic locking compound evaluations. Loctite® 242 will be used for 0.164" diameter and 0.250" diameter fasteners. Loctite® 271 will be used for 0.500" diameter fasteners.

Break loose and running torque tests will be conducted to evaluate level of adhesion and cure of anaerobic locking compounds. Microscopic inspections and photography will be performed to support these evaluations.

C.4.1 Test Article Description

C.4.1.1 Fastener tensile testing will be performed using a standard mechanical testing load frame and a NAS 1069 clevis (see enclosed picture). Three fasteners of each size - 0.164-32, 0.2500-28, and 0.5000-20, shall be tested.



NASA Engineering and Safety Center Technical Assessment Report

Document #:
**NESC-RP-
04-092**

Version:
1.0

Title:

Evaluate the Performance of Loctite® as a Secondary Locking Feature for ISS Fasteners

Page #:
71 of 205



C.4.1.2 Torque-tension testing will be performed in accordance with MSFC-STD-486 and EM10-OWI-MET-021 procedures using an SPS torque-tension testing machine capable of recording the induced load on the sample while simultaneously measuring the applied torque. Torque transducers of an appropriate torque range will be used to torque fasteners. Load cells of an appropriate load range will be used to record load during testing. Fasteners will be torqued from the head. Fasteners will be torqued into specimens containing either non-locking helical inserts, locking inserts, or tapped holes. An overview photograph of the torque-tension machine is shown below along with photographs showing typical tooling/fixtures for torquing the fasteners.

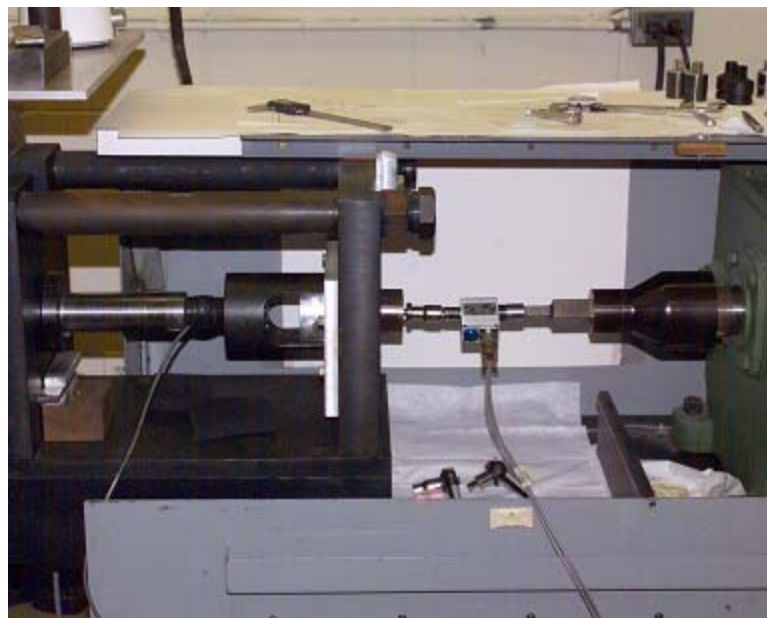



**NASA Engineering and Safety Center
Technical Assessment Report**

Document #:
**NESC-RP-
04-092**

Version:
1.0

Title:

**Evaluate the Performance of Loctite® as a Secondary
Locking Feature for ISS Fasteners**

Page #:
72 of 205

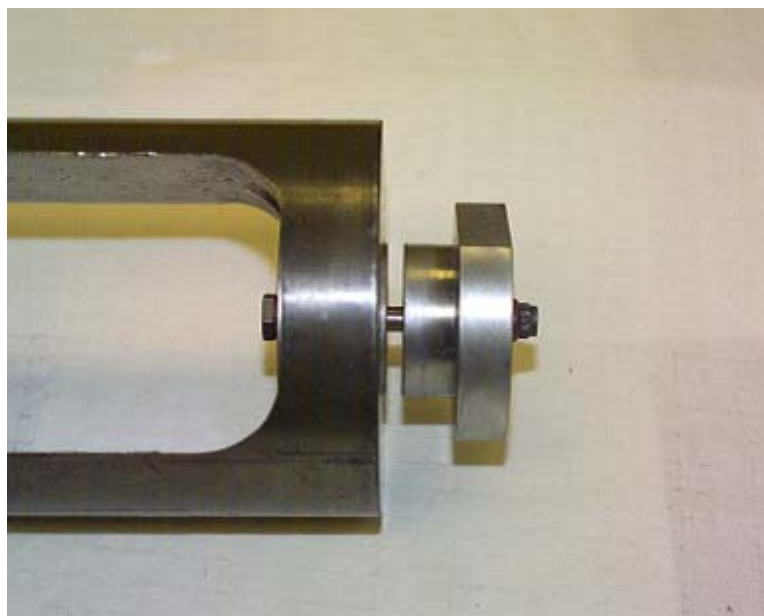



NASA Engineering and Safety Center Technical Assessment Report

Document #:
**NESC-RP-
04-092**

Version:
1.0

Title:

Evaluate the Performance of Loctite® as a Secondary Locking Feature for ISS Fasteners

Page #:
73 of 205

A typical torque-tension testing test block is shown below.

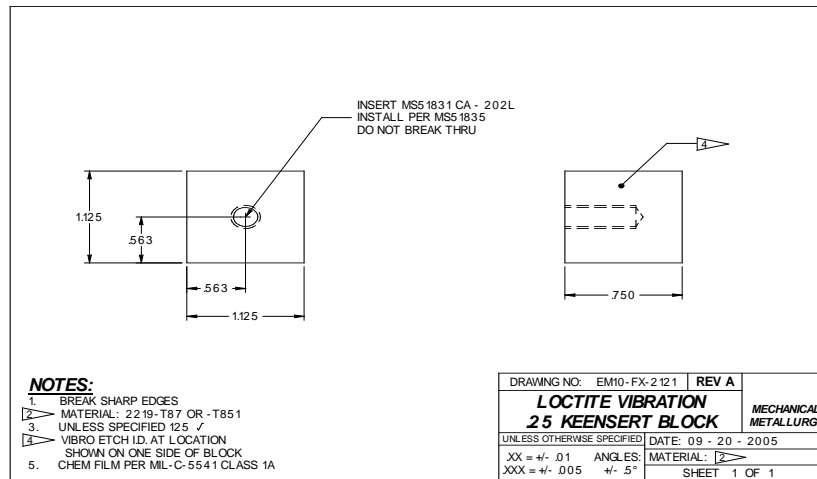

C.4.1.3 Break loose and running torque testing will be performed by torquing fasteners through spacers into test plates. A typical test plate and a typical test plate spacer are shown below. Fasteners shall be torqued as follows: row 1 to 100% torque (inch-pound) levels, row 2 to 75% torque levels, row 3 to 50% torque levels, and row 4 to 20% torque levels. Eight fasteners in each row shall be torqued with anaerobic locking compounds applied to the fastener threads. One of the eight fasteners in each row shall be installed through a load washer plus a spacer into test plates. Three fasteners in each row shall be used as control samples and torqued without locking compounds.

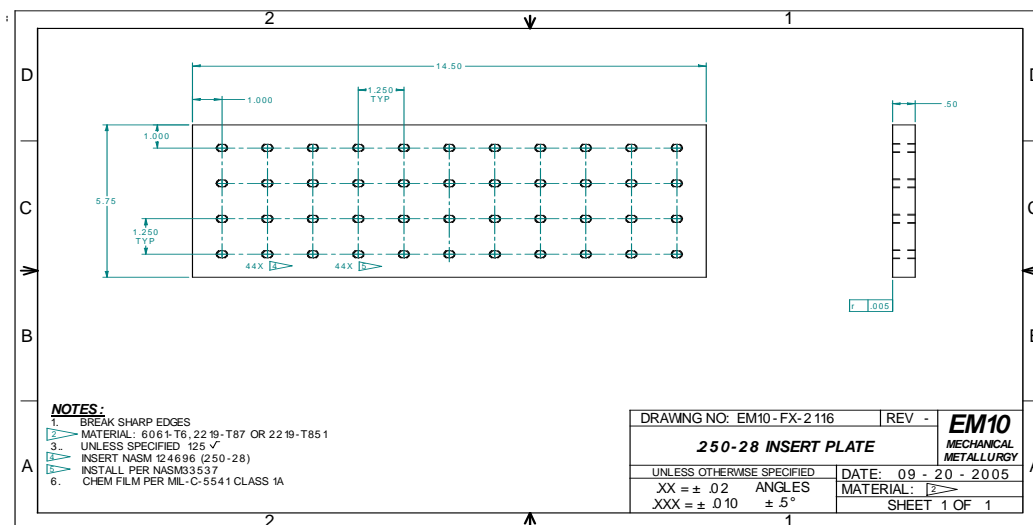



NASA Engineering and Safety Center Technical Assessment Report

Document #:
**NESC-RP-
04-092**

Version:
1.0

Title:

Evaluate the Performance of Loctite® as a Secondary Locking Feature for ISS Fasteners

Page #:
74 of 205

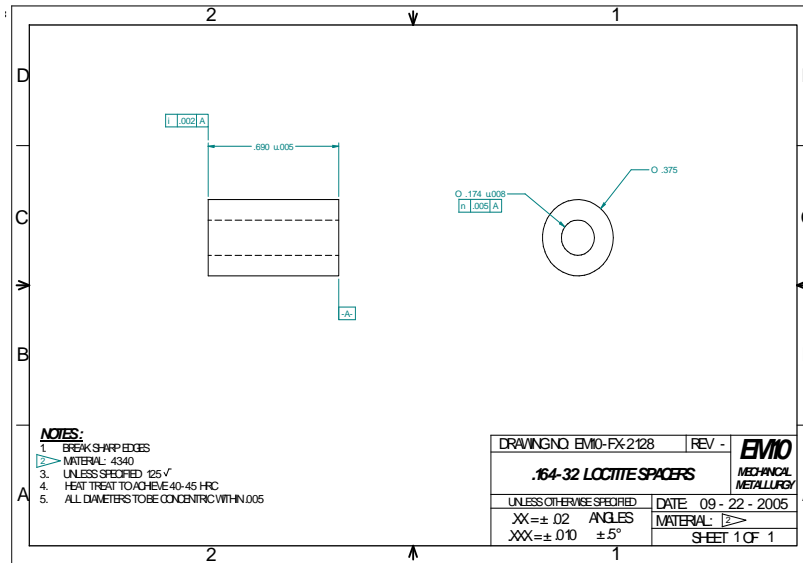

C.4.2 Bolt Marking

Fasteners of nominal diameter 0.1640-32 will be identified by bagging and tagging in plastic bags and numbering the bags from 1 - 44. Fasteners of nominal diameter 0.2500-28 will be identified by bagging and tagging in plastic bags and numbering the bags from 1 - 440. Fasteners of nominal diameter 0.5000-20 will be identified by bagging and tagging in plastic bags and numbering the bags from 1-88.

C.4.3 Torque-Tension Testing Test Block Marking

Torque-tension test blocks shall be labeled as indicated in table 1.

Appendix 2: Test Configuration	Size	Substrate	Insert/Hole	Lubricant	Test Block ID
1	.2500-28	2219-T87 or T851	NASM124696, 1.5D	Loctite® 242	25-1 to 25-5
1	.2500-28	2219-T87 or T851	NASM124696, 1.5D	Braycote® 601	25-6 to 25-10
5	.1640-32	2219-T87 or T851	NASM122119, 1.5D	Loctite® 242	16-1 to 16-5
5	.1640-32	2219-T87 or T851	NASM122119, 1.5D	Braycote® 601	16-6 to 16-10
9	.5000-20	2219-T87 or T851	NASM124700, 1.5D	Loctite® 271	50-1 to 50-5
9	.5000-20	2219-T87 or T851	NASM124700, 1.5D	Braycote® 601	50-6 to 50-10
17	.2500-28	A286	H2 class 3 tapped hole, 1.5D	Loctite® 242	25H2-1 to 25H2-5
17	.2500-28	A286	H2 class 3 tapped hole, 1.5D	Braycote® 601	25H2-6 to 25H2-10
21	.2500-28	A286	H4 class 3 tapped hole, 1.5D	Loctite® 242	25H4-1 to 25H4-5
21	.2500-28	A286	H4 class 3 tapped hole, 1.5D	Braycote® 601	25H4-6 to 25H4-10
33	.5000-20	A286	H4 class 3 tapped hole, 1.5D	Loctite® 271	50H4-1 to 50H4-5



NASA Engineering and Safety Center Technical Assessment Report

Document #:
**NESC-RP-
04-092**

Version:
1.0

Title:

Evaluate the Performance of Loctite® as a Secondary Locking Feature for ISS Fasteners

Page #:
75 of 205

Table 1: Torque-Tension Test Block Identification Labels

Appendix 2: Test Configuration	Size	Substrate	Insert/Hole	Lubricant	Test Block ID
33	.5000-20	A286	H4 class 3 tapped hole, 1.5D	Braycote® 601	50H4-6 to 50H4-10
37	.2500-28	2219-T87 or T851	MS51831CA202L	Loctite® 242	25K-1 to 25K-5
37	.2500-28	2219-T87 or T851	MS51831CA202L	Braycote® 601	25K-6 to 25K-10

C.4 Break loose and Running Torque Test Plate Marking

Break loose and running torque test plates shall be marked as shown in table 2.

Table 2: Break Loose/Running Torque Test Plate Identification Labels

Size	Substrate	Insert/Hole	Test Plate ID's
.1640-32	2219-T87 or T851	NASM122119, 1.5D, thru	16TP-1
.2500-28	2219-T87 or T851	NASM124696, 1.5D, thru	25TP-1
.2500-28	2219-T87 or T851	NASM124696, 1.5D, blind	25TP-2
.2500-28	A286	H2 class 3 tapped hole, 1.5D, thru	25TP-3
.2500-28	A286	H4 class 3 tapped hole, 1.5D, thru	25TP-4
.2500-28	A286	H4 class 3 tapped hole, 1.5D, blind	25TP-5
.2500-28	2219-T87 or T851	MS51831CA202L, thru	25TP-6
.2500-28	2219-T87 or T851	NASM124696, 1.5D, thru	25TP-7
.2500-28	2219-T87 or T851	NASM124696, 1.5D, thru	25TP-8
.2500-28	2219-T87 or T851	NASM124696, 1.5D, thru	25TP-9
.2500-28	2219-T87 or T851	NASM124696, 1.5D, thru	25TP-10
.5000-20	2219-T87 or T851	NASM124700, 1.5D, thru	50TP-1
.5000-20	A286	H4 class 3 tapped hole, 1.5D, blind	50TP-2

C.5 Instrumentation

The instrumentation required to conduct the tests are inherent to the test facility. Measuring/test equipment with traceable calibrations to the National Institute of Standards and technology will be used to support these tests. The calibration system requirements will be per ANSI/NCSL Z540-1-1994. All test instruments will be operationally verified before each test and as required by the operating limits of the test.

C.6 Photography

Photographic coverage must document the pretest, test, and post-test inspections and conditions. Coverage is also required to illustrate test sample configurations, test performance, and anomaly and failure modes. Digital photographs of the test item and instrumentation will be taken as appropriate and necessary to adequately document pre-test tooling/fixtures, test setup, and test instrumentation. Each photograph will be labeled to identify its contents.

	NASA Engineering and Safety Center Technical Assessment Report	Document #: NESC-RP-04-092	Version: 1.0
Title: Evaluate the Performance of Loctite® as a Secondary Locking Feature for ISS Fasteners		Page #: 76 of 205	

C.7 Test Data Requirements

The following data will be required for this testing.

C.7.1 Tensile Testing

Fastener Part Number and ID number
 Fastener Diameter
 Measurement instrument calibration information
 Load-extension curves
 Johnson's 2/3rd's yield load values

C.7.2 Torque-Tension Testing

Torque transducer calibration information
 Load cell calibration information
 Test block ID number
 Fastener Part Number and ID number
 Anaerobic Type
 Torque-Load diagram

C.7.3 Break loose and Running Torque Testing

Torque transducer calibration information
 Load washer calibration information
 Test plate ID number
 Test hole number
 Torque level (100%, 75%, etc.)
 Anaerobic Type
 Installation time and date
 Cure time
 Disassembly time and date
 Break loose torque each hole
 Running torque each hole

	NASA Engineering and Safety Center Technical Assessment Report	Document #:	Version:
		NESC-RP-04-092	1.0
Title: Evaluate the Performance of Loctite® as a Secondary Locking Feature for ISS Fasteners			Page #: 77 of 205

C.8 Testing

C.8.1 Tensile Testing

Tensile testing will be conducted to determine load-extension curves for fasteners. Three fasteners of each part number NAS1352N08-16 (0.164-32), NAS1004-8A (0.250-28), and NAS1958C-32 (0.500-20) shall be tested. The tests will be conducted per the following procedures:

1. Install test fastener into test fixture.
2. Apply tensile load to failure, develop data specified in section 7.0.
3. Repeat for 9 fasteners; 3 fasteners of each size.

C.8.2 Torque-tension Testing

Torque-tension curves will be developed for the configurations specified in table 1. The tests will be conducted using EM10-OWI-MET-021 and the following:

1. Set up SPS torque-tension machine for the size fastener to be tested.
2. Sample preparation: Clean the fastener threads with MEK.
3. Install countersunk washer onto the fastener with the beveled side toward the fastener.
4. Apply activator to the fastener threads for those test configurations for which it is specified. Let the activator dry for a minimum of 15 minutes.
5. Apply anaerobic locking compound to the threads of the fastener to be tested using the droplet method. Use three drops applied every 120 degrees around the circumference of the fastener at the center of the threaded portion of the fastener, for all sizes of fasteners. Remove excess locking compound from the threads by tapping.
6. Install the fastener through the torque fixture and screw hand tight into the substrate test block to be tested.
7. Torque the fastener from the head using load control to the value specified in table 3.
8. Unload to zero and repeat 5 cycles.

Fastener No.	Size	Test Block ID	Test Load (lbs)	Torque Transducer Limit (in-lbs)	Number of Cycles
1	0.2500-28	25-1	3500	50 ft-lbs	5
2	0.2500-28	25-2	3500	50 ft-lbs	5
3	0.2500-28	25-3	3500	50 ft-lbs	5
4	0.2500-28	25-4	3500	50 ft-lbs	5
5	0.2500-28	25-5	3500	50 ft-lbs	5
6	0.2500-28	25-6	3500	50 ft-lbs	5
7	0.2500-28	25-7	3500	50 ft-lbs	5
8	0.2500-28	25-8	3500	50 ft-lbs	5
9	0.2500-28	25-9	3500	50 ft-lbs	5
10	0.2500-28	25-10	3500	50 ft-lbs	5



NASA Engineering and Safety Center Technical Assessment Report

Document #:
**NESC-RP-
04-092**

Version:
1.0

Title:

Evaluate the Performance of Loctite® as a Secondary Locking Feature for ISS Fasteners

Page #:
78 of 205

Table 3: Torque-Tension Testing Test Parameters

Fastener No.	Size	Test Block ID	Test Load (lbs)	Torque Transducer Limit (in-lbs)	Number of Cycles
11	0.2500-28	25H2-1	3500	50 ft-lbs	5
12	0.2500-28	25H2-2	3500	50 ft-lbs	5
13	0.2500-28	25H2-3	3500	50 ft-lbs	5
14	0.2500-28	25H2-4	3500	50 ft-lbs	5
15	0.2500-28	25H2-5	3500	50 ft-lbs	5
16	0.2500-28	25H2-6	3500	50 ft-lbs	5
17	0.2500-28	25H2-7	3500	50 ft-lbs	5
18	0.2500-28	25H2-8	3500	50 ft-lbs	5
19	0.2500-28	25H2-9	3500	50 ft-lbs	5
20	0.2500-28	25H2-10	3500	50 ft-lbs	5
21	0.2500-28	25H4-1	3500	50 ft-lbs	5
22	0.2500-28	25H4-2	3500	50 ft-lbs	5
23	0.2500-28	25H4-3	3500	50 ft-lbs	5
24	0.2500-28	25H4-4	3500	50 ft-lbs	5
25	0.2500-28	25H4-5	3500	50 ft-lbs	5
26	0.2500-28	25H4-6	3500	50 ft-lbs	5
27	0.2500-28	25H4-7	3500	50 ft-lbs	5
28	0.2500-28	25H4-8	3500	50 ft-lbs	5
29	0.2500-28	25H4-9	3500	50 ft-lbs	5
30	0.2500-28	25H4-10	3500	50 ft-lbs	5
31	0.2500-28	25K-1	3500	50 ft-lbs	5
32	0.2500-28	25K-2	3500	50 ft-lbs	5
33	0.2500-28	25K-3	3500	50 ft-lbs	5
34	0.2500-28	25K-4	3500	50 ft-lbs	5
35	0.2500-28	25K-5	3500	50 ft-lbs	5
36	0.2500-28	25K-6	3500	50 ft-lbs	5
37	0.2500-28	25K-7	3500	50 ft-lbs	5
38	0.2500-28	25K-8	3500	50 ft-lbs	5
39	0.2500-28	25K-9	3500	50 ft-lbs	5
40	0.2500-28	25K-10	3500	50 ft-lbs	5
1	0.1640-32	16-1	1500	200 in-lbs	5
2	0.1640-32	16-2	1500	200 in-lbs	5
3	0.1640-32	16-3	1500	200 in-lbs	5
4	0.1640-32	16-4	1500	200 in-lbs	5
5	0.1640-32	16-5	1500	200 in-lbs	5
6	0.1640-32	16-6	1500	200 in-lbs	5
7	0.1640-32	16-7	1500	200 in-lbs	5
8	0.1640-32	16-8	1500	200 in-lbs	5
9	0.1640-32	16-9	1500	200 in-lbs	5
10	0.1640-32	16-10	1500	200 in-lbs	5
1	0.5000-20	50-1	26000		5
2	0.5000-20	50-2	26000		5
3	0.5000-20	50-3	26000		5
4	0.5000-20	50-4	26000		5
5	0.5000-20	50-5	26000		5
6	0.5000-20	50-6	26000		5
7	0.5000-20	50-7	26000		5
8	0.5000-20	50-8	26000		5
9	0.5000-20	50-9	26000		5
10	0.5000-20	50-10	26000		5
11	0.5000-20	50H4-1	26000		5
12	0.5000-20	50H4-2	26000		5
13	0.5000-20	50H4-3	26000		5
14	0.5000-20	50H4-4	26000		5
15	0.5000-20	50H4-5	26000		5
16	0.5000-20	50H4-6	26000		5
17	0.5000-20	50H4-7	26000		5
18	0.5000-20	50H4-8	26000		5
19	0.5000-20	50H4-9	26000		5
20	0.5000-20	50H4-10	26000		5

	NASA Engineering and Safety Center Technical Assessment Report	Document #:	Version:
		NESC-RP-04-092	1.0
Title: Evaluate the Performance of Loctite® as a Secondary Locking Feature for ISS Fasteners			Page #: 79 of 205

C.8.3 Breakloose and Running Torque Testing

Breakloose and running torque testing will be conducted according to the following procedure:

1. Sample preparation: Clean the fastener threads with MEK.
2. Install countersunk washer onto the fastener with the beveled side toward the fastener.
3. Apply activator to the fastener threads for those test configurations for which it is specified. Let the activator dry for a minimum of 15 minutes.
4. Apply anaerobic locking compound to the threads of the fastener to be tested using the droplet method. Use three drops applied every 120 degrees around the circumference of the fastener at the center of the threaded portion of the fastener, for all sizes of fasteners. Remove excess locking compound from the threads by tapping.
5. Install fasteners to the torque values specified in table 4. One fastener in each row will be installed with a load washer to determine load level versus torque.
6. Let the locking compound cure for a minimum of 30 hours.
7. Remove the fasteners from the test plate.
8. Record the information specified in section 7.0.
9. Bag and tag all fasteners for subsequent inspection.
10. Microscopic inspection and photography of fasteners as appropriate and necessary.

Table 4: Break Loose/Running Torque Test - Installation Torque Levels								
Test Plate ID	Torque Level (in-lbs)							
	Row 1 (100%)		Row 2 (75%)		Row 3 (50%)		Row 4 (25%)	
	Col 1-8	Col 9-11	Col 1-8	Col 9-11	Col 1-8	Col 9-11	Col 1-8	Col 9-11
16TP-1	52	42	39	32	24	20	13	10
25TP-1	297	266	225	200	150	138	78	69
25TP-2	297	266	225	200	150	138	78	69
25TP-3	287	287	220	220	153	153	80	80
25TP-4	301	302	234	230	162	162	82	84
25TP-5	301	302	234	230	162	162	82	84
25TP-6	200	185	140	150	90	110	50	65
25TP-7	297	266	225	200	150	138	78	69
25TP-8	297	266	225	200	150	138	78	69
25TP-9	297	266	225	220	150	138	78	69
25TP-10	297	266	225	200	150	138	78	69
50TP-1								
50TP-2								

	NASA Engineering and Safety Center Technical Assessment Report	Document #: NESC-RP-04-092	Version: 1.0
Title: Evaluate the Performance of Loctite® as a Secondary Locking Feature for ISS Fasteners		Page #: 80 of 205	

C.8.4 Post Test

Post test operations on each bolt may begin after each bolt is tested. A post-test visual and microscopic inspection is required for each break loose and running torque test. All post-test anomalies will be reported and documented.

C.9 Reports

A final report will be written upon completion of all testing. Anomalies and objectives will be addressed and test results shall be fully documented in the report.

	NASA Engineering and Safety Center Technical Assessment Report	Document #: NESC-RP- 04-092	Version: 1.0
Title: Evaluate the Performance of Loctite® as a Secondary Locking Feature for ISS Fasteners		Page #: 81 of 205	

Appendix D. CTE Effects of Fastener Mechanical Loads

To request the data information, please go to URL:
<http://www.nasa.gov/offices/nesc/home/index.html>

	<p align="center">NASA Engineering and Safety Center Technical Assessment Report</p>	<p align="center">Document #: NESC-RP- 04-092</p>	<p align="center">Version: 1.0</p>
<p>Title: Evaluate the Performance of Loctite® as a Secondary Locking Feature for ISS Fasteners</p>		<p align="center">Page #: 82 of 205</p>	

**Appendix E. NASM1312-7 Vibration Testing Test Plan
This document was purposely left marked as Draft.**



NASA Engineering and Safety Center Technical Assessment Report

Document #:
**NESC-RP-
04-092**

Version:
1.0

Title:

Evaluate the Performance of Loctite® as a Secondary Locking Feature for ISS Fasteners

Page #:
84 of 205

LaRC-D210-01
Loctite Testing
Draft (10/21/2005)

Table of Contents

1.0	Introduction	3
1.1	Scope	3
1.2	Test Objective	4
2.0	Applicable Documents	4
3.0	Facility and Environmental Requirements	4
3.1	Safety	4
3.2	Access Restrictions	5
3.3	Required Personnel	5
3.4	Environmental	5
3.5	Lifting and Handling	5
4.0	Quality Assurance Provisions	5
4.1	Nonconformance	6
4.2	Test Failure	6
4.2.1	Failure Criteria	6
4.2.2	Procedures Following Occurrence of Failure	6
4.2.3	Failure Reporting	7
5.0	Documentation Requirements	7
5.1	“As-Run” and Redline Documents	7
5.2	Test Log	8
5.3	Disposition	8
6.0	Test Equipment	8
6.1	Facility	9
6.2	Calibration	9
6.3	Test Article	10
6.3.1	Test Article Handling	11
6.3.2	Fastener Marking	11
7.0	Vibration Test	12
7.1	Test Description	12
7.1.1	Sine-Dwell Vibration Test Parameters	12
7.1.2	Testing Sequence	12
7.2	Test Setup	13
7.2.1	Facility Preparation	13
7.2.2	Measurement and Control System Set-up	14
7.2.2.1	Sensing Instrumentation:	14
7.2.2.2	Control System Setup Parameters	15
7.2.3	Test Article Preparation	16
7.2.3.2	Test Article Axis Orientation	16
7.2.3.2	Test Fixture Adapter Plate Installation and Shaker Setup	17
7.3	Test Procedure	17
8.5	Post Test Procedures	18
8.5.1	Test Article De-installation	18
8.5.2	Facility Procedures	18
Appendix A	Test Sample Installation	19
Appendix B	Test Data Sheet	21

Draft



NASA Engineering and Safety Center Technical Assessment Report

Document #:
NESC-RP-04-092

Version:
1.0

Title:

Evaluate the Performance of Loctite® as a Secondary Locking Feature for ISS Fasteners

Page #:
85 of 205

LaRC-D210-01
Loctite Testing
Draft (2/1/2006)

1.0 Introduction

The purpose of this test is to conduct qualification testing of the use of Loctite® as a secondary locking feature in threaded fastening systems used for the International Space Station. The qualification tests are being carried out in accordance with the National Aerospace Standard NASM1312-7 “Fastener Test Methods, Method 7 – Vibration” dated August 1997. The tests are being conducted for the NASA Engineering Safety Center as part of an investigation into the use of anaerobic locking compounds in fastening systems used on the International Space Station.

The NASM1312-7 standard provides a means of qualification through accelerated vibration testing. The method incorporates the use of repeated shocks to determine the suitability of a fastener system. The time to failure and the probability of failure given a specific time will be determined as a result of this test. The measurement of failure will be the indication of relative movement of the bolt in relation to the ‘nut’ in the fastener system. The measurement of the post-test ‘break-away’ torque shall be a secondary measurement.

Three fastening systems and three fastener sizes will be tested. The fastening systems are: bolt/threaded hole, bolt/helical-coil insert, and bolt/key-locking insert. The inserts are non-locking. The three target fastener sizes are; 0.164-32, 0.250-28, and 0.500-20. The test matrix is given in Table 1.0. The torque values for the 0.500 and 0.250 inch bolts are adopted from MIL-DTL-18240F that defines the procurement specification for self-locking elements in threaded fasteners. The torque value for the 0.164 inch bolt was derived by extrapolating the seating torque values in MIL-DTL-18240F down to 0.164 inch.

Table 1.0 Test Matrix

NASM-1312-7 Test Matrix						
Configuration Designation	Number of Samples	Fastener Size	Insert/Hole Specification	Substrate	Lubricant/Locking Detail	Torque (lb-in)
1	50	0.250-28	NASM124696 Helical Coil 1.5 Dia	15-5 PH 1025 SS	Loctite 242	60
2	50	0.250-28	MS51831CA202L Key Locking 1.5 Dia	15-5 PH 1025 SS	Loctite 242	60
3	50	0.250-28	H4 class 3 tapped hole, 1.5 Dia	A286	Loctite 242	60
4	50	0.500-20	NASM124700 Helical Coil 1.5 Dia	15-5 PH 1025 SS	Loctite 271	300
5	50	0.500-20	H4 class 3 tapped hole, 1.5 Dia	A286	Loctite 271	300
6	50	0.164-32	NASM122119 Helical Coil 1.5 Dia	15-5 PH 1025 SS	Loctite 242	20

1.1 Scope

This document defines the facility vibration test requirements, test set-up, instrumentation requirements, test loads spectra, and test sequence relative to the vibration testing of various bolts with applied anaerobic thread lockers.

Draft



NASA Engineering and Safety Center Technical Assessment Report

Document #:
**NESC-RP-
04-092**

Version:
1.0

Title:

Evaluate the Performance of Loctite® as a Secondary Locking Feature for ISS Fasteners

Page #:
86 of 205

LaRC-D210-01
Loctite Testing
Draft (10/21/2005)

1.2 Test Objective

In general, the objective of the qualification test is to determine the reliability of using an anaerobic locking compound as a secondary locking mechanism through vibration testing.

2.0 Applicable Documents

The following documents apply to this procedure to the extent specified herein. Unless a specific issue or revision is listed, the applicable issue shall be that in effect on the date of these operations. In conflicts between the listed documents and the contents of this procedure, this procedure shall prevail.

LMS-CP-0506	Selection Use and Control of Inspection, Measuring, and Test Equipment
LMS-OP-5509	Aerospace Systems Environmental Testing
LMS-CP-5510	Aerospace Systems Change Control within Systems Engineering
LMS-TD-5582	Vibration Laboratory Local Organization Instruction
LPR-1740.2	Facility Safety Requirements
LPR 1740.5	Procedure for Cleaning of Systems and Equipment for Oxygen Services
NPD 8621.1A	NASA Mishap Reporting and Investigation Policy
NASMI312-7	Fastener Test Methods, Method 7, Vibration
MAO106-333	Application of Locking and Retaining Compound to Threaded Electrical Hardware and Mechanical fasteners
STP-2009B	Locking and Sealing Compounds, Applications
MIL-DTL-18240F	Detail Spec. Fastener Element, Self-locking, Threaded Fasteners, 250 F Max.

3.0 Facility and Environmental Requirements

The following subsections detail general facility and environmental requirements governing this procedure.

3.1 Safety

All personnel are responsible for maintaining a safe work environment. The Test Engineer and Test Operators shall assure that appropriate safe practices are implemented during these operations.

The Technical Project Engineer has final authority over safety provisions pertaining to the test article. The respective Facility Safety Head has the final authority over safety provisions of the facilities used for this test.

Draft



NASA Engineering and Safety Center Technical Assessment Report

Document #:
**NESC-RP-
04-092**

Version:
1.0

Title:

Evaluate the Performance of Loctite® as a Secondary Locking Feature for ISS Fasteners

Page #:
87 of 205

LaRC-D210-01
Loctite Testing
Draft (10/21/2005)

3.2 Access Restrictions

Access to the test areas shall be limited to test personnel and designated project personnel for the duration of this procedure. A list of required personnel is contained in Section 3.3.

3.3 Required Personnel

The following personnel are required for the performance of this procedure:

- a. One Test Engineer
- b. One Vibration Test Operator
- c. One Mechanical Technician
- d. Technical Project Engineer

3.4 Environmental

Standard laboratory conditions of atmospheric temperature (77 +/- 18 °F) pressure (0.8 to 1.0 bar), and humidity (20 to 80 percent) are acceptable for the operations defined herein. Temperature and humidity shall be recorded in the test-log at the start end finish of each test day. Other than test article handling requirements, no facility contamination control provisions are required for the operations defined herein.

3.5 Lifting and Handling

The test article and GSE are to be considered non-critical lift hardware. Lifting and handling operations shall be controlled by criteria provided in LPR 1740.2.

4.0 Quality Assurance Provisions

The following requirements and procedures are to be read, understood, and adhered to throughout the testing in this procedure. If any requirement or procedure is not understood, contact the Test Engineer for clarity prior to continuing with any test operation.

Responsibilities

- a. The Test Engineer and Test Operator are responsible for implementing the QA provisions of this plan
- b. The Test Engineer shall verify that the proper revision of this plan is used.
- c. The Test Engineer shall assure that the proper "As-Run Copy" has been prepared and is used for the operations defined herein.
- d. The Test Engineer shall assure that the proper "redlining" practices are used as described in Section 5.1.
- e. The Test Engineer and Test Operator shall verify that calibration is current and will not expire for the duration of this test for all measuring equipment used for the operations defined herein.

Draft

	NASA Engineering and Safety Center Technical Assessment Report	Document #: NESC-RP-04-092	Version: 1.0
Title: Evaluate the Performance of Loctite® as a Secondary Locking Feature for ISS Fasteners			Page #: 88 of 205

LaRC-D210-01
Loctite Testing
Draft (10/21/2005)

- f. The Test Engineer shall initial log entries, procedural changes, and data sheets, as appropriate, to attest to the proper completion of these operations.
- g. The Test Operator shall assure that all handling and lifting GSE are certified and that evidence of the current certification is visibly affixed.
- h. The Test Engineer and Test Operator shall verify test set-ups, handling and lifting, and GSE installation prior to test or mechanism assisted lifts or moves.

4.1 Nonconformance

A nonconformance is a condition or characteristic of the test software, or test equipment that does not conform to drawings or other specifications. For the test article, a nonconformance is a condition or characteristic that does not conform to the as-built configuration. All non-conformances shall be recorded in accordance with Section 4.2.3.

4.2 Test Failure

Test failure is any event that deviates from planned procedures, exceeds normal variations, or generates unexpected data. Test failures shall be divided into three types of failures; test article failures, test anomalies, or mishaps. These failures are defined in Section 4.2.1, the failure procedures are defined in Section 4.2.2, and the failure documentation is specified in Section 4.2.3.

4.2.1 Failure Criteria

- a. A test article failure is any event not due to human error, test equipment error, or procedural error that results in damage to the test article. Test article damage shall include but not be limited to joint failures, loose parts, connector failures, structural failures, and structural performance failures.
- b. A test anomaly is any event that is the result of human error, test equipment error, or procedural error that does not affected the test article.
- c. A mishap, as defined in NPD 8621.1A, is any event that is caused by human error, test equipment error, or procedural error that results in personnel injury or damage to the facility, or gross damage to the test article.

4.2.2 Procedures Following Occurrence of Failure

During testing the Technical Project Engineer has full authority over issues or safety concerns pertaining to the test article. However, the facility safety head has full authority over issues or safety concerns pertaining to the test facility. The Technical Project Engineer shall be informed of all failures (test article, test anomaly, or mishap).

- a. Upon the occurrence of a failure, the procedure shall be terminated in an orderly and safe manner.
- b. The Test Engineer shall record each failure in accordance with Section 4.2.3. The Test Engineer shall review the failure, and shall inform the Technical Project Engineer that a failure has occurred.

Draft

	NASA Engineering and Safety Center Technical Assessment Report	Document #: NESC-RP-04-092	Version: 1.0
Title: Evaluate the Performance of Loctite® as a Secondary Locking Feature for ISS Fasteners			Page #: 89 of 205

LaRC-D210-01
Loctite Testing
Draft (10/21/2005)

- c. Minor troubleshooting may be done to assess the failure; however, no disassembly, instrument reconfiguration, software reconfiguration, or other actions that present a risk to the test article or present a risk of losing the failure mode, shall be allowed.
- d. If the failure is a test anomaly, corrective action shall be taken and documented on the test log. Testing may continue with the concurrence of the Technical Project Engineer, Test Engineer, and Test Operator. Their approval shall be indicated by placing their initials and the current date and time into the test-log. All troubleshooting steps and results shall be recorded in the test log.
- e. If the failure is a mishap, the following contacts shall be notified:

Systems Integration and Test Branch Head,	Richard Foss
	Extension: 47049
	Home Phone: 757-357-0380
Technical Project Engineer	Extension: 757-864-4359
Emergency Dispatch Office	Extension 911 or 45600

Until the proper emergency response personnel arrive, the test personnel shall limit all access to the test facility, and they shall ensure that no disassembly, instrument reconfiguration, software reconfiguration, or other actions that present a risk to the test article or present a risk of losing the failure mode be performed.

- f. If the failure is a test article failure, then the Test Engineer shall notify the Technical Project Engineer of the failure. Testing may continue at the discretion of the Technical Project Engineer with the concurrence of the Test Engineer. Their approval shall be indicated by placing their initials and the current date into the test-log. All troubleshooting steps and results shall be recorded in the test log.

4.2.3 Failure Reporting

All failures are to be documented in the test-log.

5.0 Documentation Requirements

The following requirements are to be read, understood, and adhered to throughout the testing in this procedure. If any requirement is not understood, contact the Test Engineer for clarity prior to continuing with any test operation.

5.1 “As-Run” and Redline Documents

Prior to any operations governed by this procedure, one copy of this document shall be marked “AS-RUN COPY”. All pertinent data taken during the run shall be recorded in this copy.

Any changes identified during the performance of this procedure shall be redlined into the “As-Run Copy”. The Test Engineer, Test Operator, and Project Representative shall indicate their approval by placing their initials and the current date next to each redline before it is applied. Changes to the test criteria or basic objective of this test plan are not allowed without the re-issue of this document.

Draft

	NASA Engineering and Safety Center Technical Assessment Report	Document #: NESC-RP-04-092	Version: 1.0
Title: Evaluate the Performance of Loctite® as a Secondary Locking Feature for ISS Fasteners		Page #: 90 of 205	

LaRC-D210-01
Loctite Testing
Draft (10/21/2005)

Running a redlined procedure shall require written authorization by the Technical Project Engineer, Test Engineer, and Test Operator.

5.2 Test Log

The Test Engineer shall maintain a test log for the operations governed by this procedure. As a minimum the test log shall include:

- a. A chronological listing of all activities and related events that occurred during the performance of this procedure.
- b. Test Data Sheets (Appendix B) generated during the course of testing
- c. A detailed discussion of any procedural changes.
- d. A detailed discussion of any changes to the test article made during this procedure.
- e. A detailed discussion of authorized activities not originally planned.
- f. A detailed discussion of any test failures.

5.3 Disposition

When the prescribed operations are completed (including failed and aborted tests), the "As-Run Copy," test log, and all associated data shall be reviewed by the Test Engineer.

Following review by the Technical Project Engineer and Test Engineer, a test report shall be prepare and forwarded to the Technical Project Engineer.

Formal revision and re-issue of this document, to incorporate redlines, shall be accomplished in accordance with LMS-CP-5510.

6.0 Test Equipment

The following sections list equipment required for the performance of this procedure. The list is provided for the convenience of the Test Engineer and Test Operator, so that arrangements may be made for the availability and calibration of equipment prior to the test. Equivalent or better equipment may be substituted at the discretion of the Test Engineer. A complete list of equipment used during this procedure including part numbers, equipment control numbers, serial numbers, and calibration dates shall be recorded in the test log.

Draft



NASA Engineering and Safety Center Technical Assessment Report

Document #:
**NESC-RP-
04-092**

Version:
1.0

Title:

Evaluate the Performance of Loctite® as a Secondary Locking Feature for ISS Fasteners

Page #:
91 of 205

LaRC-D210-01
Loctite Testing
Draft (10/21/2005)

6.1 Facility

Table 6.1 Equipment list

Description	QTY	Manufacturer	Model / Part Number	Cal. Dates
Shaker Equipment:				
Unholtz-Dickie T-1000 Shaker	1	Ling	308V	NA
Loctite Fixture (drawing 124672)	1	NASA	NA	NA
2" Aluminum Test Fixture Adapter	1	NASA	NA	NA
Sensors:				
Control Accelerometer	1	PCB	352C22	3/24/2006
Displacement Laser System (analog)	1	NASA	NA	NA
Accel. cable (micro-dot to BNC)	1	PCB	NA	NA
Dampening material	1	NASA	NA	NA
Torque Wrench				
Torque Wrench				
Signal Conditioning System:				
Chassis/Power supply	1	PCB	441A01	NA
16-Channel Signal Conditioning	2	PCB	442A122	10/10/2006
Control System DAS:				
HP PC Computer	1	HP	2099110	NA
HP VXI System Mainframe	1	HP	1421B	NA
HP VXI Interface	1	Agilent	E8491B	NA
HP 8 Channel Input Module	1	HP	1432A	6/20/2005
Two Channel Digitized Scanner	1	Agilent	E1434A	3/21/2007
M+P International Vib2000 Software	1	M+P International	Ver. 2.8	NA
Oscilloscope:				
4 channel digital scope	1	Tektronix	TDS-2014	NA

6.2 Calibration

Selection and use of measurement equipment used for the operations defined herein shall be in accordance with LMS-CP-0506.

Draft



Title:

**Evaluate the Performance of Loctite® as a Secondary
Locking Feature for ISS Fasteners**

Page #:
92 of 205

LaRC-D210-01
Loctite Testing
Draft (10/21/2005)

6.3 Test Article

The test fixture is intended for the testing of threaded fasteners. The fixture conforms to the configuration and dimensional requirements specified in NASM1312-7. As shown in figure 6.1, the fixture consists of a static fixture that is bolted to a fixture/shaker adapter plate. Several cylindrical collar/nut sub-assemblies are contained within the static fixture. The collar/nut assemblies are sized to slide vertically within the static fixture. During testing the collar/nut assembly will bounce off the top and bottom of the slot providing a shock excitation to the fastener. Figure 6.2 shows a typical collar/nut assembly using a bolt/insert combination. The bolt passes through the collar into a modified washer/nut part that holds an insert. The test article part list is given in Table 6.2.

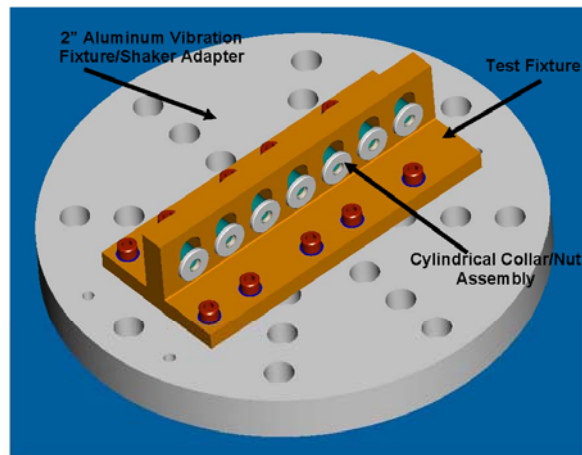

Figure 6.1 Fastener fixture in the test configuration

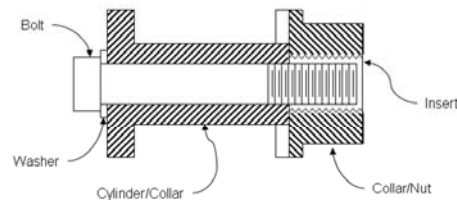

Figure 6.2 Typical sectional view of the collar/nut assembly

Draft



NASA Engineering and Safety Center Technical Assessment Report

Document #:
**NESC-RP-
04-092**

Version:
1.0

Title:

Evaluate the Performance of Loctite® as a Secondary Locking Feature for ISS Fasteners

Page #:
93 of 205

LaRC-D210-01
Loctite Testing
Draft (10/21/2005)

Table 6.2 Test Article Part List

Item	QTY	Document Number	Comment
0.250" Static Fixture	1	DWG 1246177	
0.250" Collar	11	DWG 1246177	
0.250-28 Bolt	150	NAS1004-24A	¼-28 x 2" bolt
0.250 Washer	150	AN960C416	¼ inch flat washer
0.250-28 Nut	50	DWG 1246177	Helicoil Insert
0.250-28 Nut	50	DWG 1246177	Key-Locking Insert
0.250-28 Nut	50	DWG 1246177	Straight Thread Nut
0.500" Static Fixture	1	DWG 1246270	
0.500" Collar	7	DWG 1246271	
0.500-20 Bolt	100	NAS1008-27A	½-20 x 2.5" bolt
0.500 Washer	100	AN96C816	½ inch flat washer
0.500-20 Nut	50	DWG 1246271	Helicoil Insert
0.500-20 Nut	50	DWG 1246271	Straight Thread Nut
0.164" Static Fixture	1	DWG 1246276	
0.164" Collar	7	DWG1246577	
0.164-32 Bolt	50	NAS1352N-08-24	8-32 x 1.5" bolt
0.164 Washer	50	AN960-C8	#8 flat washer
0.153-32 Nut	50	DWG 1246577	Helicoil Insert
Loctite	3	Loctite 242	Blue, medium strength
Loctite	3	Loctite 271	Red, high strength
Loctite Primer	10	Loctite 7471	Prime T, aerosol can
MEK			

6.3.1 Test Article Handling

No facility contamination control requirements are defined for this test. However, care shall be taken when handling cleaned part surfaces. Gloves shall be worn when handling cleaned parts.

6.3.2 Fastener Marking

Fasteners and nuts shall be individually bagged and tagged at the completion of each test run. As a minimum the following shall be recorded on each tag:

- a. Date and time of test run
- b. Unique tag identification number (lined to the Test Data Sheet)
- c. Test run ID (linked to the test log)
- d. Bolt size and nut part number

Draft



NASA Engineering and Safety Center Technical Assessment Report

Document #:
**NESC-RP-
04-092**

Version:
1.0

Title:

Evaluate the Performance of Loctite® as a Secondary Locking Feature for ISS Fasteners

Page #:
94 of 205

LaRC-D210-01
Loctite Testing
Draft (10/21/2005)

7.0 Vibration Test

The following requirements and procedures are to be read, understood, and adhered to throughout the testing in this procedure. If any requirement or procedure is not understood, contact the Test Engineer for clarity prior to continuing with any test operation.

7.1 Test Description

Various fastener types and sizes (0.164, 0.25, and 0.5) shall be subjected to a qualification test specified in NASM1312-7. All vibration tests shall be performed on the Unholtz-Dickie Model T-1000 environmental shaker located in building 1250, room 184 at the NASA Langley Research Center. Testing shall be performed with the shaker configured for vertical operations. The vibration input for the fastener testing shall be a sinusoidal waveform at a frequency of 1750 to 1800 cycles per minute (~30 Hertz) with amplitude of 0.450 ± 0.015 inches (peak to peak).

The fastener test setup shall be instrumented with one uni-axial accelerometer used for feedback control. The displacement amplitude of the test article shall be verified using an optical based displacement measurement system. Failure of a fastener shall be defined as relative motion between the bolt-head and the collar assembly. Torque stripping and witness marks shall be used as an aid to determine relative motion.

7.1.1 Sine-Dwell Vibration Test Parameters

The test levels, derived from NASM1312-7, for the sine-dwell vibration test are given in Table 7.1. The vibration levels are the same for each fastener set specified in test matrix given in Table 1.0.

Table 7.1 NASM1312-7 Test Parameters

Parameter	Units	Level
Frequency, min	Hz	29.17
Frequency, max	Hz	30.00
Amplitude, pp	in	0.450
Amp. Tolerance	in	± 0.015

The duration of each test shall be determined during each test by performing visual inspections every one thousand cycles (~33 seconds) until all fasteners have failed or the total accumulated test time exceeds thirty thousand cycles (~1000 sec).

7.1.2 Testing Sequence

The test sequence is shown in Figure 7.1. The Test Engineer, with the consent of the Technical Project Engineer, may modify this sequence to suite testing needs.

Draft



NASA Engineering and Safety Center Technical Assessment Report

Document #:
**NESC-RP-
04-092**

Version:
1.0

Title:

Evaluate the Performance of Loctite® as a Secondary Locking Feature for ISS Fasteners

Page #:
95 of 205

LaRC-D210-01
Loctite Testing
Draft (10/21/2005)

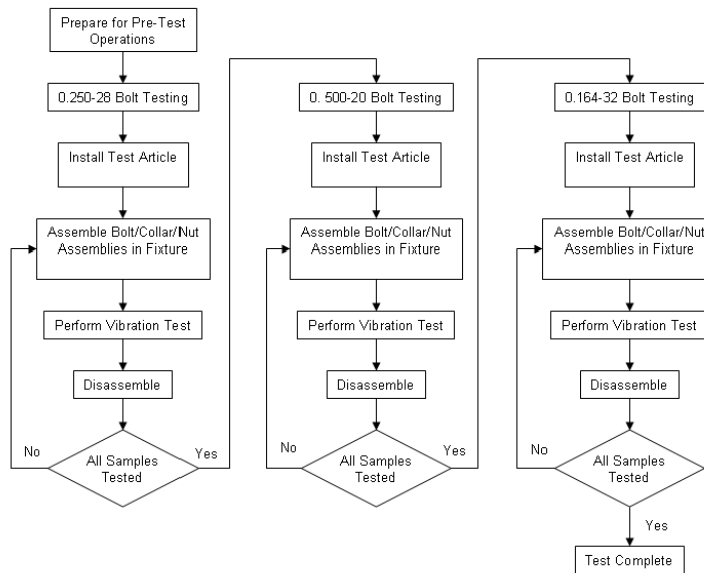

Figure 7.1 Flow Chart Detailing the Testing Process

7.2 Test Setup

The test article shall be mounted to an adapter plate that is mounted to the shaker. The shaker shall be configured for vertical operations. The measurement and control system shall be setup in accordance with Section 7.2.2. The test article shall be prepared in accordance with Section 7.2.3.

7.2.1 Facility Preparation

The Test Operator shall insure that the test facility is ready for operations by certifying the following:

- Verify that all appropriate instrumentation is available, in working order, and, where appropriate, calibrated.
- Verify facility-lifting devices used in this procedure are certified.

Test Facility ready for test: _____ Date: _____

Test Operator

Draft¹³



NASA Engineering and Safety Center Technical Assessment Report

Document #:
NESC-RP-04-092

Version:
1.0

Title:

Evaluate the Performance of Loctite® as a Secondary Locking Feature for ISS Fasteners

Page #:
96 of 205

LaRC-D210-01
Loctite Testing
Draft (10/21/2005)

7.2.2 Measurement and Control System Set-up

The data acquisition and control system setup configuration is shown in Figure 7.2. The primary data acquisition system (DAS) is the shaker control system. This system is used to control all aspects of the test. The feedback control acceleration and displacement measurement signals shall be routed through appropriate signal conditioning to the control system DAS.

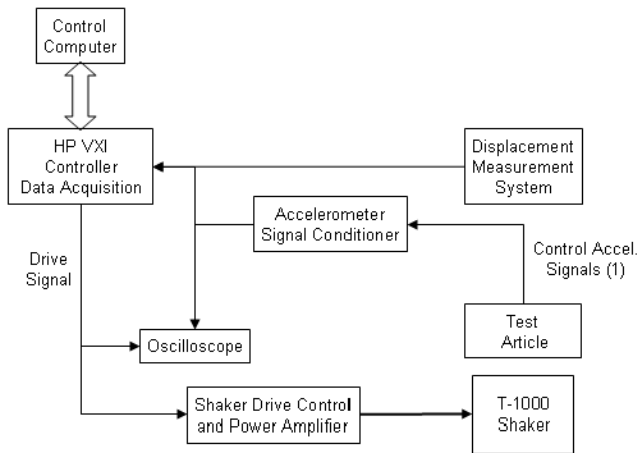

Figure 7.2 Data Acquisition and Control System Configuration

7.2.2.1 Sensing Instrumentation:

One PCB model T352M92 10mv/g accelerometer shall be mounted to the two inch aluminum vibration adapter fixture. To isolate the control accelerometer from high-frequency shock response, the accelerometer shall be installed with isolation material. The isolation material shall be suitable for rejecting response frequencies above 1000 Hz. However, the application of the isolation shall not reduce the mounted resonance of the sensor below 300 Hz. The control accelerometer shall be oriented with the sensing axis in the vertical direction. The general location of the control accelerometer are shown in Figure 7.3.

Draft



NASA Engineering and Safety Center Technical Assessment Report

Document #:
**NESC-RP-
04-092**

Version:
1.0

Title:

Evaluate the Performance of Loctite® as a Secondary Locking Feature for ISS Fasteners

Page #:
97 of 205

LaRC-D210-01
Loctite Testing
Draft (10/21/2005)

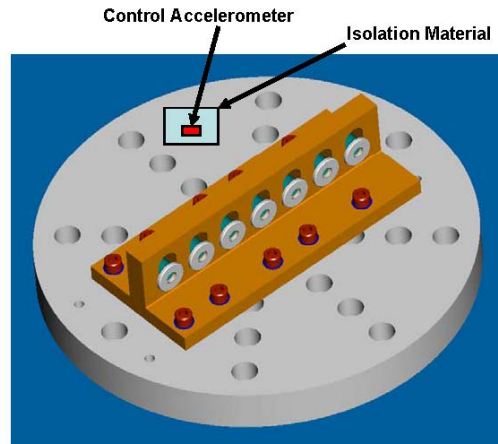

Figure 7.3 Control Accelerometer Locations

The displacement measurement system shall be setup as per manufacturer instructions. The system shall be set to acquire the vertical displacement of the static fixture.

7.2.2.2 Control System Setup Parameters

The data acquisition and control system shall be set consistent with performing sine-dwell environmental tests. The control system shall be configured with the parameters given in Table 7.2. System default parameters shall be used for parameters not given in Table 7.2.

Draft



NASA Engineering and Safety Center Technical Assessment Report

Document #:
**NESC-RP-
04-092**

Version:
1.0

Title:

Evaluate the Performance of Loctite® as a Secondary Locking Feature for ISS Fasteners

Page #:
98 of 205

LaRC-D210-01
Loctite Testing
Draft (10/21/2005)

Table 7.2 Control System Setup Parameters

Dwell Parameters	Value	Units
Dwell type	Fixed	-
Frequency	29.2	Hz
Amplitude	0.225	in (0-peak)
Duration	1000	cycles
Selfcheck level	-6	dB
Startup time	1	sec
Shutdown time	0.17	sec
Startup tolerance	1.5	dB
Control Strategy	Average	-
Damping	4	-
Limits		
Upper alarm	0.656	dB
Lower alarm	-0.678	dB
Upper abort	1	dB
Lower abort	-1	dB
Control Channel		
Meas. Method	Filtered	-
Abort Limit	25	g

7.2.3 Test Article Preparation

Prior to the start of the vibration testing the test article shall be certified ready for test operations by confirming the following:

- Visually inspect the test article for damage or defects,
- Prepare fastener samples by cleaning the bolts and 'nut' assemblies to a Level A cleanliness level as per LPR 1740.5 (less than 1.0 mg/(0.1m²) NVR).
- Verify parts specified in Table 6.2 are available and ready for test.

Test Article ready for test: _____ Date: _____

Technical Project Engineer

7.2.3.2 Test Article Axis Orientation

There is only one axis for this test, the vertical axis aligned thru the vertical center of the slots in the static fixture. This axis shall correspond to the axis of motion.

Draft



NASA Engineering and Safety Center Technical Assessment Report

Document #:
**NESC-RP-
04-092**

Version:
1.0

Title:

Evaluate the Performance of Loctite® as a Secondary Locking Feature for ISS Fasteners

Page #:
99 of 205

LaRC-D210-01
Loctite Testing
Draft (10/21/2005)

7.2.3.2 Test Fixture Adapter Plate Installation and Shaker Setup

1. Verify that the shaker is configured for vertical shaker operation as per LMS-TD-5582.
2. Visually inspect for and remove any debris in the shaker head mounting holes.
3. Mount the two inch aluminum vibration test fixture to the top of the shaker armature with twenty-eight (28) 1/2-13 x 1.75" SHCS and washers. Torque screws to **65 ft-lbs.**
4. Mount the control accelerometer in accordance with Section 7.2.2.1.

Verify that the T-1000 environmental shaker is setup for vertical shaker operations and the fixture adapter plate and control accelerometer are properly installed.

TE

TO



7.3 Test Procedure

As shown in the test matrix of Table 1.0, there are 6 different test configurations involving three different fastener sizes. Each configuration will undergo the same qualification vibration test. The sequence of testing these fasteners is shown in Figure 7.1. The following present a generic test procedure to be implemented for each test configuration.

1. Verify that the control accelerometer is attached to the two inch aluminum vibration fixture.
2. Install the test fixture using all 1/2-13 x 1.75" SHCS and washers provided for by the fixture. Torque screws to **65 ft-lbs.**
3. Install the displacement laser system and verify it is operating properly
4. Verify the proper sine-dwell test parameters, as describe in Section 7.2.2.2, has been correctly specified in the vibration control system.
5. Perform a sine-dwell pre-test to verify shaker operation
6. Install the sample fasteners in accordance with Appendix A.
7. Photograph test setup.
8. Perform the sine-dwell vibration test for a duration of 1000 cycles.
9. Maintain shaker control system in an operating condition.

Draft

	NASA Engineering and Safety Center Technical Assessment Report	Document #: NESC-RP-04-092	Version: 1.0
Title: Evaluate the Performance of Loctite® as a Secondary Locking Feature for ISS Fasteners			Page #: 100 of 205

LaRC-D210-01
Loctite Testing
Draft (10/21/2005)

10. Visually inspect the sample fasteners for failures. If failures have occurred:
 - a. Record failures on data sheet, Appendix B.
 - b. Remove failed fastener from fixture recording the 'break-away' torque.
 - c. Bag and tag the fastener in accordance with Section 6.3.2
11. Inspect the control accelerometer data to insure compliance with Section 7.1.1.
12. If total accumulated test time is less that 30000 cycles:
 - a. Reset shaker control system
 - b. Repeat step 7 through 10.
13. If total accumulated test time is equal to or greater that 30000 cycles:
 - a. Test matrix configuration step competed.
 - b. Remove remaining sample fasteners from fixture and record the duration and break-away torque on data sheet.
 - c. Bag and tag the remaining fasteners in accordance with Section 6.3.2

8.5 Post Test Procedures

8.5.1 Test Article De-installation

Remove the test fixture from the adapter plate. Deliver the test article and fastener samples to the Technical Project Engineer.

8.5.2 Facility Procedures

Shutdown test equipment and inspect facility for maintenance.

Draft

	NASA Engineering and Safety Center Technical Assessment Report	Document #: NESC-RP-04-092	Version: 1.0
Title: Evaluate the Performance of Loctite® as a Secondary Locking Feature for ISS Fasteners			Page #: 101 of 205

LaRC-D210-01
Loctite Testing
Draft (10/21/2005)

Appendix A Test Sample Installation

This procedure below shall be used for the installation of the fastener samples into the test fixture. This is a generic procedure that shall be followed for each configuration of the test matrix of Table 1.0. An Exploded view of the test article is shown in figure A-1.

1. Verify that the test specimens (fasteners and nuts) have been properly cleaned as per Section 7.2.3
2. Select fasteners and record lot number information on the Test Data Sheet.
3. Insert the fastener cylindrical collars into the slotted portions of the test fixture.
4. Apply activator (Loctite Primer 7471) to external and internal mating surfaces of the fasteners and 'nuts'. Allow activator to dry for approximately 10 to 15 minutes before mating parts. Record drying time on the Test Data Sheet.
5. Install a flat washer onto the test specimen, and insert the test specimen into the collar of the test fixture.
6. Thoroughly shake the anaerobic locking compound (Loctite 242/271) before applying to thread surfaces.
7. Apply the anaerobic locking compound to 100% of the threads of the fasteners to be tested, as per MAO106-333. Use the droplet method to apply the locking compound to the fastener. With this method three drops shall be applied every 120 degrees around the circumference of the fastener at the center of the length of the thread for all sizes of fasteners. Any excess locking compound should be removed. Loctite 242 shall be applied to the #8 and 1/4" fasteners, and Loctite 271 shall be applied to the 1/2" fasteners.
8. Immediately install insert nut onto the threaded portion of the test specimen.
9. Torque the fastener and nut assemble to the appropriate torque value specified in Table A-1. Record the installation torque on the Test Data Sheet.
10. Apply a torque strip and scribe a witness mark onto the test specimen. These marks shall be used to verify if the fastener has rotated as a result of the vibration test.
11. Let thread locking compound cure for approximately 24 hours before testing. Record the cure time on the Test Data Sheet before testing.

Draft



NASA Engineering and Safety Center Technical Assessment Report

Document #:
**NESC-RP-
04-092**

Version:
1.0

Title:

Evaluate the Performance of Loctite® as a Secondary Locking Feature for ISS Fasteners

Page #:
102 of 205

LaRC-D210-01
Loctite Testing
Draft (10/21/2005)

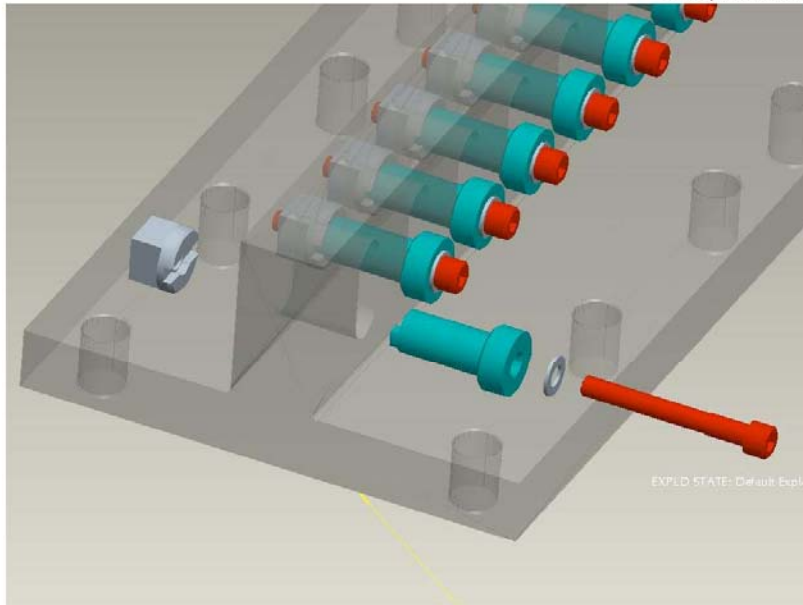



Figure A-1 Test article assembly

Table A-1 Assembly Torques

Fastener Size	Seating Torque (in-lb)
0.164-32	20
0.250-28	60
0.500-20	300

Draft

	NASA Engineering and Safety Center Technical Assessment Report	Document #: NESC-RP- 04-092	Version: 1.0
Title: Evaluate the Performance of Loctite® as a Secondary Locking Feature for ISS Fasteners		Page #: 103 of 205	

LaRC-D210-01
 Loctite Testing
 Draft (10/21/2005)

Appendix B Test Data Sheet

See next page.

Draft



NASA Engineering and Safety Center Technical Assessment Report

Document #:
**NESC-RP-
04-092**

Version:
1.0

Title:

Evaluate the Performance of Loctite® as a Secondary Locking Feature for ISS Fasteners

Page #:
104 of 205

LaRC-D210-01
Loctite Testing
Draft (2/1/2006)

NASM1312-7 Vibration Test Data Sheet

Test Configuration Number _____ Test Operator _____
Bolt Identification _____ Test Engineer _____
Insert Identification _____ Project Engineer _____

Fastener Installation Vibration Test
Date _____ Date _____
Time _____ Time _____
Temperature _____ Temperature _____
Humidity _____ Humidity _____

Fastener Number	Bolt Lot #	Insert Lot #	Primer Set Time (sec)	Installation Torque (in-lbs)	Loctite Cure Time (hr)	Cycles-to Failure	Break-away Torque (in-lbs)	Bag Identification	Comments
1									
2									
3									
4									
5									
6									
7									
8									
9									
10									
11									

Draft

	NASA Engineering and Safety Center Technical Assessment Report	Document #: NESC-RP- 04-092	Version: 1.0
Title: Evaluate the Performance of Loctite® as a Secondary Locking Feature for ISS Fasteners		Page #: 105 of 205	

Appendix F. Comparison of Secondary Locking Features for Threaded Inserts, July 2007

**The author of this document served as a team member on this
NESC assessment under contract number NNL07AA00B.**

	NASA Engineering and Safety Center Technical Assessment Report	Document #: NESC-RP-04-092	Version: 1.0
Title: Evaluate the Performance of Loctite® as a Secondary Locking Feature for ISS Fasteners		Page #: 106 of 205	

Comparison of Secondary Locking Features for Threaded Inserts – Summer 2007

D. P. Hess, Ph.D.

July 2007

Introduction

This document reports on tests of loosening of threaded fasteners subjected to dynamic shear. Specifically, a series of tests are performed to provide a comparative assessment of the locking performance (or loosening resistance) of NAS1004 ¼-28 UNJF-3A hex head screws with:

1. Standard free-running Heli-Coil inserts with Braycote 601 EF high vacuum grease
2. Locking Heli-Coil inserts with Braycote 601 EF high vacuum grease, and
3. Standard free-running Heli-Coil inserts with Loctite 242 threadlocker.

The tests are performed on a DIN 65151 or Junker type [1-4] test machine which provides dynamic shear loading. This study complements the work of Elliot [5] which compares the performance of the same threaded product groups using the MIL-STD-1312-7A vibration test [6].

Apparatus

A schematic and photograph of the test machine are shown in Figures 1 and 2. It consists of a top plate clamped to a rigid fixed base through a threaded insert using a test screw. Roller bearings are placed between the top plate and the fixed base to minimize sliding friction and to prevent galling. Cyclic shear load is applied to the top plate by an arm connected to an adjustable eccentric which is driven by a 5 HP AC motor through an adjustable pulley arrangement. Load cells are used to measure screw preload and the shear force acting on the top plate. In addition, the transverse displacement of the plate is measured through an LVDT placed at the end of the plate.

The test machine has built-in digital displays for shear force, preload and transverse displacement. A multi-channel data acquisition system is used to record the time traces of these variables.

Test Specimens

Tests are performed to provide a comparative assessment of the locking performance of NAS1004 ¼-28 UNJF-3A hex head screws [7] with:

1. Standard free-running Heli-Coil inserts with Braycote 601 EF high vacuum grease
2. Locking Heli-Coil inserts with Braycote 601 EF high vacuum grease, and
3. Standard free-running Heli-Coil inserts with Loctite 242 threadlocker.



NASA Engineering and Safety Center Technical Assessment Report

Document #:
**NESC-RP-
04-092**

Version:
1.0

Title:

Evaluate the Performance of Loctite® as a Secondary Locking Feature for ISS Fasteners

Page #:
107 of 205

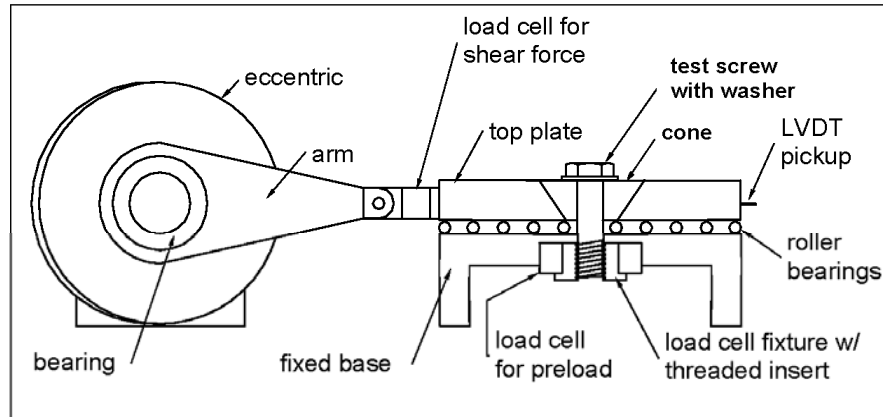

Figure 1 Schematic of test machine.



Figure 2 Photograph of test machine.



NASA Engineering and Safety Center Technical Assessment Report

Document #:
**NESC-RP-
04-092**

Version:
1.0

Title:

Evaluate the Performance of Loctite® as a Secondary Locking Feature for ISS Fasteners

Page #:
108 of 205



Figure 3 Photograph of representative test specimens.

Twelve tests are run for each of the three configurations or locking levels for a total of thirty-six tests. The specifications for the screws, washers and Heli-Coil inserts used in these tests are as follows (for manufacturers and lot numbers see Appendix A):

1. Thirty-six NAS1004-29A, ¼-28 UNJF-3A, 2.356 inch long, hex head screws, made of A286 stainless steel [7]
2. Thirty-six NAS1149-C0463R washers for ¼ inch screw made of corrosion resistant steel with a passivated finish [8]
3. Twenty-four MS124696, 0.375 inch long, standard, free-running Heli-Coil inserts, made of 304 stainless steel [9]
4. Twelve MS21209-F4-15, 0.375 inch long, locking Heli-Coil inserts, made of 304 stainless steel [9]

A new screw, washer and Heli-Coil insert is used for each test. In the test machine, a test screw clamps the top plate to the fixed base through a washer, a cone and load cell fixture as shown in Figure 1. The cone sets in the top plate and the load cell fixture sets in the preload load cell. A test Heli-Coil insert is installed into the load cell fixture.

A separate cone and load cell fixture is used for each test. These thirty-six test cones and load cell fixtures provided by Elliot [5] are made of 15-5 stainless steel and heat treated to RC35. The flat surfaces are finished to 32µin. The cones have thru-holes and the load cell fixtures have tapped holes ready for Heli-Coil installation. Figure 3 shows a photograph of representative test specimens.

	NASA Engineering and Safety Center Technical Assessment Report	Document #: NESC-RP-04-092	Version: 1.0
Title: Evaluate the Performance of Loctite® as a Secondary Locking Feature for ISS Fasteners			Page #: 109 of 205

The screw length of 2.356 inch is selected [7] to provide complete engagement with the 0.375 inch long Heli-Coil inserts. The washers [8] are 0.063 ± 0.006 inch thick. The distance between the top of the cone and the top of the load cell fixture in the test machine (see Figure 1) is 1.8 inch. The Heli-Coil inserts are installed 0.75P to 1.5P (0.0268 to 0.0536 inch) below the top surface of the load cell fixture. Thus, 2.356 inch minus 0.057 to 0.069 inch minus 1.8 inch minus 0.0268 to 0.0536 inch leaves 0.433 to 0.472 inch of the screw for engagement. The threaded length of the screw is 0.544 inch [7]. Screw stretch with a preload of 1,200 and 2,400 lbs is about 0.002 and 0.004 inch, respectively.

Pre-cleaning Used Cone and Fixtures

The 36 cones and 36 load cell fixtures used in these tests were used once in previous tests during November and December 2006. These parts are pre-cleaned to remove Loctite threadlocker and Braycote grease as follows:

1. Remove Heli-Coils from load cell fixtures using Heli-Coil removal tool
2. Clean all cones and load cell fixtures in ultrasonic cleaner with MEK (methyl ethyl ketone) for 3 minutes
3. Run ¼-28 H2 Heli-Coil thread tap through pre-tapped load cell fixtures and wipe away any grease or adhesive
4. Replace MEK and repeat step 2

Installing Heli-Coil Inserts

The standard free-running and locking Heli-Coil inserts are installed in the load cell fixtures following manufacturer's instructions [9] and using Heli-Coil installation and tang break-off tools.

The Heli-Coil installation procedure is as follows:

1. Install Heli-Coil inserts 0.75P to 1.5P below surface with installation tool
2. Remove tangs with tang removal tool

Cleaning Procedure

All test specimen parts are pre-cleaned as follows:

1. Clean all parts (screws, washers, cones and load cell fixtures with installed Heli-Coil inserts) in ultrasonic cleaner with MEK for 3 minutes
2. Replace MEK and repeat step 1
3. Place parts in clean sort box

	NASA Engineering and Safety Center Technical Assessment Report	Document #: NESC-RP-04-092	Version: 1.0
Title: Evaluate the Performance of Loctite® as a Secondary Locking Feature for ISS Fasteners			Page #: 110 of 205

Assembly

Prior to each test, the test screw, washer, cone and load cell fixture with Heli-Coil insert are cleaned again in MEK for 3 minutes and then allowed to dry for 5 minutes.

The assembly procedure for the twelve tests with Loctite 242 threadlocker is as follows:

1. Assemble washer and cone on screw
2. Apply Braycote 601 EF grease under screw head and washer
3. Spray Loctite 7471 activator (Primer T) on screw threads and Heli-Coil threads
4. Let dry for five minutes
5. Apply 2 to 3 drops of Loctite 242 threadlocker to completely cover screw threads and Heli-Coil threads
6. Tighten to specified preload with dial type torque wrench and record preload and maximum tightening torque
7. Allow to cure for 24 hours

The assembly procedure for the twenty-four tests with Braycote 601 EF high vacuum grease is as follows:

1. Assemble washer and cone on screw
2. Apply Braycote 601 EF grease under screw head and washer
3. Apply Braycote 601 EF grease to cover screw threads and Heli-Coil threads
4. Tighten to specified preload with dial type torque wrench and record preload, maximum tightening torque, and prevailing torque

Prior to assembly, the top plate of the test machine is centered. Clean gloves are used for handling the parts. Clean lint-free wipes are placed under parts during drying.

Preliminary Tests

Twenty preliminary tests were performed to determine the test parameters and conditions. It was desired to run these tests at a higher preload and for longer duration than the 1,200 lb preload and 480 cycle duration tests performed in November and December of 2006. In addition, a goal was to identify test parameters that provide significant loosening with the "standard Heli-Coil with Braycote" configuration over a finite number of cycles without causing screws to break for any of the locking levels, so that the performance of the secondary locking features can be compared.

Preliminary tests were performed with preloads of 2,280 and 2,400 lb, duration of 960 and 2,400 cycles, eccentric setting of 3 and 4 mm, and for various washer configurations. The results of these tests are as follows:

1. Tests with the eccentric set at 4 mm resulted in a fastener failure whereas no failures resulted with the eccentric set at 3mm.
2. Tests with cleaned washers without grease resulted in high tightening torque levels and variation that appeared to dictate locking performance.
3. Tests with cleaned washers without grease resulted in notable washer and cone wear (see Appendix B).

	NASA Engineering and Safety Center Technical Assessment Report	Document #: NESC-RP-04-092	Version: 1.0
Title: Evaluate the Performance of Loctite® as a Secondary Locking Feature for ISS Fasteners			Page #: 111 of 205

4. Tests with washers “as received” without cleaning and tests with cleaned washers with grease applied resulted in lower, more repeatable tightening torque and minimal wear (see Appendix B).
5. A test without a washer required a higher tightening torque.
6. A test with an inverted washer showed no difference in tightening torque.
7. Tests with a duration of 2,400 cycles give a better chance of showing a steady-state condition.

Based on these results and the above stated goal, all tests are performed with Braycote grease applied under the screw head and washer, the test machine set at 15Hz with a 0.12 inch (3mm) eccentric, the preload at 2,400 lb or 66% yield, and a record length of 160 seconds or 2,400 cycles. The data was collected at 51.2 samples/second for a total of 8,192 data points for each measured variable for each test.

The preload of 2,400 lb for 66% yield is calculated by multiplying the thread stress area by 66% of the 0.2% yield strength. The thread stress area is 0.0364 in² [10] and the 0.2% yield strength is 100,000 psi.

Experiment Design

The tests in this study are considered single-factor experiments. The secondary locking feature is the single-factor in the experiments. There are three levels of this factor: “Standard Heli-Coil with Braycote”, “Locking Heli-Coil with Braycote”, and “Standard Heli-Coil with Loctite”. The number of replicates used in this study for each level is 12 for a total of 36 runs. Table 1 presents the test run numbers for each level.

The order of the runs is randomized according to the test sequence shown in Table 2. The test sequence is randomized using the Excel “rand” function and sort tool. A column of random numbers is generated for the column of thirty-six run numbers. The two columns are sorted such that the random numbers are in ascending order. The resulting order of the run numbers is random and defines the test sequence as listed in Table 2.

The response variable used in this study is the “percent loss of preload” defined by $100(P_i - P_r) / P_i$ where P_i is the initial preload and P_r is the residual preload after n cycles. Based on observations from the preliminary tests, the “percent loss of preload” is computed after 2,300 cycles. The initial and residual preloads are extracted from the measured preload time trace of 2,400 cycles obtained for each run.

Test Data

Representative preload versus cycles plots are shown in Figures 4 through 6 for all three locking levels. This data for all thirty-six runs is provided in Appendix C. For these tests, the dynamic shear force varies from an initial range of ±210 lb to ±10 lb for a completely loose screw. The transverse displacement varies from an initial range of ±0.03 inch to ±0.05 inch for a completely loose screw.



NASA Engineering and Safety Center Technical Assessment Report

Document #:
**NESC-RP-
04-092**

Version:
1.0

Title:

Evaluate the Performance of Loctite® as a Secondary Locking Feature for ISS Fasteners

Page #:
112 of 205

Table 1 Experiment run numbers for three locking levels

Locking Level	Experiment Run Number											
Std Heli-Coil w/ Braycote	1	2	3	4	5	6	7	8	9	10	11	12
Locking Heli-Coil w/ Braycote	13	14	15	16	17	18	19	20	21	22	23	24
Std Heli-Coil w/ Loctite	25	26	27	28	29	30	31	32	33	34	35	36

Table 2 Randomized test sequence

Test Sequence	Run Number	Locking Level
1	7	Std Heli-Coil w/ Braycote
2	13	Locking Heli-Coil w/ Braycote
3	1	Std Heli-Coil w/ Braycote
4	10	Std Heli-Coil w/ Braycote
5	30	Std Heli-Coil w/ Loctite
6	27	Std Heli-Coil w/ Loctite
7	6	Std Heli-Coil w/ Braycote
8	3	Std Heli-Coil w/ Braycote
9	16	Locking Heli-Coil w/ Braycote
10	22	Locking Heli-Coil w/ Braycote
11	5	Std Heli-Coil w/ Braycote
12	28	Std Heli-Coil w/ Loctite
13	26	Std Heli-Coil w/ Loctite
14	21	Locking Heli-Coil w/ Braycote
15	12	Std Heli-Coil w/ Braycote
16	14	Locking Heli-Coil w/ Braycote
17	31	Std Heli-Coil w/ Loctite
18	24	Locking Heli-Coil w/ Braycote
19	29	Std Heli-Coil w/ Loctite
20	36	Std Heli-Coil w/ Loctite
21	2	Std Heli-Coil w/ Braycote
22	34	Std Heli-Coil w/ Loctite
23	25	Std Heli-Coil w/ Loctite
24	19	Locking Heli-Coil w/ Braycote
25	4	Std Heli-Coil w/ Braycote
26	8	Std Heli-Coil w/ Braycote
27	23	Locking Heli-Coil w/ Braycote
28	9	Std Heli-Coil w/ Braycote
29	32	Std Heli-Coil w/ Loctite
30	17	Locking Heli-Coil w/ Braycote
31	33	Std Heli-Coil w/ Loctite
32	15	Locking Heli-Coil w/ Braycote
33	11	Std Heli-Coil w/ Braycote
34	35	Std Heli-Coil w/ Loctite
35	18	Locking Heli-Coil w/ Braycote
36	20	Locking Heli-Coil w/ Braycote



Title:

**Evaluate the Performance of Loctite® as a Secondary
Locking Feature for ISS Fasteners**

Page #:
113 of 205

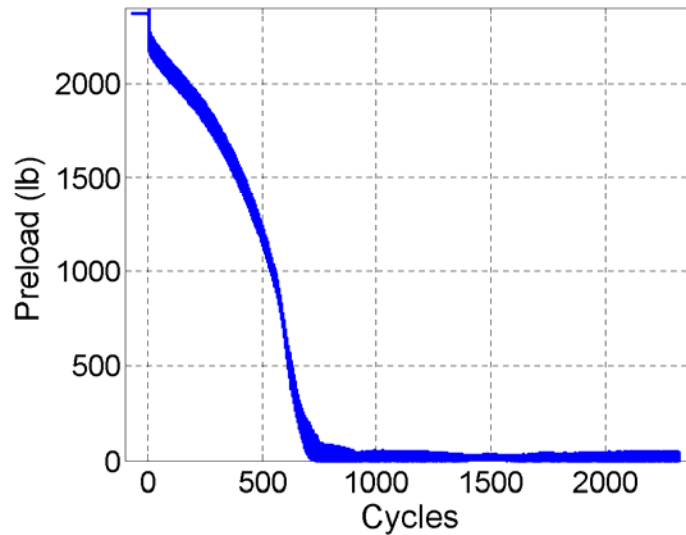

Figure 4 Preload versus cycles for "Standard Heli-Coil with Braycote" run number 8.

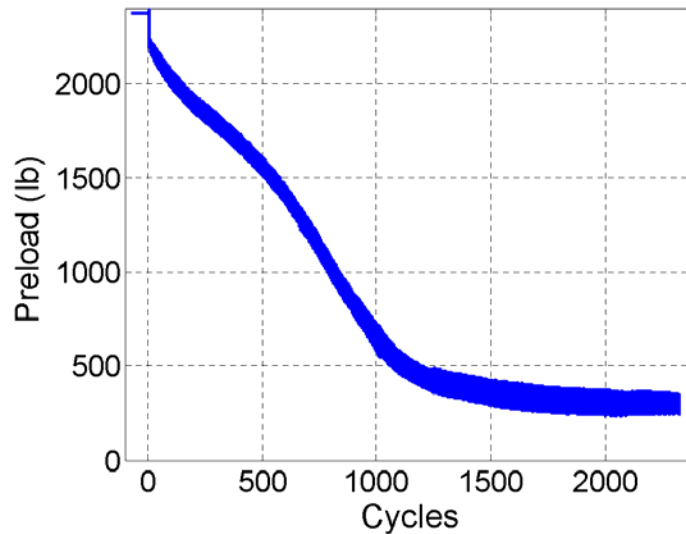

Figure 5 Preload versus cycles for "Locking Heli-Coil with Braycote" run number 15.



NASA Engineering and Safety Center Technical Assessment Report

Document #:
**NESC-RP-
04-092**

Version:
1.0

Title:

Evaluate the Performance of Loctite® as a Secondary Locking Feature for ISS Fasteners

Page #:
114 of 205

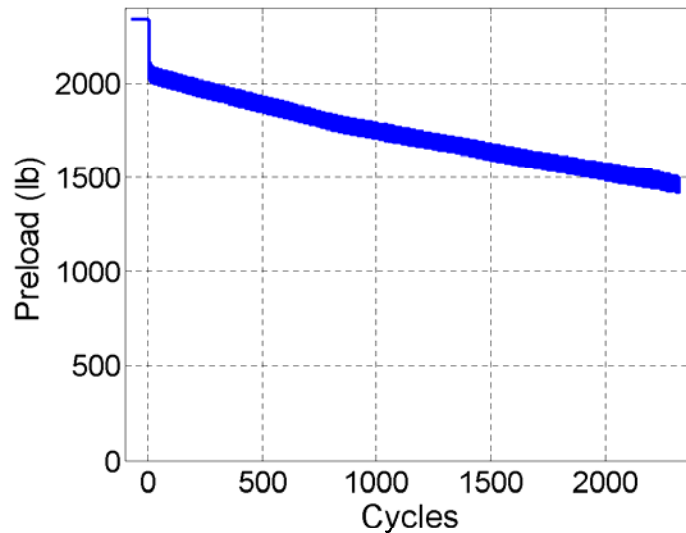

Figure 6 Preload versus cycles for “Standard Heli-Coil with Loctite” run number 28.

A composite plot of all twelve of the “Standard Heli-Coil with Braycote” runs is presented in Figure 7. Only the minimum preload values per cycle are plotted. Composite plots for the “Locking Heli-Coil with Braycote” and the “Standard Heli-Coil with Loctite” data are presented in Figure 8 and 9, respectively. These composite plots show the variation in the twelve runs for each locking level. This data reveals that, on average, the “Standard Heli-Coil with Braycote” has the poorest locking performance and the “Standard Heli-Coil with Loctite” has the best locking performance.

All of the preload versus cycle plots show a notable drop in preload at the onset of testing, i.e., near zero cycles. This may be due to the release of twist or torsional energy built up in the screw during tightening.

For one of the runs with Loctite, run 29, the screw broke at 2,324 cycles. The corresponding preload versus cycle curve (see Figures C29 and 9) for this run illustrates this rapid failure. This suggests that the tests operate close to the lower bound of the screw fatigue life when the majority of the preload is maintained for close to the duration of the test.



Title:

Evaluate the Performance of Loctite® as a Secondary
Locking Feature for ISS Fasteners

Page #:
115 of 205

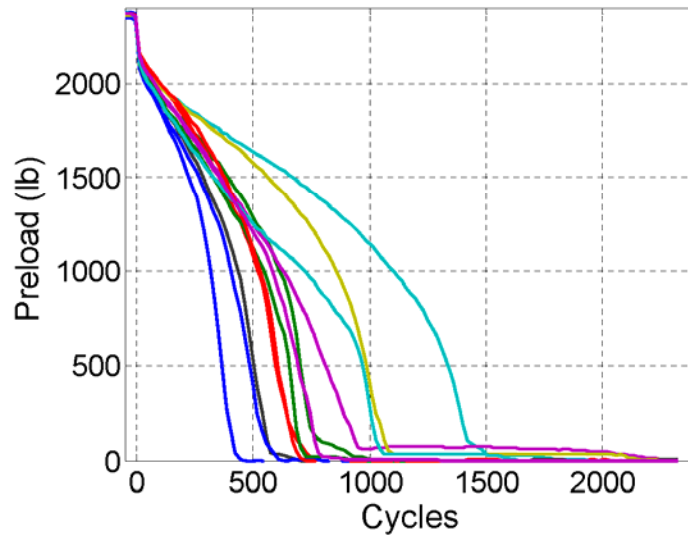

Figure 7 Composite plot for "Standard Heli-Coil with Braycote" runs.

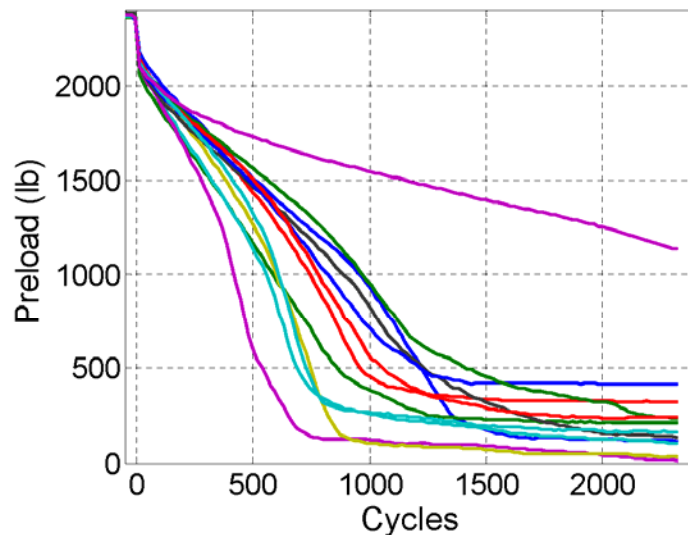

Figure 8 Composite plot for "Locking Heli-Coil with Braycote" runs.



NASA Engineering and Safety Center Technical Assessment Report

Document #:
**NESC-RP-
04-092**

Version:
1.0

Title:

Evaluate the Performance of Loctite® as a Secondary Locking Feature for ISS Fasteners

Page #:
116 of 205

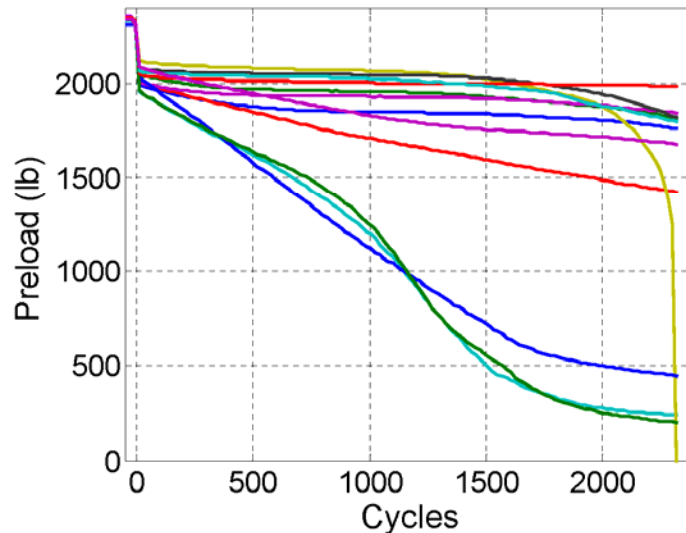

Figure 9 Composite plot for "Standard Heli-Coil with Loctite" runs.

The initial and residual preloads are extracted from the preload measurements for all thirty-six runs. Table 3 lists the initial preload, the residual preloads after 2,300 cycles, and the computed percent loss of preload after 2,300 cycles. The initial preload varies from 2,315 to 2,385 lb due to joint embedment and assembly variation. The data reveals that the "Standard Heli-Coil with Loctite" runs 25 to 36 have lower initial preload than the other runs due to the 24 hour cure time period between tightening and testing. The time period between tightening and testing for the other runs is about one minute.

The maximum tightening torque, assembly prevailing torque, and removal prevailing torque for each run are presented in Table 4. The data shows that the tightening torque to achieve the nominal 2,400 lb preload for "Standard Heli-Coil with Braycote" (runs 1 to 12) ranges from 100 to 105 in-lbs. The increase in required tightening torque for "Locking Heli-Coil with Braycote" results from the assembly prevailing torque of 20 in-lbs. The higher required tightening torque for the "Standard Heli-Coil with Loctite" is due to higher friction with Loctite threadlocker than with Braycote grease.

The removal prevailing torque for the "Locking Heli-Coil with Braycote" and "Standard Heli-Coil with Loctite" runs are found to be comparable. The removal prevailing torque for the "Locking Heli-Coil with Braycote" runs is lower than the assembly prevailing torque due to wear from assembly and testing.



**NASA Engineering and Safety Center
Technical Assessment Report**

Document #:
**NESC-RP-
04-092**

Version:
1.0

Title:

**Evaluate the Performance of Loctite® as a Secondary
Locking Feature for ISS Fasteners**

Page #:
117 of 205

Table 3 Preload test data

Run number	Initial preload (lbs)	Residual preload after 2,300 cycles (lbs)	% loss preload after 2,300 cycles
1	2365	0	100
2	2375	0	100
3	2375	0	100
4	2370	0	100
5	2360	0	100
6	2360	0	100
7	2350	0	100
8	2365	0	100
9	2370	0	100
10	2365	0	100
11	2370	0	100
12	2370	0	100
13	2370	120	95
14	2375	15	99
15	2375	250	89
16	2360	220	91
17	2370	240	90
18	2370	165	93
19	2385	140	94
20	2370	1145	52
21	2365	110	95
22	2380	325	86
23	2365	415	82
24	2365	35	99
25	2350	205	91
26	2330	245	89
27	2345	1825	22
28	2335	1430	39
29	2345	1320	44
30	2315	1765	24
31	2355	1845	22
32	2345	1985	15
33	2340	1805	23
34	2340	455	81
35	2340	1680	28
36	2340	1830	22



NASA Engineering and Safety Center Technical Assessment Report

Document #:
**NESC-RP-
04-092**

Version:
1.0

Title:

Evaluate the Performance of Loctite® as a Secondary Locking Feature for ISS Fasteners

Page #:
118 of 205

Table 4 Torque test data

Run number	Maximum tightening torque (in-lbs)	Assembly prevailing torque (in-lbs)	Removal prevailing torque (in-lbs)
1	100	-	-
2	100	-	-
3	100	-	-
4	100	-	-
5	100	-	-
6	105	-	-
7	100	-	-
8	100	-	-
9	100	-	-
10	105	-	-
11	100	-	-
12	105	-	-
13	120	20	15
14	120	20	10
15	115	20	15
16	120	20	15
17	125	20	15
18	115	20	15
19	120	20	15
20	115	20	15
21	120	20	10
22	120	20	15
23	115	20	15
24	120	20	15
25	115	-	10
26	110	-	15
27	115	-	20
28	115	-	20
29	115	-	.*
30	110	-	20
31	115	-	20
32	110	-	20
33	110	-	20
34	110	-	15
35	115	-	20
36	110	-	15

*The screw broke at 2,324 cycles in run 29

Statistical Analyses

The resulting response data (percent loss of preload data) from the 36 tests are presented again in Table 5 for 2,300 cycles. There are twelve observations for each locking level. The basic statistics of mean and variance for each sample are included.



NASA Engineering and Safety Center Technical Assessment Report

Document #:
NESC-RP-04-092

Version:
1.0

Title:

Evaluate the Performance of Loctite® as a Secondary Locking Feature for ISS Fasteners

Page #:
119 of 205

Table 5 Percent loss of preload after 2,300 cycles

Locking Level	Observations												Sample Mean	Sample Variance	
	1	2	3	4	5	6	7	8	9	10	11	12			
Std Heli-Coil w/ Braycote	100	100	100	100	100	100	100	100	100	100	100	100	100	100	0
Locking Heli-Coil w/ Braycote	95	99	89	91	90	93	94	52	95	86	82	99	88.8	159	
Std Heli-Coil w/ Loctite	91	89	22	39	44	24	22	15	23	81	28	22	41.7	814	

The “Standard Heli-Coil with Braycote” observations at 2,300 cycles are all equal and indicate that 100 percent loss of preload occurs by 2,300 cycles. The variance for this sample of observations is zero. As expected, the other two locking levels show less loss of preload at 2,300 cycles.

The “percent loss of preload” data after 2,300 cycles for the “Locking Heli-Coil with Braycote” and the “Standard Heli-Coil with Loctite” levels are presented in box plots in Figure 10. The blue and red horizontal lines are at the lower quartile, median and upper quartile values of each sample. The black whiskers extend to indicate the extent of each sample. The “Standard Heli-Coil with Braycote” samples are not included in the box plots since there is no variation in these samples and there is 100 percent loss of preload for all observations at this level.

This analysis is extended to the preload versus cycle data from Figures 7 through 9. The corresponding computed mean, median, upper and lower quartiles, and extents for the three levels are presented in Figures 11 through 13. The mean is the green curve, the median is the red, the quartiles are blue, and the extents are the black dashed lines.

The test machine settings and parameters in this study were selected to cause loosening and provide a comparison of performance of secondary locking features. The data and analysis show that:

1. “Locking Heli-Coil with Braycote”, on average, provides better resistance to loosening than “Standard Heli-Coil with Braycote”, and
2. “Standard Heli-Coil with Loctite”, on average, has better locking performance than “Locking Heli-Coil with Braycote”.

Conclusions

In this study, a series of tests were performed to provide a comparative assessment of the locking performance (or loosening resistance) of NAS1004 ¼-28 UNJF-3A hex head screws with:

1. Standard free-running Heli-Coil inserts with Braycote 601 EF high vacuum grease
2. Locking Heli-Coil inserts with Braycote 601 EF high vacuum grease, and
3. Standard free-running Heli-Coil inserts with Loctite 242 threadlocker.



NASA Engineering and Safety Center Technical Assessment Report

Document #:
**NESC-RP-
04-092**

Version:
1.0

Title:

Evaluate the Performance of Loctite® as a Secondary Locking Feature for ISS Fasteners

Page #:
120 of 205

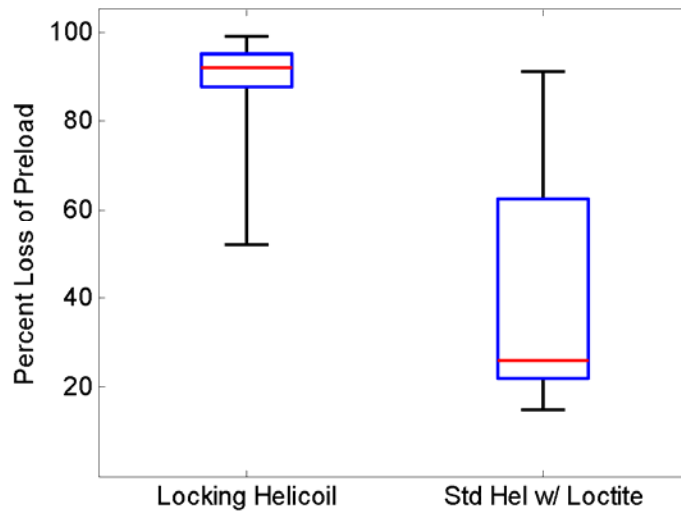

Figure 10 Box plots of percent loss of preload after 2,300 cycles.

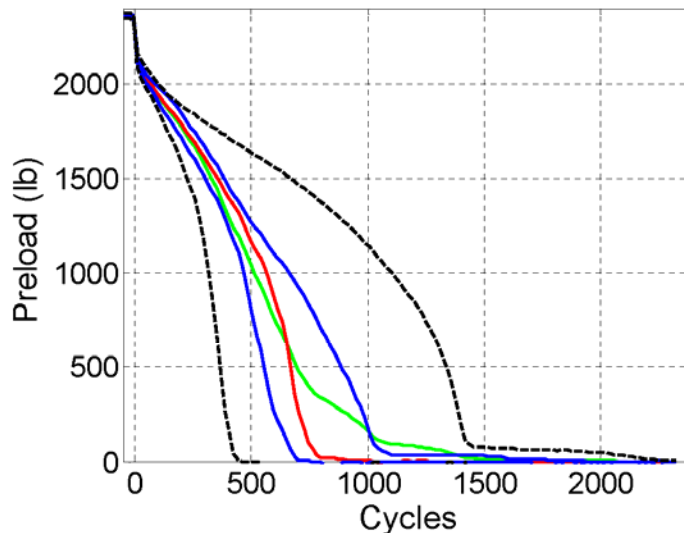

Figure 11 Mean, median, upper and lower quartile, and extent curves for "Standard Heli-Coil with Braycote" runs.



Title:

**Evaluate the Performance of Loctite® as a Secondary
Locking Feature for ISS Fasteners**

Page #:
121 of 205

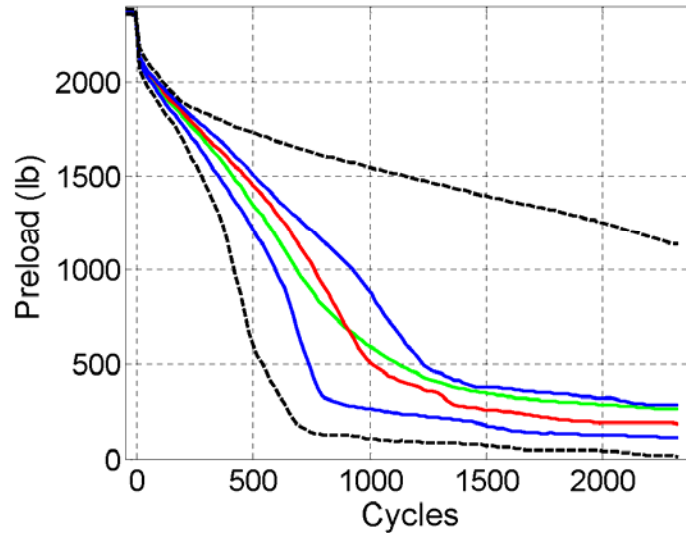

Figure 12 Mean, median, upper and lower quartile, and extent curves for “Locking Heli-Coil with Braycote” runs.

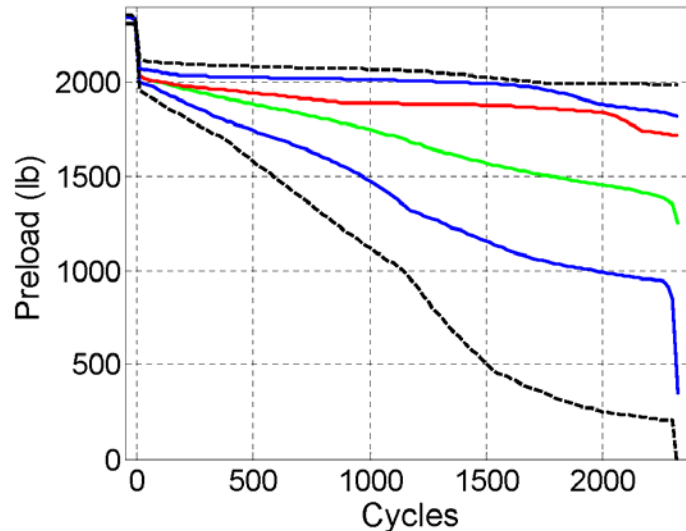



Figure 13 Mean, median, upper and lower quartile, and extent curves for “Standard Heli-Coil with Loctite” runs.

	NASA Engineering and Safety Center Technical Assessment Report	Document #: NESC-RP-04-092	Version: 1.0
Title: Evaluate the Performance of Loctite® as a Secondary Locking Feature for ISS Fasteners		Page #: 122 of 205	

The tests were performed on a DIN 65151 or Junker type test machine which provides dynamic shear loading. Twelve tests were performed for each locking level. The test machine parameters were selected to provide significant loosening with the "Standard Heli-Coil with Braycote" configuration over a finite number of cycles without causing screws to break for any of the locking levels, so that the performance of the secondary locking features can be compared. The tests were performed with the test machine at 15Hz with a 0.12 inch (3mm) eccentric, preload at 66% yield or 2,400 lb, and a record length of 2,400 cycles.

Preload versus cycles data were collected and presented for each run. The percent loss of preload was determined after 2,300 cycles for each test run. The data and analyses presented show the "Standard Heli-Coil with Loctite 242 threadlocker", on average, provides better locking performance than the "Locking Heli-Coil with Braycote 601 EF grease". The "Standard Heli-Coil with Braycote 601 EF grease", on average, has the worse locking performance of the three levels.

References

1. Junker, G.H., 1969, "New Criteria for Self-Loosening of Fasteners Under Vibration," *SAE Transactions*, Vol. 78, pp. 314-335.
2. DIN 65151, 2002, Aerospace Series – Dynamic Testing of the Locking Characteristics of Fasteners Under Transverse Loading Conditions (Vibration Test), Deutsches Institut Fur Normung E.V. (German National Standard).
3. Pai, N.P. and Hess, D.P., 2002, "Experimental Study of Loosening of Threaded Fasteners Due to Dynamic Shear Load," *Journal of Sound and Vibration*, Vol. 253, pp. 585-692.
4. Sanclemente, J.A. and Hess, D.P., 2007, "Parametric Study of Threaded Fastener Loosening Due to Cyclic Transverse Load," *Engineering Failure Analysis*, Vol. 14, pp. 239-249.
5. Elliot, K., 2006-07, NASA Langley Research Center, private correspondence.
6. MIL-STD-1312-7A, 1984, Fastener Test Methods - Method 7: Vibration, U.S. Department of Defense, Washington D.C.
7. NAS 1003 thru 1020, 1991, National Aerospace Standard, pp. 1-3.
8. NAS 1149, 1994, National Aerospace Standard, pp. 1-6.
9. Emhart Technologies Heli-Coil Bulletin, 2003, www.emhart.com
10. Bickford, J.H., 1995, *An Introduction to the Design and Behavior of Bolted Joints*, 3rd ed., Marcel Dekker.

	NASA Engineering and Safety Center Technical Assessment Report	Document #: NESC-RP-04-092	Version: 1.0
Title: Evaluate the Performance of Loctite® as a Secondary Locking Feature for ISS Fasteners			Page #: 123 of 205

Appendix A: Information on Product Used in Tests

1. Hex head screws:
 - a. Part # NAS1004-29A
 - b. Manufacturer: California Screw Products Corp., Paramount, CA
 - c. Lot # 26306
 - d. Seller: HC Pacific, Walnut, CA
 - e. Thread: ¼-28 UNJF-3A, Length: 2.356 inch, Material: A286 stainless steel

2. Washers:
 - a. Part # NAS1149C0463R
 - b. Manufacturer: Superior Washer & Gasket Corp., Hauppauge, NY
 - c. Lot # 65603 / 391629-0
 - d. Seller: Genuine Aircraft Hardware Co., Paso Robles, CA
 - e. Material: corrosion resistant steel with a passivated finish

3. Free-running Heli-Coil inserts:
 - a. Part # 1191-4CN375 (MS124696)
 - b. Manufacturer: Emhart Teknologies, Danbury, CT
 - c. Control #: 366792-1
 - d. Seller: MSC, Melville, NY
 - e. Size: ¼-28, Length: 0.375 inch, Material: 304 stainless steel

4. Screw-lock Heli-Coil inserts:
 - a. Part # 3591-4CN375 (MS21209-F4-15)
 - b. Manufacturer: Emhart Teknologies, Danbury, CT
 - c. Control #: 399893-1
 - d. Seller: MSC, Melville, NY
 - e. Size: ¼-28, Length: 0.375 inch, Material: 304 stainless steel

5. Braycote 601 EF Grease
 - a. Manufacturer: Castrol, Naperville, IL
 - b. Lot #: 98497
 - c. Seller: SPI Supplies, West Chester, PA

6. Loctite 242 Threadlocker
 - a. Manufacturer: Henkel Loctite Corp, Rocky Hill, CT
 - b. Control #: L37AAA6503
 - c. Seller: MSC, Melville, NY

7. Loctite 7471 Activator / Primer
 - a. Manufacturer: Henkel Loctite Corp, Rocky Hill, CT
 - b. Control #: 22477
 - c. Seller: MSC, Melville, NY

	NASA Engineering and Safety Center Technical Assessment Report	Document #: NESC-RP-04-092	Version: 1.0
Title: Evaluate the Performance of Loctite® as a Secondary Locking Feature for ISS Fasteners			Page #: 124 of 205

Appendix B: Washer Wear

Preliminary tests with cleaned washers without grease resulted in high, unrepeatable tightening torques and notable wear on washers and cones, whereas tests with washers “as received” without cleaning and tests with cleaned washers with grease applied resulted in lower, more repeatable tightening torque and minimal wear. This appendix presents photographs of representative washers and cones.

Photographs of the top or screw head side of five representative washers from tests with initial preload of 2,280 lb are shown in Figures B1 through B5. A rough wear ring likely from galling resulted from using cleaned washers without grease (see Figures B2 and B3). A minor circular mark from screw heads pressing into washers resulted from using washers “as received” without cleaning or cleaned washers with grease applied (see Figures B4 and B5).

Photographs of both sides of a representative cleaned washer with grease applied and mating cone face from a test with initial preload of 2,400 lb are shown in Figures B6 through B8. A minor circular mark from a screw head pressing into the washer is shown in Figure B6. Minor circular marks from finish marks on the mating cone pressing into the washer are shown in Figure B7.

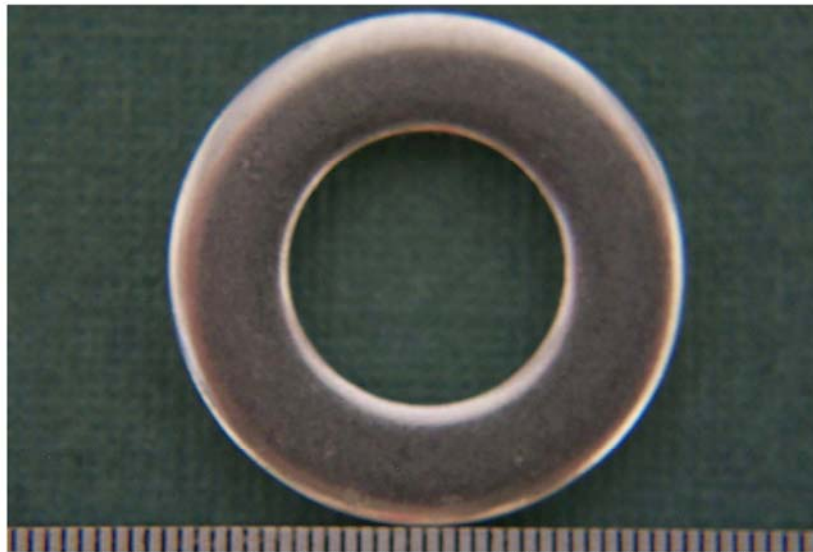

Figure B1 Top side of a new unused washer (scale marks are 1/64 inch).



NASA Engineering and Safety Center Technical Assessment Report

Document #:
**NESC-RP-
04-092**

Version:
1.0

Title:

Evaluate the Performance of Loctite® as a Secondary Locking Feature for ISS Fasteners

Page #:
125 of 205

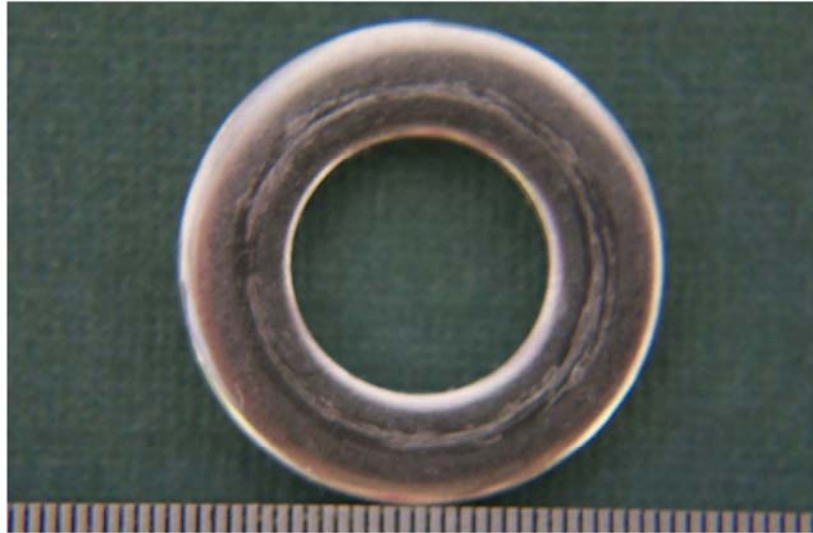

Figure B2 Top side of a washer used clean without grease.

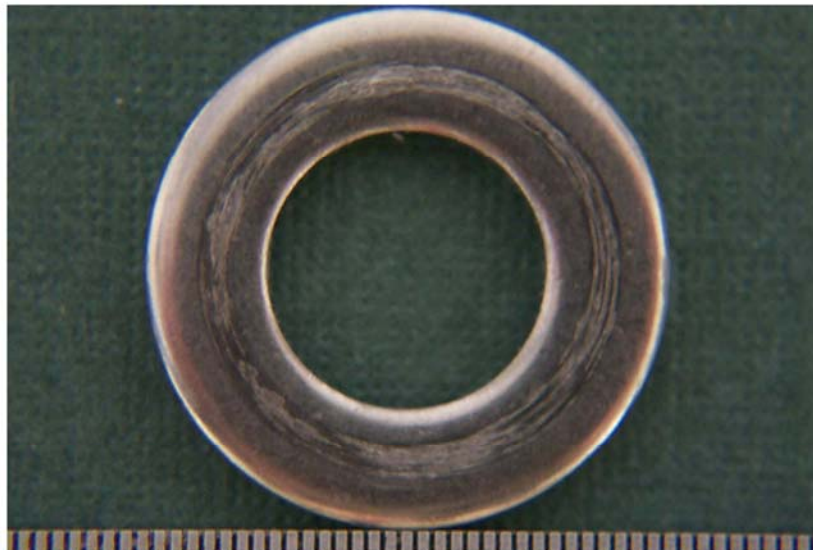

Figure B3 Top side of a washer reused clean without grease.



NASA Engineering and Safety Center Technical Assessment Report

Document #:
**NESC-RP-
04-092**

Version:
1.0

Title:

Evaluate the Performance of Loctite® as a Secondary Locking Feature for ISS Fasteners

Page #:
126 of 205



Figure B4 Top side of a washer used "as received" without cleaning.

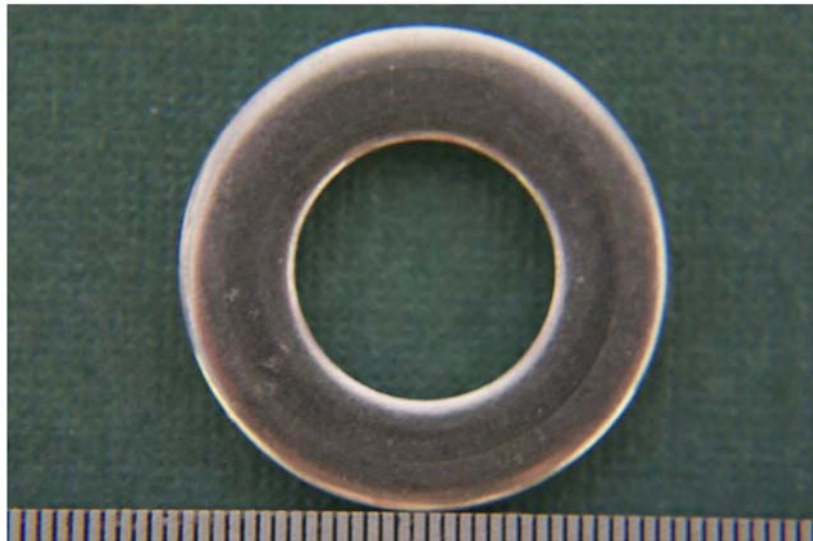

Figure B5 Top side of a washer used with Braycote grease and 2,280lb preload.



**NASA Engineering and Safety Center
Technical Assessment Report**

Document #:
**NESC-RP-
04-092**

Version:
1.0

Title:

**Evaluate the Performance of Loctite® as a Secondary
Locking Feature for ISS Fasteners**

Page #:
127 of 205

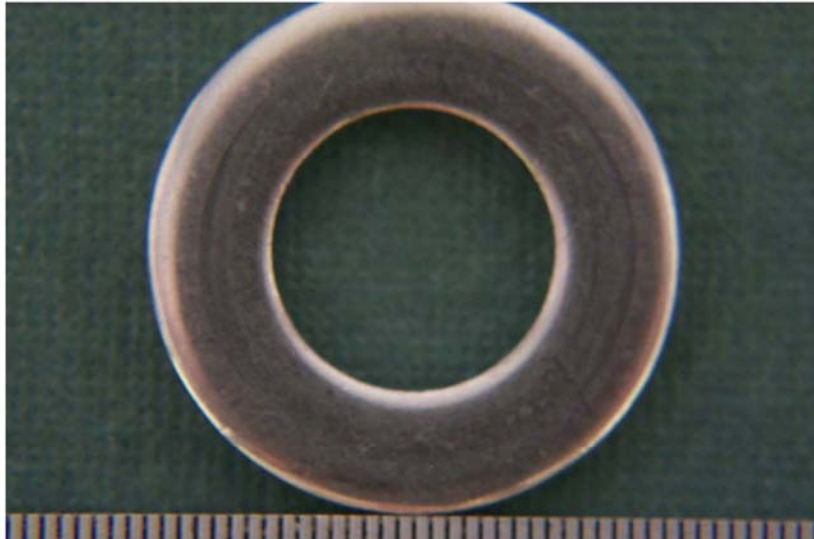

Figure B6 Top side of a washer used with Braycote grease and 2,400 lb preload.

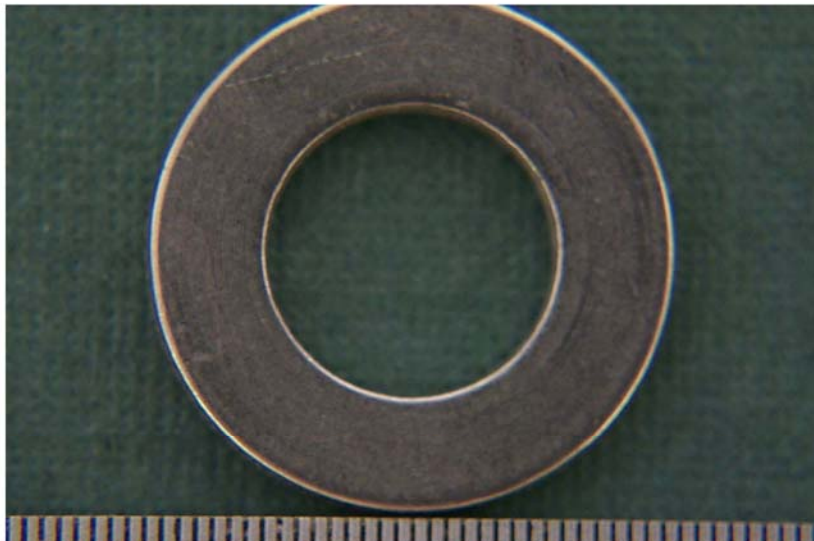



Figure B7 Bottom side of a washer used with Braycote grease.

	<p align="center">NASA Engineering and Safety Center Technical Assessment Report</p>	<p>Document #: NESC-RP-04-092</p>	<p>Version: 1.0</p>
<p>Title: Evaluate the Performance of Loctite® as a Secondary Locking Feature for ISS Fasteners</p>			<p>Page #: 128 of 205</p>

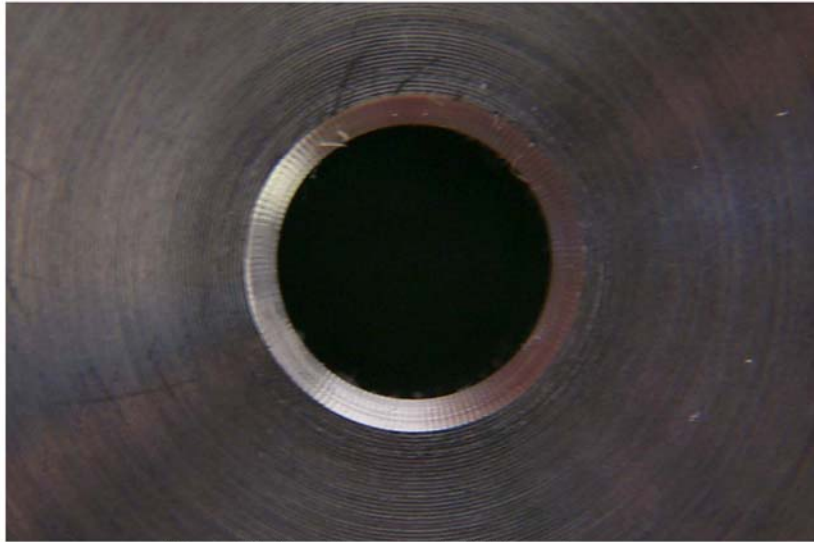

Figure B8 Top of cone used with Braycote grease.



NASA Engineering and Safety Center Technical Assessment Report

Document #:
**NESC-RP-
04-092**

Version:
1.0

Title:

Evaluate the Performance of Loctite® as a Secondary Locking Feature for ISS Fasteners

Page #:
129 of 205

Appendix C: Preload versus Cycles Data

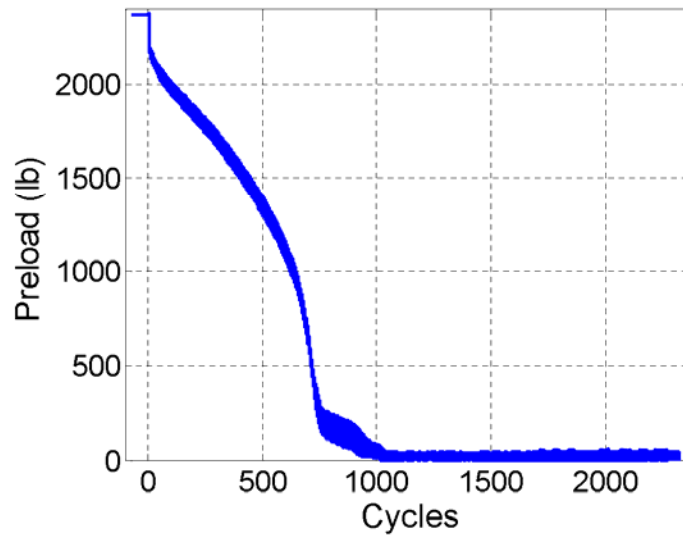

Figure C1 Preload versus cycles for "Standard Heli-Coil with Braycote" run number 1.

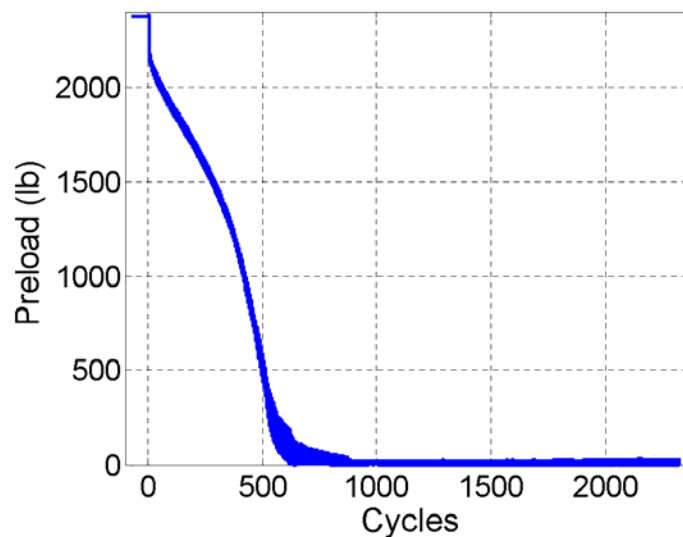

Figure C2 Preload versus cycles for "Standard Heli-Coil with Braycote" run number 2.



Title:

**Evaluate the Performance of Loctite® as a Secondary
Locking Feature for ISS Fasteners**

Page #:
130 of 205

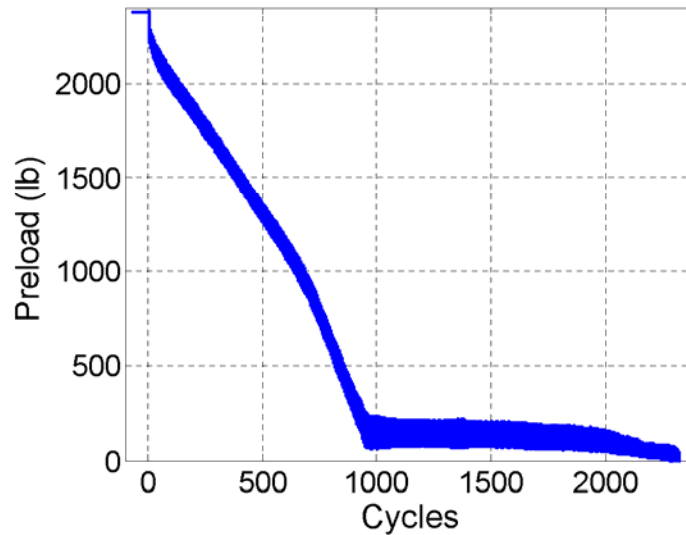

Figure C3 Preload versus cycles for "Standard Heli-Coil with Braycote" run number 3.

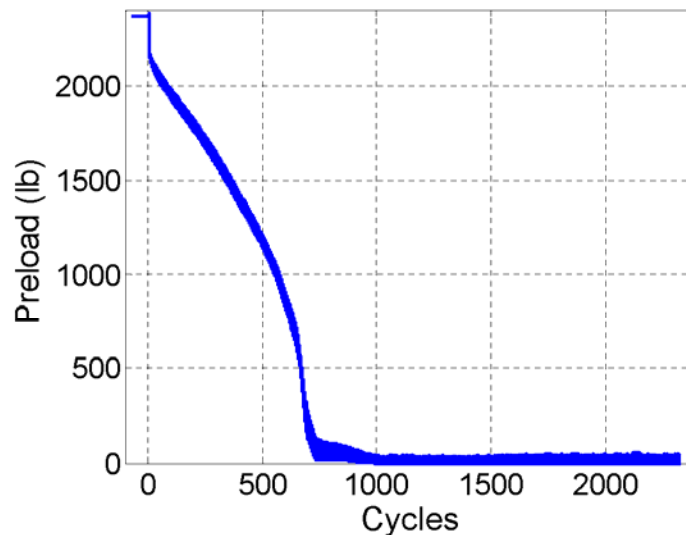

Figure C4 Preload versus cycles for "Standard Heli-Coil with Braycote" run number 4.



Title:

**Evaluate the Performance of Loctite® as a Secondary
Locking Feature for ISS Fasteners**

Page #:
131 of 205

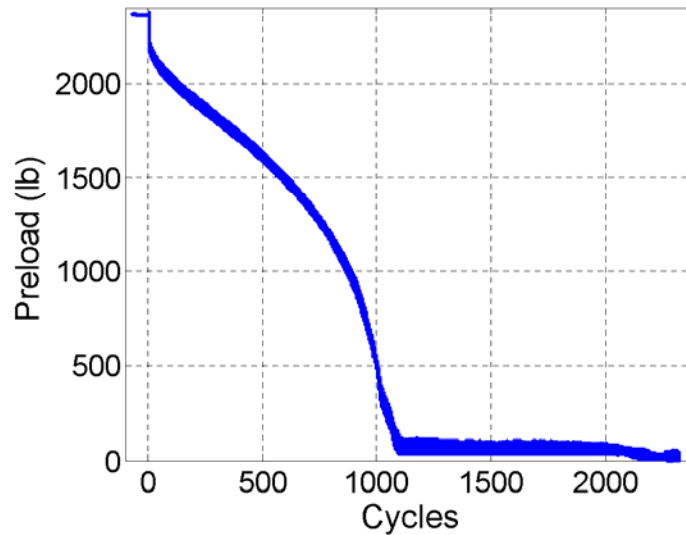

Figure C5 Preload versus cycles for "Standard Heli-Coil with Braycote" run number 5.

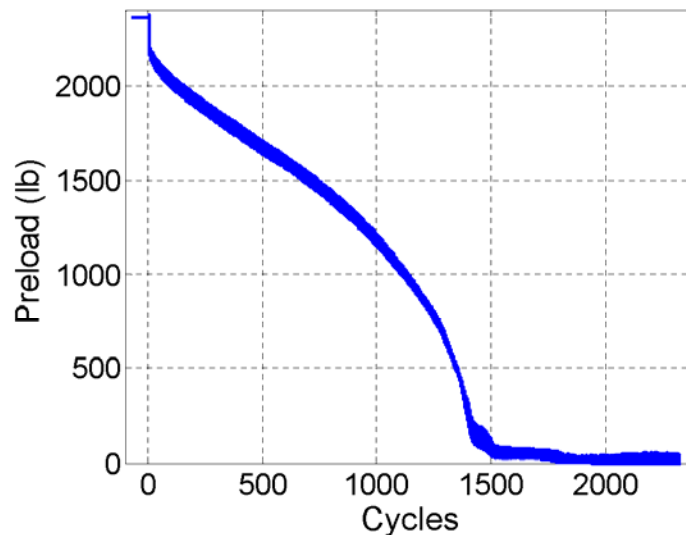

Figure C6 Preload versus cycles for "Standard Heli-Coil with Braycote" run number 6.



NASA Engineering and Safety Center Technical Assessment Report

Document #:
**NESC-RP-
04-092**

Version:
1.0

Title:

Evaluate the Performance of Loctite® as a Secondary Locking Feature for ISS Fasteners

Page #:
132 of 205

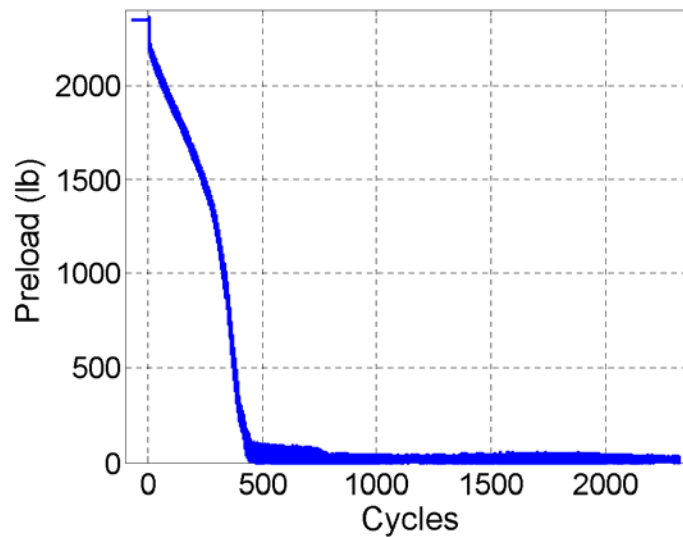

Figure C7 Preload versus cycles for "Standard Heli-Coil with Braycote" run number 7.

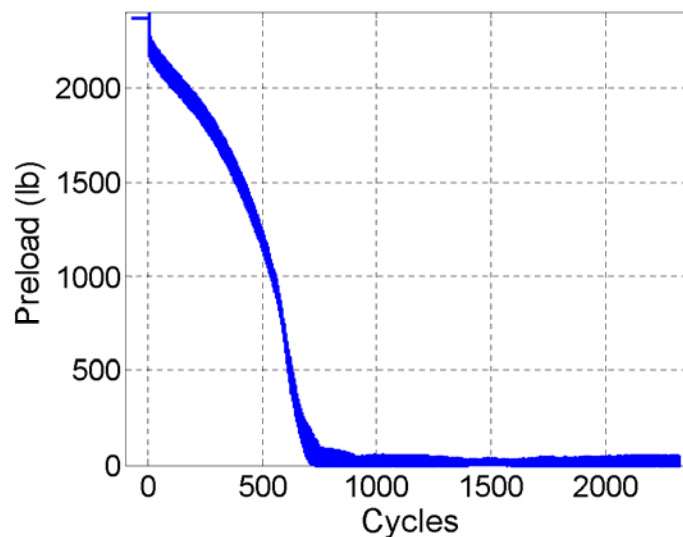

Figure C8 Preload versus cycles for "Standard Heli-Coil with Braycote" run number 8.



Title:

**Evaluate the Performance of Loctite® as a Secondary
Locking Feature for ISS Fasteners**

Page #:
133 of 205

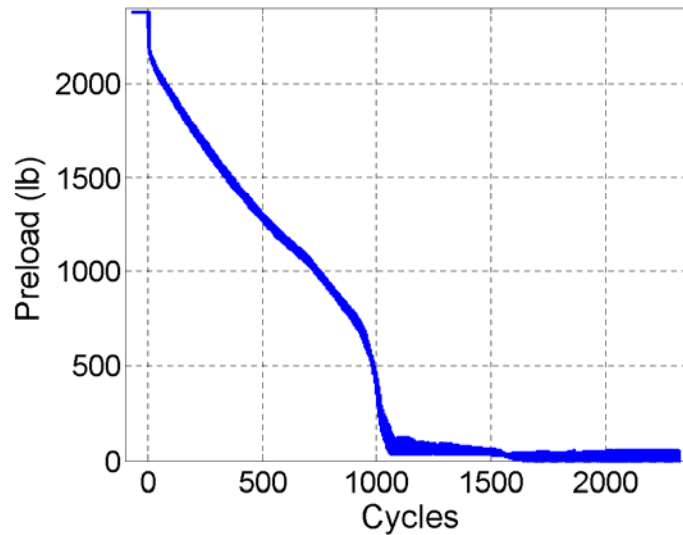

Figure C9 Preload versus cycles for "Standard Heli-Coil with Braycote" run number 9.

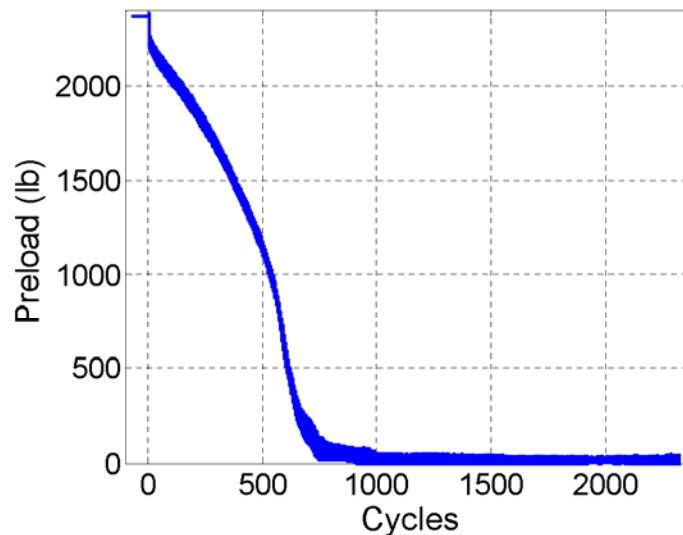

Figure C10 Preload versus cycles for "Standard Heli-Coil with Braycote" run number 10.



NASA Engineering and Safety Center Technical Assessment Report

Document #:
**NESC-RP-
04-092**

Version:
1.0

Title:

Evaluate the Performance of Loctite® as a Secondary Locking Feature for ISS Fasteners

Page #:
134 of 205

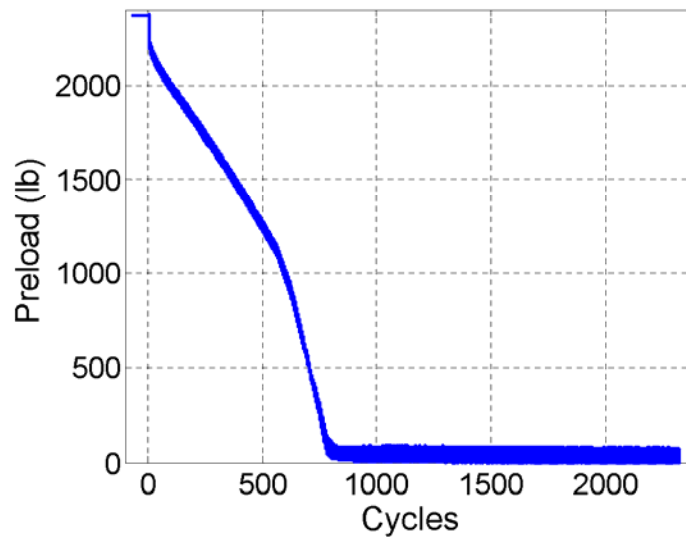

Figure C11 Preload versus cycles for "Standard Heli-Coil with Braycote" run number 11.

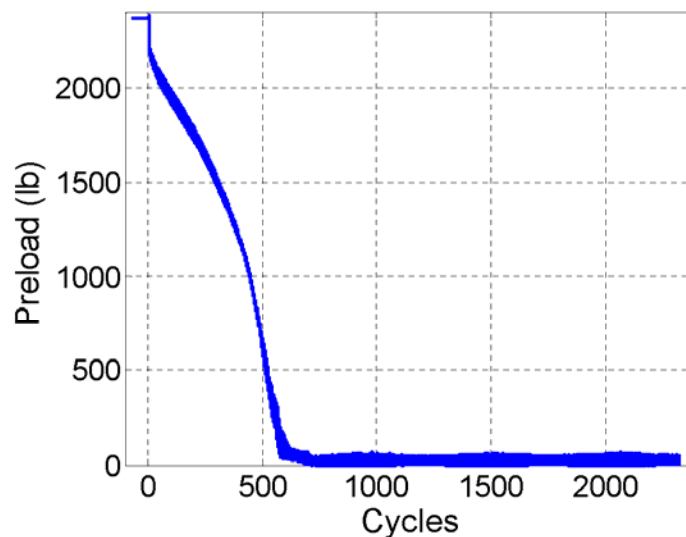

Figure C12 Preload versus cycles for "Standard Heli-Coil with Braycote" run number 12.



Title:

**Evaluate the Performance of Loctite® as a Secondary
Locking Feature for ISS Fasteners**

Page #:
135 of 205

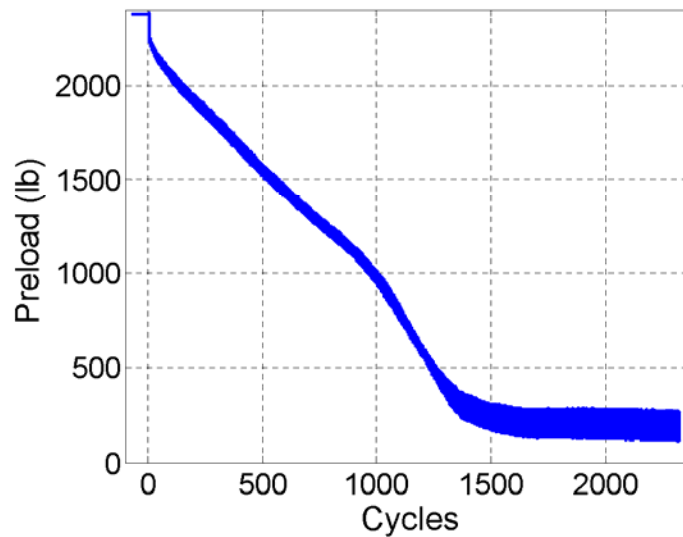

Figure C13 Preload versus cycles for "Locking Heli-Coil with Braycote" run number 13.

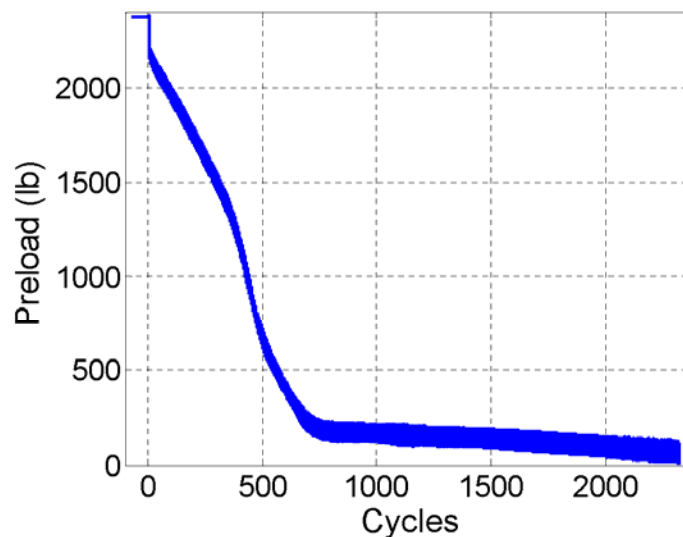

Figure C14 Preload versus cycles for "Locking Heli-Coil with Braycote" run number 14.



Title:

**Evaluate the Performance of Loctite® as a Secondary
Locking Feature for ISS Fasteners**

Page #:
136 of 205

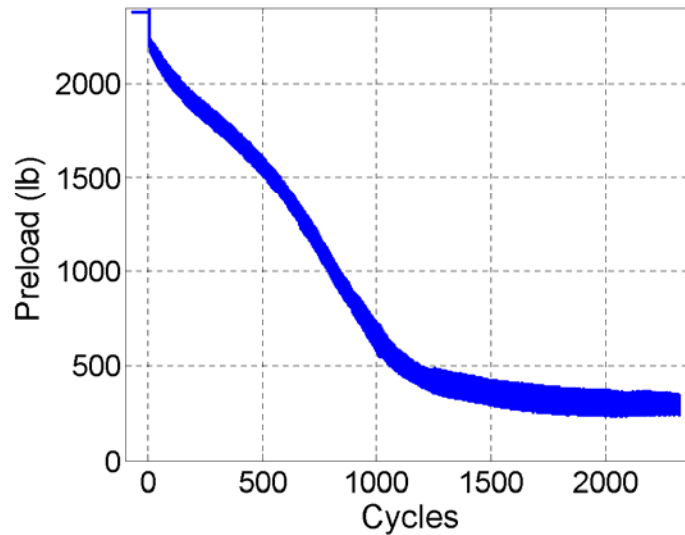

Figure C15 Preload versus cycles for "Locking Heli-Coil with Braycote" run number 15.

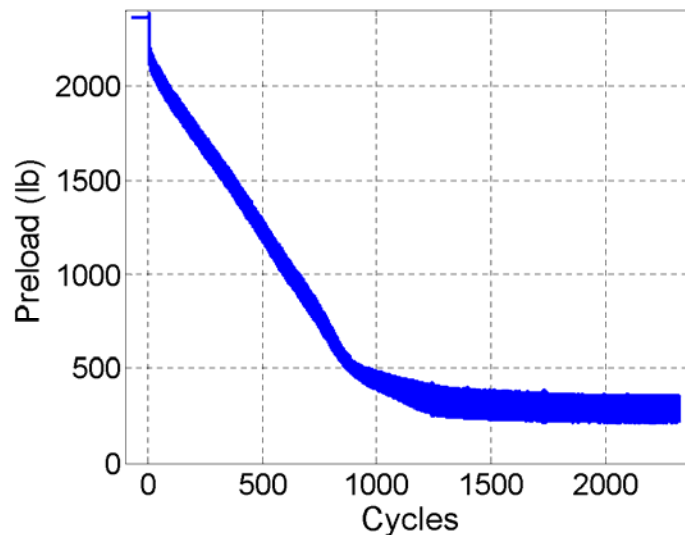

Figure C16 Preload versus cycles for "Locking Heli-Coil with Braycote" run number 16.



NASA Engineering and Safety Center Technical Assessment Report

Document #:
**NESC-RP-
04-092**

Version:
1.0

Title:

Evaluate the Performance of Loctite® as a Secondary Locking Feature for ISS Fasteners

Page #:
137 of 205

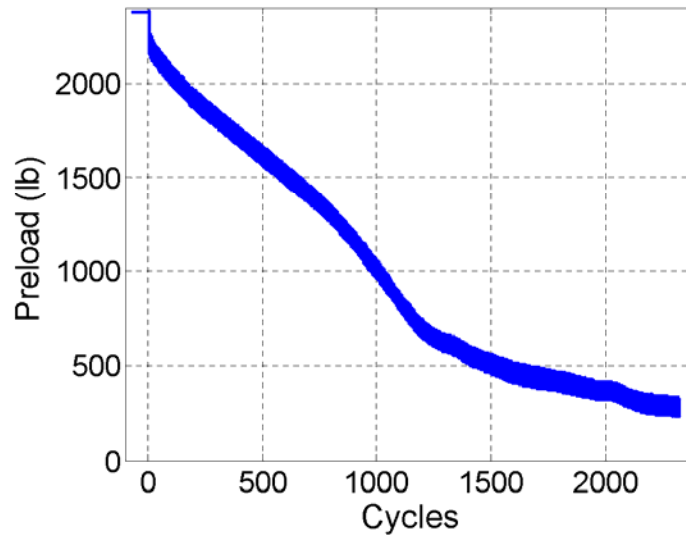

Figure C17 Preload versus cycles for "Locking Heli-Coil with Braycote" run number 17.

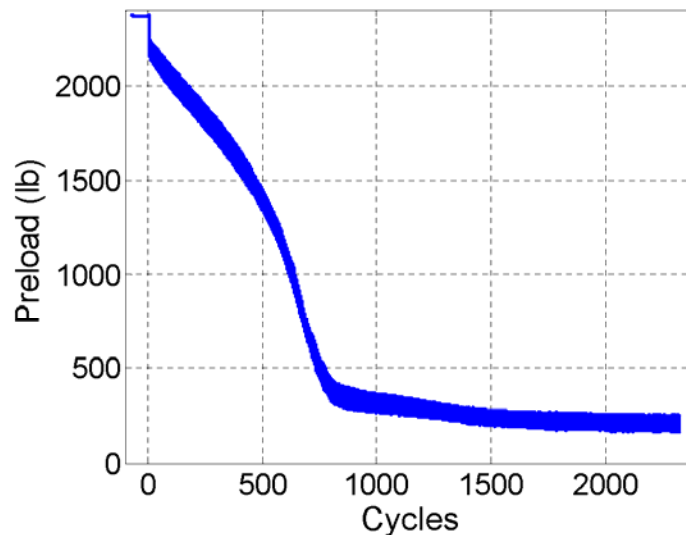

Figure C18 Preload versus cycles for "Locking Heli-Coil with Braycote" run number 18.



Title:

**Evaluate the Performance of Loctite® as a Secondary
Locking Feature for ISS Fasteners**

Page #:
138 of 205

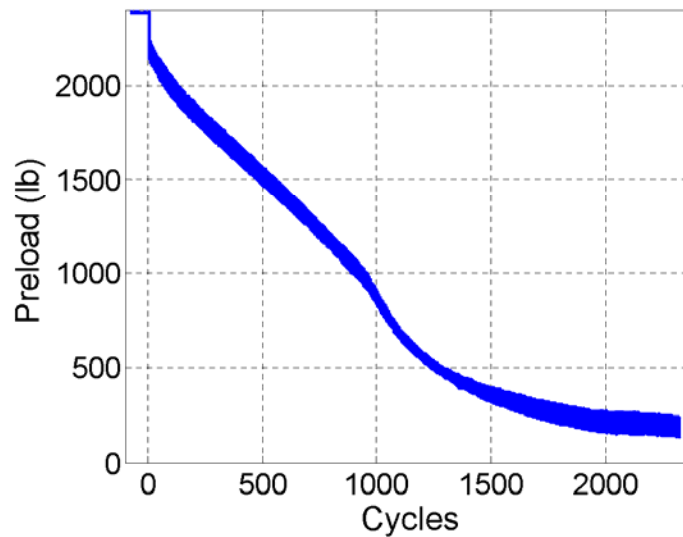

Figure C19 Preload versus cycles for "Locking Heli-Coil with Braycote" run number 19.

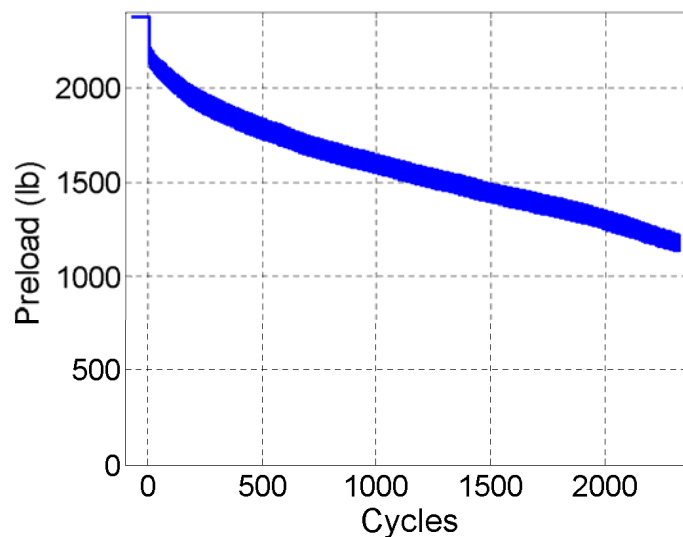

Figure C20 Preload versus cycles for "Locking Heli-Coil with Braycote" run number 20.



Title:

**Evaluate the Performance of Loctite® as a Secondary
Locking Feature for ISS Fasteners**

Page #:
139 of 205

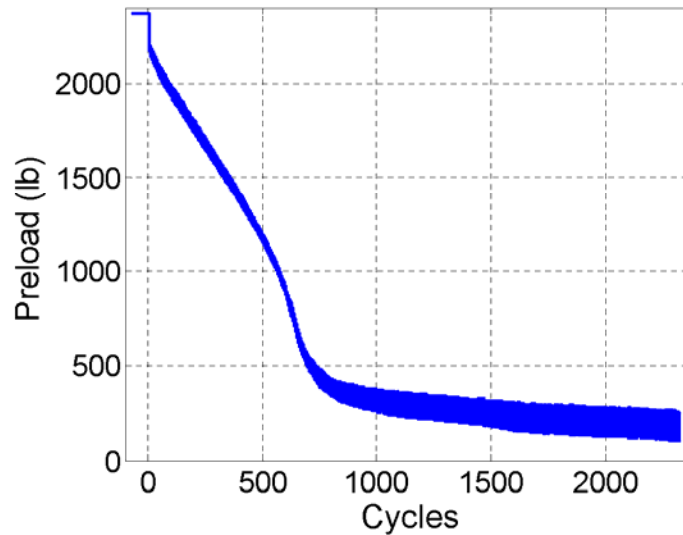

Figure C21 Preload versus cycles for "Locking Heli-Coil with Braycote" run number 21.

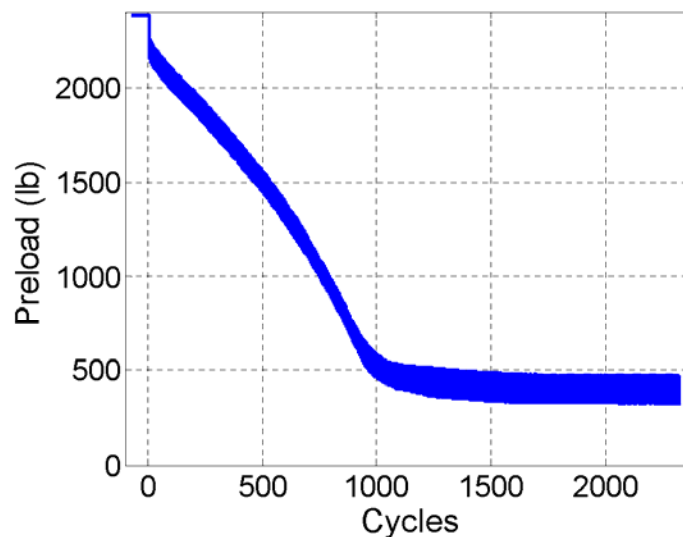

Figure C22 Preload versus cycles for "Locking Heli-Coil with Braycote" run number 22.



NASA Engineering and Safety Center Technical Assessment Report

Document #:
**NESC-RP-
04-092**

Version:
1.0

Title:

Evaluate the Performance of Loctite® as a Secondary Locking Feature for ISS Fasteners

Page #:
140 of 205

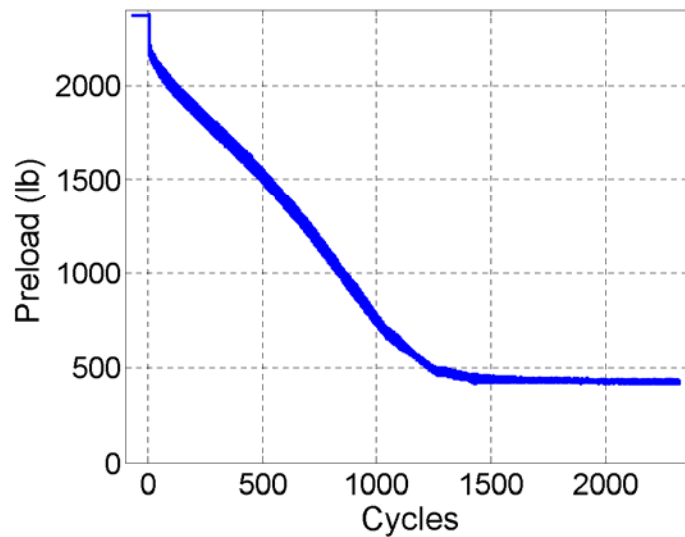

Figure C23 Preload versus cycles for "Locking Heli-Coil with Braycote" run number 23.

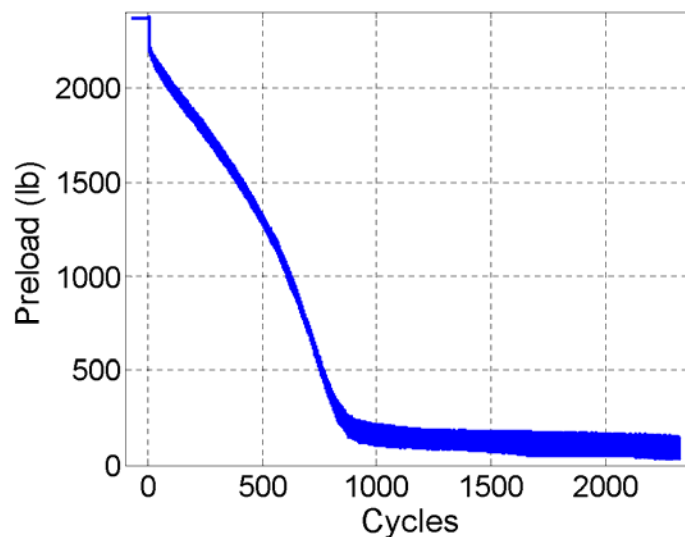

Figure C24 Preload versus cycles for "Locking Heli-Coil with Braycote" run number 24.



NASA Engineering and Safety Center Technical Assessment Report

Document #:
**NESC-RP-
04-092**

Version:
1.0

Title:

Evaluate the Performance of Loctite® as a Secondary Locking Feature for ISS Fasteners

Page #:
141 of 205

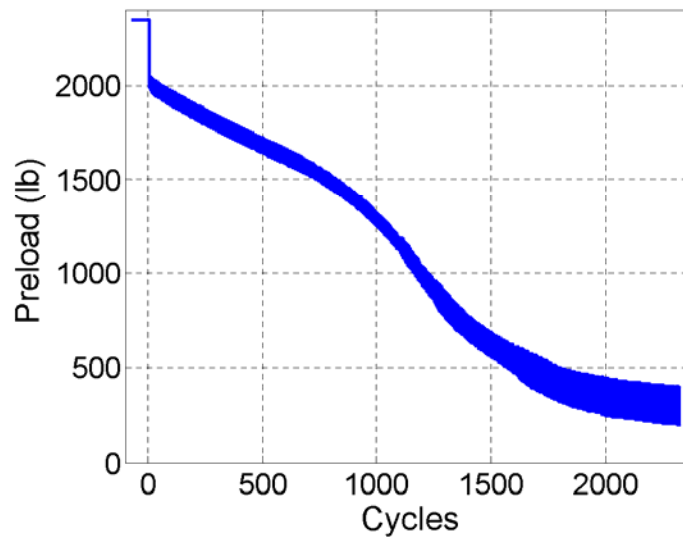

Figure C25 Preload versus cycles for "Standard Heli-Coil with Loctite" run number 25.

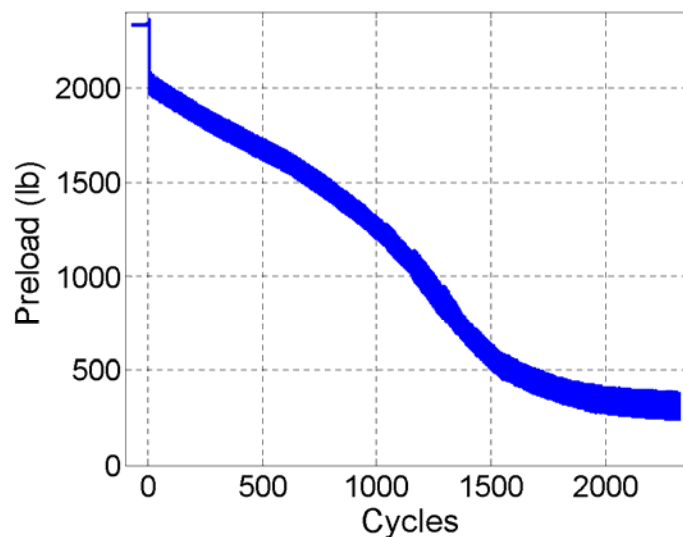

Figure C26 Preload versus cycles for "Standard Heli-Coil with Loctite" run number 26.



NASA Engineering and Safety Center Technical Assessment Report

Document #:
**NESC-RP-
04-092**

Version:
1.0

Title:

Evaluate the Performance of Loctite® as a Secondary Locking Feature for ISS Fasteners

Page #:
142 of 205

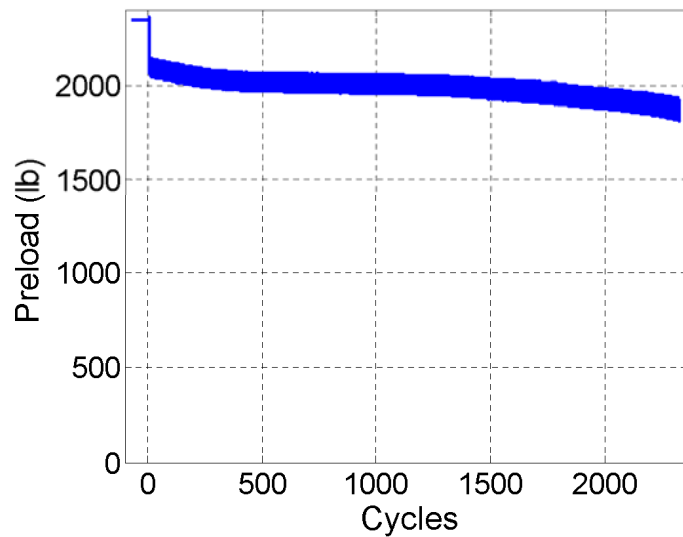

Figure C27 Preload versus cycles for "Standard Heli-Coil with Loctite" run number 27.

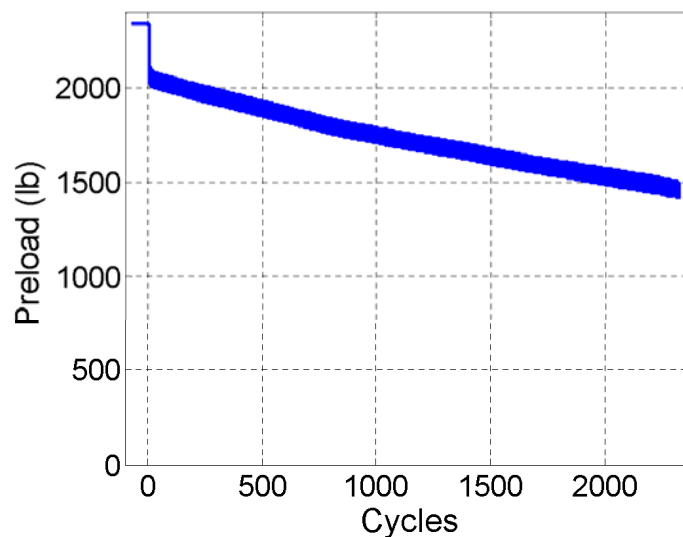

Figure C28 Preload versus cycles for "Standard Heli-Coil with Loctite" run number 28.



NASA Engineering and Safety Center Technical Assessment Report

Document #:
**NESC-RP-
04-092**

Version:
1.0

Title:

Evaluate the Performance of Loctite® as a Secondary Locking Feature for ISS Fasteners

Page #:
143 of 205

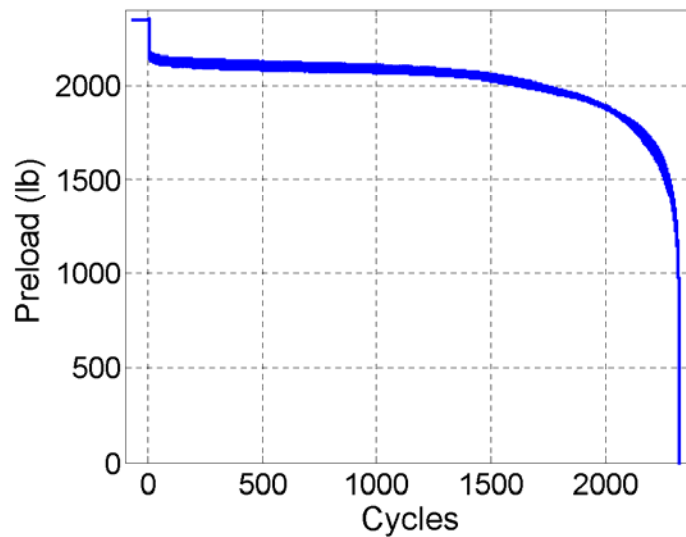

Figure C29 Preload versus cycles for "Standard Heli-Coil with Loctite" run number 29.

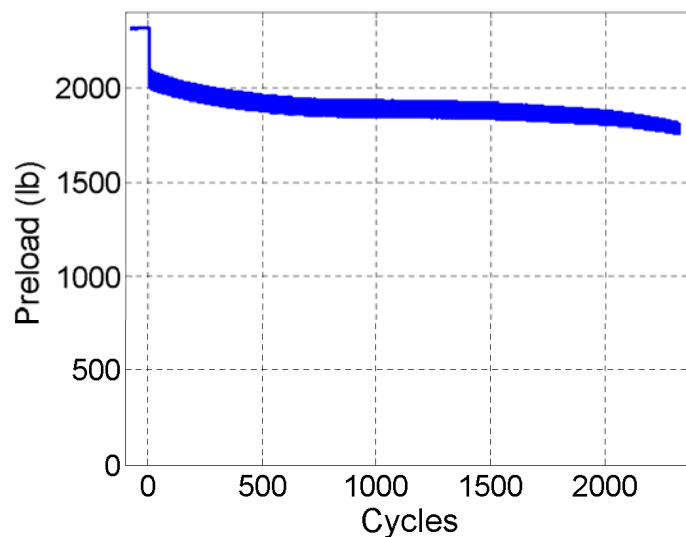

Figure C30 Preload versus cycles for "Standard Heli-Coil with Loctite" run number 30.



NASA Engineering and Safety Center Technical Assessment Report

Document #:
**NESC-RP-
04-092**

Version:
1.0

Title:

Evaluate the Performance of Loctite® as a Secondary Locking Feature for ISS Fasteners

Page #:
144 of 205

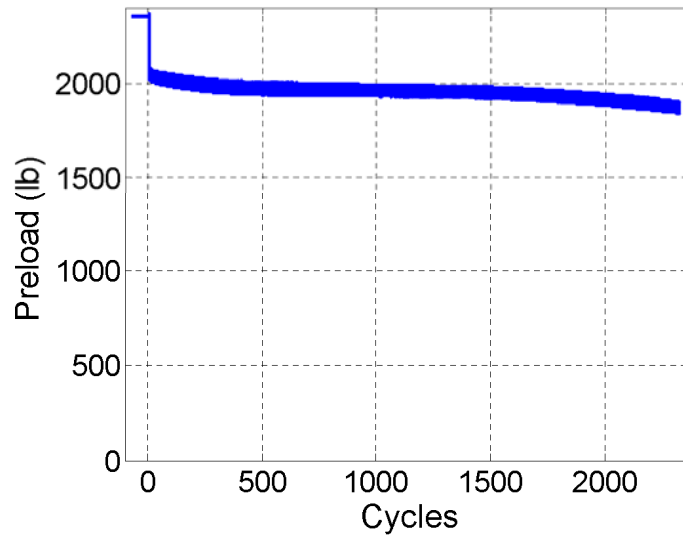

Figure C31 Preload versus cycles for "Standard Heli-Coil with Loctite" run number 31.

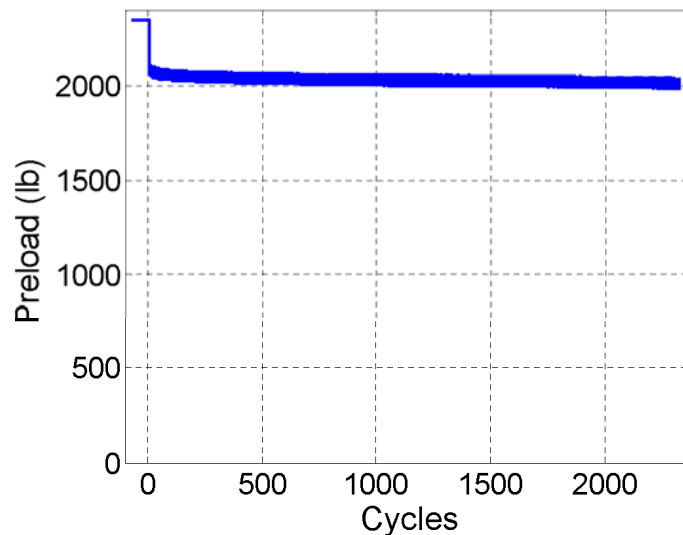

Figure C32 Preload versus cycles for "Standard Heli-Coil with Loctite" run number 32.



NASA Engineering and Safety Center Technical Assessment Report

Document #:
**NESC-RP-
04-092**

Version:
1.0

Title:

Evaluate the Performance of Loctite® as a Secondary Locking Feature for ISS Fasteners

Page #:
145 of 205

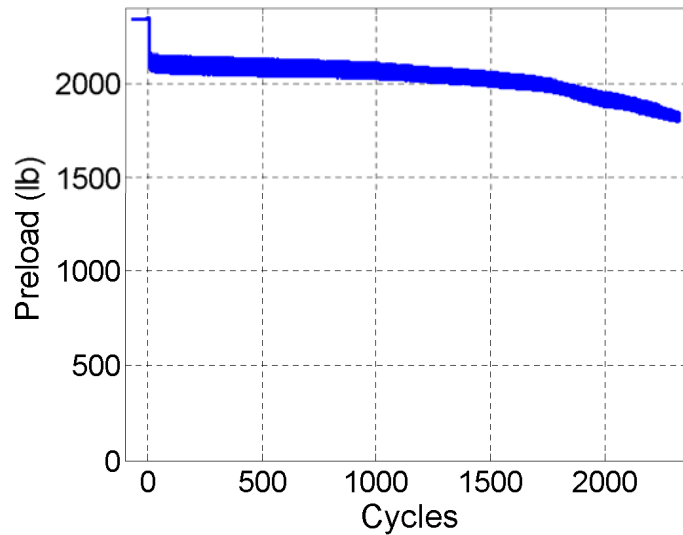

Figure C33 Preload versus cycles for "Standard Heli-Coil with Loctite" run number 33.

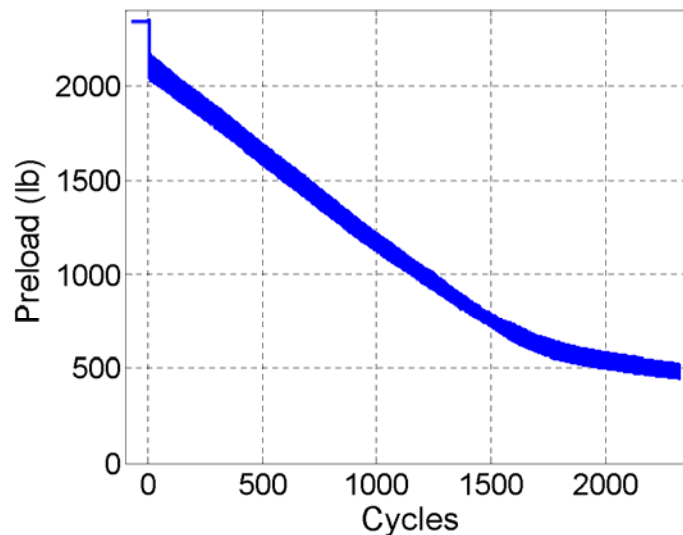

Figure C34 Preload versus cycles for "Standard Heli-Coil with Loctite" run number 34.



NASA Engineering and Safety Center Technical Assessment Report

Document #:
**NESC-RP-
04-092**

Version:
1.0

Title:

Evaluate the Performance of Loctite® as a Secondary Locking Feature for ISS Fasteners

Page #:
146 of 205

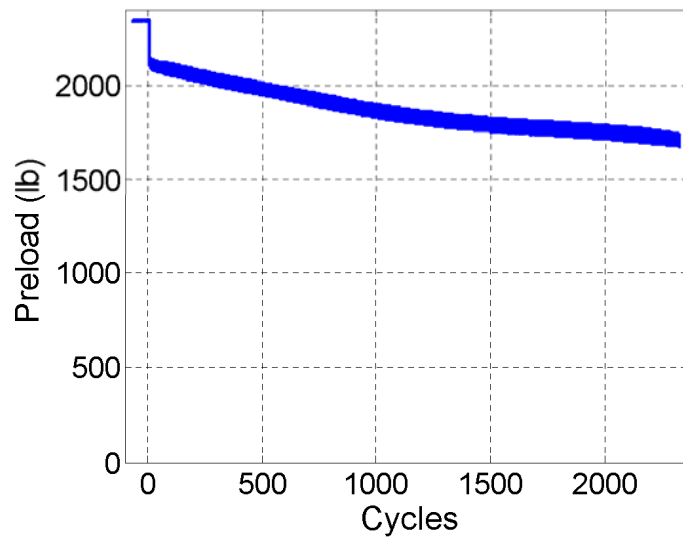

Figure C35 Preload versus cycles for "Standard Heli-Coil with Loctite" run number 35.

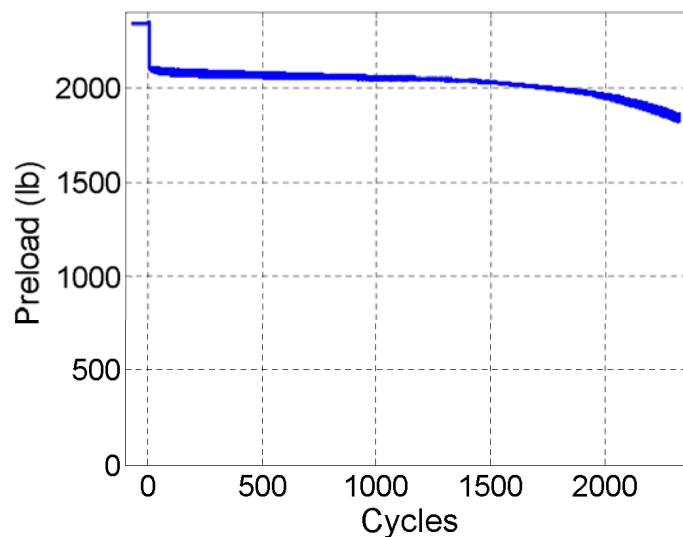



Figure C36 Preload versus cycles for "Standard Heli-Coil with Loctite" run number 36.

	NASA Engineering and Safety Center Technical Assessment Report	Document #: NESC-RP- 04-092	Version: 1.0
Title: Evaluate the Performance of Loctite® as a Secondary Locking Feature for ISS Fasteners		Page #: 147 of 205	

Appendix G. Thermal Vacuum Testing and Results

This work was conducted by NASA Personnel for the NESC.

To request the data information, please go to URL:
<http://www.nasa.gov/offices/nesc/home/index.html>

	<p align="center">NASA Engineering and Safety Center Technical Assessment Report</p>	<p>Document #: NESC-RP-04-092</p>	<p>Version: 1.0</p>
<p>Title: Evaluate the Performance of Loctite® as a Secondary Locking Feature for ISS Fasteners</p>		<p>Page #: 148 of 205</p>	

**Loctite Investigation
Thermal Vacuum Cycling Testing**

Evaluation of the Performance of Anaerobic Locking Compounds When Subjected to Thermal Cycling

February 9, 2007

Concurrence Signatures:

_____	_____
Thomas Levin	Date
Test Operator	

_____	_____
Richard A. Foss	Date
Facility Safety Head	

_____	_____
Amanda Cutright	Date
Test Engineer	

_____	_____
Kenny B. Elliott	Date
Technical Project Engineer	



**NASA Engineering and Safety Center
Technical Assessment Report**

Document #:
**NESC-RP-
04-092**

Version:
1.0

Title:

**Evaluate the Performance of Loctite® as a Secondary
Locking Feature for ISS Fasteners**

Page #:
149 of 205

Table of Contents

1.0	Introduction.....	4
2.0	Applicable Documents.....	5
3.0	Definitions.....	5
4.0	Facility and Environmental Requirements.....	6
4.1	Safety	6
4.2	Access Restrictions	6
4.3	Environmental and Cleanliness.....	6
4.4	Lifting and Handling.....	6
5.0	Quality Assurance Provisions	6
5.1	Nonconformance.....	7
5.2	Test Failure	7
5.2.1	Failure Criteria.....	7
5.2.2	Procedures Following Occurrence of Failure	7
5.2.3	Failure Reporting	8
6.0	Documentation Requirements.....	8
6.1	“As-Run” and Redline Documents	8
6.2	Test Log.....	9
6.3	Disposition.....	9
7.0	Test Equipment.....	10
7.1	Equipment List.....	10
7.2	Calibration.....	10
7.3	Vacuum Chamber	11
7.4	Test Article.....	11
7.4.1	Test Article Parts List	12
7.4.2	Test Article Handling.....	12
8.0	Thermal Vacuum Test.....	13
8.1	Test Description.....	13
8.2	Test Setup.....	13
8.2.1	Facility Preparation.....	13
8.2.2	Test Article Preparation	14
8.3	Test Procedure	14
8.3.1	Thermal Cycling Pre-Test.....	14
8.3.2	Thermal Cycling Life-Test	15
Appendix A	Test Article Assembly.....	17
Appendix B	Thread Locking Application Procedure.....	21
Appendix C	Fastener Removal.....	22
Appendix D	Data Sheets.....	23



**NASA Engineering and Safety Center
Technical Assessment Report**

Document #:
**NESC-RP-
04-092**

Version:
1.0

Title:

**Evaluate the Performance of Loctite® as a Secondary
Locking Feature for ISS Fasteners**

Page #:
150 of 205

List of Tables

Table 1.1	Test Matrix.....	4
Table 7.1	Test Instrumentation	10
Table 7.2	Environmental Conditions	11
Table 7.2	Test Article Part List.....	12
Table 6.2	Test article part list.....	19

List of Figures

Figure 1.1	Typical test sample	5
Figure 7.1	Fastener fixture assembly design.....	11
Figure 7.2	Fastener fixture assembly design installed on thermal vacuum hot-cold plate .	12
Figure 8.1	Thermal cycle profile.....	16
Figure 8.2	Test article removal schedule.....	16
Figure A.1	Sample fastener assembly	19
Figure A.2	Test article bolt fastener sample layout	20



NASA Engineering and Safety Center Technical Assessment Report

Document #:
NESC-RP-04-092

Version:
1.0

Title:

Evaluate the Performance of Loctite® as a Secondary Locking Feature for ISS Fasteners

Page #:
151 of 205

1.0 Introduction

The purpose of this test is to examine the performance of Loctite® as a secondary locking feature in a threaded fastening system subjected to extreme thermal and vacuum environments typical of the International Space Station. The tests are being conducted for the NASA Engineering Safety Center as part of an investigation into the use of anaerobic locking compounds in fastening systems used on the International Space Station [NESC Request 04-092-I].

Specifically, simulated bolted joints using Loctite® thread locker will be subjected to thermal cycling in a high vacuum environment. The breakloose torque, prevailing torque, and sample bolt axial load as a function of time will be recorded. The samples will be cycled between -100°C to 100°C in a vacuum at less than 10^{-5} torr. The simulated joint, shown in Figure 1.1, uses NAS1004, ¼-28 UNJF-3A bolts to clamp a cylinder to an aluminum base plate. Loctite® 242 is used as a thread locker. The cylinder material, shown in Table 1.1, is chosen to provide either a null temperature effect or a thermal load of approximately 1000 lbs. in the joint. The initial bolt pre-load is set such that the minimum bolt axial-load resulting from thermal effects is non-zero.

Table 1.1 Test Matrix

Bolt	Insert	Cylinder Material	Initial Pre-Load (lb)	Predicted Max. Axial Load (lb)	Predicted Min. Axial Load (lb)
NAS1004-22	MS124696	AL 6061-T6	650	1025	100
NAS1004-22	MS124696	A 286	650	655	645
NAS1004-22	MS124696	15-5	650	1300	210

This document defines the facility thermal-vacuum test requirements, test setup, instrumentation requirements, and test sequence for bolts with applied anaerobic thread lockers.



NASA Engineering and Safety Center Technical Assessment Report

Document #:
**NESC-RP-
04-092**

Version:
1.0

Title:

Evaluate the Performance of Loctite® as a Secondary Locking Feature for ISS Fasteners

Page #:
152 of 205

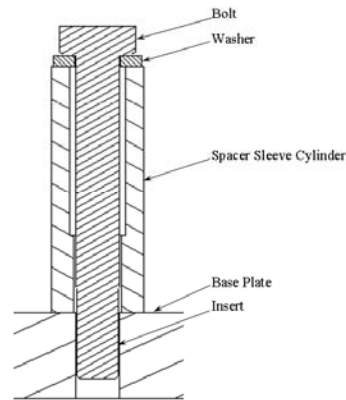

Figure 1.1 Typical test sample

2.0 Applicable Documents

The following documents apply to this procedure to the extent specified herein. Unless a specific issue or revision is listed, the applicable issue shall be that in effect on the date of these operations. In conflicts between the listed documents and the contents of this procedure, this procedure shall prevail.

LMS-CP-0506	Selection Use and Control of Inspection, Measuring, and Test Equipment
LMS-CP-5510	Aerospace Systems Change Control within Systems Engineering
LPR-1740.2	Facility Safety Requirements
LPR 1740.5	Procedure for Cleaning of Systems and Equipment for Oxygen Services
NPR 8621.1B	NASA Procedural Requirements for Mishap and Close Call Reporting, Investigating, and Recordkeeping

3.0 Definitions

Breakloose torque: The initial torque required to break the adhesive bond and decrease or eliminate the axial load in a preloaded assembly. The breakloose torque is measured at the first movement between the bolt and nut/insert.

Prevailing Torque: The torque measured after the initial breakage of the adhesive bond at specified angle of rotation of the nut.

	NASA Engineering and Safety Center Technical Assessment Report	Document #: NESC-RP-04-092	Version: 1.0
Title: Evaluate the Performance of Loctite® as a Secondary Locking Feature for ISS Fasteners		Page #: 153 of 205	

4.0 Facility and Environmental Requirements

The following subsections detail general facility and environmental requirements governing this procedure.

4.1 Safety

All personnel are responsible for maintaining a safe work environment. The Test Engineer and Test Operator shall assure that appropriate safe practices are implemented during these operations.

The Technical Project Engineer has final authority over safety provisions pertaining to the test article. The respective Facility Safety Head has the final authority over safety provisions of the facilities used for this test.

4.2 Access Restrictions

Access to the test areas shall be limited to test personnel and designated project personnel for the duration of this procedure.

4.3 Environmental and Cleanliness

Standard laboratory conditions are required during the assembly of the test articles (25 ± 5 °C, 0.8 to 1.0 bar, and 20 to 80 % relative humidity). The bolts and inserts are clean items and shall be handled using latex gloves. (See Section 7.4.2)

4.4 Lifting and Handling

The test article and fixtures are to be considered non-critical lift hardware. Lifting and handling operations shall be controlled by criteria provided in LPR 1740.2.

5.0 Quality Assurance Provisions

The following requirements and procedures are to be read, understood, and adhered to throughout the testing in this procedure. If any requirement or procedure is not understood, contact the Test Engineer for clarity prior to continuing with any test operation.

Responsibilities:

- a. The Test Engineer and Test Operator are responsible for implementing the QA provisions of this plan.
- b. The Test Engineer shall assure that the proper “As-Run Copy” has been prepared and is used for the operations defined herein.
- c. The Test Engineer shall assure that the proper “redlining” practices are used as described in Section .6.1.
- d. The Test Operator shall verify that all instrument calibrations are current and will not

	NASA Engineering and Safety Center Technical Assessment Report	Document #: NESC-RP-04-092	Version: 1.0
Title: Evaluate the Performance of Loctite® as a Secondary Locking Feature for ISS Fasteners		Page #: 154 of 205	

expire for the duration of this test.

- e. The Test Engineer shall initial log entries, procedural changes, and data sheets, as appropriate, to attest to the proper completion of these operations.

5.1 Nonconformance

A nonconformance is a condition or characteristic of the test software, or test equipment that does not conform to drawings or other specifications. For the test article, a nonconformance is a condition or characteristic that does not conform to the as-built configuration. All non-conformances shall be recorded in accordance with Section 5.2.3.

5.2 Test Failure

Test failure is any event that deviates from planned procedures, exceeds normal variations, or generates unexpected data. Test failures shall be divided into three types of failures; test article failures, test anomalies, or mishaps. These failures are defined in Section 5.2.1, the failure procedures are defined in Section 5.2.2, and the failure documentation is specified in Section 5.2.3.

5.2.1 Failure Criteria

- a. A test article failure is any event not due to human error, test equipment error, or procedural error that results in damage to the test article. Test article damage shall include but not be limited to joint failures, loose parts, structural failures, and structural performance failures.
- b. A test anomaly is any event that is the result of human error, test equipment error, or procedural error that does not affected the test article.
- c. A mishap, as defined in NPR 8621.1B, is any unplanned event that results in any one of the following: occupational injury or illness, injury to non-NASA personnel, damage to the facility, or gross damage to the test article.

5.2.2 Procedures Following Occurrence of Failure

During testing the Technical Project Engineer has full authority over issues or safety concerns pertaining to the test article. However, the facility safety head has full authority over issues or safety concerns pertaining to the test facility. The Technical Project Engineer shall be informed of all failures (test article, test anomaly, or mishap).

- a. Upon the occurrence of a failure, the procedure shall be terminated in an orderly and safe manner.
- b. The Test Operator or Test Engineer shall record each failure in accordance with Section 5.2.3. The Test Engineer shall review the failure, and shall inform the Technical Project Engineer that a failure has occurred.
- c. Minor troubleshooting may be done to assess the failure; however, no disassembly, instrument reconfiguration, software reconfiguration, or other actions that present a risk to the test article or present a risk of losing the failure mode, shall be allowed.

	NASA Engineering and Safety Center Technical Assessment Report	Document #: NESC-RP-04-092	Version: 1.0
Title: Evaluate the Performance of Loctite® as a Secondary Locking Feature for ISS Fasteners			Page #: 155 of 205

d. If the failure is a test anomaly, corrective action shall be taken and documented in the test log. Testing may continue with the concurrence of the Technical Project Engineer, Test Engineer, and Test Operator. Their approval shall be indicated by placing their initials and the current date and time into the test-log. All troubleshooting steps and results shall be recorded in the test log.

e. If the failure is a mishap, the following contacts shall be notified:

Emergency Dispatch Office	Extension	911 or 45600
Systems Integration and Test Branch Head,	Richard Foss	
	Extension:	47049
	Home Phone:	757-357-0380
Technical Project Engineer	Extension:	757-864-4359

Until the proper emergency response personnel arrive, the test personnel shall limit all access to the test facility, and they shall ensure that no disassembly, instrument reconfiguration, software reconfiguration, or other actions that present a risk to the test article or present a risk of losing the failure mode be performed.

f. If the failure is a test article failure, then the Test Engineer shall notify the Technical Project Engineer of the failure. Testing may continue at the discretion of the Technical Project Engineer with the concurrence of the Test Engineer. Their approval shall be indicated by placing their initials and the current date into the test-log. All troubleshooting steps and results shall be recorded in the test log.

5.2.3 Failure Reporting

All failures are to be documented in the test-log.

6.0 Documentation Requirements

The following requirements are to be read, understood, and adhered to throughout the testing in this procedure. If any requirement is not understood, contact the Test Engineer for clarity prior to continuing with any test operation.

6.1 “As-Run” and Redline Documents

Prior to any operations governed by this procedure, one copy of this document shall be marked “AS-RUN COPY”. All pertinent data taken during the run shall be recorded in this copy.

Any changes identified during the performance of this procedure shall be redlined into the “As-Run Copy”. The Test Engineer, Test Operator, and Technical Project Engineer shall indicate their approval by placing their initials and the current date next to each redline before it is applied. Changes to the test criteria or basic objective of this test plan are not allowed without the re-issue of this document.

Running a redlined procedure shall require written authorization by the Technical Project Engineer, Test Engineer, and Test Operator.

	NASA Engineering and Safety Center Technical Assessment Report	Document #: NESC-RP-04-092	Version: 1.0
Title: Evaluate the Performance of Loctite® as a Secondary Locking Feature for ISS Fasteners			Page #: 156 of 205

6.2 Test Log

The Test Engineer shall maintain a test log for the operations governed by this procedure. As a minimum the test log shall include:

- a. A chronological listing of all activities and related events that occurred during the performance of this procedure.
- b. Test Data Sheets generated during the course of testing
- c. A detailed discussion of any procedural changes.
- d. A detailed discussion of any changes to the test article made during this procedure.
- e. A detailed discussion of authorized activities not originally planned.
- f. A detailed discussion of any test failures.

6.3 Disposition

When the prescribed operations are completed (including failed and aborted tests), the “As-Run Copy,” test log, and all associated data shall be reviewed by the Test Engineer.

Following review by the Technical Project Engineer and Test Engineer, a test report shall be prepare and forwarded to the Technical Project Engineer.

Formal revision and re-issue of this document, to incorporate redlines, shall be accomplished in accordance with LMS-CP-5510.



NASA Engineering and Safety Center Technical Assessment Report

Document #:
**NESC-RP-
04-092**

Version:
1.0

Title:

Evaluate the Performance of Loctite® as a Secondary Locking Feature for ISS Fasteners

Page #:
157 of 205

7.0 Test Equipment

The following sections list equipment required for the performance of this procedure. The list is provided for the convenience of the Test Engineer and Test Operator, so that arrangements may be made for the availability and calibration of equipment prior to the test. Equipment with equivalent characteristics may be substituted at the discretion of the Test Engineer. A complete list of equipment used during this procedure including part numbers, equipment control numbers, serial numbers, and calibration dates shall be recorded in the test log.

7.1 Equipment List

The facility shall supply all equipment and instrumentation necessary for the operations of the chamber. The following table list the instrumentation required in addition to the chamber instrumentation.

Table 7.1 Test Instrumentation

Item	Description	Quantity
Thermocouple	Each test article (10) shall be instrumented with a minimum of one thermocouple suitable for measuring base plate temperatures between -100 and +100 °C	10
Instrumented Bolt	Each test article (10) shall be instrumented with two (2) bolts capable of measuring the bolt axial load from 0-1000 lb.	20
Data System	The facility shall supply a data system suitable to measure all chamber parameters (temp. and pressure) as well as the test article instrumentation. Data shall be recorded to a format suitable for import into Excel at a sample rate of 1 sample set every 10 minutes. Measurements shall include: Chamber housekeeping parameters Chamber pressure Test article base plate temperature (10) Bolt axial load (20)	1
Dial Indicator Torque Wrench	TBD	1

7.2 Calibration

Selection and use of measurement equipment used for the operations defined herein shall be in accordance with LMS-CP-0506.



Title:

**Evaluate the Performance of Loctite® as a Secondary
Locking Feature for ISS Fasteners**

Page #:
158 of 205

7.3 Vacuum Chamber

A vacuum chamber suitable for accommodating the test article and test environments shall be used for this test. The facility shall supply all equipment and instrumentation necessary for the operations of the chamber.

Table 7.2 Environmental Conditions

Item	Description
Maximum Temperature *	+100 ±5 °C
Minimum Temperature *	-100 ±5 °C
Min. Ramp Rate Hot-to-Cold *	1 °C/min
Min. Ramp Rate Cold-to-Hot *	1 °C/min
Vacuum	<10 ⁻⁵

* - temperatures measured at the base plate of the test article.

7.4 Test Article

The test article, shown in Figure 7.1, consists of a base plate containing twenty-five simulated fastener joints. Ten test articles are mounted to a hot/cold plate that is mounted in a bell jar; Figure 7.2. The test article is designed to test threaded fasteners using an anaerobic adhesive as a thread locker. The simulated joint, shown in Figure 1.1, uses NAS1004, ¼-28 UNJF-3A bolts to clamp a cylinder to the aluminum base plate. Loctite® 242 is used as the thread locker. The cylinder material, shown in Table 1.1, is chosen to provide either a null temperature effect or a thermal load of approximately 1000 lbs. in the joint. The initial bolt pre-load is set such that the minimum bolt axial-load resulting from thermal effects is non-zero. The predicted thermal and mechanical loads are given in Table 1.1.

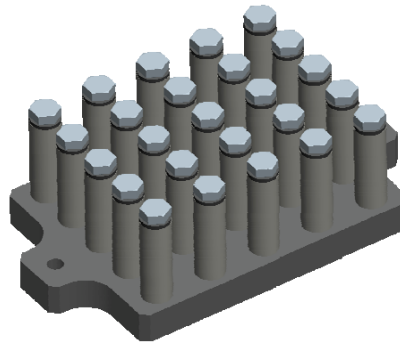

Figure 7.1 Fastener fixture assembly design



NASA Engineering and Safety Center Technical Assessment Report

Document #:
**NESC-RP-
04-092**

Version:
1.0

Title:

Evaluate the Performance of Loctite® as a Secondary Locking Feature for ISS Fasteners

Page #:
159 of 205

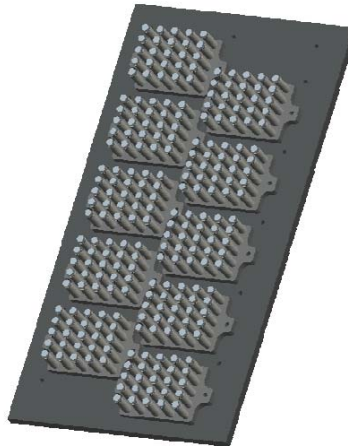

Figure 7.2 Fastener fixture assembly design installed on thermal vacuum hot-cold plate

7.4.1 Test Article Parts List

Table 7.2 Test Article Part List

Item	Drawing/Part Number	Quantity
Base Plate Assembly	1247033-1	
Base Plate	1247036-1	10
Spacer Sleeve (AL 6061)	1247032-1	100
Spacer Sleeve (A-286 Cres)	1247032-3	100
Spacer Sleeve (15-5 Cres)	1247032-5	50
Insert	1191-4CN375	250
Washer	NAS1149C0463	250
Bolt	NAS1004-22	230
Instrumented Bolt	TBD	20
Adhesive	Loctite® 242	
Activator	Loctite® 7471	

7.4.2 Test Article Handling

Fasteners and base plates are cleaned to cleanliness Level A of LPR 1740.5. Prior to assembly of the test article, fasteners and base plates are to be handled with gloves to prevent contamination of the threaded surfaces. After test article assembly, no contamination control is required.

	NASA Engineering and Safety Center Technical Assessment Report	Document #: NESC-RP-04-092	Version: 1.0
Title: Evaluate the Performance of Loctite® as a Secondary Locking Feature for ISS Fasteners			Page #: 160 of 205

8.0 Thermal Vacuum Test

The following requirements and procedures are to be read, understood, and adhered to throughout the testing in this procedure. If any requirement or procedure is not understood, contact the Test Engineer for clarity prior to continuing with any test operation.

8.1 Test Description

The test is a thermal-cycle fixed-life test. Ten test articles, described in Section 7.4, are thermally cycled in a vacuum environment. The environmental conditions are representative of near maximum conditions experienced by components located on the exterior of the International Space Station. At specified time intervals, a test article is removed from the environment. Bolt breakloose torque and prevailing torque are measured to determine the effect of the environment on the adhesive qualities of the thread locker used in the joint.

Each of the ten test articles are instrumented with thermocouples and load sensing joint bolts. The thermocouples are used for measuring the approximate joint temperature. The load sensing bolts are used to measure typical joint axial load during the thermal cycling.

8.2 Test Setup

8.2.1 Facility Preparation

The Test Operator shall insure that the test facility is ready for operations by certifying the following:

- a. Verify that all appropriate instrumentation is available, in working order, and, where appropriate, calibrated.
- b. Verify vacuum chamber (including pass-thru's, instrumentation, and data system) is configured and ready for test operations.

Test Facility ready for test: _____ Date: _____

Test Operator



NASA Engineering and Safety Center Technical Assessment Report

Document #:
**NESC-RP-
04-092**

Version:
1.0

Title:

Evaluate the Performance of Loctite® as a Secondary Locking Feature for ISS Fasteners

Page #:
161 of 205

8.2.2 Test Article Preparation

Prior to the start of the testing the test article shall be certified ready for test operations by confirming the following:

***** TO ALLOW FOR PROPER ADHESIVE CURE, CHAMBER OPERATIONS MUST BEGIN NO LESS THAN 24 HOURS OR NO MORE THAN 48 HOURS AFTER THE TEST ARTICLE ASSEMBLY. *****

- a. Verify all part are available and ready for test,
- b. Prepare fastener samples by cleaning the bolts and base plate assemblies to a Level A cleanliness level as per LPR 1740.5 (less than 1.0 mg/(0.1m²) NVR).
- c. Within 24-48 hours of chamber operations, assemble the test articles per Appendix A.

Test Article ready for test: _____ **Date:** _____
Test Engineer

8.3 Test Procedure

8.3.1 Thermal Cycling Pre-Test

A thermal cycling pre-test shall be performed to establish the cycling parameters used during the test.

1. Install test article thermal simulators on the chamber hot/cold plate. Torque ¼-20 attachment bolts to 30 in-lbs.
2. Cycle the chamber, at vacuum, from hot to cold and cold to hot at the maximum chamber rate to establish the minimum hot-to-cold and cold-to-hot ramp rates. The ramp rates shall be sufficient to reach the set point temperatures in a minimum time with less than 5 °C overshoot.

Ramp rate, hot-to-cold: _____ **TE:** _____

Ramp rate, cold-to-hot: _____ **TE:** _____

3. At the temperature extremes (+100 and -100 °C) determine the hold time required for all test articles to reach a stable temperature of the set point ±5 °C.

Hold time, cold: _____ **TE:** _____

Hold time, hot: _____ **TE:** _____



NASA Engineering and Safety Center Technical Assessment Report

Document #:
**NESC-RP-
04-092**

Version:
1.0

Title:

Evaluate the Performance of Loctite® as a Secondary Locking Feature for ISS Fasteners

Page #:
162 of 205

8.3.2 Thermal Cycling Life-Test

***** TO ALLOW FOR PROPER ADHESIVE CURE, CHAMBER OPERATIONS MUST BEGIN NO LESS THAN 24 HOURS OR NO MORE THAN 48 HOURS AFTER THE TEST ARTICLE ASSEMBLY. *****

1. Install the ten test articles onto the hot/cold plate as shown in Figure 7.2. Torque ¼-20 attachment bolts to 30 in-lbs.
2. Install and verify (end-to-end check) test article and chamber instrumentation.
3. Closeout the chamber. Begin data acquisition.
4. Pump down the chamber to less than 1×10^{-5} torr before beginning thermal cycle operations.
5. Thermally cycle the test articles to the profile shown in Figure 8.1 using the cycling parameters determined in Section 8.3.1 as guidelines. Record cycling parameters below:

Ramp rate, hot-to-cold:	_____	TE:	_____	<input checked="" type="checkbox"/>
Ramp rate, cold-to-hot:	_____	TE:	_____	<input checked="" type="checkbox"/>
Hold time, cold:	_____	TE:	_____	<input checked="" type="checkbox"/>
Hold time, hot:	_____	TE:	_____	<input checked="" type="checkbox"/>

6. Continue thermal cycling using the schedule shown in Figure 8.1 as a guideline. The first two test articles should be removed at eight day intervals. The remaining test articles should be removed on a four day interval. Chamber breaks shall occur during the transition from cold-to-hot. To avoid condensation, chamber venting shall occur when the chamber hot/cold plate temperature is greater than the ambient dew-point temperature. Following each test article removal, the procedure of Appendix C shall be followed to determine the breakloose torque and prevailing torque.



NASA Engineering and Safety Center Technical Assessment Report

Document #:
**NESC-RP-
04-092**

Version:
1.0

Title:

Evaluate the Performance of Loctite® as a Secondary Locking Feature for ISS Fasteners

Page #:
163 of 205

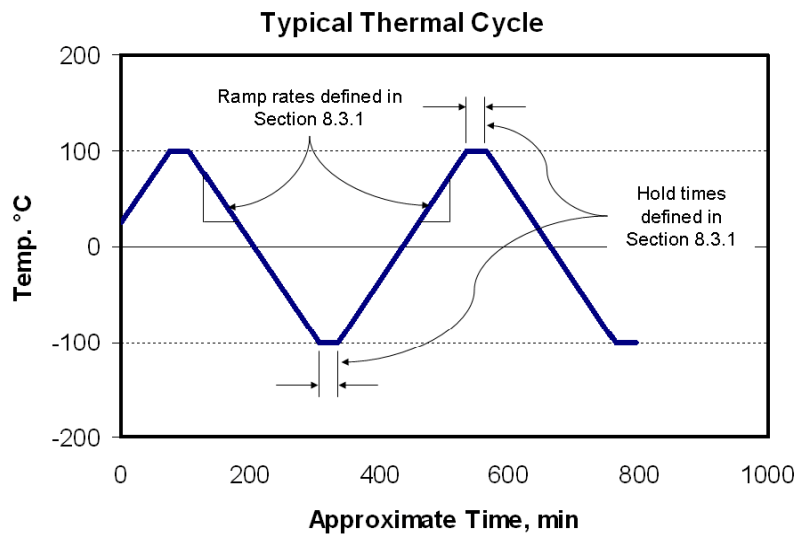

Figure 8.1 Thermal cycle profile

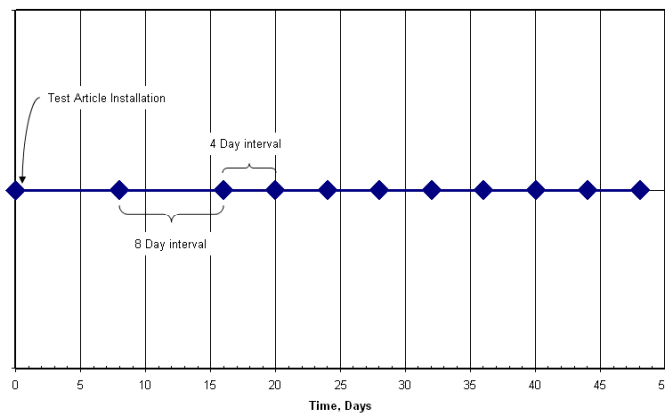



Figure 8.2 Test article removal schedule

	NASA Engineering and Safety Center Technical Assessment Report	Document #: NESC-RP-04-092	Version: 1.0
Title: Evaluate the Performance of Loctite® as a Secondary Locking Feature for ISS Fasteners			Page #: 164 of 205

Appendix A Test Article Assembly

***** To allow for proper adhesive cure, Chamber operations must begin no less than 24 hours or no more than 48 hours after the test article assembly. *****

Each test article is made up of 25 fastener samples. NAS1004 bolts are used to clamp a spacer sleeve to a base plate as shown in Figure A.1. The spacer sleeves are made from three different materials, aluminum (6061-T6) and two different stainless steels (A-286 and 15-5). Each test article assembly will include ten (10) fasteners with aluminum spacers, ten (10) fasteners with A-286 spacers, and five (5) fasteners with 15-5 spacers. Two of the twenty-five fasteners will use load sensing bolts to measure the preload of the bolt. One instrumented bolt will be used with an aluminum spacer, while the other will be used with an A-286 spacer. The fasteners will be installed in groups on the base plate. The groups and fastener location numbers are shown in Figure A.2. The following procedure is to be read, understood, and adhered to throughout the testing described herein. If any part of the procedure is not understood, contact the Test Engineer for clarity prior to continuing with any test operation.

1. Verify that the parts, shown in Table A.1, are available and ready for assembly.
2. Verify that the bolts and base plates assemblies have been cleaned to a Level A cleanliness level as per LPR 1740.5 (less than 1.0 mg/(0.1m²) NVR). Note: Prior to assembly of the test article, fasteners and base plates are to be handled with gloves to prevent contamination of the threaded surfaces. After the test article is assembled, no contamination control is required.
3. Layout the ten (10) base plate assemblies on a suitable clean work surface.
4. Install the twenty (20) instrumented bolts in the base plate assemblies. Each plate shall contain two instrumented bolts. One bolt shall be installed using an aluminum spacer, and one bolt shall be installed with an A-286 stainless steel spacer. The instrumented bolt installation procedure follows:
 - a. Verify the instrumented bolt includes a washer under the head.
 - b. Remove the washer keeper.
 - c. Install the spacer sleeve.
 - d. Install the instrumented bolt assembly (bolt, washer, and sleeve) into the base plate assembly using Loctite® 242 as per Appendix B. The location of the bolt assembly shall be chosen at random within the area designated for the sleeve material shown in Figure A.2. (Locations 1-10 for the aluminum sleeve and locations 11-20 for the A-286 stainless steel sleeve.)
 - e. The bolts shall be run-in by hand until snug (all mating surfaces in contact – no preload).
 - f. The bolt instrumentation wiring shall be connected to a data system to provide a reading of the bolt's measured axial load.
 - g. The bolt shall be preloaded using a dial indicator torque wrench until the preload value given in Table 1.1 is achieved. The final preload and torque



NASA Engineering and Safety Center Technical Assessment Report

Document #:
**NESC-RP-
04-092**

Version:
1.0

Title:

Evaluate the Performance of Loctite® as a Secondary Locking Feature for ISS Fasteners

Page #:
165 of 205

values shall be recorded.

h. Remove excess adhesive using absorbent cloth.

5. Determine an installation torque by averaging the installation torques determined during the instrumented bolt installation.

Installation Torque: _____ **TE:** _____

6. Select ninety (90) bolts and install into the base plate assemblies using the following procedure.

- a. Assemble a bolt, washer, and aluminum spacer sleeve.
- b. On each base plate assembly, install the bolt assembly using Loctite® 242 as per Appendix B in the remaining locations (Locations 1 through. 10) specified for aluminum spacer sleeves shown in Figure A.2.
- c. Run the bolts in by hand until snug (all mating surfaces in contact – no preload).
- d. Preload bolt using a clicker style torque wrench set to the installation torque specified in Step 5.
- e. Remove excess adhesive using absorbent cloth.

7. Select ninety (90) bolts and install into the base plate assemblies using the following procedure.

- a. Assemble a bolt, washer, and A-286 stainless steel spacer sleeve.
- b. On each base plate assembly, install the bolt assembly using Loctite® 242 as per Appendix B in the remaining locations (Locations 11 through. 20) specified for A-286 stainless steel spacer sleeves shown in Figure A.2.
- c. Run the bolts in by hand until snug (all mating surfaces in contact – no preload).
- d. Preload bolt using a clicker style torque wrench set to the installation torque specified in Step 5.
- e. Remove excess adhesive using absorbent cloth.

8. Select fifty (50) bolts and install into the base plate assembly using the following procedure.

- a. Assemble a bolt, washer, and 15-5 stainless steel spacer sleeve.
- b. On each base plate assembly, install the bolt assembly using Loctite 242 as per Appendix B in the remaining locations (Locations 21 through. 25) specified for 15-5 stainless steel spacer sleeves shown in Figure A.2.
- c. Run the bolts in by hand until snug (all mating surfaces in contact – no preload).
- d. Preload bolt using a clicker style torque wrench set to the installation torque specified in Step 5.



NASA Engineering and Safety Center Technical Assessment Report

Document #:
**NESC-RP-
04-092**

Version:
1.0

Title:

Evaluate the Performance of Loctite® as a Secondary Locking Feature for ISS Fasteners

Page #:
166 of 205

- e. Remove excess adhesive using absorbent cloth.

Table 6.2 Test article part list

Item	Drawing/Part Number	Quantity
Base Plate Assembly	1247033-1	10
Cylinder (AL 6061)	1247032-1	90
Cylinder (A 286 Cres)	1247032-3	90
Cylinder (15-5 Cres)	1247032-5	50
Washer	NAS1149C0463	250
Bolt	NAS1004-22A	230
Instrumented bolt	TBD	20
Adhesive	Loctite® 242	
Activator	Loctite® 7471	

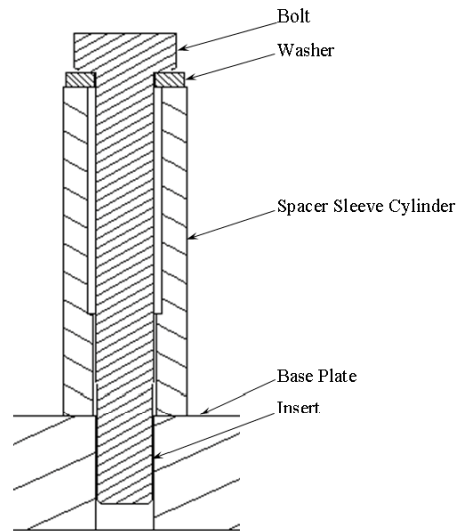

Figure A.1 Sample fastener assembly



NASA Engineering and Safety Center Technical Assessment Report

Document #:
**NESC-RP-
04-092**

Version:
1.0

Title:

Evaluate the Performance of Loctite® as a Secondary Locking Feature for ISS Fasteners

Page #:
167 of 205



Figure A.2 Test article bolt fastener sample layout

	NASA Engineering and Safety Center Technical Assessment Report	Document #: NESC-RP- 04-092	Version: 1.0
Title: Evaluate the Performance of Loctite® as a Secondary Locking Feature for ISS Fasteners			Page #: 168 of 205

Appendix B Thread Locking Application Procedure

1. Apply activator (Loctite® 7471) to all threaded mating surface of the joint.
2. Allow activator to set for a minimum of 15 minutes prior to the application of adhesive.
3. Thoroughly shake the adhesive (Loctite® 242) before applying to the threaded surfaces.
4. Apply adhesive (Loctite® 242) to the threaded mating surfaces of the joint (bolt threads and insert threads) using a droplet method. Apply sufficient adhesive to ensure complete mating thread coverage in the joint. However, use only as much adhesive as required to ensure thread coverage. Excess adhesive shall be removed by blotting with a clean cloth.
5. Immediately assemble the fastener, and properly torque the fastener as per procedure.
6. After fastener assembly, allow the adhesive a minimum of twenty-four (24) hours, at stand laboratory conditions, to cure.

	NASA Engineering and Safety Center Technical Assessment Report	Document #: NESC-RP-04-092	Version: 1.0
Title: Evaluate the Performance of Loctite® as a Secondary Locking Feature for ISS Fasteners		Page #: 169 of 205	

Appendix C Fastener Removal

The procedure below shall be used for the removal of the sample fasteners from the test article.

1. Prior to the removal of the test article from the chamber and the subsequent disconnect of the axial load measurement cabling, record the room temperature/pressure axial load in the load sensing bolts.
2. Remove the test article from the chamber.
3. Secure the test article to a suitable bench-top.
4. Unscrew each bolt sample by applying a constant torque in the loosening direction such that the breakloose torque is attained in 5 to 10 seconds. Continue applying torque for a minimum of two complete rotations of the bolt. Record the breakloose torque and prevailing torque values at 90, 180, 270, 360, 450, 540, 630, and 720 degrees of bolt rotation.

	NASA Engineering and Safety Center Technical Assessment Report	Document #: NESC-RP- 04-092	Version: 1.0
Title: Evaluate the Performance of Loctite® as a Secondary Locking Feature for ISS Fasteners			Page #: 170 of 205

Appendix D Data Sheets

Page intentionally left blank

	NASA Engineering and Safety Center Technical Assessment Report	Document #:	Version:
		NESC-RP-04-092	1.0
Title:			Page #:
Evaluate the Performance of Loctite® as a Secondary Locking Feature for ISS Fasteners			173 of 205

Appendix H. Human Factors Review of Application Process for Liquid Locking Compounds (LLC) in ISS Hardware

Loctite® is an LLC, although there are other brands of LLC's. "LLC" and the trade name "Loctite®" are used interchangeably. The three standards below were reviewed and inconsistencies/incongruities among the standards assessed, including descriptions of activators/primers, cure time and the activator/primers, activator/primers and inactive metals, and the application of LLCs on fastening hardware. Current information obtained from the Loctite® manufacturer regarding certain application features was also assessed.

H.1 Relevant Standards Documents

MIL-S-22473E "Military Specification: Sealing, Locking, and Retaining Compounds: (Single Component)" (dated 12 Apr 1983, and cancelled 21 Jan 2004) lists and specifies 15 separate compound GRADES (listed as letters from AA to JV) based on viscosity and locking torque. MIL-S-22473E does NOT cover any of the liquid locking compounds used in the tests conducted by this NESC (i.e., Loctite® 222, 242, and 271). This Mil Spec's Table I lists "locking torque" (not further defined) standards for the 15 compounds for a 3/8" x 24TPI plain steel bolt.

MIL-S-22473E also specifies two grades of "surface primers and cleaners" (grades "N" and "T"). MIL-S-22473E alludes to primer's activating function on inactive metals in the following statements (although the terms "activation" or "activator" are not used): Either surface primer grade specified in this Mil Spec, "...when applied to unpolished and untreated cadmium or zinc surfaces [assume this means any passivated or inactive metal surface], shall cause polymerization..." [of the 15 sealant grades]. However MIL-S-22473E does NOT mention stainless steel or titanium as inactive metals suitable for use with liquid locking compounds. MIL-S-22473E describes the "surface primer/cleaners" Grade "N" and Grade "T," which includes (Loctite® 7471, or grade "T") used in the tests conducted by the NESC.

MIL-S-22473E (section 4.6.2.1.1) describes the application of liquid locking compound, in performing the QA tests, as follows: "...sufficient compound shall be applied by means of the application nozzle supplied with the product to cover completely the protruding threads of the bolt." No mention is made of whether the LLC is applied to male threads, female threads, or to both.

MIL-S-46163A "Military Specification: Sealing, Lubricating and Wicking Compounds: Thread-Locking, Anaerobic, Single-Component" (dated 12 Jul 1983, and inactivated for new design 23 Mar 2001) specifies three separate types of compounds, each containing three separate compound GRADES, for a total of nine compounds. The three types are I, Sealing type (standard viscosity); type II, Lubricating type (thixotropic -- which thin when subjected to strains greater than the yield strain and regain thickness after rest); and type III, and Wicking type (fast curing, low viscosity). None of the nine compound letter grades specified in MIL-S-46163A

	NASA Engineering and Safety Center Technical Assessment Report	Document #: NESC-RP-04-092	Version: 1.0
Title: Evaluate the Performance of Loctite® as a Secondary Locking Feature for ISS Fasteners			Page #: 174 of 205

appeared in MIL-S-22473E. MIL-S-46163A Table II specifies viscosity of the nine compounds. In Table II there are comparable viscosities to those listed in MIL-S-22473E Table I for only three of the nine compounds. Also the locking torque standards specified in MIL-S-46163A Table III are not the same as the torque standards listed in MIL-S-22473E Table I. It is clear that the two MIL Specs are dealing with different types of liquid locking compounds. There is NO overlap in the LLCs described in MIL-S-22473E and MIL-S 46163A, nor is there redundancy in the primer/activators described in the two MIL Specs.

MIL-S 46163A is very specific in referring to LLCs for thread-locking. Section 6.1 describes these compounds as "...liquid and in use, are converted to an infusible, insoluble state by confinement between closely fitting metal surfaces (under anaerobic conditions)." Further, they are "...designed to lock threaded assemblies against working loose under shock and vibration." That section describes the three "types" of LLC as follows: "Type I compounds are intended for use in sealing threaded fasteners, plugs, and other threaded fittings against fluid pressure. Type II compounds (having excellent lubricity) allow a minimum of metal to metal friction, thus reducing galling on the thread flanks. Type III compounds, which have a low viscosity, are intended for use in closely fitting joints or for application to the outside of an assembled joint into which the compound flow by capillary action and cures."

MIL-S 46163A introduces "Prevailing Torque", in addition to "Locking Torque", as a metric for QA testing of liquid locking compounds. Table III lists both prevailing and locking torque values for plated-, as well as plain-steel 3/8" NC (16TPI) Grade 5 fasteners. Locking torque is stated to be "breakaway torque" (otherwise undefined), while prevailing torque is defined as the average torque values at 1/4, 1/2, 3/4 and 1 full turn.

MIL-S 46163A (section 1.2.2) specifies primer F as the surface primer-cleaner to be used with the nine compounds described in the document. MIL-S 46163A does not mention either of the primer grades, "N" or "T," specified by MIL-S-22473E. MIL-S 46163A section 6.9.1 alludes to primer's activating function with LLCs on inactive metals in the following statements (although the terms "activation" or "activator" are never used): "Primers for inert surfaces," [i.e., grade F] are required for surfaces "such as zinc, cadmium, and gold platings" ... "in order to meet the curing rate requirement of 3.5.2." Section 3.5.2 of MIL-S 46163A says, "The primer used in conjunction with Types I, II and III compounds on cadmium and zinc-plated surfaces shall be compatible to the compounds and shall provide a breakaway and prevailing torque of not less than 50 percent of the minimum specified in Table III after 15 minutes; and not less than 100 percent of the minimum specified in Table III after 4 hours when tested as specified in 4.6.3.2."

MIL-S 46163A, section 4.6.3.2, states that the compound is to be applied "...to the threads of BOTH [emphasis added] the nut and bolt..."

In correspondence with Henkel/Loctite® Company's North American Engineering Center (Mike Smigel, Henkel/Loctite®, to Brian Jensen, NESC, 16 Nov 2006) we learned that primer Grade "F" was never tested and certified to MIL-S-46163A. Further, Primer Grade F was removed

	NASA Engineering and Safety Center Technical Assessment Report	Document #: NESC-RP-04-092	Version: 1.0
Title: Evaluate the Performance of Loctite® as a Secondary Locking Feature for ISS Fasteners		Page #: 175 of 205	

from the market in June, 1995 and primer Grade N (Loctite® product number 7649) was recommended in its place. Further, Henkel/Loctite® has said that, “[primer N] 7649 is also not tested and certified to [MIL-S-46163A] although it generally meets the requirements. 7649 is tested to MIL-S-22473E Grade N Form R for existing designs and primers meeting this mil spec could be used with the adhesive/sealants that meet MIL-S-46163A.” Henkel/Loctite® continues, “Often Locquic Primer [grades] N [product 7649] & T [product 7471] are used interchangeably, with the only major difference being there on part life after drying on a part, prior to assembly. [Grade] N is one month and T is one week.” This information from Henkel/Loctite® Co. confirmed Primer N or Primer T could be used with the adhesive/sealants that meet MIL-S-46163A. Thus Primer T (Loctite® product 7471), the activator used in the tests conducted by this NESC, meets the specifications of MIL-S-22473E and is compatible with the liquid locking compounds described in MIL-S-46163A.

ASTM D5363-03 “Standard Specification for Anaerobic Single-Component Adhesives (AN)” (dated Dec. 2003, and corrected Aug 2006); states that it is intended to replace both MIL-S-22473E and MIL-S-46163A.

ASTM D5363-03 covers both the primer/activators mentioned in MIL-S-22473E including Grade “T” as used in the tests conducted by this NESC (It refers to them only as “primers” however), and it also covers both of the liquid locking compounds used in the tests conducted by this NESC.

ASTM D5363-03 specifies three groups of anaerobic adhesives. Group 01 includes “slow curing” LLCs with “Newtonian flow properties (viscosity is constant over a range of strain rates). The Group 01 locking compounds are identical with those 15 compounds covered in MIL-S-22473E. Torque strength standards for group 01 LLCs were set using 3/8” UNF 24TPI Grade 2 bolts. The torque strength standards and viscosities between the two documents are exactly alike. Group 02 are fast curing LLCs with Newtonian flow properties – this group includes Loctite® product 271 (group 02, class 2, grade 1, color red). The Group 02 locking compounds are similar to LLCs of Type I (Grades J, K, L) and Type III (Grades P, Q, R) in MIL-S 46163A. Similar, but the torque strength standards and viscosities between the two documents are not the same (if often close). Group 03 are fast curing, lubricating LLCs with “thixotropic flow properties (they thin when subjected to strains greater than the yield strain and regain thickness after rest) – Loctite® product 242 is included in this group (group 03, class 2, grade 1, color blue). The Group 03 locking compounds are what is referred to in MIL-S 46163A as “Type II” LLCs (Grades M, N, O). Torque standards for both groups 02 and 03 LLCs were set using 3/8” UNC 16TPI Grade 5 bolts.

ASTM D5363-03 mentions Primers [sic] Grade N and T (but not Grade F). Like the two MIL-Specs it replaces, this ASTM document mentions Aluminum Alloy 2024, Brass, Steel, and Plating, both Cadmium & Zinc; and also like them it does NOT mention stainless steel or titanium as materials for LLCs.

	NASA Engineering and Safety Center Technical Assessment Report	Document #: NESC-RP-04-092	Version: 1.0
Title: Evaluate the Performance of Loctite® as a Secondary Locking Feature for ISS Fasteners		Page #: 176 of 205	

ASTM D5363-03 defines "...breakaway torque as the initial torque required to break the bond, measured at the first movement between the nut and the bolt, when unscrewing an unseated assembly." Prevailing torque is defined as torque measured at 180° rotation of the nut. "However, for purposes of this specification, the definition of prevailing torque as the average of the four torques measured at 90, 180, 270, and 360° rotation of the nut is also acceptable." ASTM D5363-03, sections 7.5.1.1-4, specifies LLC application as follows: "Screw the nut onto the bolt such that 0.5 to 0.5625 in. (12.7 to 14.3 mm) of the threaded end protrudes. Apply sufficient adhesive to the bolt to completely cover the protruding threads of the bolt. Unscrew the nut over the adhesive until the end of the nut is flush with the end of the bolt. 7.5.1.4 Screw the nut back until 0.125 to 0.1875 in. (3.2 to 4.8 mm) of threads protrude to ensure complete coverage of the adhesive in the engaged area." Thus both male and female threads are coated with LLC, but it is applied only to the male thread.

ASTM D5363-03 specifies "percent of strength" after cure for each of the primers N & T in the document's Table 3. Primed zinc or cadmium plated (i.e., inactive metal) fasteners using Grade N (Loctite® 7649) primer, should yield prevailing torque of not less than 50 percent strength at standard conditions after 6 hours; and not less than 100 percent after 24 hours. Using Grade T (Loctite® 7471) primer on inactive metal, should yield strength at standard conditions of not less than 50 percent after 30 minutes; and not less than 100 percent after 2 hours, according to Table 3. Strength at standard conditions, measured as both breakaway and prevailing torque, -- on plated or inactive metal, using Loctite® 271 (group 02, class 2, grade 1, red LLC) -- is 16.9 - 39.5 N-m (150 - 350 inch-pounds), and 4.5-56.5 N-m (40-500 inch-pounds), respectively. Using Loctite® 242 (group 03, class 2, grade 1, blue LLC) strength at standard conditions is 1.1 - 22.6 N-m (10 - 200 inch-pounds), and 0.6-22.6 N-m (5-200 inch-pounds), respectively.

H.2 Inconsistencies of describing Primer/Activator in Standards Documents

These three main specification documents (MIL-S-22473E, MIL-S-46163A, & ASTM D5363-03) for using primer/activators are mainly clear and complete. However, as shown below, there are some lapses and some conflicting directions/conclusions among the several specs, and between them and Henkel/Loctite® Co., a major LLC manufacturer.

Cure Time and the Two Primer/Activators

MIL-S-22473E specifies either surface primer Grade T (Primer, "Quick," Yellow or Green, Loctite® product 7471) or surface primer Grade N (Primer, "Normal," Green, Loctite® product 7649) for MIL-S-22473 LLCs. MIL-S-22473E does not mention stainless steel or TITANIUM as materials for liquid locking compounds (LLCs). It does mention Aluminum Alloy 2024, Brass, Steel, as well as Zinc and Cadmium Plating. This document implied that primer could be used as a cleaner and will insure a cure on plated metals. However the impression is left that Grade T somehow affects a "quick" cure.

	NASA Engineering and Safety Center Technical Assessment Report	Document #: NESC-RP-04-092	Version: 1.0
Title: Evaluate the Performance of Loctite® as a Secondary Locking Feature for ISS Fasteners			Page #: 177 of 205

ASTM D5363-03 specifies prevailing torque for both primers N & T in the document’s Table 3. This document declares that “Primer T” is faster curing for inactive metal fasteners, “Primed zinc or cadmium plated (i.e., inactive metal) fasteners using Grade N (Loctite® 7649) primer, should yield prevailing torque of not less than 50 percent strength at standard conditions after 6 hours; and not less than 100 percent after 24 hours. Using Grade T (Loctite® 7471) primer on inactive metal, should yield strength at standard conditions of not less than 50 percent after 30 minutes; and not less than 100 percent after 2 hours, according to Table 3. Torque standards for groups 02 and 03 LLCs were set using 3/8” UNC 16TPI Grade 5 bolts.

MIL-S-46163A specifies “Grade F Primer-Normal compound, green color;” for MIL-S46163 LLCs. Its section 6.3 further specifies Grade F primer should be used when LLC is applied below 40°F. MIL-S46163 does NOT mention stainless steel or titanium as materials for LLCs. It does mention Aluminum Alloy 2024, Brass, Steel, and Plating, both Cadmium & Zinc.

In NESC correspondence with Henkel/Loctite® USA, the company states that primer/activator T will not necessarily create a faster cure than activator N on inactive metals. The correspondence stated that the ONLY consistent difference between the two activators is the on-part shelf life (T is 7 days and N is 30 days).

Primer/Activators and Inactive Metals

NESC correspondence with Henkel/Loctite® USA revealed, “Primer’s function on inactive metals like stainless steel is different [from “active” metals] in the sense that it ensures full cure in 24 hours. If no primer is used on inactive metals like stainless, most of the threadlockers will take significantly longer to fully cure and the timeframe is highly unpredictable. It could take 2-3 weeks to fully cure without a primer. The real question becomes ...when do you want to put the parts back in service? In further correspondence Henkel/Loctite® said, “One of the main functions of the primer [sic.] is to ensure full cure in 24 hours at room temperature. The primer puts a layer of metal ions down on the part to accelerate the cure on "inactive metals" which include some materials (e.g., stainless steel and titanium) and any protective coating such as in platings, anodized aluminum and galvanized steel. The threadlockers cure in the absence of air and metal ions are a catalyst in curing them. [Loquic] 7649 contains copper salt & [Loquic] 7471 contains an amine and these serve that function. Further questions to Henkel/Loctite® regarding the LLCs behavior in stainless steel after full 24 hour cure is more ambiguous. When asked if Loctite® 242 or 271 actually bond (“adhere”) to the stainless steel threads or if the LLCs “cohere” when cured to fill the voids, but do not bond to the metal, the answer was, ”...in essence the threadlockers perform both functions, filling the voids and also providing adhesion to the metal.” But they would not venture an opinion on the relative contributions of the different locking mechanisms in this application.

As noted, MIL-S 46163A specifies primer F as a surface primer-cleaner. MIL-S 46163A (section 6.9.1) describes that “Primers for inert surfaces,” (i.e., grade F) are REQUIRED

	NASA Engineering and Safety Center Technical Assessment Report	Document #: NESC-RP-04-092	Version: 1.0
Title: Evaluate the Performance of Loctite® as a Secondary Locking Feature for ISS Fasteners		Page #: 178 of 205	

[emphasis added] for surfaces “such as zinc, cadmium, and gold platings” Correspondence with Henkel/Loctite® USA ascertained that Primer F has been replaced by Primer N, and further that Primers N and T may be used interchangeably to cause LLCs to cure within 24 hours on stainless steel fasteners.

ASTM D5363-03 mentions “Primers” [sic] Grade N and T, but not Grade F. Like the two MIL-S it replaces, this ASTM document mentions Aluminum Alloy 2024, Brass, Steel, and Plated fasteners, both Cadmium & Zinc; and also like them it does NOT mention stainless steel or titanium as materials for LLCs, or to refer to the primers as “activators.”

Application of LLC

MIL-S 22473 is vague in its application instructions. MIL-S 46163A instructs the user to apply LLC to both nut and bolt. ASTM D5363-03 directs the user to apply LLC to the bolt only.

	NASA Engineering and Safety Center Technical Assessment Report	Document #:	Version:
		NESC-RP-04-092	1.0
Title: Evaluate the Performance of Loctite® as a Secondary Locking Feature for ISS Fasteners			Page #: 179 of 205

Appendix I. Loctite® Application Process Comparison

This appendix describes aspects of the preparation and application of LLC's for five ISS manufacturing sites. The standards listed below were reviewed relative to their use for the application of LLCs to flight hardware. The review included; (1) how activator/primer is described in the documents, (2) a comparison of the documents, (3) how LLC's are described in the documents, and, (4) results of field observations of applying Loctite® during ISS rework operations.

- 1. Boeing Document BAC 5011, "Application of Retaining Compounds" (Dec-86)**
- 2. Boeing Document Dwg. 683-13000 "Hatch Assembly" (May, 2005)**
- 3. Lockheed Martin (Michoud Oprs) Document STP 2009B, "Locking and Sealing Compounds, Application of" (Sep-04)**
- 4. Rockwell Document MA0106-333, "Application of Locking and Retaining Compound to Threaded Electrical, Hardware and Mechanical Fasteners" (Dec-85)**
- 5. Boeing Huntington Beach Document MA0106-333, "Application of Locking and Retaining Compound to Threaded Electrical, Hardware and Mechanical Fasteners" (Apr-04)**

How Primer/Activator is described in ISS Manufacturing Documents

A sample of ISS contractors' process and procedures documents for using primer/activators are mainly clear and complete. However there are some lapses and some conflicting directions/conclusions among the several contractors, and between them and Henkel/Loctite® Co.

Boeing Document BAC 5011, "Application of Retaining Compounds" (Dec-86) states: Use MIL-S-22473 Grade T primer for MIL-S-22473 compounds; and MIL-S-46163 Grade F primer/activators for MIL-S-46163 compounds. "Coat surface with Primer/Activator prior to application of locking compound." "Air dry primer/activator for 5 min minimum..." "Primed parts could be stored in poly bags up to 24 hours" [NOTE: Grade F primer/activator – Not produced or available for purchase -- is called for when using MIL-S-46163 LLCs, in this still current guidance document. Also note the use of the term "primer/activator" to denote the activation required for reliable cure of LLC on inactive metals

	NASA Engineering and Safety Center Technical Assessment Report	Document #: NESC-RP-04-092	Version: 1.0
Title: Evaluate the Performance of Loctite® as a Secondary Locking Feature for ISS Fasteners			Page #: 180 of 205

Boeing Document Dwg. 683-13000 “Hatch Assembly” (May, 2005). Although this document parallels BAC 5011, it represents a specific application of the guidance of the latter. This does not specifically mention “primer” or “cleaner” or “activator.”

Lockheed Martin (Michoud Oprs) Document STP 2009B, “Locking and Sealing Compounds, Application of” (Sep-04), states, Grade T (quick) and N (normal)...surface primer activators (meeting curing rate specified in MIL-S-22473) are required for ...plated surfaces..., chemical conversion coat[ings], passivated surfaces..." "...primer shall completely coat the area to be coated by compound...shall completely cover the junction where the bolt threads protrude through the nut. [NOTE: different cure times for LLC prepared using primer/activators "T" and "N" are stated in Table V, (and labeled “Quick” and “Normal” respectively) -- but are NOT restricted to "active" metals only. This suggests that grade T primer/activator provides a quick cure in all applications].

Rockwell Document MA0106-333, “Application of Locking and Retaining Compound to Threaded Electrical, Hardware and Mechanical Fasteners” (Dec-85) states, MIL-S-22473 Grade T primer [sic] shall be used with any MIL-S-22473 LLC in this document. "[Grade T] primer shall be omitted on titanium hardware." [NOTE: titanium fasteners are stated by Henkel/Loctite® to require activator to ensure LLC cure in 24 hours]. "Apply Grade T onto external and internal threads..." Clean up excess primer with cloth & Trichloroethane. Allow to dry 15 min minimum. May be kept 5 days in plastic bag. Curing the LLC is stated as, “Minimum 3 hours. May be handled after 30 min, but shall not be stressed until full cured.” [NOTE that this short cure time suggests grade T primer provides a quick cure on all materials].

Boeing Huntington Beach Document MA0106-333, “Application of Locking and Retaining Compound to Threaded Electrical, Hardware and Mechanical Fasteners” (Apr-04) [NOTE the document number is the same as the Rockwell document above, but is of much later date] states, Primers [sic] are used to cure LLC on inactive surfaces. Primer should be used on all surfaces to be treated with LLC. Primer N has an on-part life of 30 days. Primer T's on-part life is 7 days. Both primers result in equal strength bond. Apply primers to internal and external threads of fastening system, and prevent application on other surfaces. Apply a thin film, do not "puddle." Allow to dry for 15 min. [NOTE: Although it omits the term “activator,” this contractor’s description of the purpose and application of primers/activators N and T are otherwise consistent with what Henkel/Loctite® USA has described for LLCs on inactive metals]. Cleaning before LLC application is as follows, “Both internal and external threads of the fastening system shall be cleaned with acetone or MEK...”

	NASA Engineering and Safety Center Technical Assessment Report	Document #: NESC-RP-04-092	Version: 1.0
Title: Evaluate the Performance of Loctite® as a Secondary Locking Feature for ISS Fasteners		Page #: 181 of 205	

I.2 Comparison among the Five Application Procedure Documents

This comparison shows a variety of implied definitions of primers as cleaners, as cure accelerators, or as necessary for reliable cure on inactive metals in 24 hours. The five documents also call for differing and various types of LLCs without background or reasons for the choice. Differences in LLC cure times are also evident among the documents. There are three unique deviations in individual documents including statements that primer is not required before LLC application on titanium; that LLCs are not used on flight fasteners larger than 1/4" diameter; and that LLCs could be applied over dry film lubricant.

How LLC is described in ISS Manufacturing Documents

Boeing Document BAC 5011, "Application of Retaining Compounds" (Dec-86)

This document states: "Locking surfaces [note plural] shall be covered with retaining compound, as evidenced by a continuous fillet visible at the parting line of the assembled joint. Remove excess material." Cure LLC "...72 hours @ 40°F to 70°F. 1 hour @ 70°F and above. "Do not subject joined parts to handling, vibration or shock until cured." [Note: The range in cure times does not coincide with Henkel/Loctite®'s opinion that LLC will achieve full cure in 24 hours on stainless steel if primer/activator is used first]. Cleaning materials or methods are not described.

Boeing Document Dwg. 683-13000 "Hatch Assembly" (May, 2005)

Although this document parallels BAC 5011, it represents a specific application of the guidance of the latter. This document incorporates specific language for the task as follows: "Thread lock adhesive shall be applied to jam nut/tension rod threads. (Ref BAC 5011 for Boeing internal use). Thread lock adhesive per MIL-S-22473, Grade HV, Brown, shall be used." [NOTE that in accordance with BAC 5011, the LLC is to be applied to the rod and nut threads, plural]. The LLCs are called out as follows: "... optional thread lock adhesive allowable: MIL-46163A Type II Grade M, (Loctite® 222MS, Preferred option), MIL-46163A, Type II Grade N (Loctite® 242), MIL-S-22473E, Grade AV (Rite-Lok TL-71) [red color, similar performance specifications to Loctite® 271], Loctite® 246."

Lockheed Martin (Michoud Oprs) Document STP 2009B, "Locking and Sealing Compounds, Application of" (Sep-04), calls out the LLCs as follows:

MIL-S-22473 Grades A,H,EV,C,AV,CV,E,AA,B,D,HV & Loctite® Grade 294 [wicking type, not referenced in MIL-S-22473]. Specific LLC application procedures are described only for Loctite® product 294 (wicking type). "Using a clean wiping cloth wipe off excess compound after it has remained on the interface between the bolt and nut for a minimum of 24 hours." "If ... handled after application and before cure, they shall be handled in a manner so that there is no relative motion between mating surfaces. Cure time is specified as "2 hours cure with Primer T; 6 hours cure with Primer N, [NOTE that the use for inactive metals is not described]. Cleaning materials and methods are as follows, "Contamination and grease shall be removed...by vapor degreasing or

	NASA Engineering and Safety Center Technical Assessment Report	Document #: NESC-RP-04-092	Version: 1.0
Title: Evaluate the Performance of Loctite® as a Secondary Locking Feature for ISS Fasteners			Page #: 182 of 205

by use of [MEK]." "The applied compound shall be smooth, homogeneous, and free of lumps, abrasives, and other contamination."

Rockwell Document MA0106-333, “Application of Locking and Retaining Compound to Threaded Electrical, Hardware and Mechanical Fasteners” (Dec-85) says that the LLCs are “...used as auxiliary retaining method for mechanical fasteners.” The document calls for MIL-S-22473 Grades A (red 100-250 in lbs), C (blue 40-100 in lbs), N [sic] (brown, 10-25 in lb). [NOTE, Brown sealant is Grade "H." GRADE "N" IN 22473 REFERS TO "Normal" PRIMER]. Cleaning parts is stated as, "...shall be cleaned by solvent wiping per MA0110-303." (formerly called for Trichloroethane -- MEK for titanium -- per MA0110-303). LLC application procedure is stated as follows: "...applied to BOTH [emphasis added] mating threads by camel hair brush or by nozzle-equipped containers. Use only as much compound as is needed to fill the space between the mating surfaces. Remove excess compound by wiping with a clean cloth wet with trichloroethane." Do not coat adjacent areas, apply only to threads. Verification of torque value shall be completed within 5 min elapsed time from application. Curing is stated as, “Minimum 3 hours. May be handled after 30 min, but shall not be stressed until full cured.”

Boeing Huntington Beach Document MA0106-333, “Application of Locking and Retaining Compound to Threaded Electrical, Hardware and Mechanical Fasteners” (Apr-04) [As noted above, this document’s number is the same as the Rockwell document, but a much later date]. It describes cleaning before LLC application as follows, “Both internal and external threads of the fastening system shall be cleaned with acetone or MEK...” Regarding LLC, this document limits their use to “flight hardware of ¼” diameter and smaller.” Further, "Usage is acceptable with ... moly disulfide dry film lubricant.” [NOTE: This use is in contrast with the Henkel/Loctite® opinion]. The document refers to "liquid locking compounds (LLC)." It calls out LLCs only from the following: MIL-S-22473 Grade A, Red, for 100-250 In.-Lb Torque with 3/8-inch fastener; Grade C, Blue, 40-100 In.-Lb Torque with 3/8" fastener; Grade H, Brown, 10-25-inch-lb torque with 3/8-inch fastener. Grade H used for 0.250 inch-0.190 inch fasteners; Grade JV used for 0.164 inch-0.112 inch diameter fasteners. The application procedure is quite detailed and consistent with Henkel/Loctite® guidance: "Sealant shall be applied to both internal and external thread, except when female is thru hole in FOD critical application. For 0.250 inch and smaller fasteners, two drops of sealant shall be applied 180 degrees apart. It will cover a minimum of 90 percent of the threads. Excess sealant is removed using acetone or MEK. Processes shall be qualified for each combination of materials used prior to acceptance of the first production part." The only mention of LLC curing were two statements, “Caution, LLC will cure in a vacuum” and “Final torque must be achieved within 5 minutes of application,” (which suggested LLCs will cure quickly).

	NASA Engineering and Safety Center Technical Assessment Report	Document #: NESC-RP-04-092	Version: 1.0
Title: Evaluate the Performance of Loctite® as a Secondary Locking Feature for ISS Fasteners		Page #: 183 of 205	

I.3 Results of Field Observation

A technician, who was applying Loctite® at one of NASA's vendor facilities performing rework on the ISS, was observed as part of field work to provide information to the NESC. This technician's supervising engineer verified that the technician had received classroom training before performing the rework operation using Loctite® on stainless steel fasteners. As requested, the technician performed a simulation of that portion of the rework operation, in which Loctite® liquid locking compound was applied to a stainless steel 3/8 x 24 threads per inch bolt and nut assembly. The technician did not apply the primer/activator during this demonstration and, when questioned about this omission, the technician explained that acetone (a major ingredient in primer/activator 7471) was usually used in the rework operation to remove residual cured Loctite®. The technician assumed because the demonstration bolt and nut were new, that the use of the "cleaner/primer" was not required. The technician used Loctite® 242 (one of several approved LLCs) in the rework drawing. Although, the LLC was only applied to the threads on the sample bolt and not to the nut (per BAC 5011, and the rework drawing), the application on bolt only was consistent with the actual threaded part – on which the nut remained captive during the rework process. This observed demonstration was consistent with the effects of incomplete explanation/understanding of the real purpose of using primer/activator to cure the LLC (in a threaded fastener made from inactive metal). In addition, the possibly ambiguous instructions existed in the rework drawing, to apply LLC to nut/tension rod threads.

	NASA Engineering and Safety Center Technical Assessment Report	Document #: NESC-RP-04-092	Version: 1.0
Title: Evaluate the Performance of Loctite® as a Secondary Locking Feature for ISS Fasteners			Page #: 184 of 205

Appendix J. Literature Review of the Self-Locking of Threaded Fasteners

J.1 Introduction

This literature review provides an overview on the self-loosening of threaded fasteners, which specifically includes bolted joints. Initially, a brief chronological overview of research reports related to the self-loosening of fasteners due to vibration is provided. Then a summary of parameters that have been identified by the authors of the research articles are summarized and followed by a section which presents a brief overview of some testing machines that have been used. This literature review is organized to be only a review of the topic, and details on any of the testing and research that was conducted may be found in the original articles that are identified in the reference section.

J.2 Overview

Threaded fasteners have been in use by designers and engineers for many years. The reason is that they provide a simple and proven solution for assembling multiple parts together in an efficient and effective manner.⁴ Creating a one-piece structure capable of providing the same functionality as a given assembly would be impossible in some cases, as well as impractical in many others situations.⁵

Although the use of threaded fasteners provides benefits and design options to a designer, there are environmental conditions that can have an adverse effect on the design. When a designer purchases and uses a threaded fastener, it is often for, “the clamping force provided by the action of the fastener and tapped hole, or the fastener and a nut.”⁶ However, preload in the fastener can be eliminated by the mechanism of vibration loosening,⁷ which in some situations can actually result in the fastener being totally removed from the assembly.⁸

Many researchers have conducted experiments with the goal of identifying parameters of threaded fastener design that contribute to the self-loosening of the joints. They have been trying to identify why fastener loosening can unintentionally occur as a result of operational conditions.⁹

⁴ Anon 16

⁵ Anon 16

⁶ Anon 16

⁷ Bickford An Introduction 60

⁸ Anon 18

⁹ Bolt Science

	NASA Engineering and Safety Center Technical Assessment Report	Document #: NESC-RP-04-092	Version: 1.0
Title: Evaluate the Performance of Loctite® as a Secondary Locking Feature for ISS Fasteners			Page #: 185 of 205

Nevertheless, “in spite of numerous advances in fastener design, materials and techniques, the problem of fastener loosening is all too prevalent.”¹⁰ Additionally, even though the phenomenon of unintentional vibrational loosening is accepted by many as a real issue, it is widely misunderstood by many Engineers.¹¹ As summarized by Ramey and Jenkins,

“The threaded fastener, or bolt, is one of the most common connecting devices. Used in a wide range of applications, one would expect that the knowledge of how a bolt performs under certain loading conditions would be well known. While the behavior of bolts under static tensile and shear forces is fairly well understood, their behavior under dynamic loads, such as vibration, is not.”¹²

Threadlocking devices are one solution to the problem of threaded fastener loosening. There are many devices available and the American National Standards Institute (ANSI) Subcommittee B18:20 identified three basic locking fastener categories: free spinning, friction locking and chemical locking.¹³ This literature review will only cover the chemical locking category, which includes anaerobic adhesives that fill and bond gaps between the male and female threads.¹⁴

J.3 Chronology

Since the issue of self-loosening of bolted joints has been around for decades, there are numerous reports and studies that have been conducted that reflect progress with respect to a better understanding of the topic. Adapted from a survey or review of work on dynamic loosening by Hess, the following chronology is a brief summary of published work on self-loosening of threaded fasteners. This review is intended only as an overview of the published knowledge on this topic. See original sources if more detailed information is needed.

1945 Goodier and Sweeney started from the idea that “loosening would be a consequence of mere fluctuation, not necessarily rapid, of bolt tension, formed a theory of the mechanism of loosening, and carried out an experimental investigation of it in ordinary tensile test machines.”¹⁵

1950 Sauer, Lemmon, and Lynn conducted “experimental tests that examined the effect of alternating cycles of axial loading, dynamic to static load ratio, contact surface condition, and misalignment on loosening of threaded components.”¹⁶

¹⁰ Anon 16

¹¹ Bolt Science

¹² Ramey and Jenkins 1

¹³ Bolt Science

¹⁴ Bolt Science

¹⁵ Goodier and Sweeney 789

¹⁶ Hess in Bickford

	NASA Engineering and Safety Center Technical Assessment Report	Document #: NESC-RP-04-092	Version: 1.0
Title: Evaluate the Performance of Loctite® as a Secondary Locking Feature for ISS Fasteners		Page #: 186 of 205	

1966 Clark and Cook “investigated the effect of fluctuating torque on loosening of a tightly sealed bolt. They pointed out that while it is true, in many machine situations, that fluctuating tension remains the primary component of load on the bolt, there are also many situations in which two mating parts held by a bolt rotate a minute amount with respect to one another.”¹⁷ “The results of the tests show that bolt loosening is a function of both oscillatory torque amplitude and initial shank stress.”¹⁸ Specifically, “as the amplitude of the oscillatory torque is reduced, a larger number of cycles are required for bolt loosening, until eventually the bolt will apparently endure a certain level of fluctuating torque indefinitely. This finding led them to the conclusion that “accidental overloads contribute more to bolt loosening than do continuous repetitive oscillatory torques of small amplitude.”¹⁹

1966 The Elastic Stop Nut Corporation of America (ESNA) conducted testing that “resulted in the first theory on shock-induced loosening.” “The theory is based on the idea that shocks or impacts to a bolted assembly will cause the components to resonate and loosen.”²⁰ “Test data from experiments show that the number of impacts and the severity of the impacts are the two variables that promote loosening failure. Frequency of the impact was not found to have an effect, except that a certain number of blows can be struck in less time if the frequency is raised.”²¹ “The fixture ESNA used for their experiments is described in MIL-STD-1312-7A.”²²

1968 Gambrell presented “a series of experiments to examine how loosening is influenced by bolt thread series (coarse or fine), initial preload, lubrication, dynamic/static load ratio (DSR), frequency of loading, and number of cycles of load application.”²³ The “axial cyclic tension was applied to the test joint by a variable-speed electric motor driving a cam and follower that activates a load lever.”²⁴

1969 Junker discussed the self-loosening of preloaded bolted connections when subjected to vibration. Specifically, he presented a new machine design that yielded quantitative data for evaluating locking properties.²⁵ He proposed a unique test method and apparatus to make it possible to reproduce conditions of vibration that are not only certain to loosen bolted joints, but which also closely simulate actual assembly conditions. He showed that preloaded fasteners can

¹⁷ Hess in Bickford 762

¹⁸ Hess in Bickford 764

¹⁹ Hess in Bickford 764

²⁰ Hess in Bickford 765

²¹ Hess in Bickford 766

²² Hess in Bickford 766

²³ Hess in Bickford 767

²⁴ Hess in Bickford 767

²⁵ Junker 1969 314

	NASA Engineering and Safety Center Technical Assessment Report	Document #:	Version:
		NESC-RP-04-092	1.0
Title:		Page #:	
Evaluate the Performance of Loctite® as a Secondary Locking Feature for ISS Fasteners		187 of 205	

loosen as a result of rotation, as soon as relative motion occurs between the mating threads and between the bearing surfaces of the fastener and the clamped material.²⁶

1970 Koga “studied the loosening of threaded fasteners subjected to repeated impacts and he performed experiments, as well as developed a theory of loosening based on the theory of propagation of stress waves.”²⁷ “Koga qualitatively showed that changing the angle of the thread and other details on the screw end could alter the amount of tensile waves propagated.”²⁸

1973 Koga “used three-dimensional analytical geometry to quantitatively show the effect of thread angle on loosening of bolted joints.”²⁹

1972 Finkelston of Standard Pressed Steel Co. (SPS), provided some suggestions for increasing vibration resistance to loosening, even though some identified are possibly uneconomical for designs that are optimized for weight and size. The suggestions were to “increase grip friction in the bolt by increasing preload or the number of bolts in the joint, eliminate relative motion in the joint by designing rigid members with little or no clearance, and to use fasteners that have high resistance to loosening.”³⁰ His experiments were performed on a Junker type machine.

1973 Walker “was the first to use fractional factorial experiments design concepts to investigate the influence of several variables or factors on the vibration life of fasteners.” “The factors evaluated were preload, prevailing torque, thread pitch, surface coating, and thread pitch diameter clearance.”³¹ Walker performed tests with two different machines: a Junker machine and the apparatus described in MIL-STD-1312-7A, in addition, the results from tests on both machines were reported to be in good agreement.³²

1973 Junker stated that, “preloaded screws (or nuts) rotate loose, as soon as a relative motion in the thread takes place” and identified that this motion cancels the friction grip and originates an inner off-torque proportional to the thread pitch and to the preload. Additionally, the inner off-torque rotates the screw loose if the friction under nut or bolt head bearing surface is cancelled by relative motions.³³

²⁶ Junker 1969 314

²⁷ Hess in Bickford 773

²⁸ Hess in Bickford 774

²⁹ Hess in Bickford 774

³⁰ Hess in Bickford 774

³¹ Hess in Bickford 776

³² Hess in Bickford 776

³³ Junker Feb 1973 (final) 23

	NASA Engineering and Safety Center Technical Assessment Report	Document #: NESC-RP-04-092	Version: 1.0
Title: Evaluate the Performance of Loctite® as a Secondary Locking Feature for ISS Fasteners		Page #: 188 of 205	

1973 Pearce gave a preview of locking fastener types, benefits, and problems. Specifically, he identified and categorized free spinning fasteners, friction locking fasteners, and chemical locking fasteners, of which he advocated for the chemical locking type to be the best option for preventing fasteners from loosening due to vibration.³⁴

1974 Hardiman discussed the use of anaerobic adhesives for converting threaded fasteners to a locking fastener system. He claimed that anaerobic adhesives could develop sufficient locking torques for a wide range of surface conditions and in his paper he provided a general overview of what anaerobic adhesives are, how they work, and advantages for using them in design.³⁵

1978 Sakai “performed a series of theoretical analysis and experiments on bolted assemblies.”³⁶

1979 Sakai “investigated the loosening of bolts tightened over their yield point and subjected to tensile load.” He presented a theoretical analysis, along with static and dynamic experiments that were reported, and he concluded that “tightening bolts over their yield point has no disadvantage” with respect to loosening. Additionally, “it was found that the fatigue life of bolts tightened over their yield point was longer than that of bolts tightened in elastic range.” The reason for this finding was assumed to be attributed to having a larger clamping force resulting in a smaller load on the bolt, which corresponds to a longer fatigue life.³⁷

1980 Kerley discusses issues encountered with bolted connections, including the effects of bolt tightening methods on structure stresses, verification of axial preload procedures, design considerations for shear loaded joints, locking features, and failure analysis.³⁸

1981 Haviland identified ten myths, or fables, he found throughout literature, or in designers minds, and provided the facts about each. He presented these with the objective of assisting with the achievement of better understanding development of predictable clamp load, prevention of self-loosening, and maintenance of the ability to disassemble the joint by avoiding galling and corrosion.³⁹

1982 Kerley believed that time-related failures were strictly an engineering problem that could be avoided with good design. Therefore, he presented an overview of the concept of bolt

³⁴ Pearce 1-4

³⁵ Hardiman 1

³⁶ Hess in Bickford 776

³⁷ Hess in Bickford 779-780

³⁸ Kerley Nuts and Bolts 1980

³⁹ Haviland 1

	NASA Engineering and Safety Center Technical Assessment Report	Document #: NESC-RP-04-092	Version: 1.0
Title: Evaluate the Performance of Loctite® as a Secondary Locking Feature for ISS Fasteners		Page #: 189 of 205	

analysis with the intent for designers to use the existing analytical and testing methods to help prevent failures.⁴⁰

1983 Haviland proposed that the limitations of fasteners are not always well understood and therefore looked at how a screw fastener generally works, and how to make it more reliable as well as cost effective in use. He reviewed clamping force, choosing a correct bolt, selection of a safe design load level, loosening tendencies, how to keep the joint tight, testing with transverse shock, and prevention of premature loosening.⁴¹

1983 Bickford stated that, “the behavior of a joint in use depends on the preload in the bolts in use, not the preload introduced by the mechanic.” He continued that getting the correct initial preload in a bolted joint is very difficult to do and that if torque is being used to tighten the fasteners, for example, there are some 76 variables that affect the relationship between achieving the desired preload.⁴² Additionally, he identified another mechanism that can eliminate all initial preload in a fastener and is known as vibration loosening, under which the fastener first loses preload gradually for some time. However, once the residual preload in the fastener has fallen so far that it is no longer able to prevent transverse slip between male and female threads, or nut and joint surfaces, then the loosening action becomes far more rapid and can result in total loss of the nut.⁴³

1983 The American Society of Mechanical Engineers (ASME) and American National Standards Institute (ANSI) B-18 Subcommittee on the Loosening Mechanisms of Bolted Joints Under Vibration was formed in the early 1980’s. The subcommittee was active at least until 1987, until extended funding for the comprehensive research plan was not acquired and the members of the subcommittee disbanded.⁴⁴ Peter P. Zemanick was the chairman of the committee and James Kerley, of NASA GSFC, was also a member during the duration of the team. The subcommittee had a proposal for a comprehensive experiment plan to study (test and evaluation procedure) that would be used to study vibration loads in bolted joints, of which they were “trying to provide the first real understanding of the reasons fasteners loosened.”⁴⁵ Research by the subcommittee would have included analysis of finite-element and probabilistic models, as well as exploratory and milestone tests and the variables they wanted to test were to include: thread pitch, clearances, fit, length to diameter ratio, direction of vibration, frequency of vibration, and joint damping properties.⁴⁶ One of the specific goals and proposals of the research

⁴⁰ Kerley the use and miss use 1

⁴¹ Haviland 1983 16

⁴² Bickford That Initial Preload 57

⁴³ Bickford That Initial Preload 60

⁴⁴ Hess in Bickford 782

⁴⁵ Bickford Fastener Groups Seek Answers to Bolted-Joint Problems 80

⁴⁶ Bickford Fastener Groups Seek 80

	NASA Engineering and Safety Center Technical Assessment Report	Document #: NESC-RP-04-092	Version: 1.0
Title: Evaluate the Performance of Loctite® as a Secondary Locking Feature for ISS Fasteners			Page #: 190 of 205

plan was to identify mathematical relationships that govern loosening based on the study of simple joints, such as beams, and then apply them to the design of more complex structures.⁴⁷

1983 Light summarized a comprehensive nine-year study on vibration loosening of threaded fastenings performed by the British Aircraft Company and funded by the British Ministry of Defense. The study examines existing test equipment, develops models and analyses, and provides comparative test data using a Junker type test machine. Loctite® adhesives, Durlock bolts and Huckcrimp fasteners were found to perform the best of the dozens of locking features tested.

1984 Yamamoto and Kasei “proposed a new mechanism of self-loosening of bolt and nut joints subject to transverse vibration,” which “attributes self-loosening rotation of a nut to the accumulation and release of potential energy due to torsional bolt deformation.”⁴⁸ They developed quantitative models based on a two-stage theory for the nut to slide along the thread of the bolt, however, there were no quantitative results provided for model verification.⁴⁹

1984 Kerley conducted testing on Spiralock® nuts under vibration and static load conditions and found that, “the most severe vibration tests did not loosen the nuts when subjected to both high amplitude sine and random testing.”⁵⁰

1985 Charles reported that in order to improve the performance of threaded fasteners in conditions under vibration, adhesives could be used as a preventive option, and may also be considered perhaps the most simplest and easiest of all locking systems.⁵¹

1986 Haviland identified variables that affect the cure speed and initial strength of adhesives that are used as locking mechanisms.⁵²

1987 Kerley used an application of the method of retrodution to analyze the topic of self-loosening of bolted joints for why and how nuts back off during vibration.⁵³

1989 Vinogradov and Huang numerically investigated only one aspect of the problem of self-loosening of bolted joints, explicitly, the effect of frequency of vibrations.⁵⁴ They noted in their

⁴⁷ Pai and Hess 2003 Inf of Fastener 618

⁴⁸ Hess in Bickford 786

⁴⁹ Jiang, Zhang, and Lee A study 2003 518

⁵⁰ Kerley 3

⁵¹ Charles 165

⁵² Haviland 55

⁵³ Kerley NASA TM4001

⁵⁴ Vinogradov and Huang 136

	NASA Engineering and Safety Center Technical Assessment Report	Document #: NESC-RP-04-092	Version: 1.0
Title: Evaluate the Performance of Loctite® as a Secondary Locking Feature for ISS Fasteners			Page #: 191 of 205

conclusions that the inertial mechanism of self-loosening is triggered by the non-even distribution of the preload forces along the thread, and followed that joints with more even distribution of preload forces should be less susceptible to vibration loosening.⁵⁵

1990 Bickford provides an overview of how vibration loosens a nut, Junkers theory of vibration, testing option for simulated joint connections, and suggestions for how to resist vibration.⁵⁶

1992 Daadbin and Chow studied the loosening due to impact load using a mass-spring model and “it was argued that in the occurrence of resonance, the nut thread would separate from the thread of the bolt and the nut would undergo a free flight until it touched the inclined surface again.”⁵⁷ A series of experiments were conducted to verify the theory, however, the preload applied in the experiments was not realistic for the bolt sizes used in their experiments.⁵⁸

1995 The objective of the study by Ramey and Jenkins was to identify the main design parameters contributing to the loosening of bolts due to vibration and to identify their relative importance and degree of contribution to bolt loosening. The report stated that,

“Vibration testing was conducted on a shake table with a controlled-random input in the dynamic testing laboratory of the Structural Test Division of MSFC. Test specimens which contained one test bolt were vibrated for a fixed amount of time and a percentage of pre-load loss was measured. Each specimen tested implemented some combination of eleven design parameters as dictated by the design of experiment methodology employed. The eleven design parameters were: bolt size (diameter), lubrication on bolt, hole tolerance, initial pre-load, nut locking device, grip length, thread pitch, lubrication between mating materials, class of fit, joint configuration, and mass of configuration. These parameters were chosen for this experiment because they are believed to be the design parameters having the greatest impact on bolt loosening.”⁵⁹

The investigation results indicated that nut locking devices, joint configuration, fastener size, and mass of configuration were significant parameters in bolt loosening due to vibration.⁶⁰

1996 Hess and Davis reported on a series of experiments they conducted to examine the motions of threaded fasteners subjected to axial harmonic vibration. Particularly, a significant

⁵⁵ Vinogradov and Huang 137

⁵⁶ Bickford An Introduction 440-466

⁵⁷ Jiang, Zhang, and Lee 2003 A study 518

⁵⁸ Jiang, Zhang, and Lee 2003 A study 518

⁵⁹ Ramey and Jenkins i

⁶⁰ Ramey and Jenkins i

	NASA Engineering and Safety Center Technical Assessment Report	Document #: NESC-RP-04-092	Version: 1.0
Title: Evaluate the Performance of Loctite® as a Secondary Locking Feature for ISS Fasteners			Page #: 192 of 205

relative twisting motion is found to occur against and with the load, therefore indicating that the components can loosen or tighten due to vibration. The direction of twist was shown to depend on the frequency and amplitude of the vibratory input in addition to other physical parameters.⁶¹

1996 Hess, Basava, and Rasquinha examined fasteners subject to axial vibration and found that they can experience either loosening or tightening.⁶² Specifically, they studied the effect of vibration level and initial preload on the clamping force and concluded that, with high preloads and/or low vibration levels, the clamping force remains steady over a large number of cycles, however, as the preload decreases and/or the vibration level increases, first loosening then tightening of the assembly occurs.⁶³

1996 Johnson reported tests results that indicated a failure to maintain dimensional size conformance for standard fasteners can lead to degraded vibration resistance.⁶⁴

1997 Hess and Sudhirkashyap presented a dynamic model of a single-bolt assembly with moderate preload subjected to axial harmonic vibration and found that depending on the applied vibration amplitude and frequency, along with other system parameters such as preload, contact stiffness, mass of the clamped components, coefficient of friction and thread fit, can be tuned to make either loosening or tightening of the joint occur.⁶⁵

1998 Dong and Hess reported on the development of a test apparatus and procedure to evaluate threadlocking adhesive life when in an environment of accelerated vibration. They found an inverse power relationship that is present between the threadlocking adhesive life and the applied vibration level.⁶⁶

1998 Hess provided a chapter on vibration and shock –induced loosening in a bolting handbook. This work includes a survey of theoretical analysis and experimental work spanning over five decades, general design guidelines for minimizing fastener loosening, an overview of fastener locking techniques, and descriptions of test fixtures and test machines that have been used to assess fastener loosening under dynamic conditions.⁶⁷

1999 Dong and Hess presented the results from dynamic tests that investigate the effects of threaded dimensional conformance of fasteners on vibration induced loosening. The data show a

⁶¹ Hess and Davis 417

⁶² Hess, Basava, and Rasquinha 97

⁶³ Hess, Basava, and Rasquinha 101

⁶⁴ Hess in Bickford 806

⁶⁵ Hess and Sudhirkashyap 311

⁶⁶ Dong and Hess 816

⁶⁷ Hess in Bickford 757

	NASA Engineering and Safety Center Technical Assessment Report	Document #:	Version:
		NESC-RP-04-092	1.0
Title:		Page #:	
Evaluate the Performance of Loctite® as a Secondary Locking Feature for ISS Fasteners		193 of 205	

significantly degraded resistance to vibration for fastener combinations with undersized pitch and major bolt diameters, or oversized pitch and minor nut diameters, compared to fasteners within conformance.⁶⁸

2002 Pai and Hess used a three-dimensional finite element model to study details of four different loosening processes that are characterized by combinations of complete or localized slip at the head as well as thread contacts. Results of the finite element analysis show that it is possible to have loosening at relatively low shear loads (i.e., lower than previously expected) due to localized slip.⁶⁹

2003 Jiang, Zhang, and Lee studied both an experimental investigation and a finite element analysis to explore the mechanism of the early stage self-loosening of bolted joints under transverse cyclic loading.⁷⁰ The experimental and finite element simulations suggested that friction between the clamped plates had an insignificant influence on the early stage of bolt self-loosening when transverse displacement is a controlling factor.⁷¹ It has been widely known for many years that relaxation and embedment occurs in the early stages of loosening under dynamic loading.

2003 Pai and Hess identified that,

“Recently, new experimental and three-dimensional finite element analysis results have helped identify the minimum shear forces required to cause loosening and also understand details of the underlying mechanism of loosening. It was shown that in some cases, loosening in joints occurs due to localized slip when the fastener is subjected to a dynamic shear force about half the magnitude required to cause complete slip at the fastener bearing surface.”⁷²

The objective for this paper was to develop a procedure to identify regions in an assembly where the fastener would be least likely to fail due to loosening.⁷³ They showed that it was possible to minimize the likelihood of fastener loosening failure by optimum placement of threaded fasteners. Since shear force is the main predictor of loosening, it was necessary to consider the effect of slip and side-contact in assemblies with significant slip, for example, when the slip is greater than hole tolerance.

⁶⁸ Dong and Hess 209

⁶⁹ Pai and Hess 383

⁷⁰ Jiang, Zhang, and Lee 2003 A Study 518

⁷¹ Jiang, Zhang, and Lee 2003 A Study 525

⁷² Pai and Hess 2003 Infl of Fastener 617

⁷³ Pai and Hess 2003 Infl of Fastener 617

	NASA Engineering and Safety Center Technical Assessment Report	Document #:	Version:
		NESC-RP-04-092	1.0
Title:		Page #:	
Evaluate the Performance of Loctite® as a Secondary Locking Feature for ISS Fasteners		194 of 205	

2004 Gillis reported on the use of Spiralock® for the NASA Cassini-Huygens mission. The product was selected since it is able to survive the vibration and high temperature launch environment, while also keeping a tight seal for the necessary design components.⁷⁴

2004 Pai and Hess presented a fundamental analysis and experiments which revealed that a fastener can loosen at lower loads than previously expected due to localized slip at the contact surfaces and experimental results confirmed this phenomenon.⁷⁵

2004 Results derived by Jiang, Zhang, Park, and Lee are that the relative displacement of the two clamped plates is the major factor in self-loosening, a larger initial clamping force will result in a higher self-loosening resistance, although may lead to bolt fatigue failure, and that when all other conditions are the same, the use of a washer with a regular nut is better than use of a flange nut.⁷⁶

2004 Zhang, Jiang, and Lee conducted an experimental investigation to study the effects of clamped length and loading direction on the self-loosening of bolted joints.⁷⁷ For a constant preload for each experiment, the joint was subject to cyclic external loading, while the relative displacement between the two clamped plates was a controlling factor.⁷⁸ The conclusions for their study were that: increasing the clamped length can enhance the self-loosening endurance limits in terms of the controlled relative displacement of the two clamped plates, even though the load carrying capability was not influenced significantly due to the plate thicknesses. Additionally, they stated that it was clear having an external load applied in any direction different from the pure shear loading direction would increase the load carrying capability and enhance the self-loosening resistance.⁷⁹

2005 Chen, Hsieh, and Lee investigated the effects of thread lead angle, initial preload, vibration frequency, and the nature of material on bolt loosening behavior. The approach they identified analyzes static and dynamic behaviors, as well as if the bolt is within the elastic range, and is intended as a guide for design a procedure to avoid failures due to vibration.⁸⁰ The main purpose of this paper was to offer an approach to investigating the effects of various factors, static and dynamic, that loosen bolts.⁸¹

⁷⁴ Gillis 1

⁷⁵ Pai and Hess 2004 19

⁷⁶ Jiang, Zhang, Park, and Lee 930

⁷⁷ Zhang, Jiang, Lee 129

⁷⁸ Zhang, Jiang, Lee 129

⁷⁹ Zhang, Jiang, Lee 135

⁸⁰ Chen, Hsieh, Lee 299

⁸¹ Chen, Hsieh, Lee 313

	NASA Engineering and Safety Center Technical Assessment Report	Document #:	Version:
		NESC-RP-04-092	1.0
Title:			Page #:
Evaluate the Performance of Loctite® as a Secondary Locking Feature for ISS Fasteners			195 of 205

2005 Ibrahim and Pettit provided an overview of problems associated with the structural dynamics of bolted joints and identified that the problems are complex since every joint will involve different uncertainties, as well as non-smooth and non-linear characteristics.⁸² Therefore, they provided recommendations for future research areas including experiments that address: additional sinusoidal and random excitation tests that incorporate variability in mechanical properties, various values of preload, long test durations, influence of preload uncertainty on both natural frequency and damping ratio, prying loading, friction forces, and relaxation effects.⁸³

2005 Nassar and Housari used both a mathematical model and an experimental procedure to study the effect of thread and under head coefficients, the hole clearance, and the frequency and the amplitude of the transverse excitation.⁸⁴ The results were that thread lubrication has a more significant effect than under head lubrication, the clamp load loss may or may not be affected by the bolt hole clearance, although it is significant when the external excitation is large enough to cause the bolt head to slide and contact with the edge of the hole, and that frequency does have an effect on fastener self-loosening, since lower frequencies cause more loosening.

J.4 Parameters

The results of these reports have identified many parameters as positively contributing, and others as hindering, the success of a bolted joint subject to vibration. As a summary of the work done by the previously mentioned researchers, the following information provides a listing of the parameters considered to significantly affect the fastener when vibration is a part of the environment for a given product. Bear in mind, there are studies conducted by the Air Force, as well as others, which have identified at least 76 variables that affect the friction constraints between nuts and bolts.⁸⁵ Therefore, the following parameters were selected to be studied based on the context of current research and many have been identified and specifically tested in experiments, while some have been tested only analytically, and still other factors have not yet been analyzed.

First, it is important to be aware that there are multiple causes of failure of a fastener. For example, “self-loosening is commonly caused by vibration but can also be caused by temperature or pressure cycles.”⁸⁶ Fatigue and self-loosening are the most frequent causes of failure of dynamically loaded bolted joints.⁸⁷ Furthermore, there are two major types of

⁸² Ibrahim and Pettit 857

⁸³ Ibrahim and Pettit 913-914

⁸⁴ Nassar and Housari 169

⁸⁵ Bickford Faster Groups Seek 80

⁸⁶ Dong and Hess 1998 816

⁸⁷ Anon 16

	NASA Engineering and Safety Center Technical Assessment Report	Document #: NESC-RP-04-092	Version: 1.0
Title: Evaluate the Performance of Loctite® as a Secondary Locking Feature for ISS Fasteners		Page #: 196 of 205	

vibration which have been found to affect a bolted joint, these are axial and transverse.⁸⁸ It has been determined, by experimental studies, that non-locking fasteners rotate completely loose under transverse vibration.⁸⁹ Generally, it is agreed that vibration is a far greater problem in a joint loaded in shear than only in tension, since the axial loading may only succeed in reducing preload only by about 30 to 40 percent over a long period of time.⁹⁰ Usually, the axial vibration alone will not result in total loss of preload or in complete loss of the fastener.⁹¹ Transverse vibration is definitely more hazardous to bolt vibration loosening than an axial dynamic load. As a result, designers can minimize the slip by orienting the bolts and joints to have axes parallel to the expected direction of vibration.⁹²

Initially, consider the situations that are necessary for vibration loosening of a bolted joint. Bickford discussed the concept of “essential conditions” for situations that effect fasteners in an assembly.⁹³ He stated that self-loosening of the fastener has only two requirements: cyclic loads at right angles to the bolt axis and relative motion (slip) between nut, bolt, and joint members.⁹⁴ Continuing with the discussion, Bickford states:

“The fact that the essential conditions are limited make it appear that it would be relatively easy to avoid joint failure. The problem, however, is that dozens – maybe even hundreds – of secondary conditions can establish the essential conditions required for a particular type of failure.”⁹⁵

These secondary conditions include some of the parameters that researchers have studied to better understand vibration loosening.

There are many factors, or secondary conditions, that influence bolt loosening, possibly 80 to 100 of them. Ramey and Jenkins chose to study 11, of the 80 to 100, they believed were dominant including: bolt size (diameter), lubrication on bolt, hole tolerance, initial preload, locking device, grip length, thread pitch, lubrication between mating surfaces, class of fit, joint configuration, and mass of configuration.⁹⁶ However, in addition to these design parameters, they also considered input factors as well, including: vibration direction, vibration level, vibration frequency, and duration of vibration.⁹⁷ Anon identified that self-loosening can occur when clamping “soft” materials, such as a gasketed cover, where bolt tightness is then often

⁸⁸ Anon 16

⁸⁹ Hardiman

⁹⁰ Bickford An Intro 443

⁹¹ Bickford An Intro 443

⁹² Bickford An Intro 454

⁹³ Bickford An Intro 431

⁹⁴ Bickford An Intro 431

⁹⁵ Bickford An Intro 431

⁹⁶ Hess in Bickford 793

⁹⁷ Hess in Bickford 793

	NASA Engineering and Safety Center Technical Assessment Report	Document #: NESC-RP-04-092	Version: 1.0
Title: Evaluate the Performance of Loctite® as a Secondary Locking Feature for ISS Fasteners			Page #: 197 of 205

determined by the capability of the gasket to support the load.”⁹⁸ Although, even “hard” flanges and gaskets have been identified as having the potential to collapse under the clamping load if there are burrs under the head or poor finishes on the threads, which is a condition called brinelling.⁹⁹

Many of the reports state that preload and friction are the most important factors in a joint to prevent loosening especially in the absence of any secondary locking. Hess states that this is due to the fact that thread and head friction are physically what provide resistance to loosening in a standard threaded fastener, and this friction is proportional to preload. Therefore, the higher the preload, the higher the head and thread friction (for given surface conditions and lubricant) and the higher the resistance to loosening. Bickford notes that for the average bolt-nut combination, the best assurance against shock damage and vibration failure is a tight bolt.¹⁰⁰ Kerley has also documented the importance of preload under dynamic load conditions.¹⁰¹ The list of researchers that support the importance of preload go on to include, but are not limited to: Basava, Chen, Haviland, Hess, Hsieh, Ibrahim, Jenkins, Junker, Lee, Light, Pai, Pettit, Ramey, and Zhang. Preload values are definitely an important consideration for design. In one situation, threads were completely locked together by adhesive, but bolt preload was not sufficient to prevent joint movement and caused the bolt to be partially worn away.¹⁰² Bickford has explicitly stated that, “severe transverse vibration, perpendicular to the axis of the bolt, can, and often does, cause complete loss of preload.”¹⁰³ Again, reiterating the importance of preload and importance for the designer to consider it an essential parameter with respect to self-loosening of fasteners.

Another factor that has been considered important by researchers is the length-to-diameter ratio of the bolt. It has actually been claimed that if a bolt has a length-to-diameter ratio of 8:1 or greater, it will never vibrate loose.¹⁰⁴ With the use of long, thin fasteners instead of slipping when under transverse vibration, the fasteners will bend.¹⁰⁵ Along similar lines, Sakai revealed that the larger the thickness of the clamped parts, the smaller the clearance between the male screw and the female screw, the larger the clamping force, and the smaller the diameter of the bolt, then the less liable the bolt is to loosen.¹⁰⁶ Pai and Hess have also suggested design guidelines to avoid loosening including tighter tolerances, bolts with large length-to-diameter ratios, as well as a larger preload to avoid slip, not just gross slip, but also localized slip.¹⁰⁷

⁹⁸ Anon 18

⁹⁹ Bickford An Introduction 61

¹⁰⁰ Kerley 1980 16 (20 of doc)

¹⁰¹ Kerley 1980 3-41 (99 of doc)

¹⁰² Bolt Science

¹⁰³ Bickford An Intro 443

¹⁰⁴ Bickford That Initial Preload 61

¹⁰⁵ Bickford An Intro 455

¹⁰⁶ Sakai 1387

¹⁰⁷ Pai and Hess 2003 Infl of Fastener 619

	NASA Engineering and Safety Center Technical Assessment Report	Document #: NESC-RP-04-092	Version: 1.0
Title: Evaluate the Performance of Loctite® as a Secondary Locking Feature for ISS Fasteners			Page #: 198 of 205

In some situations, the experimental results of multiple researchers do not agree. For example, Junker initially found no influence of frequency on the self-loosening of fasteners when he tested a non-locking screw.¹⁰⁸ Later he stated

“Tests show that the self-loosening of screws is independent of frequency. It simply depends upon the occurrence of relative motions and on the length of such motions during one cycle. If the forces causing these relative motions are inertia forces, they are a function of the square of the frequency. In this case the frequency indirectly influences the loosening process”¹⁰⁹

Conversely, Kerley discussed some of his own experimentation, as well as how he shared the same view as Haviland, when he stated,

“Tests were performed at GSFC to verify the Haviland theory. When the structure was vibrated at the low frequency, high-amplitude loads (5 g), the nuts backed off in a matter of seconds. When 20 g was applied at 1000 Hz, the bolts had not moved after 10 minutes. In similar fashion, to simulate the multifrequencies of vibration that can occur, random vibration was applied. At 10 grms from 20 to 400 Hz, the nut separated in seconds. At 10 grms from 200 to 2000 Hz, the bolts did not move in 10 minutes. These tests substantiate the theory that low-frequency excitations cause a bolt to back off.”¹¹⁰

Kerley even continued to say that it was possible to keep deflections low in vibration by clamping an assembly on both ends and causing a higher resonant frequency with lower deflections.¹¹¹ Again, he referenced Haviland’s theory that large shearing deflections at a low frequency cause bolts to loosen.¹¹² Further, it was reported that by changing the external load frequency slightly away from the resonant frequency, high levels of vibration, slip and fastener loosening ceased. Hess states that the reason why Kerley’s low frequency test resulted in loosening is that a much larger displacement motion and slip occurred with the lower frequency vibration test. In Kerley’s work, the vibration amplitude in units of displacement are 0.65” at the bolt for the low frequency dwell test and 0.0025” for the high frequency test.

Vibration induced loosening of threaded fasteners is not completely understood as suggested here:

“Our knowledge of vibration loosening is entirely empirical, and there are many factors which can make a difference. Some experiments, in fact, have suggested that complex interactions between suspected factors, perhaps more than the factors

¹⁰⁸ Junker 1969

¹⁰⁹ Junker 1973

¹¹⁰ Kerley 1980 131 (197 of doc)

¹¹¹ Kerley 1980 133 (201 of doc)

¹¹² Kerley 1980 133 (201 of doc)

	NASA Engineering and Safety Center Technical Assessment Report	Document #: NESC-RP-04-092	Version: 1.0
Title: Evaluate the Performance of Loctite® as a Secondary Locking Feature for ISS Fasteners			Page #: 199 of 205

themselves, determine the rate at which a given system will loosen; and/or that there probably are other factors which we have not been able to pin down as yet, which also make a difference. You could easily be fooled by some of these unknown interactions and factors if you tested only a “test joint”¹¹³

For example, Walker reported that thread pitch and prevailing torque, along with a strong interaction between the two were found to be the most significant factors out of those he was considering in his experiment.¹¹⁴ As already mentioned, there may be more of these interactions, which have not been addressed thus far, and they may not be as apparent until they are explicitly considered.

Now consider the addition of an anaerobic adhesive locking element to the bolted joint. Even though there are many parameters that can contribute to the effectiveness of the joint in a vibration environment, considering the use of adhesives adds to the complexity of the situation. The effectiveness of an adhesive can be contributed to many different parameters. Haviland noted that,

“Machinery adhesives, like any durable plastic, can be made to fail by any one or a combination of mechanisms. Examples of such mechanisms are: molecular breakdown by strong chemical reaction, salivation, absorption, stress cracking, mechanical stressing, delamination of adhesion, and desorption, all of which are made more rapid by elevated temperatures. It is rarely necessary to test these phenomena individually because machinery adhesives usually are confined within metal parts that protect the adhesive from exposure except for a very thin bondline. The exposure of only a thin bondline suggests the most important requirement for long-term chemical resistance.”¹¹⁵

The variables of cure speed and initial strength can also be affected by factors such as, presence of air, gap or volume cured, active or inactive surfaces, primer and activator types, temperature, humidity, and finish of the parts.¹¹⁶ In a study of accelerated vibration life testing completed by Dong and Hess, preliminary tests revealed that failure was caused by a combination of preload loss and adhesive degradation.¹¹⁷ Their conclusions suggest their test approach could be developed into a standard life test for threadlocking adhesives.¹¹⁸

¹¹³ Bickford An Intro 450

¹¹⁴ Hess in Bickford 776

¹¹⁵ Haviland 1986 78

¹¹⁶ Haviland 1986 55-67

¹¹⁷ Dong and Hess 817

¹¹⁸ Dong and Hess 817

	NASA Engineering and Safety Center Technical Assessment Report	Document #:	Version:
		NESC-RP-04-092	1.0
Title:		Page #:	
Evaluate the Performance of Loctite® as a Secondary Locking Feature for ISS Fasteners		200 of 205	

With this current state of experimental knowledge about the vibration loosening of threaded fasteners, it is still possible to provide general recommendations for designers and users. Adapted from Bickford and Sauer, here is a list of general guidelines and suggestions for bolted joint design:

- Keep the friction forces in thread and joint surfaces from falling below the forces which are trying to loosen the nut
- Mechanically prevent slip between the nut and bolt or nut and joint surfaces
- Reduce the helix angle of threads to reduce the back-off torque component
- Provide “prevailing torque” or locking action of some sort which counters the back-off torque created by the inclined planes of the threads, and does so even after friction forces in the system have been overwhelmed by vibration.¹¹⁹
- Properly specify the working loads so that the dynamic load will not approach or exceed the static tensile load originally developed in the tightening operation, results indicate that it is desirable to keep the dynamic/static load ratio in the range of 0.7 or less
- Adequately control the method of manufacture, fabrication, assembly, and maintenance so as to have all contact surfaces at the threads, base of nut, and head of bolt in the best possible condition of cleanliness and smoothness
- Improve alignment, as it results in better mating of the contacting parts in somewhat the same manner as does removal of dirt, grease, or surface irregularities¹²⁰

J.5 Testing

Since vibration loosening is not understood well enough to use mathematical models to predict loosening in an assembly, tests must be conducted with test machines.¹²¹ There are different options for test fixture designs that researchers have used. One of the most useful test designs is the Junker transverse vibration machine. Basically, this machine measures residual preload, applied dynamic transverse force, transverse displacement, and number of applied transverse cycles for a fastener under test. A Junker machine is shown in Figure J.1. Additionally, this machine is the basis for a German standard, Deutsches Institut für Normung (DIN) 65151.¹²²

Jiang et al. state that their particular version of the machine lacked displacement control.¹²³ However, most Junker type machines provide very accurate displacement control and measurement using an adjustable eccentric and an LVDT. Many researchers (e.g., Light, Hess,

¹¹⁹ Bickford An Intro 453

¹²⁰ Bickford An Intro

¹²¹ Bickford An Intro 450

¹²² DIN 65151

¹²³ Jiang, Zhang, Park, and Lee

	NASA Engineering and Safety Center Technical Assessment Report	Document #: NESC-RP-04-092	Version: 1.0
Title: Evaluate the Performance of Loctite® as a Secondary Locking Feature for ISS Fasteners			Page #: 201 of 205

etc) and organizations, such as Loctite,¹²⁴ Nord-Lock,¹²⁵ and Hard Lock Industry Co., Ltd.¹²⁶ etc use a Junker type machine for testing and assessing locking features of threaded fasteners.

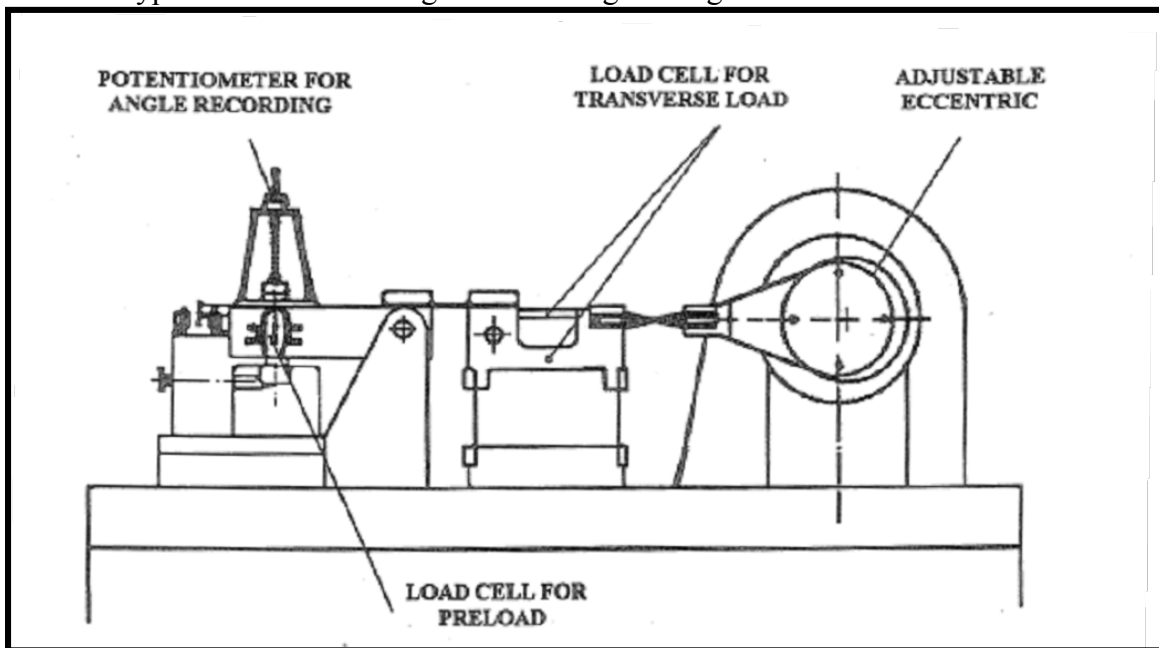

Figure J.1. Junker Vibration Test Machine

Another experimental test fixture used is the Aerospace Locknut Manufacturer's Association (ALMA) test, also designated as the MIL-STD-1312-7 or more recently the NASM-1312-7 vibration test. It has been stated that the ALMA test fixture design is easy to setup and run¹²⁷, however,

“Some people, however, believe that it is more pertinent to measure the actual magnitude of the force exerted on the joint under test and/or the actual displacement of joint members. This is not possible with the ALMA test. You can measure the amplitude of the shake table, but it is difficult to tell what, if any, displacement has actually resulted between the fastener and the test cylinder – or determine the forces

¹²⁴ Loctite

¹²⁵ Nordlock

¹²⁶ Hardlock

¹²⁷ Bickford An Intro 451

	NASA Engineering and Safety Center Technical Assessment Report	Document #: NESC-RP-04-092	Version: 1.0
Title: Evaluate the Performance of Loctite® as a Secondary Locking Feature for ISS Fasteners			Page #: 202 of 205

on the fastener – because both of these depend on impact, and impact is very difficult to predict or control.”¹²⁸

Figure J.2 shows a picture of an ALMA test fixture designed to test one bolt.

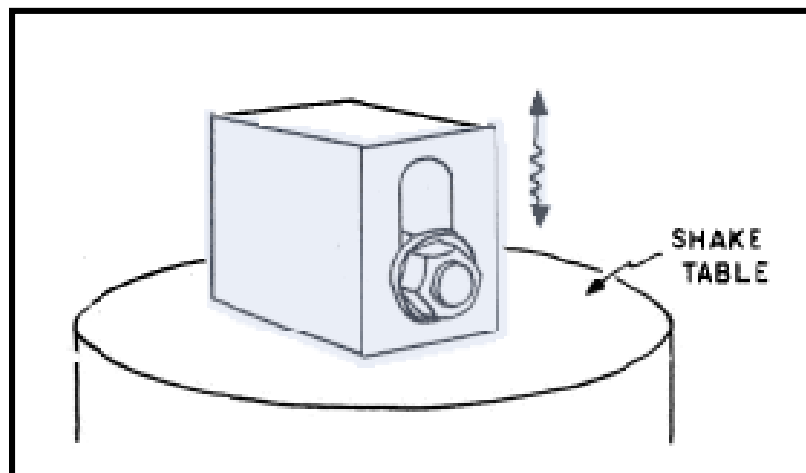

*Figure J.2. ALMA Test Fixture Example*¹²⁹

Haviland and Kerley used another type of vibration test fixture. It consisted of a compound beam mounted to a vibration shaker machine. In this design, the bolted joint being tested clamps the beam, which induces shear to the fastener as a result of bending of the beam.¹³⁰ Figure J.3 shows one example of this apparatus. Dong and Hess also used this type of fixture when they conducted accelerated vibration life tests of threadlocking adhesives.¹³¹

¹²⁸ Bickford An Intro 451

¹²⁹ Bickford (book) 1990

¹³⁰ Kerley NASA TM 4001 15 (21 of doc)

¹³¹ Dong and Hess Acceled Vib. 816



NASA Engineering and Safety Center Technical Assessment Report

Document #:
**NESC-RP-
04-092**

Version:
1.0

Title:

Evaluate the Performance of Loctite® as a Secondary Locking Feature for ISS Fasteners

Page #:
203 of 205

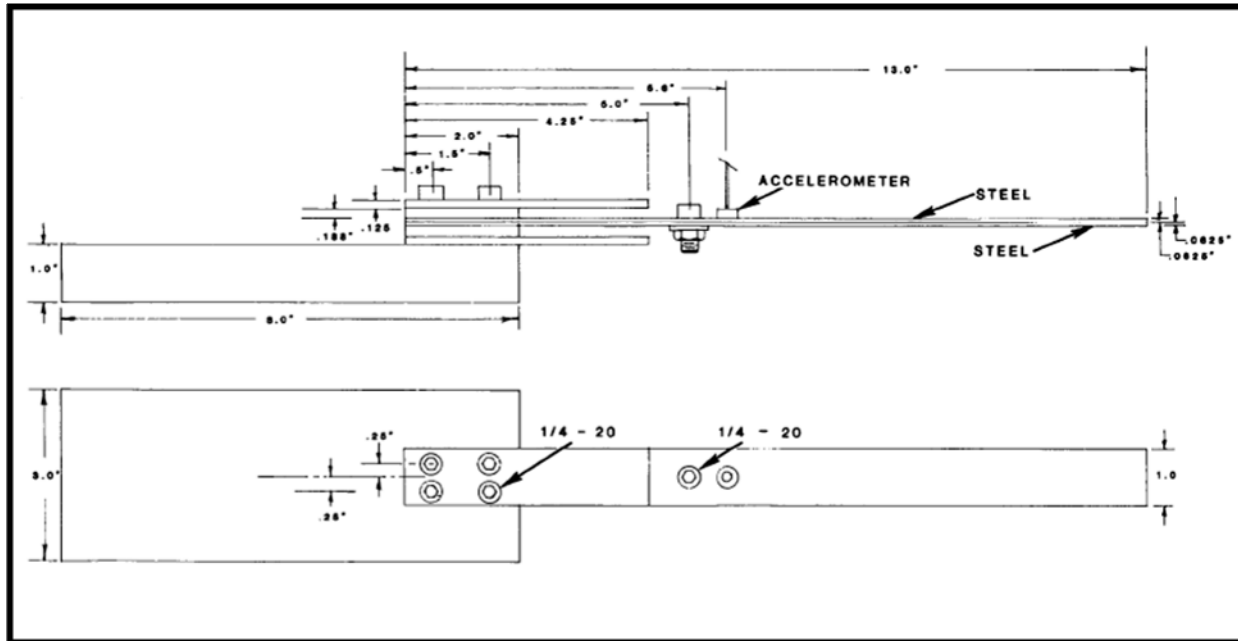

*Figure J.3. Kerley Test Fixture Design*¹³²

Other test fixtures have focused on the axial loading of the fasteners, but since the focus of many of the reports have been on transverse loading, a discussion on axial fixture designs is not provided here.

Each of the researchers have taken the approach that, the most common and easiest way to loosen a bolted assembly is by inducing transverse slip.¹³³ However, it has been identified by Haviland, of Loctite® Corporation, that,

“Predicting the suitability or life of any material for a particular application or environment is difficult without extensive field tests that duplicate the proposed environment. This is especially true for adhesive systems because the adhesive is only half of the system.”¹³⁴

Possible dynamic tests should be performed on the system itself.¹³⁵ Of course, theoretically, when you test a fastener for vibration resistance, you would like to subject it to the vibration

¹³² From Kerley NASA TM 4001 pg 46 of report

¹³³ Haviland 1983

¹³⁴ Haviland 1986 78

¹³⁵ Bickford An Intro 450

	NASA Engineering and Safety Center Technical Assessment Report	Document #: NESC-RP-04-092	Version: 1.0
Title: Evaluate the Performance of Loctite® as a Secondary Locking Feature for ISS Fasteners			Page #: 204 of 205

frequencies and magnitudes you expect the joint to encounter in your application, but predicting the vibration environment in a given product is even more difficult than predicting external loads.¹³⁶ This is not widely agreed upon. Bickford notes that the “only recourse is to provide a fastener system that is immune to the range of frequencies you expect it might encounter in practice and then to determine by trial and error whether or not you have been successful.”¹³⁷

It should also be noted that the ASME/ANSI subcommittee previously mentioned started to screen fastener testing equipment that would be best appropriate for conducting experiments.¹³⁸ However, no reports on their findings have been located through an extensive search in multiple library databases, as well as contacting members of the organizations directly.^{139, 140}

J.6 Summary

With regards to the self-loosening of bolted joints, there are many experiments and research studies that have been completed to develop theories and models, and to assess and compare locking features performance. Some of the theories are more widely accepted than others, although many agree that the topic is broad and a full understanding of the issue has not been accomplished thus far. It is generally agreed upon by researchers that, “dynamic transverse forces are more dangerous than dynamic axial forces”¹⁴¹ from a loosening perspective. This has led to a couple test fixture and test machine designs that have been used to study the loosening of threaded fasteners.

There have been many researchers that have helped improve our understanding of how fasteners react to different environments, specifically vibration. However, none have derived end-all solutions for the loosening problem. It has been identified that the comprehensive research plan the Subcommittee on the Loosening Mechanism of Bolted Joints Under Vibration created was not performed due to a lack of funding for the research.¹⁴² Consequently, the group did not continue with the test plan, nor did organizations which hosted this subcommittee retain records of the fact that there was a subcommittee devoted to this topic, nor do the organizations have any documentation on any of the findings of the group, since all records, including meeting minutes, are discarded, based on company policy.^{143, 144}

¹³⁶ Bickford An Intro 452

¹³⁷ Bickford An Intro 452

¹³⁸ Pearce, M. B. 1

¹³⁹ Personal Correspondence ASME

¹⁴⁰ Personal Correspondence ANSI

¹⁴¹ Junker 1969

¹⁴² Hess in Bickford 782

¹⁴³ Personal Correspondence ASME

¹⁴⁴ Personal Correspondence ANSI

	<p align="center">NASA Engineering and Safety Center Technical Assessment Report</p>	<p align="center">Document #: NESC-RP- 04-092</p>	<p align="center">Version: 1.0</p>
<p>Title: Evaluate the Performance of Loctite® as a Secondary Locking Feature for ISS Fasteners</p>		<p align="center">Page #: 205 of 205</p>	

The subcommittee stated that an extensive experimental analysis is necessary if a better understanding of the issue of self-loosening of bolted joints is necessary. This was done to a large extent in a nine-year effort by the British Aircraft Corporation and funded by the British Ministry of Defense. This work is summarized in the paper by Light with about 2,500 pages of test and analyses details in several reports referenced by Light.

REPORT DOCUMENTATION PAGE

*Form Approved
OMB No. 0704-0188*

The public reporting burden for this collection of information is estimated to average 1 hour per response, including the time for reviewing instructions, searching existing data sources, gathering and maintaining the data needed, and completing and reviewing the collection of information. Send comments regarding this burden estimate or any other aspect of this collection of information, including suggestions for reducing this burden, to Department of Defense, Washington Headquarters Services, Directorate for Information Operations and Reports (0704-0188), 1215 Jefferson Davis Highway, Suite 1204, Arlington, VA 22202-4302. Respondents should be aware that notwithstanding any other provision of law, no person shall be subject to any penalty for failing to comply with a collection of information if it does not display a currently valid OMB control number.
PLEASE DO NOT RETURN YOUR FORM TO THE ABOVE ADDRESS.

1. REPORT DATE (DD-MM-YYYY) 01-03-2011		2. REPORT TYPE Technical Memorandum		3. DATES COVERED (From - To) December 2004 - December 2010	
4. TITLE AND SUBTITLE Performance Characterization of Loctite® 242 and 271 Liquid Locking Compounds (LLCs) as a Secondary Locking Feature for International Space Station (ISS) Fasteners				5a. CONTRACT NUMBER	
				5b. GRANT NUMBER	
				5c. PROGRAM ELEMENT NUMBER	
				5d. PROJECT NUMBER	
				5e. TASK NUMBER	
				5f. WORK UNIT NUMBER 869021.05.07.03.03	
6. AUTHOR(S) Dube, Michael J.; Gamwell, Wayne R.					
7. PERFORMING ORGANIZATION NAME(S) AND ADDRESS(ES) NASA Langley Research Center Hampton, VA 23681-2199				8. PERFORMING ORGANIZATION REPORT NUMBER L-19999 NESC-RP-04-092	
9. SPONSORING/MONITORING AGENCY NAME(S) AND ADDRESS(ES) National Aeronautics and Space Administration Washington, DC 20546-0001				10. SPONSOR/MONITOR'S ACRONYM(S) NASA	
				11. SPONSOR/MONITOR'S REPORT NUMBER(S) NASA/TM-2011-217068	
12. DISTRIBUTION/AVAILABILITY STATEMENT Unclassified - Unlimited Subject Category 16 - Space Transportation and Safety Availability: NASA CASI (443) 757-5802					
13. SUPPLEMENTARY NOTES					
14. ABSTRACT Several International Space Station (ISS) hardware components use Loctite® (and other polymer based liquid locking compounds (LLCs)) as a means of meeting the secondary (redundant) locking feature requirement for fasteners. The primary locking method is the fastener preload, with the application of the Loctite® compound which when cured is intended to resist preload reduction. The reliability of these compounds has been questioned due to a number of failures during ground testing. The ISS Program Manager requested the NASA Engineering and Safety Center (NESC) to characterize and quantify sensitivities of Loctite® being used as a secondary locking feature. The findings and recommendations provided in this investigation apply to the anaerobic LLCs Loctite® 242 and 271. No other anaerobic LLCs were evaluated for this investigation. This document contains the findings and recommendations of the NESC investigation.					
15. SUBJECT TERMS International Space Station; Loctite®; liquid locking compounds; NASA Engineering and Safety Center					
16. SECURITY CLASSIFICATION OF:			17. LIMITATION OF ABSTRACT	18. NUMBER OF PAGES	19a. NAME OF RESPONSIBLE PERSON
a. REPORT	b. ABSTRACT	c. THIS PAGE			STI Help Desk (email: help@sti.nasa.gov)
U	U	U	UU	210	19b. TELEPHONE NUMBER (Include area code) (443) 757-5802