



## Overview of Lightweight Structures for Rotorcraft Engines & Drivetrains

This is an overview presentation of research being performed in the Advanced Materials Task within the NASA Subsonic Rotary Wing Project. This research is focused on technology areas that address both national goals and project goals for advanced rotorcraft. Specific technology areas discussed are: (1) high temperature materials for advanced turbines in turboshaft engines; (2) polymer matrix composites for lightweight drive system components; (3) lightweight structure approaches for noise and vibration control; and (4) an advanced metal alloy for lighter weight bearings and more reliable mechanical components. An overview of the technology in each area is discussed, and recent accomplishments are presented.



# Fundamental Aeronautics Program

## *Subsonic Rotary Wing Project*

### Overview of Lightweight Structures for Rotorcraft Engines & Drivetrains

Dr. Gary D. Roberts  
Technical Lead, Advanced Materials (GRC)  
Subsonic Rotary Wing Project



2011 Technical Conference  
March 15-17, 2011  
Cleveland, OH

# SRW Project Organization



PROJECT LEVEL

**Technical Challenges**

Project Manager: Susan Gorton  
 Deputy Project Manager: Isaac López  
 Additional Functions as Needed

Deputy Project Manager For ARC: Bob Kufeld      Deputy Project Manager For GRC: TBD      Deputy Project Manager For LaRC: Odilyn Luck

SUB-PROJECT LEVEL

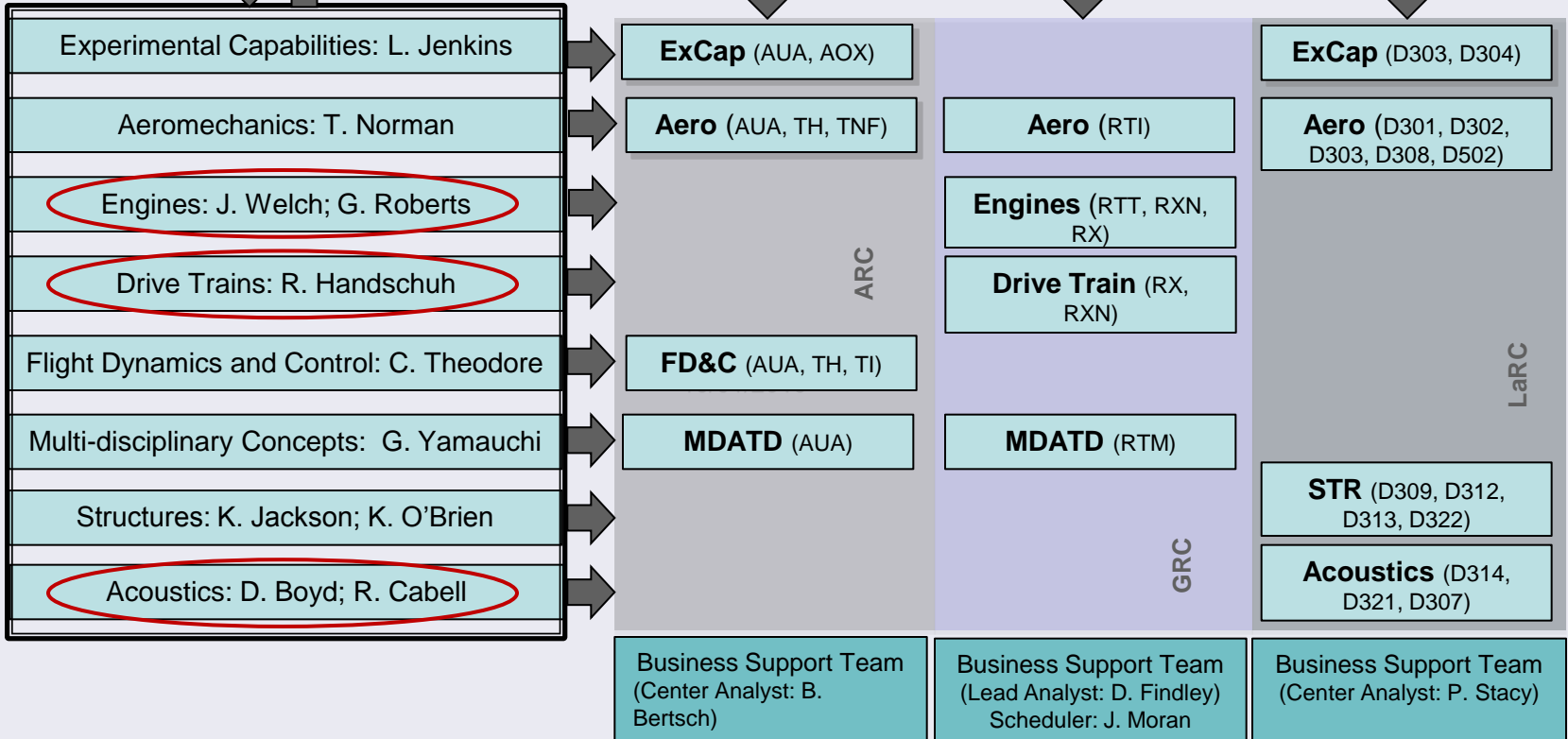

# Advanced Materials Technology Areas



## National goals:

- Mobility: Goal 5 – Expanded capabilities
- Energy and environment: Goal 3 – Reduced environmental impact
- National defense: Goal 2 – Improved rotorcraft

## SRW goals:

- Radically improve the transportation system using rotary wing vehicles by increasing speed, range, and payload while decreasing noise, vibration and emissions

## SRW Propulsion/Advanced Materials (GRC) research areas:

### Efficient turboshaft engines

- Erosion resistant thermal barrier coatings for turbine blades
- Ceramic matrix composites (CMC's) for vanes and blades

### Lightweight drive system components

- Composite materials for static and rotating components
- Advanced alloys for bearings and mechanical components

### Lightweight structures

- Integration of passive vibration control and acoustic treatment in composite structures
- Multiscale modeling of vibration in composite materials and structures

# Erosion resistant thermal barrier coatings

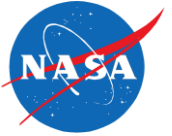

Technology description: (POC: Bob Miller)

- Develop advanced erosion resistant thermal barrier coatings for turbine blades
- Optimize coating composition and deposition conditions for blade geometries
- Develop physics based erosion model

Technical challenges:

- Optimize coating composition and microstructure for erosion resistance under the combined effects of temperature and oxidation
- Develop a laboratory test rig that replicates the erosion damage observed in engines
- Fully understand and model effects of microstructure, environment, and particulates on TBC erosion

Test Articles

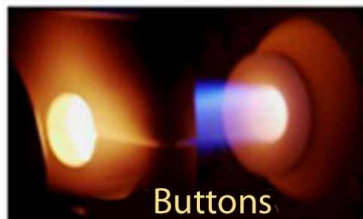

New Ducted Rig (MACH 0.3 to 0.7, up to 2200°F)

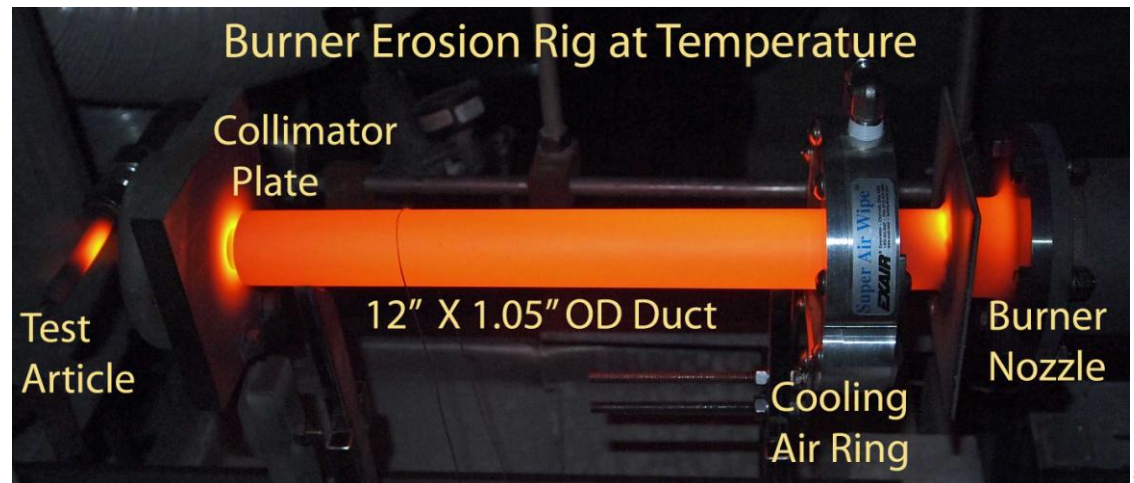

# Erosion resistant thermal barrier coatings

---



## Rotorcraft applications:

- Coatings for turbine blades in turboshaft engines

## Benefits:

- Coatings with improved erosion resistance at higher temperatures enable engine operation at higher power density (higher temperature and pressure)
- Reduced fuel burn, reduced emissions, and lower weight
- Improved sintering and erosion resistance results in greater reliability and reduced maintenance

## Contracts and external agreements:

- Improved coating technology is ready for engine testing if an opportunity becomes available

# Erosion resistant thermal barrier coatings



## Recent results:

- Improved erosion life was demonstrated for the  $\text{ZrO}_2\text{-Y}_2\text{O}_3\text{-Gd}_2\text{O}_3\text{-Yb}_2\text{O}_3$  composition
- Processing by DVD (directed vapor deposition) was done by DVTI under an Army SBIR
- DVD provided 2X improvement vs 1.5X for conventional PVD (physical vapor deposition)
- Lower conductivity and improved sintering resistance were also achieved
- Currently evaluating further improvements using transition metal additions ( $\text{TiO}_2$ ,  $\text{Ta}_2\text{O}_5$ )
  - DVD and new plasma PVD (in-house) have potential for these improvements

## Erosion life relative to baseline

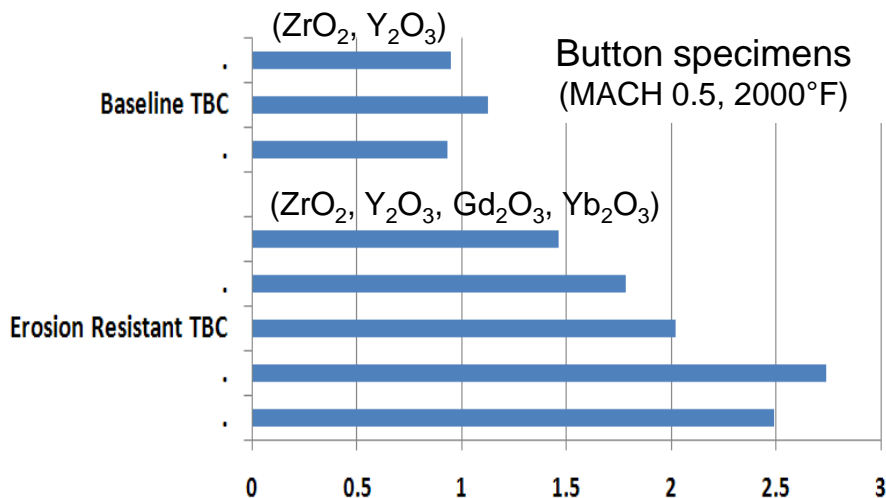

Need to optimize coating on convex side of leading edge where microstructure is less resistant to erosion

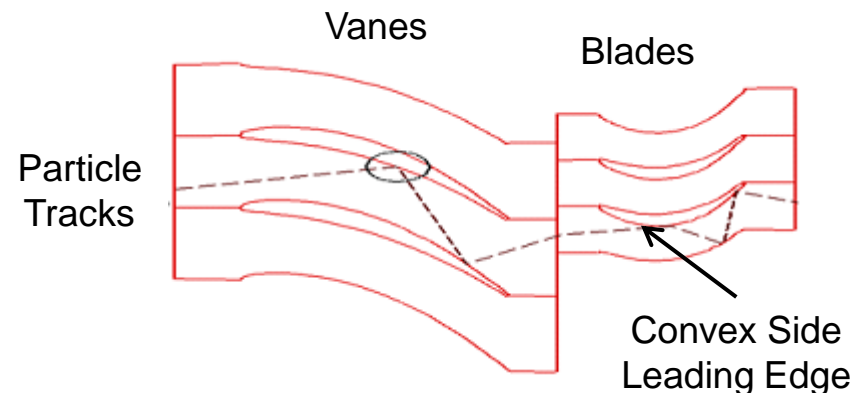

(Figure from NRA with the University of Cincinnati)

# Ceramic matrix composite (CMC) vanes



Technology description: (POC: Mike Halbig)

- Develop technologies for CMC turbine components (fabrication methods, bonding, and environmental barrier coatings)
- First demonstration on vanes (two concepts are being evaluated) with possible future work on blades

Technical challenges:

- Fabrication of small (~1 in) parts (small radii, thin trailing edges, small cooling channels)
- Bonding methods (diffusion bonding and brazing)

## Internally Cooled Vane

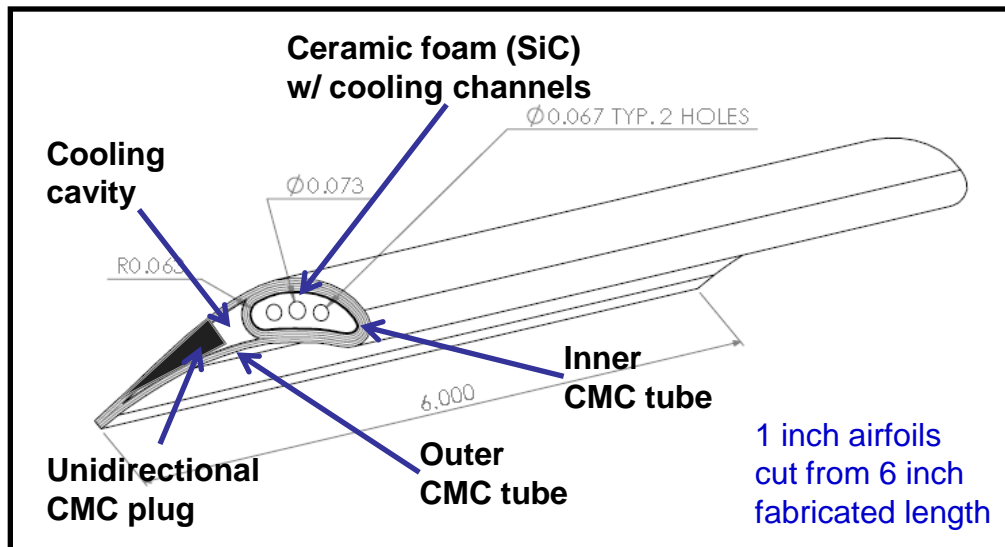

## Film Cooled Vane

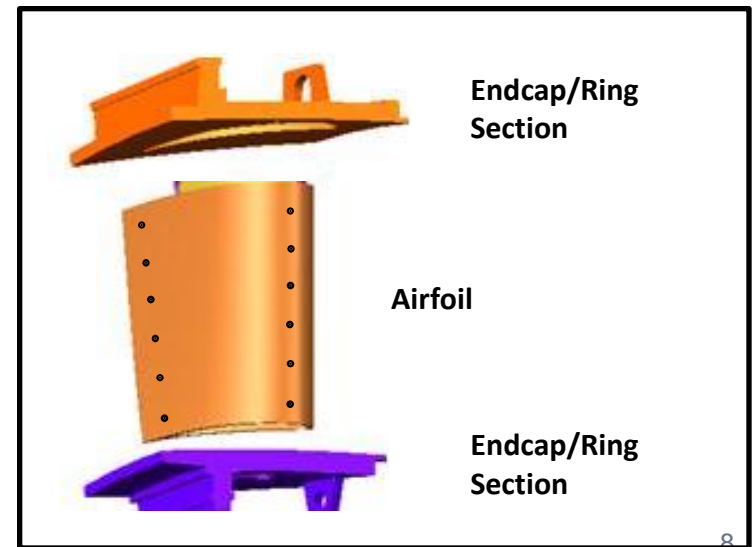



# Ceramic matrix composite (CMC) vanes

---



## Rotorcraft applications:

- HPT vanes in turboshaft engines
- Combustor liners, shrouds, blades of the HPT, and blades and vanes of the low pressure turbine (LPT) stages

## Benefits:

- Higher temperature capability of CMC vanes enables engine operation at higher power density (higher temperature and pressure)
- Reduced fuel burn, reduced emissions, and lower weight
- Reduced cooling results in improved efficiency

## Contracts and external agreements:

- N&R Engineering (Phase 2 SBIR)
  - Investigation of cooling schemes and stress analysis in the airfoil

# Ceramic matrix composite (CMC) vanes



## Recent results:

- Bonding of SiC/SiC CMC's by high temperature ceramic brazing using a Si-Hf eutectic paste has been evaluated
- Brazing does not require high loads (as required for diffusion bonding)
- Joints had good adhesion, no microcracking, no fiber delaminations, but some gaps and non-uniformity
- Eutectic tape interlayers are being evaluated to eliminate gaps and provide more uniformity

Joining of SA-Tyrannohex to SA-Tyrannohex (SiC fiber material) using a Si-Hf eutectic paste

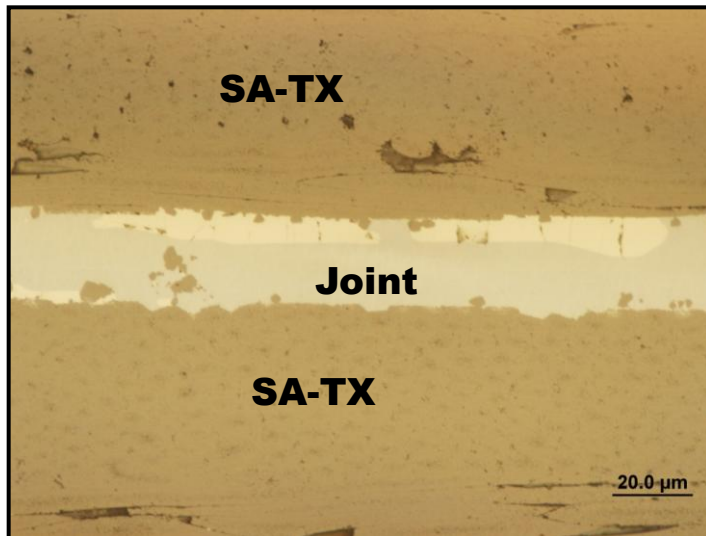

(100X magnification)

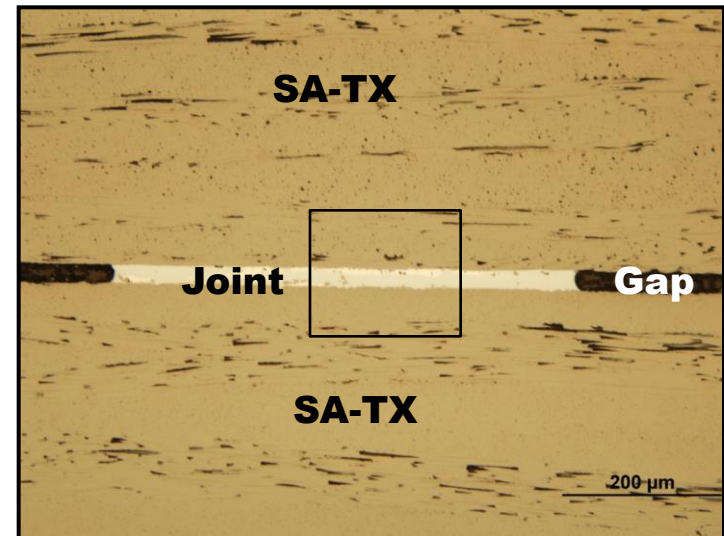

(20X magnification)

# Lightweight structures

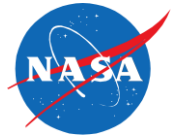

Technology description: (POC: Chris Johnston)

- Evaluate the use of lightweight composite materials for static and rotating drive system components
- Evaluate composite materials and structures approaches for vibration and cabin noise reduction

Technical challenges:

- Develop laboratory test methods to simulate loads on drive system components
- Develop methods to monitor both local and global deformation during rotating component tests
- Develop reliable material screening tests for evaluation of material options for improved damping
- Apply multi-scale models to guide design for combined structural capability and vibration reduction

Surface displacement with rigid body motion subtracted for a disk rotating at 10,000 RPM

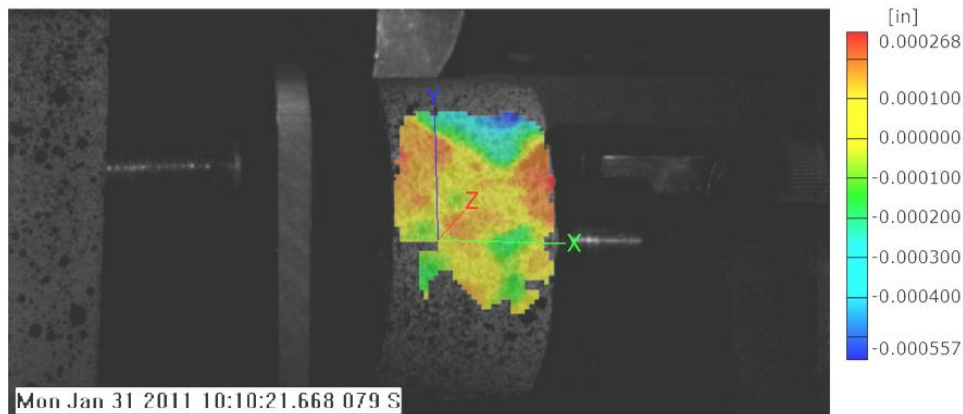

Test methods for damping in composite materials and structures

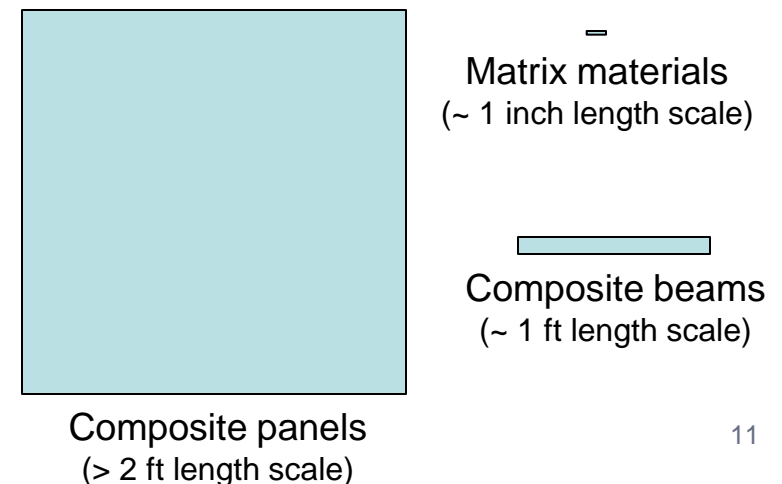

# Lightweight structures

---



## Rotorcraft applications:

- Lightweight shafts, couplings, housings, gears
- Passive approaches for control of vibration close to the source (gearbox)
- Airframe structure with integrated passive vibration and noise control

## Benefits:

- Significant weight reduction for future heavy lift and high speed vehicles
- Cabin noise and vibration reduction with minimum addition of parasitic weight

## Partnerships:

- Exploring possibilities for partnerships in these areas

# Lightweight structures (vibration reduction)

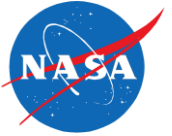

## Recent results:

- A preliminary evaluation of various material approaches for providing damping is in progress
- The variability of damping measurements obtained using standard DMA (dynamic mechanical analysis) instrumentation was determined to be about +/- 25%
- Application of a graphite sheet coating was identified as a possible approach
  - 300% increase over a wide temperature range
  - Can be applied to a wide range of materials
  - Low cost approach

## Effect of a graphite sheet coating on damping (sheet applied to an epoxy resin specimen)

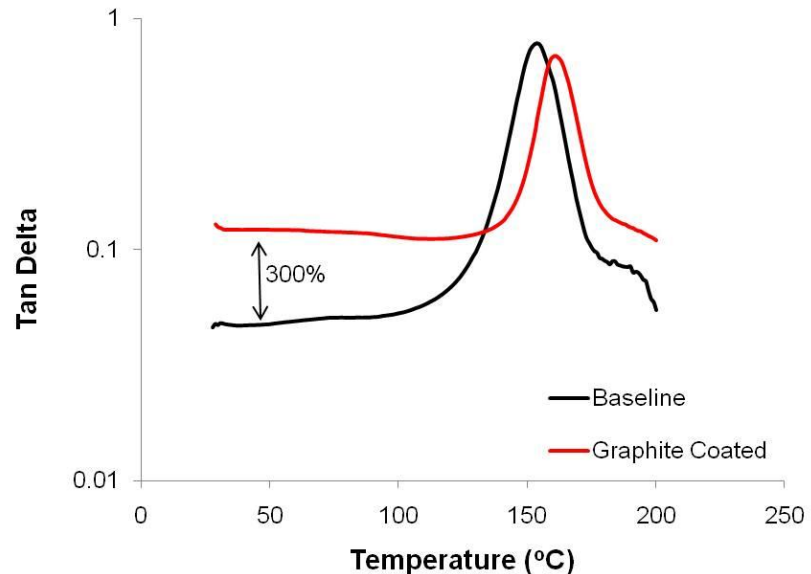

## Material damping approaches

- Carbon nanotubes
- Carbon nanofibers
- Graphene
- Nano-clays
- Graphite
- Coatings

# 60-NiTiNOL Metal Alloy



Technology description: (POC: Chris Dellacorte)

- Evaluate superelastic (high compression strain) alloys for shock resistant rotorcraft bearings and mechanical components
- Optimize composition and processing conditions of Nickel-Titanium alloys for rotorcraft applications

Technical challenges:

- Demonstrate feasibility of using superelastic alloys (high hardness/modulus ratio) vs traditional approach (high hardness and high modulus)
- Develop alloy formulations and processes to optimize shock, erosion, and fatigue resistance

Cyclic compression stress-strain curves

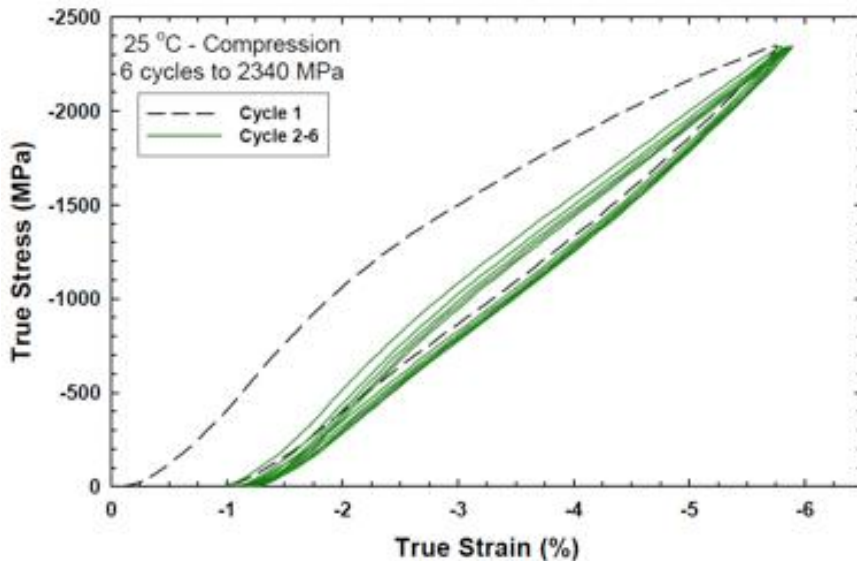

- Elastic strain of >4% vs <1% for conventional bearing alloys is better for shock resistance
- Processing conditions must be optimized for erosion and fatigue resistance
- Prestressing is needed to account for inelasticity in the first cycle

# 60-NiTiNOL Metal Alloy

---



## Rotorcraft applications:

- Bearings, gears, main and tail rotor mechanisms, and driveline components

## Benefits:

- 60NiTi compared to conventional steel alloys:
  - 15% lighter
  - Can endure 10X higher concentrated shock-impact loads
  - Immune to corrosion
- These capabilities offer the potential for smaller/lighter weight components and more robust and reliable mechanical systems

## Partnerships:

- Pathfinder project to design and fabricate 50mm ball bearing for aerospace use. Team includes bearing manufacturers, multiple NASA Centers and support from both ARMD and the NESC.

# 60-NiTiNOL Metal Alloy



## Recent results:

- Indentation tests demonstrate that 60NiTi can withstand higher loads than conventional steel alloys without incurring damage

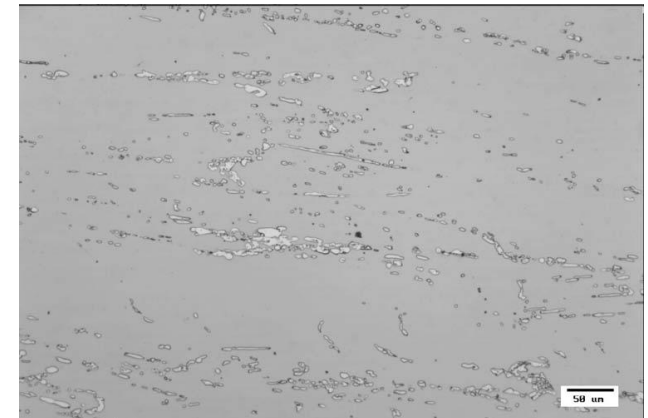
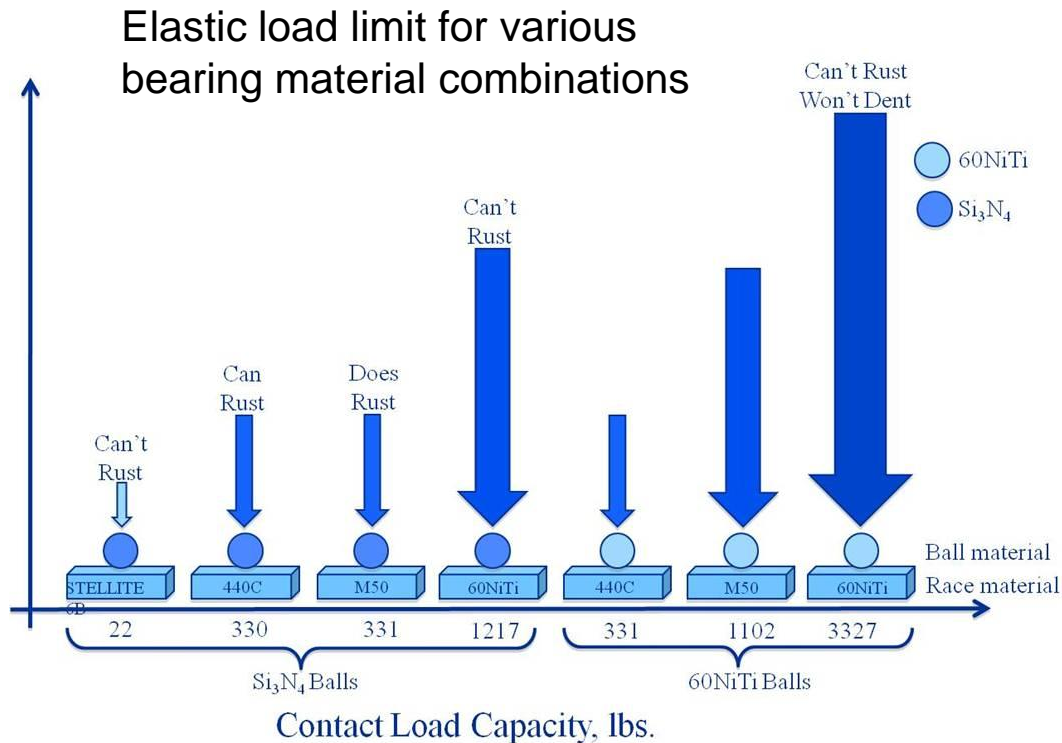

Optical micrograph showing voids and second phase precipitates that must be removed to improve fatigue resistance



