

NASA/CR—2008–215412

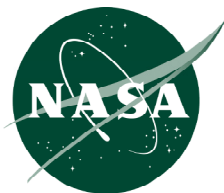

Experimental Plans for Subsystems of a Shock Wave Driven Gas Core Reactor

F. Kazeminezhad

Institute for Scientific Research, Fairmont, West Virginia

S. Anghai

University of Florida, Gainesville, Florida

Prepared for Marshall Space Flight Center
under Contract Number NCC8–225

June 2008

The NASA STI Program...in Profile

Since its founding, NASA has been dedicated to the advancement of aeronautics and space science. The NASA Scientific and Technical Information (STI) Program Office plays a key part in helping NASA maintain this important role.

The NASA STI program operates under the auspices of the Agency Chief Information Officer. It collects, organizes, provides for archiving, and disseminates NASA's STI. The NASA STI program provides access to the NASA Aeronautics and Space Database and its public interface, the NASA Technical Report Server, thus providing one of the largest collections of aeronautical and space science STI in the world. Results are published in both non-NASA channels and by NASA in the NASA STI Report Series, which includes the following report types:

- **TECHNICAL PUBLICATION.** Reports of completed research or a major significant phase of research that present the results of NASA programs and include extensive data or theoretical analysis. Includes compilations of significant scientific and technical data and information deemed to be of continuing reference value. NASA's counterpart of peer-reviewed formal professional papers but has less stringent limitations on manuscript length and extent of graphic presentations.
- **TECHNICAL MEMORANDUM.** Scientific and technical findings that are preliminary or of specialized interest, e.g., quick release reports, working papers, and bibliographies that contain minimal annotation. Does not contain extensive analysis.
- **CONTRACTOR REPORT.** Scientific and technical findings by NASA-sponsored contractors and grantees.

- **CONFERENCE PUBLICATION.** Collected papers from scientific and technical conferences, symposia, seminars, or other meetings sponsored or cosponsored by NASA.
- **SPECIAL PUBLICATION.** Scientific, technical, or historical information from NASA programs, projects, and missions, often concerned with subjects having substantial public interest.
- **TECHNICAL TRANSLATION.** English-language translations of foreign scientific and technical material pertinent to NASA's mission.

Specialized services also include creating custom thesauri, building customized databases, and organizing and publishing research results.

For more information about the NASA STI program, see the following:

- Access the NASA STI program home page at <<http://www.sti.nasa.gov>>
- E-mail your question via the Internet to <help@sti.nasa.gov>
- Fax your question to the NASA STI Help Desk at 301-621-0134
- Phone the NASA STI Help Desk at 301-621-0390
- Write to:
NASA STI Help Desk
NASA Center for AeroSpace Information
7115 Standard Drive
Hanover, MD 21076-1320

NASA/CR—2008–215412



Experimental Plans for Subsystems of a Shock Wave Driven Gas Core Reactor

*F. Kazeminezhad
Institute for Scientific Research, Fairmont, West Virginia*

*S. Anghai
University of Florida, Gainesville, Florida*

Prepared for Marshall Space Flight Center
under Contract Number NCC8–225

June 2008

Acknowledgments

This research report is a result of extensive collaboration between the Institute for Scientific Research (ISR) and the University of Florida, Innovative Nuclear Space Power and Propulsion Institute (INSPI), along with its small business partner NeTech. During the course of this project, INSPI was funded, in part, as a subcontractor to ISR. However, INSPI and its small business partner, NeTech, have been funded by NASA Marshall Space Flight Center for six years prior to this activity to conduct research on various aspects of gas core reactors and magneto-hydrodynamic power conversion for space power and propulsion. Major portions of this report are the product of work by Dr. Samim Anghaie, Dr. Travis Knight, and Dr. Blair Smith funded under this project and, to some degree, derived from work performed on other NASA research contracts. The significant and invaluable contributions of Drs. Anghaie, Knight, and Smith to the concept of gas core reactors for space power and propulsion are expressly acknowledged and sincerely appreciated.

Available from:

NASA Center for AeroSpace Information
7115 Standard Drive
Hanover, MD 21076-1320
301-621-0390

This report is also available in electronic form at
<<https://www2.sti.nasa.gov>>

TABLE OF CONTENTS

1. INTRODUCTION	1
2. ESTIMATION OF THE INPUT ENERGY	3
3. CALCULATION OF THE REQUIRED COIL CURRENT	4
4. SHOCK GENERATION EXPERIMENTS	8
4.1 Diagnostic Tools	8
4.2 Pulse Field Generators	8
5. SHOCK COLLISION EXPERIMENTS	14
6. FUEL AND MATERIAL PROPERTY EXPERIMENTS	15
REFERENCES	17

LIST OF FIGURES

1.	Conceptual design for a high pressure ionized shock generator pulsed magnetic fission reactor with magnetocumulative flux compression power generator (MSC/FCG)	2
2.	Pressure vs. number density	4
3.	Inductance of a ring vs. diameter	5
4.	Magnetic field vs. pressure	6
5.	The 50 T magnet schematic	10
6.	Schematic of the 20 T superconducting magnet	11
7.	Schematic of the 40 T pulsed magnet	12
8.	Existing unit for generation of high field EM pulses	13
9.	Schematic of the circuit diagram for the EM pulse generator device of Figure 8	14

1 INTRODUCTION

This report proposes a number of plans for experiments on subsystems of a shock wave driven pulsed magnetic induction gas core reactor (PMI-GCR, or PMD-GCR pulsed magnet driven gas core reactor). Computer models of shock generation and collision in a large-scale PMI-GCR shock tube have been performed. Based upon the simulation results a number of issues arose that can only be addressed adequately by capturing experimental data on high pressure (~ 1 atmosphere or greater) partial plasma shock wave effects in large bore shock tubes (≥ 10 cm radius). Here are three main subsystems that are of immediate interest (for appraisal of the concept viability). These are (1) the shock generation in a high pressure gas using either a plasma thruster or pulsed high magnetic field, (2) collision of MHD or gas dynamic shocks, their interaction time, and collision pile-up region thickness, (3) magnetic flux compression power generation. Of these subsystems only (1) and (2) will be considered in this report, upon which rest the majority burden of viability for the reactor concept.

Further in this introduction, a discussion is made of the two types of pulsed reactors based on the method of shockwave generation. In addition, some estimates are made for the input power required and for coil current as they directly impact the choice and design of experiments. Besides the three identified subsystems, experiments are needed on basic properties of materials and fuel, these are discussed in Section 6. Section 4 will report on the more critical experimental plans for the shock generation subsystem, Section 5 will outline plans for experiments to investigate the collision and interaction of shocks.

A schematic of the conceptual design for the PMI-GCR is shown in Figure 1. This is the latest of three or four conceptual designs and represents the most fully formed concept to date, incorporating all three prior aspects of, shock wave generation, shock collision and fission energy release, and magnetic flux compression power generation, in addition to a new fourth component, a radial compaction of plasma by θ -pinch for preventing the charged fission fragments from escaping the interaction region.

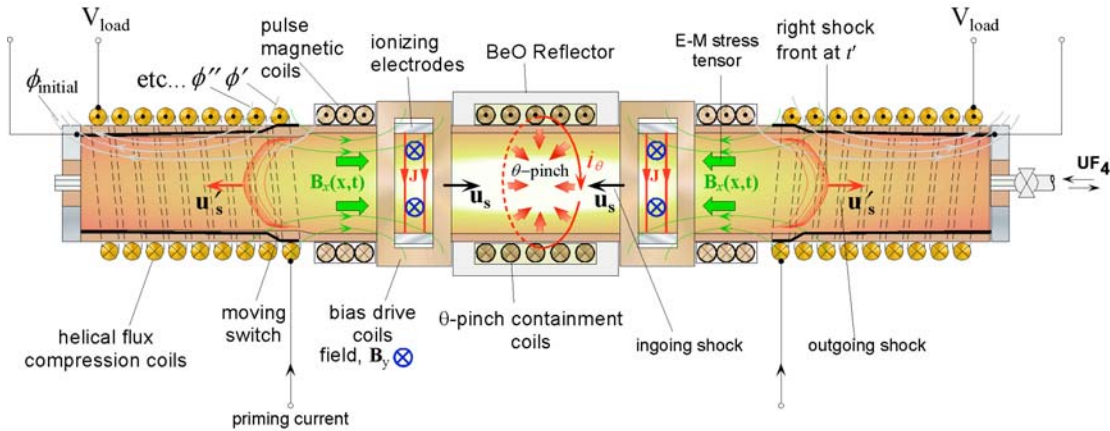

Figure 1 Conceptual design for a high pressure ionized shock generator pulsed magnetic fission reactor with magnetocumulative flux compression power generator (MFC/FCG).

There are many variations that could be generated but this report is concerned only with two specific classes of pulsed magnetic field shock-driven reactor. One is termed an “MPD compressor mode” device; the other is a “pulsed high magnetic field” device. The distinction between the two types is based upon the method of shock wave generation at each end of the shock tube reactor. In practice the distinction between these two shock generation methods (“compressor-type” and “pulsed-type”) becomes blurred and indistinguishable when the pulse time is set fairly large and the current density at the boundary is reduced, for in that case a pulse becomes almost indistinguishable from a short duration MPD-compressor mode. The reason why a sharp distinction cannot always be made is because in order to operate in a pulsed high B -field mode the gas fuel has to be highly ionized, this generally requires a current discharge through the gas, and so ponderomotive force effects will play a dominant role in addition to the desired magnetic discontinuity shock inducing effect. Thus, for high B -fields, shock waves will be created in the gas through two effects, one through the ponderomotive force and the other via magnetic and the resulting pressure discontinuity effect. These two effects may compete or cooperate depending upon the design of the shock generator, its geometry and electrode configuration. The immediate plan for experiment is to build a pulsed high magnetic field device that would require fewer resources due to availability of existing facilities.

2 ESTIMATION OF THE INPUT ENERGY

To achieve a self-sustaining nuclear chain reaction in a given volume of gas with a given geometry it is necessary that at least one of the neutrons emitted in each fission reaction triggers in turn, a new fission. This situation is usually indicated by an effective multiplication factor of one ($k_{\text{eff}} = 1$). The result of specific interest for this discussion is that a shocktube with a diameter of 1.97-m and thickness of 0.34-m shockwave interaction region of uranium tetrafluoride (UF_4) is required to attain $k_{\text{eff}} = 1$. This corresponds to 1.9×10^{21} atoms of ^{235}U per cubic centimeter, or to a gas pressure of 7.5×10^6 Pa, as shown in Figure 2. The value of the pV , energy stored in this critical core, is given by:

$$pV = 7.5 \times 10^6 \text{ Pa} \times 0.914 \text{ m}^3 = 7.3 \times 10^6 \text{ J}$$

The total number of uranium atoms in this volume is given by :

$$\text{Total number of atoms} = 1.9 \times 10^{21} \text{ atoms/cm}^3 \times 0.914 \times 10^6 \text{ cm}^3 = 1.7 \times 10^{27}$$

Since there are no other sources of energy, this energy must come in its totality from the electrical energy stored in the capacitor bank or electro-mechanical generator. In addition, there will be energy losses because of transfer to the plasma in the form of internal energy, Joule effect losses in the resistance of the coil and connecting leads, and other losses.

Therefore, it is necessary to make an assumption of the efficiency of energy transfer from electric to pV . For the purposes of this calculation, a conservative estimate of 50% efficiency is made. This means that the energy pV of 7.3×10^6 J must be multiplied by a factor of two, to obtain an

$$\text{Input Electrical Energy} = 1.5 \times 10^7 \text{ J}$$

[Note 1: Electrical and electro-mechanical systems with the capability of storing more than this energy are in existence today.

Note 2: Since these are only estimates or preliminary calculations, all values are generally rounded off to two significant digits.]

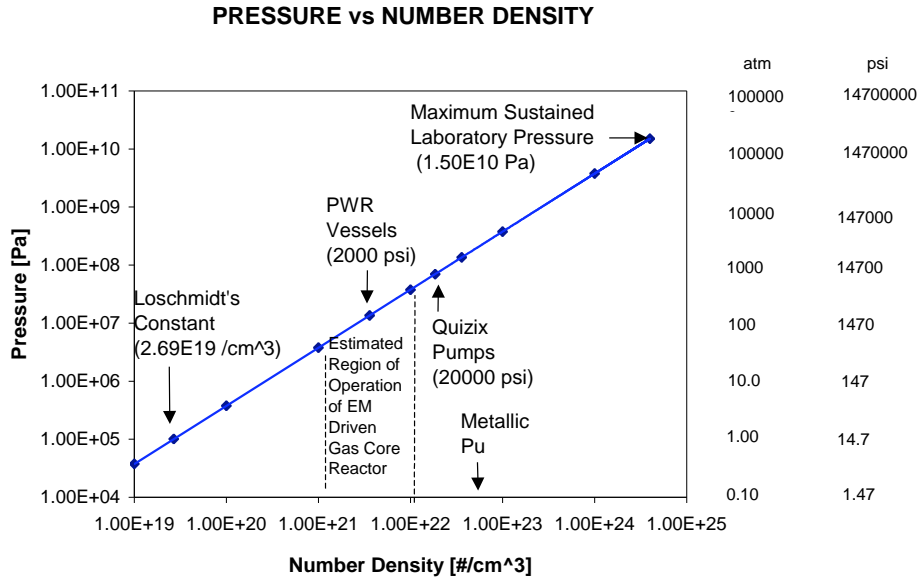

Figure 2 Pressure vs. number density

3 CALCULATION OF THE REQUIRED COIL CURRENT

The previous estimates and calculations have been performed for a typical short solenoid (essentially a ring) approximately two-meter in diameter. The inductance of a solenoid of these dimensions, as indicated in the graph shown in Figure 3, is shown to be approximately $L = 8 \mu\text{H}$.

The magnetic energy stored in an inductor is given by $E_B = \frac{1}{2} Li^2$. Therefore, the current required to store $1.5 \times 10^7 \text{ J}$ in the reactor coils is

$$i = [2 \times 1.5 \times 10^7 \text{ J} / (8 \times 10^{-6} \text{ H})]^{1/2} = 1.9 \times 10^6 \text{ A}$$

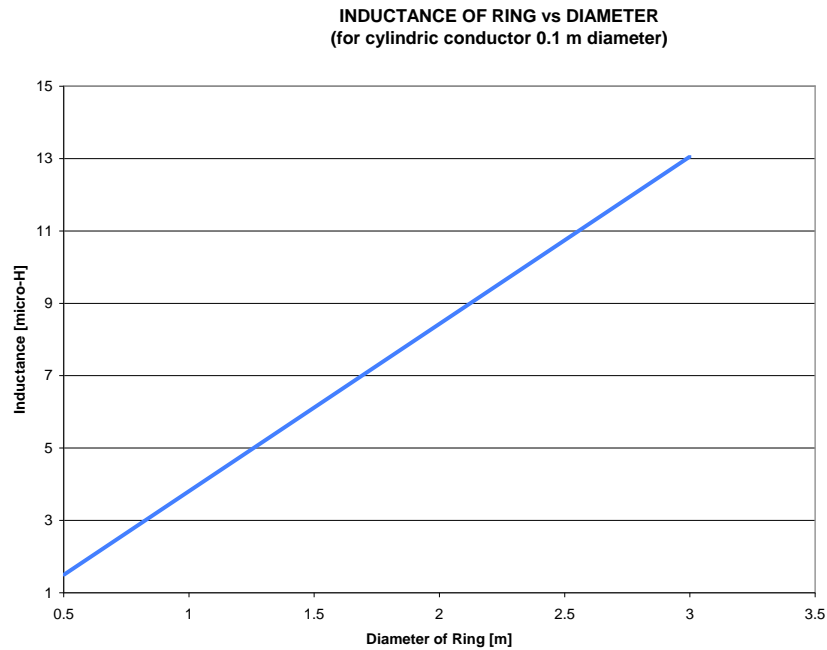

Figure 3 Inductance of a ring vs diameter

The required current in the coil can also be calculated from the magnetic pressure. As indicated before, a pressure of 7.5×10^6 Pa is required for criticality. This pressure results from the amplification of the pressure in the colliding shock waves. The amplification factor can vary over a wide range (approximately 10 to 10^6) depending on the dimensions of the shock tube, the rise-time of the magnetic field pulse, and other variables. A factor of 50 will be selected as the design goal, and this value will be used for these estimates. Therefore, the pressure in the original shock waves must be approximately 1.5×10^5 Pa.

To generate the required pressure to achieve criticality, it is necessary to apply a transverse magnetic field using a step function current (i.e., a current with infinitely short rise time) at the boundaries. The instantaneous magnetic field resulting from that current (B_0) will trigger a pressure pulse at the boundary which can be roughly estimated assuming equilibrium pressure balance given by $p = (B_0)^2/2\mu_0$ (J.P. Freidberg, "Ideal Magnetohydrodynamics", p. 91, H. Knoepfel, op.cit, p. 108). The boundary pressure as a function of the magnetic field has been calculated and plotted using these expressions. The corresponding graph is shown in Figure 4.

Generally such a pulse could undergo nonlinear steepening as it travels into the device and therefore its amplitude rises with distance. As a result the exact size of the pulse will be a complicated function of the initial current, its rise time, the state of the ambient gas (e.g., its γ , conductivity, ... etc) and the size of the device. Furthermore as the shocks collide since they carry magnetic fields of opposite polarity, their magnetic fields will annihilate and therefore result in the conversion of the magnetic into thermal energy and pressure. Therefore to estimate the exact size of the pressure at the shock collision region, MHD simulations will be needed taking all the above factors into account. These are extensively discussed in the accompanying modeling report.

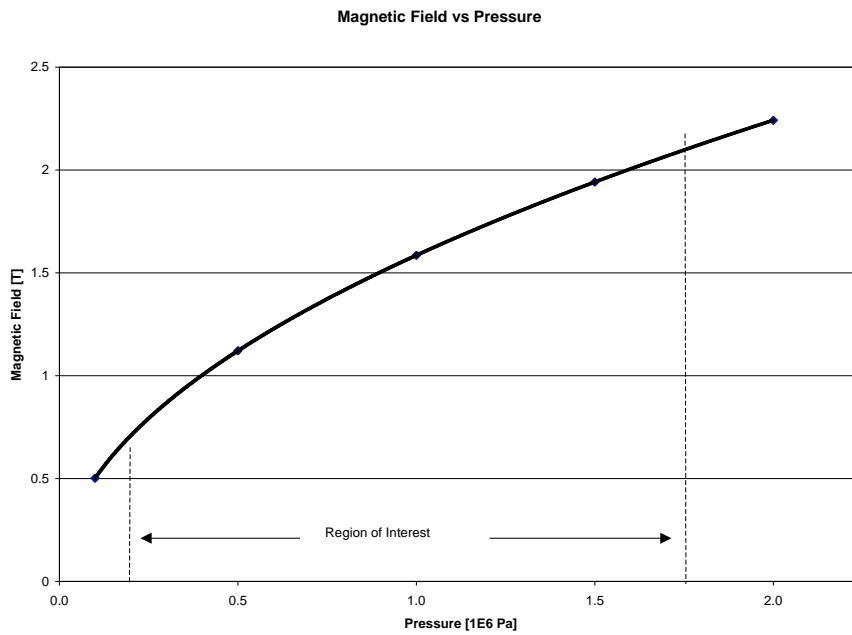

Figure 4 Magnetic field vs pressure

4 SHOCK GENERATION EXPERIMENTS

The PMI-GCR is a highly specialized pulsed magnetic field driven reactor with unique magnetohydrodynamic (MHD) and aeroacoustic characteristics. Therefore, the experimental aspect of this study should be initiated with the demonstration of pulsed magnetic field induced shock waves. Work performed during this study included electrodynamic and magnetohydrodynamic calculations to determine the magnetic field size and rise time for generation of the shock wave in a partially ionized plasma. Simulation results indicated that in gases with electrical conductivity (σ) in excess of 10 mho/m, magnetic field sizes of 10 Tesla or more with the rise time of less than one millisecond (compressor mode, see table 4 of the modeling report) or one microsecond (pulsed mode, see table 5 of the modeling report) are needed to achieve criticality. Building a test facility to produce the needed magnetic field may not be within the resources available for the proposed follow on work. Therefore, a critical task is to identify an existing facility that could be used to perform basic viability test for the PMI-GCR.

4.1 Diagnostic Tools

This report does not discuss the experimental methodology in detail. Most plasma diagnostic tools are available off the shelf. The series on shock waves and shock tubes outlines most of the state of the art experimental methods for gas kinetic shock studies.^[i,ii – iii]

4.2 Pulse Field Generators

Evaluation of user facilities at National High Magnet Laboratory (NHML) at Los Alamos National Laboratory (LANL) and other research facilities associated with NHML identified the following magnets with intensity and rise time characteristics that are needed for this project. Pulsed magnets at the NHML user facility at LANL fall into two general classes: non-destructive and destructive. The non-destructive pulsed magnets must solve the problem of the exceedingly high stresses generated in the magnet during pulsing. These stresses typically reach 200,000 pounds per square inch (equal to 1.4 Giga-Pascals), which is greater than the strength of most materials. As such, pulsed magnet technology relies on state of the art materials research. The most flexible pulsed magnets, from the point of view of the experimentalist, are “shaped-pulse” magnets in which the magnetic field shape can be specified to meet the particular needs of a given experiment. The 60 Tesla Long-Pulse magnet at Los Alamos is unique in the world for field volume and pulse shape.

Capacitor-driven

Field strength: 50-70 T, Period: 20-800 ms (available now at NHMFL).

AC power driven (Long-Pulse, adjustable pulse shape)

Field strength: 40-60 T, Period: 2 sec (>100 ms) (available now at NHMFL).

Capacitor + AC power

Field strength: 80-100 T, Period: 20 ms (in design/construction stage at NHMFL).

Destructive pulsed magnets

These avoid the strength of materials problem and are designed to explode with every pulse. Since the intense magnetic field exists only as long as it takes a shock-wave to propagate through the magnet the pulse duration is limited to a few microseconds. The highest magnetic fields are achieved by explosively compressing the magnetic field into the sample (although the sample is destroyed with each pulse!)

Single turn coil (capacitor-driven)

Field strength: 100-250 T, Period: 4-8 microsecond (available at ISSP, University of Tokyo and Humboldt University, Berlin).

“Strip generator” (chemical + capacitor)

Field strength: 100-250 T, Period: 5-10 microsecond (available at LANL through collaboration and external funding).

“Imploding liner” (capacitor)

Field strength: 400-550 T, Period: 4-8 microsecond (being developed for programs in high energy density physics at LANL, also available at ISSP, University of Tokyo).

Multi-stage generator (chemical + capacitor)

Field strength: 1000 T plus, Period: 4-8 microsecond (available at LANL through collaboration and external funding, also available at Sarov, Russia).

Non-destructive 100 T magnet

This magnet, now in the design phase, is a joint project between the National Science Foundation (through the NHMFL) and the US Department of Energy. It will produce 100 T pulses in a re-usable magnet for periods of milliseconds, which is approximately two thousand times longer than is presently available at this field level.

60 T capacitor-driven pulsed magnet

This fiber glass reinforced magnet has a bore diameter of 14 mm at 77 K and an overall pulse width of about 20 ms. Those users willing to risk earlier magnet failure can be provided fields above 60 T. The following sample environment and probes are available:

- ^4He Cryostat ($1.5\text{K} < T < 4\text{K}$); sample space: 7.5 mm
- Magnetization coils

50 T Magnet

This magnet (Figure 5) has bore diameters of 24 mm at 77 K and an overall pulse width of about 20 ms. The design follows Professor Fritz Herlach's prescription (Leuven, Belgium) of using a variable thickness of fiber glass reinforcement between each layer of conductor to uniformly distribute the full-field mechanical hoop stress. Following 500 to 700 pulses the conductor breaks somewhere due to mechanical fatigue. The lifetime of the magnets is shortened by pulsing at higher fields. Those users willing to risk earlier magnet failure can be provided fields of 53-54 T. The following sample environment and probes are available:

- ^4He Cryostat
- Flow Cryostat ($1.5\text{K} < T < 320\text{K}$); sample space: 9.5 mm
- ^3He System (350 mK base temp.); sample space: 9.5 mm
- Dil. Fridge (30 mK base temp.); sample space: 8 mm
- de Haas-van Alphen; sample space: 3 x 1 mm
- Magnetization; sample space: 3 x 1 mm
- 1 hour cool-down time between pulses

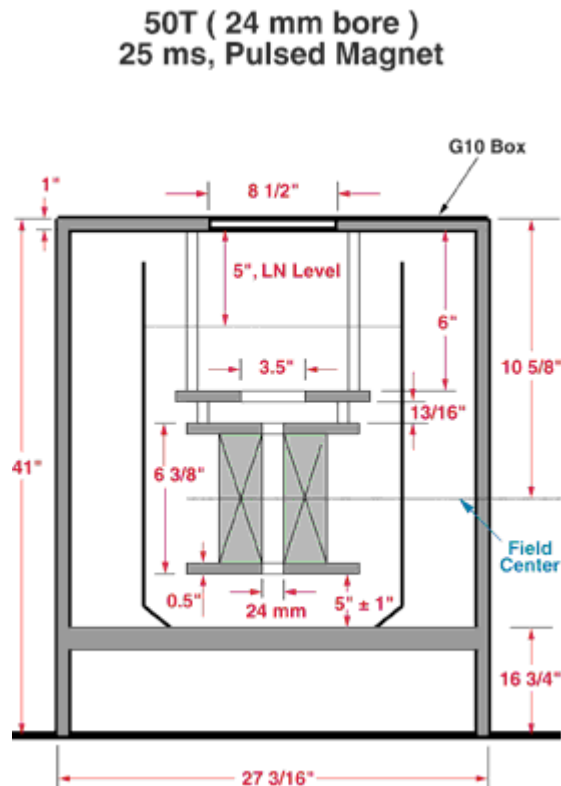

Figure 5 The 50 T Magnet schematic

20 T Magnet

The 20 T magnet serves an essential role in a pulsed field laboratory by providing calibration, set-up, and staging services in addition to a low cost and convenient field environment for dedicated experiments. The following sample environment and probes are available:

- Flow cryostat ($1.5\text{K} < T < 320\text{K}$); sample space: 40 mm in gas and 2 mm in vacuum
- Magnetization - Vibrating Sample Magnetometer ($1.8\text{K} < T < 320\text{K}$); sample space: mm
- Dilution refrigerator (20 mK base temp.); sample space: 32 mm in vacuum and 1 mm in liquid
- High temperature probe ($4\text{K} < T < 600\text{K}$)
- Compensation coil for thermometry in a low field of 1500 gauss and experiments in a field high gradient of 6000 gauss/mm)
- Critical current probe, 300 A, 4 K
- Magnetostriction cell, 1×10^{-9} DL/L, $25\text{ mK} < T < 300\text{ K}$

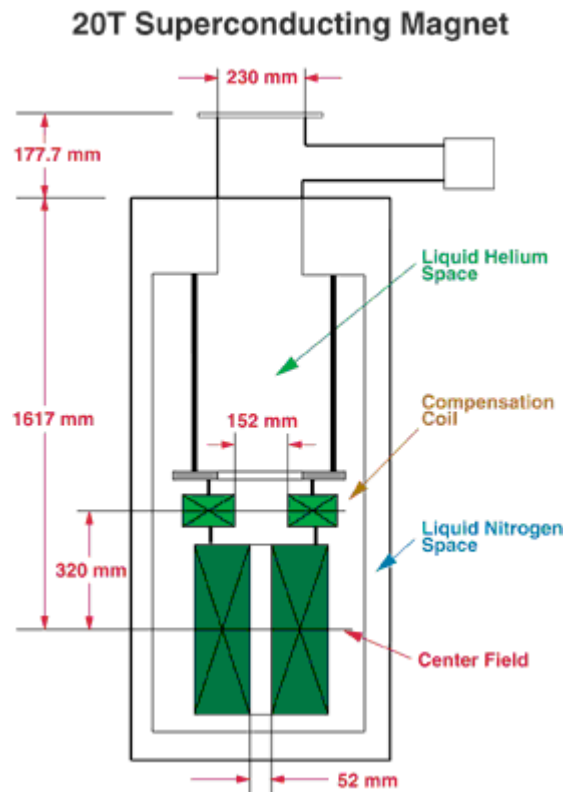

Figure 6 Schematic of the 20 T Superconducting magnet

40 T Magnet

This magnet has a bore diameter of 24 mm at 77 K and an overall pulse width of about 500 ms. It was designed with outer steel shell reinforcement in the manner of the long-pulse magnets of France High Magnet Lab (Toulouse, France). The following sample environment and probes are available:

- He-4 cryostat
- Flow Cryostat ($1.5\text{K} < T < 320\text{K}$); sample space: 9.5 mm
- ^3He System (350 mK base temp.); sample space: 9.5 mm
- de Haas-van Alphen; sample space: 3 x 1 mm

- Magnetization; sample space: 3 x 1 mm
- 80 minute cool-down time between pulses

**40T (24 mm bore)
600 ms, Pulsed Magnet**

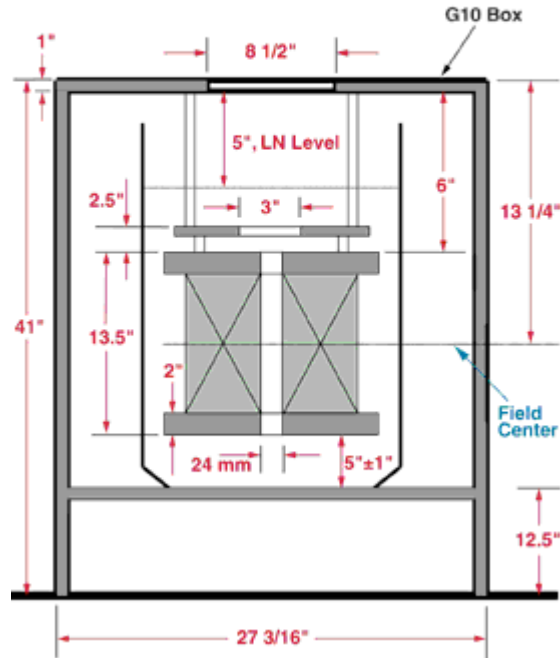

Figure 7 Schematic of the 40 T pulsed magnet

To demonstrate the viability of the intense shock wave generation using pulsed magnetic field, 100 Tesla magnet (non-destructive) at NHML-LANL is the ideal one. This magnet is a joint project between the National Science Foundation (through the NHMFL) and the US Department of Energy and has not been completed.

Progress has been made in designing an alternative experiment that requires more modest magnetic fields (~10 to 40 Tesla). The alternative experiment will use a conductive (metallic) circular plate and a planar electromagnetic generator to generate a pressure wave with characteristics needed for the PMI-GCR. The schematic illustration is shown in Figure 8. This is similar to the unit currently operated in Schneider Labs discussed below.

Two shock generation methods were studied in the preliminary computer simulations. One method assumed that a magnetoplasmadynamic thruster could be converted into a transient shock generator (MPD compressor). Two such converted thrusters placed at opposite ends of a shock tube would create the shock collision in the center of the tube. Pumps would maintain positive ambient pressure behind the MPD compressors by supplying make-up gas fuel as the compressors force gas into the shock tube from the tube end boundaries. In this method, the shock waves would build up slowly as MHD waves build up into a well-formed shock over a few or some fraction of a millisecond. At this time there are no plans for experiments based upon this method.

A second method assumes that a high-pulsed magnetic field applied at the boundaries of the shock tube, if correctly configured, could provide enough magnetic pressure to create strong shock waves or pressure pulses (density waves) in the gas fuel. To do this the gas would have to be ionized and highly conductive at the boundaries, which could be achieved by an electrical discharge through the gas. The rise time for the magnetic pulse might be 1 to 10 microseconds in this case depending upon the speed of delivery of current to the solenoids, during which time a spark discharge would be required to keep the gas sufficiently ionized for maximum effectiveness.

An experiment to measure the impact of pulsed electromagnetic fields on gas filled tubes could be conducted by utilizing existing facilities at Schneider Laboratories in Alachua, Florida^[iv]. Pulsed electromagnetic fields can be generated at the Schneider Lab, and with minimal effort diagnostic instruments can be set up to measure the characteristics of shock waves generated in nearby gas shock tubes. The Schneider antenna allows controlling the shape of the electromagnetic pulse by innovative implementation of a spark gap in a pancake shape spiral coil coupled to a high voltage capacitor discharge bank. This is an ultra fast means of current and its associated magnetic field interruption. Because the Schneider Lab system uses electric and magnetic fields to extinguish fires it is also capable of providing both the ionizing power and the magnetic pressure pulse in a single integrated pulse field delivery system necessary for small scale shock tube research. The existing generator unit consists of a high voltage capacitor (4 μ F, 15 kV), high voltage power supply, igniter unit, power transfer system, and antenna coil (disk coil). The pancake shape antenna coil has an associated magnetic field pointing along its axis. The power transfer system comprises a full wave rectifier, the power transfer bus bars, and the main spark gap. There also exist a second gap in the antenna coil which is created manually by a cut a certain location of the coil to be discussed below. We will refer to the two gaps as the main and the coil gaps respectively.

The power to be transferred from the capacitor is delivered via bus bars to the antenna coil that radiates the generated electromagnetic pulse (EM pulse). In order to generate an electromagnetic pulse, the energy needs to also be stored periodically in the capacitor and released as fast as possible. The main spark gap does function as a fast switch appropriate to the high voltage and current resulting from the high voltage capacitor discharge.

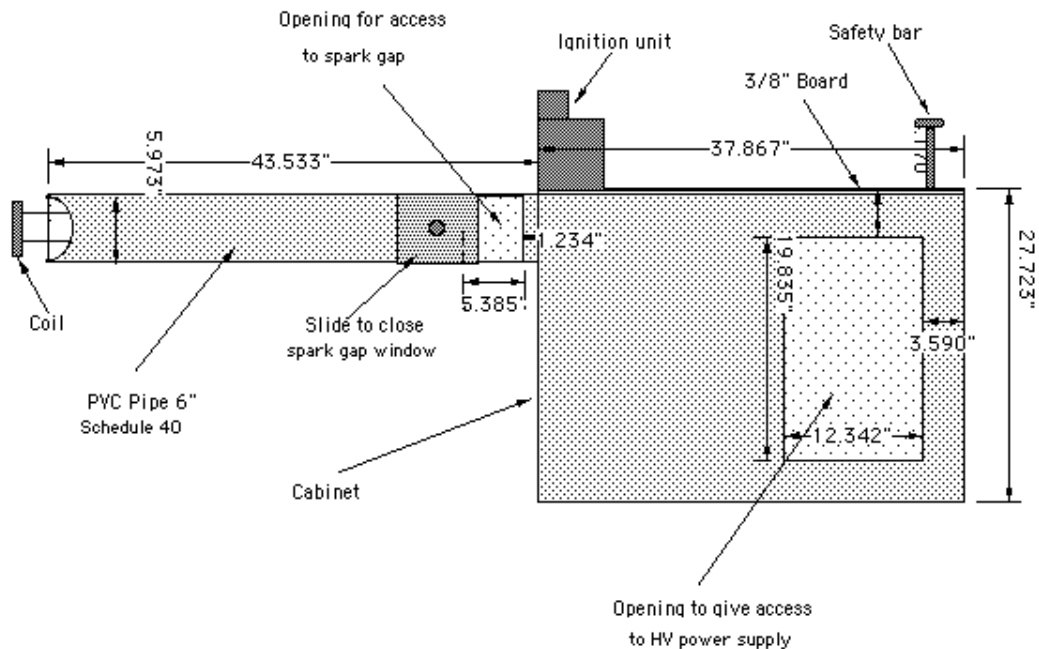

Figure 8 Existing unit for generation of high field EM pulses

The spark gap is currently designed to deliver short pulses over relatively long distances; this would be modified to pack more energy into a smaller volume for the shock tube experiments. One can control the inductance of the spark gap by the area of the plates of the gap as well as their distance. The inductance of the spark gap in turn does control the rise time of the current resulting from the capacitor discharge. That is, the area between these two is proportional to the logarithm of the inductance to which these currents are exposed. Low main spark gap inductance is important to achieve short rise times and, therefore, high power pulses.

But these remedies may not yield the powers desired as Schneider laboratory experienced in the case of the fire extinguishment applications. That is the current and its associated magnetic field rise time did not create emf strong enough for their applications. Schneider therefore devised the following solution. He manually engineered cutting the continuous wire comprising the pancake shape antenna coil at its third channel. This generated a much larger emf by forcing a rapid fall of the current and its associated magnetic field by ejecting the arc in the gap by its pondomotive force $J \times B$; i.e., this yielded considerably larger emf than the original emf due to the rise time. This current fall following the original rise enabled control of the pulse shape too and did generate much greater power.

The main spark gap is triggered by an ignition unit capable of about 30 kV, it remains to be seen whether this setup would be capable of MHD shock pulse formation in a heated gas, any adjustments and ramping up of the power supply would be sub-experiments performed prior to the main study.

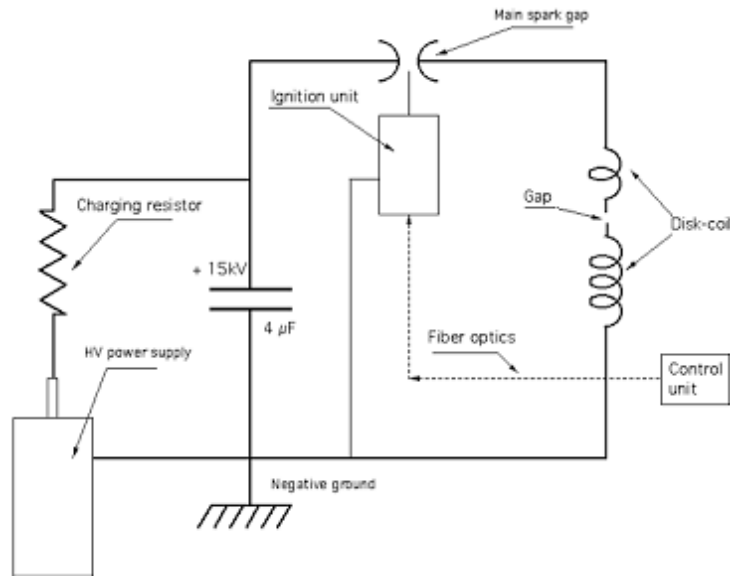

Figure 9 Schematic of the circuit diagram for the EM pulse generator device of Figure 8

5 SHOCK COLLISION EXPERIMENTS

Experiments on shock collision will be scaled down to dimensions commensurate with existing shock tube facilities. This will mean that large bore shock tubes as envisaged for the PMI-GCR reactor proper probably cannot be studied directly. The scaling up to full size is however not necessary to gather valuable data on the characteristics of shock interaction in high-pressure shock tubes. The scaling up is only necessary if fission power generation effects are desired, which is not within the scope of the presently conceived experimental program. The more important task is to gather experimental data for validating computer models, the computer simulations can then use this data to go back and make necessary modifications, including adding fission heating source terms. So the shock collision experiments can be useful even with “non-nuclear” conditions.

Two experiments are planned to investigate shock collisions. The first experiment would depend upon the success of the Schneider Lab shock generation experiments. If those experiments outlined above are capable of producing strong shocks, then two such generators can be used to form two incident shocks at opposing ends of a single shock tube. Their collision can then be studied in the laboratory. The actual shock tube can even be sealed-off from the EM pulse coil itself as long as the ends of the shock tube allow sufficient energy to be delivered to the gas inside the shock tube. The exact arrangement would have to constitute a series of sub-experiments performed on-site because the shock tube application for these pulse field.

A second experiment would dispense with electromagnetic shock generation and instead use either explosives (or bursting diaphragms) to generate the shock waves. The collision can then be guaranteed and studied in a controlled manner. By rupturing diaphragms that initially separate high pressure driver gas from low pressure test gas shocks are guaranteed, but if high pressure test gas is used the resulting shocks may be weak and may dissipate rapidly before a collision of two incident shocks can be formed. Linear wave superposition would then be the only effect. Thus, it may be necessary to look at using small explosive charges to generate stronger shocks, guaranteeing ionizing shock wave structure and consequently producing the MHD effects seen in computer simulations. Using explosives also allows both high pressure and high temperature test gas to be used, thus allowing partial plasma conditions more or less throughout the shock tube, or to the extent desired within practical limits. However, such measures would be only necessary if adequate shocks for studying the effects of high pressure shock tube kinematics cannot be formed with existing electromagnetic pulse methods, the former therefore constitute an experimental last resort.

6 FUEL AND MATERIAL PROPERTY EXPERIMENTS

At the present state of conception, the PMI-GCR system can be studied to the desired accuracy using existing databases and knowledge of weakly ionized gas properties. However, at a future date it will be more critical to know properties, particularly electrical conductivity and radiation loss coefficients, more accurately. Therefore, experimental plan may also be undertaken to begin setting up a laboratory for the study of transport properties of partial plasmas in UF_4 gas mixtures.

Tables of thermodynamic properties^{[v],[vi],[vii]} for UF_n and UF_n^* ($n=0,\dots,6$) exist up to about 10 000°K, but above 4000°K most of the tabulated data is either extrapolated from lower temperature measurements or is entirely theoretical. Computer models of the PMI-GCR system currently use ideal gas properties, constant electrical conductivity and zero viscosity and thermal conductivity. Transport properties for $UF_n-UF_n^*$ systems have also been tabulated or calculated^{[vii],[viii]} but as with the thermodynamic properties these are well known only for the pure species and only for temperatures below about 4000°K. Limited modeling has also been performed on fissioning gas thermoproperties, mainly focusing on electrical conductivity.^[ix]

Computer simulations of PMI-GCR designs could be continued fruitfully without additional thermophysical property data, however, at some stage the viability of this highly nonlinear dynamical reactor concept may hinge upon the impact of fissioning gas energetics on the transport properties of the gas mixture. These need to be measured in order to validate (or correct as the case may be) the gas mixture properties to at least attempt to model real gas effects. In particular, published data on fission product ionization and enhancement of electrical conductivity on partially ionized gases is scarce and existing computer models are of dubious validity in the highly non-equilibrium system of a shock tube. Even limited experimental data elucidating U-F-e⁻-ion mixture properties under shock-heated conditions would therefore be valuable for refinement of the numerical simulations of the shock flow.

References

-
- [i] D. Bershader, and R. Hanson, “Shock Waves and Shock Tubes”, *Proceedings of the 15th International Symposium on Shock waves and Shock Tubes*, Berkeley, CA, 28 July–2 August, 1985, Stanford University Press, CA, 1986.
 - [ii] B. Ahlborn, A. Hertzberg, D. Russell, (Eds.) “Shock Tube and Shock Wave Research”, *Proceedings of the 11th International Symposium on Shock Tubes and Shock Waves*, Seattle, 11-14 July, 1977, University of Washington Press, Seattle, 1977.
 - [iii] R. Brun, L.Z. Dumitrescu (eds.), “Hypersonics, Shock Tube and Shock Tunnel Flow”, *Proceedings of the 19th International Symposium on Shock Waves*, Marseille, France, 26-30 July 1993.
 - [iv] R.T. Schneider, R.J. Hirko, J.D. Cox, and N.H. Weinstein, (Private Communication) “Final Report for Phase II: Fire Extinguishment by Electro-Magnetic Fields”, Schneider Laboratories, Ltd., Alachua, FL, July 2000.
 - [v] I. Barin and G. Platzki, “Thermochemical Data of Pure Substances”, Third Edition, Volume II, VCH Publishers, New York, 1995.
 - [vi] L.V. Gurvich, *et al.*, “Thermodynamic Properties of the Uranium-Fluorine Gaseous System”, Preprint 1-0018, IVTAN, Moscow, 1977.
 - [vii] B.J. McBride, and S. Gordon, “Computer Program for Calculation of Complex Chemical Equilibrium Compositions and Applications”, NASA Reference Publication 1311, June 1996, Volume I. Analysis, Volume II. Users Manual and Program Description, 1996.
 - [viii] Y. Watanabe, and S. Anghaie, “Thermophysical Properties of as Phase Uranium Tetrafluoride”, **AIAA-93-2758**, *Proceedings of the 28th AIAA Thermophysics Conference*, Orlando, FL, 6-9 July, 1993.
 - [ix] Y. Watanabe, J. Appelbaum, I. Maya, “Electrical Conductivity of UF₄-K₂UF₆ Gas Partially Ionized by Fission Fragments”, *Nuclear Science & Engineering*, **110**, p109-127, 1992.

REPORT DOCUMENTATION PAGE

Form Approved
OMB No. 0704-0188

Public reporting burden for this collection of information is estimated to average 1 hour per response, including the time for reviewing instructions, searching existing data sources, gathering and maintaining the data needed, and completing and reviewing the collection of information. Send comments regarding this burden estimate or any other aspect of this collection of information, including suggestions for reducing this burden, to Washington Headquarters Services, Directorate for Information Operation and Reports, 1215 Jefferson Davis Highway, Suite 1204, Arlington, VA 22202-4302, and to the Office of Management and Budget, Paperwork Reduction Project (0704-0188), Washington, DC 20503

1. AGENCY USE ONLY (Leave Blank)	2. REPORT DATE June 2008	3. REPORT TYPE AND DATES COVERED Contractor Report	
4. TITLE AND SUBTITLE Experimental Plans for Subsystems of a Shock Wave Driven Gas Core Reactor			5. FUNDING NUMBERS NCC8-225
6. AUTHORS F. Kazeminezhad* and S. Anghai**			
7. PERFORMING ORGANIZATION NAME(S) AND ADDRESS(ES) *Institute for Scientific Research 320 Adams Street Fairmont, WV 26555-2720		8. PERFORMING ORGANIZATION REPORT NUMBER M-1232	
		9. SPONSORING/MONITORING AGENCY NAME(S) AND ADDRESS(ES) National Aeronautics and Space Administration Washington, DC 20546-0001	
		10. SPONSORING/MONITORING AGENCY REPORT NUMBER NASA/CR-2008-215412	
11. SUPPLEMENTARY NOTES Prepared for the Vehicle Systems Engineering and Control Branch, Engineering Directorate Technical Monitor: John Cole			
12a. DISTRIBUTION/AVAILABILITY STATEMENT Unclassified-Unlimited Subject Category 20 Availability: NASA CASI 301-621-0390			12b. DISTRIBUTION CODE
13. ABSTRACT (Maximum 200 words) This Contractor Report proposes a number of plans for experiments on subsystems of a shock wave driven pulsed magnetic induction gas core reactor (PMI-GCR, or PMD-GCR pulsed magnet driven gas core reactor). Computer models of shock generation and collision in a large-scale PMI-GCR shock tube have been performed. Based upon the simulation results a number of issues arose that can only be addressed adequately by capturing experimental data on high pressure (~1 atmosphere or greater) partial plasma shock wave effects in large bore shock tubes (ε10 cm radius). There are three main subsystems that are of immediate interest (for appraisal of the concept viability). These are (1) the shock generation in a high pressure gas using either a plasma thruster or pulsed high magnetic field, (2) collision of MHD or gas dynamic shocks, their interaction time, and collision pile-up region thickness, and (3) magnetic flux compression power generation (not included here).			
14. SUBJECT TERMS propulsion, power, nuclear, gas corereactor, magnetohydrodynamics, colliding shocks			15. NUMBER OF PAGES 24
			16. PRICE CODE
17. SECURITY CLASSIFICATION OF REPORT Unclassified	18. SECURITY CLASSIFICATION OF THIS PAGE Unclassified	19. SECURITY CLASSIFICATION OF ABSTRACT Unclassified	20. LIMITATION OF ABSTRACT Unlimited

National Aeronautics and
Space Administration
IS20

George C. Marshall Space Flight Center
Marshall Space Flight Center, Alabama
35812