

US007837913B2

(12) **United States Patent**  
**Sakamoto et al.**(10) **Patent No.:** **US 7,837,913 B2**(45) **Date of Patent:** **Nov. 23, 2010**(54) **HIGH ASPECT RATIO TEMPLATE AND METHOD FOR PRODUCING SAME**(75) Inventors: **Jeff S. Sakamoto**, San Gabriel, CA (US); **James R. Weiss**, Pasadena, CA (US); **Jean-Pierre Fleurial**, Altadena, CA (US); **Adam Kisor**, Burbank, CA (US); **Mark Tuszynski**, La Jolla, CA (US); **Shula Stokols**, La Jolla, CA (US); **Todd Edward Holt**, Vancouver, WA (US); **David James Welker**, Vancouver, WA (US); **Christopher David Breckon**, Ruston, WA (US)(73) Assignee: **California Institute of Technology**, Pasadena, CA (US)

(\*) Notice: Subject to any disclaimer, the term of this patent is extended or adjusted under 35 U.S.C. 154(b) by 1470 days.

(21) Appl. No.: **11/200,982**(22) Filed: **Aug. 10, 2005**(65) **Prior Publication Data**

US 2010/0055144 A1 Mar. 4, 2010

**Related U.S. Application Data**

(60) Provisional application No. 60/600,454, filed on Aug. 11, 2004, provisional application No. 60/639,462, filed on Dec. 28, 2004, provisional application No. 60/680,435, filed on May 12, 2005.

(51) **Int. Cl.****B29B 17/00** (2006.01)**B29B 44/04** (2006.01)**B01D 24/00** (2006.01)(52) **U.S. Cl.** ..... **264/48**; 264/344; 264/49; 210/508; 210/505; 424/423; 424/93.7; 428/357; 428/311.51; 623/1.49; 977/896(58) **Field of Classification Search** ..... 210/508, 210/509; 264/172.13, 344, 299, 317, 48, 264/49, 219; 428/357, 311.51; 424/93.7, 424/423; 623/22, 16, 23, 116, 118, 1.49, 623/22.11; 521/61; 977/896  
See application file for complete search history.(56) **References Cited**

## U.S. PATENT DOCUMENTS

5,856,367 A \* 1/1999 Barrows et al. .... 521/64

(Continued)

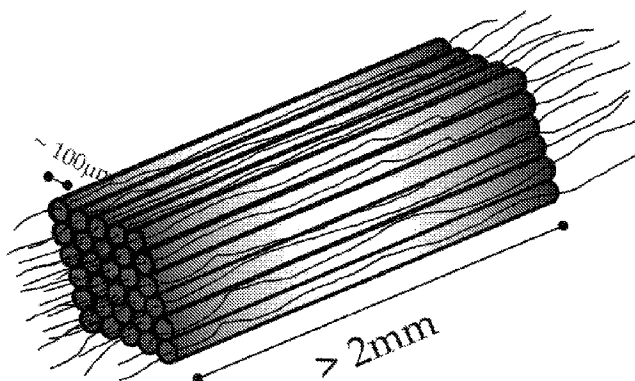
## OTHER PUBLICATIONS

Berry, A. D., et al., Fabrication of GaAs and InAs wires in nanochannel glass, Appl. Phys. Lett. 69(10):2846-2848 (1996).

(Continued)

*Primary Examiner*—Ana M Fortuna(74) *Attorney, Agent, or Firm*—Seth D. Levy; Davis Wright Tremaine LLP(57) **ABSTRACT**

Millimeter to nano-scale structures manufactured using a multi-component polymer fiber matrix are disclosed. The use of dissimilar polymers allows the selective dissolution of the polymers at various stages of the manufacturing process. In one application, biocompatible matrixes may be formed with long pore length and small pore size. The manufacturing process begins with a first polymer fiber arranged in a matrix formed by a second polymer fiber. End caps may be attached to provide structural support and the polymer fiber matrix selectively dissolved away leaving only the long polymer fibers. These may be exposed to another product, such as a biocompatible gel to form a biocompatible matrix. The polymer fibers may then be selectively dissolved leaving only a biocompatible gel scaffold with the pores formed by the dissolved polymer fibers.

**21 Claims, 9 Drawing Sheets**

U.S. PATENT DOCUMENTS

6,231,605 B1 \* 5/2001 Ku ..... 623/11.11  
 6,534,084 B1 \* 3/2003 Vyakarnam et al. .... 424/443  
 6,673,285 B2 \* 1/2004 Ma ..... 264/49  
 6,921,508 B2 \* 7/2005 Latini et al. .... 264/172.13  
 7,087,200 B2 \* 8/2006 Taboas et al. .... 264/49  
 7,270,813 B2 \* 9/2007 Shimp et al. .... 424/93.7  
 7,431,869 B2 \* 10/2008 Haggard et al. .... 264/29.2  
 7,575,759 B2 \* 8/2009 Murphy et al. .... 424/423  
 7,670,797 B2 \* 3/2010 Vacanti et al. .... 435/30  
 2009/0202605 A1 \* 8/2009 Sakamoto et al. .... 424/423

OTHER PUBLICATIONS

Martin-Gonzalez, M., et al., Direct Electrodeposition of Highly dense 50 nm Bi<sub>2</sub>Te<sub>3-y</sub>Se<sub>y</sub> Nanowire Arrays, Nano Letters, 3(7):973-977 (2003).  
 Penner, R.M., et al., Preparation and Electrochemical Characterization of Ultramicroelectrode Ensembles, Anal. Chem. 59:2625-2630 (1987).  
 Thurn-Albrecht, T., et al., Ultrahigh-Density Nanowire Arrays Grown in Self-Assembled Diblock Copolymer Templates, Science, 209:2126-2129 (2000).

\* cited by examiner

Figure 1

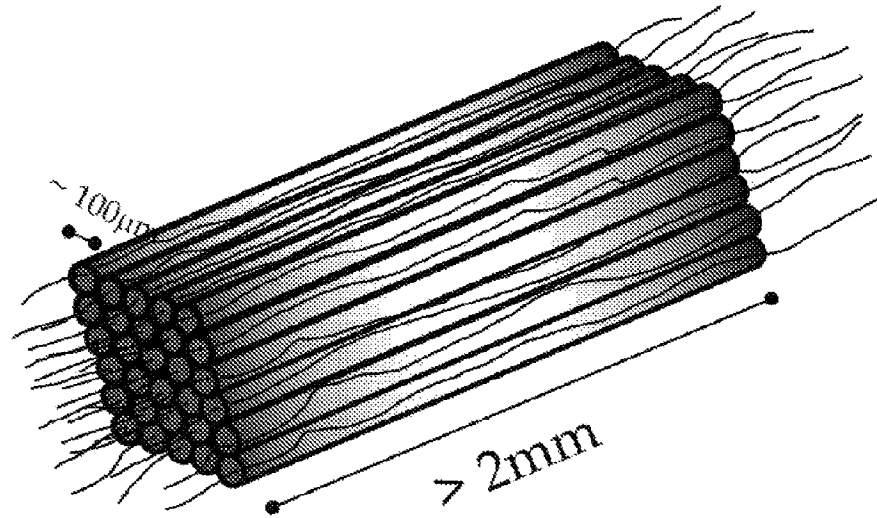
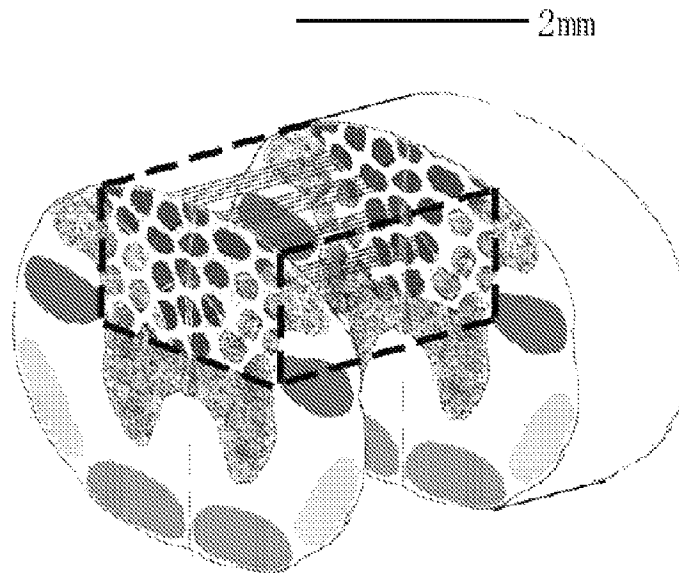
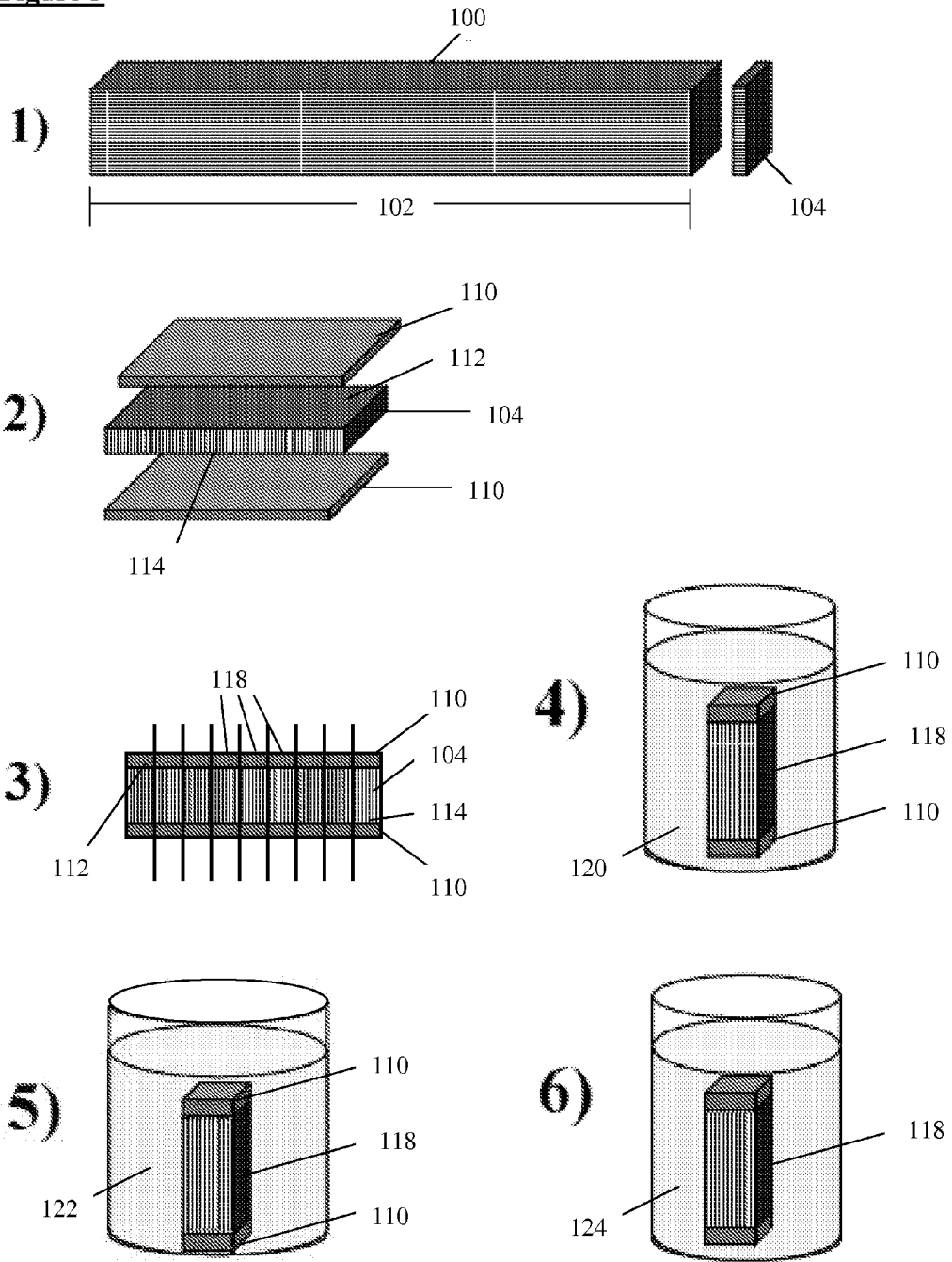


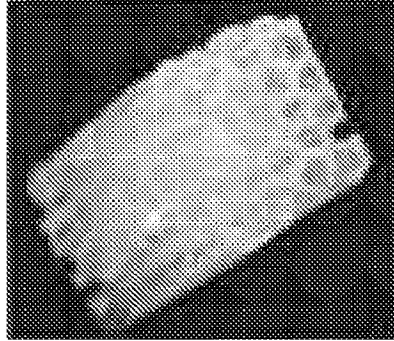
Figure 2



**Figure 3**

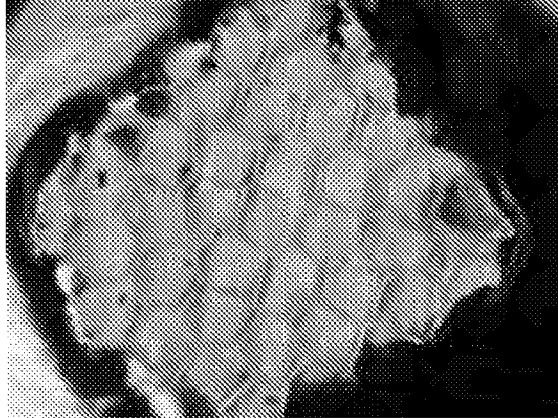


**Figure 4**

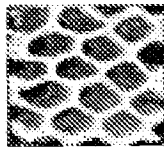


**Figure 5**

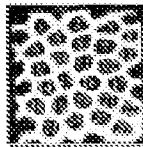
A



B

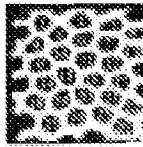


C



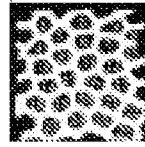
0.5mm

D



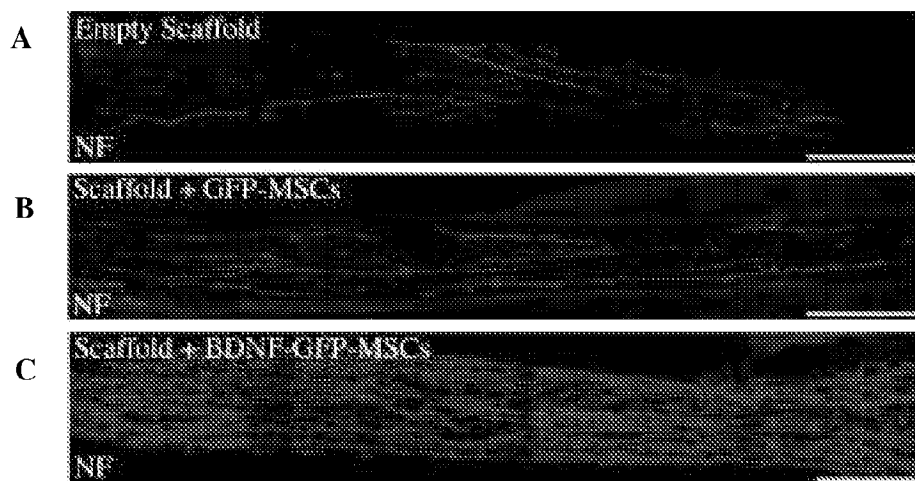
1.0mm

E

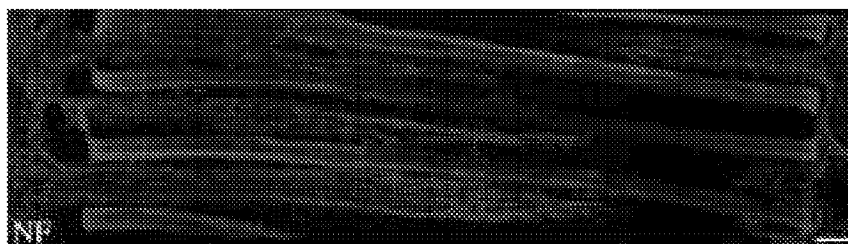


1.5mm

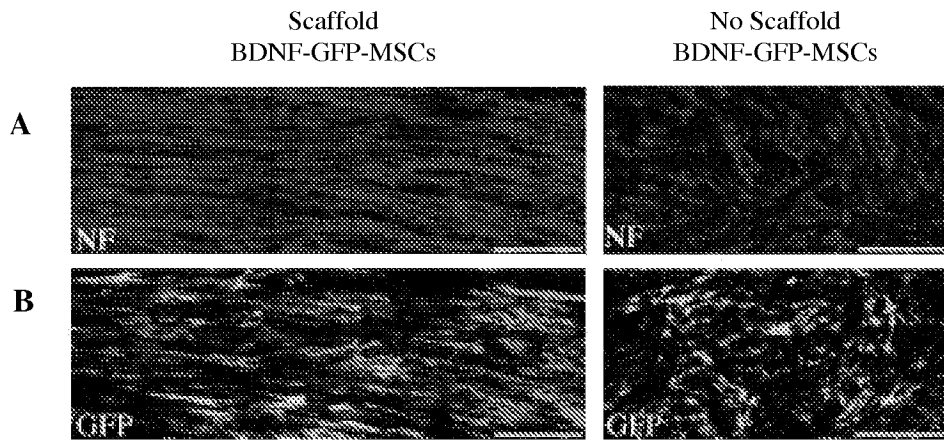
**Figure 6**



**Figure 7**



**Figure 8**



**Figure 9**

