

DRAFT 7/5/2000

Source of Acquisition
NASA Johnson Space Center

Inflatable Structures Technology Handbook

Chapter 21 Inflatable Habitats

Kriss J. Kennedy, Space Architect
NASA Johnson Space Center

Jasen Raboin, Aerospace Engineer
NASA Johnson Space Center

Gary Spexarth, Aerospace Engineer
NASA Johnson Space Center

Gerard Valle, Aerospace Engineer
NASA Johnson Space Center

1.0 Introduction To Habitat Systems

The idea of fabric inflatables has been around for many years and the applications for them are numerous. Inflatables ranging from hot air balloons and air ships to structural air beams and space suits, all present interesting design challenges. However, when these design challenges are met, inflatables often perform a function that would be difficult, if not impossible to achieve with stiff metallic or composite structures. Whether the need is to have a module with a working volume larger than your launch vehicle or a space suit that must be flexible while under pressure, fabric inflatables provide a design avenue to create structures that fulfill these needs.

One of the latest design challenges comes from the need to work, live, and travel in space for long periods of time. The large volume needed to live in space is not

only used to store the vast equipment and supplies needed to sustain life, but also to provide important psychological benefits for the crew. Creating a structure capable of sustaining life in the harsh environment of space is a major design challenge in itself. But when that fully integrated structure needs to be larger than the volumetric payload capacity of conventional launch vehicles, fabric inflatable modules provide an attractive alternative to metallic structures.

There are many design challenges involved in developing a large fabric structure in space. The first is to create the structure itself, which must be able to withstand the extremely high loads due to the size and internal pressure. The second is to be able to protect that structure from the harsh environment of space in terms of micrometeoroids, extreme thermal variances, radiation, and atomic oxygen. All these systems need to work in concert with one another.

The remainder of this chapter focuses on a design concept called TransHab, a lightweight inflatable structure originally envisioned as a Mars transit vehicle. TransHab, short for 'Transit Habitation Vehicle', would provide the large volume necessary to make such long duration journeys. TransHab consists of a lightweight aluminum and graphite-composite core, 3.35 meters (11 feet) diameter by 10.97 meters (36 feet) tall, surrounded by a 8.23 meter (27-foot) diameter inflatable shell. TransHab's inflatable shell has the ability to be folded for launch and then deployed on orbit. Therefore, TransHab can provide more than three times the volume and storage space, compared to traditional

aluminum modules for around the same cost and mass. The TransHab fabric shell has separate functional layers that provide a low permeable gas barrier, a structural pressure shell, a thermal control system, and micrometeoroid, atomic oxygen, and radiation protection.

During the development of a full-scale inflatable structure, the benefits of the module (larger volume, more storage, additional radiation protection, etc...) became more apparent and appealing as a candidate for the habitation module on the International Space Station (ISS). The following sections (1) utilize the proposed ISS TransHab as an example of a large scale inflatable structure, (2) provide an overview of the ISS inflatable habitation module concept, and (3) describe how the TransHab team approached the many design challenges to create the first proven large-scale inflatable crew habitation module for use in space.

2.0 Transhab Architecture

TransHab is a habitation module designed to support a six-member crew for long duration stays in space. It was originally designed to support a Mars mission, but has since been modified to support ISS habitation needs. It functionally provides facilities for sleeping, eating, cooking, personal hygiene, exercise, entertainment, storage, and a radiation storm shelter. A partial list of requirements derived for the TransHab inflatable module to provide is listed below.

- Individual private crew quarters for six crew.
- A Galley / Wardroom.
- A Crew Health Care System.
- Personal hygiene facilities.
- Personal and general storage.
- 300+ cubic meters (10,594+ cubic feet) of pressurized volume.
- Internal pressure of 760 torrs (14.7 psia).
- Launch in the Space Shuttle.
- Two earth-viewing windows.
- Secondary structure to support equipment and human systems.
- Environmental Control and Life Support: air distribution and collection, water and thermal conditioning.
- Communications: human to human, human to machine/system.
- Command and data handling.
- Transition space (tunnel/ vestibule) for crew and equipment into ISS.
- Lighting: 30 fc.
- External structural interface to other pressurized modules (ISS).
- External utility interfaces to ISS, i.e. power, communications, data, air, water, waste, gas, thermal, etc..
- Robotic system interfaces (grapple fixture) to remove TransHab from Orbiter payload bay and place on ISS.

- Survive 10 years in space environment, i.e. radiation, atomic oxygen, thermal / UV, micrometeoroid and orbital debris, etc.

The ISS TransHab is divided into four functional levels within its pressurized volume (Figure 1 and 2).

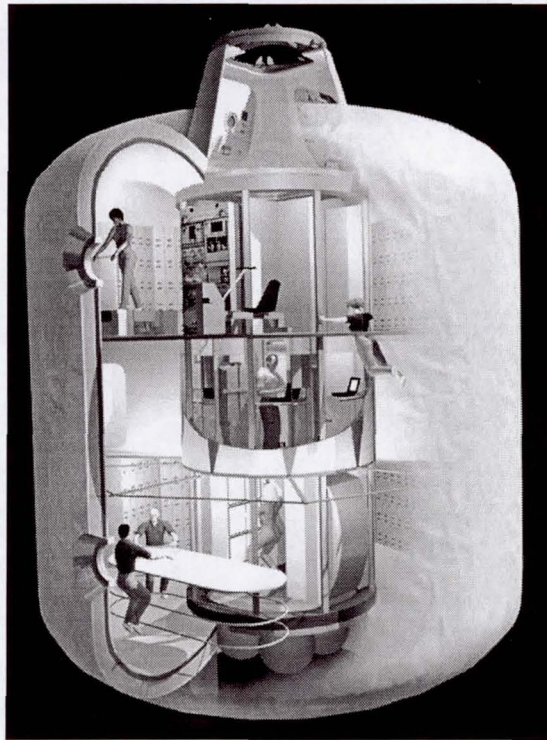

Figure 1. ISS TransHab Internal View, NASA JSC S99-05363

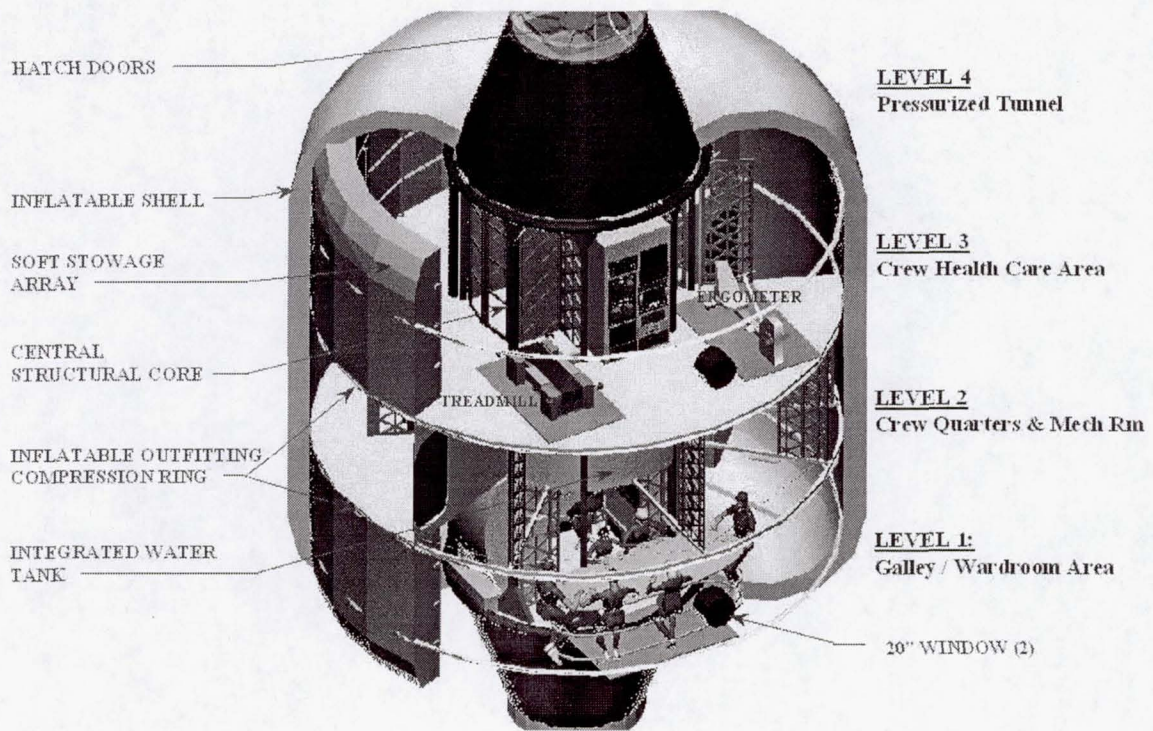

Figure 2. TransHab Overview

Levels one through three are for living space and the fourth is the connecting tunnel. The architecture of TransHab provides an integrated habitable environment that creates private and social spaces.

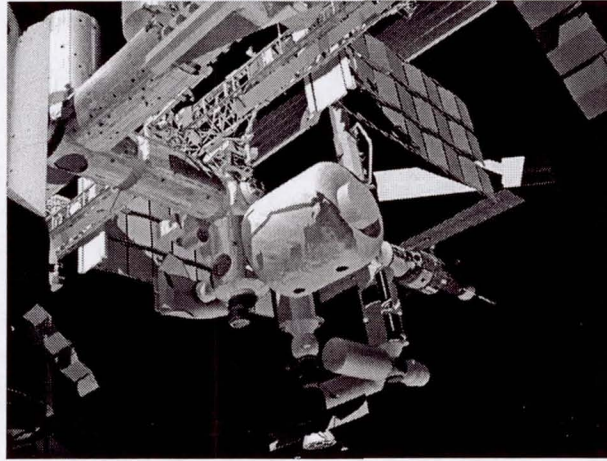

Figure 3. Proposed ISS TransHab on Space Station

TransHab is launched in the Space Shuttle for delivery to the ISS. After the Orbiter docks with the ISS, the TransHab is removed from the Orbiter payload bay and berthed with the ISS. Once connected to the ISS, the TransHab is deployed and inflated to its internal operating pressure of 760 torrs (14.7 psia). Deployment is achieved by releasing the launch restraint system (described in the deployment system section of this chapter). Following inflation of the module, systems are activated for conditioning the environment for crew entry and outfitting.

Level 1 incorporates the galley, wardroom and soft stowage area. This level has three ISS galley racks, a large wardroom table, an Earth-viewing window, and a soft stowage array that incorporates ISS standard collapsible transfer bags (Figure 4).

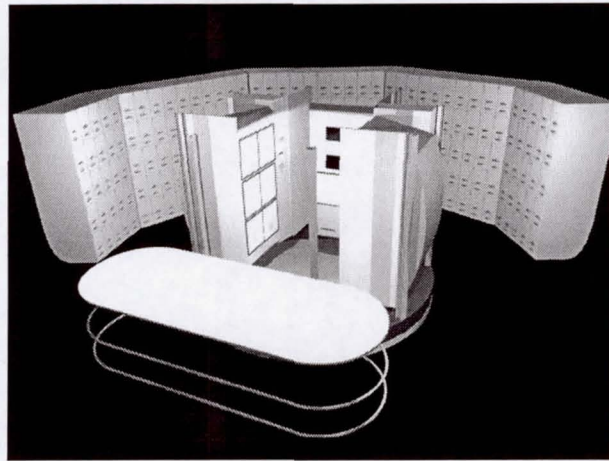

Figure 4. TransHab Level 1 Galley/Wardroom Area

A unique aspect about this area is that it includes a two-level open space above the wardroom area. This space was created in response to the psychological and visual creation of open space. This is very important for crew morale and productivity during long duration isolation and confinement in space.

Level 2 is composed of the mechanical room and six crew quarters (C.Q.). The Mechanical Room is external to the core structure and uses half the floor space of TransHab's diameter. The other half of this area is the open space above the wardroom area. The crew quarters are surrounded by a 5 – 7.6 cm (2" – 3") thick water jacket for radiation protection during solar flares. Each C.Q. will have personal stowage, a personal workstation, sleep restraint, and integrated air, light, data, and power (Figure 5).

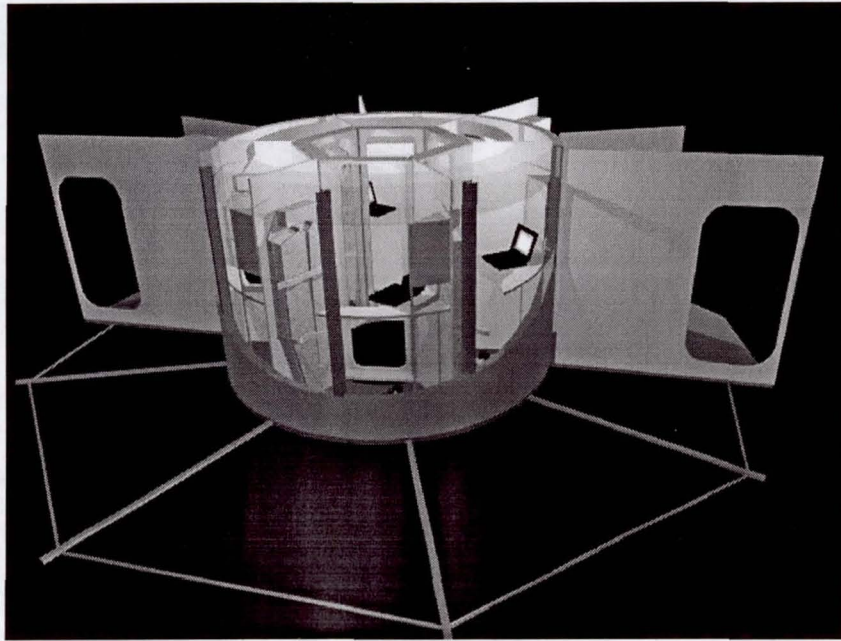

Figure 5. TransHab Crew Quarters, JSC S99-05359

Level Three is the crew health care and soft stowage area. The crew health care area incorporates two ISS Crew Health Care System (CHeCS) racks, a Full Body Cleansing Compartment (FBBC), changing area, exercise equipment (treadmill and ergometer), a partitionable area for private medical exams and conferencing, and an Earth-viewing window (Figure 6).

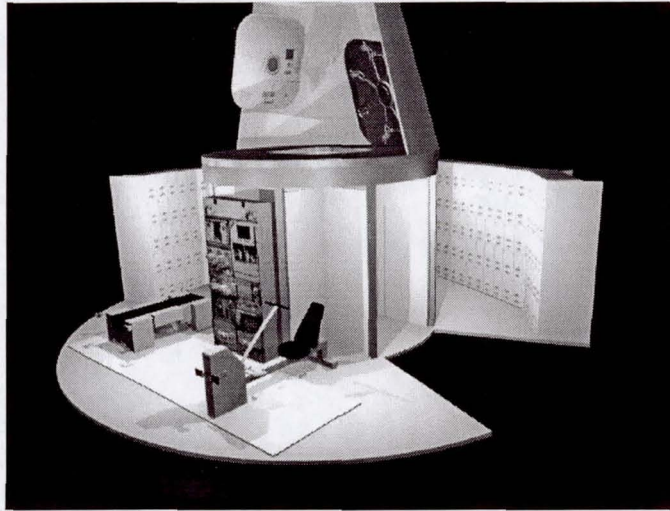

Figure 6. TransHab Level 3

Also included on this level is a soft stowage area identical to the stowage on level 1. Placement of the exercise equipment is synthesized with the window location to allow the crew to view the Earth while exercising. Some of the important habitability design objectives of TransHab were to maintain a local vertical configuration, separate the exercise area from the dining area, and provide larger crew quarters.

Level 4 is the pressurized tunnel area between the main TransHab cabin and the space station. It consists of two ISS standard hatches, avionics, and power equipment. Its function is to 1) provide a "transition" between ISS and TransHab, 2) house critical equipment required during inflation, and 3) provide structural connection to ISS. It is the only pressurized volume in TransHab during launch. The packaged central core will vent during launch to a vacuum state until TransHab is inflated.

3.0 Transhab Structure

3.1 Transhab Structure Overview

TransHab is a hybrid structure that incorporates an inflatable shell and a central stiff structural core (Figure 7).

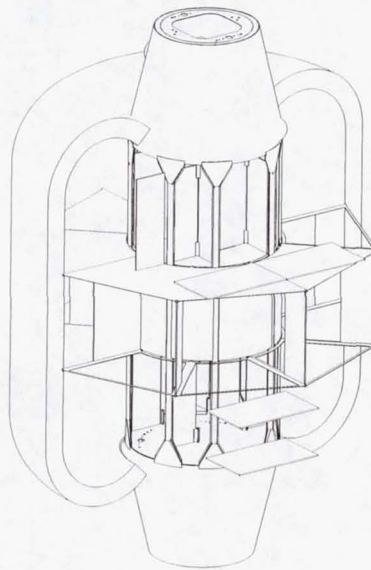

Figure 7. TransHab Structure

This unique hybrid structure combines the packaging and mass efficiencies of an inflatable structure and the advantages of a load carrying stiff structure.

The central core structure is comprised of eight longerons, repositionable launch shelves, bulkheads, radiation shield water tanks, utility chases (2), and integrated ductwork. The inflation system and tanks are incorporated into the unpressurized tunnel located at the end of the core. The launch shelves are attached to the

central core and are part of the primary structure for launch. About half of the shelves are repositioned once on-orbit and the others remain in place (Figure 8). The repositioned shelves will be used as part of the floor support system, equipment mounting in the mechanical room, and partitions.

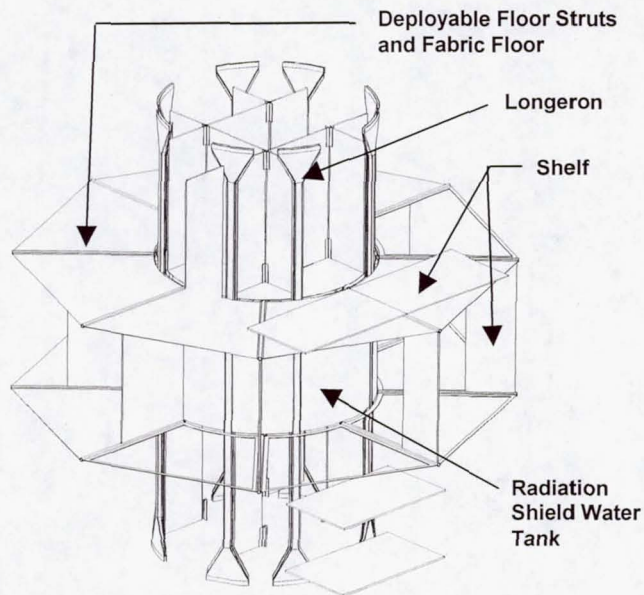

Figure 8. TransHab Deployed Core Structure

The next few sections will describe the structural design considerations when developing an inflatable habitat.

3.2 Environments

In order to properly design an inflatable habitation module, one must first understand the environment to which the module is exposed. The space environment is characterized by vacuum, orbital debris, micro gravity for orbital space stations and transfer missions, partial gravity for planetary exploration missions, radiation, temperature extremes, atomic oxygen, and planetary dust. A habitation module must be designed to protect humans from all of these environments.

3.3 Multi-Layer Shell

Inflatable habitation modules will be composed of several constituent layers. The type and number of layers will vary depending on the specific design requirements. The primary and most common components are discussed in this section and include (1) an inner liner, (2) a bladder, (3) a structural restraint layer (sometimes integral to the bladder), (4) micrometeoroid/orbital debris protection system and, (5) a thermal control layer and an atomic oxygen protective layer (see Figure 9). Other layers that may be required include, but are not limited to, a deployment system, an Electro-static discharge (ESD) system, and a radiation protective layer.

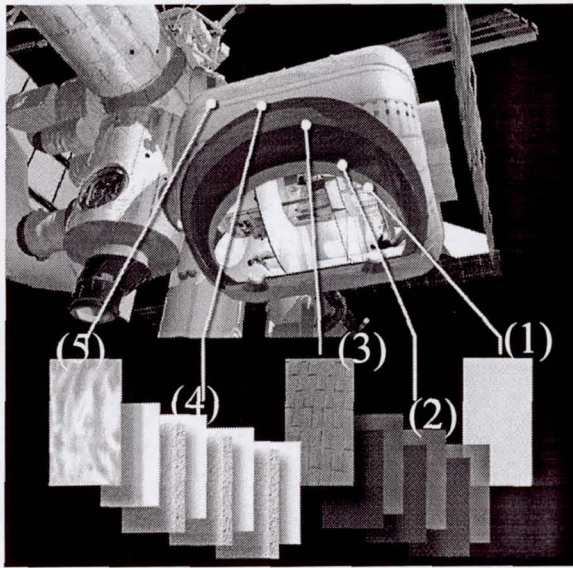

(a)

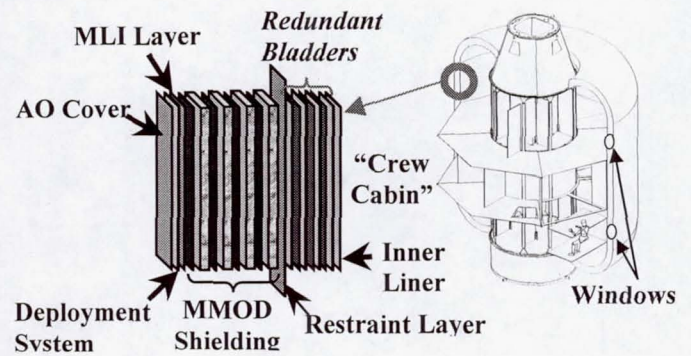

(b)

Figure 9: TransHab Shell Layers

3.3.1 The Inner Liner

The inner liner's function is to protect the bladder from internal hazards by providing a barrier that is durable, flame, and puncture resistant. The inner liner should also be easy to clean and have good sound suppression properties.

3.3.2 Bladder

The bladder is the primary gas barrier layer that maintains the air volume essential for life. For large volumes and/or long duration missions, a very low permeability rate is required to minimize re-supply of air. The bladder must also be flexible and durable during manufacturing, assembly, folding, and deployment under extreme temperatures.

It is desirable to oversize and properly index the bladder to the restraint layer and possibly inner liner. This will prevent the bladder from shifting out of position and taking load during deployment. The index system must be able to properly position the bladder without excessively loading the bladder locally at the index locations.

The bladder can be composed of single or multiple layers. A single layer is typically easier to design and manufacture but does not have the benefits of redundancy. When a multiple layer bladder system is designed, there should be a bleeder cloth between and around the individual layers to provide protection, as well as allowing a vacuum to be pulled between bladders. A multiple layer bladder system also requires ports between the bladder layers to allow venting on ascent and monitoring of pressure while on orbit. Adjacent layers can also be split into compartments. Although this adds complexity to the design and manufacturing, it will help in isolating leaks and could reduce rework due to manufacturing errors.

A material test program should be initiated to verify that the bladder meets the specific design requirements. Bladder testing typically involves: offgassing, puncture, flex (Bally, triple fold, etc), testing at temperature extremes (especially flex testing), seam testing, tensile testing, and permeability testing.

3.3.3 Restraint Layer: Analysis, Design, and Manufacturing

The Restraint Layer is the structural load-bearing layer of the inflatable shell. Its function is commonly compared to that of the leather layer of a football: it supports the bladder and carries the load induced by the internal pressure. The design of inflatable habitation modules is unique to most inflatables, because habitation modules are generally required to contain both a large volume and a high pressure. As a result, the restraint layer will need to be designed to carry an extremely high load.

3.3.3.1 Analysis

Thin-Walled Pressure Vessel Analysis

The analysis of the restraint layer is very similar to the analysis of thin-walled pressure vessels. The internal pressure imparts stress in two principal directions: hoop stress (σ_2) and longitudinal stress (σ_1). Since the geometry of the TransHab shell is composed of a cylindrical central region and two half-toroidal end-caps, we focus on two examples of common thin-walled pressure vessel shapes: a cylinder and a toroid. We also consider a sphere for comparison, since it is also a fundamental shape of pressure vessels.

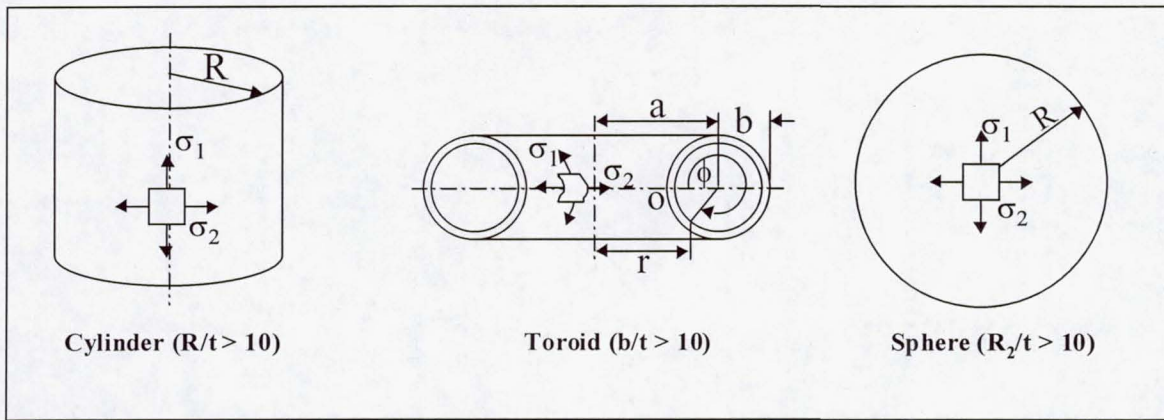

Figure 10. Orientation of hoop stress (σ_2) and longitudinal stress (σ_1) for thin-walled pressure vessels. Diagrams reproduced from *Roarks Formulas for Stress and Strain*, Young & Budynas.

(i) Cylinder The equation for the hoop stress in the cylinder is

$$\sigma_2 = \frac{qR}{t} \text{ (throughout)} \quad \text{(Equation 1)}$$

where q is the differential pressure between the internal volume and the exterior environment. For space applications, the external environment is near vacuum, so q simply represents the internal pressure of the module.

The equation for the longitudinal stress in the cylinder is

$$\sigma_1 = \frac{qR}{2t} \text{ (throughout)} \quad \text{(Equation 2)}$$

(ii) Toroid The equation for the hoop stress in the toroid is

$$\sigma_2 = \frac{qb}{2t} \text{ (throughout)} \quad \text{(Equation 3)}$$

The equation for the longitudinal stress in the toroid is

$$\sigma_1 = \frac{qb}{2t} \frac{r(\phi) + a}{r(\phi)} \quad (r \text{ is a function of } \phi, \text{ measured from point } O) \quad \text{(Equation 4)}$$

The maximum longitudinal stress in the toroid occurs when $r(\phi) = (a-b)$.

$$\text{Max} \sigma_1 = \frac{qb}{2t} \frac{(a-b) + a}{(a-b)}$$

$$\text{Max} \sigma_1 = \frac{qb}{2t} \frac{2a-b}{a-b} \quad (\text{located at point } O) \quad \text{(Equation 5)}$$

(iii) Sphere The hoop stress and longitudinal stress in a sphere are identical.

$$\sigma_2 = \sigma_1 = \frac{qR}{2t}$$

(Equation 6)

General Design Considerations

From Equations (1) through (6), it can be seen that the hoop stresses in the cylinder will be the highest out of the three forms. Therefore, for conventionally-shaped cylindrical modules, the diameter of the pressure vessel will be governed by the hoop stress and the associated material strength.

The hoop stress in the cylindrical region is directly proportional to the diameter (or radius) of the pressure vessel. Therefore, it can be seen that large inflatables, such as the 8.23-meter diameter TransHab, are required to support much larger loads than conventional 4.57-meter diameter modules.

It is also important to point out that the toroid shape is unique among the three shapes because there is no structural limit to how large the major diameter of the toroid can be. This can be seen by investigating Equation (5). Notice that

$$\lim_{a \rightarrow \infty} \left(\frac{2a - b}{a - b} \right) = 2 \quad (\text{with } b \text{ remaining relatively small}) \quad (\text{Equation 7})$$

Therefore, as “a” becomes large, equation (5) becomes:

$$\text{Max} \sigma_1 = \frac{qb}{t} \quad (\text{Equation 8})$$

Notice that this is the same equation as the hoop stress in a cylinder. So, for a toroid, the stress is dependant on b , but independent of a . This means that a toroid-shaped (unlike a cylindrical or spherical-shaped) pressure vessel is not limited structurally to what maximum diameter it can be. For example, the maximum stress in a module with dimensions of $a = 30$ meters and $b = 6$ meters, is the same as the maximum stress in a toroidal-shaped module with dimensions of $a = 3000$ meters and $b = 6$ meters. Therefore a toroidal shape may be desirable from a structural-design perspective when an extremely large volume is required.

3.3.3.2 DESIGN

Restraint Layer Strength Requirement

Once the analysis has been performed, as described in section 3.3.1, the strength requirement of the restraint layer can be determined. Metallic pressure vessels for use on the International Space Station (ISS) are designed to a factor of safety (FOS) =2.0 on ultimate strength, as specified in SSP 30559, *Structural Design and Verification Requirements*.

However, due to the larger manufacturing tolerances, load sharing, and loading uncertainties involved with fabrics, the Federal Aviation Administration (*Airship Design Criteria*, FAA-P-8100-2) requires that all inflatable airships (blimps) be

designed to FOS=4.0 for ultimate. Therefore, the TransHab team imposed this same requirement on the restraint layer design.

Seams

Typically structural seams in high strength webbings have seam efficiencies that vary from 80% to 90%, meaning that each seam is 10% to 20% weaker than the general fabric strength. Therefore, it is necessary to add 10% to 20% to the strength requirement of the fabric, to take into account this loss of strength in the seams. The seam efficiency values should be tested and verified for each specific application because there can be significant variance depending on material strength, width, weave style, and seam type.

Restraint Layer Material Selection

Due to the FOS=4.0 requirement, the strength of the restraint layer generally needs to be extremely high. Table 1 summarizes material properties of the common high-strength fabrics.

Fiber Type	Tensile Strength (N/m ² x10 ⁶)	Breaking Tenacity (gm/den.)	Tensile Modulus (gm/den.)	Elongation at break (%)	Density (gm/cm ³)	Resistance to Flex Cracking	Low Temp. Brittleness (°C)	Flammability (LOI)	Abrasion Resistance
Kevlar	3.38	23	555	3.6	1.44	Fair	<-196	27-29	Fair
PBO	5.65	41	1300	3.5	1.5	Fair	-	>56	Fair
Spectra 1000	2.99	35	2000	2.7	0.97	Excellent	<-25	18-19	Excellent
Vectran HS (LCP)	2.84	23	680-840	2.2-2.5	1.41	Good	<-160	28	Good

Data/Testing Provided by Rajib dasGupta, Lockheed Martin

Table 1: Comparative Evaluation of Candidate Fabrics for the TransHab Restraint

Although the tensile strength of PBO (*p*-phenylene benzobisoxazole) is almost twice as high as Kevlar (*p*-phenylene terephthalamide) or Vectran (liquid crystal polymer fiber spun from wholly aromatic polyester), the TransHab program did not consider PBO a viable candidate due to its high cost, limited availability, difficulty in preparation, and limited material database when the material selection was made in 1998. Spectra (a polyolefin fiber spun from a solution of Ultra High Molecular Weight Polyethylene, UHMWPE) has adequate tensile strength. However, its brittleness property at low temperature (<-25 °C) eliminated it as a viable candidate.

The TransHab program selected Kevlar over Vectran because of its significant flight history, well known properties, availability, and low cost. Concerns related to flex cracking or abrasion resistance are not applicable due to the large folding radius and low flexing cycles that the restraint layer will see for this application.

Restraint Layer Fabric-Form Selection

There are several different forms that can be used to construct a restraint layer. Because the TransHab program built 3 full-scale Shell Development Units (SDUs) in 1998, we will take a look at the design path of the fabric style selection that was taken while designing and building the first three full-scale test articles.

TransHab considered the following fabric-style options for the design of the restraint layer:

- (i) Multiple layers of fabric
- (ii) Multi-layer fabric
- (iii) Wide webbing
- (iv) Narrow webbing

(i) Multiple Layers of Fabric

Multiple layers of fabric involve sewing several layers of Kevlar fabric together to achieve the strength necessary to withstand the pressure loads. However, this design has two drawbacks.

First, when sewing several layers of fabric together attempting to make it act as a single unit, it is very difficult, if not impossible, to achieve proper load-sharing through-out the layers.

Second, when designing curved geometrical shapes other than cylinders (such as toroids) the fabric is cut into gore patterns and then sewn together to achieve this shape (see Figure 11). It is important to realize that when making the gore patterns, the load-carrying fibers (shown dashed) are being cut, thus significantly reducing the strength of the gore sections. However, gore patterns are a good design solution when the strength requirement is not extremely high.

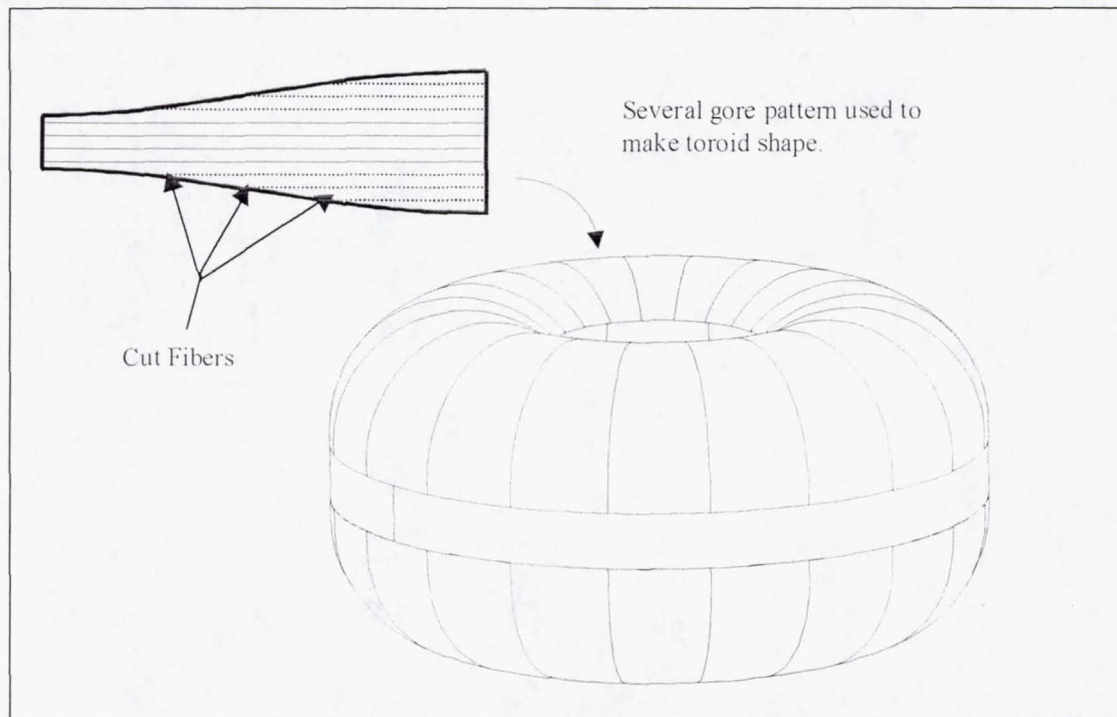

Figure 11. Using gore patterns to make toroidal shapes. Note that the load carrying fibers are being cut.

(ii) Multi-Layer Fabric

It is possible to have certain webbing vendors produce a "custom weave" of fabric that meets the strength requirement for the restraint layer.

However, in order for a custom woven fabric to be strong enough to satisfy the TransHab's strength requirement (1629 kg/cm in the hoop direction, and 701 kg/cm in the longitudinal direction) it is required to be over 0.635 cm thick. This means that at certain seam locations the joint will be over 4 cm thick! This thickness would make sewing very difficult as well as introduce additional load cases (such as moments generated in the thick joints). Load transfer through such thick seams would be very difficult to achieve.

The multi-layer fabric design also needs to be cut into gore patterns to achieve the toroidal end-caps. This introduces the same load sharing and strength concerns mentioned above for gore patterns.

(iii) Wide Webbing

Due to the drawbacks and concerns with the fabric options, it was decided to make the TransHab Shell Development Unit 1 (SDU-1) out of wide webbing as shown in Figure 12. A cross-sectional view of SDU-1 is shown in Figure 13. Since the loads in the shell are independent of the cylindrical height on the shell, it was decided to make the SDU-1 article short to simplify manufacturing and reduce the cost.

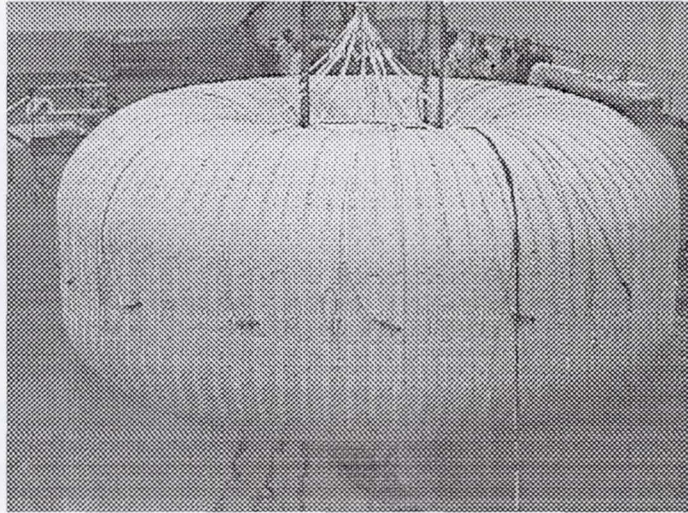

Figure 12. TransHab's Shell Development Unit 1 (SDU-1) was comprised of wide (30.48cm, 15.24 cm, and 2.54 cm) Kevlar webbing.

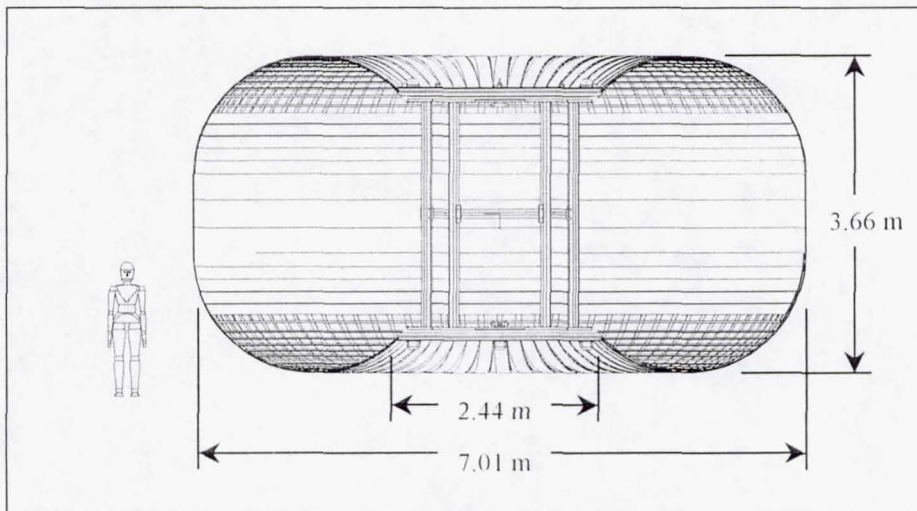

Figure 13. Cross-section view of TransHab's Shell Development Unit 1 (SDU-1). Notice the central structural core, comprised of two bulkheads and eight longerons.

The longitudinal straps ran along the outside of the hoop straps. The longitudinal straps and hoop straps were indexed (sewn) to each other at every strap

intersection using nylon thread. Prior to assembly, each strap was rolled out on a table, pre-tensioned, and marked in the appropriate locations to identify where to place the index stitches and the structural seams.

On May 28, 1998, SDU-1 was successfully pressurized to greater than 2.5 times operational pressure, thus demonstrating the capability of a design using wide webbing.

However there were three drawbacks to the use of wide webbing. First, there was uneven loading near gaps in the restraint layer that were created as a result of the geometry.

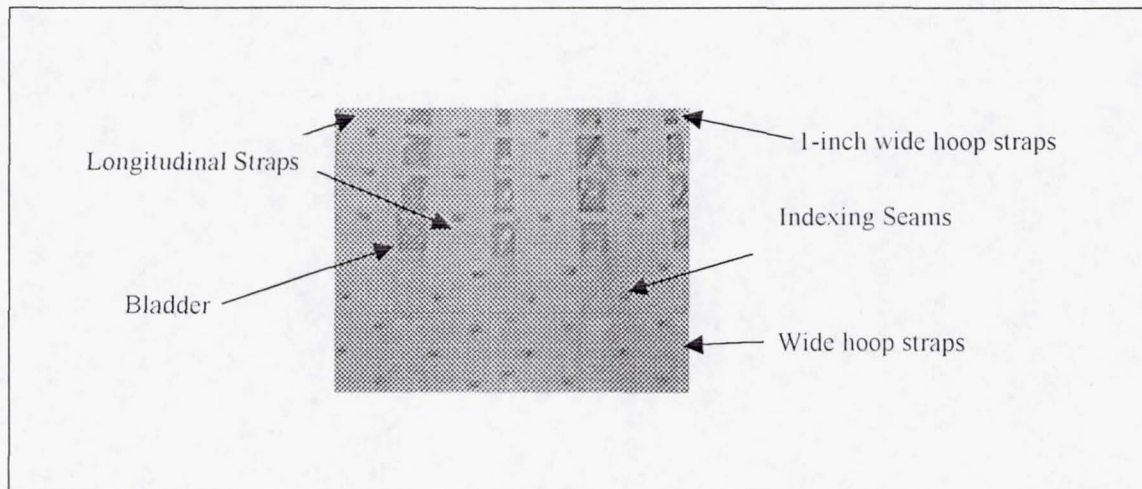

Figure 14 Gaps in the SDU-1 restraint that resulted in uneven loading.

The second drawback is that it is not possible to get complete load sharing across the webbing, simply due to the fact that the flat webbing must assume a curved shape across the strap width in order to form the inflated shape.

The third drawback, to the wide-webbing design, was the difficult manufacturing process involved with such a design. Initially it was thought that wide webbing would be easier for manufacturing since there would be fewer straps and seams. However, the opposite was shown to be true during manufacturing. It was extremely difficult to maneuver the heavy, dead weight of the webbing around to the sewing machines in order to produce the seams.

(iv) Narrow Webbing

Due to the drawbacks of wide webbing mentioned above, the TransHab Shell Development Unit 2 (SDU-2) was made completely out of 2.54-cm (1-inch) wide webbing. Due to the large quantity of narrow straps required for this design, the SDU-2 restraint layer was woven together by hand and indexed with a hand-stitch approximately every meter. Prior to weaving, each strap was rolled out on a table, pre-tensioned, and marked in the appropriate locations to identify where to place the index stitches and the structural seams.

However, when the SDU-2 was first inflated it was soon evident that there were not enough indexing stitches installed in the Restraint Layer, because the weave was loose and not conforming to the intended geometry. Therefore, the entire SDU-2 was disassembled and re-woven. This time the nylon indexing stitches were sewn in a 1meter by 0.50-meter repeating frame pattern. Once again prior to weaving, each strap was rolled out on a table, pre-tensioned, and marked in

the appropriate locations to identify where to place the index stitches and the structural seams.

The modified SDU-2 was then inflated a second time. The additional indexing stitches "locked" the weave in place and the restraint layer inflated to the correct geometrical shape. On September 12, 1998 the TransHab SDU-2 (re-woven version with additional indexing stitches) was successfully proof tested to a factor of safety = 4.0 (4 atmospheres differential pressure) at the Johnson Space Center, making it possibly the highest loaded inflatable in history (refer to Figure 19 in the *Testing* section).

Fifteen days after the SDU-2 proof test, the Johnson Space Center began fabrication of the TransHab SDU-3 restraint layer. The SDU-3 restraint layer was also woven by hand and contained over 10 miles of Kevlar webbing that was indexed together with over 26,000 nylon hand stitches. Four weeks later, working multiple shifts, it was completed.

SDU-3 was a full-scale shell development unit that had a micro-meteorite/orbital (MMOD) debris shield installed over the restraint layer and was used to demonstrate folding and deployment in a vacuum. Figure 15 shows the inflated SDU-3 prior to MMOD installation.

These first three TransHab restraint layers were instrumental in proving that highly loaded, large diameter inflatable structures can be manufactured to meet strict design requirements, as well as be manufactured in much less time than conventional aluminum structures.

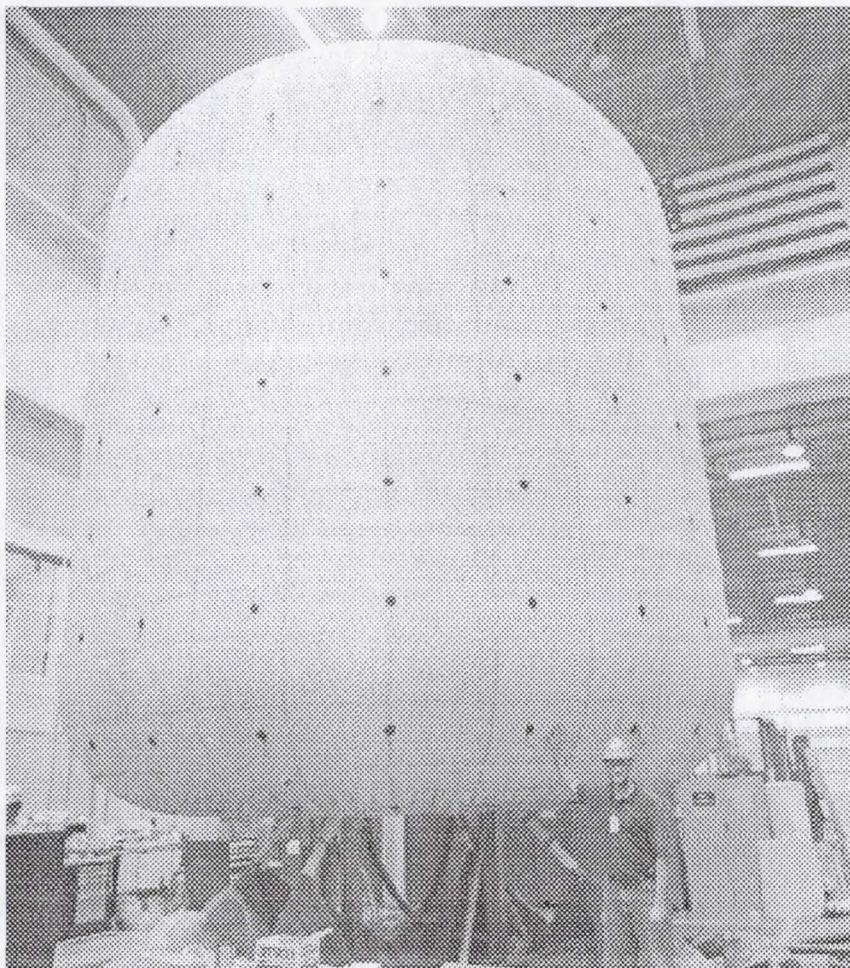

Figure 15. The TransHab Shell Development Unit 3 (SDU-3) woven restraint layer inflated.

3.3.4 Micrometeoroid/Orbital Debris (M/Od) Protection System

Lightweight, fully flexible shields are required to provide protection from meteoroid and orbital debris (M/OD) impact for inflatable spacecraft under consideration for missions in Earth orbit and beyond. Previous shielding designs for inflatables were added post-inflation. Depending on the type of shielding, this can prove to be heavy, expensive, and labor intensive. It is desirable to have a pre-integrated, deployable, fabric shield that exceeds the performance of conventional shields. Although there are various types of M/OD shields, this discussion is limited to pre-integrated compressible and deployable, multi-layer, all fabric shields similar to NASA's TransHab shield, which is the state of the art in hypervelocity impact (HVI) protection for inflatables.

The TransHab shield consists of several layers of Nextel™ ceramic fabric layers that are separated by open cell polyurethane foam. The purpose of the foam is to provide a standoff distance between the Nextel layers. The foam is vacuum compressed prior to launch, to minimize volume and allow the shell to be easily folded. On orbit, in the vacuum of space, the foam regains its original standoff thickness due to the resilience of the foam and lack of differential pressure.

Behind the alternating layers of Nextel and foam is a high strength Kevlar™ fabric rear wall. As the hypervelocity particle impacts each of the multiple Nextel layers, it is continually shattered into smaller, slower particles over a larger area.

With a properly sized shield, by the time the particles reach the Kevlar rear wall, they are small and slow enough to be stopped.

3.3.5 Thermal Control Layer

Due to the extreme temperatures in space, a thermal control system is required to maintain a habitable internal environment. With an efficient spacecraft design, the majority of the thermal gradient occurs across the thermal control layer(s). Typical layers consist of thermal blankets and/or multi-layer insulation (MLI). MLI is primarily composed of multiple layers of highly reflective layers sandwiched between durable reflective layers. The MLI layers are usually perforated to allow venting. Dedicated vents can also be added to these layers.

Thermal analysis of proposed shields is performed using finite element or finite difference thermal models. These models are then correlated by running sub-scale and full-scale tests at vacuum.

Pre-integrated thermal layers can be fabricated in gore sections and then assembled onto the shell. The thermal blankets should be oversized with respect to the shell layers to prevent them from carrying load and minimizing thermal conduction between MLI layers.

3.3.6 ATOMIC OXYGEN PROTECTIVE LAYER

All spacecraft in low-earth orbit that will be exposed to atomic oxygen (AO) and may require additional protection. Typically the outermost layer will be composed of an AO protector such as Betaglass fabric. Betaglass fabric is used throughout the space program and has been proven to protect against atomic oxygen damage. Vent holes and vent covers may be necessary to prevent the AO cover from overpressurizing on ascent. The AO cover should be oversized with respect to the adjacent layer(s) to prevent it from carrying load. MLI and AO layers may need to be grounded to an aluminum structure to prevent the build-up of electro-static charge.

3.3.7 DEPLOYMENT SYSTEM

The deployment system is required to restrain the folded shell layers prior to deployment. The deployment system must be able to withstand the pressure build-up due to venting of the shell layers during ascent. Various design options are available. One of the options is to design a deployment system external to the shell layers. This is advantageous in that there are not any long term issues of contamination (outgassing) provided the external deployment system is removed and properly disposed. However, removal and disposal will create additional design requirements. Alternatively, a deployment system integral to

the shell layers can also be designed. This was the option chosen during the vacuum deployment test of NASA's TransHab.

3.3.7.1 Transhab's Integral Deployment System

The deployment system consists of a series of deployment straps that span every third gore (deployment gores). When the test article is folded, every third gore is pushed in towards the central core (Figure 16). The adjacent gores are folded over so that the ends of the deployment straps on one deployment gore line up with the ends of the deployment straps on the next deployment gore. Deployment cords are then tied to each end of the deployment straps and laced together in a daisy chain manner (Figure 17). The deployment straps form multiple segmented rings that fully contain the folded assembly. Each set of daisy chains can be released from a single "cut" location using redundant pyrotechnic guillotine cutters. Since there are seven deployment gores, there are seven independent "cut" locations. This deployment system was proven in the TransHab Shell Development Unit III, full-scale deployment test at vacuum.

An alternate embodiment would include adding an additional daisy chain that would free all independent deployment release location in series. This would allow the entire deployment system to be released from a single cut location.

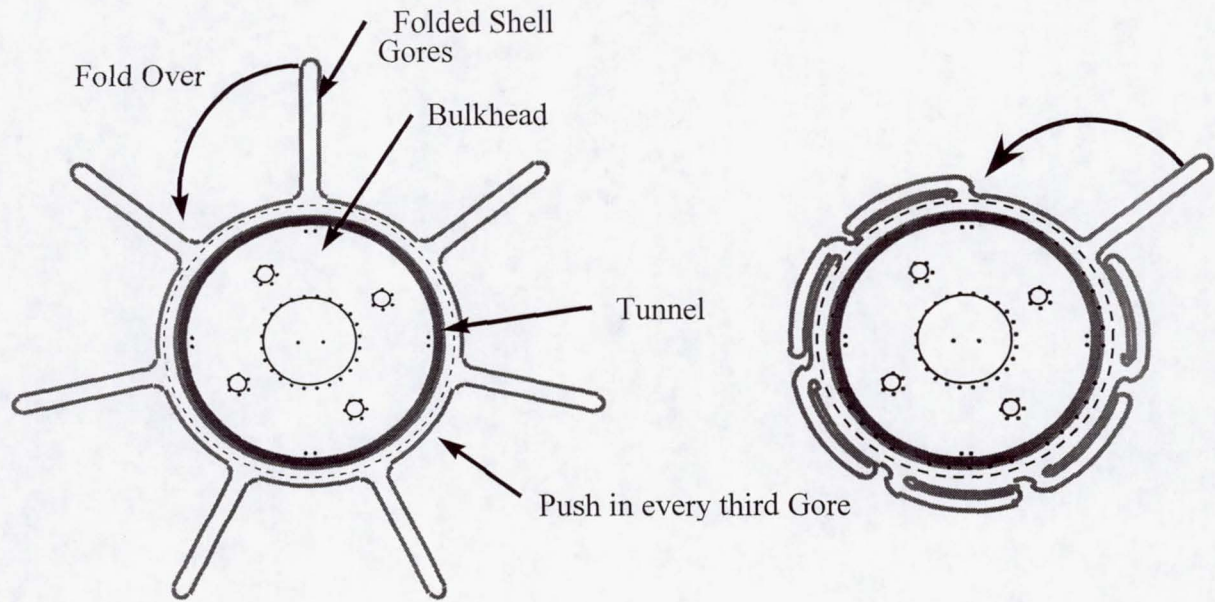

Figure 16: Folding Scenario

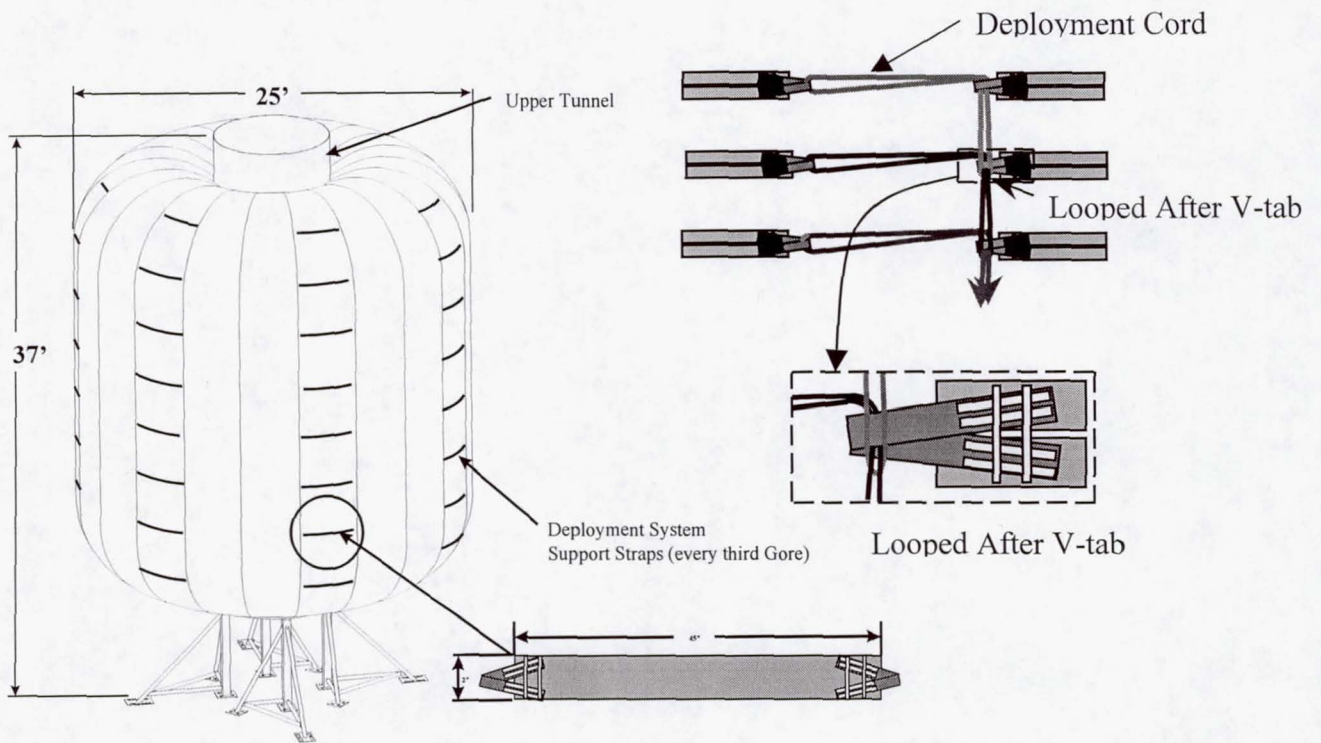

Figure 17: Deployment System

3.3.8 SHELL-TO-CORE INTERFACE

The interface between the inflatable shell and the central core or hatch interface is the most critical area of the module. This is where the bladder must maintain a leak tight seal and the restraint must react the shell load into the core. For designs where the bladder and restraint are independent, the interface attachments should be independent to prevent the bladder from getting loaded by the restraint layer.

3.3.8.1 RESTRAINT LAYER INTERFACE

Once again there are many design options here. One option is to design a conical compression ring that the restraint layer would wrap around. As the load in the restraint increases, the pressure load on the ring and attach interface increases. The advantage to this type of attachment is that while the load increases, the conical ring reacts the load in hoop tension. The disadvantage is that you may not get good load sharing across and around the restraint layer because it is being compressed against the interface, which in-turn could damage the restraint layer. This type of design was used during the successful test of the, 7.0 meters (23-ft.) diameter, TransHab Shell Development Unit I that was inflated hydrostatically to a differential pressure greater than 2.5 atmospheres.

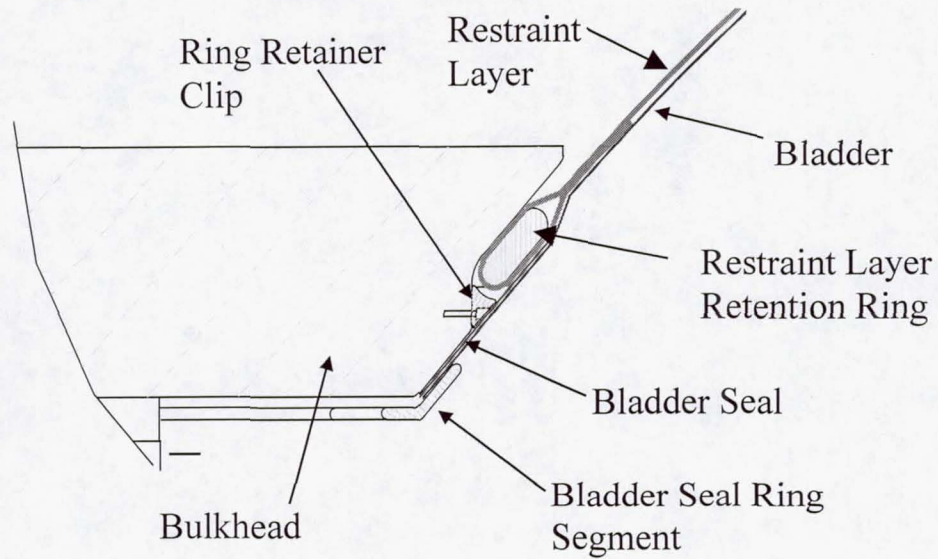

C1

Figure 18: TransHab SDU-I Seal Interface

For restraint layers fabricated from narrow webbings, 2-5 centimeters (1-2 inches) wide, the restraint layer interface can be made by using individual clevis/roller assemblies to attach the restraint straps to the attach interface. Large radius rollers can be used to prevent creasing of the straps. The rollers also enable load sharing between two adjacent straps by allowing the straps to “self adjust”. This type of design was used during the successful test of the 7.0 meter (23-ft.) diameter TransHab Shell Development Unit II that was inflated hydrostatically to a differential pressure of 4 atmospheres.

3.3.8.2 BLADDER INTERFACE

There are numerous design solutions to sealing the bladder interface. Two design options are listed below.

The bladder can be attached directly to the interface using a compressed tapered ring, as shown in Figure 18. Another option for directly attaching the bladder to the interface is using a conventional bore or face seal with o-rings. The bore seal typically will have tighter tolerance requirements than a face seal. With any of these seal designs, it must be verified that there are not any long-term cold-flow effects of the bladder, due to the compressive loads of the o-rings, at the expected temperature ranges.

The bladder interface can also be made by bonding the bladder to a metallic interface ring using a flexible flight certified adhesive sealant. The metallic ring can then be sealed to the core using conventional o-ring seals.

In using any of the previously mentioned bladder designs, over sizing the bladder with respect to the restraint layer and properly indexing the bladder to the restraint layer are essential in maintaining a zero stress environment for the bladder seal interface.

4. Testing

Although numerous material and development test are required in developing an inflatable habitation module, only a few of the milestone tests will be discussed in this next section.

4.1 Hypervelocity Impact Testing (M/OD Protection)

A variety of hypervelocity impact tests, using different size particles at speeds ranging between 2.5 through 11 km/s, have verified the TransHab multi-shock shield. Initial ballistic limit equations have been developed from these test for use in shield optimization. As an example, the sub-scale and full-scale testing demonstrated that the TransHab shield can stop a 1.7-cm diameter aluminum particle traveling at 7 km/s fired at both 0 and 45 degree impact angles. The results of these tests have verified that the current TransHab M/OD shield exceeds the ISS M/OD shield requirement for a habitation module.

4.2 Hydrostatic Pressure Testing

As mentioned before, to verify the structural integrity of the Kevlar restraint layer, a hydrostatic test was performed on a 7.0 meter (23 foot) diameter development unit. On September 12, 1998, a 7.0 meter (23 foot) diameter inflatable, TransHab Shell Development Unit II (SDU II), was lowered into the 23.5 million liter (6.2

million-gallon) water tank at JSC's Neutral Buoyancy Laboratory (see Figure 19). To minimize safety hazards, instead of pressurizing the test article pneumatically, the test was conducted hydrostatically and under water. A 10% degradation was taken into account due to the frictional effects of water on Kevlar webbing. The test article was successfully pressurized to four times the ambient pressure at sea level. This represented a significant milestone in validating large-scale inflatables for potential space applications.

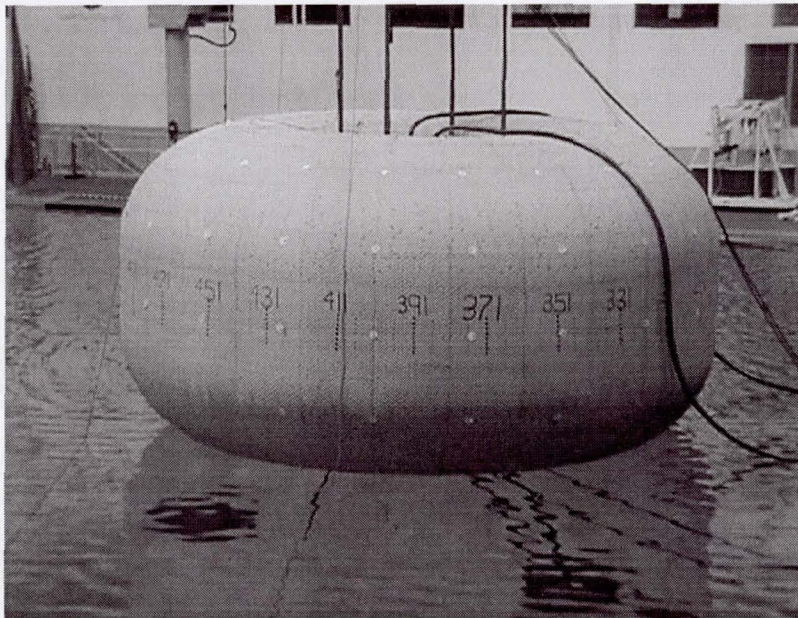

Figure 19: TransHab SDU Hydrostatic Test (4.0 X ambient)

4.3 FOLDING AND VACUUM DEPLOYMENT

To demonstrate the ability to assemble, package, and deploy the multi-layer shell, a full-scale test article, called SDU III, was manufactured and assembled. After verifying the structural integrity of the restraint layer, it was safe to

pressurize the SDU III pneumatically. The full-scale development unit was folded while in a vertical configuration. In order to accomplish this a series of four cables were attached to each of the 21 gore interfaces. The 84 cables were attached to an overhead support fixture that supported the 4,500 kilogram (10,000 pound) shell weight and allowed each gore to be folded. In order to fold the 21 gores, every third gore was pushed in towards the central core. Each of the seven adjacent gores was folded over (recall Figure 16). The SDU III test article was slowly deflated, transferring the shell weight to the overhead support structure, and Kevlar webbing was used to draw in the 14 gore-to-gore seam interfaces. Temporary segmented hoops were created, using some of the deployment straps, and then incrementally tightened to help fold the SDU III into the proper configuration. Finally, the test article deployment system was laced up (daisy chain, recall Figure 17) and tied off with pyrotechnic test cords. The SDU III was successfully folded with minimal ground support equipment (Figure 20). The final packaged diameter was small enough to fit in the shuttle cargo bay.

After the SDU III was folded and all pyrotechnic cutters were armed, JSC's seven-story thermal vacuum Chamber A was pumped down to approximately 27 torr (0.5 psi.). The deployment system maintained the packaged configuration throughout Chamber A pump down. Next, all pyrotechnic cutters were fired thereby releasing the packaged shell. The SDU III was then re-inflated to ambient differential pressure (Figure 21). The inflation system used a prototype

heat exchanger to heat the gas during inflation. This test was successfully completed in late December 1998.



Figure 20: TransHab SDU III Folded

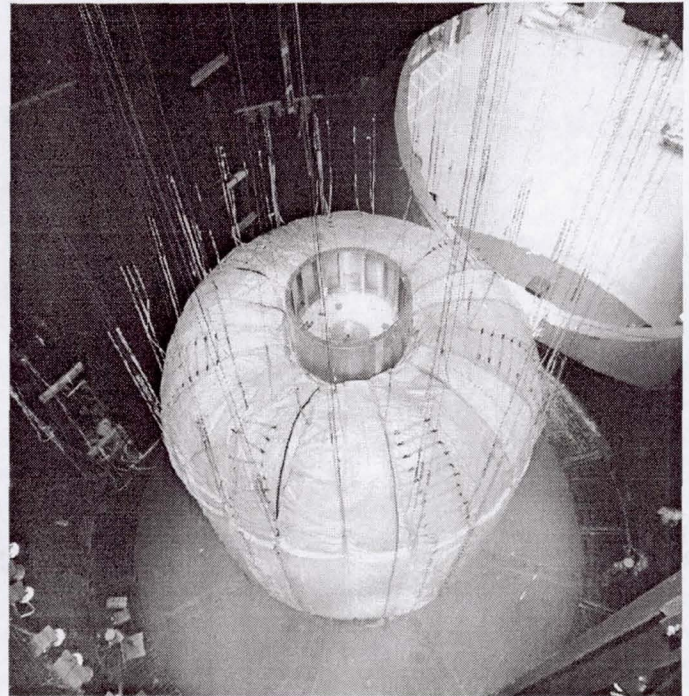

Figure 21: TransHab SDU III Deployed

5.0 Conclusions

The technologies required to design, fabricate, and utilize an inflatable module for space applications has been demonstrated and proven by the TransHab team during the development phase of the program. Through testing and hands-on development several issues about inflatable space structures have been addressed, such as: ease of manufacturing, structural integrity, micrometeorite protection, folding, and vacuum deployment. The TransHab inflatable technology

development program has proven that not only are inflatable structures a viable option, but they also offer significant advantages over conventional metallic structures.

6. REFERENCES

For more information about the ISS TransHab please contact NASA Johnson Space Center's Public Affairs Office.

- 1 Brown, G. & Harris, P. (Oct., 1998) *SBIR Advanced Habitats Phase I Final Technical Report*. Vertigo, Inc. Report Document #2000-11-0001, Lake Elsinore, CA.
- 2 Kennedy, K.J. (1999) *ISS TransHab Architecture Description*. Proceedings of the 29th International Conference on Environmental Science (ICES); paper #1999-01-2143. Society of Automotive Engineers, Warrendale PA
3. Kennedy, K. and Harris, P. (2000). "Wound Construction of Inflatable Space Structures." SPACE 2000: Engineering, Construction, and Operations in Space Conference. Published by ASCE
4. Kennedy, K. and Adams, C. (2000). "ISS TransHab: An Inflatable Habitat." SPACE 2000: Engineering, Construction, and Operations in Space Conference. Published by ASCE

5. Kennedy, K. and Capps, S. (2000). "Designing Space Habitation." SPACE 2000: Engineering, Construction, and Operations in Space Conference.
Published by ASC
6. (1995) Man-System Integration Standard, Vol. 1, NASA STD-3000, Rev. B.
NASA-Johnson Space Center, Houston, TX.
7. E. L. Christiansen, J.H. Kerr, H.M. de la Fuente, and W.C. Schneider (1999),
Flexible and Deployable Meteoroid/Debris Shielding for Spacecraft, International
Journal of Impact Engineering, Vol. 23.
8. (1996), Advanced Structural and Inflatable Hybrid Spacecraft Module, Patent
Application NASA Case # MSC-22900-1.
9. (1999), Advanced, Large Volume, Highly Loaded, Hybrid Inflatable Pressure
Vessel, Patent Application NASA Case # MSC-23092.
10. C. Johnson (July 1998), TransHab Shell Development Unit (SDU)
Hydrostatic Test Report, TH-TR-0001.
11. C. Johnson and G.D. Valle (June 1999), TransHab Shell Development Unit II
(SDU II) Hydrostatic Test Report, TH-TR-002.

12. G.D. Valle (May 1999), TransHab Full Scale Development Unit (SDU III)

Fabrication, Folding and Vacuum Deployment Post-Test Report.

13. de la Fuente, Raboin, Spexarth and Valle (2000), TransHab: NASA's Large-Scale Inflatable Spacecraft, 2000 AIAA Space Inflatables Forum; Structures, Structural Dynamics, and Materials Conference, 3-6 April 2000, Atlanta GA, AIAA 2000-1822

14. NASA International Space Station TransHab Web Page,

<http://spaceflight.nasa.gov/station/assembly/elements/transhab/>