

Evaluation of Lightning Induced Effects in a Graphite Composite Fairing Structure (Part 1)

Dawn Dawn H. Trout ^{#1,*1}, James E. Stanley ^{#3}, Parveen F. Wahid ^{#2},

[#] *School of Electrical Engineering and Computer Sciences*

University of Central Florida, Orlando, FL 32816-2450, USA

¹dawn.h.trout@knights.ucf.edu, ²wahid@eeecs.ucf.edu

School of Electrical and Computer Engineering

Florida Institute of Technology

Melbourne, FL 32901, USA

³jes@fit.edu

^{*} *Kennedy Space Center, VA-H3*

Kennedy Space Center, FL 32899, USA

¹ dawn.h.trout@nasa.gov

Abstract— Defining the electromagnetic environment inside a graphite composite fairing due to lightning is of interest to spacecraft developers. This paper is the first in a two part series and studies the shielding effectiveness of a graphite composite model fairing using derived equivalent properties. A frequency domain Method of Moments (MoM) model is developed and comparisons are made with shielding test results obtained using a vehicle-like composite fairing. The comparison results show that the analytical models can adequately predict the test results. Both measured and model data indicate that graphite composite fairings provide significant attenuation to magnetic fields as frequency increases. Diffusion effects are also discussed.

Index Terms—composite, magnetic, MoM, lightning, shielding

I. BACKGROUND

Direct strike lightning effects have been thoroughly evaluated for composite aircraft structures [1]. In the space industry, launch commit criteria and ground protection systems such as catenary wires shift the focus for launch vehicle protection to indirect effects. A thorough test program for the propagation of lightning induced magnetic fields through the fairing structure has not been conducted by launch vehicle industry. Previous work concentrated on lightning coupling analysis of the large umbilical cable connecting ground support equipment to vehicle and spacecraft power and data circuits as shown in Fig. 1. Accordingly, any shielding from indirect lightning effects afforded by the structure is not claimed by vehicle providers, and spacecraft developers are left with the assumption of no protection from indirect effects. The focus of this study is on the internal loop coupling from external lightning induced fields through the fairing structure (Fig. 1).

A minimal shield transfer impedance is required to reduce the common mode coupling to a differential circuit [1,2]. When design criteria prohibits shielding, voltages induced into sensitive circuitry are primarily driven by loop area, magnetic field amplitude and transient rise time. Spacecraft instrumentation designed for thermal isolation constraints have limited application of rigorous coupling reduction techniques such as twisting and shielding. Hence a cancellation of the magnetic field via loop area reduction is not feasible.

The time varying magnetic and electric fields lead to induced voltages and currents in vehicle and spacecraft circuitry. The governing equation to determine the magnetic field from a nearby lightning strike is depicted in (1).

$$\oint H \cdot dl = I_c + I_d = I_c + \int_s \frac{\partial}{\partial t} (\epsilon_0 E) da$$

Where:

H = magnetic field

l = length of loop

I = lightning current

I_d = displacement current

E = Electric Field

A = loop area

ϵ_0 = permittivity of free space = $8.85 \times 10^{-12} \text{ F/m}$

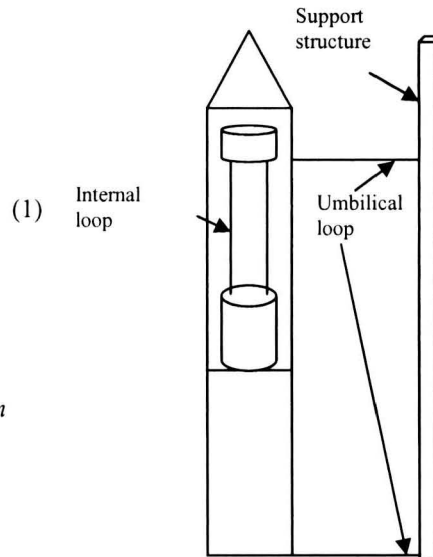

Fig. 1. Launch vehicle and umbilical tower

MIL-STD-464 provides the change in electric field contributed by a near lightning strike 10 m away as 6.8×10^{11} Volts/meter/second (V/m/s) [3]. Assuming a reasonable worst case circuit area, A , of $4 \text{ m} \times 0.05 \text{ m} = 0.2 \text{ m}^2$, the contributing portion of the magnetic field due to the displacement current (I_d) is 1.2 A/m [1]. Since this portion of the magnetic field is insignificant compared to the contribution of the lightning channel current, magnetostatics are often used to calculate the lightning based magnetic fields. In this case the magnetic field is $I_c/(2\pi r)$, where r is the distance from the strike and $2\pi r$ represents the circumference of the circle with radius, r . Although Uman provides formal solutions, it is common to rely on magnetostatics and the simplified expression to calculate the peak magnetic field contributed by a nearby lightning strike [1], [4-5]. For instance a 50 kA strike at 10 meters would contribute a magnetic field of 795 (Amperes/meter) A/m. To determine the induced voltage which can be contributed to by a lightning related magnetic field, the rise time is key as depicted in (2). This rise time varies from $1.4 \mu\text{s}$ to 50 ns depending on which component of lightning is active (initial severe stroke, return stroke, multiple stroke or multiple burst). For most launch sites, the range data includes strike magnitude and location (within a 250 to 500m accuracy), but does not include rise time information. [3] reports the change of magnetic field with respect to time for a near lightning strike 10 m away as $2.2 \times 10^9 \text{ A/m/s}$ and will be used here for example.

$$\text{Max } V_{oc} = \frac{d(\mu H A)}{dt} = \mu(2.2 \times 10^9)(0.2) = 552.9 \text{ V}$$

Where:

(2)

μ = free space permeability = $4\pi \times 10^{-7} \text{ H/m}$

The differential circuit voltage is less than predicted by (2) due to actual circuit impedances and common mode rejection, however the remaining voltage is undesirable for most spacecraft instrumentation circuits. Typical spacecraft retest criteria is 10 – 50 volts, however, lower sensitivities have been reported by design constrained payloads. This retest criteria is important because only minimal on-pad testing is possible due to limited interface controls. Triggering of this criteria can lead to payload destack and return to processing facilities where mission specific testing can ensue. False indications of this trigger based on the assumption of zero shielding in composite fairings is costly from a budget and schedule standpoint. Albeit the consequences of unnecessary retest are severe, the repercussions of an undetected failure are irreversible. As there is no possibility to retrieve a payload on orbit, a conservative, yet easily implementable prediction of shielding to indirect lightning effects is desired.

Test data and two-dimensional numerical models are presented in the literature for a single composite panel in otherwise conductive enclosures, which show significant shielding to the transient lightning pulse [6-8]. The diffusion of direct strikes through composite walls is addressed in evaluation of composite aircraft in [1]. The diffusion of an incident magnetic field for an infinite thin metal plate is also discussed in the literature [9]. For incident pulse times shorter than field diffusion times, internal field amplitude reduction due to energy spreading in time is achieved [9]. Spacecraft developers and launch vehicle providers have questioned the applicability of panel only studies to the launch vehicle fairing structure. The specific objection is the relation of single composite panels surrounded by an otherwise metallic box to launch vehicle enclosures without comparable metallic structures. This study addresses shielding of a composite graphite fairing-like structure to the induced effects of nearby lightning strikes. A physical fairing fixture model is built and test validation is performed to baseline the model. A frequency domain model is also developed for comparison to standard frequency based shielding effectiveness measurements. This is important to both understand the diffusion process and to address the limitations of such induced shielding effects for

magnetically sensitive payloads. This composite structure evaluation is implemented via a commercially available tool for modeling electromagnetic effects in complex structures. In this paper, the frequency domain effects of magnetic fields in a composite cavity are examined. Additional work has been performed in the time domain and presented in a separate paper.

II. FAIRING FIXTURE AND CONFIGURATION

A launch vehicle representative fairing fixture was designed and developed by the University of Mississippi/Analex and is shown in Fig. 2 [10,11]. This fairing fixture model was used in all simulations performed in this work. The fairing fixture is made of two composite fairing halves with tabs at the edges for clamping the fairing enclosure. Two 1 mm 4 ply layers of carbon composite material sandwich a 6.35 mm Rohacell[®] WF foam core with dimensions of the sample shown in Fig.2. Rohacell[®] WF is a closed-cell rigid foam based on polymethacrylimide chemistry, which does not contain any Carbon Fiber Composites (CFC's). This foam core is often utilized in manufacturing advanced composites for aircraft, launch vehicle and spacecraft structures [10]. The composite fairing structure was grounded via a metallic flat plate which interfaced with the bottom edges of the fixture. Surface resistivity of this sample was measured at 161 mohms. For both modeling and test, a sensor is placed 1 meter high in the center of the fairing (see Fig. 2). The baseline case is obtained from measurements with no fairing in place. In the frequency domain, a small loop was used to provide external excitation and internal sensing at specific frequencies. One half of the fairing contained a removable window with metal reinforcing. In one test configuration the fairing was rotated such that the window was placed in between the sensor and the source. This test was performed in order to determine how metal lined apertures, that are typical in launch vehicles, affect the composite fairing overall shielding effectiveness to lightning induced effects.

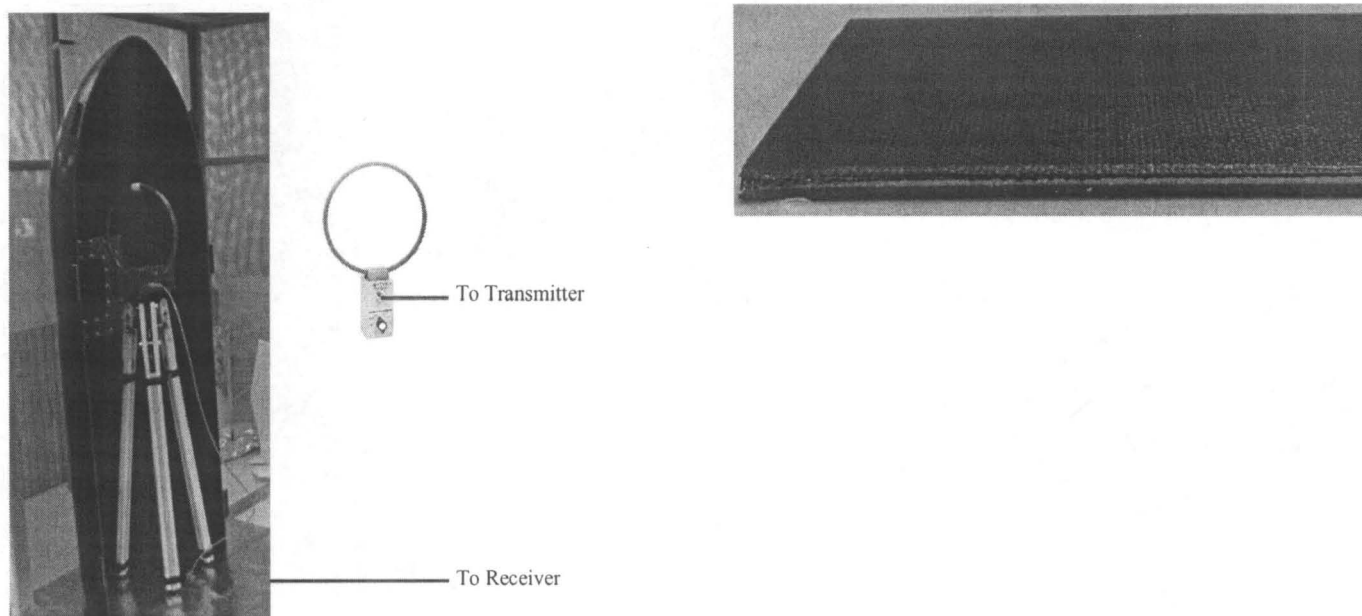

Fig. 2. Side view of graphite composite sample and Test Configuration

III. NUMERICAL MODELS

A method of moments model is used to determine the shielding effectiveness of the fairing.

Modeling the layers of the composite fairing as a dielectric requires the mesh to be small with respect to the thickness of each layer and is computationally prohibitive with respect to the entire model size. Accordingly, the structure is represented as an electromagnetically penetrable thin film with conductivity parameters developed from surface resistivity measurements [12]. To implement the thin film model, the Pro-E input file, which included the material thickness, was converted to a surface only model.

A. Frequency Domain

The frequency domain analysis simulation was performed using electromagnetic simulation software, EM Software & System's FEKO [13] and an imported Pro-E fairing model. The equivalent layer model was implemented with an infinitely thin impedance sheet representing the direct surface impedance measurement. The impedance sheet is "effectively the ratio between the tangential electric field on the surface and the electric surface current" [14]. The default mesh size assigned by the program, which is based on frequency, was changed to account for geometry details. A magnetic loop was implemented as the excitation

source and placed external to the fairing at the same location as the test antenna. Near field measurements were requested at the center vertical sheet in the fairing.

IV. RESULTS

Method of moment simulations were developed at specific frequencies shown in results section. The resulting shielding effectiveness was normalized with respect to the no-fairing structure case. Results and Comparisons

1 shows an excellent agreement between the results of industry test data and the double exponential analytical model.

A. Frequency Domain Results

Results of frequency domain analysis are compared to the fairing fixture test results. An example of the frequency domain analysis near field contour plot is provided in Fig. 3. Part a of the figure represents the near magnetic field at the center plane location with no fairing present.

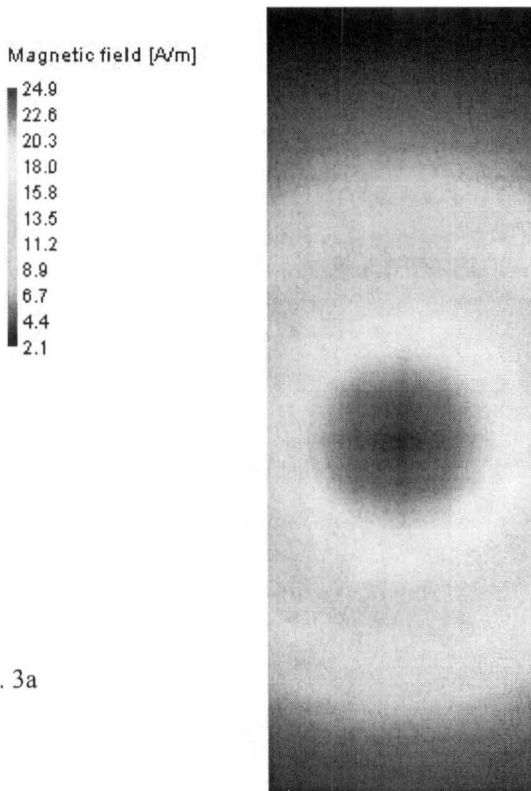

Fig. 3a

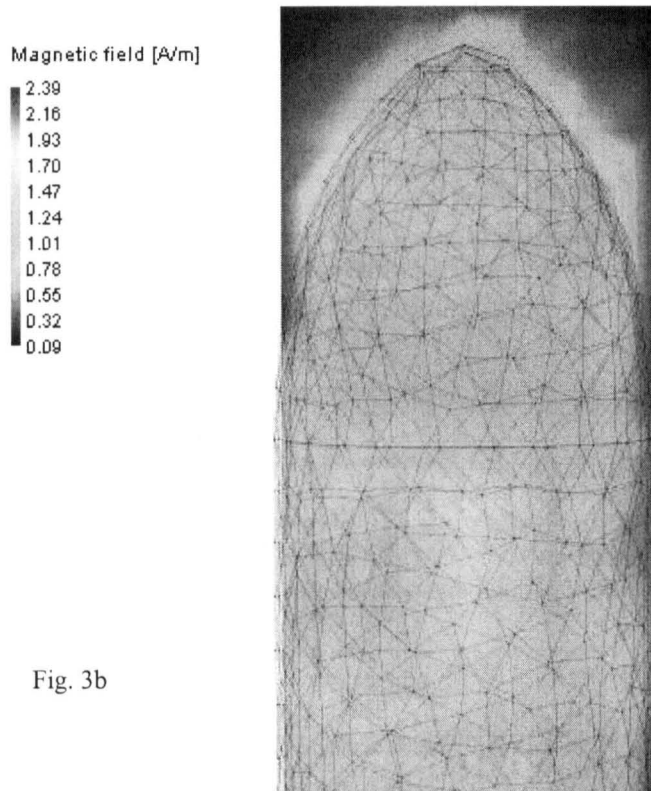

Fig. 3b

Fig. 3 a and b: Results of frequency domain model (no fairing versus composite fairing at 10 MHz)

Part b represents the same plane with the fairing present at 10 MHz, where the redistribution of fields due to fairing structure is evident. The frequency domain test results are shown in Fig. 4. These results show that the test with the metal reinforced aperture in the front of the sensor further reduces the fields measured inside the cavity. The peak improvement is 14 dB at 5 MHz.

The frequency domain simulation-to-test comparisons are shown in Table I. The shielding effectiveness is minimal at the low frequency cases and increases in the MHz range. The data point at 15 MHz deviates from the simulation data, which can be explained by the absence of seams between the fairing halves in the model. The seam length approaches a quarter wavelength at this frequency and thus the limits of this test set-up are reached. Sealing the fairing with copper tape caused a increase in shielding effectiveness, however, it is the desire of this study to isolate the composite fairing effects without the benefit of metallic supporting structures.

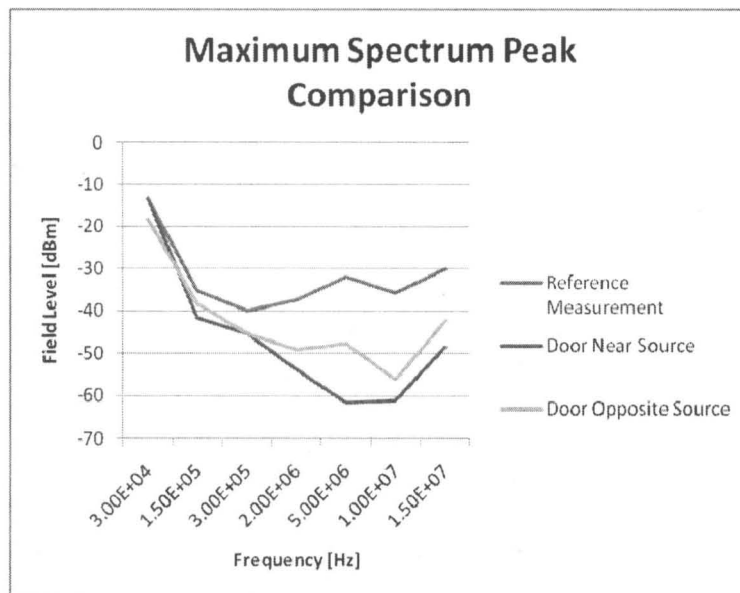

Fig. 4. Frequency response comparison test results (magnetic field as a function of frequency)

The diffusion process is revealed in the frequency domain comparisons. As seen in Table I, shielding increases significantly at 2 MHz and beyond where the skin depth of the material is on the order of the material thickness.

TABLE I
FREQUENCY DOMAIN SHIELDING COMPARISONS

Frequency	Shielding Effectiveness (Test Data) dB	Shielding Effectiveness (Model Data) dB	Difference dB
150 kHz	2	0.9	1.1
300 kHz	5	0.8	4.2
2 MHz	11	10	1
5MHz	17	19.5	2.5
10 MHz	21	21.9	0.9
15 MHz	12	22.3	10.3

Time simulations in the FEKO post-run analysis were used to show the diffusion process. A time step progression of the frequency domain model at 10 MHz is provided in Fig. 5.

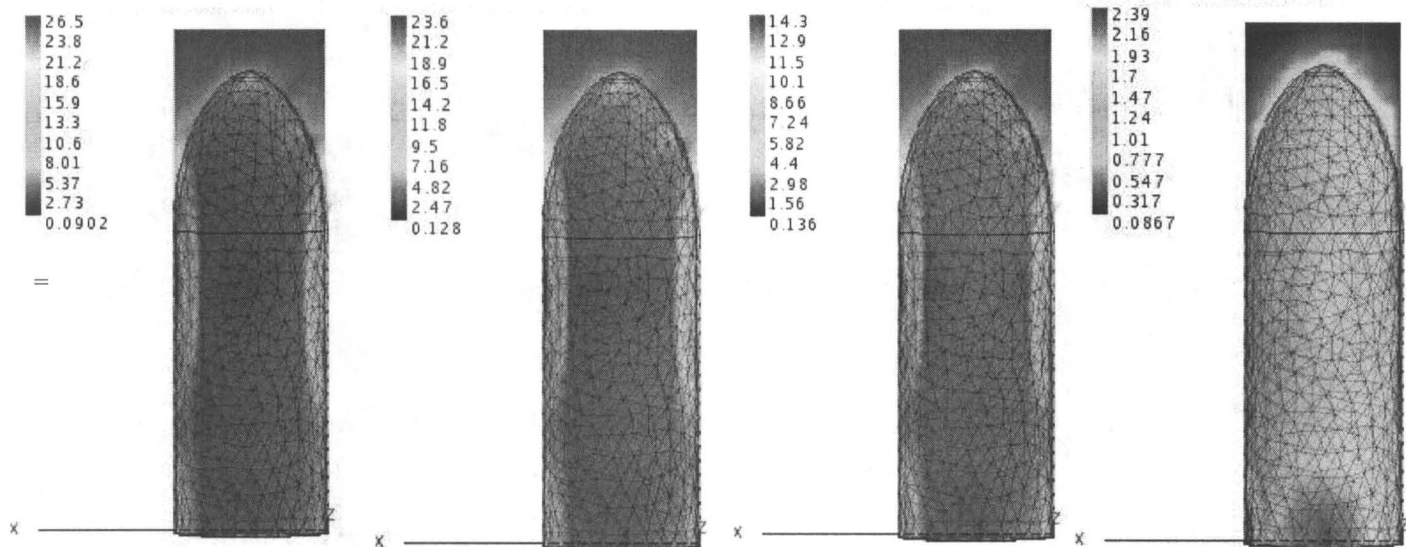

Fig. 5. Time progression of frequency domain model at 10 MHz. Instantaneous H-Field in Y-vertical and X-horizontal plane (0, 30, 60, 90 phase)

V. SUMMARY AND CONCLUSION

It was shown in this work that the analytical model can adequately predict lightning indirect effects. Test results from this paper as well as industry composite panel test results are well simulated using this model. The thin film modeling of the composite structure is shown to be effective in frequency domain simulations of graphite composite fairing structures.

Both model and test data show that although there is negligible attenuation at low frequencies from these graphite composite structures, they provide attenuation to high frequency magnetic fields and to lightning transient pulses. Shielding of these structures occurs due to energy time spreading of the pulse in the diffusion process. The results indicate that launch vehicle graphite composite fairing structures, which include metal reinforcement around apertures, will improve shielding effectiveness beyond the results of the graphite composite fairing alone.

ACKNOWLEDGMENT

This effort could not have taken place without the ingenuity of Dr. Ellen Lackey and Dr. Elliott Hutchcraft from University of Mississippi who developed this low cost composite fairing, the test planning and implementing efforts of Tung Doan and Ron Brewer, and the consultation of Dr. C.J. Reddy.

REFERENCES

- [1] F. A. Fisher, R.A. Perala, J. A. Plumer, *Lightning Protection of Aircraft*, Lightning Technologies Inc., 1990, pp. 306-331.
- [2] K. Javor, *Introduction to the Control of Electromagnetic Interference*, EMC Compliance, 1993.
- [3] Mil-Std-464, *Electromagnetic Environmental Effects Requirements for Systems*, Department of Defense.
- [4] V.A. Rakov, M.A. Uman, *Lightning Physics and Effect*, Cambridge University Press, 2003.
- [5] C. A. Balanis, *Advanced Engineering Electromagnetics*, John Wiley and Sons, New York, 1989.
- [6] R.W. Evans, *NASA Contractor Report 4783, Test Report – Direct and Indirect Lightning Effects on Composite Materials*, Space Environment Effects Program, July 1997.
- [7] M. S. Sarto, "A new model for the FDTD analysis of shielding performance of composite structures," *IEEE Transactions on EMC*, vol 41, no. 4, pp. 298-306, November 1999
- [8] M. S. Sarto, "Hybrid MFIE/FDTD analysis of the shielding effectiveness of a composite enclosure excited by a transient plane wave," *IEEE Transactions on Magnetics*, vol. 36, no. 4, pp 946-950, July 2000.
- [9] F. M. Tesche, M. Ianoz, T. Karlsson, *EMC Analysis Methods and Computational Models*, John Wiley and Sons, Dec. 1996, pp 510-535.
- [10] J. Stanley, *Indirect Lightning Effects Analysis For A Graphite Composite Structure*," Center Director Discretionary Fund Report, Analex Corporation, Sep. 2009.
- [11] D. H. Trout, P. F. Wahid, J. E. Stanley, "Electromagnetic cavity effects from transmitters inside a launch vehicle fairing," *IEEE EMC Symposium*, pp 70-74, Austin, TX, August 17-21, 2009 Paper 978-1-4244-4267-6/09 2009 IEEE.
- [12] C. L. Holloway, M. S. Sarto, M. Johansson, "Analyzing carbon-fiber composite materials with equivalent-layer models", *IEEE Transactions on EMC*, vol. 47, no. 4, pp 833 – 844, Nov. 2005.
- [13] FEKO Quarterly, Field computations involving objects of arbitrary shape, Quarterly, March 2005
- [14] *IEEE Standard Method for Measuring the Effectiveness of Electromagnetic Shielding Enclosures*, IEEE Std 299, 2006.

Evaluation of Lightning Induced Effects in a Graphite Composite Fairing Structure (Part 2)

Dawn Dawn H. Trout^{#1,*1}, James E. Stanley^{#3}

Parveen F. Wahid^{#2},

[#] *School of Electrical Engineering and Computer Sciences*

University of Central Florida, Orlando, FL 32816-2450, USA

¹dawn.h.trout@knights.ucf.edu, ²wahid@eeecs.ucf.edu

School of Electrical and Computer Engineering

Florida Institute of Technology

Melbourne, FL 32901, USA

³jes@fit.edu

^{*} *Kennedy Space Center*

VA-H3

Kennedy Space Center, FL 32899, USA

¹ dawn.h.trout@nasa.gov

Abstract— This paper is the second part in a two part series to examine the lightning induced effects in a graphite composite fairing structure. The first paper provided background on the induced lightning effects issue that spacecraft developers face, described a composite fairing fixture, and revealed comparisons between test and simulation data in the frequency domain. This paper examines the time domain based effects through the development of a loop based induced field testing and a Transmission-Line-Matrix (TLM) model is developed in the time domain to study how the composite fairing affects lightning induced magnetic fields. Comparisons are made with shielding test results obtained using a vehicle-like composite fairing in the time domain. The comparison results show that the analytical models can adequately predict the test and industry results.

Index Terms—composite, magnetic, TLM, lightning, shielding

I. BACKGROUND

As discussed in Part 1, the environment inside a composite fairing due to lightning is a concern to spacecraft developers. The first paper described the fairing fixture, although some details are repeated here for convenience. The goal of this paper is to examine the time domain effects of the graphite composite structure on lightning induced magnetic fields.

II. FAIRING FIXTURE AND CONFIGURATION

The fairing fixture also introduced in Part 1 is shown in Fig. 1 [1,2]. This fairing fixture model was used in all simulations performed in this work. The fairing fixture is made of two composite fairing halves with tabs at the edges for clamping the fairing enclosure. Two 1 mm 4 ply layers of carbon composite material sandwich a 6.35 mm Rohacell[®]WF foam core with dimensions of the sample shown in Fig. 3. Rohacell[®]WF is a closed-cell rigid foam based on polymethacrylimide chemistry, which does not contain any Carbon Fiber Composites (CFC's). The composite fairing structure was grounded via a metallic flat plate which interfaced with the bottom edges of the fixture. Surface resistivity of this sample was measured at 161 mohms. For both modeling and test, a sensor is placed 1 meter high in the center of the fairing. The baseline case is obtained from measurements with no fairing in place. In the time domain model, a large loop driven with a 10 μ sec transient pulse was implemented for the source, and a B-dot sensor was employed to measure the change in magnetic field with respect to time. The loop was selected rather than a high voltage source for ease of implementation in the laboratory setting. A 16 gauge wire enclosed by a PVC supporting structure was used as the current loop.

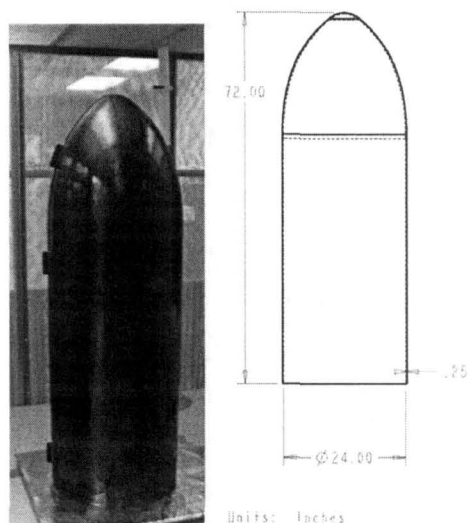

Fig. 1. Physical fairing fixture and dimensions

III. NUMERICAL MODELS

Given the limited frequency content in lightning transient pulses, the TLM tool in CST Microstripes is optimally applied for this electrically small structure. TLM divides the physical space into circuits that can be solved for voltages and currents that are related to fields through analogies to Maxwell's equations [3]. The current source is proximally placed with respect to the fairing for lowest magnetic near field impedance characteristics and thus worst (minimal) shielding of composite structure. The distal leg of current loop is selected as far as possible away from fairing in order to limit field cancellation effects as shown in Fig. 2. Mesh size was set at 30 % greater than the structure with absorbing boundaries for top and side walls. The lower mesh boundary was flush with the structure and set to an electric wall to simulate the ground.

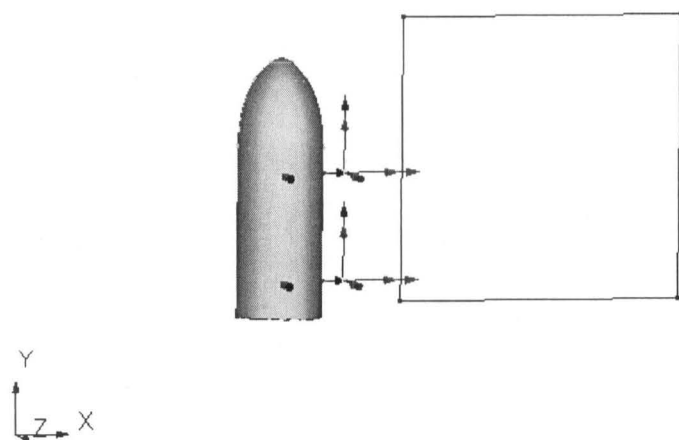

Fig. 2. Time domain model of fairing fixture with loop

Modeling the layers of the composite fairing as a dielectric requires the mesh to be small with respect to the thickness of each layer and is computationally prohibitive with respect to the entire model size. Accordingly, the structure is represented as an electromagnetically penetrable thin film with conductivity parameters developed from surface resistivity measurements [4]. To implement the thin film model, the Pro-E input file, which included the material thickness, was converted to a surface only model.

Although CFC structures are inhomogeneous and tensor formation of permittivity and permeability are needed for accurate representation of electromagnetic shielding, the frequency range of lightning is generally below the interlayer resonance of composite structures, allowing an effective one layer representation of the composite fairing [5,6]. Instead of representing the material thickness with a computationally expensive volume based mesh, the thickness is characterized in terms of skin depth using a thin film implementation [4].

Literature supports modeling composite materials as a single layer if the period of the structure is small with respect to wavelength [5]. This criteria is clearly met with a one cm structure thickness and lightning content below 30 MHz [7]. Several composite builds can effectively be modeled as one layer into the GHz frequency range [5].

As a composite material is not uniform, the volume conductivity cannot entirely be determined from the surface conductivity and thickness. If there are several layers of composite materials, then multiple orientation of the fibers will exist, and the standard volume resistivity calculated from surface resistance will approximate the actual conductivity [8]. The conductivity for the graphite composite layer was modeled with the uniform material assumption and calculated using (1).

$$\sigma = \frac{1}{\rho} \quad \rho = R_s t$$

$$\sigma = \frac{1}{(161 \text{ mohm})(1 \text{ mm})} = 6211 \text{ s/m}$$

Where:

σ = conductivity in s/m

ρ = volume resistivity

R_s = surface resistivity

t = thickness

(1)

Two loop excitation waveforms were modeled. One model, shown in Fig. 3 was designed to closely characterize the transient generator pulse that could be implemented with spike generator into an inductive loop. The other excitation waveform, shown in Fig. 4, represents the industry standard double exponential lighting pulse typically specified in lightning standards [14]. The points of maximum change in magnetic field are of primary interest to determine the worst case induced voltages as evidenced in (2). In experimental test pulse with 3 μ s rise time is evaluated for change in magnetic field amplitude over the rise time period (see Fig 5). The double exponential signal peak change in magnetic field was found to occur between 0.2 μ s and 0.4 μ s and is shown in Fig. 6. This portion of the curve was used in shielding effectiveness comparisons to consider the composite fairings response to the most rapid magnetic field changes. The difference in the peak change in magnetic field with respect to time, with and without the fairing, represents the shielding effectiveness (SE) of the fairing as in (2) Although classic definitions of shielding effectiveness are based on the magnitude of the field, the intent of this effort is the indirect effects coupled voltages related to the change in magnetic field with respect to time are considered. Accordingly slopes of the magnetic field are used to evaluate the effectiveness of the fairing to protect the spacecraft from induced voltages.

$$SE = 20 \log \left[\frac{Hnf_{t_2} - Hnf_{t_1}}{t_2 - t_1} \bigg/ \frac{Hf_{t_2} - Hf_{t_1}}{t_2 - t_1} \right] \quad (2)$$

where

Hnf_{t_2} = Magnitude of Hfield without fairing at time t_2

Hf_{t_2} = Magnitude of Hfield with fairing at time t_2

The TLM model frequency span is set to 20 MHz for broad band evaluations, and the structure mesh size is driven by this frequency. The run time duration is extended beyond the default settings to account for the total waveform time. The laboratory loop was modeled with a 10 ohm load impedance to partially account for the inductance created by the loop. A 100 volt transient pulse source was applied to a loop with conductivity set to emulate the test configuration of 5.87×10^7 s/m with a radius of 0.15 cm. The loop impedance was then altered to be closer of the industry lightning indirect effects test case by setting the resistance to zero and applying a 10,000 volt driven double exponential current source. The double exponential source characteristics based on MIL-STD-464 was $i(t) = I_0(\cdot e^{-\alpha t} - e^{-\beta t})$, where $I_0 = 218,810$ A, $\alpha = 11,354$ s⁻¹, and $\beta = 647,265$ s⁻¹.

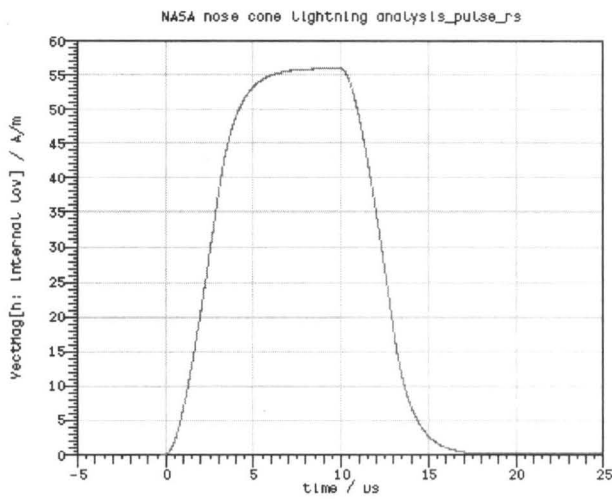

Fig. 3 Transient generator loop excitation waveform

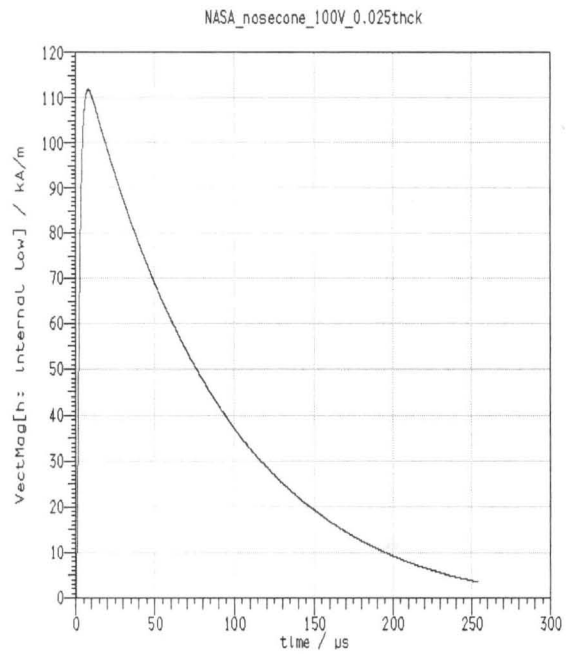

Fig. 4. Double exponential loop excitation waveform

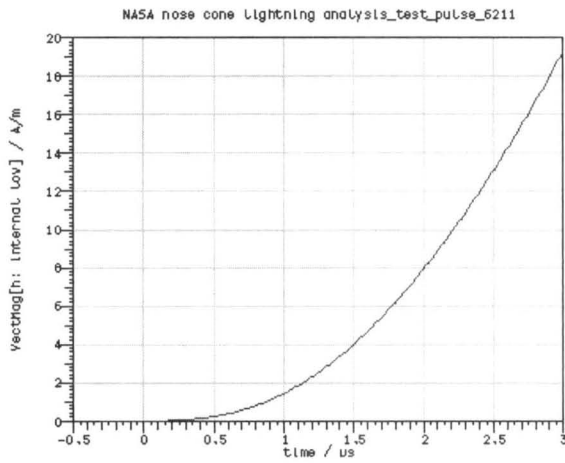

Fig. 5. Test pulse with composite test fairing (magnetic field strength as a function of time).

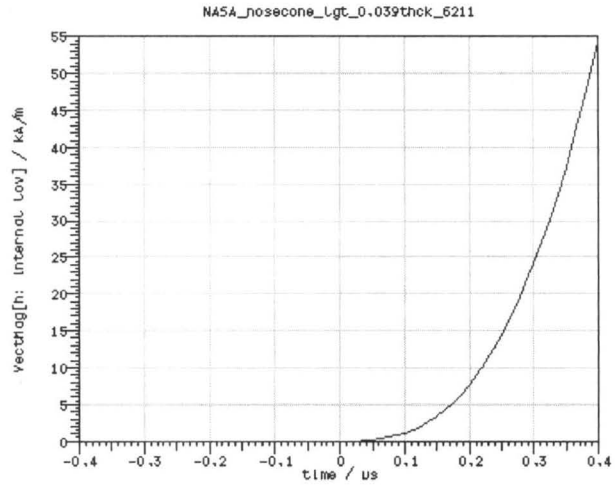

Fig. 6. Double exponential magnetic field with composite test fairing (magnetic field strength as a function of time).

The fairing model was further modified in order to compare to the results of industry panel testing. The modifications included using the characteristics of industry graphite composite panels in the fairing fixture model. The two panels selected for modeling had a conductivity of 11,600 S/m and thicknesses of 0.25 cm and 0.76 cm [2,8].

IV. RESULTS AND COMPARISONS

A. Time Domain Results

The results of the time domain TLM analysis were compared to the fairing fixture test data and then compared to industry panel-only test results after updating the model with the properties of the industry panels. A brief description of the industry test is provided for completeness. The time domain comparisons are shown in Table 1.

The time domain model predicts similar shielding effectiveness to the change in magnetic field as the test case with less than one dB difference. The same model with the double exponential pulse for excitation indicates higher shielding effectiveness. In this case the faster rise portion of the curve was evaluated and the higher attenuation of these fields was found to be reasonable. Literature evaluation of Gaussian and double exponential transient pulse shielding of composite structures showed similar dependence on the pulse type [4].

Conductivity and thickness values from industry graphite composite panels were used as inputs to the TLM model for further validation [13]. The industry test in Reference [2] was performed with a B-dot sensor in a metal box with the front wall as a removable panel. A lightning source was exercised directly in front of the removable panel. A fiberglass panel was used for the no-shielding case to compare with the shielding achieved with graphite composite panels [2]. The TLM time domain model shown in Fig.2 modified with the material properties of the industry test panels showed attenuation of the rate of change of magnetic field in the fairing comparable to industry data [7, 9 & 10]. Table 1 shows an excellent agreement between the results of industry test data and the double exponential analytical model.

TABLE I
TIME DOMAIN COMPARISONS

Configuration	Pulse Type	Analytical Shielding (dB)	Test Shielding
Fairing Fixture	Spike Generator Pulse	8.06	7.4
Fairing Fixture	Double Exponential	21.9	---
Industry Graphite 0.098 inches	Double Exponential	42	42.9 – 44.6 (similar panel tests)
Industry Graphite 0.3 inches	Double Exponential	60	---

V. SUMMARY AND CONCLUSION

It was shown in this work that the TLM model can adequately predict lightning indirect effects. Test results from this paper as well as industry composite panel test results are well simulated using this model. The thin film modeling of the composite structure is shown to be effective in the frequency and time domain analyses of graphite composite fairing structures.

Both model and test data show that although there is negligible attenuation at low frequencies from these graphite composite structures, they provide attenuation to high frequency magnetic fields and to lightning transient pulses. Shielding of these structures occurs due to energy time spreading of the pulse in the diffusion process. The results indicate that launch vehicle graphite composite fairing structures, which include metal reinforcement around apertures, will improve shielding effectiveness beyond the results of the graphite composite fairing alone.

ACKNOWLEDGMENT

This effort could not have taken place without the ingenuity of Dr. Ellen Lackey and Dr. Elliott Hutchcraft from University of Mississippi who developed this low cost composite fairing, the test planning and implementing efforts of Tung Doan and Ron Brewer, and the consultation of Dr. David Johns.

REFERENCES

- [1] J. Stanley, *Indirect Lightning Effects Analysis For A Graphite Composite Structure*, Center Director Discretionary Fund Report, Analex Corporation, Sep. 2009.
- [2] D. H. Trout, P. F. Wahid, J. E. Stanley, "Electromagnetic cavity effects from transmitters inside a launch vehicle fairing," *IEEE EMC Symposium*, pp 70-74, Austin, TX, August 17-21, 2009 Paper 978-1-4244-4267-6/09 2009 IEEE.
- [3] M. N.O. Sadiku, *Numerical Techniques in Electromagnetics, Second Edition*, pp. 467-529, CRC Press, Boca Raton, FL, 2001.
- [4] *CST Microstrips Reference Manual*, CST Computer Simulation Technology AG, 2009.

- [5] C. L. Holloway, M. S. Sarto, M. Johansson, "Analyzing carbon-fiber composite materials with equivalent-layer models", *IEEE Transactions on EMC*, vol. 47, no. 4, pp 833 – 844, Nov. 2005.
- [6] J. E. Stanley, D. H. Trout, S. K. Earles, I. N. Kostanic, P. F. Wahid, "Analysis of multi-layer composite cavity using FEKO," 25th Annual Review of Progress in Applied Computation Electromagnetics, pp. 643-647, March 8-12, 2009.
- [7] R.W. Evans, *NASA Contractor Report 4783, Test Report – Direct and Indirect Lightning Effects on Composite Materials*, Space Environment Effects Program, July 1997.
- [8] R.W. Evans, *Design Guidelines for Shielding Effectiveness, Current Carrying Capability and the Enhancement of Conductivity of Composite Materials*, NASA Contractor Report 4784, Space Environment Effects Program, August 1997.
- [9] M. S. Sarto, "Hybrid MFIE/FDTD analysis of the shielding effectiveness of a composite enclosure excited by a transient plane wave," *IEEE Transactions on Magnetics*, vol. 36, no. 4, pp 946-950, July 2000.
- [10] M. S. Sarto, "A new model for the FDTD analysis of shielding performance of composite structures," *IEEE Transactions on EMC*, vol 41, no. 4, pp. 298-306, November 1999

Evaluation of Lightning Induced Effects in a Graphite Composite Fairing Structure (Part 1)

Dawn Trout

James Stanley

Parveen Wahid

Launch Vehicle Lightning

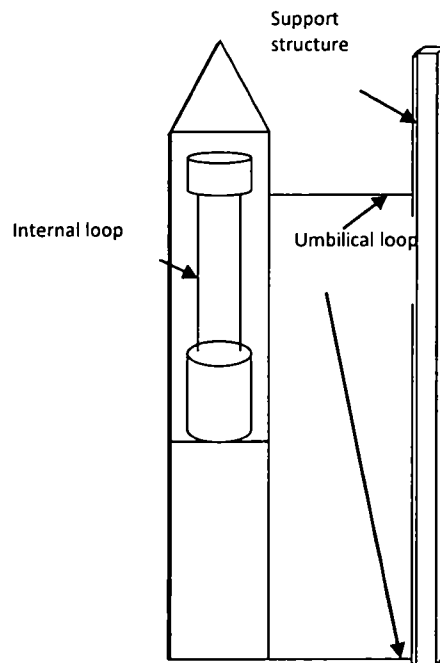

- Umbilical is the primary area of concern for lightning effects. Measurements/suppression are possible in this region.
- Fairing attenuation with respect to lightning is not quantified and a 0 dB worst case is assumed.
- For most launch sites, the range data includes strike magnitude and location (within a 250 to 500m accuracy), but does not include rise time information.
- This rise time varies from 1.4 μ s to 50 ns depending on which component of lightning is active (initial severe stroke, return stroke, multiple stroke, or multiple burst).

Fig. 1. Launch vehicle and umbilical tower or multiple burst).

Magnetic Fields from Lightning

$$\oint H \cdot dl = I_l + I_d = I_l + \int_s \frac{\partial}{\partial t} (\epsilon_0 E) da$$

Where:

H = magnetic field

l = length of loop

I_l = lightning current

I_d = displacement current

E = Electric Field

A = loop area

ϵ_0 = permittivity of free space = $8.85 \times 10^{-12} \text{ F/m}$

- Expect some change in internal fairing electromagnetic effects due to diffusion.
 - For incident pulse times shorter than field diffusion times, internal field amplitude reduction due to energy spreading in time is achieved

Induced Voltage

- MIL-STD-464

- dE/dt 10 m = 6.8×10^{11} (V/m/s) .
- dH/dt 10 m = 2.2×10^9 A/m/s
- For 2 m² circuit area, the contributing portion of the magnetic field due to the displacement current (I_d) is 1.2 A/m .
- In this case, the magnetic field is $I_d/(2\pi r)$, where r is the distance from the strike and $2\pi r$ represents the circumference of the circle with radius, r .
- For instance, a 50 kA strike at 10 meters would contribute a magnetic field of 795 A/m.

$$Max V_{oc} = \frac{d(\mu HA)}{dt} = \mu(2.2 \times 10^9)(0.2) = 552.9V$$

Where :

$$\mu = \text{free space permeability} = 4\pi \times 10^{-7} \text{ H / m}$$

- Spacecraft retest criteria is often 10 – 50 Volts.

Scaled Composite Fairing

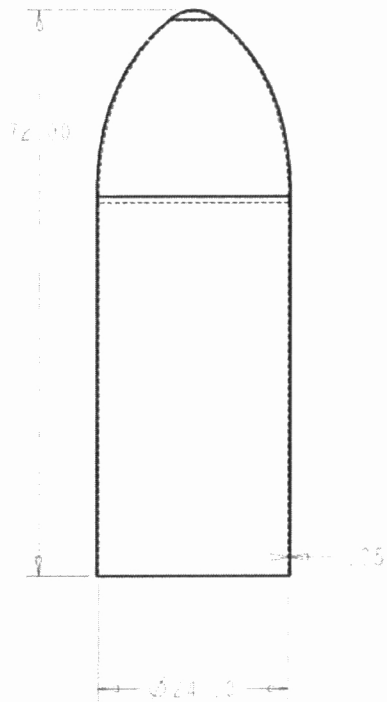

Ln. 350 Inches



Made of two composite fairing halves with tabs at the edges for clamping the fairing enclosure.

Physical fairing fixture and dimensions (1.8 mm x 0.6 m)

Composite Material

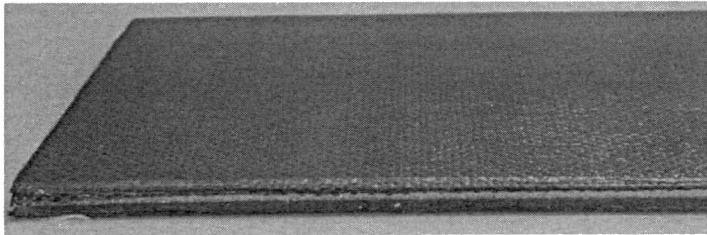

- Two 1 mm ply layers of carbon composite
- 6.35 mm Rohacell[®] WF foam core

$$\sigma = \frac{1}{\rho} \quad \rho = R_s t$$

$$\sigma = \frac{1}{(161 \text{ mohm})(1 \text{ mm})} = 6211 \text{ s/m}$$

Where :

σ = conductivity in s / m

ρ = volume resistivity

R_s = surface resistivity

t = thickness

Frequency Domain Shielding Test

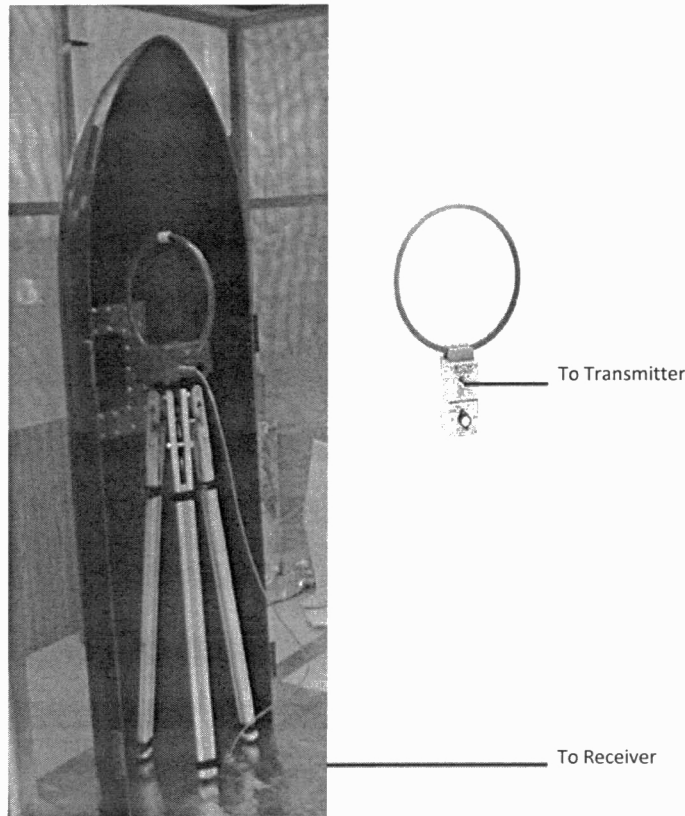

- The composite fairing structure was grounded via a metallic flat plate.
- The baseline case is obtained from measurements with no fairing in place.
- A small loop was used to provide external excitation and internal sensing at specific frequencies.
- One half of the fairing contained a removable window with metal reinforcing.

Fig. 2. Side view of graphite composite sample and test configuration

FEKO MoM Model of Composite Structure at 10 MHz

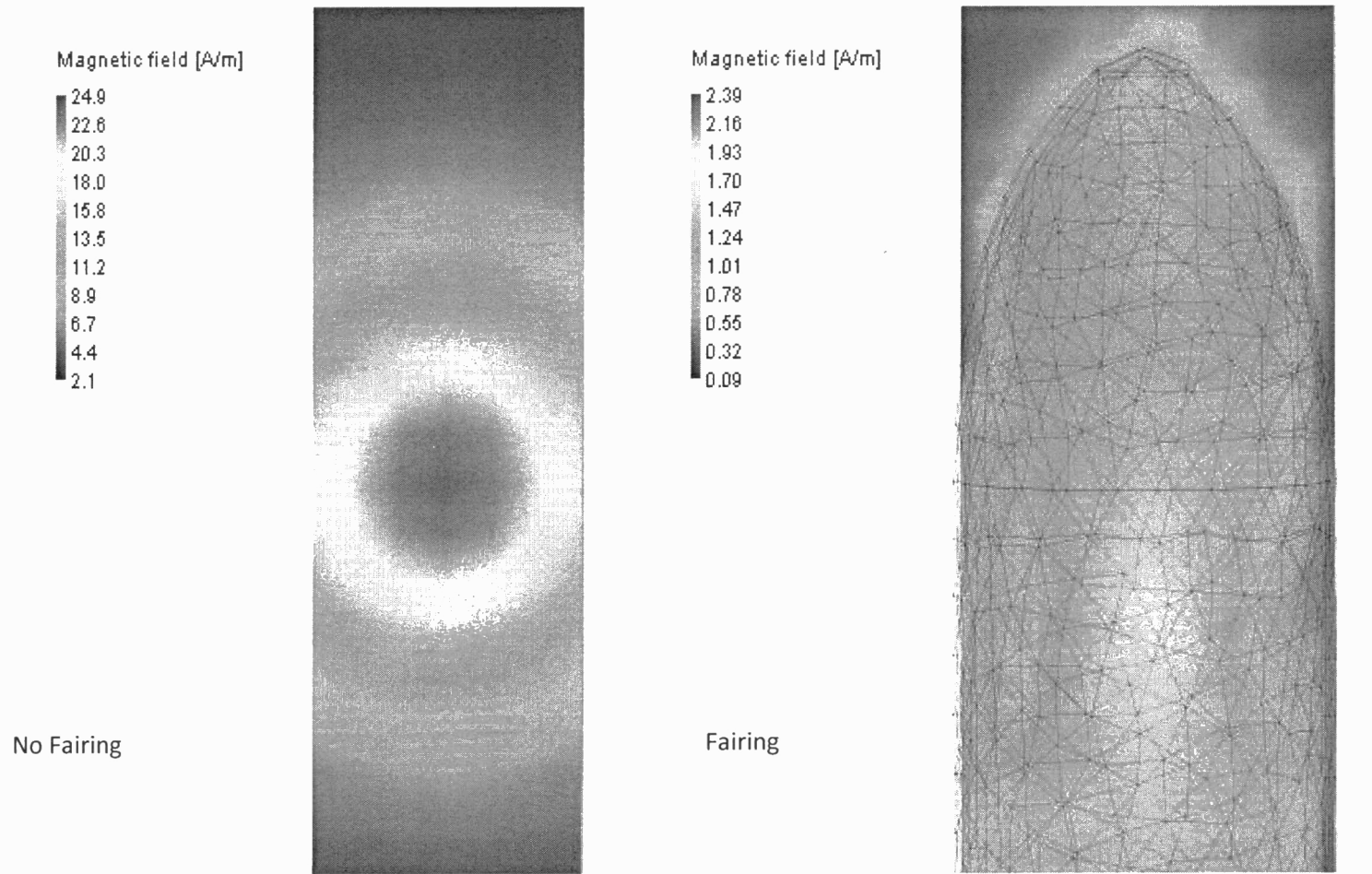

Redistribution of magnetic fields is evident in the MHz range.

Frequency Domain Shielding Test Results

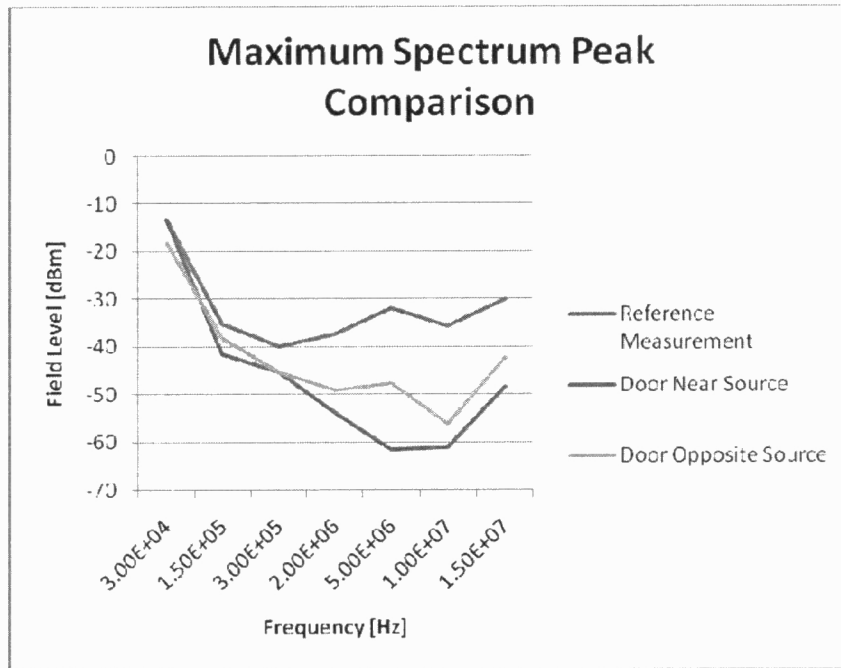

Frequency	Shielding Effectiveness (Test Data) dB	Shielding Effectiveness (Model Data) dB	Difference dB
150 kHz	2	0.9	1.1
300 kHz	5	0.8	4.2
2 MHz	11	10	1
5MHz	17	19.5	2.5
10 MHz	21	21.9	0.9
15 MHz	12	22.3	10.3

Fig. 4. Frequency response comparison test results (magnetic field as a function of frequency) [10].

Magnetic Field versus phase through Composite Structure

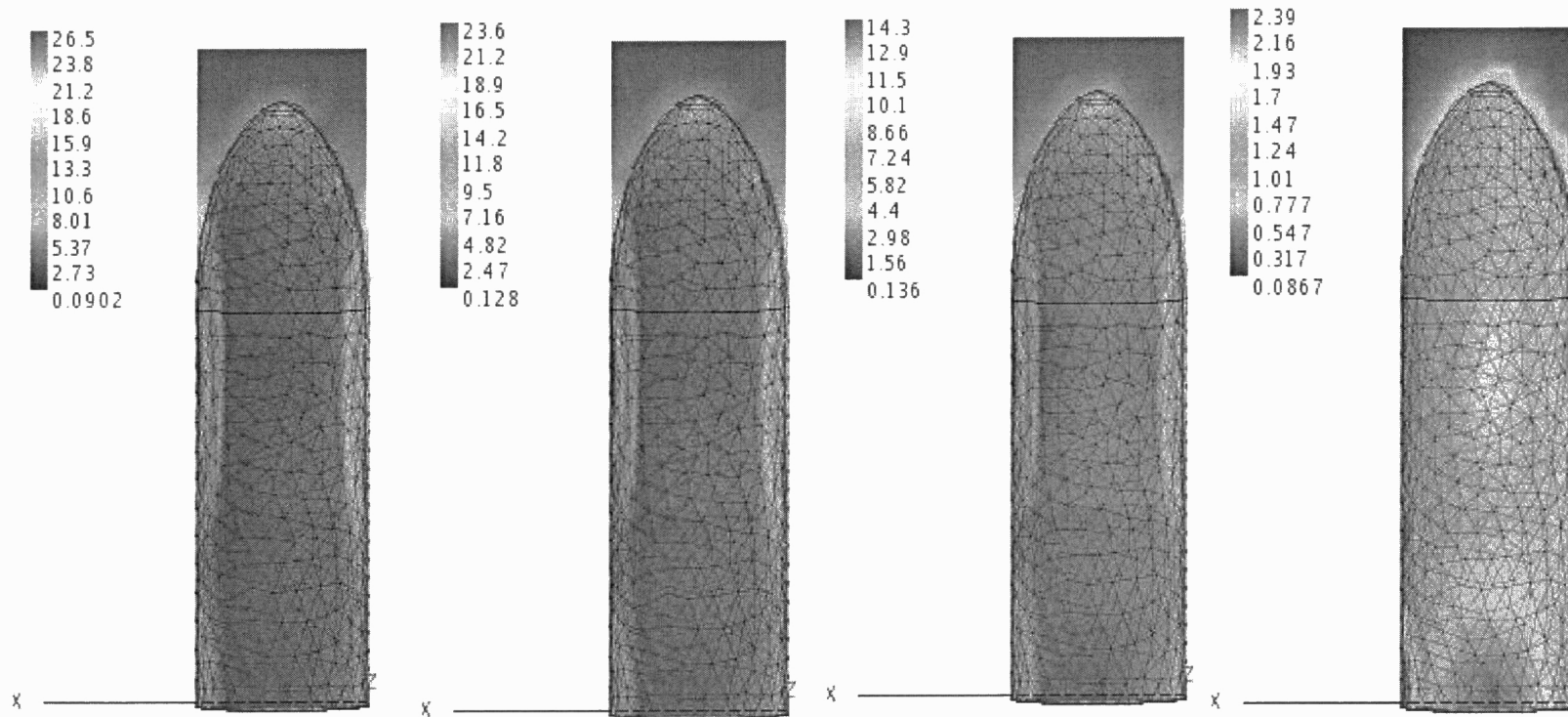

Fig. 5. H-Field in Y-vertical and X-horizontal plane (0, 30, 60, 90 phase) at 10 MHz.

Conclusions

- Launch vehicle lightning Issues were introduced.
- Composite fairing model description was shown.
- FEKO MoM model was examined.
- Frequency domain shielding effectiveness test comparisons were provided.
- Part Two will examine time domain effects of lightning in composite launch vehicle structures.

**Evaluation of Lightning Induced Effects in a Graphite Composite
Fairing Structure (Part 2)**

Dawn Trout

James Stanley

Parveen Wahid

Transient Evaluation

Goal: Reconcile Industry Data regarding Composite Shielding in lightning frequency ranges versus Launch Vehicle 0 dB Shielding Effectiveness

$$V_{ind} = \frac{d}{dt} \iint_A \mu H \cdot d\alpha$$

$$V_{ind} \approx \mu A \frac{d}{dt} H$$

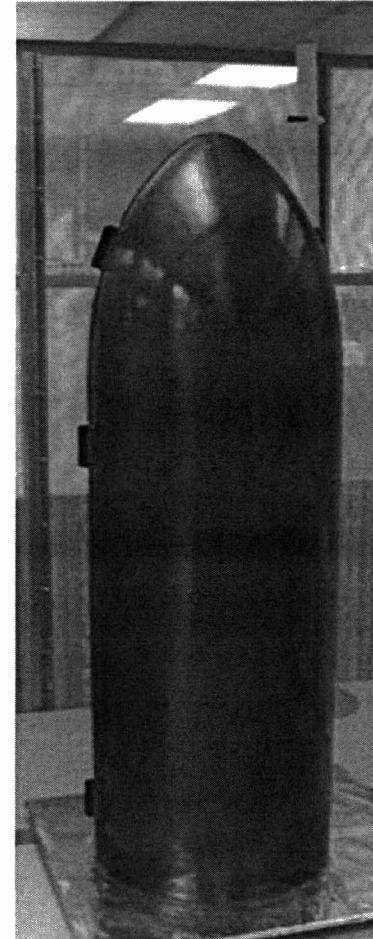

Panel dB/dt Correlation Data

Sample	B-dot Measurement (mV)	Correlation to Fiberglass (dB)
Fiberglass	7.35	62.2
Aluminum	9509	0
1	72.84	42.4
2A	72.84	42.3
3A	12.81	57.4
4A	50.24	45.5
5	55.26	44.6

From NASA CR 4783

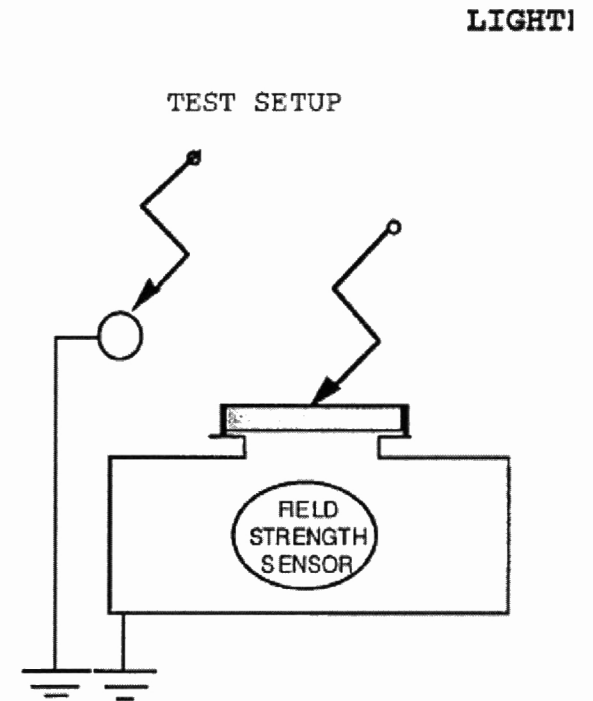

Transmission-line-matrix (TLM) model using Microstripes

- Transient source -Spike generator with 10 μ sec pulse into 2m square 16 gauge wire loop supported by PVC structure.
- Proximal side – 0.5 m from fairing.
- For both modeling and test, the magnetic field sensor location is placed 1 meter from the ground in the center of the fairing.
- Sensor - B-dot 1 meter from base.
- Thin film model – diffusion effects
- Absorbing boundaries – +30 % top and side walls.
- Electric wall for ground plane

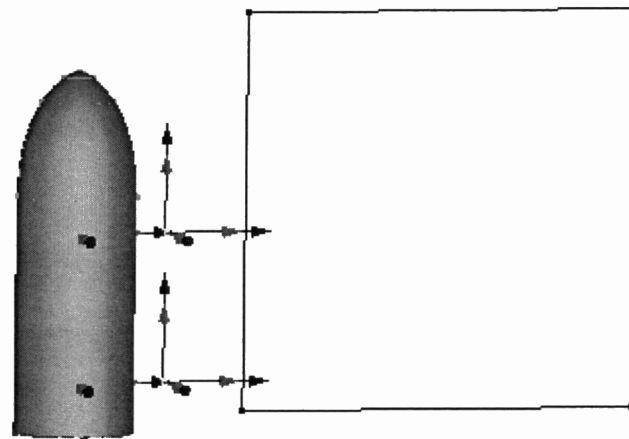

$$i(t) = I_0(e^{-\alpha t} - e^{-\beta t})$$

where, $I_0 = 218,810 \text{ A}$, $\alpha = 11,354 \text{ s}^{-1}$, and $\beta = 647,265 \text{ s}^{-1}$

Excitation waveform

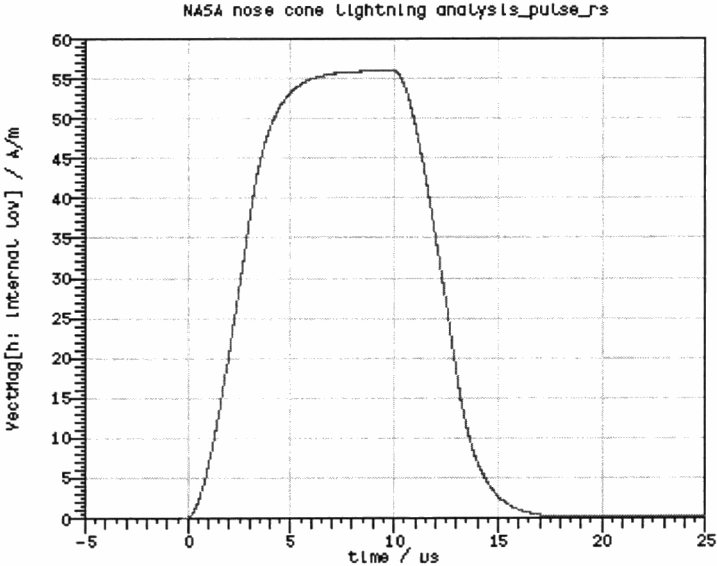

Pulse in test set-up

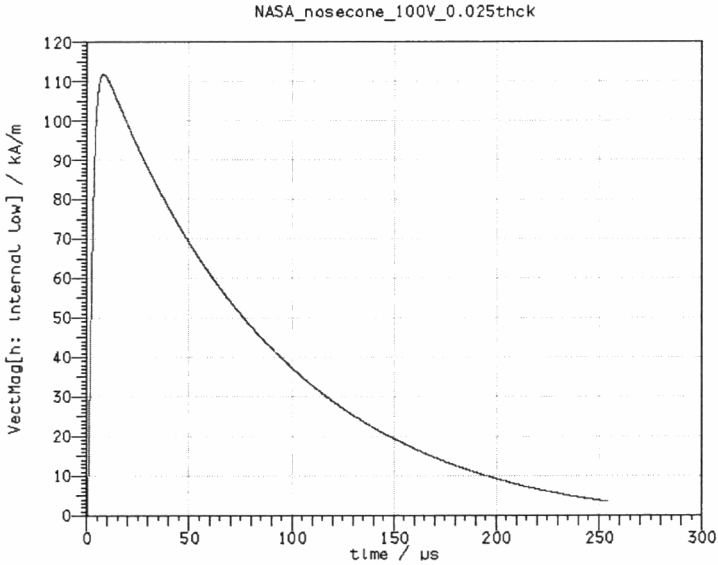

double exponential pulse

Magnetic Field Strength inside fairing

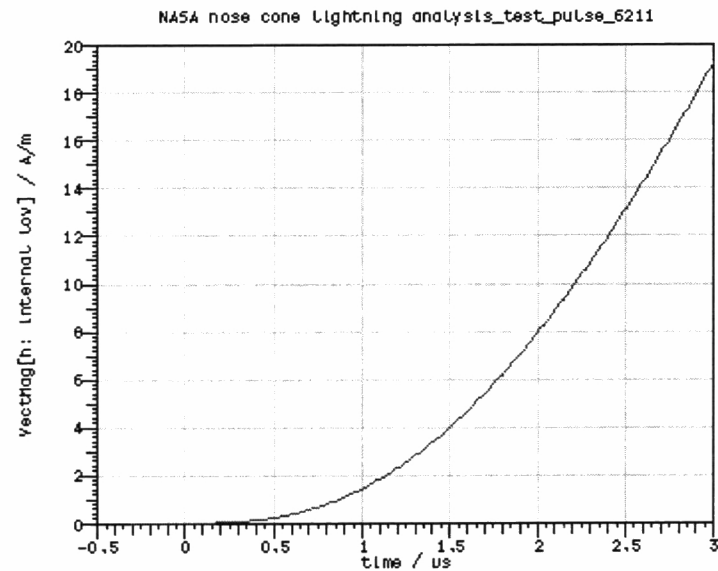

test pulse

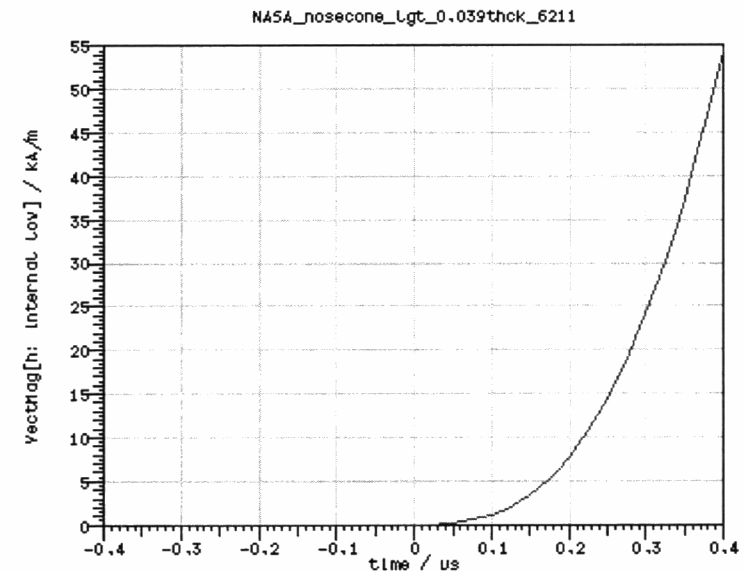

double exponential pulse

Table 1: Time domain comparisons

Change in Magnetic Field Data

$$dH / dt \text{ change} = 20 \log \left[\frac{Hnf_{t_2} - Hnf_{t_1}}{t_2 - t_1} \bigg/ \frac{Hf_{t_2} - Hf_{t_1}}{t_2 - t_1} \right]$$

where

Hnf_{t_2} = Magnitude of Hfield without fairing at time t_2

Hf_{t_2} = Magnitude of Hfield with fairing at time t_2

Configuration	Pulse Type	Simulation dH/dt (dB difference with and without fairing)	Test dH/dt (dB difference with and without fairing)
Fairing Fixture	Spike Generator Pulse	8.06	7.4
Fairing Fixture	Double Exponential	21.9	---

Table 1: Time domain comparisons

Induced Voltage Model

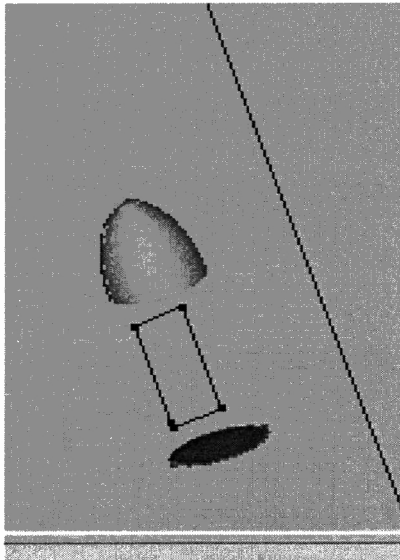

Added loop for induced effects

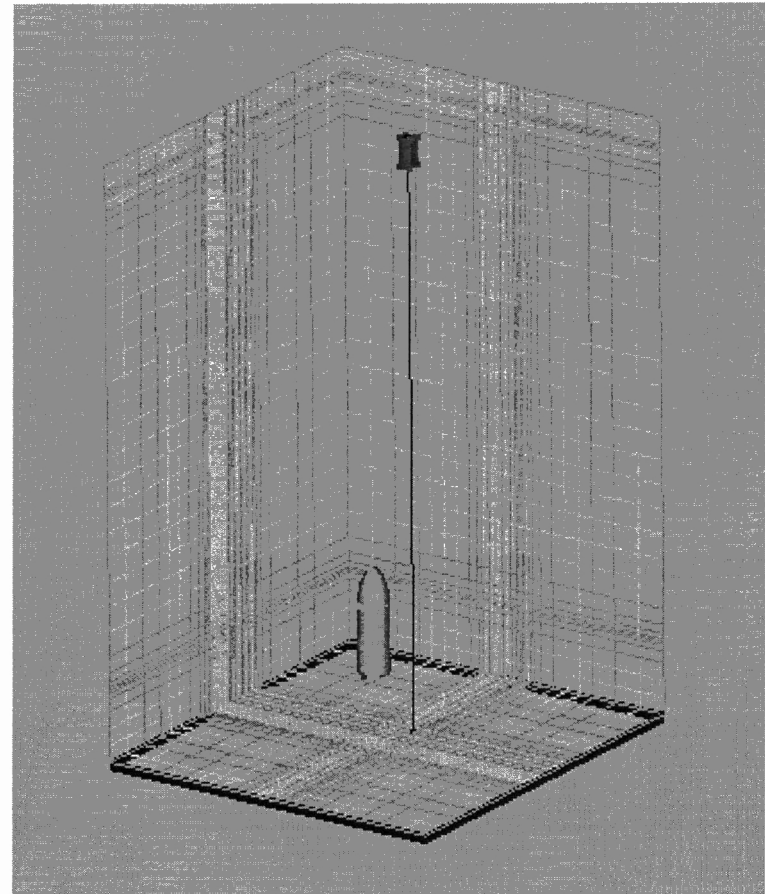

Carl Baldwin Lightning Model CST Microstripes
Presentations

Line Source Magnetic Field and Induced Currents in 0.1 ohm loop

Composite Fairing

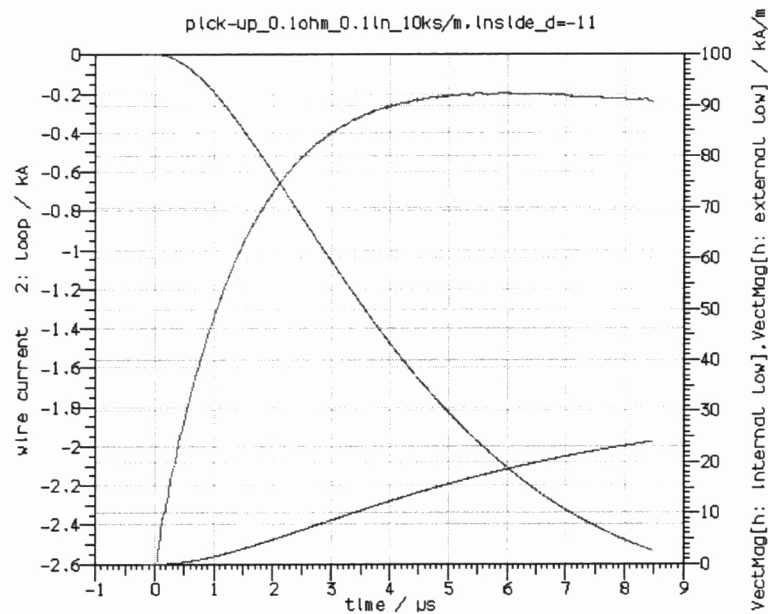

Air

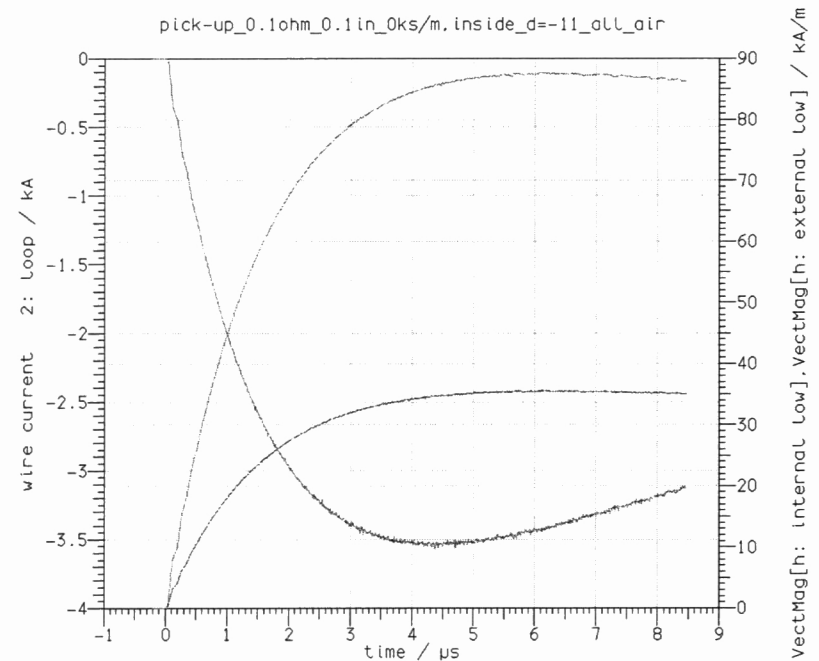

Line Source Magnetic Field and Induced Currents in 1 Mohm loop

Composite Fairing

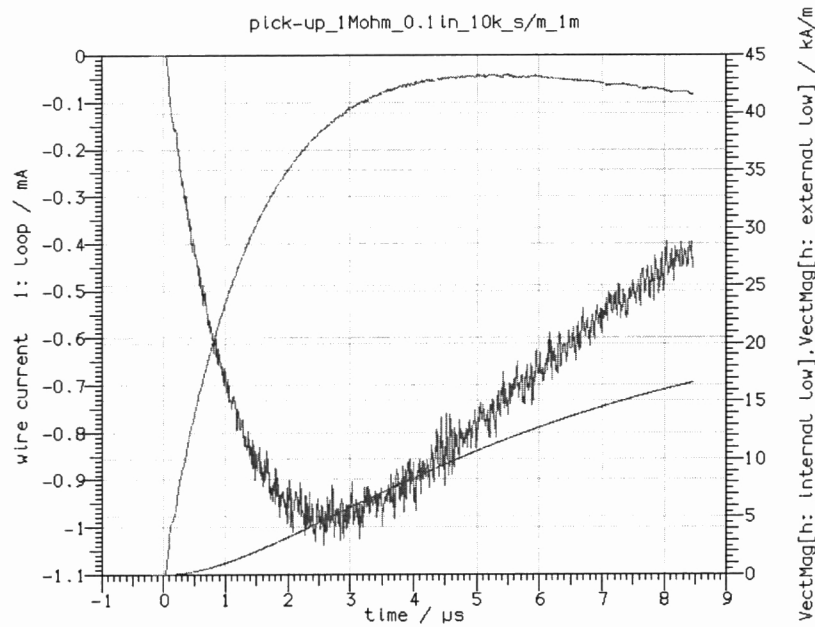

Air

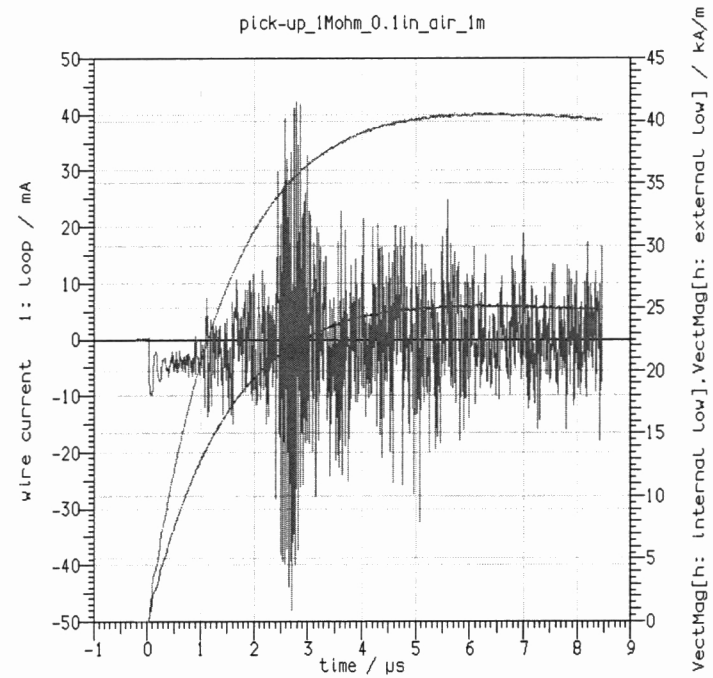

Correlation Data

Distance (m)	0.5 (0.1 Ω)	0.5 (1 M Ω)	1	3	10	100	PW
Vind SE (dB)	2.6	29	32	29	27	38.7	42.6
Hmag SE (dB)	2.9	3.1	3.3	3.5	3.25	3.5	3.5

Conclusions

- Modeled change in magnetic field in composite fairing from large loop transient source.
- Modified model to represent typical lightning strike per industry standard modeling technique.
- Showed reduced induced currents for high impedance loops in typical fairing structure.