

NASA/TM—2010-216906



Experimental Lithium-Ion Battery Developed for Demonstration at the 2007 NASA Desert Research and Technology Studies (D-RATS) Program

*William R. Bennett and Richard S. Baldwin
Glenn Research Center, Cleveland, Ohio*

NASA STI Program . . . in Profile

Since its founding, NASA has been dedicated to the advancement of aeronautics and space science. The NASA Scientific and Technical Information (STI) program plays a key part in helping NASA maintain this important role.

The NASA STI Program operates under the auspices of the Agency Chief Information Officer. It collects, organizes, provides for archiving, and disseminates NASA's STI. The NASA STI program provides access to the NASA Aeronautics and Space Database and its public interface, the NASA Technical Reports Server, thus providing one of the largest collections of aeronautical and space science STI in the world. Results are published in both non-NASA channels and by NASA in the NASA STI Report Series, which includes the following report types:

- **TECHNICAL PUBLICATION.** Reports of completed research or a major significant phase of research that present the results of NASA programs and include extensive data or theoretical analysis. Includes compilations of significant scientific and technical data and information deemed to be of continuing reference value. NASA counterpart of peer-reviewed formal professional papers but has less stringent limitations on manuscript length and extent of graphic presentations.
- **TECHNICAL MEMORANDUM.** Scientific and technical findings that are preliminary or of specialized interest, e.g., quick release reports, working papers, and bibliographies that contain minimal annotation. Does not contain extensive analysis.
- **CONTRACTOR REPORT.** Scientific and technical findings by NASA-sponsored contractors and grantees.

- **CONFERENCE PUBLICATION.** Collected papers from scientific and technical conferences, symposia, seminars, or other meetings sponsored or cosponsored by NASA.
- **SPECIAL PUBLICATION.** Scientific, technical, or historical information from NASA programs, projects, and missions, often concerned with subjects having substantial public interest.
- **TECHNICAL TRANSLATION.** English-language translations of foreign scientific and technical material pertinent to NASA's mission.

Specialized services also include creating custom thesauri, building customized databases, organizing and publishing research results.

For more information about the NASA STI program, see the following:

- Access the NASA STI program home page at <http://www.sti.nasa.gov>
- E-mail your question via the Internet to help@sti.nasa.gov
- Fax your question to the NASA STI Help Desk at 443-757-5803
- Telephone the NASA STI Help Desk at 443-757-5802
- Write to:
NASA Center for AeroSpace Information (CASI)
7115 Standard Drive
Hanover, MD 21076-1320

NASA/TM—2010-216906

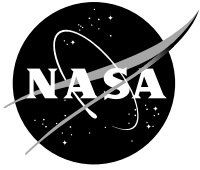

Experimental Lithium-Ion Battery Developed for Demonstration at the 2007 NASA Desert Research and Technology Studies (D-RATS) Program

*William R. Bennett and Richard S. Baldwin
Glenn Research Center, Cleveland, Ohio*

National Aeronautics and
Space Administration

Glenn Research Center
Cleveland, Ohio 44135

November 2010

Acknowledgments

Acknowledgements are given to the following persons for their contributions to this task:

NASA Headquarters

Chris Moore (sponsor)

NASA Glenn Research Center

Gary Horsham

Jerri Ling

Dave Yendriga

NASA Johnson Space Center

Craig Bernard

Edward Ehlers

Kevin Groneman

Judith Jeevarajan

Joseph Kosmo

Barbara Romig

Nathan Smith

Steve Wells

Jet Propulsion Laboratory

Marshall Smart

Kumar Bugga

Trade names and trademarks are used in this report for identification only. Their usage does not constitute an official endorsement, either expressed or implied, by the National Aeronautics and Space Administration.

Level of Review: This material has been technically reviewed by technical management.

Available from

NASA Center for Aerospace Information
7115 Standard Drive
Hanover, MD 21076-1320

National Technical Information Service
5301 Shawnee Road
Alexandria, VA 22312

Available electronically at <http://gltrs.grc.nasa.gov>

Experimental Lithium-Ion Battery Developed for Demonstration at the 2007 NASA Desert Research and Technology Studies (D-RATS) Program

William R. Bennett and Richard S. Baldwin
National Aeronautics and Space Administration
Glenn Research Center
Cleveland, Ohio 44135

Abstract

The NASA Glenn Research Center (GRC) Electrochemistry Branch designed and built five lithium-ion battery packs for demonstration in spacesuit simulators as a part of the 2007 Desert Research and Technology Studies (D-RATS) activity at Cinder Lake, Arizona. The experimental batteries incorporated advanced, NASA-developed electrolytes and included internal protection against over-current, over-discharge and over-temperature.

The 500-g experimental batteries were designed to deliver a constant power of 22 W for 2.5 hr with a minimum voltage of 13 V. When discharged at the maximum expected power output of 38.5 W, the batteries operated for 103 min of discharge time, achieving a specific energy of 130 Wh/kg.

This report summarizes design details and safety considerations. Results for field trials and laboratory testing are summarized.

Introduction

In 2007, NASA Headquarters gave the NASA Glenn Research Center (GRC) Electrochemical Branch the opportunity to demonstrate various elements of the Exploration Technology Development Program (ETDP) as a part of the 2007 Desert Research and Technology Studies (D-RATS) activity at Cinder Lake, Arizona. Early in the project, it was decided that electrolytes, developed by the NASA Jet Propulsion Laboratory (JPL) under the ETDP for low-temperature lithium-ion applications, represented the best choice for this demonstration timeframe. Milestones of the demonstration project are summarized below.

2007 HIGH-LEVEL SCHEDULE:

- Fabrication/qualification testing—May through late-August
- Internal GRC Concepts/Safety Review—July 17
- Johnson Space Center (JSC) Readiness Review—August 8
- “Dry Run” at JSC—August 13–17

- Final Safety & Readiness Review—August 21
- Desert RATS field trial—September 10–14

The principle objective was to demonstrate performance of an experimental lithium-ion battery employing advanced NASA electrolyte technology. This was done in conjunction with the D-RATS EVA spacesuits. Two different suit models were available for field trials: the I-Suit and the Mark III suit. The experimental battery powered the coolant circulation pump which forms a part of the D-RATS liquid air backpack (LAB or “Cryopac”). A commercial lithium-ion battery had been used to power the LAB in prior years. The demonstration battery was designed to be interchangeable with the commercial lithium-ion battery. Project objectives included:

- Demonstrate performance of a lithium-ion battery with ETDP-developed NASA electrolyte
- Support field trials with the Desert Research and Technology Studies (D-RATS) EVA LAB
- Complement field test data with laboratory testing under controlled-temperature conditions

A successful dry run was conducted at JSC, on the week of August 13, 2007. The dry run battery, containing NASA electrolyte, performed as expected in the LAB. Three field trials were successfully completed at Cinder Lake on September 10–12, 2007. EVA’s of up to 1-hr and 50-min were supported, with residual battery capacity sufficient for 30-min of additional run time.

Battery Design

Requirements

The experimental batteries were required to support the LAB power system for a planned run time of 2 hr. The power system was originally designed to be compatible with a commercial, lithium-ion camera battery (IDX, Endura E50S) which had a nominal capacity of 3.3 Ah. Key elements and power requirements for the D-RATS LAB are illustrated in Figure 1.

Power System for the MarkIII/I-suit D-RATS Cryopac

• Block Diagram

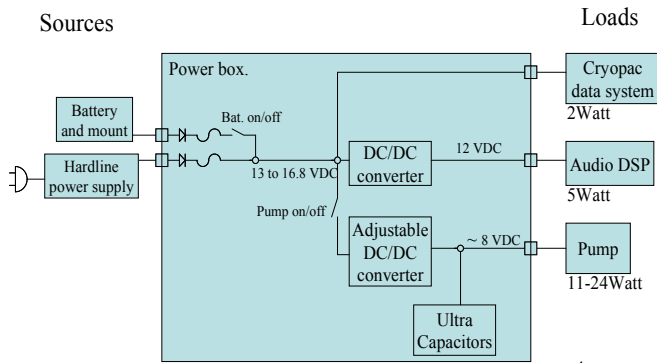

Figure 1.—LAB Power System Block Diagram.¹

The battery voltage window of 13 to 16.8 V was consistent with four Li-ion cells in series. Power levels and DC/DC converter efficiencies were used to estimate battery power requirements as shown in Table 1 (current is computed for a battery voltage of 12 V).

TABLE 1.—BATTERY POWER CALCULATIONS

	Net, W	Efficiency	Gross, W	Amps at 12 V
Data system	2	100%	2.0	0.17
Audio DSP	5	83%	6.0	0.50
Pump nominal	11	79%	13.9	1.16
total	18	Nominal	21.9	1.83
Data system	2	100%	2.0	0.17
Audio DSP	5	83%	6.0	0.50
Pump max	24	79%	30.4	2.53
total	31	Maximum	38.4	3.20

Sample Calculations

Battery capacity was selected to deliver the nominal power level of 22 W, for 2.5 hr—allowing a 20 percent margin for run time. This requirement translates to a total energy of 55 Wh. Assuming an average discharge potential of 3.6 V/cell, the target cell capacity is 3.8 Ah:

$$55 \text{ Wh} / (3.6 \text{ V/cell} \cdot 4 \text{ cell}) = 3.8 \text{ Ah}$$

The target capacity was 15 percent greater than the nominal capacity of the 3.3 Ah commercial battery. Average nominal current was computed to be 1.5 A (= 3.8 Ah/2.5 h). The maximum discharge current of 3.2 A (see Table 1) corresponded to approximately a 1C rate.



Figure 2.—Battery location on I-Suit LAB.

Physical Design

The experimental battery was designed to be physically interchangeable with the commercial battery. This precaution minimized risk: if any problems developed with an experimental battery, the commercial battery could be rapidly substituted in the field. Of course, battery fit within the LAB was a critical consideration in the physical design. Battery location on the LAB is illustrated in Figure 2.

The battery location was at the base of the LAB, close to the small of the suit-subject's back. Although there was no battery compartment *per se*, the space available for the battery was limited—particularly in thickness and width. The open compartment provided some latitude in battery length (the vertical dimension in Fig. 2). Dimensions of the experimental and commercial batteries are compared in Table 2.

TABLE 2.—BATTERY DIMENSIONS
[In millimeters.]

	IDX E50S	Target	Actual experimental battery
Width	86	92	76
Length	144	144	150
Thickness	34	48	39

A side-by-side comparison of the experimental battery and the IDX commercial battery appears in Figure 3.

¹Graphic courtesy of Craig Bernard, JSC



Figure 3.—Experimental and commercial batteries.

A commercially-available battery adapter plate (IDX part no. ANH2E) served as a base for the experimental batteries. This element guaranteed physical and electrical compatibility with the existing LAB battery interface. The IDX adapter was very well suited to the dimensions of the selected Li-ion cells and could be utilized with minimal modification. Details of the modified adapter and printed circuit board (PCB) appear in the Appendix. The finished batteries were 10 mm narrower than the commercial unit, with only a 5 mm increase in thickness.

The individual cell weighed 80 g. The dimensions (excluding tabs) were: thickness: 28.5 mm, width: 50 mm, length: 103 mm.

Cell Selection

Cells for the experimental battery were prepared by Quallion, LLC, Sylmar, California. Quallion was selected, based on open competitive solicitation. Details of the solicitation appear in the Appendix.

The Quallion, 4.5 Ah, prismatic pouch cell (part no. QL4500A) was developed for the U.S. Army Communications-Electronics Research, Development, and Engineering Center (CERDEC), under the “Ultra Safe High Energy Density Rechargeable Soldier Battery” program to address needs for soldier systems and equipment applications (Ref. 1). A key consideration in the selection of the Quallion cell was the availability of safety test data for the existing cell construction which was to be delivered. These cells met other specifications for fit and capacity.

Four-cell packs and individual cells were prepared using two different formulations of JPL electrolyte (see Appendix). These differed in solvent composition as shown in Table 3.

The control electrolyte was provided by Quallion. Quallion performed an analysis of the electrolytes received from JPL. These results compare to a Quallion specification <20 ppm for acid and water. The acid level in both electrolytes exceeded the Quallion specification of 20 ppm. This was not believed to represent a safety issue. The acid level in the JPL5 sample was two-times higher than observed in JPL2 (see Table 4).

TABLE 3.—EXPERIMENTAL ELECTROLYTE COMPOSITION

Designation	Composition, by volume
JPL 2	1.0M LiPF ₆ in EC+DEC+DMC+EMC (1:1:1:2)
JPL 5	1.0M LiPF ₆ in EC+EMC+MP (1:3:1)
Control	1.0M LiPF ₆ in EC+DEC+EMC

Note: see Appendix for explanation of abbreviations and number of cells

TABLE 4.—QUALLION ANALYSIS OF JPL ELECTROLYTES

Electrolyte	HF, ppm	Water, ppm	Conductivity, S/cm
JPL-2	41	5.92	8.90E-03
JPL-5	78	5.49	9.73E-03

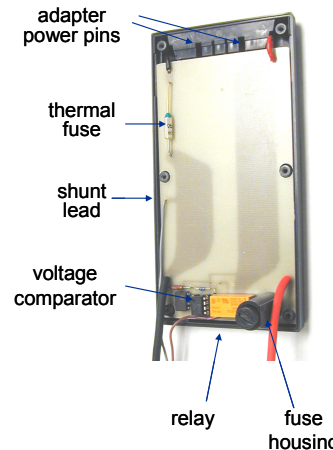

Figure 4.—Adapter plate with safety-system elements.

Internal Safety Features

Experimental batteries included built-in protection for over-current, over-discharge and over-temperature. These protection elements were mounted on a printed circuit board, housed within the battery adapter plate (see Fig. 4).

A replaceable, 4 A fuse protected the experimental batteries against over-current, and provided a means for manually disconnecting the cells from the power pins when the battery was not in use. Protection against over-temperature was provided by a nonreplaceable, 72 °C (maximum) thermal fuse. Tests of the thermal fuse showed an average opening temperature of 70 °C. A portion of the negative current trace on the printed circuit board served as a current measuring shunt. Shunt resistance was calibrated to be approximately 2.5 mΩ.

A simple voltage-monitoring circuit was developed to prevent over-discharge of the battery. The circuit used a miniature relay to interrupt current flow to the power output terminals if battery voltage was <12 V. Once open, the circuit had to be reset manually. When active, the safety circuit components drew ~20 mA. Circuit cutoff voltage was measured at the cell pack tabs. The target cutoff voltage was 12 V, based on a lower cutoff voltage limit of 3 V/cell. The 4.5 Ah Quallion cells could be safely discharged to 2.5 V/cell. A schematic of the circuit appears in the Appendix. Field trial

versions of the experimental battery included two LEDs to indicate the state-of-charge (SOC) of the battery. These indicators provided “at-a-glance” status checking during field trials and would signal the end of useful battery life. LEDs were connected to the power output terminals of the adapter plate through zener diodes. Both LEDs were illuminated when the battery voltage was greater than ~15 V, or ~70 percent SOC. The last LED extinguished at ~14 V or ~25 percent SOC. The LED display was always on, as long as the safety circuit was active (power connected to the output terminals).

The combined parasitic current drain of the safety circuit and display LEDs was less than 54 mA with battery at a full SOC. This corresponds to <2 percent of the battery capacity during the anticipated run time of 2 hr. The safety circuit and status LED electronics were all tested for functionality on an experimenters breadboard before being assembled into a printed circuit.

Data Acquisition

Two separate data loggers were selected for collecting battery data during field trials. A Pace Scientific, model XR440, logger recorded battery volts, current and ambient temperature (weight 158 g). An Omega, model OM-CP-TC4000, logger was used to log cell core temperature (weight 27 g). These loggers (see Fig. 5) used internal batteries.

Battery voltage was scaled to the 0 to 5 V range of the Pace logger by means of a voltage divider. The divide-by-four resistor pair (34/102 kΩ) was potted inside the head shell of the 9-pin data connector. This approach eliminated risk of external short-circuiting. The PACE logger included an 11 mV channel for monitoring current.

Electrical connections to the battery were facilitated by using a quick-connect, sub-D 9-pin connector mounted at the base of the battery. The data connectors included pins and sockets compatible with K-type thermocouples for accurate battery core temperature measurement. The 9-pin connector also provided leads to the individual cell terminals. These leads were used to monitor individual cell voltage and for cell balancing during charge.



Figure 5.—Data Loggers, shown with 1-in. grid.

Battery Assembly and Pre-Ship Testing

Four-cell packs of cells were delivered by Quallion with inter-cell, series connections and voltage monitoring leads in place. A K-type thermocouple was installed between the center cells to provide a measure of battery core temperature. The cell bundles were bound together with Kapton tape. Five of these pre-wired cell bundles were purchased: two with JPL5 electrolyte, two with JPL2 electrolyte and one with control electrolyte.

Each cell pack was tested as a free-standing unit before being assembled into a battery. Due to tight time constraints, battery testing was limited to two discharges at the maximum power condition of 38.4 W (intended to represent a worst case evaluation). An initial discharge was completed with the cell pack electrically connected to the safety circuit but not bonded to the PC board. Following a successful test of the cell-pack and PC board, the battery elements were built into a finished assembly and tested again to verify performance under the maximum power rate. In each case, the batteries were charged using the same equipment that would be used in the field. This testing verified that the battery would deliver expected capacity with satisfactory temperature rise under continuous operation at the maximum power requirement. The function of the over-discharge circuit and voltage-indication LEDs was also confirmed as a part of this testing.

The first two batteries, built with control and JPL5 electrolyte, provided experience with assembly techniques and materials. These batteries were also used during the August dry-run trials at JSC. The quantity of potting material—used to mechanically immobilize the cell pack inside the battery housing—was reduced in the field trial batteries, based on experience with the dry run samples. This produced a mass savings of approximately 20 g, and increased the specific energy to 130 Wh/kg. Width and length dimensions were dictated by the outside dimensions of the IDX adapter plate. Slight variability in battery thickness was due to variation in the hand-formed aluminum battery cover. Characteristics are summarized in Table 5.

TABLE 5.—EXPERIMENTAL BATTERY CHARACTERISTICS
[Testing Performed Under Maximum Power (38.4 W) Discharge Conditions at 23 °C Ambient Temperature.]

Battery	Control	JPL5-1	JPL5-2	JPL2-1	JPL2-2
Battery use	Dry run		Field trials		
Pack	6/25/07	6/25/0	7/10/0	7/10/0	7/10/0
Assembled	8/3/07	8/6/07	8/31/0	8/29/0	8/29/0
Mass, g	519.9	522.1	498.8	501.8	498.5
L, mm	150	150	150	150	150
W, mm	76	76	76	76	76
T, mm	38	38	39	37	37
Run Time, h	1.67	1.72	1.71	1.73	1.71
Capacity, Ah	4.50	4.61	4.57	4.63	4.59
Energy, Wh	64.36	66.38	65.83	66.68	65.91
Sp. Energy	124	127	132	133	132
Tmax, °C	32.1	35.1	34.1	37.0	35.3
Circuit cutoff	12.27	12.15	12.16	12.22	12.13

Battery assembly was completed in one day. First, the cell pack was completely discharged to minimize cell thickness and to enhance safety during assembly operations. After the individual cell voltages were recorded, the positive and negative power leads (16 AWG) were trimmed and soldered to the PC board/adapter assembly. The cell pack was then bonded to the surface of the PC-board, using a thermally-conductive, silicone adhesive (Chomerics T646). This material served as a heat transfer agent and gap filler between the cell-pack and the aluminum cover. Leads for individual cell balancing were connected to female 9-pin connector along with leads for the built-in thermocouple and current-measuring shunt. With the cell pack in place, the adapter flange was bonded to the adapter base with 3M Scotch-weld 2216 epoxy. Immediately after this step, the exposed face of the cell pack was coated with a layer of Chomerics T646 and the aluminum battery cover was pressed in place, fastened to the adapter with Scotchweld 2216 epoxy and screws. The electronics section of the PC board was partially filled with expanding urethane foam to encapsulate the lead wires and cell tabs and the aluminum end covers were fastened in place. Cell voltages were measured to confirm that connections had been properly made and the clamped assembly was allowed to cure overnight. The battery assembly is illustrated in cross-section in Figure 6.

Photographs illustrating battery assembly appear in Figures 7 to 10.

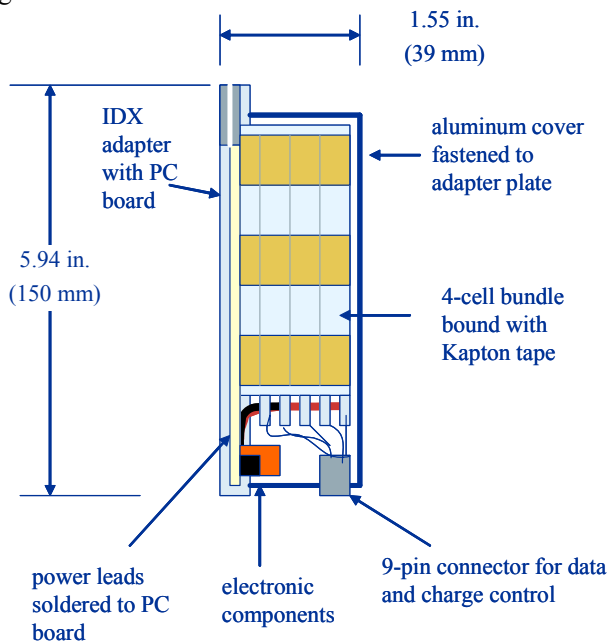

Figure 6.—Battery assembly cross-section.

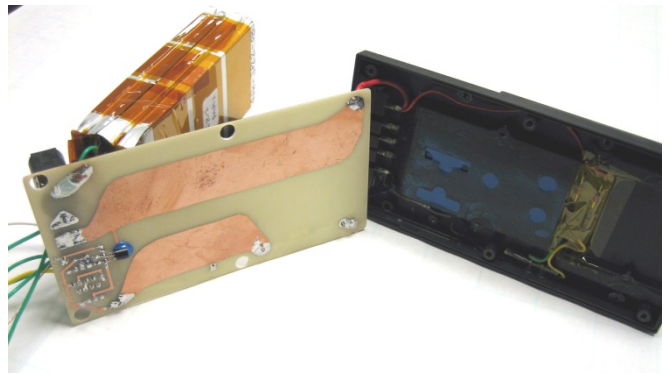

Figure 7.—Battery components soldered together.



Figure 8.—Heat transfer/gap filler applied to exposed face of cell-pack.

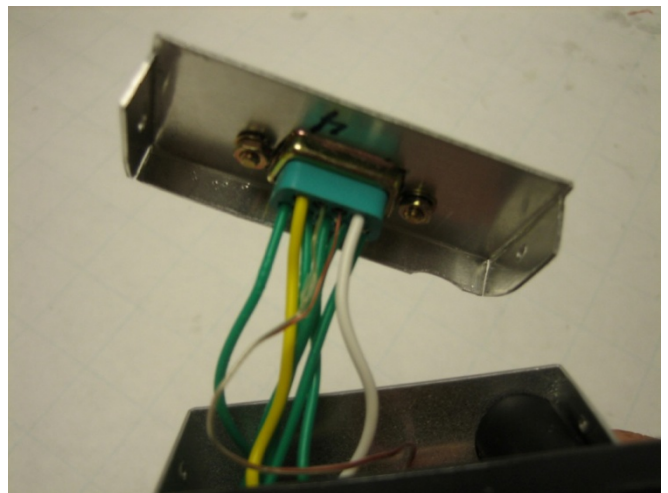

Figure 9.—9-pin data connector inside front cover.



Figure 10.—Finished experimental battery.



Voltage monitor Cell-balancing module

Figure 11.—Field-charging equipment.

Field Charging Equipment

Equipment for field-charging the experimental batteries was assembled in-house. Two components made up the charging control system. First, a voltage monitor used digital process controllers to display battery temperature and individual cell voltage. The voltage monitor contained a current interruption relay to halt charge if any cell exceeded the voltage limit of 4.25 V or if temperature exceeded 40 °C. An 8 Ω, 50 W power resistor was included to facilitate battery discharging operations. This function was useful for determining residual capacity after field trials and for discharging cells to a safe state-of-charge for shipping. Second, a cell balancing module automatically limited individual cell voltages to the desired control limit of 4.2 V. This unit was previously developed for lithium-ion cell testing and was available off-the-shelf (Ref. 2). These components are illustrated in Figure 11.

A 17 V/3 A dc power supply provided the appropriate constant-current/constant-voltage charge control. For safety, batteries were housed in a covered steel box during field charge/discharge operations.

Field Trials

Pre-Trials Safety Review Process Overview

As a NASA program with high visibility and media coverage, proposed D-RATS technology demonstrations are approved for field trials only after a stringent, formal safety review process is completed and reviewed by the JSC team's

Experiment Review Board (ERB). The safety review process is an especially critical step in the overall selection process for technologies such as this experimental battery performance demonstration, which is to be interfaced with and integrated into the power system for a human-worn I-suit backpack. In addition to the inherent safety of a proposed technology demonstration, the associated hardware must not interfere with suited test subject communications or other electronic equipment.

Principal Investigators were provided with specific responsibilities and guidance from the ERB with respect to required documentation for D-RATS hardware and test activities. At eight months prior to a proposed field trial at the Cinder Lake, Arizona site, a written, detailed technical overview of the proposed demonstration, including an identification of any associated safety concerns, was required. At four months prior, evidence was to be provided to the ERB that a successful level of laboratory-based testing had been achieved to allow for the dry-run activities at JSC. This evidence was to include a formal Hazard Analysis Report (HAR) for all hardware systems. At one month prior, a final “state-of-readiness” presentation to the ERB was required for the ERB to make a “go/no go” decision for participation in the field trial.

In response to both the ERB's and GRC's strong commitments to safety and D-RATS program compliance, initiatives were taken within the Electrochemistry Branch both to formalize the internal GRC review process and to complement and expand upon safety credentials for the proposed battery demonstration. In accord with GRC recommended practices, an internal review team was assembled, which embodied participants from the GRC Safety & Mission Assurance Directorate, the GRC Engineering and Technical Services Directorate and a lead battery engineer from JSC.

On July 17, 2007, a formal Concepts & Safety Review was held at GRC. At this review the technical concept, hardware safety attributes, laboratory testing results and proposed demonstration activities were presented, as was a formal GRC Hazard Analysis Report document, per GRC Systems Safety & Reliability Branch guidelines. Following the review, any technical questions or issues that remained were addressed, as were suggestion pertaining to the internal review process. Between this formal review and the dry-run activities at JSC, in-house laboratory performance testing of the batteries, protection circuitry, data monitoring hardware and the battery charging hardware continued. Also during this interval, a formal HAR Tracking Verification Log was established, and all items on such were closed-out. The HAR document served to identify potential hazards, causes, effects, risks, controls and verification procedures.

Following the dry-run activities at JSC, initiatives were taken within the Electrochemistry Branch to complement and expand upon safety credentials and documentation for the proposed battery demonstration. These initiatives included:

- (a) A document addressing the detailed field measures for battery inspection, handling and operational procedures was generated and approved by GRC technical management.
- (b) An informational handout covering the specific GRC battery hardware and associated safety and handling guidelines was prepared for distribution to D-RATS field trial personnel.
- (c) MSDS documents and a basic “lithium-ion battery safety” seminar presentation compiled by JSC battery personnel were assembled for distribution.
- (d) Quallion performed additional safety and abuse tests on the battery’s pouch cells that employed the NASA JPL experimental electrolyte.
- (e) A response was made to GRC Research & Technology Directorate management pertaining to “lessons learned” and suggestions for a formalized internal review process for future D-RATS demonstration initiatives.

On August 21, 2007, the final Desert RATS Safety & Readiness Review was held at GRC with Space Flight Systems Directorate management personnel in attendance. No outstanding technical, programmatic or safety issues or needed actions were identified, and written documentation of a successful assessment of the review was generated by GRC Advanced Flight Projects Office management for transmittal to the JSC ERB. The ERB made an affirmative decision for the battery technology demonstration at the Cinder Lake, Arizona field trial and for shipment of the demonstration hardware to the USGS facility in Flagstaff, Arizona.

August 2007 Dry-Run at JSC

The first batteries (control and JPL5-1) were used for dry-run activities at JSC during the week August 12, 2007. The control electrolyte battery was used for checkout of field instruments. All suit trials were performed with battery JPL5-1. Fit and function was verified and the dry run battery (containing NASA JPL5 electrolyte) performed as expected in three trials, including the I-suit as well as the Mark III suit. This was also the first opportunity to work with the data loggers. A day-by-day history follows.

Day 1: Fit and Function Test With I-Suit on Stand

Tests were conducted with the Cryopac attached to the upper torso of I-Suit (see Fig. 12) with cooling garment connected to pump. Battery functioned as-expected.

- Battery fit confirmed
- Pump switches normally to battery power
- 31-min run time
- Loggers on CAI pack, configured to transmit battery voltage data in real time



Figure 12.—Upper torso of I-Suit with Cryopac.

In this trial, the data loggers were mounted to a radio-transmitting, Communications, Avionics and Informatics unit (CAI pack) which was attached to the back of the LAB. The CAI pack successfully transmitted logger data in real time.

Day 2: I-Suit Field Trial

This was the first field trial with a suited subject. The objective of this test was to demonstrate battery operation with the LAB and to test the action of the over-discharge protection circuit while mounted on the LAB, in the presence of other transmitters. Suit-subjects were accompanied by spotters during all field trials, for assistance in maneuvering safely around field equipment (see Fig. 13).

Accomplishments:

- 37-min run time with suit subject in the field
- Continued discharge after EVA to test battery low-voltage shutoff circuit: circuit functioned normally
- Battery operated for a total run time of 3-hr
- Noise observed in voltage logger signal

The battery operated normally in this trial and over-discharge circuit activated at the desired 12 V cutoff. The voltage data logger transmitted data successfully, but the values showed considerable noise. Due to operator error, the temperature logger was not set up properly and did not record data.



Figure 13.—Spotter assists suit-subject, in I-Suit, to board the Scout rover vehicle.

Day 3: Mark III-Suit Field Trial Attempt

This trial was the first attempt with Mark III suit. Note that each suit has its own LAB. As in Day 2, the data loggers were connected to a laptop computer housed in the CAI pack, so that battery data could be transmitted in real time. The CAI pack is a separate module that is attached to the back of the LAB (see Fig. 14).

In this trial, the pump failed to operate on battery power when line power was disconnected. A commercial battery was substituted, per pre-established safety rules, and the EVA was completed without the experimental battery.

Checks of the experimental battery showed that the safety circuit had activated. Normal battery voltage was measured at the output terminals after the safety circuit was reset. The battery was observed to be quite cold to the touch, due to liquid air vapor impingement during the suit charging operation. A partial discharge test, performed with the field charging equipment, revealed steady current flow with the expected terminal voltage.

Inspection revealed no flaws in the experimental battery. It appeared that something triggered the shutdown safety circuit to open the relay, interrupting power to the output terminals. The battery was fully charged and stored overnight for the final day of testing.

Day 4: Mark III-Suit Indoor Trial

Inclement weather forced last-day operations indoors. This test was conducted with the Mark III suit, but without the CAI pack (see Fig. 15). Data loggers were mounted close to the battery compartment. Data was stored, as in previous runs, but not transmitted in real time.

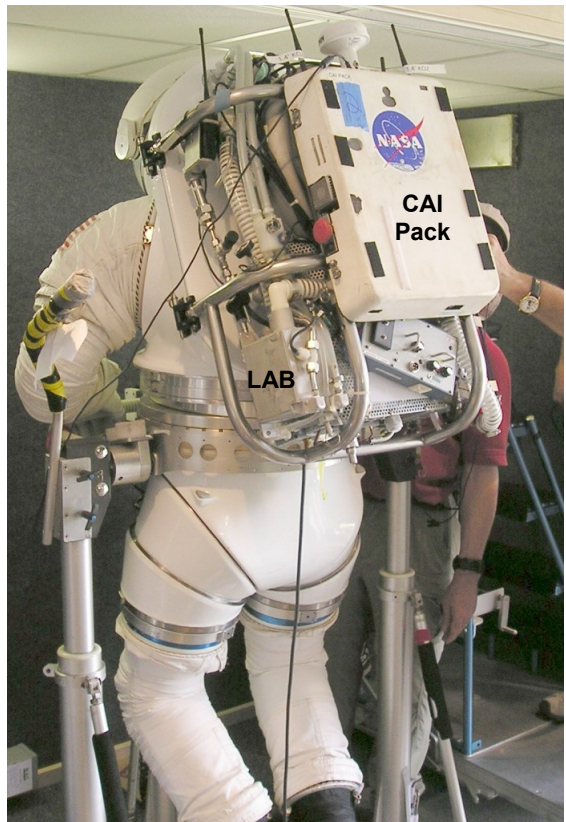

Figure 14.—LAB and CAI pack on Mark III suit.



Figure 15.—Mark III Suit on stand before day 4 dry run.

The battery performed normally with the Mark III suit in this test. A full discharge, after the EVA, showed that the safety circuit functioned normally, after powering the LAB for a total of 2.6 hr.

Both data loggers operated normally during the final day, but noise in the voltage and current signals continued to be excessive. The signal from the current shunt output (expected to be 4 mV) was impossible to interpret. Battery temperature increased normally at the end of discharge reaching approximately 30 °C. Data appears in Figure 16.

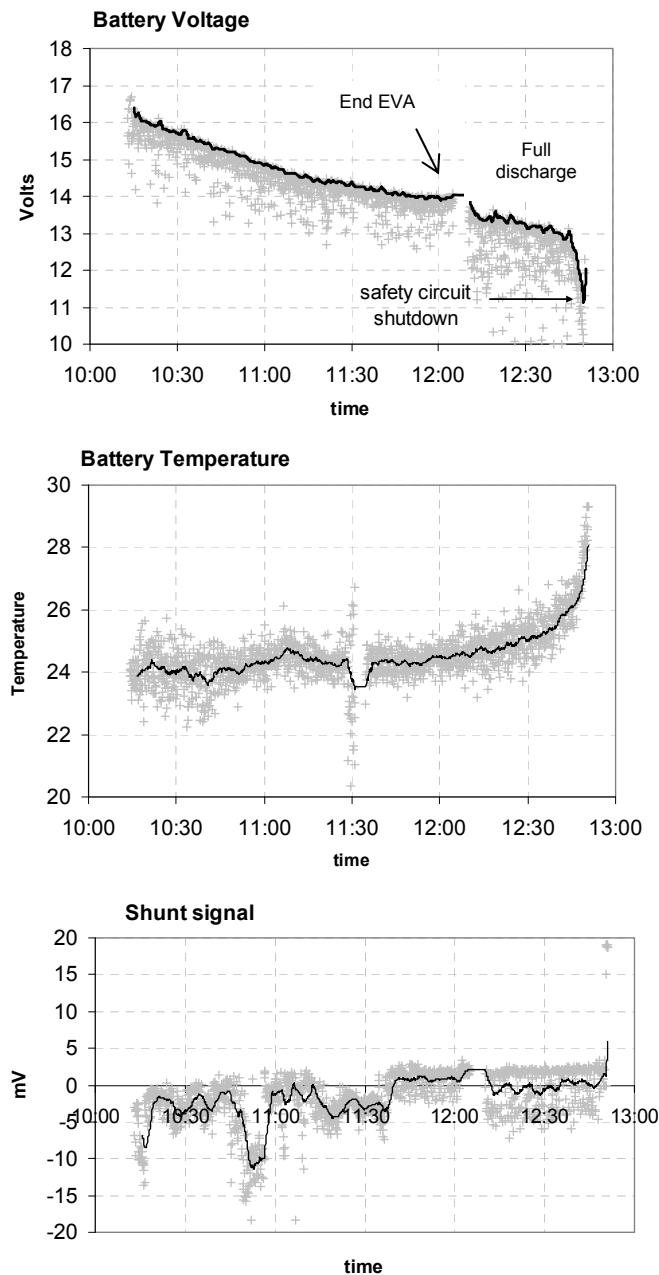

Figure 16.—Battery data from dry-run day 4 trial.

Observations and Actions Taken After the JSC Dry-Run

The same battery (JPL5-1) was used in all four days of testing. Three of the four trials were completely successful. Reasons for safety circuit activation on day 3 were not clear. The battery performed normally the following day.

In each trial, the fully-charged and activated battery was mounted on the LAB before liquid air was added. This process took approximately 20 min to complete. During that time, evaporated liquid air was vented close to the battery compartment, chilling the battery case so that it was very cold to the touch. Vibrations caused by venting air also produced a loud, intermittent trumpeting-sound. These vibrations would have been transmitted to the battery. Either of these factors may have caused a premature shutdown. Low temperature could create a dip in battery voltage at start up. Vibration may have caused the mechanical relay to open prematurely. Alternatively, electromagnetic interference may have caused the comparator in the safety circuit to malfunction. Further testing was necessary to pinpoint the cause of premature safety circuit activation. The problem occurred when the LAB pump was first switched over to battery power.

A voltage-indicating LED display was added to the final battery design in response to this shutdown incident. This feature provided instant verification of battery voltage at the power terminals. In the event of a battery shut down, the LEDs would extinguish and the spotters could quickly replace the experimental battery with a commercial battery.

Noise in the voltage logger data was peculiar to operation on the LAB. In the laboratory, data quality was quite good. In field trials a twisted pairs of wires were used for connection to the battery. New data cables were prepared with aluminum shielding to minimize EMI in the up-coming field trials. The loggers were also sheathed in aluminum.

The field charging equipment functioned as expected during the dry-run activity.

September 2007 Field Trials

Three successful field trials were completed between September 10 and September 12, 2007 at Cinder Lake in Flagstaff, Arizona. Battery charging operations were set up approximately 10 miles from the Cinder Lake site, at the United States Geological Survey facility.

Three, newly-prepared experimental batteries were available for these trials, designated as: JPL2-1, JPL2-2, and JPL5-2. Field trials lasted up to 1.9 hr in duration, consuming up to 3.7 Ah of capacity. The three successful trials were all conducted with the Mark III suit. A fourth trial, attempted with the I-suit on day 3, experienced the same premature safety circuit activation that was observed during the dry run activity. Details of the field trials are summarized below.

TABLE 6.—CINDER LAKE FIELD TRIAL RESULTS

Date	Battery Suit	EVA time, h	Final OCV, V	Delivered capacity, Ah	Average current, A
9/10/07	JPL2-1 Mark III	1.87	14.26	3.71	1.98
9/11/07	JPL5-2 Mark III	1.91	14.42	3.29	1.73
9/12/07	JPL2-1 I-Suit	0.38 on stand	16.42	n/a	n/a
9/12/07	JPL2-2 Mark III	1.65	14.52	2.81	1.70

Delivered capacity values in Table 6 are calculated from the actual capacity (measured in the laboratory) and the residual capacity that was measured after the field trial. Values for average current are computed from the stated EVA time and delivered capacity.

Day 1: Mark III Suit With JPL2-1 Battery

Data loggers with shielded cables were mounted in the LAB close to the battery compartment. The CAI pack was mounted to the LAB in this trial, but was not used for real time battery data transmission. Voltage indicating LEDs on the battery provided immediate indication of battery voltage to the spotters and made the option of real time transmission with the CAI pack unnecessary. The activated battery and data logger location are visible in Figure 17.

Ambient conditions were very mild during this week of field trials. Temperature was approximately 27 °C and the conditions were mostly sunny.

LAB transition to battery power on the suit stand was uneventful. The EVA mission plan consisted of driving the Scout rover vehicle to specific stations where different tasks would be performed by the suit subject. The 2-hr mission required one recharge of liquid air to the LAB. The experimental battery was required to operate for the entire mission. A view of the suit subject on Scout appears in Figure 18.

Shielding of the data cables and loggers significantly improved the quality of data that was collected, although some noise remained. Sample data appears in Figure 19.

An initial increase in ambient and battery temperatures (see Fig. 19) corresponds to egress from the air-conditioned trailer. Changes in incident sunlight on the battery compartment, as the rover was navigated around the field, probably produced fluctuations in temperature. Battery temperature increased gradually at the end of discharge, as expected. Internal battery temperature increased to approximately 30 °C at the end of the EVA, meeting expectations for heat exchange with the environment.

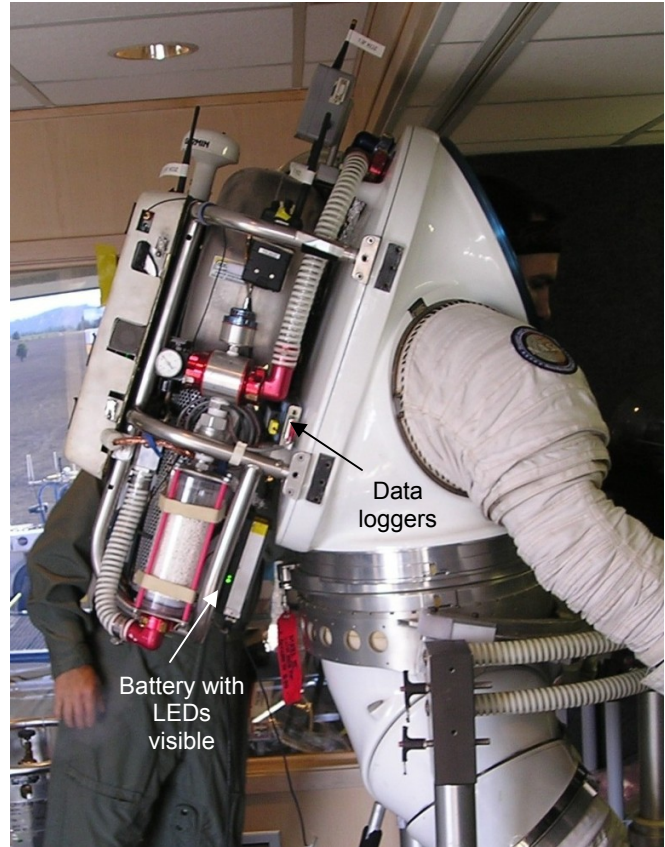

Figure 17.—Day 1 Field trial with Mark III Suit on stand before EVA.



Figure 18.—Day 1 Field trial, EVA with Scout Rover.

Day 2: Mark III Suit With JPL5-2 Battery

The day 2 trial was conducted using JPL2-2. Conditions and mission operations were essentially a repeat of day 1 and battery performance was as expected.

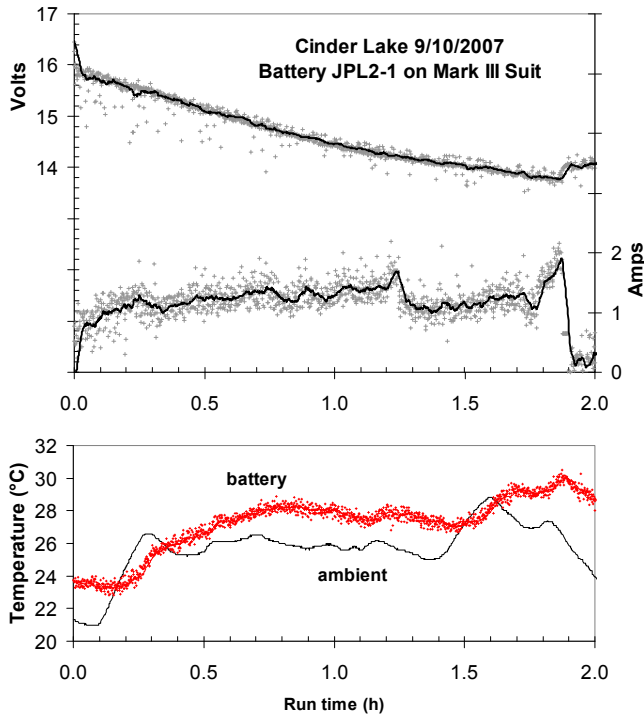

Figure 19.—Day 1 logger data.

Day 3: Mark III Suit With JPL2-1 Battery

On day 3, a third successful trial was completed using battery JPL5-2 on the Mark III suit.

Voltage and current history for the Mark III suit trials are superimposed in Figure 20.

The day 3 EVA was limited to 1.6 hr. All three trials displayed a slight reduction in battery current after approximately 1.3 hr. This event did not correlate with the liquid air recharging process. Suit operators did not make any adjustments to the pump speed setting. The reason for current change remains unexplained. Noise in the current signal continued to be considerable.

Day 3: I-Suit With JPL2-1 Battery

Based on the success of the two previous days, it was agreed that a parallel trial should be attempted with the I-Suit. Battery JPL2-1, which had performed flawlessly on day 1, was selected for the I-Suit trial.

The battery successfully supported the I-Suit LAB, while on the stand, for approximately 6-min. After 6-min, the operators heard the pump slow down, and noted that the battery LEDs were off. The liquid air charging operation was still in progress and it was believed that part of the soft I-Suit may have inadvertently pushed against the battery fuse button. This would temporarily disturb internal connections and activate the safety circuit.

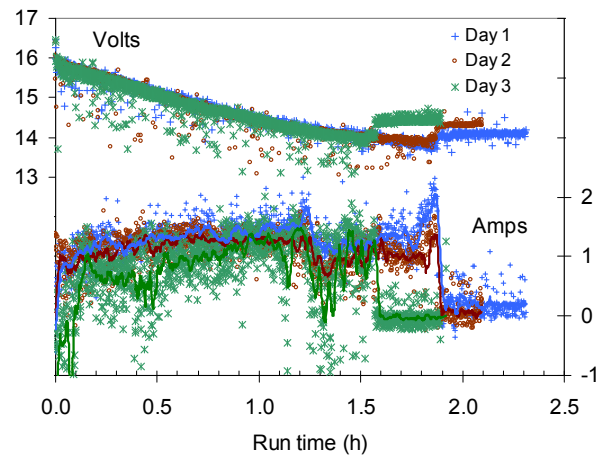

Figure 20.—Battery data with the Mark III Suit.

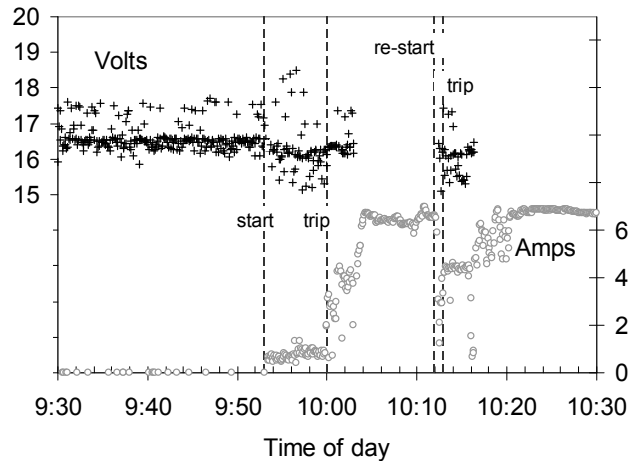

Figure 21.—Battery JPL2-1 voltage history on I-Suit.

A check of the battery showed normal terminal voltage after resetting the circuit. The LAB was operated with a commercial battery while the liquid air charging procedure was completed. A washer was taped around the exposed battery fuse button to guard it from accidental contact, the safety circuit was reset and the battery was replaced on the LAB. Within 1 min of operation on the stand, the battery shut off again. The I-Suit EVA was conducted with a commercial battery. Voltage logger history for the failed start up appears in Figure 21.

Ignoring the noise in Figure 21, battery voltage falls off slightly during the initial start up at 9:53. Current (calculated from the millivolt shunt signal) was steady at approximately 1 A until the circuit tripped. The safety circuit trips at 10:00 and voltage recovers gradually. Battery voltage is consistently >15 V, well above the 12 V shutoff limit. The data cable was disconnected from the battery after the safety circuit tripped, and the open logger channel drifted to an indicated current of 6 A.

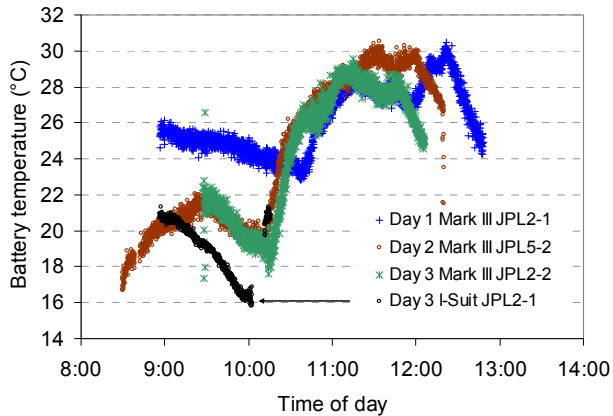

Figure 22.—Battery temperature history for all four field trials.

When the battery was removed from the LAB, it was found that the aluminum case was very cold to the touch. This is the same observation that was made in the failed dry run trial. Temperature data showed that battery temperature fell to 16 °C during the liquid air charging process. Battery temperature histories for all four field trials are compared in Figure 22.

Battery JPL2-1 proved to be only 8 °C cooler when operated on the Mark III suit on day 1. The successfully operated batteries on days 2 and 3 were also chilled during the liquid air charging process with battery temperatures only 3 °C warmer than in the failed trial. In fact, battery JPL2-1 warmed slightly during the interim checks and the addition of the fuse guard. During the second attempt to start the Lab on battery power, the core temperature had increased to 20 °C. Nonetheless, the safety circuit activated again.

Laboratory testing of the same batteries was completed after the field trials, at substantially lower temperatures. Results show that the minor chilling observed in the field would not trip the safety circuit (see following section). Some other factors must be responsible for the premature activation of the safety circuit.

Later, the I-Suit developed problems during the liquid air recharging process, while operating on the commercial battery. The EVA was terminated early. It is not believed that the LAB problems were related to battery shut down.

Laboratory Testing

Quallion Abuse Testing

Supplemental abuse testing was conducted at Quallion using retained cell samples. This included nail penetration and crush tests on fully-charged samples of cells with JPL electrolyte. Four cells of each electrolyte composition were evaluated. Results appear in Table 7.

The nail penetration test did not permanently short circuit any of the four cells tested. In contrast, the crush test produced a permanent short-circuit in the JPL2 electrolyte cells (OCV equal to zero). One of these cells (JPL2-29) caught fire. Before and after photographs appear in Figure 23.

Burning was limited to the region between the crush bar and the terminals. Presumably the crush fixture simply blocked fire from propagating to the other end of the cell. Companion cell JPL2-30 developed a hard internal short but did not burn. Cell JPL5-18 also developed an internal short circuit (OCV = 0.13 V) but did not burn. The author recognizes that these are small sample sizes. It is believed that cells of either electrolyte type could burn if short circuited in a fully charged condition.

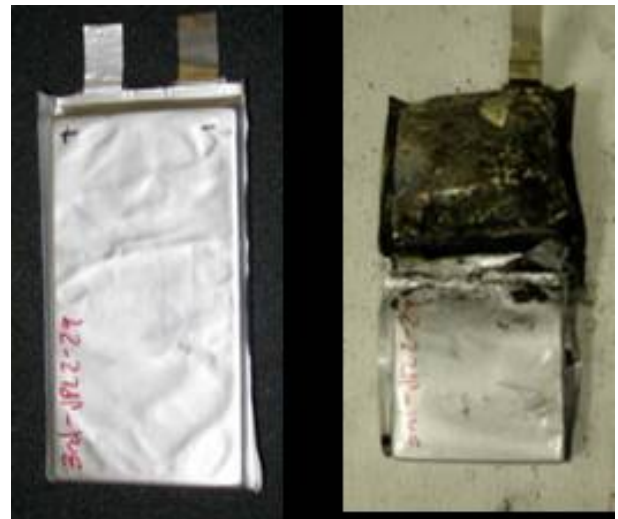

Figure 23.—Cell JPL2-29 before and after crush test.

TABLE 7.—QUALLION ABUSE TESTING

Cell ID	Initial Measurements					Pre-Test Measurements				Post-Test Measurements			
	IR (mohm)	OCV (V)	Weight (g)	Thickness (mm)	Capacity (Ah)	IR (mohm)	OCV (V)	Weight (g)	Thickness (mm)	Safety Test	IR (mohm)	OCV (V)	Weight (g)
JPL2-26	6.47	3.40	80.58	6.93	4.58	6.35	4.18	80.57	7.10	Nail	6.23	4.12	80.56
JPL2-28	6.66	3.40	80.04	6.81	4.57	6.56	4.18	80.04	7.01	Nail	6.35	4.09	80.04
JPL2-29	6.55	3.40	79.86	6.87	4.57	6.59	4.18	79.86	7.05	Crush	N/A	0.00	exploded
JPL2-30	6.75	3.40	79.35	6.93	4.55	6.74	4.18	79.35	7.08	Crush	31.20	0.00	78.42
JPL5-01	6.05	3.39	79.43	6.84	4.59	6.00	4.18	79.43	7.04	Nail	5.41	4.01	79.44
JPL5-12	6.07	3.39	79.29	6.82	4.60	6.03	4.18	79.29	7.09	Nail	5.59	4.03	79.28
JPL5-18	6.26	3.40	79.46	6.86	4.57	5.90	4.18	79.46	7.02	Crush	61.00	0.17	77.76
JPL5-16	6.13	3.40	79.50	6.86	4.55	5.99	4.18	79.50	7.10	Crush	15.21	4.03	78.84

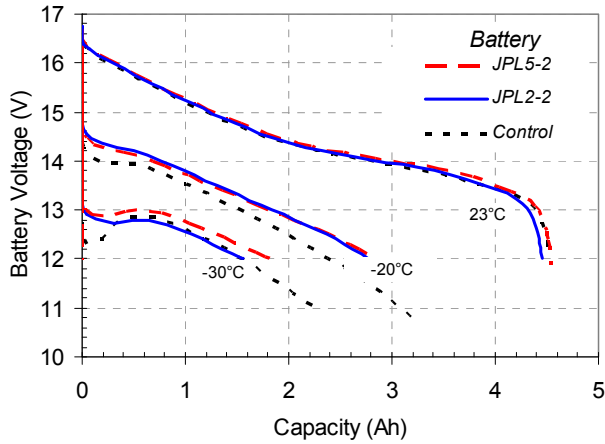

Figure 24.—Experimental batteries at 26 W constant power discharge.

Laboratory Testing of Batteries at GRC

Following the field trials, experimental batteries and cells were evaluated in the laboratory for low-temperature performance. Charge/discharge testing was conducted using an Arbin Instruments BT2000 battery tester. Cells and batteries were enclosed in a temperature controlled chamber during evaluation (Tenney Model TUJR). Test temperature was confirmed using a calibrated digital thermometer (Omega Model 52). Actual test temperatures were controlled to within ± 2 °C.

All charging was conducted at 20 °C, using field-trial procedures (C/2 constant current charge to 4.2 V, followed by a taper charge to C/20). A 26 W, constant power discharge was selected for battery performance testing. This was 18 percent greater than the nominal power level and produced an average discharge rate of approximately C/2.5. Results for selected batteries appear in Figure 24.

Capacity retention at low temperature is similar for all three electrolytes. Battery JPL5-2 showed a slight improvement over the control and JPL-2 battery, retaining 60 percent of the room temperature capacity at -30 °C.

The batteries were not modified in any way for low-temperature testing. The electronics and adapter connections were just the same as in the field trials. Even at -30 °C, the battery voltage did not fall below the 12 V safety circuit cutoff-level. This supports the argument that chilling of the batteries was not responsible for premature shutdown with the suit on the stand.

Note that the over-discharge circuit, in batteries with JPL electrolyte, automatically terminated discharge at 12 V. The Control battery had its circuit disabled and could be discharged below 12 V.

Cell-to-cell voltage balance was monitored during these trials. The range of cell voltage (highest minus lowest value) varied with progress of discharge and temperature. Results appear in Figure 25.

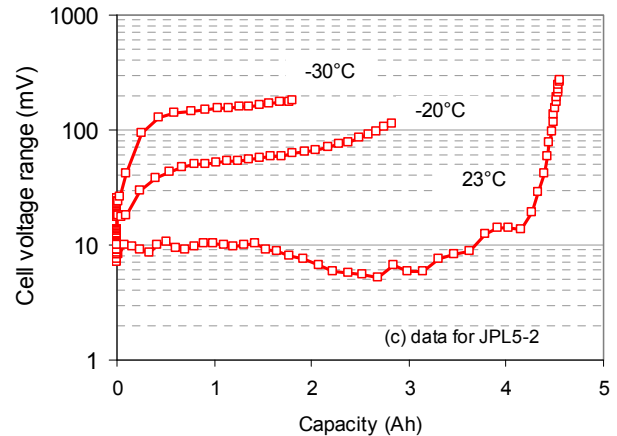
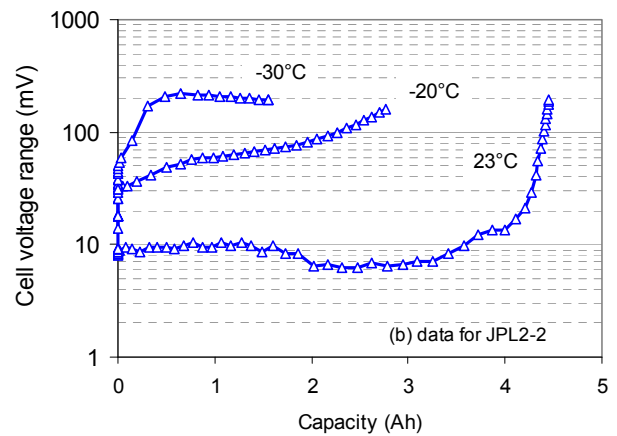
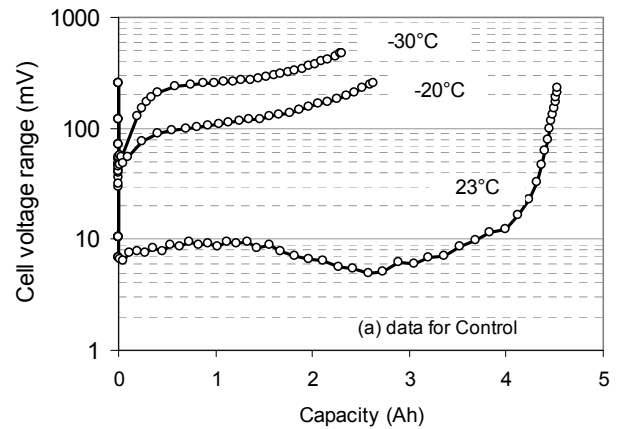

Figure 25.—Cell voltage balance in batteries at 26 W.

Cell voltage balance was better than 0.3 V in these trials.

Samples of commercial, IDX Endura batteries were also evaluated. Note that the model Endura E50S battery, which had been used in previous years, was discontinued by IDX. A replacement battery (Model E7S), with capacity similar to the NASA experimental batteries, was available in 2007.

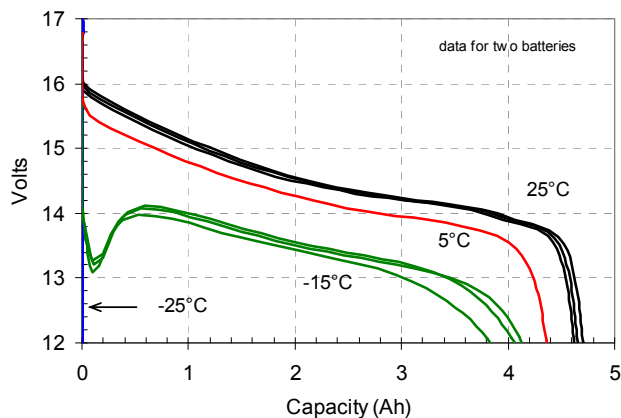

Figure 26.—Endura Model E7S battery performance at 26 W.

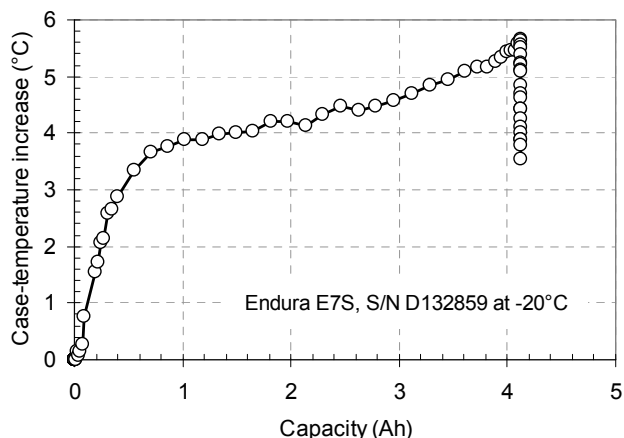

Figure 27.—Case-temperature increase of Endura battery during 26 W discharge at $-15\text{ }^{\circ}\text{C}$.

Two Model E7S (nominal capacity: 4.8 Ah) batteries were evaluated using the 26 W moderate-power profile. An IDX Model VL-2 charger was made available by NASA JSC to facilitate charging of the Endura batteries. Battery charging was performed at room temperature, within 24 hr of discharge testing. Discharge capacity results appear in Figure 26.

The commercial battery, which was not designed to operate at low temperatures, polarized to 12 V immediately at $-25\text{ }^{\circ}\text{C}$ and did not develop any measurable capacity. The Endura battery also showed substantial initial polarization at $-15\text{ }^{\circ}\text{C}$, but recovered due to self heating and retained 87 percent of room temperature capacity. Case temperature increased by $4\text{ }^{\circ}\text{C}$ during the first 1 Ah of discharge (see Fig. 27).

Auxiliary Testing

Electrical components were evaluated as a part of the experimental battery development. The over-current protection fuse was sized to assure delivery of the maximum expected current to the LAB, with consideration for the maximum current rating of the Quallion pouch cells. Based on

Table 1, the maximum power corresponded to 3.2 A at 12 V. The maximum current rating of the Quallion pouch cells was 2C, equivalent to 8 amps (Ref. 3). In testing, the 4 A, fast-acting, instrument fuse that was selected for the experimental batteries demonstrated a maximum current capability of 7 A.

Fuse samples were tested at room temperature, using the same model of fuse-holder that was selected for the experimental batteries. Current was ramped at a rate of 0.6 A/min. until the fuse opened. Results for two samples appear in Table 8.

TABLE 8.—OVER-CURRENT FUSE TESTING

	Current at fuse activation, A	Resistance, mΩ
Run1	6.95	98.4
Run2	7.11	97.5
Avg.	7.03	97.98

The $70\text{ }^{\circ}\text{C}$ thermal fuse, selected for over-current protection was also evaluated in the laboratory. Samples were soldered to a test board, using heat-sinking techniques planned for battery assembly. Samples were equilibrated at $23\text{ }^{\circ}\text{C}$, then heated at $1\text{ }^{\circ}\text{C}/\text{min}$. while carrying the maximum LAB current of 3.2 A. Results for three samples were very repeatable and consistent with the $70\text{ }^{\circ}\text{C}$ nominal rating. Results appear in Table 9.

TABLE 9.—THERMAL FUSE TESTING

	Temperature at current interruption, $^{\circ}\text{C}$	Resistance, mΩ
Run1	70.73	1.79
Run2	69.63	1.69
Run3	69.61	1.60
Avg.	69.99	1.69

Laboratory Testing of Cells at GRC

In addition to the 4-cell packs, individual cells were prepared by Quallion for laboratory evaluations.

Two cells of each electrolyte type were tested at a constant-power level of 6.5 W - equivalent to the 26 W levels selected for battery testing. Cell capacity results appear in Figure 28.

None of the cells tested produced any meaningful capacity at temperatures less than $-35\text{ }^{\circ}\text{C}$. Assuming a 2.5 V cutoff, cells with control and JPL2 electrolyte retained 50 percent of their room temperature capacity at $-30\text{ }^{\circ}\text{C}$. The JPL5 electrolyte preserved 60 percent of room temperature capacity at $-30\text{ }^{\circ}\text{C}$. Companion plots for retained energy plots appear in Figure 29.

Energy plots capture the combined effects of capacity loss and polarization, providing a more complete measure of low temperature performance. JPL5 electrolyte cells retained approximately 48 percent of the room temperature energy at $-30\text{ }^{\circ}\text{C}$. This represented a 20 percent improvement relative to the control and JPL2 cells, which retained 40 percent of the room temperature energy at $-30\text{ }^{\circ}\text{C}$.

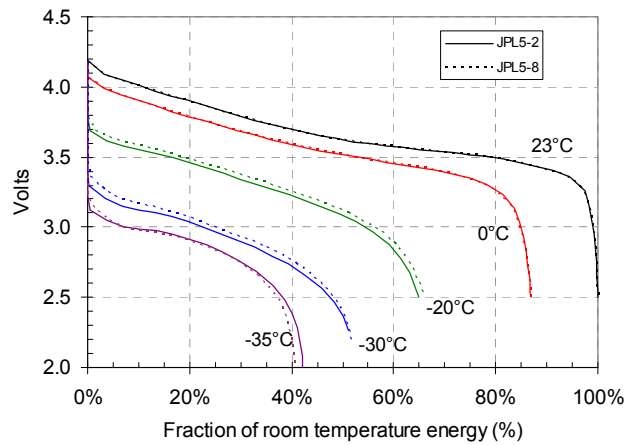
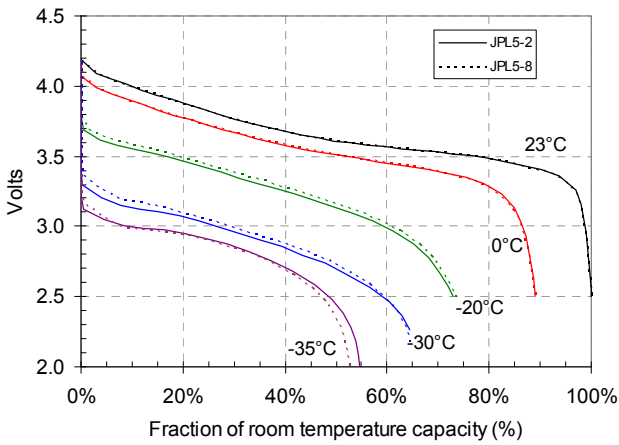
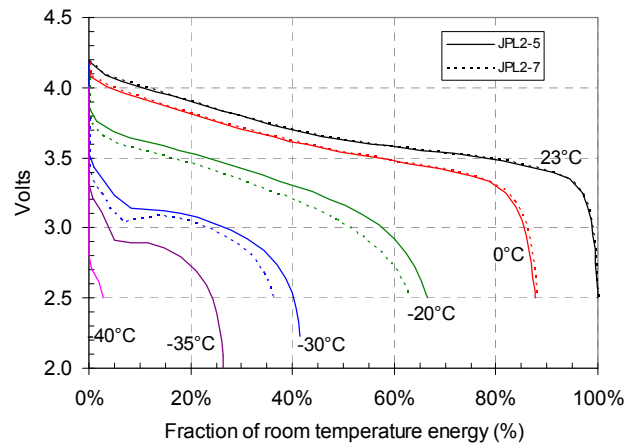
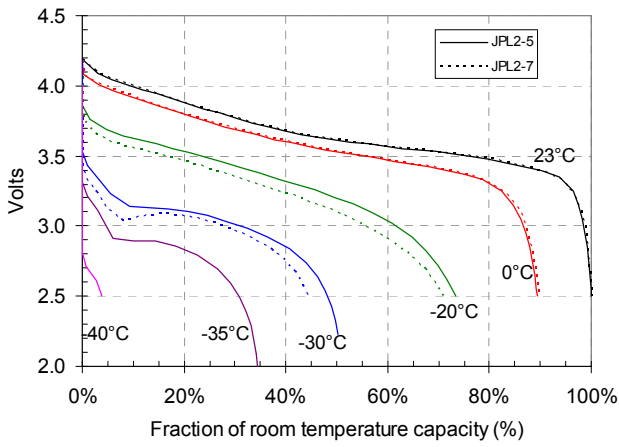
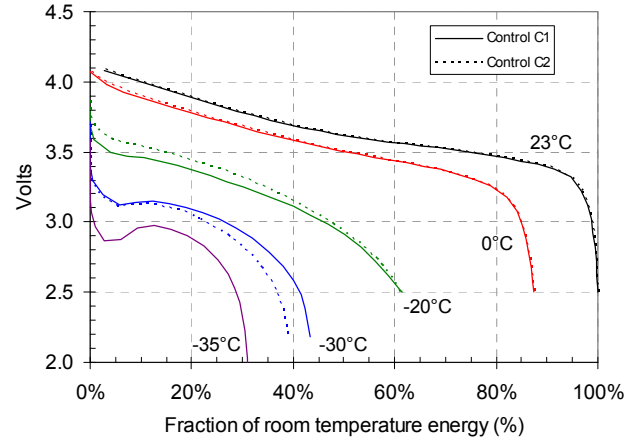
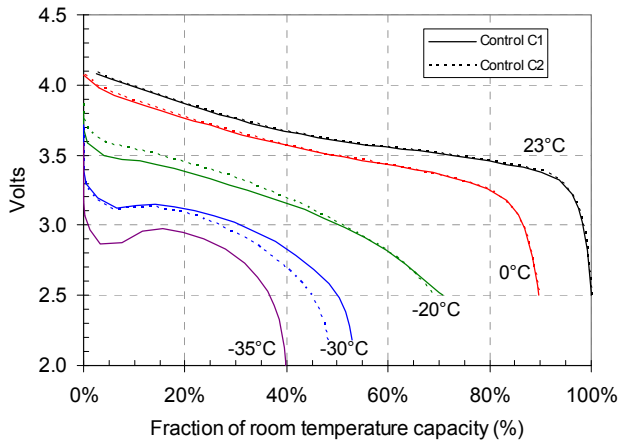

Figure 28.—Capacity retention at reduced temperature.

Figure 29.—Energy retention at reduced temperature.

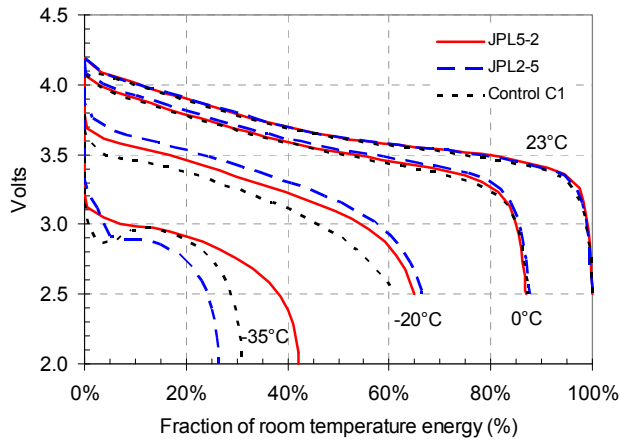

Figure 30.—Electrolyte energy-retention comparison.

At temperatures less than $-20\text{ }^{\circ}\text{C}$, the Control and JPL2 cells exhibit a noticeable “dip” in the polarization curve. This corresponds to self-heating of the cell which reduces polarization. Energy retention results for the three electrolyte types are compared in Figure 30.

Conclusions

This 5-month demonstration effort produced additional data for the performance of NASA-developed electrolytes in an experimental pouch cell construction. Experimental batteries performed successfully in three D-RATS field trials, powering the LAB in simulated EVAs approaching 2 hr. A simple circuit that was designed to prevent over-discharge of the batteries, activated prematurely during preparation of the LAB in two trials. The weight of evidence appears to point to an EMI issue or interaction with the LAB electrical system during the transition from line power to battery power. No incidents ever occurred during operation in the field.

All three of the electrolytes exhibited good retention of capacity at low temperature. In general, electrolyte JPL5 produced less polarization in single cell testing, achieving 40 percent of the room temperature capacity at $-35\text{ }^{\circ}\text{C}$. No significant capacity was delivered at $-40\text{ }^{\circ}\text{C}$ under the moderate power level selected for these evaluations.

All of the experimental batteries outperformed the Endura battery at very low temperatures.

The experimental battery was designed to maximize heat exchange - in order to minimize temperature rise during field trials in Houston and Arizona. In contrast, the Endura battery houses cylindrical, 18650-size cells in a heavy plastic case which tends to restrict heat exchange with the environment. The enhanced heat exchange that was designed into the experimental batteries probably limited low-temperature performance.

Inexpensive data loggers selected for field trials produced considerable noise. In particular, the battery current signal was quite weak and showed interaction with the LAB power system while on the stand. Any future attempts will require some additional development of the data acquisition elements. An amplified current signal would be preferable.

References

1. Contract No. W15P7T-05-C-P212.
2. Reid, *et al.*, “Lithium-Ion Cell Charge Control Unit,” 2004 NASA Aerospace Battery Workshop, November 16–18, 2004.
3. Lithium Ion Battery Packs for Portable Life Support System Simulator Proposal prepared for: NASA/Glenn Research Center Solicitation No. NNC07194975Q.

Appendix

Abbreviations

EC	Ethylene Carbonate
EMC	Ethyl Methyl Carbonate
DMC	Dimethyl Carbonate
DEC	Diethyl Carbonate
MP	Methyl Propionate
HF	Hydrofluoric acid

Cell and Battery Inventory

Electrolyte type	Single cells	4-cell packs
Control	4	1
JPL-2	7	2
JPL-5	7	2

Total of 38 cells

Cell Inspection After Storage

Cells were stored at room temperature at a 50 percent state-of-charge condition on December, 2008. OCV was measured again after 14-months of storage. Results for cells are summarized below.

cell	12/9/2008	2/9/2010	loss (mV)	Observations and remarks
Q1	3.60	3.60	-4	Normal appearance
Q2	3.62	3.63	-5	Normal appearance
Q3	3.66	3.66	-4	Normal appearance
Q65R	3.66	3.66	-1	Slight wrinkling of pouch material
JPL2_09	3.68	3.68	0	Normal appearance
JPL2_10	3.67	3.67	-1	Normal appearance
JPL2_11	3.67	3.67	-2	Slight wrinkling of pouch material
JPL2_12	3.68	3.68	1	Slight wrinkling of pouch material
JPL2_13	3.68	3.68	1	Normal appearance
JPL2_5	3.61	3.62	-5	Slight gassing
JPL2_7	3.62	3.63	-8	Slight gassing
JPL5_19	3.64	3.62	16	Slight gassing
JPL5_2	3.57	3.52	46	Moderate gassing
JPL5_3	3.88	3.80	78	Evidence of extreme gassing
JPL5_7	3.64	3.63	13	Moderate gassing (cell was dropped during initial inspection)
JPL5_8	3.55	3.49	58	Moderate gassing
JPL5_9	3.64	3.62	16	Slight gassing
JPL5_10	N/A			Cell was disassembled for destructive physical analysis

Cells with JPL-5 electrolyte showed substantially greater gassing and voltage loss after storage. This is likely linked to the greater HF content that was present in the JPL-5 electrolyte (see Table 4). JPL-5 batteries also showed obvious bulge after storage. Photographs of the cells and batteries appear below.

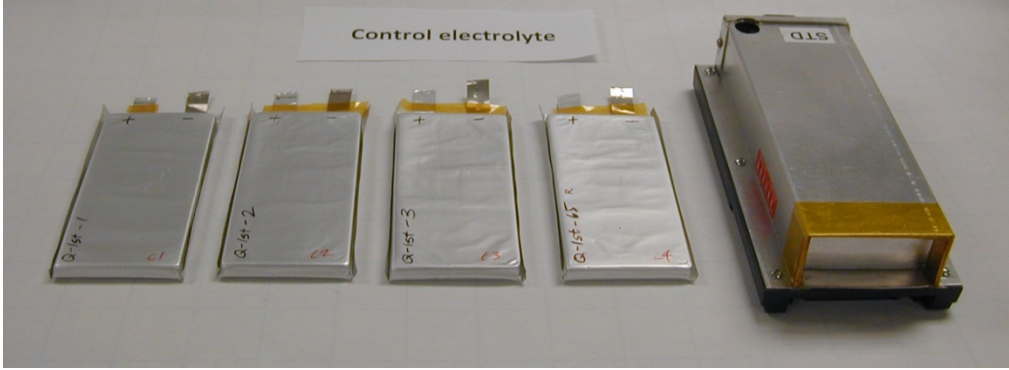

Control electrolyte



JPL-2 electrolyte



JPL-5 electrolyte

Lithium-Battery Solicitation

Overview

NASA Glenn Research Center is interested in purchasing a number of small lithium-ion battery packs configured to power a portable life support system (PLSS) simulator in a demonstration scheduled for the fall of 2007. The objective of this effort is to demonstrate improved battery performance using an experimental electrolyte, which has been developed by NASA for next-generation lithium-ion batteries. NASA shall provide a sufficient quantity of the experimental electrolyte for substitution in the demonstration cells/batteries. A small number of control cells, with the vendors "standard" electrolyte, will also be required for laboratory test comparisons. A vendor having experience with Li-ion battery manufacturing methods shall assemble the demonstration batteries.

The PLSS will be operated in sessions at the NASA D-RATS field trials at Meteor Crater, Arizona in September 2007. In previous trials, a commercial lithium-ion camera battery (IDX Endura E-50S) has been used to power this device. A person in the field wears the D-RATS PLSS during this demonstration. Availability of vendor's safety qualification data for similar cells and/or batteries is essential for establishing safety guidelines for demonstration. Submission of existing data for cell-level abuse-tolerance represents a best value for selection.

The vendor shall deliver pre-wired battery assemblies with power leads and provisions for monitoring individual cell voltages. NASA plans to complete the integration of the battery package into a housing that is compatible with PLSS. Consultations with the battery vendor will be required to assure that integration in the PLSS meets safety requirements and vendor's specifications. Battery assemblies with internal safety features will be considered a best value for selection.

Field demonstrations shall consist of powering the PLSS demonstrator. Knowledgeable personnel will conduct all battery charging operations in a laboratory-environment. It is planned that individual cell voltage and temperature will be monitored closely during charging operations. Cell balancing will be performed manually (if necessary) by discharging cells through the voltage sensing leads. An automatic battery charger, which facilitates the charging process, is desirable but not essential.

What is Required

Qty.	Description	Delivery required on or before
	Demonstration of prior experience with proposed product	Delivered with proposal
	Conceptual drawing of proposed battery assembly	Delivered with proposal
	Safety qualification data package for standard cell	Delivered with proposal
10	Individual cells with vendor's "standard" electrolyte	May 14, 2007
8	Individual cells with NASA electrolyte	June 4, 2007
1	Battery with vendor's "standard" electrolyte	May 14, 2007
4	Batteries with NASA electrolyte	June 4, 2007
	Data package for all cell/batteries delivered.	Accompanies delivered article

Assurance of delivery date is essential. Early delivery will be considered a best value for selection.

Options for Additional Deliverables

If capacity exists to deliver additional cells/batteries, within the schedule timeframe, please propose this as an option in addition to the required deliverables.

An automated battery charger with built-in cell monitoring could also be an option to the proposal.

Best-Value Selection Criteria

- Early delivery of batteries and cells
- Internal safety features
- Abuse tolerance data for similar cell designs

Safety Considerations

1. Prior data for standard electrolyte cells under abuse conditions is essential for planning and evaluating safety measures for field trials.
2. If the proposed battery cells are of an existing production design, a data package of abuse tests and failure modes shall be made available.
3. If the proposed battery cells are of a unique size or shape, then data for cells of similar construction and identical electrode/electrolyte type may be substituted.
4. At a minimum, batteries shall be sufficiently robust to tolerate a five foot drop onto a concrete floor when fully charged, without a safety incident.

Battery Specifications (Based on Vendor's Standard Electrolyte)

1. Discharge capacity: greater than or equal to 4 Ah at a C/2 rate at room temperature
2. Discharge voltage window: 12 to 17 V
3. Maximum, continuous discharge current: 4 A
4. Maximum battery external dimensions (inches): 4.875×3.375×1.375
5. Operating temperature range (discharge):² -40 to 60 °C
6. Battery specific energy (target) >180 Wh/kg
7. Seal integrity: no detectable electrolyte leakage for a period of 1 year.
8. Cell matching within batteries shall be adequate to complete at least 10 room-temperature charge/discharge cycles with cell voltage balance maintained at 2 percent or better.
9. Solder-able power leads: 12 in. length, sized to for maximum current/voltage (8 A/17 V).
10. Solder-able leads for monitoring individual cell voltage 12 in. length.

Power and monitoring leads shall be pre-attached to the appropriate cell terminals when shipped.

Physical Markings

Each cell and battery back shall carry external markings to uniquely identify components. As a minimum, the following shall be included:

- Name or part number
- Serial number
- Typical voltage range
- Type of Chemistry

Data Package

1. Disclosure of cell makeup including separator type, electrolyte composition, electrode composition.
2. Recommended charging procedures for standard electrolyte.
3. Individual cell dimensions and mass.
4. Cell formation data for irreversible capacity loss.
5. Cell capacity, energy data for first three cycles at 25 °C.
6. Battery capacity, energy data for first three cycles at 25 °C.

Cell Qualification Package

Existing abuse-test data for similar cells.

²Laboratory testing of the cells shall be conducted in this temperature range. Cell components shall be capable of exposure to these limits without physical breakdown.

Safety Circuit

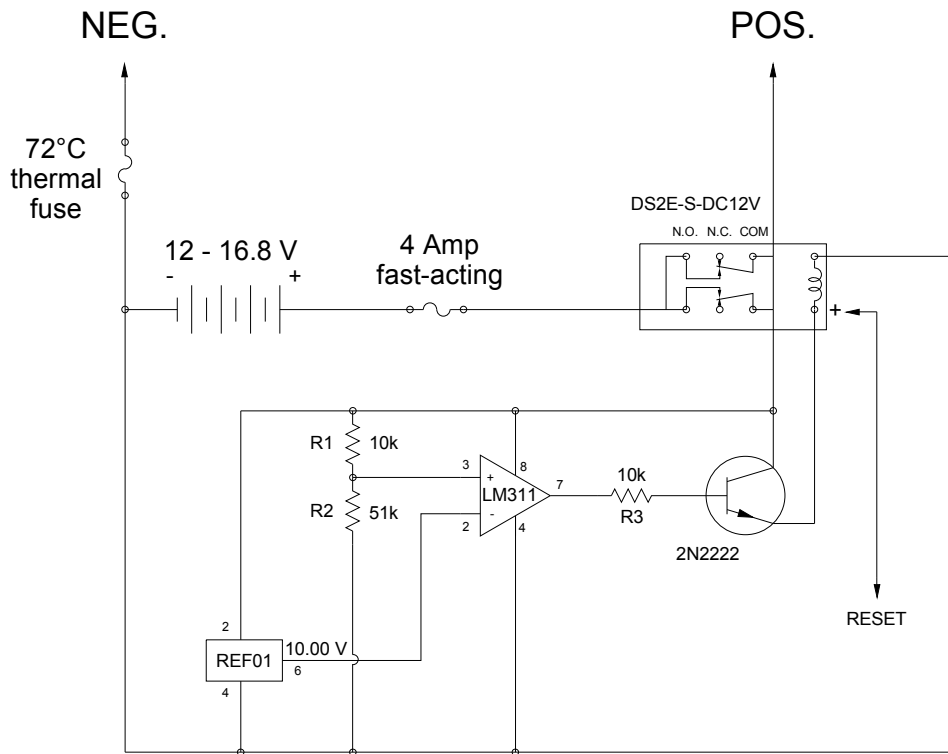

Voltage divider

R1	10
R2	51.1
	61.1

	planned	actual	scaling factor	error
			0.83633	
			0.83816	0.22%

Breadboard Results

Vbatt	Ref	Input	Coil	relay	mA
16.8	10	14.05	11.81	on	21
15.0	10	12.53	10.29	on	18.8
14.0	10	11.71	9.45	on	
13.0	10	10.87	8.62	on	16
12.5	10	10.43	8.19	on	
12.1	10	10.11	7.88	on	
12.0	10	10.02	7.77	on	
11.9	10	9.94	0	off	
11.4	10		0	off	
11.2	9.8	9.36	0	off	

Shut-off Cases

	normal	avg	95% DoD	5% DoD
cell 1	3	3.6	3.33	4
cell 2	3	3.6	3.33	4
cell 3	3	3.6	3.33	4
cell 4	3	1.2	2.01	0
total	12	12	12	12

Self-discharge time

4.5 Ah
 21 mA
 214 hrs
 8.9 days

Breadboard Results

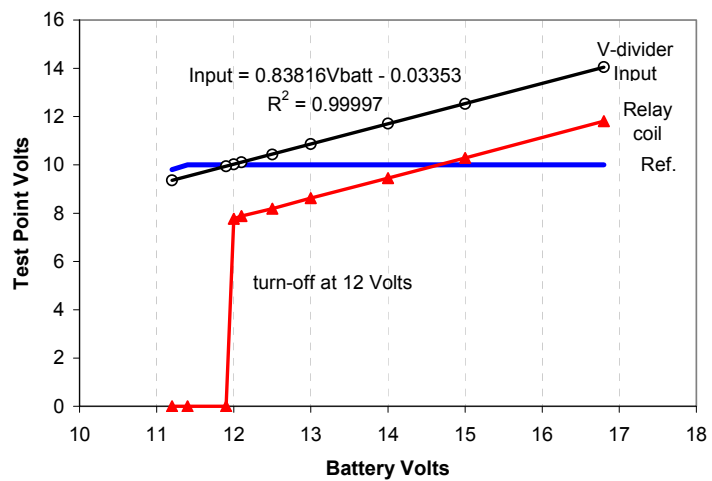

Printed Circuit Board (Dimensions in Inches)

PC Board rev. 4

TOP VIEW

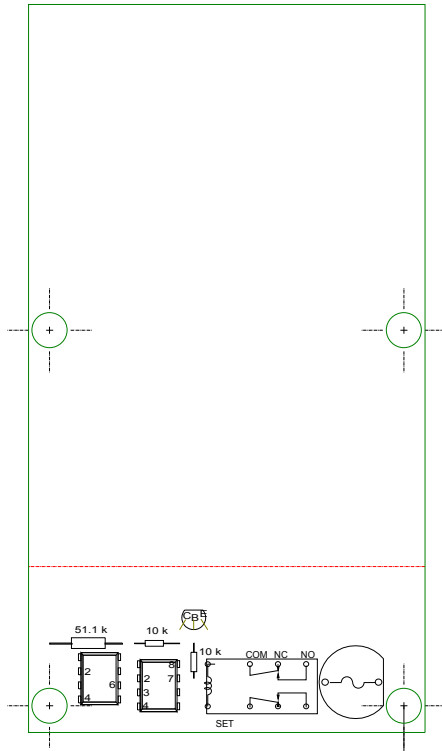

BOTTOM VIEW (copper side)

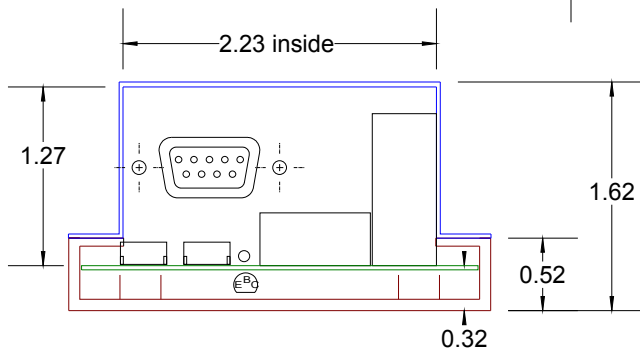
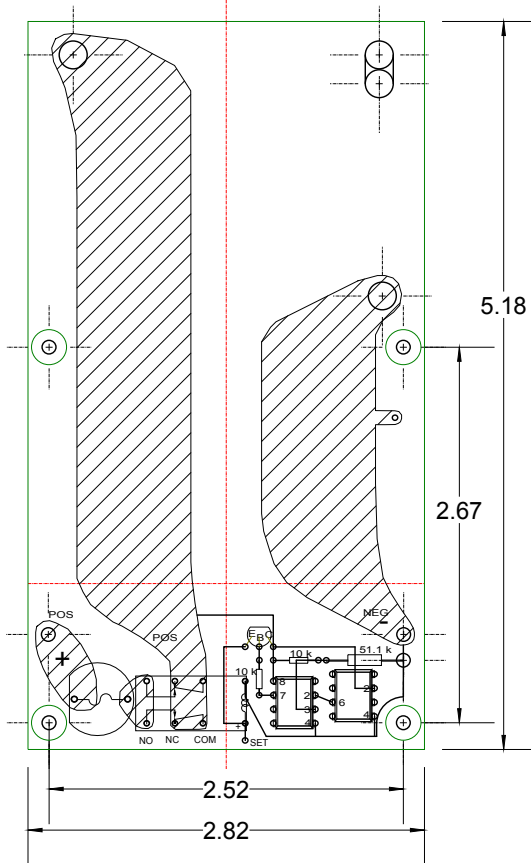

REPORT DOCUMENTATION PAGE			Form Approved OMB No. 0704-0188		
<p>The public reporting burden for this collection of information is estimated to average 1 hour per response, including the time for reviewing instructions, searching existing data sources, gathering and maintaining the data needed, and completing and reviewing the collection of information. Send comments regarding this burden estimate or any other aspect of this collection of information, including suggestions for reducing this burden, to Department of Defense, Washington Headquarters Services, Directorate for Information Operations and Reports (0704-0188), 1215 Jefferson Davis Highway, Suite 1204, Arlington, VA 22202-4302. Respondents should be aware that notwithstanding any other provision of law, no person shall be subject to any penalty for failing to comply with a collection of information if it does not display a currently valid OMB control number.</p> <p>PLEASE DO NOT RETURN YOUR FORM TO THE ABOVE ADDRESS.</p>					
1. REPORT DATE (DD-MM-YYYY) 01-11-2010		2. REPORT TYPE Technical Memorandum		3. DATES COVERED (From - To)	
4. TITLE AND SUBTITLE Experimental Lithium-Ion Battery Developed for Demonstration at the 2007 NASA Desert Research and Technology Studies (D-RATS) Program			5a. CONTRACT NUMBER		
			5b. GRANT NUMBER		
			5c. PROGRAM ELEMENT NUMBER		
6. AUTHOR(S) Bennett, William, R.; Baldwin, Richard, S.			5d. PROJECT NUMBER		
			5e. TASK NUMBER		
			5f. WORK UNIT NUMBER WBS 038957.04.07.02.03.03		
7. PERFORMING ORGANIZATION NAME(S) AND ADDRESS(ES) National Aeronautics and Space Administration John H. Glenn Research Center at Lewis Field Cleveland, Ohio 44135-3191			8. PERFORMING ORGANIZATION REPORT NUMBER E-17484		
9. SPONSORING/MONITORING AGENCY NAME(S) AND ADDRESS(ES) National Aeronautics and Space Administration Washington, DC 20546-0001			10. SPONSORING/MONITOR'S ACRONYM(S) NASA		
			11. SPONSORING/MONITORING REPORT NUMBER NASA/TM-2010-216906		
12. DISTRIBUTION/AVAILABILITY STATEMENT Unclassified-Unlimited Subject Categories: 15, 16, 18, and 20 Available electronically at http://gltrs.grc.nasa.gov This publication is available from the NASA Center for AeroSpace Information, 443-757-5802					
13. SUPPLEMENTARY NOTES					
14. ABSTRACT The NASA Glenn Research Center (GRC) Electrochemistry Branch designed and built five lithium-ion battery packs for demonstration in spacesuit simulators as a part of the 2007 Desert Research and Technology Studies (D-RATS) activity at Cinder Lake, Arizona. The experimental batteries incorporated advanced, NASA-developed electrolytes and included internal protection against over-current, over-discharge and over-temperature. The 500-g experimental batteries were designed to deliver a constant power of 22 W for 2.5 hr with a minimum voltage of 13 V. When discharged at the maximum expected power output of 38.5 W, the batteries operated for 103 min of discharge time, achieving a specific energy of 130 Wh/kg. This report summarizes design details and safety considerations. Results for field trials and laboratory testing are summarized.					
15. SUBJECT TERMS Energy sources; Energy storage; Lithium batteries					
16. SECURITY CLASSIFICATION OF:			17. LIMITATION OF ABSTRACT	18. NUMBER OF PAGES 28	19a. NAME OF RESPONSIBLE PERSON STI Help Desk (email: help@sti.nasa.gov)
a. REPORT U	b. ABSTRACT U	c. THIS PAGE U			19b. TELEPHONE NUMBER (include area code) 443-757-5802

