

Chapter 31

Space Applications of Mass Spectrometry

With contributions by

John H. Hoffman
Physics Department
School of Natural Sciences and Mathematics
University of Texas at Dallas
800 W. Campbell Rd. EC 36
Richardson, TX 75080
(972) 883-2846

Thomas Limero
Wyle Integrated Science and Engineering
1290 Hercules Drive, Suite 120
Houston, Texas 77058
(281) 483-7251

Timothy P. Griffin
Material Science Lab (NE-L2)
National Aeronautics and Space Admin.
Kennedy Space Center, FL 32899
(321) 867-6755

C Richard Arkin
Hazard & Gas Detection Lab (ASRC-14)
ASRC Aerospace Corporation
Kennedy Space Center, FL 32899
(321) 867-6758

TABLE OF CONTENTS

31	Space Applications for Mass Spectrometry	3
31.1	Historical Space Applications for Mass Spectrometry	3
31.2	Leak Integrity Testing during Spacecraft Processing	33
31.3	Real-time Leak Detection during Spacecraft Launch Activities	39
31.4	Post-launch Analysis of Engine Performance and Integrity	46
31.5	Gas Analyzers for Metabolic and Physiological Experiments	52
31.6	Gas Chromatograph/Mass Spectrometry: Laboratory Operations.....	60
31.7	In-flight Environmental Use of Mass Spectrometry and Complimentary Analyses	72
31.8	Mass Spectrometers supporting Aerobee and Javelin Rockets.....	96
31.9	Mass Spectrometers Supporting Explorer 31 Argo D-4 rocket flight and the ISIS Satellite Program.....	97
31.10	Mass Spectrometers supporting Apollo Missions.....	100
31.11	Supporting Atmosphere Explorer C, D, and E missions	104
31.12	Pioneer Venus Mission	107
31.13	Mars Phoenix Mass Spectrometer	110
31.14	Reference Information	114
31.15	Acronyms.....	130

31 SPACE APPLICATIONS FOR MASS SPECTROMETRY

Mass spectrometers have been involved in essentially all aspects of space exploration. This chapter outlines some of these many uses. Mass spectrometers have not only helped to expand our knowledge and understanding of the world and solar system around us, they have helped to put man safely in space and expand our frontier. Mass spectrometry continues to prove to be a very reliable, robust, and flexible analytical instrument, ensuring that its use will continue to help aid our investigation of the universe and this small planet that we call home.

31.1 Historical Space Applications for Mass Spectrometry

Provided here is a brief overview of mass spectrometry applications in the American space program and several specific case studies spanning the initial efforts in the 1950s through current day.

31.1.1 Planetary Exploration using Mass Spectrometers

The first applications of mass spectrometry in space were carried out at the US Naval Research Laboratory in Washington DC in the late 1950's. To carry the instruments into space, the Aerobee rocket was developed for high altitude atmospheric and cosmic radiation research in the United States. [31.1.1] It was a small unguided suborbital sounding rocket powered by a single-stage liquid-fueled (nitric acid-aniline) spin-stabilized rocket, which used a solid-propellant rocket motor as a booster. The first live-firing of an Aerobee occurred in November 1947, and by 1950 the Aerobee was in wide use by U.S. military research agencies. The original Aerobee carried a payload of 68 kg to an altitude of 120 km (75 miles). The nose cone containing the telemetry transmitter and the scientific payload was recoverable and returned to earth on a parachute.

Many improvements were made in the Aerobee rocket over the next 10 years. The last of the variants was the Aerobee 150A. It carried 68 kg to an altitude of 270 km (168 mi). Extension sections attached below the nose cone contained scientific instrumentation. Ports allowed the instruments to "look out" normal to the rocket axis, the typical mounting orientation for mass spectrometers. More than 800 of these rockets were flown by the U.S. military and NASA between 1947 and 1985 (when the last Aerobee 150 was launched by NASA). It was a very successful vehicle that provided a soft ride for instrumentation.

The initial instruments adapted to space flight were Bennett radio frequency mass spectrometers to study the composition and number density of the lower ionosphere [31.1.2]. They were flown on Aerobee rockets at the White Sands Missile Range, NM. The Bennett tube mass spectrometers, as they were called, consisted of cylindrical open ended tubes, mounted to look radially outward from the cylindrical rocket section. They did not contain an ion source, but instead a plane grid was mounted on the tube end flush with the rocket's surface that served as a draw in grid to extract ions from the surrounding atmosphere. These instruments were termed ion mass spectrometers (IMS) Mass separation was accomplished by passing ions resonant with the RF field and rejecting others. The sensitivity of this instrument was very high due to the large cross section of the tube, but its mass resolution was just adequate to separate the ionospheric ions. The goal was to study the composition and number density of the ionosphere. The molecular ion species, NO^+ and O_2^+ , dominated the lower ionosphere. At higher altitudes, O^+ and H^+ were observed. Details of the Bennett mass spectrometer are given in Chapter 31.8.1.

Subsequent development of mass spectrometers for space research lead to the miniaturization of laboratory magnetic sector field instruments. [31.1.3] Laboratory versions of these instruments typically had radii of curvature of the ion path in the magnetic field from 6 to 12 inches, while the flight instruments utilized radii in the range of $1\frac{1}{2}$ to $2\frac{1}{2}$ inches. Miniaturized electronics control units consisted of a low-voltage power supply, several high-voltage power supplies, and logarithmic electrometer amplifiers to read the output currents from the instruments. Magnetic sector-field mass analyzers incorporated an ion source that was recessed in the side of the rocket but exposed directly to the ambient atmosphere after reaching approximately 100 km altitude. This configuration came to be known as an open source instrument. The only connection between the ion source and analyzer region was through the narrow slit defining the ion beam. The analyzer vacuum was maintained at a lower pressure than the ion source with a sputter ion pump making operation possible at higher source pressures (lower altitude). Also back-streaming from analyzer to source was minimized as the rocket rotates causing the source pressure to vary by a factor of 1000 in less than 2 sec. allowing the ram and wake gas pressure to be followed.

The first flight of the neutral gas mass spectrometer occurred on June 6, 1963 at White Sands Missile Range on an Aerobee rocket. [31.1.4]. Two magnetic mass spectrometers were employed. One, a double-focusing instrument, included an electrostatic analyzer in tandem with the magnetic analyzer. The

other was a 90° single-focusing magnetic instrument. The two spectrometers were mounted 180° apart in the cylindrical section of the rocket. The rocket reached an altitude of 209 km; the caps covering the ion sources were ejected at 104 km. Since the ion sources were looking outward radially to the rocket axis, the rolling of the rocket produced a continuously changing angle of attack yielding a distinct roll modulation to the data. Results showing the roll modulated spectra for N_2 and atomic oxygen were obtained as were the total particle density as a function of altitude are shown in Figure 31.1.1. Argon and neon peaks show that diffusive separation begins to occur below 100 km rather than above as was generally assumed [31.1.5].

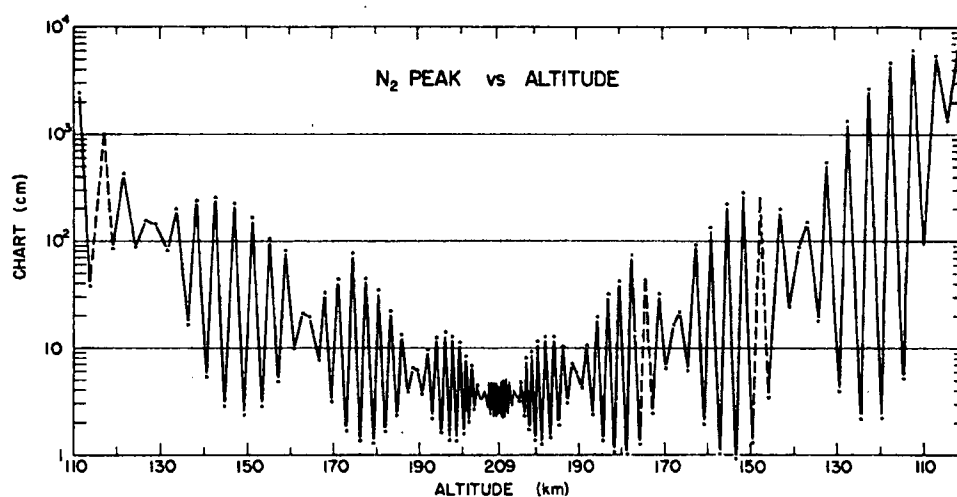

Figure 31.1.1 Roll modulation of the N_2 peak due to continuing change in rocket attitude.

Details of the magnetic mass spectrometers are given in Section 31.9.

Magnetic sector field mass spectrometers were also developed for ionospheric composition studies. The ion source was replaced with a screen mounted flush with the surface of the rocket. The screen was maintained at a negative voltage of typically -6 volts to draw in positive ions from the ionosphere. The object slit of the mass analyzer had to be set at rocket/satellite ground potential mass analyzer. Rather than at the usual sweep high voltage as in a neutral gas instrument since ambient ions have only a few volts of energy due to the rocket motion. The mass analyzer was insulated from the rocket ground potential and was swept from a negative high voltage towards ground potential in order to scan the mass spectrum. The ion detector was an electron multiplier whose input end was at a high negative voltage. The output from the electron multiplier was at rocket ground potential. A logarithmic electrometer amplifier detected the current. Due to the electron multiplier gain, the sensitivity of this instrument was

very high and rivaled that of the Bennett rf spectrometer which achieved its sensitivity due to its wide open geometry. The mass resolution of the magnetic instrument was much higher than that of the Bennett rf instrument. In addition to recording the analyzed ion current, a probe intercepting a fraction of the ion beam leaving the ion source, monitored the total ion current.

Absolute ion density measurements require in-flight calibration of an ion mass spectrometer. One such calibration experiment was done in 1966. [31.1.6] The Explorer 31 satellite was launched via a Thor-Agena rocket along with the Canadian Alouette II satellite that contained a Top-Side sounder that measured electron density vertical profiles in the satellite vicinity while the magnetic IMS on Explorer 31 measured the ion species concentrations. Comparison of the total ion currents with the sounder electron density measurements enabled absolute number densities of ionospheric species to be obtained. Explorer XXXI orbit parameters were perigee 500 km and apogee 3000 km at an inclination of 80 degrees.

In order to obtain simultaneously both horizontal and vertical profiles of ion composition an Argo D-4 (Javelin) rocket flight occurred in the daytime in 1966 timed with an over pass of the Explorer 31 satellite. Both vehicles carried identical magnetic IMSs. The rocket, launched from Wallops Island, VA, reached an altitude of 720 km while the satellite passed over at 970 km. [31.1.7] Extrapolation of the vertical profile of the rocket instrument's total ion density to the satellite altitude provided a calibration comparison with the satellite ion density data. Figure 31.1.2 shows the comparison data from both flights.

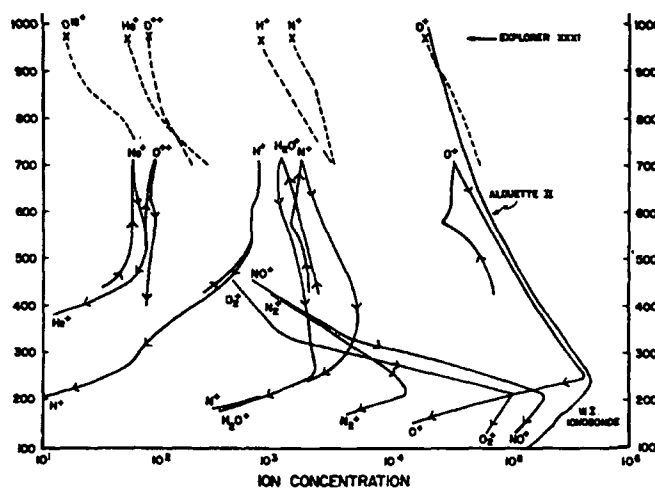

Figure 31.1.2 – Ion concentration as a function of altitude plotted on the Y axis showing both the rocket data (solid lines) and the satellite data (broken lines). x's refer to the satellite data at the point of intersection of the two trajectories.

The orientation of the Explorer 31 satellite in flight was such that its axis of rotation was maintained normal to its orbital plane. It rolled like a wheel along its orbit. The IMS's entrance aperture looking out from the equator of the satellite then lay in the orbit plane so it alternately pointed in the ram and wake directions. This produced a roll modulation in the data. From the offset of the maximum of the H^+ ion current with respect to the ram direction, the outward flow of hydrogen ions was discovered. This flow is known as the polar wind, a flow of ions out to the magnetosphere from the ionosphere. Figure 31.1.3 is a diagram of the roll modulated data.

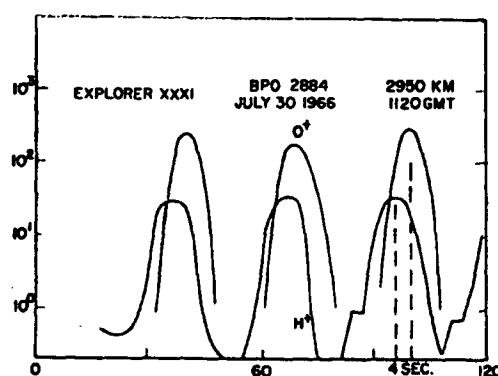

Figure 31.1.3 – Ion concentration (No./CC) versus time (sec.) showing phase difference in the roll modulation maxima of H^+ and O^+ .

The ISIS-II satellite, a joint US-Canadian project was launched in 1971 into a polar constant altitude (1400 km) orbit. It contained a set of instruments including the magnetic IMS that characterized many properties of the topside ionosphere over a period of more than 8 years. [31.1.8] The polar wind upward flow velocity is determined from the shift in the maximum angle between the H^+ and O^+ ions profiles. A description of the magnetic IMS and the techniques used to calibrate the instrument in flight to obtain absolute ion species concentrations are given in Section 31.9.

On another flight of an Argo D-4 rocket, the nighttime ionospheric composition was investigated. [31.1.9] The Lower ionosphere regions, known as the D and E layers, disappear after sunset due to recombination of the molecular ion species, NO and O_2 . Hydrogen ions become the dominant species above 420 km.

The last three Apollo flights to the moon carried magnetic sector-field mass spectrometers to detect the presence of an atmosphere and determine its composition. On the Apollo 15 and 16 flights the

instrument [31.1.10] was mounted in the Scientific Instrument Module of the Apollo Command and Service Module (CSM). This section of the Apollo spacecraft remained in orbit while the descent module landed on the surface. The instrument, a sector-field dual-collector mass spectrometer was mounted on a boom stowed in the SIM bay of the Apollo Service Module which was capable of extending the instrument to a distance of 7.3 meters from the spacecraft. Figure 31.1.4 is a drawing of the configuration. The purpose of the boom mount was to remove the instrument a reasonable distance from the spacecraft that would place it beyond the interacting cloud of outgassing molecules from the spacecraft, and in a collisionless, outwardly free streaming region. The instrument package was a rectangular box, 30 x 32 x 23 cm, weighing 11 kg, bisected by a base plate, with the electronics portion on one side and the mass analyzer on the other. A plenum, in the form of a scoop, was mounted on the outboard side of the package and oriented in the direction of motion.

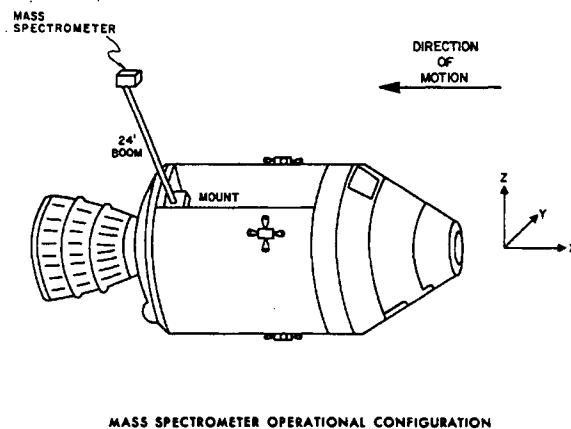
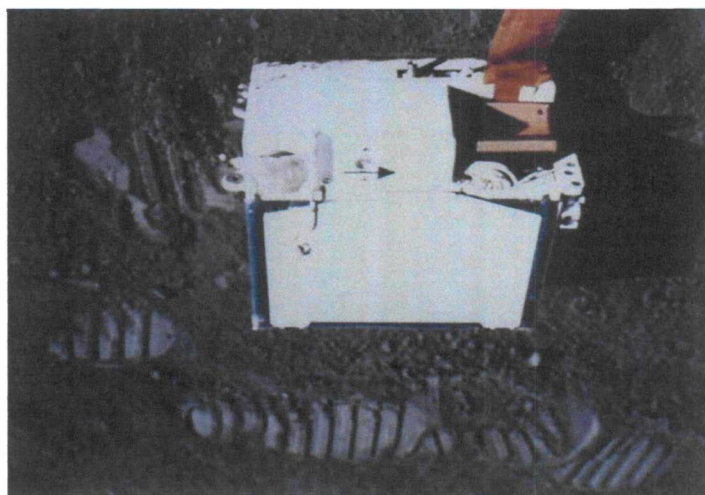

Fig. 31.1.4 – Lunar Command Service Module

The instrument and the boom extension and retraction was operated by an astronaut in the CSM. Measurements of the lunar atmosphere from orbit suffered from the very low density of the atmosphere and the fact that the gases had their origin from the CSM. They were captured in similar orbits around the moon. However, trace amounts of native neon were detected in the lunar atmosphere. See Section 31.11 for details of the instrumentation.

The Apollo 17 mass spectrometer was deployed on the lunar surface as one of the instruments comprising the Apollo Lunar Surface Experiments Package (ALSEP). Figure 31.1.4 is a picture of the instrument sitting on the lunar surface taken by the astronaut [13.1.11]. It operated for nearly one year before a high voltage module corona disabled the instrument.



Picture

Fig. 31.1.4 – Mass spectrometer on lunar surface.

Gas molecules entering the instrument aperture at the lower right corner were ionized by an electron bombardment ion source, collimated into a beam, and sent through a magnetic analyzer to the detector system. In the normal mode of operation, the fixed mode at an electron energy of 70 eV, the sensitivity to nitrogen was 5×10^{-5} A/torr, which was sufficient to measure concentrations of gas species in the 1×10^{-15} torr range. An alternate mode, the cyclic mode, provides four different electron energies (70, 27, 20, and 18 eV) to modify the cracking pattern of complex molecules. Identification of gases in a complex mass spectrum was greatly aided when the spectra were taken at several different electron ionization energies. Also, at low energy, doubly charged peaks were eliminated from the spectrum, thus simplifying the task of identifying parent molecules. A detailed description of the lunar instruments is given in Section 31.10.

Lunar gas density of 10^5 molecules per cm^3 ($\sim 10^{-11}$ torr, $\sim 10^{-9}$ Pa) was detected at night. Argon froze on the night surface and was released in the early morning as the terminator approached the instrument site. Daytime operations were suspended when the temperature rose to the level that the site outgassing saturated the instrument with gas [31.1.12].

Mass spectrometers were flown on three Atmosphere Explorers (C, D, and E) for studying ion and neutral composition and reaction rates within the thermosphere as well as to provide measurements for studying the global structure and dynamics of the neutral atmosphere and ionosphere. Table 31.1.1 lists the flight parameters of the 3 AE satellites. In addition to several mass spectrometers, each spacecraft

carried a retarding potential analyzer and several optical instruments [31.1.13]. See Section 31.1.1 for instrument descriptions.

Table 31.1.1 is a list of parameters for the three Atmosphere Explorer satellites.

Atmospheric Explorer	C	D	E
Launch Date	1973	1975	1975
Orbital Inclination	68°	90°	20°
Features	Stable perigee	Polar- rapid latitude surveys	Equatorial- local time variations
Altitude range	130 to 4000 km	150 to 3000 km	150 to 3000 km

Ion composition studies were carried out with the magnetic sector ion mass spectrometer and the Bennett RF instrument [31.1.1, 31.1.2]. These instruments were similar to those flown on previous rocket and satellite missions. The magnetic ion mass spectrometer had an expanded mass range from 1 to 90 Da utilizing 3 ion trajectories through the magnet that allowed three mass ranges to be scanned simultaneously.

In addition, two neutral gas mass spectrometers, one an open source magnetic sector field instrument, the other a closed source instrument utilizing a hyperbolic rod quadrupole mass analyzer [ref] were flown on the AE series.

The open source instrument was a magnetic sector-field instrument similar to those used in previous rocket flights [13.1.3]. Since the source was exposed directly to the ambient atmosphere, there was minimal, but not zero, interaction of the incoming gas stream (due to the motion of the satellite) with the instrument electrodes prior to ionization by the electron beam. The collisions with source electrodes introduced some uncertainty in relating ambient atmosphere densities with measured particle densities.

The closed source instrument employed a small chamber having a knife edge orifice that connected to the atmosphere [13.1.4]. Gases flowing into this chamber accommodated to the temperature of the chamber walls through collisions. For chemically inert species it was then possible to relate the gas density in the chamber to the ambient density based on kinetic gas theory and knowledge of the vehicle velocity. However, reactive gases like atomic oxygen were lost, i. e., recombined into molecular oxygen or converted into other species like carbon dioxide. Hence the need for an open source mass

spectrometer. The mass analyzer of the closed source instrument was a linear quadrupole type consisting of 4 parallel rods. Rf and DC voltages applied to the rods guided resonant ions (those of a chosen mass to charge ratio) down the axis of the rods to a collector. Non-resonant ions were scattered out of the beam. This type of instrument was first flown on OGO-6 and SanMarco-3 satellites. Instrument details are given in Section 31.11.

In December 1978, seven gas analyzers made in situ measurements of the Venus atmosphere chemical composition. Three mass spectrometers and two gas chromatographs sampled the lower atmosphere (from 65 km to the surface) while two mass spectrometers sampled the upper atmosphere above 120 km from satellites. The lower atmosphere mass spectrometers were flown on the USA Pioneer Venus Multiprobe Sounder probe [31.1.14] and on the USSR Venera 11 and 12 landers [31.1.15]. The gas chromatographs were carried on the Pioneer Venus probe and Venera 12. One upper atmosphere mass spectrometer was on the Pioneer Venus multiprobe bus and one on the Pioneer Venus Orbiter. Several types of mass analyzers were employed in the various instruments. See Section 31.12 for the instrument descriptions. The Pioneer Venus Sounder probe and the Pioneer Venus Bus instruments contained magnetic sector analyzers; the Pioneer Venus Orbiter analyzer was a quadrupole; the Venera instruments had Bennett Rf analyzers. In addition to the neutral gas mass spectrometers, identical Bennett Ion mass spectrometers were incorporated in the Orbiter and Bus.

Shortly after the Sounder Probe encountered the top of the Venus atmosphere and its heat shield ejected by deployment of the parachute, the instruments were activated and data were gathered from this point, at an altitude of 62 km, to loss of signal at the surface. For the first 17 min the probe floated down on a parachute. After parachute jettison an additional 37 min elapsed before the probe reached the surface.

The neutral mass spectrometer on the Sounder Probe [31.1.16] sampled the atmosphere through a pair of microleaks that protruded through the side of the Sounder Probe's aeroshell, beyond the probe's boundary layer, into the free-streaming atmospheric gases. In this way sampling of the atmosphere was free from contamination by vapors emitted from the probe's surface. The two leak's conductance differed by a factor of 10, the larger one being used in the upper more rarified atmosphere. From approximately 50 to 28 km the leaks were blocked by an overcoating of cloud particle materials, presumably by droplets of sulfuric acid cloud particles. During this time the in-flow of atmospheric gases was stopped and mainly background or residual gases in the mass spectrometer were seen, except for SO₂ and H₂O which appeared to originate from the blocking material. Below 30 km the primary

leak reopened (the secondary leak had been valved off by this time), and the atmospheric gas flow returned to normal.

A fortuitous result of the blockage was the opportunity to measure the isotopic composition of the Venus water since the overcoating material was water that condensed from the clouds. The water peaks were very large enabling the oxygen and deuterium/hydrogen ratios to be measured knowing that the water was indeed from Venus. The D/H ratio was 0.016, a hundredfold increase over earth's D/H ratio [13.1.17]. This result means that at least 0.3 percent of a terrestrial ocean was outgassed from Venus, but is consistent with a much greater production.

Data from each of these instruments showed reasonable agreement between the abundances for different gas species, generally to better than a factor of 2 [31.1.18]. One of the principle discoveries was the excess, relative to earth, of the primordial isotopes of the noble gasses, neon and argon by a factor of over 200 [ref]. However, the radiogenic isotope of argon, ^{40}Ar abundance is similar to that on earth. There is also a significance abundance of sulfur compounds below 22 km.

Bennett radio frequency ion mass spectrometer instruments on the Pioneer Venus Bus (BIMS) and Orbiter (OIMS) are identical both electrically and mechanically. [31.12.4] The sensitivity, resolution, and dynamic range are sufficient to provide measurements of the solar-wind-induced bow-shock, the ionopause, and highly structured distributions of up to 16 thermal ion species within the ionosphere. The use of adaptive scan and detection circuits and servo-controlled logic for ion mass and energy analysis permits detection of ion concentrations as low as 5 ions/cm³ and ion flow velocities as large as 9 km/s for O⁺. A variety of commandable modes provides ion sampling rates ranging from 0.1 to 1.6 s between measurements of a single constituent.

The Pioneer Venus Orbiter Neutral Mass Spectrometer (ONMS) was designed to measure the vertical and horizontal density variations of the major neutral constituents in the upper atmosphere of Venus between the altitudes of 150 to 300 km. [31.1.19] A quadrupole mass spectrometer equipped with an electron impact ion source was the sensor employed for the composition measurements.

Each instrument is described in Section 31.12

The neutral mass spectrometer experiment (NMS) carried by the European Space Agency's Giotto spacecraft determined the abundances and the chemical, elemental and isotopic composition of the gases

and low-energy ions in the coma of comet Halley [31.1.20]. The NMS consisted of two analyzers: a double focusing mass spectrometer (M analyzer) and an electrostatic energy analyzer (E analyzer). A unique situation occurred with Halley's Comet. It travels around the sun in a retrograde direction while the Giotto probe having been launched from earth travels in a prograde direction. The relative velocity between the two when passing was 69 km/sec, which equated to 25 eV per Da. Therefore, a water vapor molecule (18 Da) had a kinetic energy relative to the mass analyzer of 450 eV. Consequently an electrostatic analyzer, which is an energy analyzer, became a mass analyzer also. The mass range of the two analyzers was 8 to 86 Da for neutral gas and 1 to 56 Da for ions. The probe passed into a thick sheet of dust particles at 1000km from the comet that caused cessation of the telemetry signal. The signal was recovered after passing the comet nucleus, but most of the instruments and the camera did not survive.

A synopsis of the results showed a predominance of water vapor (80% by volume) in the coma with an H₂O density of 4.7×10^7 molecules cm⁻³ at 1,000 km, a neutral gas expansion velocity of 0.9 km s⁻¹ at 1,000 km and a total gas production rate of 6.9×10^{29} molecules/cm³.

The Cassini mission to Saturn launched in October 1997 arrived at Saturn in June 2004 after gravity assist boosts from Venus (twice), Earth and Jupiter. It carried the Huygens Probe that was released to enter the Titan atmosphere in January 2005 [31.1.21]. It settled through the atmosphere to the surface where it continued to operate for 90 minutes. The probe carried 6 instruments, one being a gas chromatograph-mass spectrometer (GC/MS) that was designed to identify and measure chemicals in Titan's atmosphere. It was equipped with samplers that were filled at high altitude for analysis by the mass spectrometer, a high-voltage quadrupole. During descent, the GC/MS also analyzed aerosols collected by filters and pyrolyzed (i.e., altered by heating). Finally, the GC/MS measured the composition of Titan's surface by heating the GC/MS instrument just prior to impact in order to vaporize the surface material upon contact.

The Huygens probe measured the surface temperature to be -179°C [31.1.22]. Titan rains are mainly methane and ethane. Although Huygens saw no seas of such exotic liquids, lakes of this concoction have now been confirmed at high latitudes. Huygens itself landed in a riverbed, which, although dry at the time of the landing, probably funnels the methane rain off the hills and onto the lower ground. Dark organic compounds containing amino and nitrile groups created in the upper atmosphere also drift down

to coat the moon's surface and mix with ice grains to form sand-like material which settles in longitudinal dunes. Besides methane, there is an abundant amount of nitrogen in the Titan atmosphere but with an isotopic ratio somewhat depleted of ^{14}N indicating that roughly 5 times the present amount of atmosphere has escaped over time. Carbon, which is present in methane does not show such depletion of ^{12}C . This result indicates that methane is continuously being replaced in the Titan atmosphere possibly by cryovolcanism. The discovery of ^{40}Ar in the atmosphere indicated that rock formations exist below the icy mantle and this could be the source of the volcanic emissions into the atmosphere.

The composition of the Mars atmosphere has been explored by three spacecraft whose payload contained a mass spectrometer. In 1976, Viking 1 and 2 landed on Mars at sites 22°N and 45°N respectively [31.1.23]. In each spacecraft there were two double focusing magnetic mass spectrometers, one to sample the atmosphere during the descent to the surface; the other to measure the gases in the atmosphere at the surface and to serve as the gas analyzer for effluents evolved from surface sample heated in a small oven. An arm and scoop dug soil samples from the surface and deposited them in each of 3 containers, one of which was fitted with a heating coil to raise its temperature to 500°C . The analysis was done with a gas chromatograph coupled to the mass spectrometer. One of the goals was to search for hydrocarbons. However, none were found. Atmosphere data showed the presence of nitrogen and argon at the few percent level in the dominant CO_2 atmosphere [31.1.24].

The Phoenix spacecraft that was launched to Mars in August 2007 landed safely on the Martian northern arctic region on May 25, 2008 [31.1.25]. It carried 6 experiments to study the history of water on the planet and search for organic molecules in the icy subsurface Martian soil. Data from the Mars Odyssey Orbiter spacecraft neutron monitor showed large amounts of subsurface water-ice in the northern arctic plains. The spacecraft was a lander with an arm and scoop designed to dig a trench through the top soil to reach an expected ice layer near the surface. One of the instruments, the Thermal Evolved Gas Analyzer, TEGA, consisted of two components, a set of 8 very small ovens that heated samples of the ice-soil mixtures from the trenches to 1000°C to release imbedded gases and mineral decomposition products, and a mass spectrometer that served as the analysis tool for the evolved gases and also for measurements of the composition and isotopic ratios of the gases that comprise the atmosphere of Mars. The mass spectrometer was a miniature magnetic sector instrument controlled by microprocessor driven power supplies. The lander operated for 5 months until, as the season changed from summer to fall, the

solar energy input decreased and temperatures fell, the lander stopped operating. A hard, icy-soil mixture was found 5 cm below the surface covered with a rather fine layer of soil-regolith material. The icy soil mixture was heated in one of the ovens. The presence of water was confirmed in the sample. This was a major goal of the mission. Calcium carbonate and magnesium perchlorate (completely unexpected) were found in the soil samples [31.1.26]. Again, no hydrocarbons were observed. Section 31.13 contains a detailed discussion of the experimental techniques, instrumentation and results.

31.1.2 Mass Spectrometers in the Manned Space Programs – Medical Applications

The manned space program has used mass spectrometry for environmental monitoring and as a tool in medical experiments. Although the environmental monitoring applications of mass spectrometry (next section) now dominate spacecraft operations, it was the medical use of mass spectrometry that first occurred aboard a crewed spacecraft. Skylab was the first “orbital” laboratory with the goal of studying the effects of microgravity on astronaut’s health and performance [31.1.2.1]. Consequently, the medically astute crew participated in numerous medical experiments. The first mass spectrometer was designed to assess the impact of micro-gravity on the body’s physiological response to exercise. Toward this end the mass spectrometer, in experiment M171, named the Metabolic Study Gas Analyzer System (MGAS) measured gases in the expired breath [31.1.2.2]. Data from the Apollo program had shown that most astronauts demonstrated a reduced tolerance for exercise during a period of hours after landing. Was this condition exacerbated as mission length increased? This was a question that had to be studied and addressed before astronauts conducted long duration (months) missions [31.1.2.3].

Measurement of metabolic performance in the laboratory was a complex, multi-step task that required highly-trained physiological technicians to derive accurate results. [31.1.2.4] The MGAS design was driven by the need to convert the complex laboratory metabolic performance measurements into a mostly automated task that could be performed on orbit by crewmembers. The metabolic analyzer had to measure oxygen, nitrogen, carbon dioxide, and water vapor over a wide range of concentrations that was depended on exercise protocol and environmental conditions. Mass spectrometry was considered the best technology for the analyzer, although its complexity was recognized as a difficult design issue for keeping the unit small. [31.1.2.5] At this time NASA was having Perkin-Elmer develop a prototype

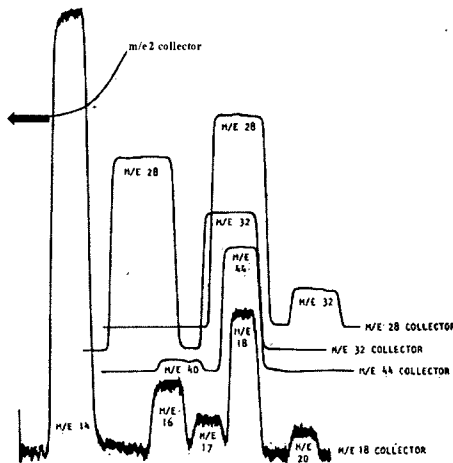

Figure 31.1.2.1 – Typical mass peaks and collector alignment

mass spectrometer for air analysis in spacecraft and it seemed that only a few modifications were needed for it to function as the metabolic gas analyzer. The MGAS analyzer was a single focusing magnetic sector mass spectrometer with a mass range of 2-50 amu, which was sufficient to span the molecular weight range of the target gases (Figure 31.1.2.1). [31.1.2.6] The metabolic pulmonary function was derived from these and other measurements. The results from this experiment and others on Skylab demonstrated man's ability to adapt to the microgravity environment and to quickly re-adapt to Earth's gravity. In this experiment there was a direct correlation between the crew's

extensive exercise on orbit and their short recovery time when returned to Earth; therefore length of stay on orbit need not be a factor in readaption time.

An improved version of the MGAS, called the Gas Analyzer Mass Spectrometer (GAMS) was built for use on Shuttle's biomedical laboratory missions that flew between 1989 and 1995. The GAMS increased the mass range (2-120 amu) and the number of compounds measured to nine (nitrogen, oxygen, carbon dioxide, water vapor, isotopic carbon monoxide, nitrous oxide, argon, helium, acetylene, and total hydrocarbons (m/e 50-120)). [31.1.2.7]

The newest version of the metabolic gas analyzer used on ISS is the Gas Analyzer Metabolic and

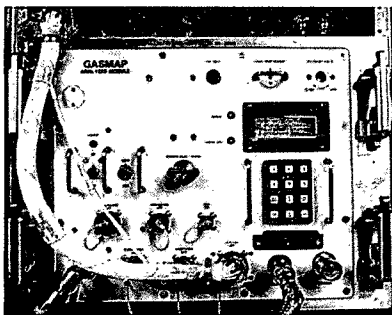

Figure 31.1.2.2 – GASMAP

Physiology (GASMAP), which is a quadrupole mass spectrometer with significantly improved capabilities when compared to the GAMS. The GASMAP was manufactured by Marquette Electronics Industries (MEI). The GASMAP (Figure 31.1.2.2) extended the mass range to include sulfur hexafluoride (SF_6) and it has improved scanning capabilities over the GAMS device. The GASMAP has been used for a number of in-flight physiological experiments, most involving the

use of SF_6 to track respiration capability. [31.1.2.8]

31.1.3 Mass Spectrometers in the Manned Space Programs – Environmental Monitoring Applications

NASA was concerned from the very beginning of the space program about the impact of materials offgassing on crew health. As early as 1963, the Apollo design teams recognized the unique challenge of contamination from materials offgassing in the Apollo command module. For the first time crews in the Apollo command module would be continuously exposed to recycled air in a closed-environmental system. [31.1.2.9] Consequently, a rigorous materials screening program was implemented, which included offgas testing [31.1.2.10] whereby a material's propensity for releasing toxic contaminants was assessed. In 1968, the National Academy of Sciences (NAS) panel on Air Standards identified 200 potential contaminants that might be found in spacecraft air. [31.1.2.11] Another NAS panel established emergency exposure limits for a number of toxic compounds that could accumulate in the spacecraft. The emergency exposure limits were based upon a one-time exposure and permitted some level of reversible symptoms [31.1.2.12], as opposed to the MACs that were set at a no effect concentration.

In 1988, the advent of the International Space Station (ISS) program led to the decision to provide stronger documentation for the Spacecraft Maximum Allowable Concentrations (SMACs). It is

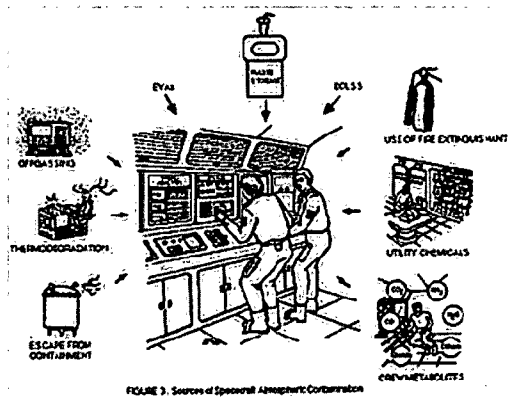

Figure 31.1.2.3 – Sources of contamination on spacecraft

31.1.2.3) aboard a spacecraft, but unknowns are rare due to the effective materials control program.

impossible to set rigorous limits for hundreds of potential contaminants, so the list was culled to a manageable size. Compounds requiring SMACs were either those that had been detected at measurable concentration numerous times in previous archival samples, compounds frequently detected in offgas testing, and/or compounds that were harmful to humans (i.e., benzene) or equipment (catalytic poison) even at low concentrations (parts per billion - ppb). These compounds can arise from a number of sources (Figure

Toxicologists at JSC would propose SMACs, based upon literature reviews, to a National Research Council (NRC) expert panel on toxicology. Following NRC input and discussion, the compound's SMAC document was approved after revisions, if required. The approved SMACs are listed in JSC documents [31.1.2.12], but the full documentation of each compound and the process for establishing

SMACS are published by the NRC. [31.1.2.13-19] The SMAC for a compound is not a single value but a range (1-hr, 24-hr, 7-day, 30-day, and 180-day), which covers different length missions and emergency scenarios. Like the previously mentioned emergency exposure limits, only the 1-hr and 24-hr SMACs allowed temporary, minor/mild crew symptoms to occur.

The purpose of the ground-based analysis of archival samples and the more recent real-time monitoring of spacecraft contaminants is to assess the air quality during crewed missions (acceptable or established limits were exceeded). Furthermore, the SMACs are used in the calculations of the offgas testing to identify items that could release contaminants at unacceptable concentrations. These tests are a required part of the flight hardware certification for materials, assembled items, and modules.

31.1.3.1 Groundbased GC/MS Analysis of Samples

Early manned spaceflight vehicles (Mercury, Gemini, and Apollo) were too small to accommodate instrumentation for atmospheric composition or air quality measurements, other than electrochemical sensors for critical gases such as oxygen. Consequently, the initial application of mass spectrometry for manned missions occurred in ground-based laboratories. Characterizing the types of pollutants released into spacecraft during a mission was first achieved through analyses of the contaminants collected on the spacecraft air scrubbers. [31.1.2.20-21] The improvements to GC/MS in the late 50s and early 60s was quickly establishing it as an excellent method for analyzing complex mixtures of VOCs; therefore it was only logical for NASA to adopt GC/MS for analysis of spacecraft air contaminants. [31.1.2.22] An important advantage of GC/MS analysis for NASA was the instrument's ability to accurately identify compounds in a mixture, since the contaminants released into spacecraft air were not known. The charcoal analyses weren't quantitative, but they did provide valuable information on contaminants in a spacecraft environment. Within the limits of the technique, the analyses of Apollo samples showed acceptable cabin air quality, which meant the materials control program and the Environmental Control and Life Support (ECLS) system were effective in controlling pollutants. [31.1.2.23]

Skylab was the first U.S. spacecraft in which direct samples of the spacecraft atmosphere were acquired and returned to the ground for analysis. Skylab (1972-1974) signaled a change in spacecraft from mainly a means of transportation to a habitation facility and workplace [31.1.50]. The Skylab program

saw the development of the first archival air samplers specifically designed to trap the VOCs in the air rather than rely upon the analysis of accumulated VOCs in the scrubber's charcoal [31.1.51]. The samples were returned to the ground and analyzed by GC/MS. Of the 300 compounds detected, 107 were identified with molecular weights ranging from 60-584 amu.

The Shuttle was a relatively small vehicle that could house up to seven people for 30 days and the worries about increasing trace contaminant levels in such a "crowded" vehicle led to a rigorous archival air sampling strategy. The Shuttle's main sampling device is a grab sample container (GSC) shown in figure 31.1.2.4 , but a Solid Sorbent Air Sampler (SSAS) was also flown on the first mission of a new or refurbished Shuttle. The SSAS was designed (Figure 31.1.2.5a and b) to acquire seven, 24-hour samples during a mission. The Solid Sorbent Air Sampler (SSAS) contained eight glass-lined stainless steel Tenax-filled tubes that were connected to a 16-port, 8-position stainless steel Valco rotary valve [31.1.2.26-27].

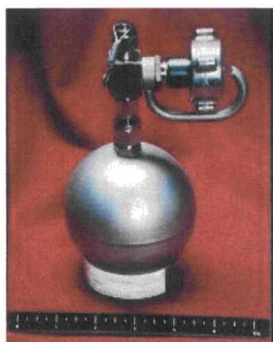

Figure 31.1.2.4 – GSC



Figure 31.1.2.5a – Solid Sorbent Air Sampler



Figure 31.1.2.5b – SSAS on orbit

This valve isolated the tube, once the sample was acquired, thus preventing cross-contamination of the sample. In addition to the aforementioned Shuttle flights, the SSAS was used on the medical sciences laboratory and longer duration Shuttle flights from 1985-2003 and also on MIR and ISS during this time period.

The GSC is a standard 300 ml Summa™-treated canister that is similar, albeit smaller, than the canisters used by the Environmental Protection Agency (EPA) for collection of trace volatile organic compounds (31.1.2.28). These samplers provided data on VOCs as well as other more volatile spacecraft air

contaminants, such as carbon monoxide and carbon dioxide, that aren't trapped by the sorbent tube samplers (SSAS).

A GSC sample (pre-flight) is acquired in the crew cabin before launch and a flight GSC is used to sample the cabin on the last day of flight. A third GSC is reserved for contingency situation (odor, smoke, etc.) during the mission. Upon return of the samples to the Toxicology Laboratory at JSC, several GC runs are performed to analyze for the lighter gases (CO, CO₂, CH₄, and H₂) and the hydrocarbon loading.

The bulk of the trace contaminant analysis from the GSCs is performed on a gas chromatograph/mass spectrometry (GC/MS) system (Figure 31.1.2.10). The Toxicology laboratory has adopted modified versions of TO-14/TO-15 (GSC analysis) and TO-1/TO-17

(sorbent tube analysis) methods. [31.1.2.29] Modifications are needed to address the constraints of spaceflight, such as limited availability of duplicate samples and trip controls.

Nominally, a 100 cc sample is obtained from the GSC by an Entech7100 Preconcentrator system, which concentrates the VOC while removing water and CO₂ in a series of traps. The final desorption from the Entech sends the sample plug of

VOCs to a GC column (150 m DB-1) in an Agilent 6890N GC. The GC is connected to an Agilent 5975 quadrupole mass spectrometer.



Figure 31.1.2.10 – An operator performing AIS/GC/ MS analysis

In addition to Shuttle, the GSCs are also part of a larger suite of analytical tools for assessing the quality of the atmosphere on ISS. Three GSC samples are acquired each month with one sample rotated among the various modules and the other two samplers always used for the U.S. Laboratory (LAB) and Russian Service (SM) modules. The samples are returned to Earth via the Shuttle approximately every three months (total of 12 samplers per mission). The analyses on these samplers are conducted as presented for the Shuttle GSCs

A NASA grant had propelled Pete Palmer, a researcher at San Diego State University, to conduct an investigation of mass spectrometry techniques for analyzing air contaminants. Dr. Palmer assessed GC/MS, TD(thermal desorption)/GC/MS, and MS/MS as possible means to achieve analysis of a wide variety of contaminants in spacecraft air. [31.1.2.30] Later, Dr. Palmer analyzed several samples returned from the MIR spacecraft by Direct Sampling Ion Trap Mass Spectrometry (DSITMS), which has the advantage of very fast analysis by a much less complex instrument (no GCs and associated gases). The analyses of the MIR samples showed the potential of DSITMS to detect the pollutants at levels well-below the SMACs and to analyze a broad range of compounds. [31.1.2.31] Ultimately, ground analysis continued with GC/MS because the EPA had developed their methods around this technique and it provided a documented and verifiable analysis.

31.1.3.2 Inflight Use of Mass Spectrometry

Interestingly at the time Perkin-Elmer was developing the MGAS, the U.S. Navy was looking for a submarine atmospheric monitoring system, because the system being used at the time was unreliable. The U.S. Navy saw potential for the MGAS to meet their needs with minimal modifications. Trial results convinced the Navy to have Perkin-Elmer build a similar system for submarine atmospheric monitoring. [31.1.2.32] The first version built was the Central Atmosphere Monitoring System Mark I (CAMS)-I, which performed as expected, but has since been replaced by an improved version, the CAMS-II. [31.1.2.33]

The pedigree for the International Space Station's Major Constituent Analyzer (MCA) is from the MGAS and the U.S. Navy's CAMS and as such it is a single-focusing magnetic sector mass spectrometer. Designed to monitor the major constituents (oxygen, nitrogen, hydrogen, carbon dioxide, methane, and water vapor), it became the first mass spectrometer used for routine environmental monitoring on a manned spacecraft. [31.1.2.34] The data from the MCA is used to meet two necessary ISS requirements: 1) feedback for environmental control and life support (ECLS) systems and 2) verification that oxygen concentration meet medical requirements and that carbon dioxide and methane concentrations are below toxicological limits (SMACs).

The MCA (Figure 31.1.11), built by Perkin-Elmer (later Orbital Sciences), was comprised of seven on-orbit replaceable units (ORUs). [31.1.2.35] The ORUs (detailed description in section 31.2.7) have been essential to maintaining operation of this critical piece of equipment. The MCA has a calibration gas that is used to check and adjust the MCA's calibration once per week. MCA provides the feedback information to control the oxygen concentration in all situations onboard ISS. During Extravehicular Activities (EVAs), the oxygen concentration in parts of the ISS is adjusted for this lower pressure activity and tight control of the oxygen levels is important not only for crew health, but also for resource management. The MCA accuracy requirements are shown in Table 31.1.2.1. As will be discussed in section 31.7, the water accuracies for water and carbon dioxide were changed to "non-specified" and $\pm 3\%$. Other activities, such as docking spacecraft or a failure of a primary oxygen generation system (Russian Elektron and U.S. OGS) can alter the ISS oxygen concentration. If the addition of oxygen is

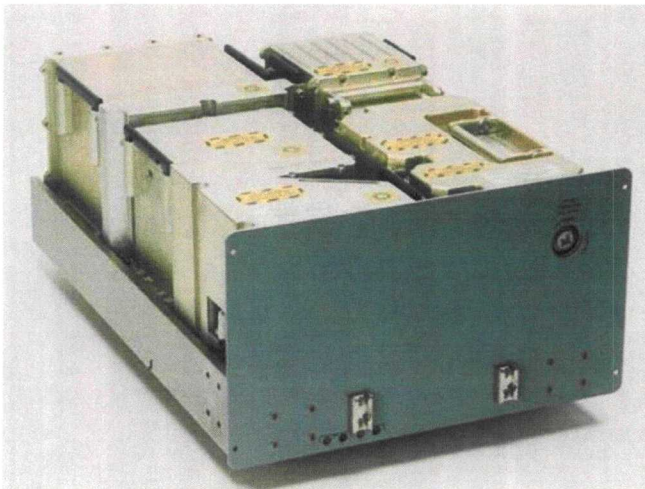

Table 31.1.2.1: MCA Range and Accuracy requirements

Monitored Gas	Range (Torr)	Accuracy (%FS)
Nitrogen	335 – 800	± 2
Oxygen	0 – 300	± 2
Hydrogen	0 – 50	± 5
Methane	0 – 25	± 5
Water	0 – 25	± 5
Carbon Dioxide	0 – 15	± 1

Figure 31.1.2.11 – Major Constituent Analyzer

then reserve oxygen can be depleted quickly in the large ISS volume. Additionally, the MCA's measurements provide a means to monitor the performance of the carbon dioxide scrubbing systems (Carbon Dioxide Removal System-CDRA and Vozduk-Russian CO₂ removal system) and to verify that CO₂ levels are maintained below the established SMACs.

31.1.3.3

Complementary Techniques

The International Space Station (ISS) presented a different operational scenario with its envisioned large habitable volume and planned lengthy stays on orbit for crewmembers that demanded real-time air quality monitoring. The frequency (~4 times per year) of spacecraft visits to ISS meant that gaps in

assessing the air quality could easily stretch to 3 - 6 months before archival samplers were returned and analyzed. Consequently, the Crew Health Care System (CheCS) and the ECLS groups had documented requirements to monitor trace contaminants in ISS for crew health and system performance evaluation, respectively.

The Toxicology group was charged with defining the requirements and identifying potential technologies for air quality monitoring aboard ISS, which included trace contaminant monitoring. In the late 1980s, the primary effort of the Toxicology group was directed toward a gas chromatograph/ion trap detector system, which seemed to be a system that could be “shrunk” to a size accommodated by ISS. In the early 1990s, three converging events completely changed the Toxicology Laboratory’s direction away from mass spectrometry and toward ion mobility spectrometry (IMS). The first was the recognition by the NASA toxicologist that it was unnecessary, from a crew health perspective, to monitor 200 compounds. In fact, a list of 25-30 compounds seemed sufficient to address both crew health and ECLS needs. The 2nd event was the recognition that ion mobility spectrometry (IMS) might be useful in the detection of VOCs in spacecraft atmosphere. Several successful flights to monitor hydrazine by IMS (Figure 31.1.2.12), using a modified Chemical Agent Monitor (CAM) from Graseby Dynamics, demonstrated the appropriateness of the technology for spaceflight. [31.1.2.36]



Figure 31.1.2.12 – Hydrazine monitor being used in the airlock following an EVA

It seemed that IMS could be a viable candidate for trace contaminant monitoring, if a GC column could be mated with the detector. [31.1.2.37] The final event was the reduction in allocated power for equipment on ISS. The ISS program realized there was a significant deficit between the power requested by users and the projected ISS power that would be available. In 1992, the Toxicology Laboratory funded the manufacture of a breadboard volatile organic analyzer (VOA) to show the potential of IMS to meet the trace contaminant monitoring requirements. The breadboard was demonstrated for McDonnell-Douglas, the prime contractor for the ISS CheCS program and they were impressed with its performance and small size.

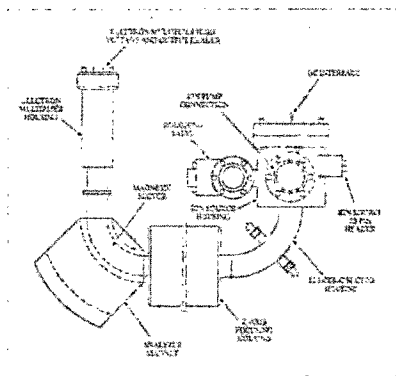

Figure 31.1.2.13 – TCM's mass spectrometer

The ECLS group was planning to include a trace contaminant monitor (TCM) as part of their overall monitoring system. The TCM design (Figure 31.1.2.13) used the double-focusing mass spectrometer system employed so successfully in the Viking program. [31.1.2.38]

The ISS program reasoned that one instrument could meet ECLS and CHeCS requirements and that they could only afford (cost and resource) one trace contaminant monitor. Breadboards of both technologies (GC/MS and GC/IMS) had been built and they generated modest amounts of data, but neither produced definitive evidence of superior performance. After several years of meetings, data presentations, and significant work by both teams, the decision to select the VOA was ultimately based upon monetary considerations: the VOA was far cheaper than the TCM.

The flight VOA, built by Graseby Dynamics (now SmithsDetection), was comprised of redundant preconcentrators (carboxen and carbotrap), 60-meter GC columns, and identical ion mobility spectrometers. [31.1.2.39] All of this was squeezed into a 0.042 m^3 (1.5 ft^3) package that weighed approximately 50 kg (110 lbs). The GC carrier gas was nitrogen plumbed from the ISS nitrogen reserve. The two-channel VOA provided a system that could lose one channel and still provide approximately 90% of its performance. The VOA was calibrated for its target compounds (Table 31.1.2.2) prior to launch.

The VOA (Figure 31.1.2.14), using GC/IMS technology, was launched to ISS in August 2001.



Figure 31.1.14 – VOA on orbit

Compound Name	Compound Name
Methanol	Ethanol
1-butanol	2-methyl 2-propanol
Ethanal	Benzene
m,p xylenes	(F22) chlorodifluoromethane
o xylene	1,1,1, trichloroethane
Toluene	(F113) 1,1,2-trichloro-1,2,2-trifluoroethane
Dichloromethane	Hexane
Propanone	
2-butanone	Isoprene
ethyl acetate	(halon 1301) trifluorobromomethane
2-propanol	

Table 31.1.2.2: VOA Target Compounds

The VOA encountered communications problems in the first 6 months on orbit, but the problems were solved by Spring 2002. The VOA developed a serious problem toward the end of 2003 when blown fuses disabled both channels of the instrument. [31.1.2.40] In 2005, an in-flight maintenance (IFM) replaced the blown fuses and the VOA (at least one channel) provided data from January 2006 through August 2009 when it was decommissioned. [31.1.2.41] The VOA supplied key data following the METOX incident in February 2002 [31.1.2.42] and after the Elektron (oxygen generation system) overheating in the Russian SM in September 2006. [31.1.2.43] These are discussed in greater detail in section 317. Although these were the high profile incidents, it should be noted that the VOA produced data on air quality during the early critical period after the Columbia accident (2003), when it was nearly impossible to get GSC samples returned.

Representative VOA data and its comparison to GSC analysis for ethanol and n-butanol during 2007 are shown in Figures 31.1.2.15a and 31.1.2.15b. Some compounds, such as ethanol, have fluctuating concentrations and others, such as n-butanol, have low, relatively stable concentrations in the spacecraft.

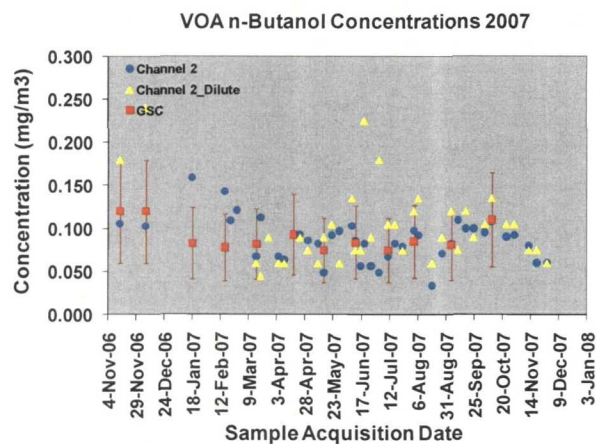
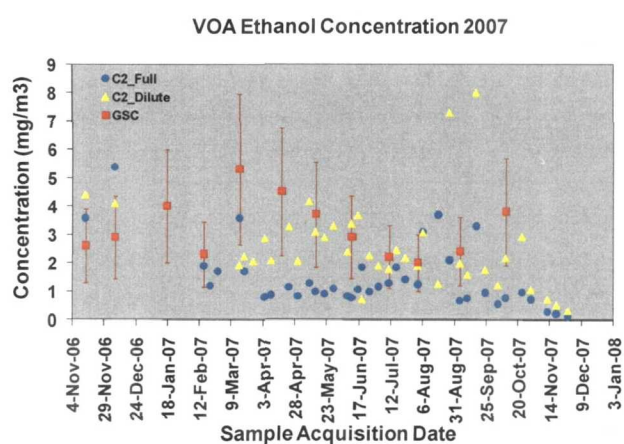

Figure 31.1.2.15a – ISS ethanol concentration 2007

Figure 31.1.2.15b – ISS n-butanol concentration 2007

The VOA, as a field-portable trace VOCs instrument, was a powerful analytical tool for its time; but the march of technology and the transition of NASA's mission to Exploration pointed to the need for a next generation device. The VOA was very reliable, with no component (except the fuses added very late in the design) failing until 3 years after its design life (5 years). Furthermore, with only minor adjustments to calibration curves, the VOA quantification capability continued to meet requirements (see section 31.7. for its entire 8 years on orbit without recalibration. On the negative side, the VOA was large and complex, which precluded easy on orbit repair or replacement. Reliance on ISS resources (nitrogen, rack cooling, data, and power) limited the use of the VOA at crucial times, such as when the Shuttle was docked. Finally, the VOA was a custom instrument, which meant this was the "beta" version and it was expensive to build and maintain.

It was with the aforementioned drivers in mind that the Toxicology Laboratory began investigating a new technology in the mid 2000s called differential mobility spectrometry (DMS). [31.1.2.44] This detector technology was derived from ion mobility spectrometry, but a great reduction in size and an increase in sensitivity could be realized with DMS technology. Furthermore, DMS appeared to achieve greater resolution for lower molecular weight molecules, which included most of the compounds in Toxicology's target list. Sionex introduced the microAnalyzer™, a smaller version of the previous GC/DMS system. [31.1.2.45] This system was 1/10th the size and weight of the VOA and it was recognized as a leap forward in the technology of field-deployable VOCs analyzers. One advantage of this system is that air is used as the carrier gas, so pressurized cylinders of carrier gas are not required.

This not only eliminates a consumable and a large gas cylinder, but it drastically shrinks the instrument, because of simplified valving and pneumatic flows. In 2008, two of these units were certified and calibrated (triplicate at 5 concentration points) for manifesting on ISS as a Station Detailed Test Objective (SDTO) experiment. The two units arrived on ISS in February 2009 and one unit was activated in May 2009 (Figure 31.1.2.16). This SDTO is undergoing evaluation for possibility replacing the VOA function on ISS and for 8 months the unit has performed well. Representative GC chromatograms from the first 4 months on orbit are shown in Figure 31.1.2.17.

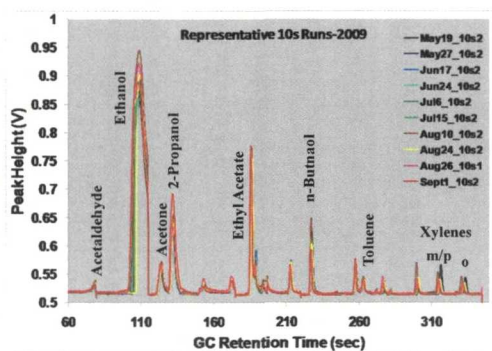

Figure 31.1.2.16 – microAnalyzer SDTO(circled) on orbit

Figure 31.1.2.17 – Representative GC traces from four months of microAnalyzer runs

The Vehicle Cabin Air Monitor (VCAM) is scheduled to be sent as a technology demonstration to ISS in March 2010. [31.1.2.46 and 47] The VCAM has a gas chromatograph (10m carbowax column) connected to a Paul ion trap. It has a miniaturized inlet and preconcentrator (carboxen 1000) and the vacuum is provided by a small roughing pump and turbomolecular pump. The VCAM has the onboard processing capability to analysis the data and report the findings. The carrier gas (helium) and calibrant mixture are items that must be replaced about once per year. The VCAM was designed to measure both major constituents (O_2 , N_2 , etc.) and a target list of trace VOCs. The VCAM will be the first evaluation of mass spectrometry used to measure trace organic contaminants in spacecraft air. An advantage of mass spectrometry is its recognized capability to identify unknowns by comparison of the unknown's spectrum to library spectra.

31.1.4 Using Mass Spectrometers for Launch Vehicle Processing

Vehicles and payloads in the aerospace industry often use mass spectrometer-based gas analysis for leak integrity testing and hazard mitigation monitoring to ensure the safe operation of launch vehicles.

In general, heavy lift rockets use liquid hydrogen (LH₂) and liquid oxygen (LO_x) as propellants. These commodities represent several hazards, primarily due to their wide flammability range. When loading a vehicle with LH₂ or LO_x, it is common to purge the storage areas, transfer lines, and vent lines with either nitrogen or helium. Initially, a purge is used to remove contaminants, primarily oxygen and water. This purge is continued throughout the fueling operation and only ends when the operation is completed (such as vehicle launch). The purging process prevents contamination, vent propellant vapors controllably, and dilutes a possible leak below hazardous levels if integrity is lost. It is often important to monitor for hazardous commodities in the parts-per-million levels, well below the percent levels required for flammability. The low concentration monitoring is needed, because of the intentional dilution of the purge gas and the fact that most of the leak checks are preformed with the systems at pressures well below that utilized during operation. Therefore, it is necessary to monitor these commodities at part-per-million (ppm) levels and extrapolate the results to what leak rate is occurring at the source and while under operating pressures. These leak detections have proven invaluable and are credited with saving multiple vehicles and human lives.

A variety of systems, under the general description of Hazardous Gas Detection System (HGDS), are used to perform these leak tests. At a minimum, these systems need to quantitatively monitor hydrogen, helium, nitrogen, oxygen, and argon. Hydrogen and oxygen are monitored due to flammability hazard. Nitrogen is also monitored since it is a purge gas, which is important to determine if there is a leak between helium and nitrogen purge cavities and for occasional specialized tests. Helium is monitored both as a purge gas and as a leak test tracer gas. Argon is monitored to determine if oxygen originates from a propellant leak source or air intrusion. These ground-based systems have their own sample delivery subsystems, computer control, data acquisition, and mass spectrometers. Mass spectrometry is the best choice as the detection method for these commodities since, it is ideally suited for qualitative as well as quantitative analysis; it is robust, and it can be incorporated into a remotely operated system. Essentially no other instrument can identify and selectively quantify helium and other components simultaneously. Mass spectrometers also provide quantitative information and typically have linear dynamic ranges of 5-orders of magnitude or more. Mass spectrometers also have rapid response times, with sub-second response and recovery times being common.

In the early 1960s, NASA began to use mass spectrometers for vehicle leak detection with the Saturn Hazardous Gas Detection System (HGDS), which was first used on Saturn I launches from Launch Complexes 34 and 37. This same type of system was then used to support the Saturn V missions beginning with Apollo 4, the first unmanned test flight on 9 November 1967. The Saturn-HGDS monitored hydrogen, helium, oxygen, and argon, consisted of a diffusion pumped residual gas analyzer, and a had a sample delivery system allowing leak integrity monitoring of the S-IC, S-II, and S-IVB engines, Instrument Unit, and interstage areas. Installed in the lower level of the Mobile Launch Platform (MLP), it was operational from the initiation of propellant (liquid hydrogen and liquid oxygen) flow until start of the cold helium purges of the S-II and S-IVB engines just prior to launch. The system was maintenance intensive, and required external services such as running water and liquid nitrogen to protect the analysis region from the diffusion pump's hot oil, but it never caused a launch countdown hold or delay of any kind. Although only minor leakage was detected during the Apollo program, the HGDS became an integral part of NASA launch operations ground support equipment.

As was the case for the Saturn vehicles, the primary role of mass spectrometer ground based systems in the Space Shuttle Program has been the detection of cryogenic leaks before they become a hazard. And like the Saturn system, these ground-based systems have their own sample delivery subsystems, computer control, data acquisition, and mass spectrometers. There are currently a number of systems being used to process and monitor the Orbiters before each launch, which have proven invaluable in helping to ensure safe launches and have been credited with saving several vehicles: STS-6 [31.1.4.1], STS-35 [31.1.4.2], STS-38 [31.1.4.3], STS-73 [31.1.4.4], STS-93 [31.1.4.5], STS-113 [31.1.4.6], STS-119 [31.1.4.7] and STS-127 [31.1.4.8, 31.1.4.9].

The Space Shuttle Hazardous Gas Detection System was required for hazardous gas detection in all purged compartments. The prototype Shuttle HGDS called for incorporating a commercial mass spectrometer with a control and data acquisition subsystem into a NASA designed sample transport subsystem, and the ability to monitor and control the system in the Launch Control Center (LCC) two miles away from the HGDS. Toward this end, NASA Engineering at KSC conducted an exhaustive review of available mass spectrometry technologies, and eventually selected the UTI Q30C. The instrument arrived at KSC in December 1975, and was integrated into the complete system during 1976. The unit was extensively tested for functionality, detection limits, dynamic range, long term drift, and

other typical instrumental performance characteristics [31.1.4.10]. The prototype HGDS was shipped in May 1977 to the Stennis Space Center to support the test firings of the Space Shuttle Main Engines, where it remained in use for about twelve years, supporting testing of upgraded engines. The first operational HGDS (the “Prime” HGDS system) had four continuously pumped sample transport lines, pressure and flow health check sensors, the well proven UTI Q30C/100C mass spectrometer system, an ion pump based vacuum chamber, and three synchronized microprocessors for control and data acquisition. KSC in-house software for these microprocessors proved to be the most challenging aspect of the project as the top-level software was written in a Pascal-like language, and IO functions were written in machine code. System installation on Mobile Launch Platform 1 (MLP-1) began in summer of 1979, and the system was ready to support initial propellant loading tests in late 1980.

The Prime HGDS [31.1.4.11] proved to be quite capable of detecting and measuring very small leaks from the Orbiter Main Propulsion System. Each Orbiter seemed to have its own characteristic total leakage rate, typically 150-300 parts per million (ppm), all well within allowable limits. Before the maiden flight of the Shuttle Challenger, a Flight Readiness Firing Test was required to ensure that all main systems operated correctly. In this test, the countdown would proceed normally to T-0, the Orbiter main engines would ignite, but the Solid Rocket Booster engines would not ignite, and the Shuttle would remain bolted to the launch pad during a twenty second firing of the main engines. During this Flight Readiness Firing test, the HGDS detected a leak exceeding the allowable leakage by more than an order of magnitude during the engine firing phase. Subsequent ambient temperature helium leak tests at engine joints did not reveal significant leakage. A second Flight Readiness Firing Test was performed on 25 January 1984 with additional sample lines into the Orbiter aft fuselage to determine the leak location. Following additional analysis the leak was identified as a deteriorated weld repair on one of the main engines. In addition, faults were revealed in a number of the vehicle shuttle main engines, and a program wide recertification ensued. The propulsion division chief for shuttle launch operations subsequently stated that “...all the money spent on the HGDS, and all that would ever be spent, was paid for in those 20 seconds when the leak was detected.” [31.1.4.12] Challenger successfully launched on 4 April 1983.

Due to the successes of the HGDS in demonstrating leaks, it was decided that redundancy was required. After a detailed engineering analysis, followed by laboratory testing of candidate mass spectrometers,

the decision was made to use the Perkin Elmer MGA-1200 fixed sector as the basis of the Backup HGDS. A successor of the Navy's Central Atmosphere Monitoring System (CAMS) system [31.1.4.13], the MGA-1200 was an ion pumped, multiple collector, fixed magnetic sector that was becoming widely used in medical and industrial applications. The first systems were delivered in late 1985, and the first launch supported was on 29 September 1988 when the original and Backup HGDS systems successfully supported the Return-to-Flight activities following the Challenger accident.

In May 1990, a hydrogen leak was detected in the Orbiter Aft Fuselage and at the External Tank Orbiter Hydrogen Umbilical Disconnect on STS-35 [31.1.4.2]. As a precaution, tests were performed on the STS-38 vehicle as well, and leakage was also identified at the Hydrogen Umbilical Disconnect. After a series of tests of both vehicles, each with increased instrumentation, the leak was finally located, repaired, and STS-35 lifted off for a successful mission on 9 December 1990, and STS-38 on 15 November 1990. Following the STS-35 and STS-38 leak issues, it was determined that a new system had to be developed to monitor helium purged areas, something that ion pump based mass spectrometer systems cannot achieve. This new Hydrogen Umbilical Mass Spectrometer (HUMS) system was specifically designed to monitor the several hydrogen umbilical lines that load and unload fuel to the vehicle. On 7 May 1992, the prototype unit supported the Flight Readiness Firing of the new Endeavor Orbiter. Similar to the HGDS Backup, the Perkin Elmer MGA-1200 was again selected as the mass spectrometer, this time with a turbo-pump instead of an ion pump. The system was designed to monitor up to 8 sample lines, with a later modification to allow up to 21 sample lines. The computer control and operation utilized the latest technology including touch screen local operation and full remote operation. The addition of the HUMS greatly increased the capabilities of the HGDS suite of systems, making it a requirement that three mass spectrometers be utilized for the launch of each Shuttle. The HGDS utilized by NASA proved so successful that the United States Air Force incorporated a similar design for their Atlas V rocket.

In the 1997, a project began to replace the aging and unserviceable Primary and Backup HGDS units with a single system – the Hazardous Gas Detection System 2000 (HGDS 2k). The design of the system [31.1.4.14] incorporated commercially available components into an overall system specifically designed by KSC Engineering to meet redundancy requirements. The new system had to meet or exceed all of the requirements of the old systems including the need to monitor and control from the

LCC. The system consisted of two fully independent mass spectrometer subsystems, including the control computers, which utilize a common sample transport subsystem. The mass spectrometer subsystem utilized a Stanford Research Systems (SRS) single quadrupole RGA 100 and a custom designed vacuum system. HGDS 2k prototype first supported launch in summer 2000, and completely replaced the Prime and Backup HGDS units by 2001.

As NASA is starting a new era in human space exploration, mass spectrometry based systems continue to help place people and payloads into space. New systems incorporating the latest in mass spectrometer technology are being designed for the next generation launch vehicles that will propel humans to the moon and beyond.

Since the United States first sent rockets toward space, mass spectrometers have helped us to better understand our world and our solar system. The United States Space Program has utilized mass spectrometers to monitor the atmosphere of not only earth but of other celestial bodies, to help ensure safe breathing air for astronauts, and to safely launch vehicles into space. Such a wide range of uses is only possible because of the flexibility, robustness, and growth potential of mass spectrometers. The enduring qualities will ensure that mass spectrometers will continue to help us explore our world, or solar system, and eventual the universe.

31.2 Leak Integrity Testing during Spacecraft Processing

Leak integrity testing is a critical aspect of spacecraft processing. Many fluids are required to launch and operate a spacecraft and these fluids typically include hydraulics, propellants (such as hydrogen, kerosene, oxygen, hydrazine and nitrogen tetroxide), and purge gases (e.g. helium, argon and nitrogen). Normally, spacecraft operations include fluids for life support (nitrogen, oxygen, carbon dioxide), pressurization (helium, argon and nitrogen), and thermal management (ammonia, Freon). When a vehicle is processed prior to launch, various leak integrity tests are performed to ensure that systems function as intended. It is common to perform leak detection using helium as the tracer, and several monographs discuss the subject in detail [31.2.1, 31.2.2]. However, the identification of leaks using argon is rare, but an example of such an application is leak testing a Star Tracker unit. A Star Tracker system (Ball Aerospace, Boulder, CO), which is part of a vehicle's navigation system, has sensitive optics and electronics requiring pressurization with argon. The Star Tracker unit was found to be leaking argon at an unacceptable rate: an estimated leak rate of 8×10^{-5} sccs (standard cubic centimeters per second) compared to the designed maximum leak rate of 2×10^{-6} sccs (3 months compared to 10 years of operation). A mass spectrometer system was prepared as an argon leak detector to locate and resolve the leak issue.

Detection and quantitation of a leak into an uncontrolled environment is a difficult task not only to perform in application, but also to model. A very rough and simplistic model is presented here (Figure 31.2.1), where Q_{Leak} is the molar flow rate [31.2.3] and P_{sys} , V_{sys} , and T_{sys} are the pressure, volume and temperature of the leaking system. With t as time, Equation 31.2.1 is the leak rate equation, using the ideal gas approximation. (Note that $R = 8.31447 \frac{\text{cm}^3 \cdot \text{MPa}}{\text{K} \cdot \text{mol}}$.) Once the pressurized gas leaks out to the environment, it will displace the ambient gas near the leak position. For this model an hemispherical displacement volume (V_{smp} , Equation 31.2.2) is used, where r is the distance between the leak source and the sample uptake probe. With this model, one can approximate the argon tracer gas concentration change, $\Delta[31.1.3.r]$, as given in Equations 31.2.3 – 31.2.5. (Note that time, t , in this model is intended to be

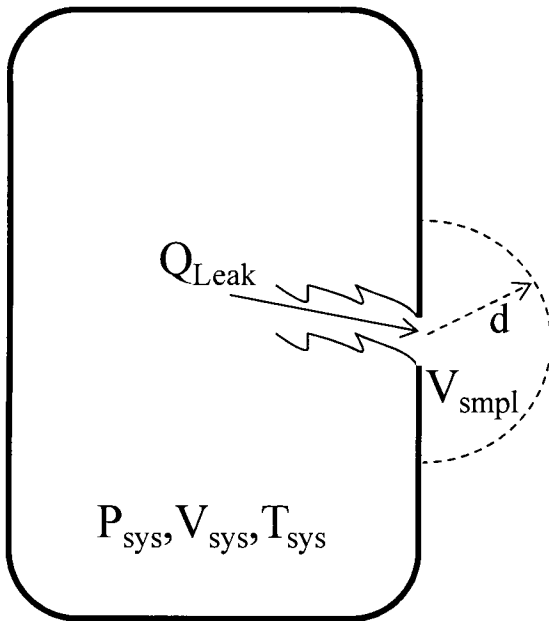

$$Q_{Leak} = \frac{dn}{dt} \approx \frac{\Delta n}{\Delta t} \approx \frac{\Delta(P \cdot V)}{RT\Delta t} \quad (31.2.1)$$

$$V_{Smpl} = \frac{1}{2} \left(\frac{4}{3} \pi \cdot r^3 \right) \quad (31.2.2)$$

$$V_{Leak} = \frac{nRT}{P} \quad (31.2.3)$$

$$\Delta[Argon] = \frac{V_{Leak}}{V_{Smpl}} = \frac{n}{V_{Smpl}} \left(\frac{RT}{P} \right) \quad (31.2.4)$$

$$\Delta[Argon] = \frac{Q_{Leak} \cdot \Delta t}{V_{Smpl}} \left(\frac{RT}{P} \right) = \left(\frac{3 \cdot Q_{Leak} \cdot \Delta t}{2 \cdot \pi \cdot r^3} \right) \left(\frac{RT}{P} \right) \quad (31.2.5)$$

Figure 31.2.1 – System Leak Illustration

the time of flow; in practice, it is the timescale for which the assumptions of the model remains accurate. The maximum time is when the effects of diffusion, convection, and sample probe pumping invalidate the model, which is considered to be one second in this application.)

Now that a theoretical model has been developed for the application at hand, probably the most important question in instrumental analysis must be answered, “*Do the instrument’s capabilities coincide with the application needs?*” In this application, the leak rate was estimated to be 8×10^{-5} sccs. Assuming the sample uptake probe is 3mm from the leak source, and standard conditions for pressure and temperature (0°C , 0.1MPa, thus 1 STD·L = 4.4×10^{-2} mol), the argon concentration change would

$$\Delta[Argon] = \left(\frac{3}{2} \right) \frac{(8 \times 10^{-5} \text{ sccs})(1\text{s})}{\pi(0.3\text{cm})^3} \left(\frac{8.31 \frac{\text{cc}\cdot\text{MPa}}{\text{K}\cdot\text{mol}} \cdot 273\text{K}}{0.1\text{MPa}} \right) = 32 \frac{\text{scc}}{\text{mol}} \quad (31.2.6a)$$

$$= 32 \frac{\text{scc}}{\text{mol}} \left(\frac{4.4 \times 10^{-2} \text{ mol}}{10^3 \text{ scc}} \right) = 1400 \text{ ppm} \quad (31.2.6b)$$

be ~1400 ppm, as illustrated in Equation 31.2.6. The observation of 1400 ppm is definitely within the capabilities of most mass spectrometer configurations. However, the goal is not to demonstrate that the component leaks – rather to find the leak, fix it, and then demonstrate that the component is within

acceptable leak parameters. As stated above, the acceptable leak rate for the Star Tracker is 2×10^{-6} sccs, which is a $\Delta[\text{Ar}]$ of ~ 35 ppm using the model and equations discussed above. Assuming the argon analyzer being used has a relative precision of 1% at atmospheric argon concentrations (~ 9300 ppm), the best (1σ) concentration change that could be observed would be ~ 93 ppm, while a reasonable confidence level (3σ) concentration change would be ~ 275 ppm, both of which are inadequate for this application. However, if the ambient argon were removed, the observed leak rate can be reduced significantly, and be directly related to detection limit. For example, an instrument with a detection limit of 10 ppm, could observe a leak rate of approximately 6×10^{-7} sccs, well within the needs for this application.

A system known as PReLIS, the Portable Leak Indication System, was used for the analysis of the Star

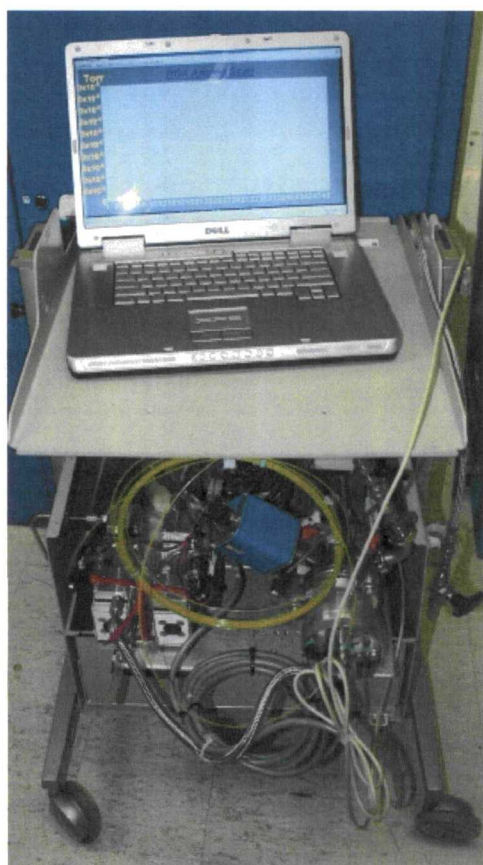
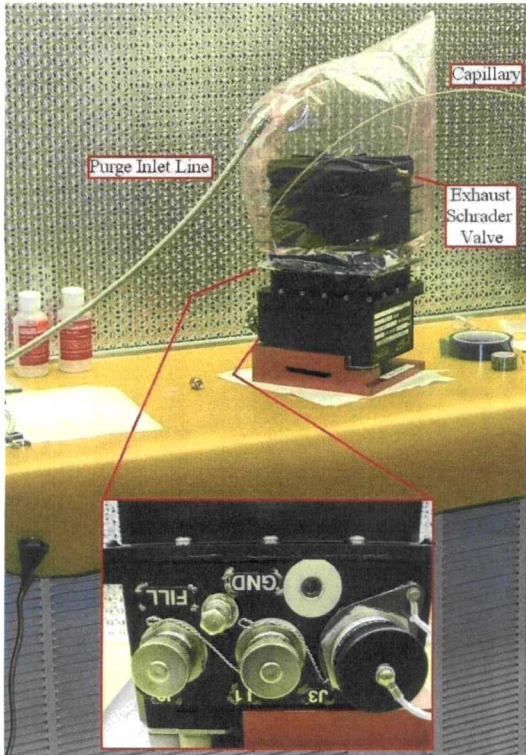

Figure 31.2.2 – PReLIS

Tracker leaks. Mounted on an oscilloscope cart, PReLIS was comprised of a Stanford Research Systems (Sunnyvale, CA) single quadrupole mass analyzer (RGA-100), a high vacuum system consisting of an Alcatel (France) ATH 30+ turbo pump and an 84.4 KNF (Trenton, NJ) 4-stage diaphragm backing pump (Figure 31.2.2). Sample acquisition was achieved by direct introduction through an 11-foot, 0.0025-inch I.D., PEEK capillary (Fisher Scientific, Pittsburgh, PA) conductance limit, which also serves as a convenient leak detection sample uptake probe. The system had a 19 – 20 sec response (transport) time as determined by breathing into the capillary intake and measuring the time required for a CO_2 response. Both vendor provided software and in-house software developed with LabVIEW (National Instruments, Austin, TX) were utilized. A short development time resulted in a software-limited

measurement rate of ~ 9 second intervals for argon and carbon dioxide. The software has since been optimized such that signal-to-noise considerations are now the measurement rate limiting factor, which was about 1 second per scan per ion monitored.

The leak detection configuration (Figure 31.2.3) had a large, transparent, electrostatic-dissipative, plastic bag placed around the Star Tracker and sealed with Kapton[®] tape (Torrance, CA.) , with only



half of the test article sealed at a time to make it easier to move the probe. A hole was cut into one corner of the plastic bag for connection to the purge inlet line, which was sealed with Kapton tape. Another small hole was cut in the bag near individual test items (valve, electrical connector or chassis seal) while testing. When each individual testing was complete, the hole was sealed with tape, and another hole was cut for the next test item. No specific exhaust hole was created since leakage through the various holes in the bag and the seal around the Star Tracker were considered adequate. Initially, the operator merely observed the raw signal of the mass spectrometer (ion current) while another operator slowly moved the probe around the test article. It soon became apparent that monitoring ion current peaks with no reference to actual

gas concentration created a tedious work condition, since not having found any leaks yet, it was difficult to quantify the progress of the leak testing. As a result, a semi-quantitative calibration of PReLIS was performed with a two-point calibration curve using the assumed atmospheric concentrations of argon (9,340 ppm) and carbon dioxide (380 ppm), along with the assumed concentrations of the purge (99.99% nitrogen and no measurable argon and CO₂ contaminants). This linear calibration method is given in Equations 31.2.7 – 31.2.9. Although this calibration method has its flaws and inaccuracies, as a metric for operators to use as a guide during leak testing it proved invaluable.

$$m = \frac{[Ar]_{air} - [Ar]_{purge}}{I_{Ar,air} - I_{Ar,purge}} = \frac{(9340 - 0)\text{ppm}}{I_{Ar,air} - I_{Ar,purge}} \tag{31.2.7}$$

$$b = [Ar]_{air} - mI_{Ar,air} \tag{31.2.8}$$

$$[Ar]_{Sample} = \frac{[Ar]_{air} - [Ar]_{purge}}{I_{Ar,air} - I_{Ar,purge}} (I_{Ar,Sample} + I_{Ar,air}) - [Ar]_{air} = \frac{I_{Ar,Sample} + I_{Ar,air}}{I_{Ar,air} - I_{Ar,purge}} \times 9340 \text{ ppm} \quad (31.2.9)$$

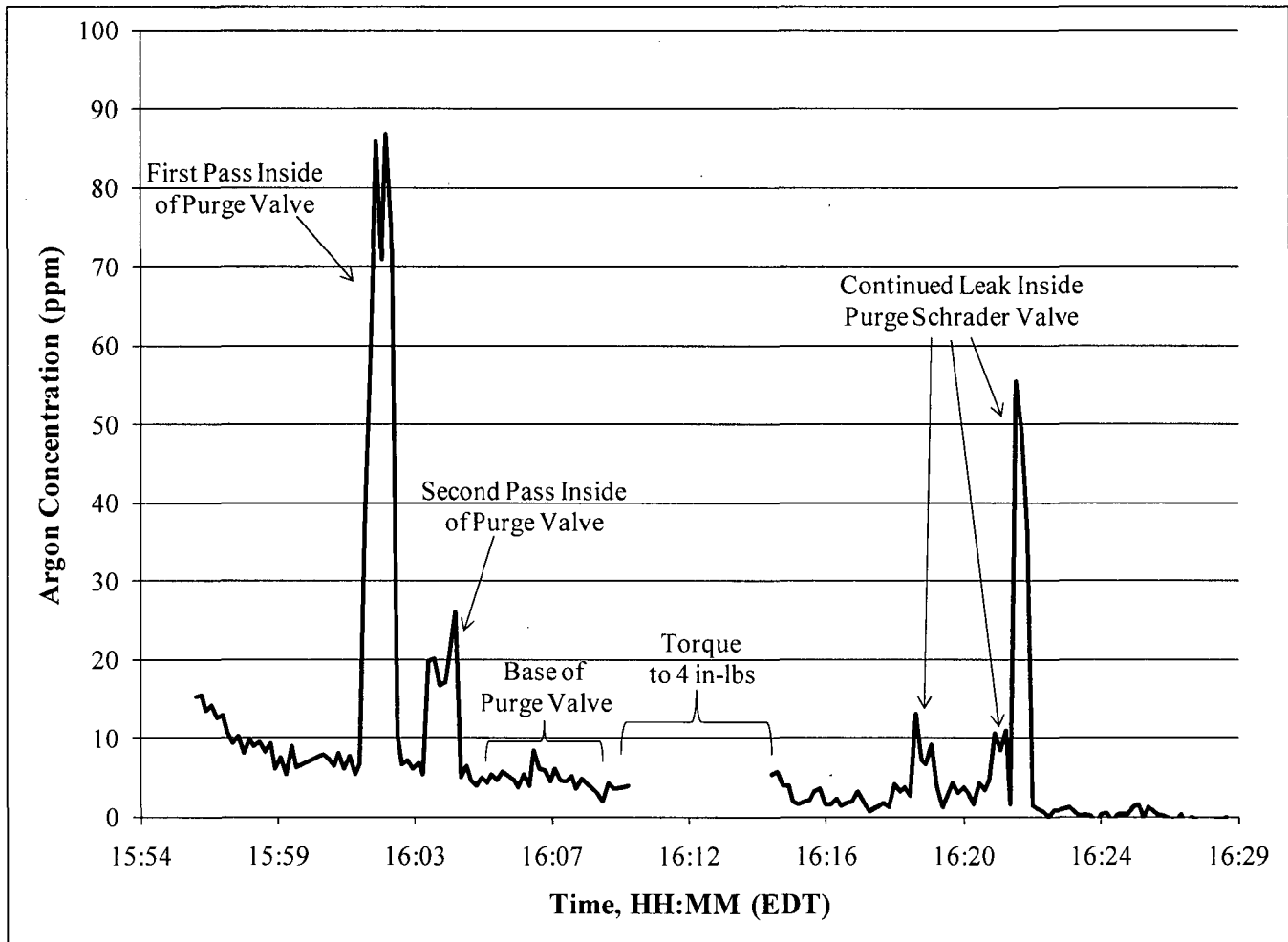

Figure 31.2.4 – This plot shows leak analysis of the Purge valve.

During leak testing, only two leak points were identified – the Fill and Purge Schrader valves. Figure 31.2.4 shows the argon single ion monitoring plot as the Purge Valve was investigated using the sample uptake probe. Notice that after the first pass of the purge valve, several features are observed. Most importantly is that the signal is much higher than the baseline, providing a high degree of confidence that a leak has been found. Next, the probe was removed from the valve for a period of time, allowing for the signal to return to baseline, then the probe sampled the valve again with similar results. The first, and least evasive, method chosen to fix the leak was to verify that the valve was installed to the proper torque level. Following this effort, leak analysis was once again performed, and it was again shown to

leak. Analysis of the Fill Valve (inset of Figure 31.2.3) gave similar results, where inside the valve produced argon peaks of nearly 30 ppm, while the base of the valve showed no leak. With this data, the decision was made to replace both Schrader valves, and subsequent testing showed no argon leaks.

The method presented here demonstrates a technique for locating leaks from pressurized components. Using a plastic bag to create an atmosphere without the leak tracer, argon in this case, a small probe was moved around the test article to identify localized leak points. A model was also presented here to assist in designing the experiment and interpreting the data. In fact the model proposed that a leak signal of nearly 1400 ppm would be expected, however the largest signal observed was an order of magnitude less. This illustrated a significant short-coming in this leak detection method. Although this method required minimal instrumentation and infrastructure and was easily implemented, it cannot account for the situation of multiple small leaks that could exceed the required leakage, nor can it certify a test article to meet an overall leak integrity. Such an application will be presented in the next section.

31.3 Real-time Leak Detection during Spacecraft Launch Activities

The Space Shuttle uses liquid hydrogen (LH2) and liquid oxygen (LOx) as propellants, which represents a flammability hazard. A nitrogen or helium purge is used to remove contaminants as well as to dilute and vent leaking vapors when loading the Shuttle with these commodities. The sampling of the controlled vent of this purge provides an excellent means to determine the leakage level of various systems during launch operations. An illustration of the primary sections of the Space Shuttle, with the purge monitoring of the Aft, Payload Bay, Mid-body and Inner Tank being the focus is shown in Figure 31.3.1.

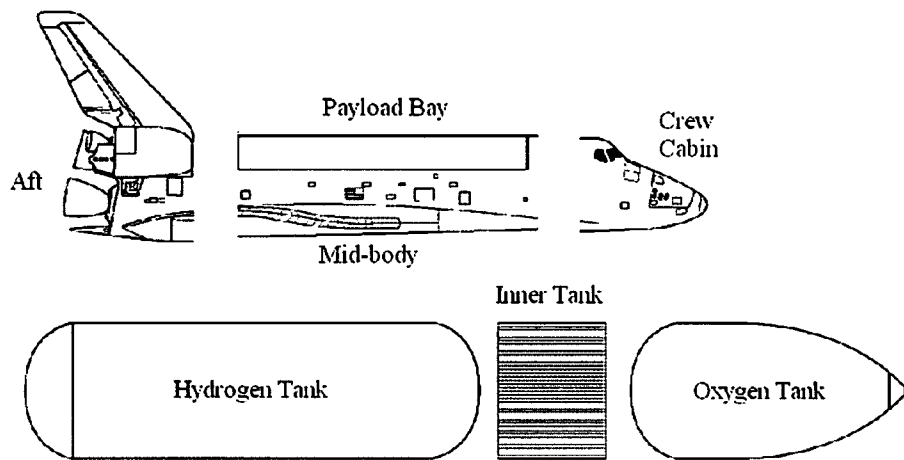

Figure 31.3.1 – Illustration of Different Purged Cavities within the Space Shuttle

A model is presented here (Figure 31.3.2) that depicts leak testing under closed / controlled conditions.

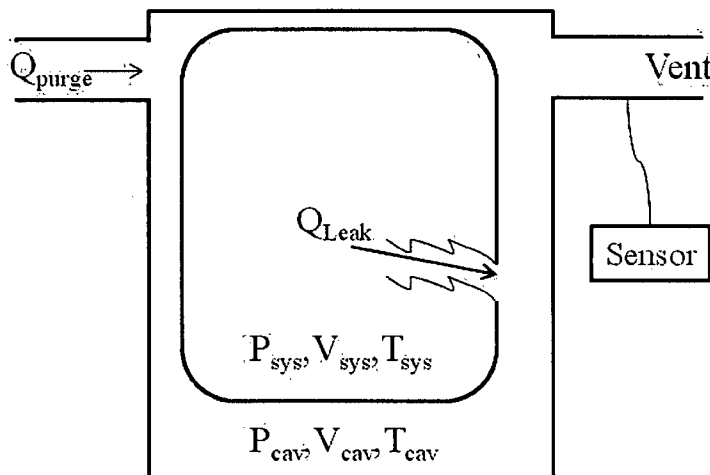

Figure 31.3.2 – Model of System Leak within Purged Cavity

This model is simpler and more accurate than that of a leak into an uncontrolled environment, since all parameters entering and exiting the system can be measured. Typically the entering (purge) flow rate (Q_{purge}), pressure and temperature are known and well controlled during an operation. As such, the calculations are given below. By definition, the measured gas

concentration (v/v) is the ratio of the gas volume contribution due to the leak and the total volume. This assumes that the purge does not contain any of the leak commodity, such as hydrogen or oxygen, which is generally accurate, but if not, the leak rate derivation is similar. Assuming the pressure and temperature of the leak gas and purge gas have equilibrated, which is usually accurate at the point of

$$[Gas] = \frac{V_{Leak}}{V_{Purge} + V_{Leak}} = \frac{n_{Leak}}{n_{Purge} + n_{Leak}} = \frac{Q_{Leak}}{Q_{Purge} + Q_{Leak}} \quad (31.3.1)$$

$$Q_{Leak} = [Gas](Q_{Purge} + Q_{Leak}) \quad (31.3.2)$$

$$Q_{Leak} = \frac{[Gas] \cdot Q_{Purge}}{1 - [Gas]} \quad (31.3.3)$$

analysis, the volume ratio is equal to the molar ratio. Assuming a homogeneous mixture, the molar flux (flow rate) ratio is equal to the molar ratio. These are described in Equation 31.3.1. Rearrangement yields Equations 31.3.2 and 31.3.3, allowing calculation of the leak rate.

An example of a purged cavity at unacceptable leakage conditions, due to flammability hazard and loss of commodity, is with a measured purge rate of 3900 scfm (110,454 sLpm) and a hydrogen leak rate

$$[H_2] = \frac{Q_{Leak}}{Q_{Purge} + Q_{Leak}} = \frac{2.34 \text{ scfm}}{3900 \text{ scfm} + 2.34 \text{ scfm}} = 6 \times 10^{-4} = 600 \text{ ppm} \quad (31.3.4)$$

of 2.34 scfm (66.3 sLpm). Using the equations given above, the resulting hydrogen concentration would be about 600 ppm (Equation 31.3.4). Monitoring for concentrations in this realm are somewhat commonplace, however, notice that a 25ppm signal (near the detection limit) represents a leak rate of

$$Q_{Leak} = \frac{[H_2] \cdot Q_{Purge}}{1 - [H_2]} = \frac{[25 \times 10^{-6}] \cdot 3900 \text{ scfm}}{1 - [25 \times 10^{-6}]} = 9.75 \times 10^{-2} \text{ scfm} \quad (31.3.5)$$

0.0975 scfm (2.76 sLpm), which is still a sizable leak when one considers that launch processing can last up to 12 hours and some commodities, such as fuel cells, have minimal cryogenic tank capacity that must last several days.

For purge gas, leak monitoring during Shuttle launch operations, a mass spectrometer-based leak detection system known as the Hazardous Gas Detection System 2000 (HGDS 2k) was developed [31.3.1]. The primary reason a mass spectrometer was chosen for this application is its excellent

detection limits, accuracy over a wide dynamic range, and the capability to monitor and differentiate several species. Mass spectrometers are also unique in their ability to measure trace to bulk levels of helium in a multi-component system. With detection limits in the 10 ppm range and nearly 5 orders of dynamic range, the system can monitor a variety of launch operations including propellant (liquid hydrogen and liquid oxygen) fill, propellant vent, propellant drain, fuel cell load and several pressurized gas (nitrogen and helium) operations. However, due to the delicacy of the mass spectrometer relative to the vibrational and acoustic stresses of launch, the system was ruggedized in a 24-inch component rack and located inside an environmentally controlled area

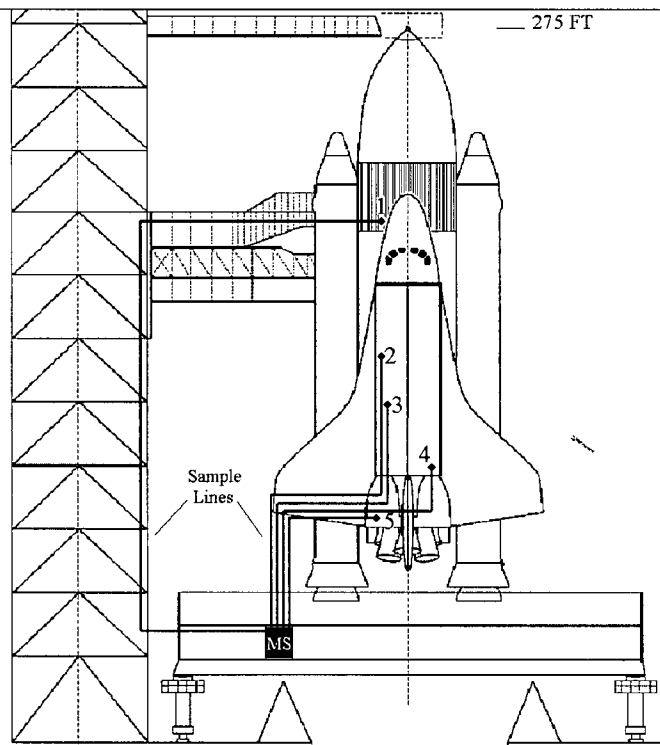

Figure 31.3.3 – Purged Cavity Sample Lines and HGDS 2k System

of the Mobile Launcher. Unfortunately, this mandates the use of several long distance, vacuum, sample transport lines (up to approximately 115 m [370 ft]), which due to the distance and flow rate, results in 15 to 30 second transport times. Samples of purge gas are taken from various locations in and around the Space Shuttle during propellant loading operations, prior to launch, as illustrated in Figure 31.3.3.

The HGDS 2k (Figure 31.3.4) consists of three racks of equipment and is installed into a Mobile Launcher where it is attached to 8 shared, continuously-pumped, sample lines; 7 shared, auxiliary, round-robin, sample lines and a redundant set of 12 calibration lines. The middle rack is a shared gas

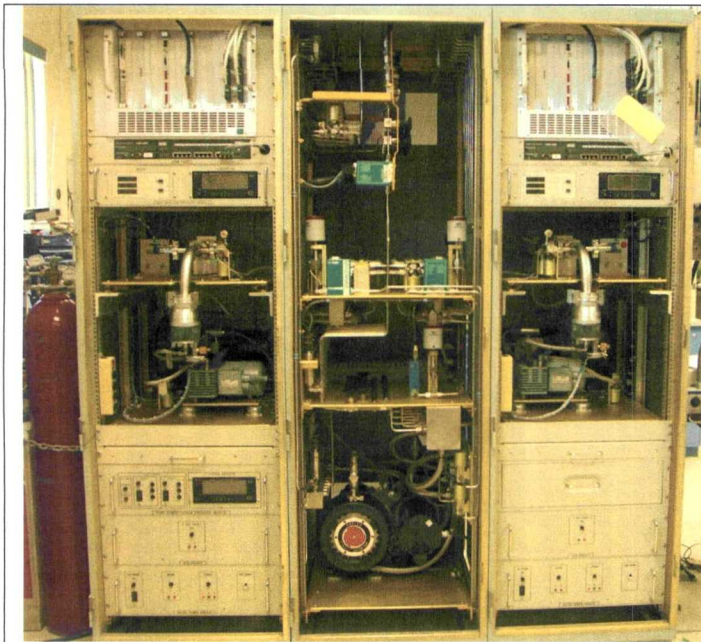

Figure 31.3.4 – Photo of HGDS 2k prior to installation in Mobile Launcher

transport system whereby samples are drawn by oil-free, vacuum pumps to deliver gas samples to the active, pressure-controlled inlets of two independent mass analyzers. The two outer racks house redundant computer controlled mass analysis detection systems, each capable of monitoring gases in helium, nitrogen, or air backgrounds. Each mass spectrometer enables near-simultaneous (within 2 to 8 seconds) monitoring of all gas constituents of interest, achieves detection limits in the 10 to 25 ppm range, maintains 10% accuracy over 5 orders of dynamic range; all with an internal system response time of less than 10 seconds.

The mass spectrometer is based on a low cost, open-source, linear quadrupole [31.3.2] residual gas analyzer from Stanford Research Systems (Sunnyvale, CA). Both Faraday cup and electron multiplier detectors are available, although the multiplier was used here. The mass analyzer generally operates in single ion monitoring mode, with the typical configuration monitoring hydrogen, helium, nitrogen, oxygen, and argon at mass-to-charge ratios of 2, 4, 28, 32 and 40, respectively. An Alcatel 31+ turbomolecular-drag high-vacuum pump was utilized for its ability to operate in high oxygen and water environments along with the need to monitor hydrogen and high levels of helium. The Alcatel model was chosen due to its high compression ratio (10^5 , 10^7 , and 10^{11} , for H_2 , He and N_2 , respectively), which allows for improved response and recovery times relative to other high vacuum pumps. For this application, the system operates best when the analyzer is in the low- 10^{-5} torr pressure range.

To complement the two independent analyzers of the HGDS 2k system, a separate set of NIST certified [31.3.3] calibration gas mixtures are installed on each side of the sample transport system. These calibration gases are plumbed directly into the sample system, such that an operator can switch (local or remotely) from a sample line to a calibration line at any time. The calibration gases serve two purposes. The primary function of the calibration gases is to provide a means to generate a calibration curve for

the system so that in real time an operator can have data provided in terms of raw response (pico-amperes in this case), or in terms of relative concentration, such as parts-per-million. The secondary function of the calibration gases is to serve as an immediate comparison when an event of concern occurs. Such a comparison provides good evidence that HGDS 2k is functioning properly and that an event has occurred. This reduces the high rate of false readings that plague so many harsh environment sensors. In fact this method of comparison, and the excellent observation skills of the operators, was successfully used to identify a false negative event during launch processing [31.3.4].

Two types of computers control HGDS 2k - local and remote. The local computer controls all hardware functions and interfaces to the remote computers. The remote computers provide user interfaces and most data logging. The local system is a VME platform computer that interfaces with all hardware systems via serial RS-232 communications. These systems include the RGA, turbo pump, pressure transducers, flow meters, and flow controllers. Analog and digital inputs and outputs also communicate via RS-232 across an OPTO-22 (Optomux) bus. The local computer system is part of the redundant outer racks comprising HGDS 2k. The local system interfaces with up to eight remote computers via a fully redundant Ethernet 100 BaseT. All data is time-tagged locally using an IRIG module within the VME chassis. The remote personal computers use a Microsoft operating system with user interface software written in C++. The software enables the user to input all commands and to monitor the health and the status of the system. All calibration, tuning, and gas concentration monitoring is performed by sub routines, or windows, written specifically for the task. The interface is considered intuitive and easy to operate, thus allowing engineers from various backgrounds to learn the system with minimal training. The software has been revised several times to provide additional operational features such as scripting and improved data visualization and analysis capabilities.

Three NIST traceable (secondary standards) calibration gas bottles [31.3.3] designated Low (99.9999+% N₂), Test (500 ppm H₂, 500 ppm He, 500 ppm O₂, 100 ppm Ar, and balance N₂, nominally), and Span (5000 ppm H₂, 5000 ppm He, 5000 ppm O₂, 1000 ppm Ar, and balance N₂, nominally) were analyzed sequentially for total duration of about 7 minutes. Each gas bottle is selected for 60 seconds to allow the system to equilibrate, then 10 data points are collected, at which time the next bottle is selected. This constitutes the calibration cycle, where data from all three bottles are used to determine a three-point least-squares calibration curve and the test bottle also is used to assess the quality of the calibration.

Using the 10 data point, averaged measured ion response for the gases of interest for the Low gas (X_L), Test gas (X_T) and Span gas (X_S), and the certified calibration bottle concentrations for the Low gas (C_L), Test gas (C_T) and Span gas (C_S), the sensitivity coefficient (m) and offset (b) are calculated using

$$m = \frac{3(X_L C_L + X_T C_T + X_S C_S) - (X_L + X_T + X_S)(C_L + C_T + C_S)}{3(X_L^2 + X_T^2 + X_S^2) - (X_L + X_T + X_S)^2} \quad (31.3.6)$$

$$b = \frac{1}{3}(C_Z + C_L + C_S) - \frac{m}{3}(X_Z + X_L + X_S) \quad (31.3.7)$$

Equations 31.3.6 and 31.3.7, respectively. To obtain a measure of the quality of the calibration, a calibration error is calculated by determining the relative error between the measured Test gas concentrations, using the calibration curve, and that given by NIST analysis (Equation 31.3.8). A relative accuracy of 10% is considered acceptable for this application. Once the calibration has been

$$\%Error = \frac{(mX_T + b) - C_T}{C_T} \times 100\% \quad (31.3.8)$$

completed, and the accuracy requirements are met, the Equation 31.3.9 is used to calculate the concentration of the sample (C_{smpl}) using the sensitivity coefficient (m), offset (b) and the measured sample response (X_{smpl}). It is interesting to note that when operating this system near the detection

$$C_{\text{smpl}} = m \cdot X_{\text{smpl}} + b \quad (31.3.9)$$

limits, a 3-point calibration actually provides $\pm 10\%$ analysis accuracy over a broader concentration range when compared to using 4 or 5 point linear regression calibration curves.

Although an accuracy requirement of 10% may seem trivial for many analytical techniques, it is a realistic goal for this application considering the concentration range (ppm to percent levels) and the sample type (permanent gases). The system was originally designed to maintain the 10% accuracy level for only 12 hours, however it has been demonstrated to maintain this accuracy level for several weeks when retained in an operational state.

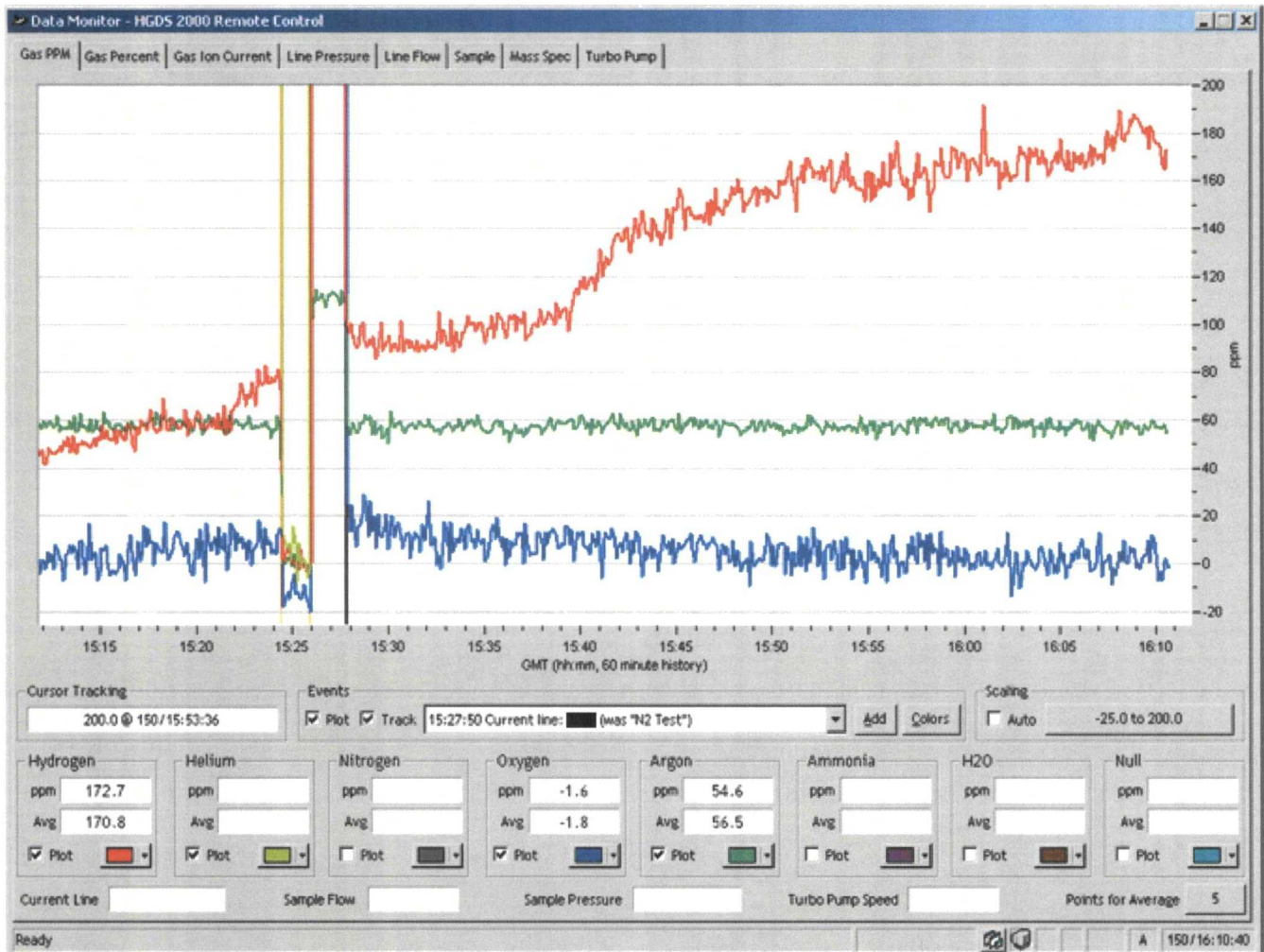

Figure 31.3.5 – Data from a nominal hydrogen leak during propellant loading for STS-111.

Data analysis was performed in real time by the software running on the remote computer. Once a calibration has been performed, the software retains the calibration parameters and converts the measured raw signal (ion current) into the calculated gas concentration. An example of one of the primary user interfaces is shown in Figure 31.3.5. The screen shot shows the historical data plot for hydrogen (top plot on right side), argon (middle plot) and oxygen (lower plot on right side). Other accessible information in data boxes or on header tabs include instantaneous gas concentrations and a variety of other system parameters such as current sample line, sample flow, and sample pressure. The window tabs can be selected to view historical data plots of the raw, ion current data as well as a wealth of health and status data. Notice that the screen shot also shows when the calibration gas was activated (~15:25 GMT), as a means to both confirm that the upward hydrogen trend was accurate, but to validate the accuracy of the hydrogen data.

On several occasions, HGDS 2k has identified or verified leak conditions during launch operations that could have resulted in equipment damage, mission failure or loss of life. Mass spectrometry has proven to be an excellent technology to use for leak detection during cryogenic propellant transfer.

31.4 Post-launch Analysis of Engine Performance and Integrity

The stresses on the Space Shuttle Main Engines (SSME) during launch are of concern because of the harsh vibration and acoustics experienced by the vehicle during ascent to orbit. This is of utmost importance for the Shuttle because of the humans aboard the vehicle and the fact that the SSMEs are reused. As was discussed in earlier sections of this chapter, extensive leak checks are performed before launch. Because of the volume and safety concerns associated with liquid hydrogen and liquid oxygen propellants, testing of the engines are performed utilizing helium or other tracer gases. While the leak checks have proven to be a viable method to characterize the SSMEs, many factors keep them from being a complete picture of the SSMEs' state during launch. The two major factors that limit this method of leak detection are the inability to use liquid hydrogen or liquid oxygen and that the engines are not operating during the tests (low pressure). Therefore, it is important to have some means to determine if a major leak of the SSMEs has occurred during launch. Toward this end, a method was developed to examine the gases in the Aft Compartment during ascent.

Detecting an anomaly during launch involves monitoring the same compounds as before launch (H_2 , He, O_2 , Ar) plus new targets: CO, CO_2 , and low molecular weight hydrocarbons. The CO and CO_2 are mainly utilized to determine if the exhaust from the pyrotechnic devices on the sample bottles was pulled into the sample bottles and thus interfering with the analysis. The method that was developed involves acquiring samples during launch and analyzing them post landing, after the vehicle is back at Kennedy Space Center, FL. While the pre-launch leak tests are interested in extremely small leaks, equating to parts-per-million concentrations, these analysis are interested in larger leaks, equating to percent concentrations. However, unlike ground processing, this technique requires the analysis to be performed at multiple sub-atmospheric pressures because samples are obtained as the vehicle ascends

and the atmospheric pressure decreases. Meeting these requirements meant that not only did unique instrumentation need to be implemented but also that new sample catch bottles had to be developed.

The overall methodology for these analyses is a rather standard approach to sampling and analyzing samples. The samples are collected into sampling containers, or bottles, and transported back to the laboratory where the analysis is performed. The analysis utilizes a uniquely designed gas chromatography/mass spectrometry (GC/MS) system. Mass spectrometry was determined to be the best detection system for this application because of the need to monitor helium and other constituents that would require a large sample to feed multiple analytical techniques. Mass spectrometry is also very sensitive, needing only a small sample for analysis. Gas chromatography was utilized to separate the components from each other, thus helping to eliminate interferences that occur when MS alone is utilized. The combination of the GC and MS techniques provide two parameters (retention time and mass spectrum) to confirm component identification. This double confirmation is important because erroneous measurements could lead to very costly and/or potentially deadly mistakes during Space Shuttle processing. For example, a false positive report of a leak would lead to extensive amounts of money (millions of dollars) and launch schedule delays. However, the worse case would be a false negative report that could lead to a catastrophic leak occurring during operation and either cause an abort during the mission or the loss of the vehicle and crew.

While the sampling technique followed a relatively standard methodology small, rugged, lightweight sample, or catch, bottles had to be developed. The catch bottles have to be able to sit on the vehicle ready to support launch for a month, autonomously collect a sample, hold the sample for up to a month without degradation, withstand launch vibrations, and be light weight. The current design of the sample bottles are shown in Figure 31.4.1. These sample bottles are made out of aluminum, have two pyrotechnic plugs, a sampling port, an evacuation/monitor line, and a location for the attachment of a cold cathode gauge to monitor pressure. Before reuse the bottles are sent to the manufacturer and totally refurbished. This includes complete disassembly, reassembly, bake-out, and leak checking. In addition to the refurbishment, the bottles are evacuated to less than 1×10^{-7} Torr; they typically arrive with pressures below 1×10^{-8} Torr. Extreme care is taken to clean the bottles and ensure no contamination or residual atmospheric gases are present; this is critically important because of the low pressures of the

samples and because some of the most important components of interest are the same, or similar, to commodities naturally occurring in the atmosphere

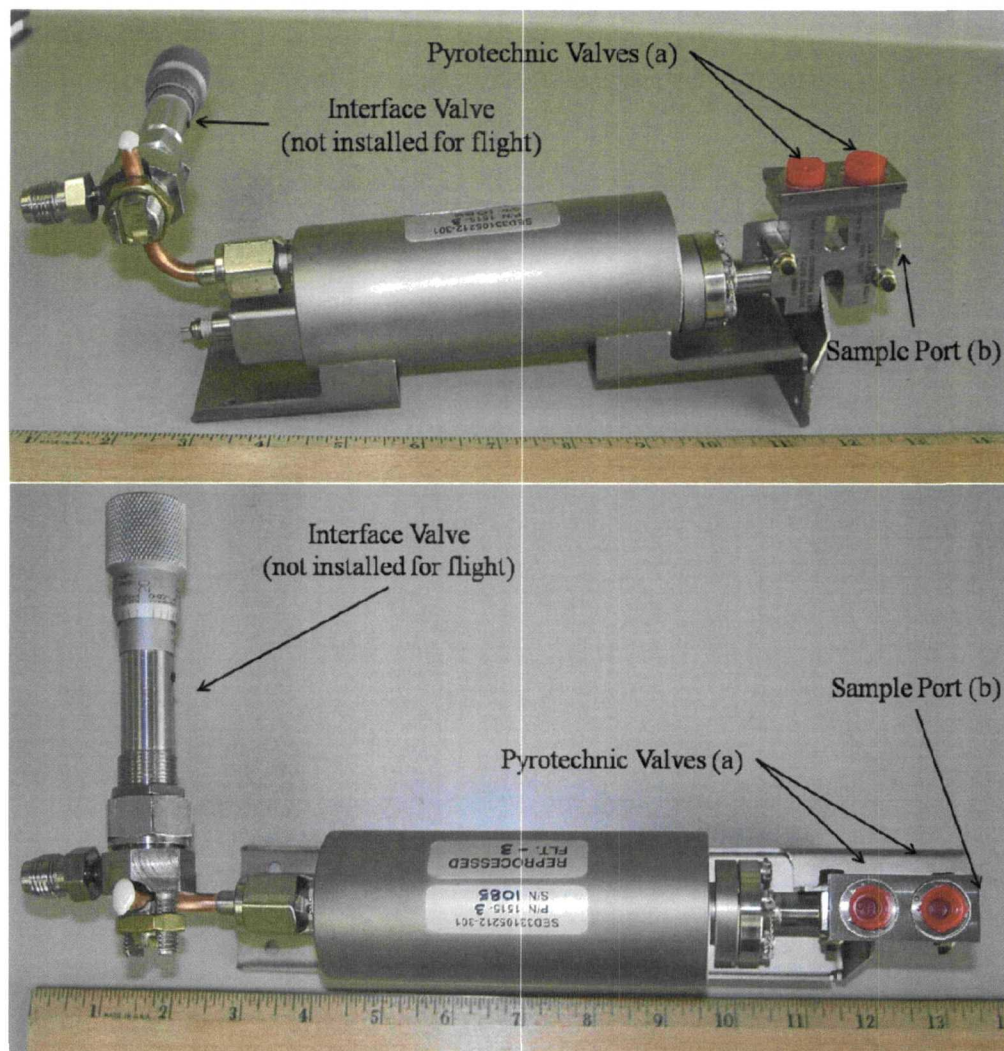

Figure 31.4.1 – Side and top views of the collection bottles; the device on the copper tubing on the left of the figure is the interface valve used to attach the unit to the GC/MS introduction system and puncture the copper tubing. The interface valve is not attached during flight. The samples are introduced into the bottles by firing of the pyrotechnic valves (a) which allows the surrounding atmosphere to enter the sample port (b). After two second the adjacent pyrotechnic valve fires (a) sealing the sample inside the collection bottle.

After refurbishment the bottles are sent to KSC to install onto the Orbiter before launch. Three sample bottles are then assembled onto mounting racks; these racks are used to mount the bottles to the Orbiter and to feed the pyrotechnic control lines to the correct locations. One rack assembly, containing three

bottles, is mounted on each side of the Aft Compartment. If the launch is scrubbed and a delay occurs for an extended period the pressures are re-verified before launch; it is not necessary to disassemble the mounting racks to measure the bottle pressures. This is accomplished via a cold cathode gauge located below the copper tubing; the magnets and high voltage leads are slipped over the gauge on the bottle.

At specific times during ascent the sample valve on a bottle is opened for one second; this is accomplished by firing one pyrotechnic valve which allows gas to enter the bottle through the sample port. The second pyrotechnic valve is fired two second after the first; closing the valve and trapping the sample inside of the bottle. After firing the pyrotechnic valves must be able to withstand the shock of re-entry, landing, and a possible ferrying flight without allowing any atmospheric gas from entering the bottle.

After landing the catch bottles are sent to the laboratory for analysis. In the laboratory the catch bottles are attached to the GC/MS via the monitor line. After the bottles are attached to the instrument the sample lines are evacuated and leak checks are performed. The gas samples are analyzed sequentially by puncturing the monitor line via the hand valve which allows the sample to enter the GC sample loop. The pressure is recorded after a stable pressure is reached and the sample is injected onto the GC for analysis. The monitor line is then reclosed via the hand valve and the GC sample line is evacuated for the next analysis. Each catch bottle is analyzed three times and the average reported.

The initial pressures of the sample bottles are calculated utilizing the ideal gas law. Where P_0 is the pressure in the catch bottle before the sample is removed, V_0 is the volume of the catch bottle, P_1 is the pressure in the catch bottle when opened to the sample line, and V_1 is the total volume of the catch bottle and sample line.

$$P_0V_0 = P_1V_1 \quad (31.4.1)$$

Rearranging gives

$$P_0 = \frac{P_1V_1}{V_0} \quad (31.4.2)$$

The pressure for the second replicate gives the following equation, knowing that the volumes do not change during the processes. Where P_1 is the pressure in the catch bottle when opened to the sample line the first time and P_2 is the pressure in the catch bottle when opened to the sample line the second time.

$$\frac{P_1}{P_2} = \frac{V_1}{V_2} \quad (31.4.3)$$

Substituting into Equation 31.4.2 gives

$$P_0 = P_1 \frac{P_1}{P_2} \quad (31.4.4)$$

This method does not require knowing the volumes of the sample lines or the catch bottles; thus allowing the modification and repair of the sample system without the need to validate or verify the sample volumes.

The samples are analyzed by a uniquely designed GC/MS to enable the monitoring of mass-to-charges (m/z) 1 to 50 amu with sample pressures ranging from 2 to 200 Torr. A one point calibration, acquired at around the same pressure as the sample, is utilized to determine the concentration of the unknown sample. The flow schematic of the GC/MS and sample introduction system is shown in Figure 31.4.2. The design allows the standard gas to be introduced from a high pressure bottle into the low pressure collector (A); this pressure is adjusted to be comparable to the expected sample pressures. To perform the analysis, the entire delivery line, including the sample loop, is evacuated by opening valve “Ext B Vacuum On/Off” and the valve “S” corresponding to the sample to be analyzed, Figure 31.4.2(a). After 10 minutes, valve “Ext B Vacuum On/Off” is closed. The Interface Valve on the bottle, Figure 31.4.1, is then used to introduce the gas into the sample loop. After the pressure stabilizes, the Interface Valve is closed. The sample is then introduced into the GC/MS via valve V-1, Figure 31.4.2(b). The GC utilizes a Carboxin column for separation of the different compounds. The Carboxin Column separates all of the compounds except for oxygen and argon and this highlights the advantage of a mass spectrometer detection system over other detection methods: to deconvolute this type of GC coelution.

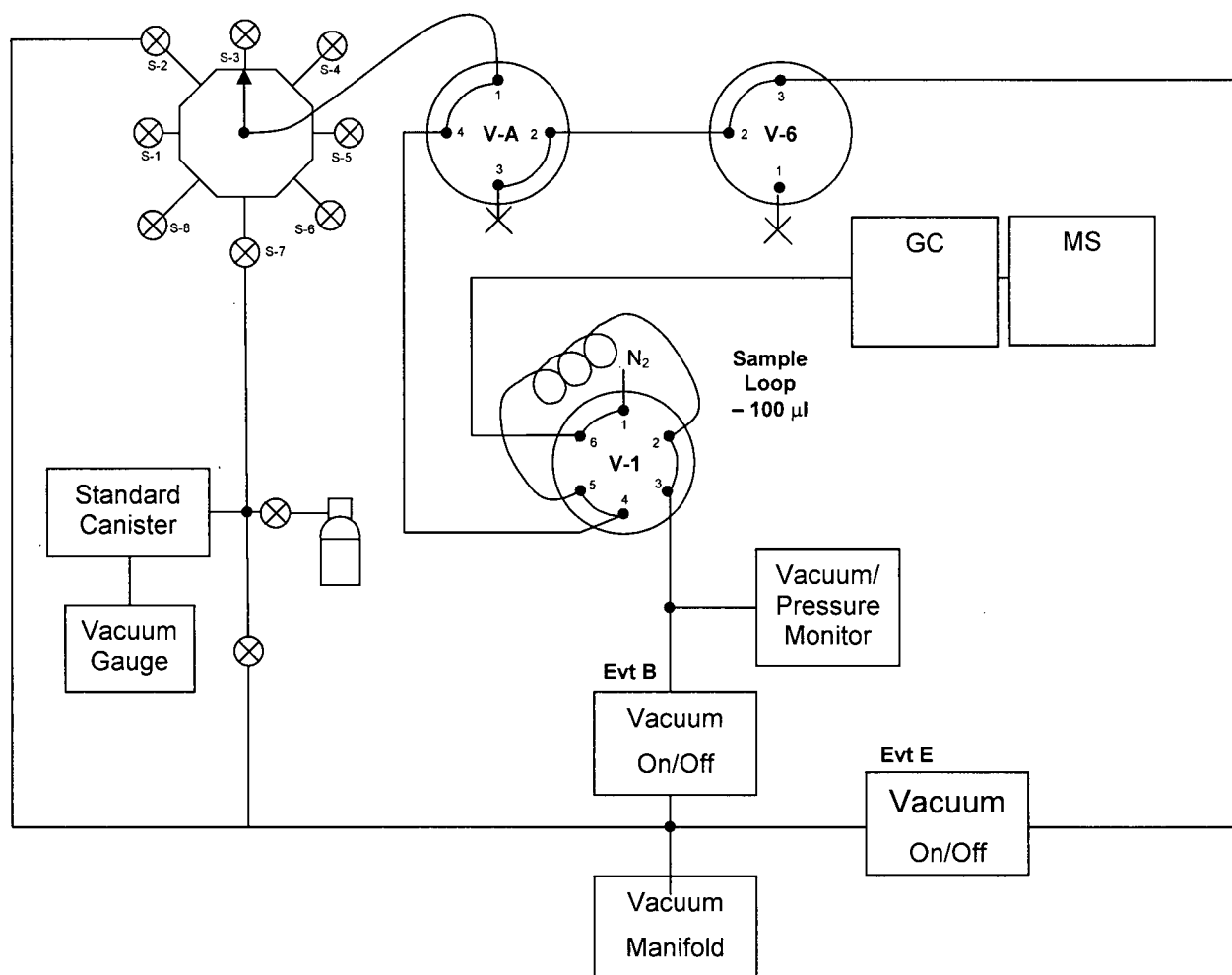

Figure 31.4.2(a). Flow diagram that depicts filling the 100 μ L sample loop from the collection bottle attached to inlet S-3.

The resulting chromatograms, acquired during analysis, are then automatically processed to determine the peak height of the compound of interest utilizing the Varian MS Workstation Version 6.4.1 Software and this information is saved as an ASCII file. These ASCII files are processed with a LabView program, written in-house, that calculates the unknown concentrations and then writes the data to a table that is imported directly to the final report. This method removes the need for repetitive operator steps, which eliminates typographical errors. After the data table is produced the data is reviewed to check the validity of the data; to determine if any points are outliers or have large standard deviations. This step is useful to determine if any particular point needs closer examination. Even though the data analysis is performed automatically, a skilled knowledgeable operator is needed to review the data. Once the data is collated and reported it is sent to the modeling group to for further analysis. The data is used to

measurements were obtained during these programs to verify crew health and inflight performance; detailed medical investigations were relegated mostly to postflight evaluations. [31.5.1] The trend of limited medical studies on orbit continued through the Apollo program with collected medical data concentrated on understanding the physiological responses that would have the greatest impact on crew health and safety.

Data from groundbased bedrest studies, which simulated living in a microgravity environment, showed a decrease in work performance. [31.5.2-5] Supporting the bedrest study trends, it was found in the Apollo program that most astronauts had a reduced tolerance for exercise during a period of hours after landing. [31.5.6] This effect was not observed during the Gemini program, because the post-flight assessment occurred ~24hrs after landing; by which time the astronaut had readapted to Earth's gravity. In the mid-1960s, NASA recognized the need to perform extensive on-orbit medical investigations to accommodate longer stays in space if exploration was to continue. Skylab (originally the Apollo Applications Program) was the logical follow-on to the Apollo program. The Skylab medical experiments included cardiovascular, musculoskeletal, hematological, vestibular, metabolic, and endocrine investigations. [31.5.7] The work begun on Skylab has continued on the Shuttle's Spacelabs, Shuttle-Mir, and ISS. This section will focus on the mass spectrometers used for metabolic studies on Skylab, Shuttle and ISS.

The performance decrements observed in the Apollo program were reversible within a day or two, but the possibility existed that longer durations in space might lengthen the recovery time or produce an irreversible effect. Therefore, the M-171 metabolic experiments [31.5.8] became a key investigation in to whether humans could adapt and work for long periods of time in a space environment. The primary goal of these experiments was to determine if the decrement in performance progressed with increasing length of microgravity exposure and what effect, if any, on orbit exercise might play in mitigating the reduced performance. A secondary goal was to test the bicycle ergometer as a personal exerciser. The equipment suite for M-171 contained the first mass spectrometer to be used on a manned spacecraft. This mass spectrometer was the metabolic gas analyzer system (MGAS), which measured the gases in the exhaled breath. This information was used to derive the crew's level of performance when exercising.

Metabolic experiments continued during the Shuttle program, where the emphasis turned to defining the most effective countermeasures to combat the temporary performance degradation on an astronaut's return to Earth. Most experiments were performed on the Extended Duration Orbiter (EDO) missions, which as the name implies, lengthened nominal Shuttle missions from 5 days to as much as 16 days. [31.5.9] Objectives of experiments were to assess the effect of different types of exercise, the intensity of the exercise, and the timing of the exercise (i.e., intense exercise near the mission's end). Although many of the Shuttle experiments used only preflight and postflight data [31.5.10] a modified version of the Skylab mass spectrometer (Gas Analyzer Mass Spectrometer-GAMS [31.5.11] and later a new quadrupole mass spectrometer (Gas Analyzer System for Metabolic Analysis Physiology-GASMAP [31.5.12] were used in some investigations.

Similar experiments to those performed on Shuttle [31.5.13 and 31.5.14] occurred during the Shuttle-Mir missions [31.5.15], but with the launch of ISS, it became possible to conduct more extensive studies, because the metabolic experiment's equipment suite was included in the permanent Human Research Facility (HRF) rack. [31.5.16] The GASMAP from the Shuttle missions was used in the ISS experiments, which performed periodic assessment of crew aerobic capacity by analyzing human metabolics, cardiac output, lung diffusing capacity, lung volume, pulmonary function and nitrogen washout. Additionally, another set of experiments examined the effect of long-term exposure to microgravity and extravehicular activity (EVA) on pulmonary function by studying crewmembers before and after an EVA. Combined, these experiments examined whether pulmonary function was affected by long-term exposure to noxious gases or to particulate matter that may accumulate in the atmosphere of ISS. [31.5.17]

The MGAS and GAMS were derived from the Perkin-Elmer two-gas analyzer design developed for Langley Research Center [31.5.18] The mass range, and hence the number of target compounds, was increased from 50 amu in the MGAS unit to 120 amu for the GAMS. [31.5.19] The Skylab experiments required detection of low molecular weight compounds at high concentrations (% level). The final version was a single-focusing 90° magnetic sector mass spectrometer, which used a metal sintered molecular leak to sample gases and dual heated filaments as the ionization source. [31.5.20] Ion collectors produced signals for oxygen, nitrogen, carbon dioxide, which were converted (details in section 31.7) to currents, then summed and compared to total pressure (Figure 31.5.1). An internal ion

pump maintained vacuum with a sealed gas analyzer assembly. Computation for deriving the data was performed onboard by the MGAS' analog computer.

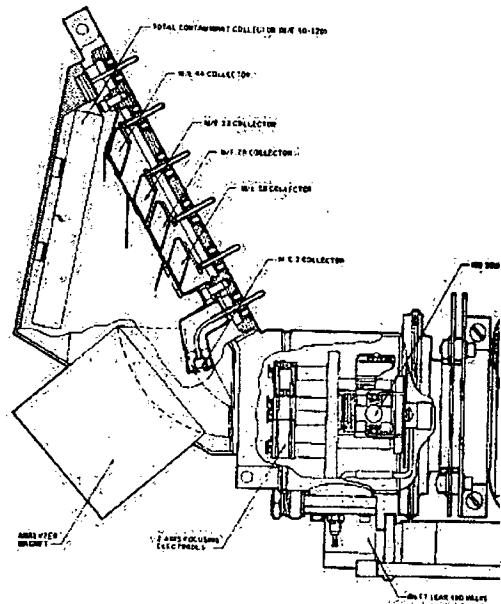

Figure 31.5.1: MGAS mass spectrometer

Measurement accuracy (Table 31.5.1) was maintained through the use of a hand pump and pressurized canisters of known gas mixtures. Calibrations were performed prior to launch, during the activation of the Skylab laboratory on orbit, and at the beginning of each Skylab mission. Results from the calibrations showed that the MGAS remained stable throughout the entire Skylab program. The gases of primary interest for the exercise decrement studies were oxygen and carbon dioxide from which, along with other measurements the metabolic pulmonary function was derived.

Table 31.5.1 – MGAS Accuracy Requirements

Target Component	Maximum Partial Pressure (Torr)	Accuracy (%FS)
Nitrogen (N ₂)	660	
Oxygen (O ₂)	330	2
Water (H ₂ O)	33	5
Carbon Dioxide (CO ₂)	23.1	3
Hydrogen (H ₂)	3.3	20

Maximum total pressure: 800 torr

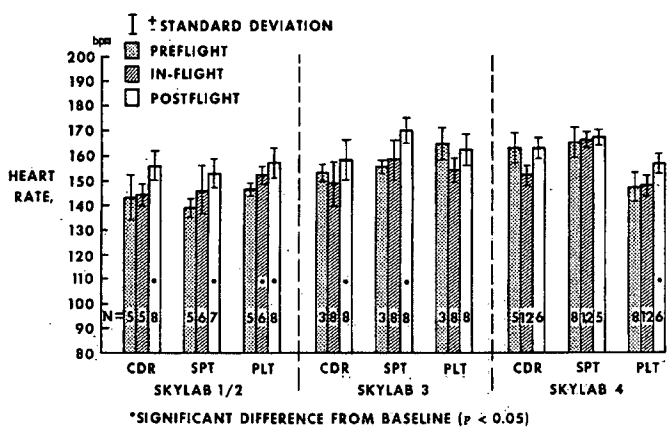

Figure 31.5.2 – Heart Rate

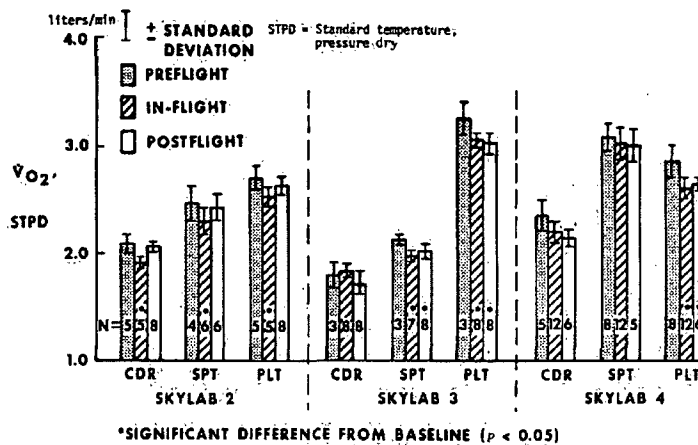

Figure 31.5.3 – Oxygen consumption

The aerobic capacity of each crewman was determined approximately 12 and 6 months before their mission, and based on this data the an inflight protocol was derived for each crewman. The protocol required data acquisition during specified exercise periods (25-75% of maximum oxygen uptake- V_{O_2}) and during rest. [31.5.21] This experiment was conducted approximately every 4 to 6 days on orbit. The results for the three Skylab missions (Skylab 2: 28 days, Skylab 3: 59 days, and Skylab 4: 84 days) are shown in Figures 31.5.2 and 31.5.3. Combined, these graphs show a postflight decrement in response to exercise as indicated by the decreased oxygen pulse (increased heart rate for the oxygen consumption). Experimental data showed that all Skylab crewmen experienced a significant postflight decrement in submaximal exercise response. The Skylab 2 crewmembers, who exercised less than Skylab 3 or 4 took 18 to 21 days to readapt. However, the crewmember from Skylab 4, who exercised the most, only required 4 days to recover. This experiment demonstrated that there was a direct correlation between extensive exercise on orbit and a short recovery time when returned to Earth. Length of stay in microgravity was not a factor in readaption time, if exercise countermeasures are employed.

The GAMS unit (Figure 31.5.4 and 31.5.5) used the same basic configuration as the MGAS, but with several design improvements, including the extension of the mass range 120 amu. The GAMS also increased the number of compounds measured to nine (nitrogen, oxygen, carbon dioxide, water vapor, isotopic carbon monoxide, nitrous oxide, argon, helium, acetylene, and total hydrocarbons (m/e 50-120). These changes were required as the investigations expanded to more detailed metabolic studies.

Marquette Electronics was marketing a quadrupole mass spectrometer in the 1980s for measuring anesthesia in hospital operating rooms. NASA's medical personnel working on new metabolic experiments were aware of the instrument and it was logical that they would pursue the enhanced capability of this instrument.

The GASMAP flight hardware (Figure 31.5.7 and 31.5.8) consisted of two components: an analyzer module and a calibration module. [31.5.23 and 31.5.24] The analyzer module contains all GASMAP's sensor and electronic hardware used to measure and analyze the inhaled and exhaled breath stream of Space Station crew members. The major sub-assemblies of the analyzer module are the Random Access Mass Spectrometer (RAMS), the Roughing pump system, the Gas Delivery System (GDS), and the Interface Shell (IS) computer. The module can be controlled via the keypad and liquid crystal display (LCD) of the front panel or a laptop computer.

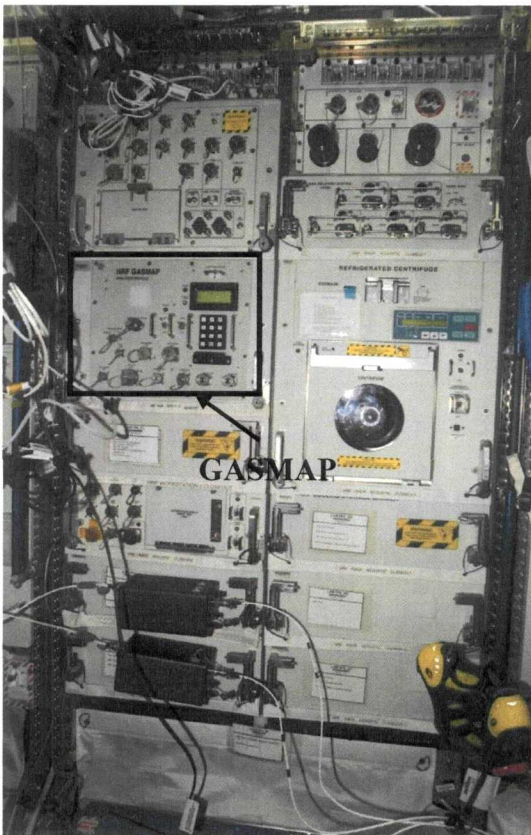

Figure 31.5.7 – GASMAP on orbit

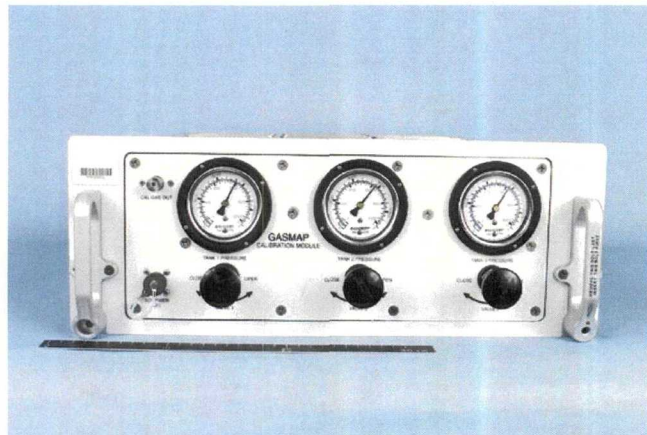

Figure 31.5.8 – GASMAP calibrant module

The Random Access Mass Spectrometer (RAMS) is the largest assembly of the analyzer module and it extends the GASMAP's mass range to 250 amu with a resolution of 1 amu and detection down to 250 ppm. The RAMS computer calculates gas concentrations and displays them on the front panel of the GASMAP, plus it prepares a second signal for data down link by the Interface Shell computer.

A gas inlet valve controls the inlet of small amounts of gas into the ionization chamber (in the range of microliters), independent from the outside pressure. The GDS provides constant gas sample flow rates in the range of 10 to 150 ccm to the RAMS for analysis. The system contains a micron screen to protect the analyzer from debris and liquid and a surge chamber, incorporated just prior to the RAMS inlet valve, to eliminate pulsation effects.

The calibration module consisted of three cylinders, filled with known gas mixtures (Table 31.5.3), that enabled the operator to compare the readings of the GASMAP system and adjust them if necessary.

Table 31.5.3 – Composition of high pressure calibration gas cylinders

Calibration Gas	Gas Cylinder Composition (%)		
	Cylinder 1	Cylinder 2	Cylinder 3
Nitrogen	80	–	10
Oxygen	20	84	62
Carbon Dioxide	–	15	5
Argon	–	1	10
Helium	–	–	10
Acetylene	–	–	0.7
Sulfur hexafluoride	–	–	2
Carbon Monoxide	–	–	0.3

None of these gases presented a safety hazard if they leak into the cabin. A Random Access Mass Spectrometer allowed the gas mixtures from the Calibration Module into the Analyzer Module for gas analysis. Additionally, the crew members set up and activated the GASMAP hardware and perform brief health checks of the equipment every 30 days to maintain high internal vacuum—in other words, to make sure the unit remained empty and uncontaminated.

An example of an ISS experiment utilizing the GASMAP was the Pulmonary Function in Flight (PuFF) investigation. [31.5.25] PuFF was designed to examine the effect of long-term exposure to microgravity and EVA on pulmonary function by studying crewmembers before and after they performed EVAs. There is a large pressure difference between the ISS habitat and the spacesuit used for EVAs. This pressure difference can lead to decompression sickness-DCS (gas bubble formation in the blood), which could alter pulmonary function and increase the risk of forming a venous embolism. A PuFF session consisted of five noninvasive tests with the crew breathing only cabin air. The tests measured the pulmonary system's ability to exchange gases, the amount of air inspired and expired as a function of time, and the maximum pressure of the air inhaled and exhaled. The analysis looked for markers indicating that the lungs had been weakened from exposure to microgravity, or that the body's ability to exchange and distribute gases had been disrupted. GASMAP was part of the instrument array used in the PuFF experiment. Although logistical constraints limited testing to the day after an EVA, the small effects observed suggested that current EVA preparation protocols are mitigating the risks from DCS. [31.5.26]

The GASMAP has also been used in joint NASA and European Space Agency (ESA) experiments spanning a wide range of respiratory and cardiovascular measurements including breath-by-breath measurements, diffusing capacity of the lungs, and numerous tests of specialized pulmonary function. [31.5.27] Additionally, significant results from GASMAP experiments have been reported for Shuttle [31.5.28) and ISS. [31.5.29]

31.6 Gas Chromatograph/Mass Spectrometry: Laboratory Operations

The gas chromatograph/mass spectrometer systems (GC/MS) at the Johnson Space Center (JSC) Toxicology laboratory generate the data used by the NASA toxicologist to determine if medical requirements have been met for the atmospheric pollutants in spacecraft. Additionally, these systems, and similar ones at White Sands Test Facility, Marshall Spaceflight Center, and at the International Partners' facilities are used for flight certification of materials and assembled hardware proposed for flight. The Toxicology laboratory also performs module offgas tests [31.6.1] as part of the certification

for new or refurbished vehicles (supply or manned) and spacecraft habitable volumes (i.e., U.S. Laboratory and Node 3). Furthermore, since the beginning of the ISS manned expeditions (Oct. 2000) the GC/MS analysis of returned air samples (grab sample containers-GSCs) has been the “gold standard” used to assess the performance of potential real-time monitors (microAnalyzer™) and to validate operational hardware (Volatile Organic Analyzer-VOA).

The comparison of the generated analytical data to the SMACs is key to the certification test approval and to the toxicologist’s assessment of air quality during a mission. What must be addressed in all of these assessments is the potential interaction between the pollutants in the atmosphere. The “t-value” calculations has been determined to be the best method of accounting for the cumulative impact of contaminants on astronauts, because scientific evidence on the effects of exposure to multiple contaminants is sparse or does not exist.[31.6.2] The t-value is the ratio of the sum of all the contaminants divided by their SMACs (Equation 31.6.1). The spacecraft’s air quality is acceptable, if the analysis of returned archival samples have a total t-value that is less than one. If the t-value exceeds one, then the NASA toxicologist must evaluate the different categories (irritant, carcinogen, etc.)

$$t \equiv \sum_{i=1}^n \frac{C_i}{SMAC_i} \quad (31.6.1)$$

separately and consider each category’s summed t-values to arrive at a conclusion about the quality of the air aboard the spacecraft. The acceptable total t-value for offgas (certification) testing is 0.5. If a SMAC has not been established for an identified pollutant, then the pollutant is assigned either a group SMAC (similar type-ketone, alkane, etc.) or a default SMAC (usually 0.1mg/m³).

The primary objective of groundbased analysis of archival samplers from spacecraft is to provide information about the air quality from a crew health and safety perspective. Additionally, these analyses supply insight into two other very important aspects of spacecraft operations: 1) was the ground-based prevention program (materials selection and offgas testing) successful in screening construction materials and 2) did the environmental control and life support systems perform nominally during the mission.

The Environmental Control and Life Support (ECLS) system moves recycled air through various scrubbers to remove contaminants that may negatively impact crew health. [31.6.3] These removed pollutants include volatile constituents at high part per million (ppm) concentrations (i.e., carbon dioxide) as well as trace contaminants at part per billion (ppb) levels (i.e., methanol). The archival sample analyses assesses the ECLS system: did the contaminant removal rate keep contaminants within established limits (Figure 31.6.1).

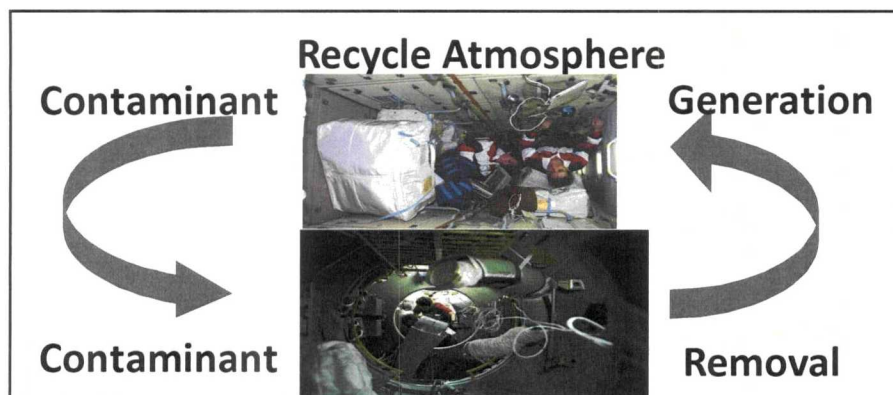

Figure 31.6.1 – ECLS goal: Contaminant removal equals Contaminant generation

ARCHIVAL SAMPLER PREPARATION

The essential steps for pre-flight preparation of archival samplers apply to both types of grab samplers (GSCs and mini-GSCs) going to ISS and Shuttle. Initial activities focus on cleaning the canisters and verifying they are clean before being put into service. An automated cleaning system (Entech) repeatedly heats and rinses canisters with humidified clean (certified zero) air. This process has been shown to effectively remove contaminants from canisters previously subjected to low ppm levels of volatile polar organic contaminants. [31.6.4] At the completion of the cleaning cycles, the canisters are once again filled with certified zero air that has been humidified (~50% relative humidity). A 200 ml (100 for mini-GSC) sample is introduced into the Automated Inlet System/Gas Chromatograph/Mass Spectrometer (AIS/GC/MS) system for analysis. A canister is considered clean if no compounds are detected above 5 ppb. Once proofed, the canister is leak checked on a vacuum rack (Pfeiffer TSU071E turbomolecular drag pumping station) to 10^{-5} torr (10^{-2} torr for mini-GSCs). The last laboratory step in the archival sampler preparation is to evacuate the canister then dose each with approximately 50 ppb of three surrogates (13 Cacetone, fluorobenzene-D5, and chlorobenzene-D5). These surrogates span the

polarity and molecular weight range of the target compounds and their analysis, upon return of the sampler to the laboratory, verifies the sample integrity. [31.6.5]

CURRENT AIS/GC/MS INSTRUMENT CONFIGURATION

The GC/MS sample analysis starts with introduction of the sample into an Entech 7100A Automatic Inlet System (AIS) via sample pump, which can acquire samples from both subambient (flight samples) to pressurized canisters (calibration standards). The AIS is comprised of a three stage concentrator, where water is removed in the first stage, carbon dioxide in the second stage, and the third stage concentrates the remaining sample in a narrow plug to enhance the subsequent gas chromatography. The first stage is a hybrid trap composed of glass beads and Tenax, where the contaminants are trapped from the sample at -150°C . This stage is heated with a flow of helium to remove water as the sample is sent to the next stage, which is a Tenax sorbent at approximately -40°C . The 2nd stage will remove most remaining water and most carbon dioxide. Nominal spacecraft samples generally contain ~ 5000 - 6000 ppm of CO_2 and $\sim 40\%$ relative humidity; however off-nominal samples can have CO_2 at $>1\%$ and humidity as high as 90% . The 2nd stage is heated to transfer the remaining sample contaminants into a passivated metal tube at about -170°C . The 3rd stage is ballistically heated so the sample is presented as a narrow “plug” to the GC column. The absorb and desorb temperatures of each preconcentrator stage can vary depending on the anticipated contaminant composition of the sample.

The gas chromatographic system is an Agilent Gas Chromatograph 6890 and the GC column is a J & W Scientific, DB-1, 150 meter x 0.25 – 0.32 mm, 1.0 – 1.4 μm thickness. New methods, using pressure control, are currently being developed to achieve satisfactory separation with a 100m column and reduce sample analysis time (now 45 minutes) as well. A typical temperature program includes a 2 minute hold at 30°C (some methods call for an initial subambient hold) and a $5^{\circ}\text{C}/\text{minute}$ ramp to 225°C .

The mass spectrometer is an Agilent mass Selective Detector (MSD) 5975 (several models), which is a quadrupole mass spectrometer with a mass range from 2-1080 amu. Agilent’s Enviroquant ChemStation is the software used to control instrument operation and to analyze the data. Typically, analyses are completed over the scan range from 23-360 at 2.3 scans/second.

INSTRUMENT PREPARATION FOR SAMPLE ANALYSIS

The procedures described in this section follow the Environmental Protection Agency's (EPA) TO-14 or TO-15 methods [31.6.6], except where noted. The EPA methods contain detailed acceptance criteria for each system check and these criteria are rigorously followed in the Toxicology laboratory.

Perfluorotributylamine (PFTBA) is used to tune and calibrate the MSD's mass scale and to establish nominal or minimal detector sensitivity (Figure 31.6.2). PFTBA tuning is typically performed following MSD cleaning and/or parts replacement, or when the daily tuning verification criteria has not been met

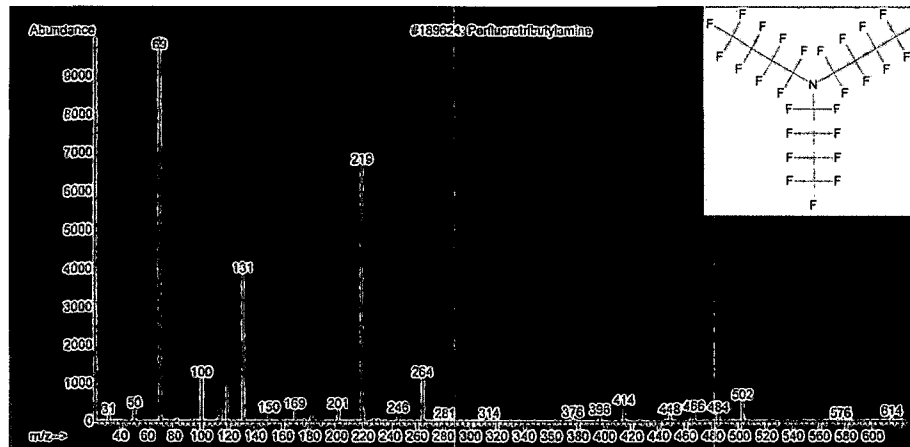

Figure 31.6.2 – Typical PFTBA mass spectrum

for Bromofluorobenzene (BFB) (see below). BFB is the EPA compound selected to standardize instrument response from laboratory to laboratory (Figure 31.6.3). Prior to the any analyses, including blanks, calibration standards, and samples, BFB is introduced into the GC/MS system, via the AIS, to

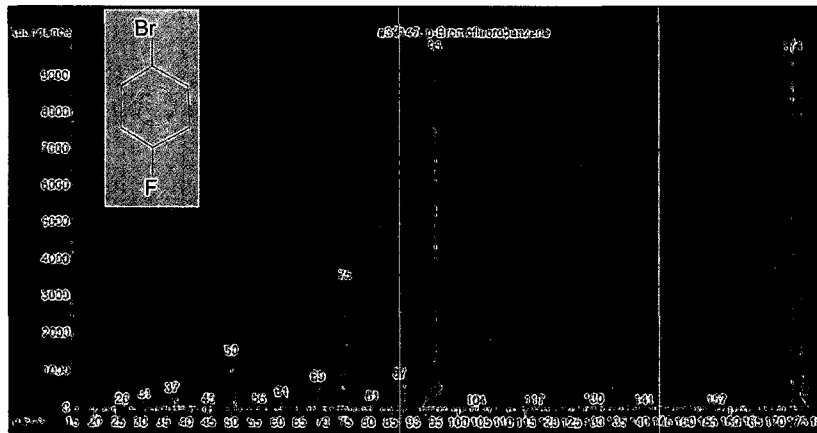

Figure 31.6.3 – Typical BFB mass spectrum. Peak ratios must be within acceptable limits verify that the mass calibration and resolution of the GC/MS are within acceptable performance criteria. The instrument performance check must be performed initially and once every 24-hour period of operation. The 24-hour time period begins with the injection of the BFB, which is the laboratory's compliance tune. Fluorobenzene (FB) is the internal standard used to monitor the absolute response of

the instrument, as well as the stability (time dependency) of the detector and the system as a whole. FB (typically 100 stdcc of 100 ppbv) is injected into every run including blanks, samples, and target standards. The area response of the base peak for the internal standard (IS) must be within ± 40 percent of the mean area response of the IS in the most recent valid calibration (Initial or Daily verification). When quantifying target and non-target analytes, the FB response is used in the calculations to normalize the instrument response from run to run. Typically, the FB response ranges from 18-40 million counts.

The prepared target standards are comprised of compounds that are observed frequently at high levels, or included because of their toxicological significance. An internal standard (FB) method of quantification is used for target compounds, but many non-target compounds are quantified using the B-value database. The target volatile organic compounds (VOCs) gas calibration standards are either purchased commercially, i.e., EPA method TO-14 standard mixture obtained from Scott Specialty Gases, or prepared in the Toxicology Laboratory from neat liquid chemicals (Tables 31.6.1 and 31.6.2). The toxic target compounds require quantification even if detected below the nominal peak area cutoff ($<10\%$ of the FB peak area). The standard calibration for the AIS/GC/MSD method requires an initial calibration comprised of single runs at 6 concentrations that cover the calibration range. The average relative response factor (RRF) is derived from this data for each target compound (Equation 31.6.2). The calculated %RSD for the RRF for each compound in the calibration table must be less than 30% with, at most, two exceptions up to a limit of 40%. The initial calibration must be performed when any major component is replaced in

Table 31.6.1 – Standard target compounds

Target Compounds (TO-14 / Polar)			
Freon-12	Butanal	2-Pentenal	1,3,5-Trimethylbenzene
Chloromethane	2-Butanone	Dichloromethane	1,2,4-Trimethylbenzene
Freon-114	Freon113	1,1,2-Trichloroethane	1,3-Dichlorobenzene
Methanol	2-Methylfuran	Toluene	1,4-Dichlorobenzene
Acetaldehyde	Ethylacetate	Hexanal	1,2-Dichlorobenzene
Vinylchloride	Hexane	Mesityloxiide	1,2,4-Trichlorobenzene
Bromomethane	Chloroform	1,2-Dibromoethane	Hexachloro-1,3-Butadiene
Ethanol	2-Butenal	Butylacetate	1,2-Dichloropropane
Chloroethane	Heptanal	Tetrachloroethene	1,1,1-Trichloroethane
Acetonitrile	n-Heptane	Chlorobenzene	Trans-1,3-Dichloroethane

Propenal	n-Butanol	Ethylbenzene	2,5-Dimethylfuran
Acetone	n-Propanol	M/P-Xylenes	2,3-Dimethylpentane
Propanal	1,4-Dioxane	2-Heptanone	4-Methyl-2-Pentanone
Isopropanol	2-Pentanone	Cyclohexanone	cis-1,3-Dichloropropen
Freon11	2-Methylhexane	Trichloroethene	3-Chloropropene
Furan	Acrylonitrile	Styrene	Carbontetrachloride
Pentanal	Benzene	1,2-Dichloroethane	1,1,2,2-Tetrachloroethane
Pentane	3-Methylhexane	O-xylene	1,1-Dichloroethane
2-Methyl-2-Propanol	Methylacetate	1,1-Dichloroethene	cis-1,2-Dichloroethane

Table 31.6.2 – Toxic target and frequent non-target compounds

Target Compounds (Toxic)	Frequent non-Target Compounds
1,3 Butadiene	Octafluoropropane**
Ethylene Oxide	Sulfurhexafluoride
Carbon Disulfide	Carbonylsulfide
2-Methyl-2-Propenal	Trimethylsilanol
3-Buten-2-one	Hexamethylcyclotrisiloxane
2-Ethoxyethanol	C10-Alkane
Dimethyldisulfide	Benzaldehyde
Octamethylcyclotetrasiloxane	C8-aldehyde
	2-Ethylhexanol
	C11-Alkane
	Limonene
	Decamethylcyclopentasiloxane

the AIS/GC/MSD system, a major parameter modification AIS/GC/MS, or a failure of the daily calibration verification (see below).

$$RRF = \frac{A_s}{A_{IS}} \left(\frac{C_{IS}}{C_s} \right) \quad (31.6.2)$$

where:

- As = area of the characteristic ion for the compound to be measured
Ais = area of the characteristic ion for the internal standard
Cis = concentration of the internal standard (ppbv)
Cs = concentration of the compound to be measured (ppbv)

Assumes the volume is the same for sample and QC sample for each analysis.

The method detection limit (MDL) is defined as the minimum concentration of a substance that can be identified and quantified following the procedures described in this section. The MDL is determined using the calculated standard deviation of the measured value at or near zero concentration of the analyte. Seven replicate AIS/GC/MSD analyses are performed at the selected concentration for each compound. For each compound, the concentration value that corresponds to the standard deviation of the seven replicate measurements multiplied by 3.14 (i.e. the Student's t-value for 99 percent confidence) is determined to be the method detection limit for the analyte. The MDLs for non-target compounds are estimated based on typical GC/MSD instrument detection limits.

A continuing check of the system, called the daily (continuing) calibration, is run prior to all sample analysis to ensure that the analytical system has not significantly changed. The daily calibration involves running standards from one concentration level, typically 100 ppbv, and comparing selected RRFs to the initial calibration. The relative response factors for the target compounds, as determined from the single-point daily standard, must lie within $\pm 30\%$ of the average relative response factors established from the initial calibration. A 100 ml sample size results in a MDL of 0.025 mg/m^3 .

System blanks are important to ensure the generation of quality data by verifying that the system is free of obvious interferences or carryover from previous sample injections. A system blank, consisting of at least 100 stdcc of humidified zero air, must be run at least once in a 24-hour analytical sequence. Additionally, blanks are run after the calibration standard(s) and before sample runs or whenever a high concentration sample is encountered (outside the calibration range). The AIS/GC/MSD system is considered clean if there is no volatile organic compound detected at a concentration greater than the established detection limits.

ARCHIVAL SAMPLE ANALYSIS

Prior to any sample analysis, the GSC's pressure is measured by a calibrated Sensotec 450D to insure sample integrity. Throughout the entire sequence of analytical runs, the GSC pressure is recorded for use in quantification calculations and to verify that a leak has not developed. Aliquots of the GSC samples are used to quantify methane, carbon monoxide, carbon dioxide, and hydrogen before a last

small aliquot is acquired to determine hydrocarbon loading. The remainder of the sample is used to obtain the VOC analysis by AIS/GC/MS. Once the AIS/GC/MS system operational readiness has been verified (see previous paragraphs), the GSC analysis begins. Sorbent tube samplers, mentioned in Section 31.1.2, begin their analysis by thermal desorption into GSCs at 240°C with a flow ultra-pure helium. Once the sorbent tube contaminants are in the GSC, the same TO-14/15 methods are used to complete the analysis.

A portion (usually 100 cc) of the GSC contents is transferred to the AIS/GC/MSD system, where the GC/MSD identifies and quantifies the target and non-target compounds following the AIS sample pretreatment. Analyses are conducted in the MS scan mode and identification is determined from GC retention time and key ions. The entire mass spectrum for a compound is not used for quantification, but rather a single ion mass (usually largest peak) is integrated to arrive at the compound's concentration. If one or more compounds are overloaded (exceed calibration curve 25-300 ppb), then the sample is rerun with at a smaller sample volume (25 or 50 cc). The new mini-GSC analysis will use a 50 cc sample, because of the sampler's smaller volume .

The data provided by the archival samplers is used by the NASA toxicologist to determine the acceptability of the air during missions. When archival samplers are not returned regularly (i.e., following the Columbia accident in 2003), then concern about crew health is heightened with each passing month because of reduced insight into the ISS atmospheric pollutants. Development of real-time monitors is one risk mitigation step for this problem. Archival sample data also provide trending information and a means to assess candidate real-time monitors flown as experiments.

Typical total ion chromatograms (TIC) from GSC analysis are shown in Figures 31.6.4 (Shuttle) and 31.6.5 (ISS). Notice that there are heavier molecular weight compounds (later in spectrum) in the ISS sample as opposed to the Shuttle sample.

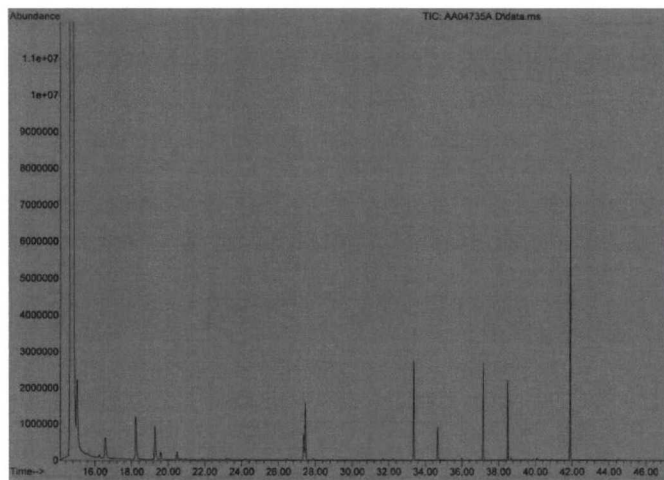

Figure 31.6.4: TIC from Shuttle GSC sample

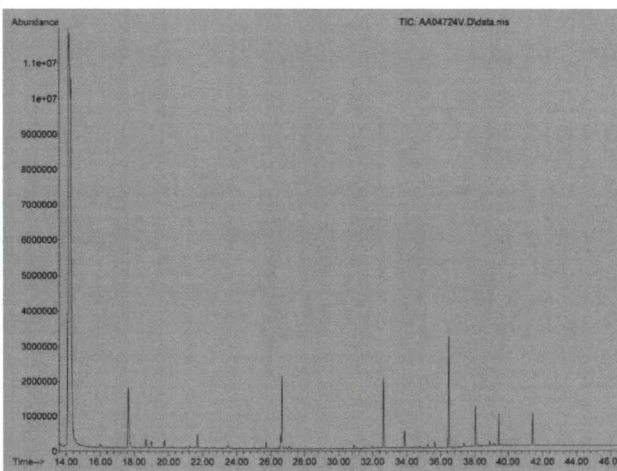
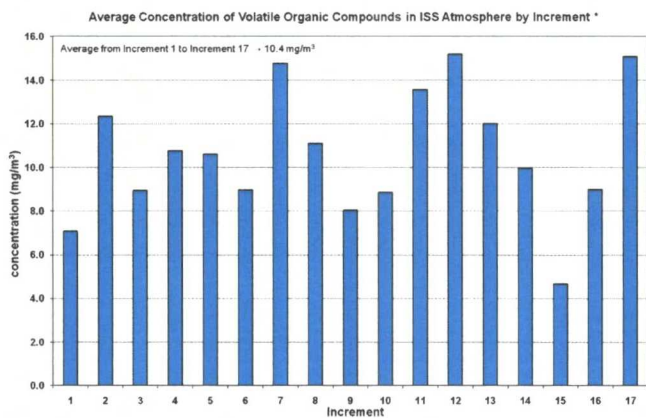
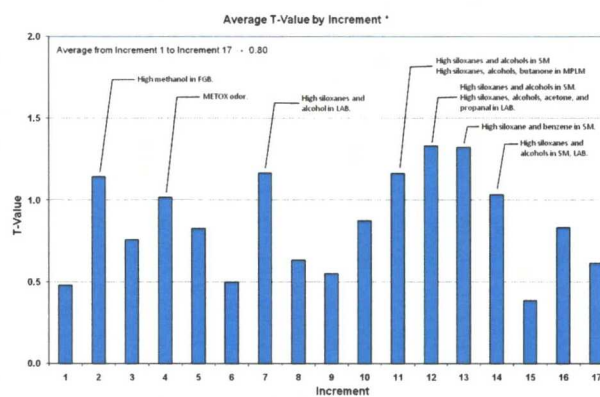

Figure 31.6.5: TIC from ISS GSC sample

In addition to use for assessing air quality for specific missions, the GSC data is also employed to track trends in ISS contaminant concentration. In Figure 31.6.6 the total VOC concentration is presented for ISS Expeditions 1-17 (10/2000-10/2008). It can be seen that the total VOCs vary over time and this can be related to the number of astronauts onboard, the ECLS system’s operational status, and the types of experiments or activities occurring during that time period. However, the total VOC loading is not the entire picture, because the average t-value for a particular expedition (Figure 31.6.7) must also be considered. Notice that in increment 2 the T-value and the total VOCs are high, which was in part due to an unknown source of methanol during a portion of the increment. On the other hand, the total VOCs is high for increment 17, but the average t-value is low for this increment. This circumstance arises because a compound with relatively low toxicity was detected in higher concentrations during this increment.



*Notes: (1) Average VOC concentrations based on US GSC archival samples only.
 (2) Average VOC concentrations do not include methane or Freon-218.



*Notes: (1) Average T-Values based on US GSC archival samples only.
 (2) Average T-Values do not include CO₂ contribution.

Figure 31.6.6 – Increment total VOCs concentrations

Figure 31.6.7 – Increment “t-value”

A few examples will show how the data is used to assess air quality on spacecraft. In the GSCs returned from the Shuttle-Mir program, a new compound appeared that had the signature of Freon, but it was not one we had previously detected in spacecraft. A mass spectrum (Figure 31.6.8) for the compound seemed to match that of perfluoropropane (F218) and a standard later confirmed the compound’s identity. The identification was complicated by coelution with other compounds and accurate quantification required trapping at -70°C on Tenax. Generally, the spacecraft air is reasonably free

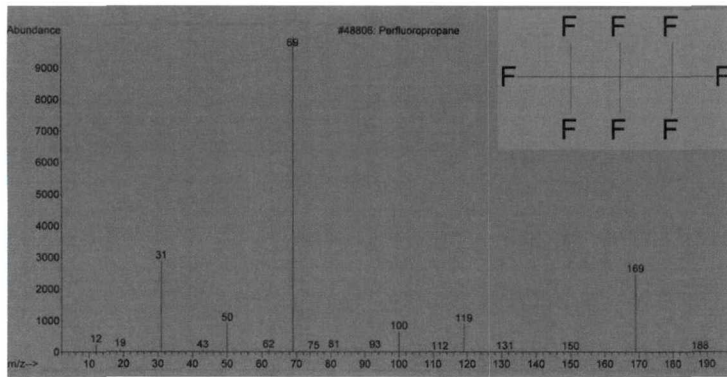

Figure 31.6.7 – Library database spectrum of Freon 218

of contaminants (see Figure 31.6.5 for ISS); however a fire during the Shuttle-Mir program aboard the Mir was a significant air quality degradation event. [31.6.7] Fortunately, immediately after the event (SFOG), the U.S. crewmember began using the Solid Sorbent Air Sampler (see section 31.1.2) to collect sorbent tube samples of the air during cleanup efforts. The analytical results from these samples are shown in Figure 31.6.9. This data shows that even 5 hrs after the event benzene was at almost

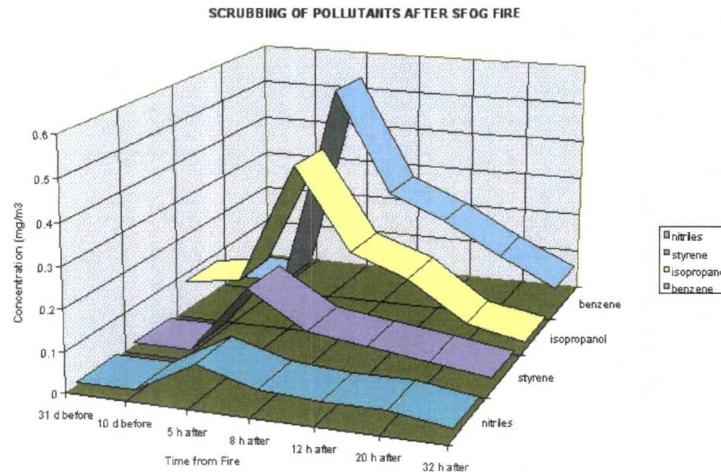

Figure 31.6.8 – Solid sorbent tube analysis of SFOG fire samples

6 times the SMAC value, but within 24 hrs of the fire, all compounds had returned to safe concentrations. Although the samples were returned and analyzed with 2 months, the crew was appreciative of the results that showed minimal exposure to harmful contaminants. These and other incidents [31.6.8] have sparked the continued progress toward real-time monitoring capability.

31.7 In-flight Environmental Use of Mass Spectrometry and Complimentary Analyses

The development of a space station, housing six people for six months or more, led to a requirement for continuous atmospheric monitoring to insure the comfort and safety of the crew. Additionally, the monitoring was to provide information on the status of the Environmental Control and Life Support (ECLS) System and track the space station “leak” rate. The initial design of Space Station Freedom included an Atmospheric Composition Monitor Assembly (ACMA) that would measure major and minor pollutants as well as particulate matter. [31.7.1] The Major Constituents Monitor (MCA) was originally a component of the larger ACMA, which also included a particulate monitor, carbon monoxide monitor, and a trace gas analyzer (gas chromatograph/mass spectrometer). As the space station design evolved, all systems were reconsidered and the emphasis on reducing size, power, and cost eliminated all but the MCA. As early as 1992, a plan was in place to use a stand-alone MCA for the early Man-Tended Capability (MTC) of the space station. [31.7.2] The first part of this section will describe the MCA instrument and its operation, while the second portion of this section will address real-time monitoring of trace volatile organic compounds (VOCs).

31.7.1 Major Constituent Analyzer

The ISS is a semi-closed environmental system where most of the air is recycled, but oxygen and nitrogen must sometimes be injected into the ISS atmosphere from storage tanks and arriving vehicles (i.e., Progress, ATV). The storage tanks are replenished when the Shuttle docks with ISS. Oxygen is consumed by the crew and both oxygen and nitrogen are lost to the inevitable tiny ISS leak rate. A small amount of air (relative to the ISS volume) is lost when the crewlock is reduced to 10.2 psia for Extravehicular Activities (EVAs) and more air is lost when the airlock pressure is reduced to vacuum (pressure outside ISS).

The entire ECLS system, including the MCA, is housed in the U.S. Laboratory’s (LAB) Air Revitalization Rack (AR). The six atmospheric components monitored by the MCA are oxygen, nitrogen, methane, hydrogen, carbon dioxide, and water vapor. Oxygen is monitored for the obvious purpose of protecting crew health. Additionally, the MCA maximizes resources by providing accurate oxygen concentrations to guide injections of oxygen into the atmosphere from storage tanks. Nitrogen is a valuable marker for detecting leaks, be it in the vehicle or the gas delivery system, since there are no

other nitrogen loss mechanisms. Additionally, a feedback loop uses the nitrogen and oxygen data to control total pressure in the ISS. Hydrogen and methane are human metabolic products [31.7.3] that are removed by the ECLS system to prevent accumulations that approach explosive limits. Hydrogen is also produced by onboard batteries; however, when the batteries perform nominally they contribute only a fraction of the total hydrogen build-up in the cabin. Carbon dioxide concentration, also a human metabolic product, must be maintained below the Spacecraft Maximum Allowable Concentrations (SMACs) in nominal operations to protect crew health. The SMAC (see section 31.6) for carbon dioxide is 1% by volume or 10,000 ppm. SMACs are defined as the permissible concentrations of contaminants in spacecraft atmospheres based upon health effects and other considerations (i.e., explosive hazard). Water vapor is monitored because its concentration is used to determine the dewpoint, which is the preferred means of controlling the air, temperature, and relative humidity. The MCA must be a reliable instrument that continuously provides the data necessary to assess that the ECLS system is functioning properly, so as to maintain crew health and safety.

The MCA's mass spectrometer was a modification of the design used for the medical mass spectrometers (MGAS and GAMS); however significant improvements were incorporated into the MCA to aid on orbit maintenance and long-term performance. The MCA has seven on-orbit serviceable components called ORUs (Orbital Replaceable Units) required to maintain this vital instrument aboard ISS. The seven ORUs are identified in Figure 31.7.1 [31.7.4].

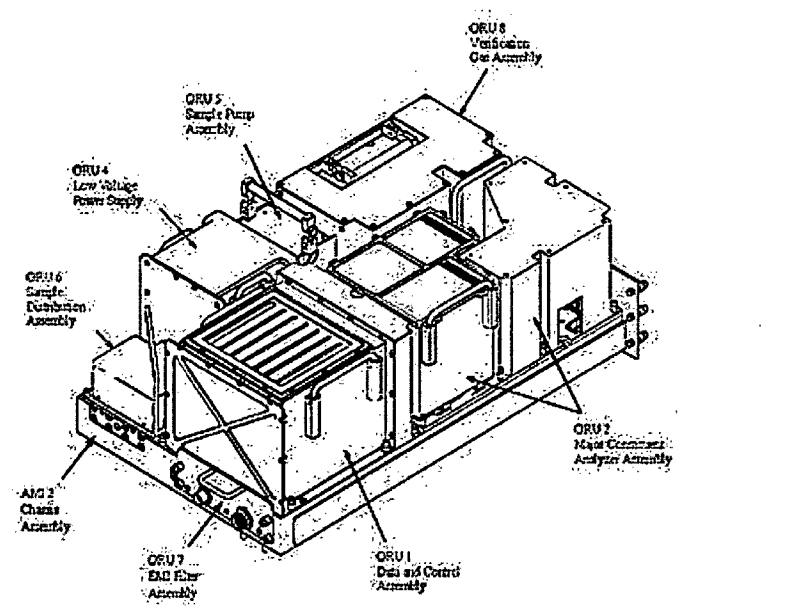

Figure 31.7.1 – MCA's Orbital Replaceable Units

The heart of the system is mass spectrometer assembly (ORU 02), shown in Figure 31.7.2. This ORU is comprised of the ion pump, ion source, mass spectrometer, inlet leak assembly, and supporting electronics. The MS is stainless steel with either welded joints or gold gaskets at flanges to maintain the vacuum. This is a single-focusing MS that receives a fraction of the sampled gas through a sintered metal leak. The ion source uses the standard hot filament to generate a 70 eV electron beam that ionizes

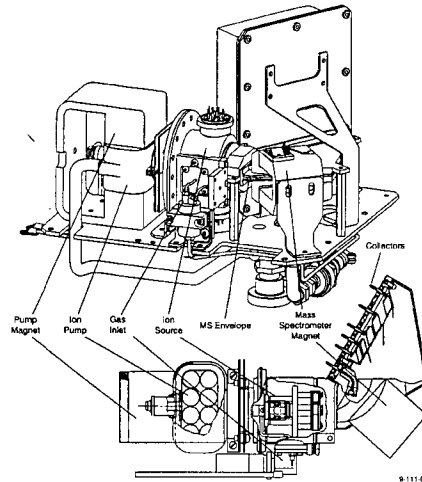

Figure 31.7.2 – Mass Spectrometer Assembly (ORU 02)

the analytes in the sample. Ions are extracted from the source and accelerated toward the magnetic sector (3700 gauss), where \ multiple Faraday cup detectors (one for each analyte) are arranged in the focal plane. The major advantage of this mass spectrometer configuration is its stability. All six detectors acquire data simultaneously for a 100% duty cycle. The ion currents, which are proportional to partial pressures, are converted to electrical signals by an electrometer. The processor sums all outputs, ratios each output to the sum and compares the sum to total pressure output (independent pressure transducer). This closed-loop calculation provides accurate partial pressures that are independent from sample flow variation or ion source changes in sensitivity.

The verification gas assembly (ORU 08) contains a mixture of the six analyte gases, in known concentrations, to insure the long-term drift is within tolerance limits. ORU 01 is the data processing and control assembly. Collected data are processed to arrive at analyte concentrations in ORU 01, and this information is transmitted to the ISS data management system (DMS) via a Mil-STD-1553 data bus. The series pump assembly (ORU 05) houses the sample pumps required to pull air through the sample lines to the inlet leak assembly of ORU 02. This component contains two pumps that provide

redundancy for this critical function. The pumps are connected to the solenoid valve manifold (ORU 06) via a stainless steel tube assembly. Heat generated by the pumps is dissipated through an air-cooled heat sink in ORU 05. The other two ORUs contain motherboards and low voltage power supplies (04) and electrical interfaces (07) to the air revitalization rack.

There are seven sample lines from the ISS complex that converge at the sample distribution assembly (ORU 06). Each incoming sample line is routed into a sampling valve in the aluminum manifold (Figure 31.7.3). A separate port and solenoid in ORU 06 are used to introduce the verification gas.

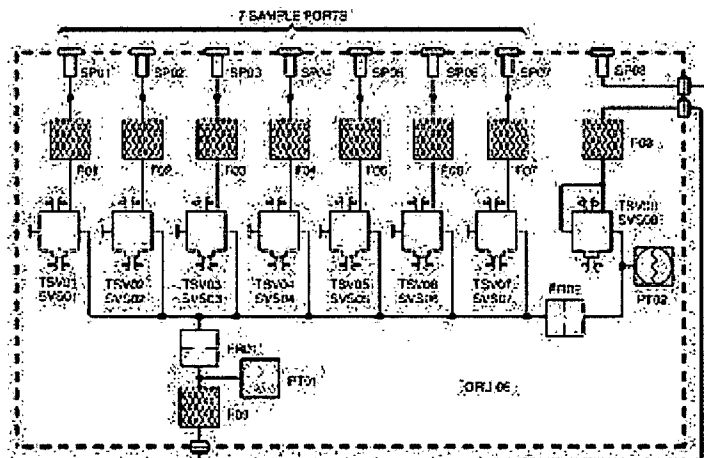

Figure 31.7.3 – Gas sampling assembly (ORU 06)

The performance requirements for the MCA are shown in Table 37.1.1. These requirements are for an ISS pressure of 14.7 (+0.5, -0.2) psia; however the MCA is required to operate from 9-15.2 psia with a relaxed accuracy requirement.

Table 37.1.1 – MCA Performance Requirements

Measured Gas	Maximum Partial Pressure (Torr ¹)	Accuracy (%FS)	Accuracy Band ²
Nitrogen (N ₂)	800	± 2	± 16 Torr
Oxygen (O ₂)	300	± 2	± 6 Torr
Hydrogen (H ₂)	50	± 5	±2.5 Torr
Methane (CH ₄)	25	± 5	±1.25 Torr
Water (H ₂ O)	25	N/A	N/A
Carbon Dioxide (CO ₂)	15	± 3	±0.45 Torr

¹ 760 Torr = 14.7 psia, ² in the total pressure range of 719 – 786 Torr (13.9 – 15.2 psia)

The most challenging analyte is carbon dioxide, because the very low detection limit of 0.15 torr requires an extremely large range given the upper part of the nitrogen band (800 torr). For this reason, the carbon dioxide accuracy requirement was raised from the original $\pm 1\%$ to $\pm 3\%$. Water accuracy was waived (non-specified) because ground testing demonstrated that condensation could persist in the long sampling lines.

The MCA performs two calibrations: Full and Zero. In the full calibration the unit uses calibration gases, of known concentration, to perform an absolute calibration that compensates for background signals, electronic offsets, and drift. The zero calibration only subtracts background levels and electronic noise. These data are used in the calculations of target gas concentrations. The final target gas partial pressures are derived by acquiring the amplified current signals from the Faraday cup detectors and applying engineering scale factors to convert the signal to engineering units. This is a linear function in which the raw counts are multiplied by a slope and added to an intercept. Slopes and intercepts are kept in non-volatile memory, but they can be adjusted from the ground, if necessary. Background values are obtained from the zero calibration data. Matrix gain and cross correlation coefficients are instrument specific, consequently they are determined in the laboratory prior to shipment of the MCA for launch. The electrometer correction values (ECVs) start at 1, but are adjusted as needed based upon the full calibration results. The ECVs track instrument drift for each gas. Seven sets of raw data from the six target gases are averaged and this value is converted to engineering units. The background for each gas is subtracted from its engineering value (average for each gas) and this is multiplied by the PPRM matrix (gain and cross-correlation coefficients) to get the intensity for each target gas. The intensities are multiplied by the corresponding ECV and these values are normalized to the sum of the adjusted intensities. The partial pressure for each target gas is then derived by multiplying the total pressure (independent measurement) by its normalized intensity. It should be noted that the water vapor channel was desensitized for this study. Although the requirement for oxygen accuracy was 6 torr, data acquired from flight and ground units shows a 2 torr error band within 12 weeks of full calibration. [31.7.5]

MCA (Figure 31.7.4a) was activated in Feb. 2001 on ISS. [31.7.6] There were several early problems with the MCA design and software, but eventually the MCA proved to be a reliable instrument. The MCA drawer (Figure 31.7.4b) allows easy access to components for maintenance. A few of

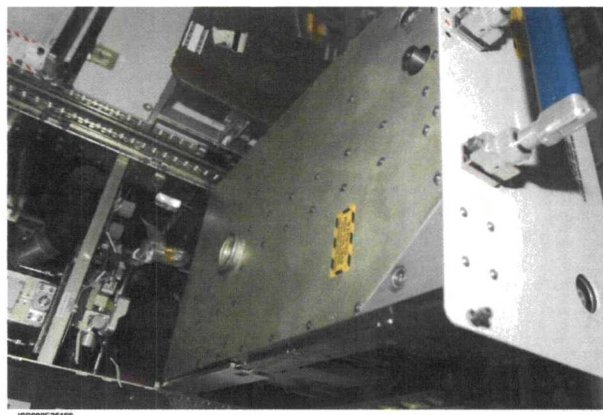

Figure 31.7.4a – MCA in ISS LAB

Figure 31.7.4b – MCA drawer

the initial problems are highlighted here. The inlet restriction sleeve over the inlet leak for sample introduction was a "press fit" instead of being welded, which caused saturation of the nitrogen electrometer. [31.7.7] This presented a serious problem since the sum of the electrometer's partial pressure for all six MCA target compounds must equal the total pressure. However, if the nitrogen electrometer is saturated, then the outputs for all target compounds will be inaccurate. [31.7.8] The problem was verified by comparing raw electrometer counts from the full calibrations over time, which showed increasing electrometer counts. A second problem cropped up when particles created by gaseous reaction ("getting" process of pump) with the ion pump, formed a cloud that drifted into the ionization region causing Penning ionization and ion pump upsets. This phenomena is usually observed near the pump's end of life in ground operations, but in microgravity of ISS this fault was appearing much earlier. MCA struggled with these problems until being shutdown in August 2001 while improved ORUs were being designed and built. These enhanced ORUs were sent to ISS and installed in July 2002 to restore MCA function. [31.7.9] In the meantime, portable electrochemical sensors were used to monitor O_2 and CO_2 in the ISS. [31.7.10] The new ORUs made MCA more stable, but microgravity continues to effect the pump causing noisy current and slowly increasing ion pump current that eventually leads to MCA shutdown. Consequently, the pump ORU is replaced more often than planned. A leak occurred in the verification gas module (Figure 31.7.5) during early MCA operations, but this problem was quickly traced to a manufacturing flaw in an o-ring (Figure 31.7.6) at the regulator to

manifold interface. [31.7.11 and 31.7.12] The o-ring was sized for external-internal pressure difference, but the system has internal-external pressure difference, which could have caused the o-ring to move as

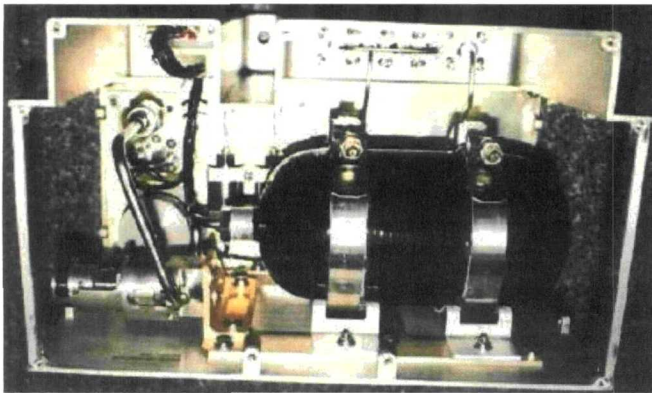

Figure 31.7.5 – Verification gas assembly (VGA)

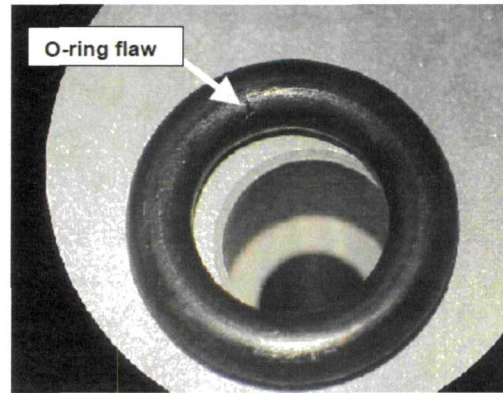

Figure 31.7.6 – VGA o-ring

pressure in the tank changed. Also, this could explain how the o-ring flaw escaped detection in the earlier assembly-level leak testing.

In spite of these problems, the MCA detected a small nitrogen leak on ISS, which was discovered by increasing N₂ partial pressure data. With the exception of the time period noted, the MCA has continuously monitored major constituents gases in the ISS atmosphere, including the airlock during EVA operations. Data from the MCA is plotted for 2008: trending oxygen (Figure 31.7.7a) and the other three gases (Figure 31.7.7b). Gaps in the data are occur when there was a wait for an ORU or other maintenance related to the MCA or air revitalization rack.

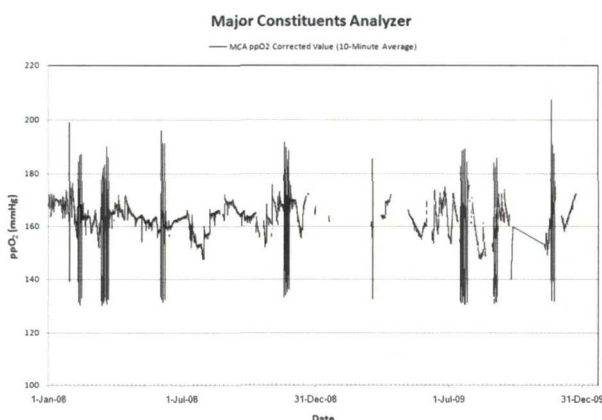

Figure 31.7.7a – MCA O₂ output 2009

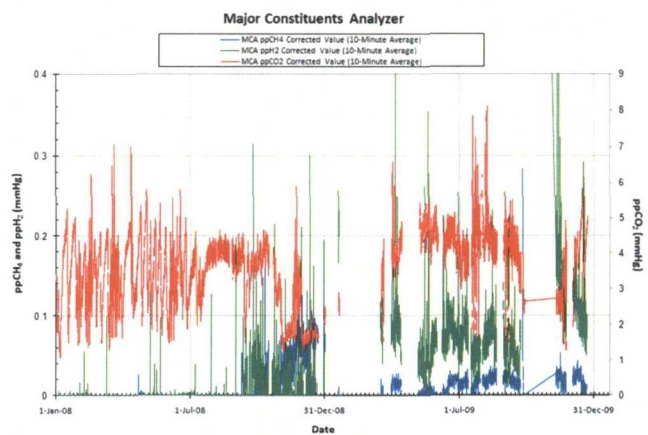

Figure 31.7.7b – 2008 Output: H₂, CO₂, CH₄

31.7.2 Complementary Analysis – Ion Mobility Spectrometry in Space

The International Space Station (ISS) operations involved two aspects that warranted real-time assessment of volatile organic compounds (VOCs): 1) long (>6 months) crew stays on orbit, and 2) the facility was to conduct a large number of scientific experiments and advanced hardware system tests. Experience from the Skylab [31.7.13] and Shuttle programs [31.7.14] and later confirmed during the Shuttle-Mir project [31.7.15], predicted that there would be air quality degradation events on ISS. These events might include leaks or spills from systems and payloads, overheated wiring and electronics, and failures of scrubbers recycling the air. The Shuttle-Mir program incidents showed that periodic archival sample return was not always adequate to address air quality issue on long-term spacecraft missions. A volatile organic analyzer was proposed as a real-time volatile organics (VOCs) monitor to complement archival sample returns from ISS. As stated in section 31.1.2, the Volatile Organic Analyzer (VOA), based upon gas chromatography- ion mobility spectrometry (GC/IMS) was selected as the first



Figure 31.7.8 – Astronaut Bonnie Dunbar operating VOA/RME on STS-89

instrument to measure trace VOCs in near real-time onboard a spacecraft. In the mid-1990s, NASA created the ISS risk mitigation experiments (RME), which used the Shuttle to assess the performance of complex operational hardware in microgravity. In microgravity there is no thermal convection, so it was unknown whether the heating and cooling of components (i.e., GC column) could be accomplished with the precision required to meet the VOA instrument performance requirements. The VOA risk mitigation experiment (VOA/RME) was flown on two

missions: STS-81 and STS-89 [31.7.16]. The VOA/RME contained a cylinder of carrier gas (nitrogen), which resulted in a two-box configuration (Figure 31.7.8). These were the only differences between the VOA/RME and the planned VOA. Results from multiple uses of the VOA/RME will be discussed later in this section.

The VOA was sent to ISS in August of 2001 and operated there until August 2009, with an inactive period from 2003-2005. A potential replacement for the VOA was flown to ISS in May 2009 as an

experiment and a discussion of this instrument, gas chromatography/differential mobility spectrometry (GC/DMS), will appear at the end of this section.

The VOA is composed of two channels, each having an inlet, a gas chromatograph (GC) interfaced to the detector (ion mobility spectrometer), pumps, and a controlling computer. A block diagram of the VOA is shown in Figure 31.7.9. The two channels provide almost redundant function if only one channel is functional. The VOA's pump pulls an air sample through two preconcentrators containing Carbotrap B and Carboxen 569 sorbents, which extract and concentrate most VOCs of interest. Heating the preconcentrators, with a flow of nitrogen gas, sends the VOCs to GC columns where the complex mixture is separated. The detectors are ion mobility spectrometers (IMS) that identify and quantify the compounds as they elute from the GC column. [31.7.17]

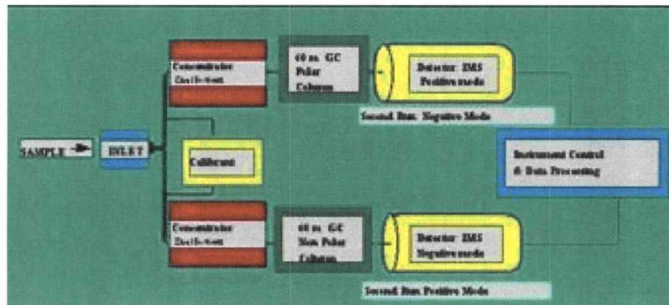

Figure 31.7.9 – VOA block diagram

Each detector responds to positive and negative ions, but not simultaneously; therefore two complete runs (Parts 1 and 2) are needed for each analysis. Two Quadrex stainless steel capillary columns are used: Channel 1 is a 60m x 0.5mm 1.5m UAC-5 (5% phenyl 95% methyl silicone) which separates nonpolar compounds and Channel 2 is a 60m x 0.5mm 2m UAC-502 (cyanopropyl methyl phenyl silicone) for polar compound separation. The GC and heater were coiled and layered around a metal former (25mm bore) resulting in temperature reproducibility better than $\pm 1^{\circ}\text{C}$. The detectors in the VOA determine the GC retention times and the ion mobilities for target VOCs, which it uses to provide accurate compound identification. The VOA determines the contaminant concentration by comparing the integrated area of the ion mobility peak to a calibration table. Compounds eluting from the GC columns are ionized in the IMS detectors by a 10 mCi ^{63}Ni source. The ionization is almost exclusively by charge transfer rather than direct ionization [31.7.18]. The ions (either positive or negative) are “gated” into the drift region during a 180us pulse. The ion's mobility is the time needed for it to

traverse the detector's drift tube under the influence of a weak electric field, which drives the ions toward the detector against a counter flow of scrubbed drift gas (VOA-air). The ions undergo multiple collisions with the drift gas; therefore its cross-sectional area (size and shape) determines the time required for the ion to reach the faraday cup detector. A faraday cup detector is used to convert the ions into an electrical signal (nanoamps). A biased aperture grid is placed close to the detector to protect it against charge build-up and to filter noise from the gate pulse.

The ion mobility is normalized for temperature, pressure, and electric field strength and is named the reduced ion mobility, k_0 (Equation 1). This equation is valid for weak electric fields (~200V/cm in the VOA detectors). Pressure and temperature sensor data are used to normalize the mobility as shown in Equation 31.7.1 and purely for mathematical convenience, the VOA calculates and presents data as the reciprocal of the reduced ion mobility ($1/k_0$).

$$k_0 = \frac{d}{E \cdot t} \left(\frac{P}{760 \text{ torr}} \right) \left(\frac{273 \text{ K}}{T} \right) \quad (31.7.1)$$

k_0 = reduced mobility ($\text{cm}^2\text{V}^{-1}\text{s}^{-1}$)

d = drift tube distance: shutter grid to electrometer (cm)

t = drift time of ion (seconds)

E = electric field strength (V/cm)

P = cell pressure (torr)

T = cell temperature (K)

The IMS detectors always have a standing current (hydronium and oxygen ion clusters in the positive and negative modes respectively) referred to as the reactant ion peak (RIP). Analyte peaks are ionized by charge transfer from the RIP ions (Figure 31.7.10a), which decreases the height of the RIP to produce the analyte peak (Figure 31.7.10b). Drift gas scrubbers control the moisture in the ionization and detector regions (~a few hundred ppm), enabling reproducible ion mobilities.

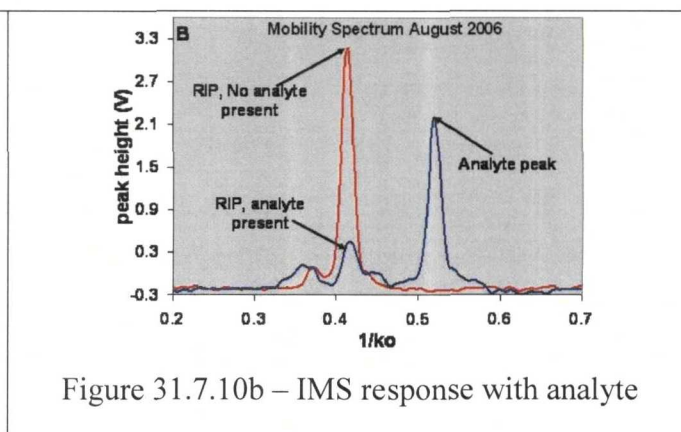
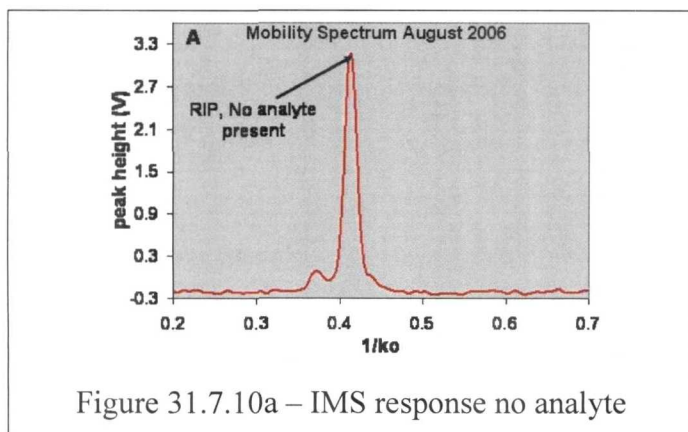

The VOA performs very fast scans over the ion mobility range (0-20ms), then 16 scans are averaged and stored (along with sensor data) every second of the run to produce smoothed spectra throughout the GC run. The RIP (Figure 31.7.11a) can be plotted (similar to the TIC of MS) with a single ion mobility for specific compounds and multiple mobilities (Figure 31.7.11b) can be graphed (analogous to SIM in MS). The mobilities for some analyte ions can be in close proximity to the RIP; therefore data processing involves background subtraction of the RIP by software (Figure 31.7.2.11b).

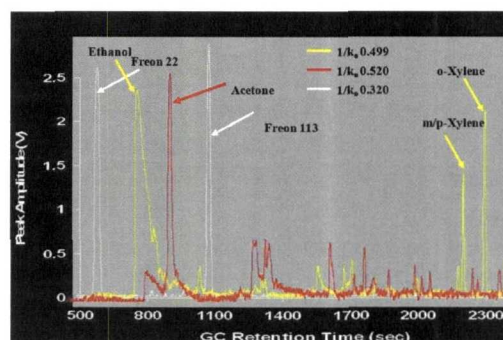
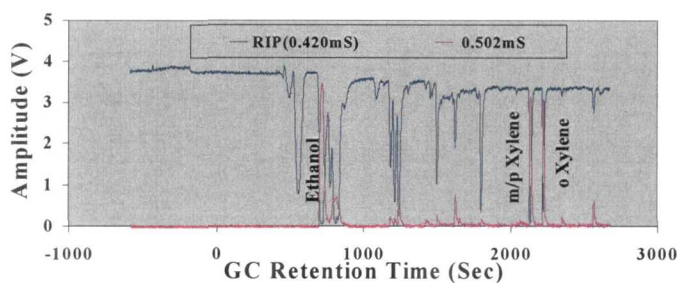

Compound identification and quantification is performed on the “charge” area (i.e., peak area) of the analyte’s ion mobility peak, not the GC peak.

Pinacolone (3,3 dimethyl-2-butanone) is the calibrant added to all runs as a check on instrument performance. . Prior to sampling, a flow of nitrogen constantly purging the calibrant oven is diverted through the preconcentrator and this adds the pinacolone to the preconcentrator. The previously described analytical sequence would begin after the sample is acquired. The calibrant’s GC retention time and mobility are verified as correct and the approximate charge area is compared to expected values to insure proper instrument operation.

An internal picture of the VOA is shown in Figure 31.7.12. The scrubbers and pumps were orbital replaceable units (ORUs) along with scrubbers for the nitrogen carrier gas, computer hard drive, cooling fan, and inlet nozzle filter (not visible in figure). The two components below the preconcentrators are 8-port, 2-position Valco valves (with valve drivers), which were the heart of the VOA's pneumatic system.

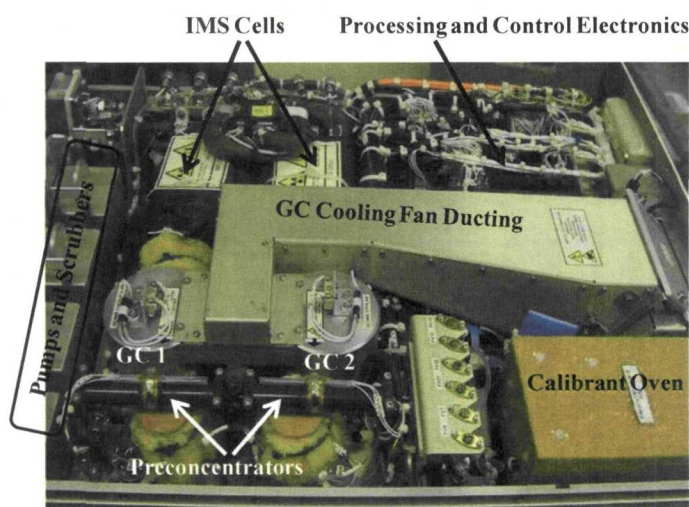

Figure 31.7.12 – Internal view of the major VOA components

These two valves directed sample, carrier, and purge flows through the appropriate components. All fittings and lines in the sample path were stainless steel and the entire path was heated to avoid losses of polar compounds to the walls. The nitrogen carrier gas was obtained from the ISS tanks as the VOA usage was miniscule. The IMS cells were operated slightly below ambient pressure and a “metered” leak maintained drift gas oxygen levels high enough for effective negative mode ionization. The VOA had a plethora of sensors that monitored temperatures, pressures, voltages, flows, valve position, and current.

The VOC target compounds on ISS were derived after reviewing archival samples from Shuttle and Mir as well as the compounds detected in offgas tests. Compounds frequently detected at measurable concentrations (i.e., acetone), toxic compounds (i.e., benzene) that could be found on spacecraft were added as targets, and compounds (i.e., 2-propanol) that can impact the ECLS systems (water recovery). The original VOA target compound list [31.7.19] was reduced to the compounds shown in Table 31.7.2. Most compounds removed from the original list were those that couldn't easily be chromatographed

(acetic acid), ones that could not be trapped by the preconcentrator (carbonyl sulfide), and those for which it was impossible to make reliable standards (2-butoxyethanol). The NASA toxicologist

Table 31.7.2 – VOA target compounds (shaded-must detect) and required detection limits

Compound	Conc. (mg/m ³)	Compound	Conc. (mg/m ³)
methanol	0.5	(F22) chlorodifluoromethane (or F12)	10
1-butanol	5	(F113) 1,1,2-trichloro-1,2,2- ???	5
m,p-xylene	10	ethanol	5
o-xylene	5	Benzene	0.1
propanone	1	Hexane	5
ethylacetate	5	2-methyl-1,2-butadiene	10
ethanal	0.5	(Halon 1301) trifluorobromomethane	10
toluene	3	ethylacetate	5
DCM	0.5	2-methyl-2-propanol	5
2-butanone	3	1,1,1-Trichloroethane	1

determined that the compounds removed from the list did not diminish the assessment of air quality by the VOA. The shaded compounds in Table 31.7.2 were those that must be detected, but allowance was made for qualitative analysis of 1 or 2 of these compounds. The VOA had to detect 80% of the remaining compounds. The detection limits shown in Table 31.7.2 were easily met by the VOA with the exception of benzene, which the VOA just met when the sample volume was reduced from 100 ml to 40 ml to accommodate the higher concentrations of other compounds in spacecraft samples. Most compounds are routinely detected below 1 mg/m³ on ISS, so the VOA's low detection limits for many compounds were a distinct advantage for the technique.

The VOA's precision requirement is very important, because in a contingency (i.e., fire, spill) the VOA data can be used to determine the effectiveness of clean-up and to add to the pool of information needed to inform the crew when they can remove their masks. For these reasons, the standard deviation for three consecutive VOA runs (clean run in between) could not exceed $\pm 20\%$. The VOA accuracy requirement was $\pm 50\%$, which to most seems like a very large allowance. However, consider that the data is compared to the SMACs, which themselves often have uncertainties exceeding $\pm 50\%$. Secondly, the EPA methods used for analysis allow a deviation of $\pm 25\%$ and $\pm 30\%$ for a few compounds (i.e., methanol); however the GC/MS analysis of the GSCs is considered the absolute

answer and the VOA must be within $\pm 50\%$ of those values. Therefore, the VOA accuracy requirement is tighter than it seems, but more importantly it meets the operational objective: provide the NASA toxicologist the data required to assess the spacecraft air quality. [31.7.20]

The VOA calibration began with the runs of individual compounds to establish GC retention times and ion mobilities, which are the two identification parameters. A database was created and a “large” two-dimensional identification window (GC retention time vs $1/k_o$) was established. The quantitative calibration then proceeded with 40 ml sample volumes of 5 mixtures, at different concentrations, but each containing all the target compounds and run in triplicate. The standards were prepared in 6-L Summa-treated canisters, but aliquots of the mixtures were transferred to sample bags (Teflon) to interface with the VOA for Part 1 sampling. Approximately 1.5 hrs after Part 1, the sample bags were refilled for Part 2 (detector polarity was reversed on each channel) sampling of the VOA analysis. The GC retention times and $1/k_o$ from these runs are used to firmly establish the identification windows. The analytical runs can be reprocessed by Trimscan (vendor supplied software) if the database is altered. It is imperative that these two parameters be reproducible and Table 31.7.3 shows data from VOA’s instrument calibration that demonstrates its excellent performance. The VOA’s two-part analysis took approximately 3.5 hours.

Table 31.7.3 – The percent relative standard deviation of the GC retention times and $1/k_{os}$ for the VOA target compounds. These data based upon runs of mixtures at 5 different concentrations.

Target Compound	% RSD Part 1 (n=18)		% RSD Part 2 (n=18)		Target Compound	% RSD Part 1 (n=18)		% RSD Part 2 (n=18)	
	GC RT	1/ k_o	GC RT	1/ k_o		GC RT	1/ k_o	GC RT	1/ k_o
1,1,1 Trichloroethane	0.47	0.16	0.11	0.13	2 Butanone	0.32	0.84	0.38	0.10
2 Propanol			0.50	0.08	Ethanol	0.32	0.10	0.48	0.09
Freon 113	0.68	0.15			Isoprene	0.47	0.08	0.65	0.06
Butanol	0.33	0.11	0.19	0.06	Benzene			0.23	0.11
2-Methyl-2Propanol			0.43	0.10	Toluene	0.15	0.41	0.12	0.42
Ethyl Acetate	0.49	0.14	0.34	0.09	Calibrant	0.17	0.10	0.26	0.07
Methanol			0.33	0.39	Dichloromethane	0.80	0.56		
m/pXylene	0.12	0.80	0.10	0.54	hexane			0.41	0.06
O-xylene	0.13	0.41	0.05	0.37	Halon 1301	0.44	0.20	1.31	1.54
Propanone	0.40	0.08	0.51	0.10	Ethanal			0.37	0.08
Calibrant (picanolone)	0.21	0.10	0.39	0.20	Freon 12/22	0.43	0.16	0.32	0.16

The data shows the stability of the VOA instrument for these important identification parameters. As an example, the GC retention time is 890 seconds for 2- propanol and the $1/k_o$ is 0.561. Therefore, the identification window would be set no smaller than three standard deviations: 890 ± 13 sec and $0.561 \pm$

0.001; however in practice the windows are usually increased if the “analytical space” permits (2009 VOA database: 890 ± 21 and 0.561 ± 0.015 for 2-propanol).

After the VOA was calibrated in June 2001, the calibration was verified by challenging the VOA with a mixture that mimicked the ISS atmosphere. The contents of the mixture were unknown to the analyst operating the VOA. The detailed results are reported in reference [31.7.21], so only a summary will be provided here. All samples volumes were 40 ml and a mass flow sensor controlled the sampling time to insure collection of 40 ml regardless of ambient pressure. Three consecutive runs of the challenge mixture were performed and the data reduced. Compounds in the mixture were properly identified in each run, which verified the identification capability of the VOA and the precision of the three runs met the precision requirement ($\pm 20\%$) for all compounds. The accuracy requirement was met for all but hexane (97%) and only two other compounds (ethanol and n-butanol) were greater than 30% error. In light of the excellent performance for all other compounds, the hexane was considered an anomaly and the VOA was shipped to KSC for launch.

The VOA/RME, the first VOCs monitor, was prepared for flight in similar manner to the process outlined for the VOA. The VOA/RME successfully collected data throughout the STS-89 mission. [31.7.22] Two important design issues were recognized after looking at the data and comparing results to GSCs taken simultaneously with the runs. First, the sample volume (100ml) was too large and this was reduced to 40 ml and 10 ml for all subsequent VOA and VOA/RME activities. Secondly, it was clear that there was significant carryover from one run to next; therefore, Graseby, designed new reverse flow valves to clean the preconcentrators following sample desorption. The reverse flow valves solved the carryover issue and they were incorporated into the VOA (and later the VOA/RME).

A unique opportunity arose to use the VOA/RME in submarine trials [31.7.23 and 31.7.24], when a joint effort between the U.S. Navy, United Kingdom (U.K.) Navy, and NASA was instituted to assess archival sampler performance on UK submarines. This study compared results from VOA/RME runs to those of simultaneously acquired archival samples. The VOA/RME eventually participated in two trials on UK submarines (Figure 31.7.13). The VOA/RME may be the only actual equipment ever to analyze air on orbit and under the sea. The results from the first trial led to improvements in the UK sampler design. Concentrations for a representative target compound from the trials, toluene are shown in the following figures. It can be seen in Figure 31.7.14 that the archival samplers produced erratic concentrations

compared to the VOA/RME in trial 1, but in trial 2 an improved archival sampler showed close agreement with the VOA/RME (Figure 31.7.15).



Figure 31.7.13 VOA/RME onboard submarine

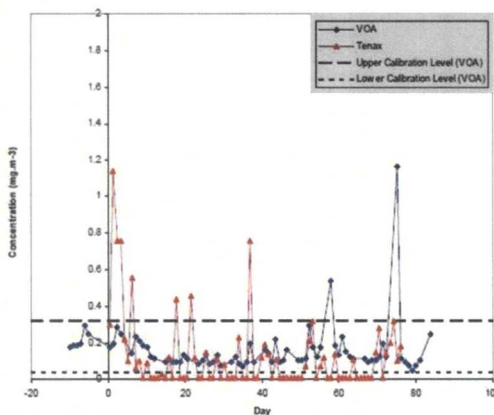

Figure 31.7.14: Trial 1: Toluene

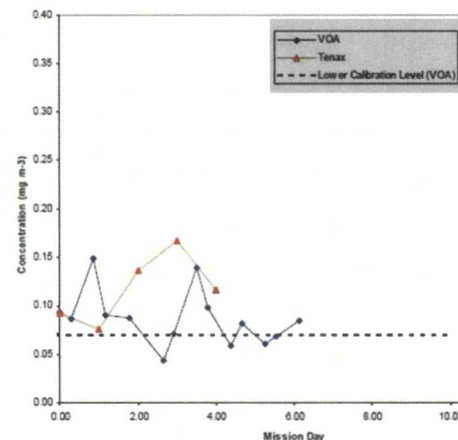

Figure 31.7.15 Trial 2 Toluene

The VOA was sent to ISS in August 2001 and activated in September 2001. A software issue between the VOA and the ISS 1553 communications bus led to intermittent operations for the first 6 months. The software issue significantly increased an already long validation time, consequently the first important use of the VOA occurred before it was formally validate. In February 2002, the ISS crew was preparing for an Extravehicular Activity (EVA) by regenerating METOX canisters (scrubbers for recycled air on EVAs). These canisters are a combination of charcoal and CO₂ absorbent that are renewed by baking the sorbents and sending the effluent into the ISS volume. Normally, only metabolic contaminants from a crewmember are collected on the sorbents during the 8-10 hrs of an EVA and this can be released into the volume of ISS without a degradation in air quality. However, in February the crew was driven to seek shelter in the Service Module because of strong odors not long after the METOX regeneration had started. These canisters had been used many times before without incident. Possible causes included degraded Metox catalyst beds and crew error that caused cabin air to flow through the Metox sorbent for six months. If the latter cause were true, then the odors would have been caused by the release of ISS contaminants collected on the METOX sorbents over a 6-month period. The METOX canisters were regenerated again in April 2002 and although GSC samples would be acquired, they would not be analyzed before the ISS program had to decide whether to send up new

canisters. Fortunately the VOA was available during the METOX regeneration and the two-part analysis allowed samples to be collected a couple hours apart. The results are summarized in Table 31.7.4, in which T=0 is when the METOX regeneration was started and T=2.5 hrs is the time predicted for the maximum contaminant release from the METOX regeneration. [31.7.25] The data indicate only a small rise in nominal contaminants supporting the view that a crew error and not sorbent degradation caused the large contaminant release in February 2002. The ISS program needed information to make a decision about whether to fly METOX canisters on the next Shuttle mission in a few weeks. The VOA was not yet validated for operations (see 31.7.26 for validation results), so ancillary data had to be collected to support the veracity of the VOA data collected during the METOX regeneration. First, GSCs collected in January 2002 and the latter part of 2001 were compared to the METOX data and it was found that the April data was representative of a nominal ISS atmosphere. Additionally, VOA sensor data confirmed that a 40 ml sample was acquired and that the preconcentrator and GC (flow and temperature profiles) performed nominally. Finally, a verification was required that compounds were correctly identified and quantified and this was done by comparing a ground calibration run (June 2001) to the data collected for two compounds in April 2002. The first compound was the late eluting compound, toluene, shown in Figure 31.7.16a. The GC retention times of all three runs are very

Table 31.7.4: VOA data collected during the METOX incident in April 2002

TARGET COMPOUND	T=0		T=2.5			180 Day SNAc	Lower detection limit
	Part 1 Metox 020402C*	Part 2 Metox 020402C	Part 1 Metox 020402D	Part 2 Metox 020402D			
	mg/m3	mg/m3	mg/m3	mg/m3	mg/m3		
methanol	X	0.134	X	0.229	9	0.04	
2-propanol	X	0.099	X	0.128	150	0.07	
2-methyl-2-propanol	X	trace	X	0.047		0.04	
ethanol	X	trace	X	0.064	4	0.03	
ethanol	52	1.61	52	2.3	2000	0.09	
1-butanol	0.113	0.168	0.107	0.178	80	0.09	
m-p-xylene		trace	trace	trace	220	0.42	
o-xylene		0.105	0.074	0.148	220	0.07	
toluene		trace	trace	trace	60	0.07	
isoprene		trace	trace	trace	3	0.12	
2-butanone		trace	trace	trace	30	0.04	
ethyl ethanolate		trace	trace	trace		0.06	
propanone	0.069	0.068	0.084	0.093	52	0.03	
benzene	X	0	X	0	0.2	0.04	
n-hexane	X	minute	X	trace		0.06	
calibrant	NA	123	98	133	NA	NA	
dichloromethane	0.083	X	0.102	X	10	0.03	
trien 22/12	0	0	0	0	470	0.04	
trien 113	0	X	0	X	400	0.07	
halon 1301	0	0	0	0	11000	0.07	
1,1,1-trichloroethane	0	trace	0	trace		0.04	

KEY: * Data from Results file. X: VOA does not detect compound on that channel. Trace: below calibration curve

close (<6 seconds in 1880) and the reduced mobilities (numbers in legend) are virtually identical. In Figure 31.7.16b, the plot for 2-propanol, an early eluting compound, shows the same correlation with the initial calibration in 2001. The toluene sample concentration seems appropriate compared to the calibrant concentration. The 2-propanol response is non-linear, so the sample peak to calibrant peak ratio is actually close to the expected value. Based upon VOA data and other input (i.e., crew impression of the air quality), the ISS program decided not to send more METOX canister and to continue using the ones already onboard. The verification of the VOA's performance came when the GSCs acquired during the METOX April regeneration were returned and analyzed about a month later. The data in Table 31.7.5 show good agreement between the two methods, especially considering the GSC samples were acquired at the Node vent (close to METOX regeneration) while the VOA is located in the LAB module.

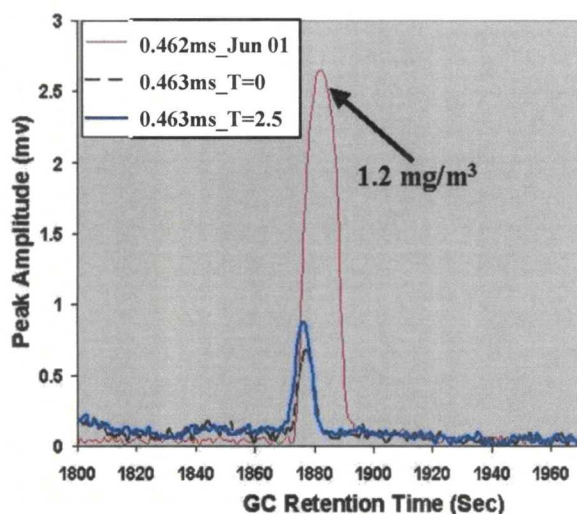

Figure 31.7.16a – Comparison of toluene peaks

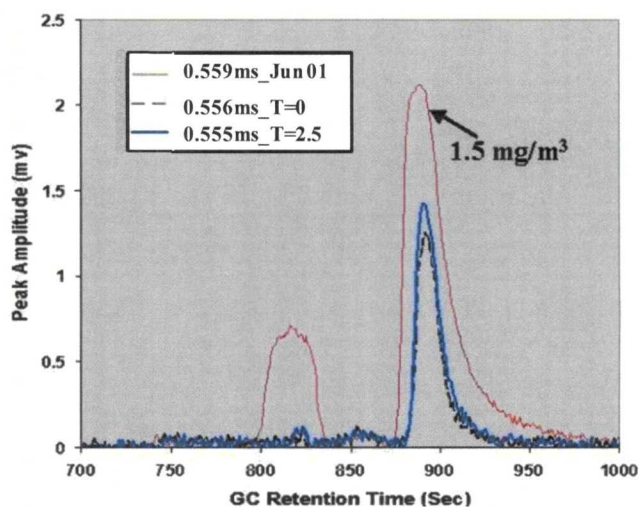

Figure 31.7.16b – Comparison of 2-propanol peaks

Table 31.7.5 – Comparison of VOA and GSC data during the METOX regeneration in April 2002

TARGET COMPOUND	T = 0		T = 2.5	
	VOA 020402C 1026 mg/m3	GSC SN1073 4/2:1037 mg/m3	VOA 020402D 1553 mg/m3	GSC SN1040 4/2:1340 mg/m3
methanol	0.13	0.51	0.23	0.29
2-propanol	0.10	0.09	0.13	0.10
2-methyl-2-propanol	trace	ND	0.05	trace
ethanal	trace	0.17	0.06	0.16
ethanol	>2	2.50	~2.3	2.50
1-butanol	0.11	0.09	0.11	0.09
mp-xylene	trace	trace	trace	trace
o-xylene	0.11	0.24	0.12	0.23
benzene			ND	trace
toluene	trace	trace	trace	trace
isoprene	trace	ND	trace	ND
2-butanone	trace	trace	trace	trace
ethyl ethanoate	trace	trace	trace </td <td>trace</td>	trace
propanone	0.07	0.12	0.09	0.20
dichloromethane	0.08	0.16	0.10	0.20

The Russian Elektron produces oxygen for ISS via water electrolysis and the oxygen then enters the ISS after passing through several filters. In September 2006, the crew had been working for several hours to restart the Elektron, but once it began operating the crew noticed white smoke being released from the unit. Initially thinking it was a fire, the crew enacted the ISS fire protocol, which led to the quick

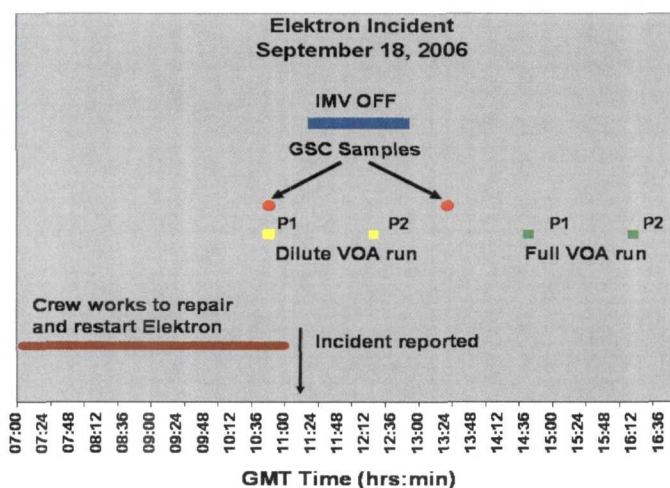

Figure 31.7.17 – Timeline for Elektron event showing Elektron events, VOA runs, and GSC sampling

deactivation of the intermodular ventilation (IMV). The VOA was operating during this event as shown in the Figure 31.7.17 timeline. [31.7.27] The timeline shows part 1 of the dilute run (10ml sample) occurring before the crew detects the incident and the full (40ml sample) run occurs a couple hours after the GSC sample. It should be noted that the VOA is located in the LAB module and the Elektron is in the Service Module. While there is reasonably good mixing between the module, there is still a time delay and a dilution factor that must be considered when assessing at the data. The graph in Figure 31.7.18 compares the dilute run during the incident to a nominal run (Nov 14). The mobility selected for this graph is that of the xylenes. The peak with the question marks was not in the database, but it was quickly recognized as ethylbenzene and other information later confirmed this hypothesis. In Figure 31.7.19 the concentration of key compounds is shown during the timeline of the incident, including samples prior to and after the incident for comparison. The main point of this graph is that the intermodular ventilation was off for an hour before the VOA sample was acquired, yet there is significant increase in the compounds associated with the incident. Crew actions (continuing to try to restart the Elektron) and the VOA data are strong indicators that the incident was underway before the crew noticed the problem. No contaminants reached harmful concentrations, but the value of real-time air quality monitors can be seen in that it was months before GSCs were returned and analytical results known. Furthermore, this incident showed the capability of air quality monitors to provide early warning of an incident-a key issue for long-term exploration missions.

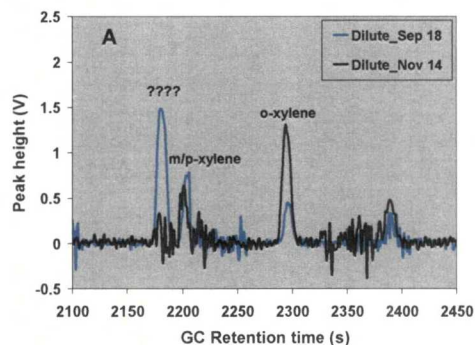

Figure 31.7.18 – Positive mode dilute runs

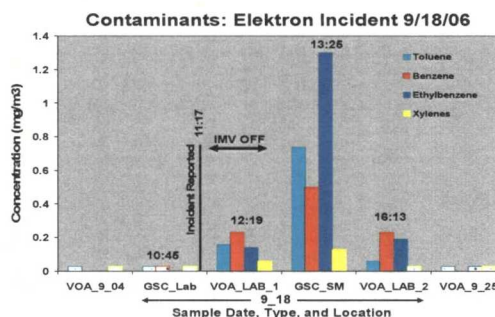

Figure 31.7.19 – Trending of contaminants

Instrument Configuration-microAnalyzer™

In 2005, Sionex released a research-configured gas chromatograph/differential mobility spectrometer (GC/DMS), called the suitcase, which was used to compare performance of this new technology to the VOA. [31.7.28 and 31.7.29] The assessment of the suitcase model confirmed that VOCs could be desorbed from sorbent materials and sent through a GC column using air as a carrier gas. This was a significant breakthrough in the development of a small VOCs monitor because it eliminated the need for high-pressure gas cylinders or an interface with spacecraft gas supplies. Furthermore, the suitcase performance was impressive in measuring the low-molecular-weight polar compounds, which are many of the important analytes detected in spacecraft air. Two years ago Sionex began production of the first microAnalyzers™, which combined an inlet preconcentrator and a GC column interfaced to the DMS detector in an extremely small package. [31.7.30] The data presented in this section was collected using the microAnalyzer™ (Figure 31.7.20). The only additional peripherals for the MicroAnalyzer™ are a power supply and a laptop computer. A block diagram of the microAnalyzer™ is shown in Figure 31.7.21. A pump pulls an air sample through a small preconcentrator (Carbotrap B and Carboxen 1000), which removes the volatile organics from the air. The preconcentrator is heated to 300°C to desorb and transfer the VOCs to the head of the GC column (Varian VF-624MS 15m x 0.25 mm x 1.4 μm). The GC column separates the complex mixture into its components and presents them to the detector.

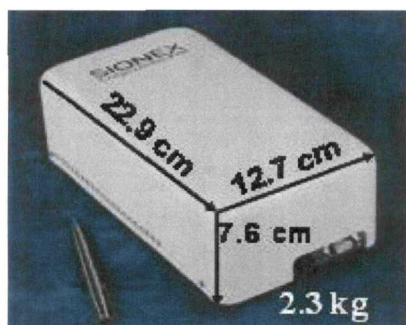

Figure 31.7.20 – microAnalyzer

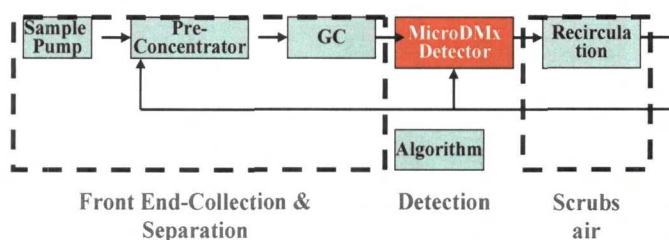

Figure 31.7.21 – microAnalyzer™ block diagram

The detector measures two important parameters for each analyte: the GC retention time and the compensation voltage (V_c). The peak area of the GC trace at a specific V_c is used to quantify the analyte concentration. The analyte ionization is identical to that described for the VOA, but the detection mechanism for the DMS, shown in Figure 31.7.22 is quite different.

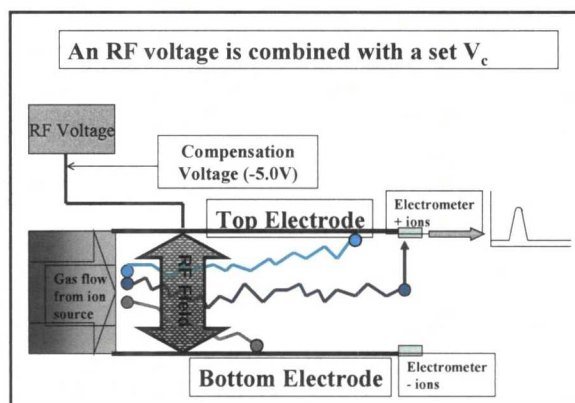

Figure 31.7.22 – Ionization and separation mechanism

The detector is composed of two closely-spaced electrodes through which the gas flow (GC column and make-up streams) moves the analyte ions from the ionization region to the electrometer, where they are detected. A radio frequency (RF) field, applied across the electrodes, is an asymmetric square wave with high and low field components cycling at 1.2 megahertz. The effect of these RF fields on the ions separates them in the vertical axis (direction of arrow labeled RF), as the gas flow pushes the ions toward the detector. The RF fields will push most ions to the walls before they reach the detector, unless a coupled voltage (compensation voltage V_c) is applied. Selection of the proper RF voltage and V_c for a compound will permit its ion to reach the detector, while other ions (formed in the ionization region) are driven to the walls. This provides the selectivity for ion detection even when several components elute from the GC column simultaneously. Greater detail on the detector can be found elsewhere. [31.7.31 and 31.7.32]

Calibration and Results-microAnalyzer™

The microAnalyzer™ was prepared for an experiment on ISS: a Station Detailed Test Objective (SDTO). Preparation was very similar to that described for the VOA, although the target list (Table 31.7.6) was reduced, because this was an experiment rather than operational hardware. [31.7.33] As with the VOA, the microAnalyzer™ starts calibration by establishing identification windows using GC

times as one parameter, but the other dimensional parameter is the compensation voltage (Figure 31.7.23).

Table 31.7.6 – microAnalyzer™ SDTO target list

Acetaldehyde	Dichloromethane
Methanol	Toluene
Ethanol	Xylenes (o,m,p)
Acetone	2-Butanone
Isopropanol	hexane
1-Butanol	Benzene
Ethyl Acetate	Octamethylcyclotetrasiloxane

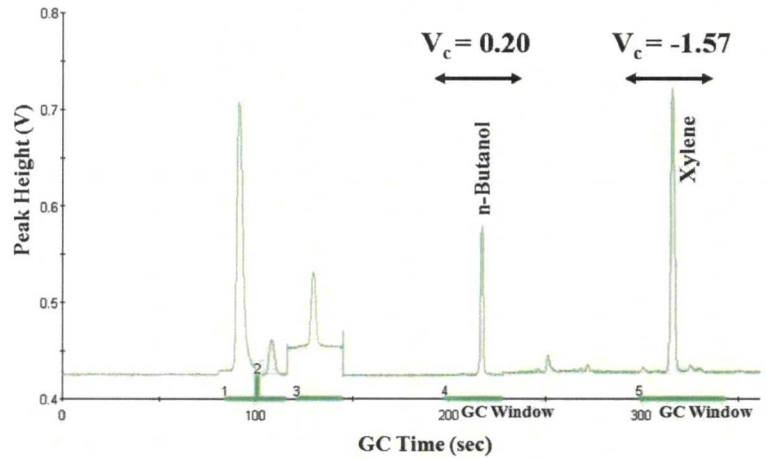

Figure 31.7.23 – Peak windows for n-butanol and m/p Xyenes

An independent unknown mixture, which included ~1% carbon dioxide and 40% RH, was used to verify the instrument calibration and function. The automated results of the unknown challenge mixture showed 100% accurate identification of the components and 73% of the compounds accurately quantified ($\pm 40\%$). Manual integration of two closely eluting compounds (methanol and acetaldehyde) produced an accuracy level greater than the 80% requirement. These results, along with the excellent precision of the data demonstrated the microAnalyzer™ was ready for the SDTO experiment.

The microAnalyzer™ has the capability to display results within a few seconds of the analysis completion; however, because the microAnalyzer was an experiment the crew did not have access to this information. The first step in the assessment of the microAnalyzer™ experiment was to evaluate the precision of the peak parameters used to identify the target compounds. Representative GC traces (long runs) over the microAnalyzer’s operational period are shown in Figure 31.7.24.

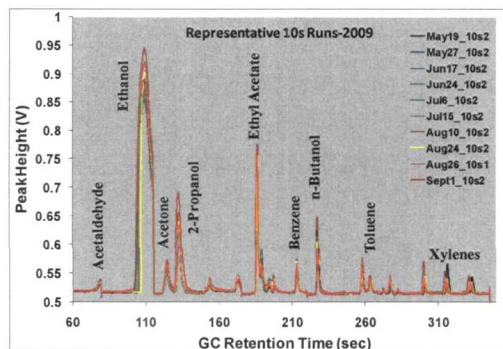

Figure 31.7.24 – microAnalyzer GC run reproducibility May-September

Excellent GC peak precision, together with the stable V_c , meant accurate compound identification. The concentration of most compounds remains relatively constant in nominal conditions and that was the pattern observed. This confirms that the microAnalyzer™ has been working nominally and producing excellent results, but how accurate are the results?

Data samples through July for ethanol and acetone concentrations from GSCs, microAnalyzer™, and VOA are shown in Figures 31.7.25 and 31.7.26, with the GSC error bars set at $\pm 40\%$. The first two GSCs were acquired during microAnalyzer™ runs, but the last one (July 22) was sampled days away from the microAnalyzer runs due to operational issues. The microAnalyzer accuracy was generally good when compared to the GSCs. [31.7.34]

The microAnalyzer was operating during the hatch opening of the MPLM (Multi Purpose Logistics Module-supply vehicle) on September 1, 2009 and the results have boosted confidence in the instrument's capability. This event provided an opportunity to assess the microAnalyzer™

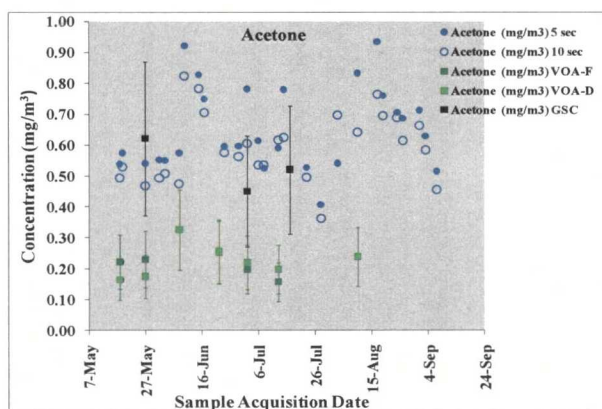
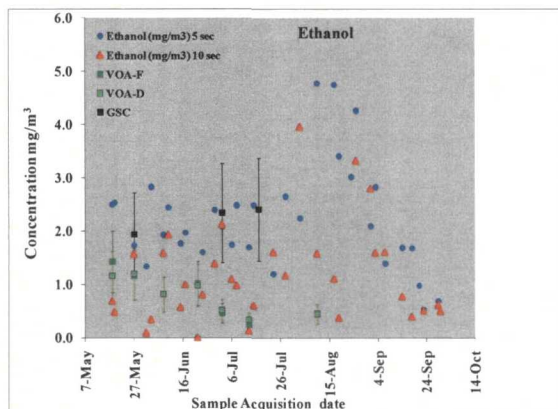

Figure 31.7.25 – Ethanol May-September 2009

Figure 31.7.26 – Acetone May-September 2009

response to a changing environment. The microAnalyzer was located in the LAB, but very close to the hatch leading to Node 2, where the MPLM was docked. The microAnalyzer™ data for 2-propanol on September 1 is shown in Figure 31.7.27. Soon after the hatch was opened, the 2-propanol concentration began to increase significantly compared to concentrations prior to hatch opening. A GSC sample was obtained in the MPLM within 15 minutes of the hatch opening and analysis of this sample revealed the 2-Propanol concentration to be 6.7 mg/m^3 . The ratio of the Node 2-LAB volume to the MPLM volume

was used to estimate the dilution effect. Accounting for dilution, 1.67 mg/m^3 was the highest expected LAB concentration. The microAnalyzer™ indicated a high value of 1.1 mg/m^3 for 2-propanol. [31.7.35] This close agreement with the GSC sample further verified the microAnalyzer's capability and greatly increased the confidence in this instrument.

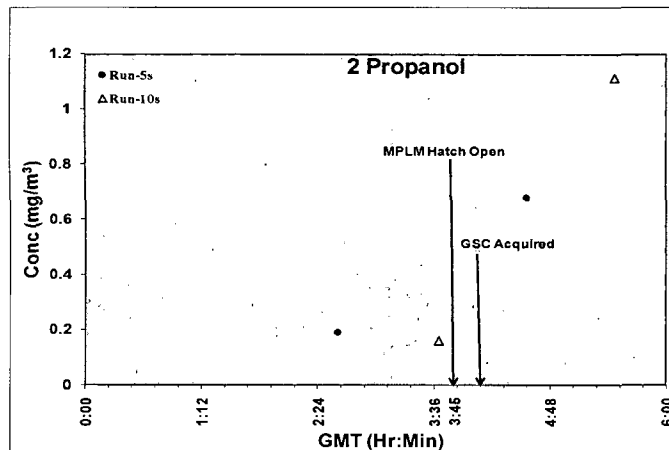

Figure 31.7.27 – Timing of September 1 hatch opening and the microAnalyzer™ results

31.8 Mass Spectrometers supporting Aerobee and Javelin Rockets

Section by John Hoffman

The initial instruments flown to study the composition and number density of the lower ionosphere were Bennett radio frequency mass spectrometers.[31.8.1] They were termed ion mass spectrometers because they were only sensitive to charged atoms and molecules since they did not incorporate an ion source.

Bennett Radio frequency mass spectrometers consisted of open ended tubes, 4 to 5 cm in diameter, and 15 to 20 cm long mounted to look radially outward from a cylindrical section of a rocket. The entrance aperture was a plane grid mounted on the tube end flush with the rocket's surface, usually set at 6 volts that served to extract ions from the surrounding atmosphere.

incremental energy to ions which were resonant as they traversed the analyzer; subsequently, a retarding potential barrier was applied to inhibit detection of ions that had not gained the maximum energy within the analyzer. The instrument was identified as an RF spectrometer since the incremental ion energy was

imparted by an RF potential (V_{RF}) applied to each of several RF stages within the analyzer. The sequencing of mass analysis within the chosen range of ion masses was accomplished by stepping the negative voltage (V_a); this accelerated the positive ions down the longitudinal axis of the analyzer, through the several RF stages, and toward the retarding potential barrier established by a positive potential (V_s). For a particular value of the accelerating voltage (V_a), the resonant velocity was imparted to ions of mass numbers that were in synchronism with the phase of the V_{RF} imparting the maximum energy to these resonant ions. Only the ions with the maximum energy were able to penetrate the retarding potential barrier and reach the Faraday cup collectors. The sensitivity of this instrument was very high due to the large cross section of the tube, but its mass resolution was just adequate to separate the ionospheric ions.

Magnetic sector field mass spectrometers, which have a long history of use in laboratories for such topics as measurements of the isotope ratios of the elements, nuclidic mass determinations and geochronology studies were introduced to space research through flights on Aerobee rockets. They employed a magnetic field for mass separation. Laboratory versions of these instruments typically have radii of curvature of the magnetic field from 6 to 12 inches. For the flight instruments the radii had to be reduced to the range of 1½ to 2½ inches. [31.8.2] Permanent magnets were utilized as there was not sufficient electric power available on the rockets to operate electromagnets. Typically, a mass spectrometer generates positive ions from neutral gas molecules by electron bombardment in the ion source. Resulting ions are accelerated out of the ion source, collimated into a beam and passed through the magnetic analyzer through a collector slit to an ion detector. In the early work, the ion accelerating voltage was produced by periodically charging a large condenser up to 2000 volts, and letting the voltage decay through a resistor to cover the desired mass range depending on the magnetic field strength. The exponential nature of the decay approximated a hyperbola, giving roughly a linear mass scale. Ions were measured by either a range changing electrometer amplifier or a logarithmic electrometer amplifier to provide a dynamic range of 3 to 6 orders of magnitude.

31.9 Mass Spectrometers Supporting Explorer 31 Argo D-4 rocket flight and the ISIS Satellite Program.

The ion mass spectrometer (IMS) consisted of a 1½ in. radius 60° sector-field magnetic analyzer (permanent 2200 gauss magnet) with an electron multiplier detector followed by a 6 decade logarithmic electrometer

amplifier. [31.9.1] An entrance aperture covered by a fine wire screen at -6 V with respect to the vehicle skin potential and mounted normal to the vehicle spin axis extracted ions from the atmosphere into the instrument, where a negative sweep voltage (-4000 to -200 or -150) produced a mass scan of 1 to 20 Da for a satellite or 1 to 32 Da for a rocket with a period of 2 or 3 sec. An internal calibrator in the logarithmic amplifier supplied currents of 10^{-11} , 10^{-9} , 10^{-7} Amps to the amplifier input periodically, enabling the amplifier output voltage to be related to input current.

The mass spectra were produced serially by a repetitive high voltage sweep circuit, as is shown in Fig 31.9.1. The position of each peak in the spectrum identifies the ion species, and the amplitude of the peak is proportional to the logarithm of the concentration of ions that were in the vicinity of the entrance aperture, which were dependent on the satellite attitude and velocity. The amplifier output voltage had a complex relation to the ambient ion concentration. An in-flight calibration, described below, was necessary to obtain absolute ion concentrations.

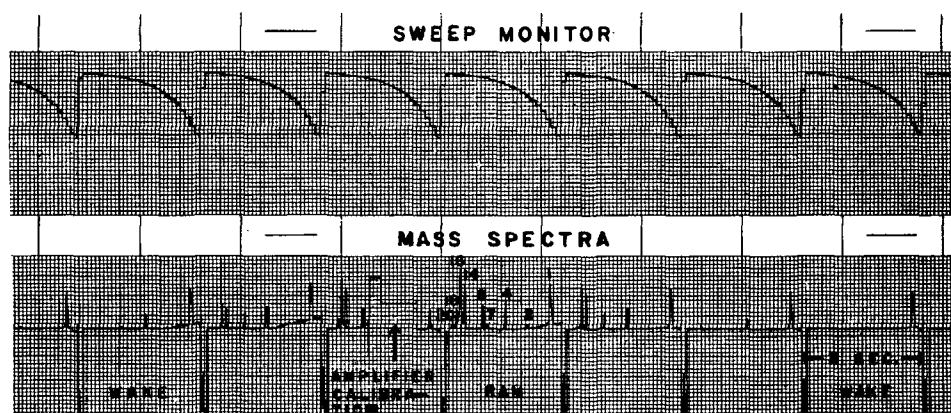

Fig. 31.9.1 Portion of analog telemetry record. Upper channel is sweep monitor.
Lower channel is mass spectrum.

The data from the satellite experiment showed considerable roll modulation due to the high vehicle velocity with respect to the mean ambient ion velocities and the side mounted (normal to the spin axis) entrance aperture of the mass spectrometer. However, since the satellite orientation was maintained in a cartwheel (spin axis normal to orbit plane) configuration and the angle of attack was known, it proved most practical to use only the data taken in the ram direction, when the instrument had its maximum sensitivity to each ion species. The rocket data were also roll modulated. Detailed knowledge of the rocket attitude allowed an empirical correction relative to the ram position to be made for each ion peak amplitude.

An ion mass spectrometer measures relative abundances of the ions it samples from the ionosphere. [31.9.2] Calibration of the instrument can be done to give absolute ion concentrations, as is described below. For example, an in-flight calibration was done for the Explorer XXXI mass spectrometer by comparing the total ion current (the sum of all the peaks) with nearly simultaneously acquired electron density data from the Alouette II topside-sounder satellite. The Alouette II and Explorer XXXI satellites, launched piggyback into similar orbits, were less than 30 minutes apart in a given latitude for the passes used in this calibration, and it is assumed that both satellites were measuring the same ionosphere for these calibrations. Comparisons were first made in regions of almost pure H^+ ($> 99\%$) of various concentrations up to 10^4 ions/cm, then, in regions of greater than 95% O^+ in the range of 10^2 to 5×10^5 ions/cm³. Other ion species were calibrated by interpolation. The overall precision of the measurements, after applying this calibration procedure, was $\pm 10\%$ as was demonstrated by comparisons with other Alouette II data and the other direct measurements probes on the Explorer XXXI satellite.

Since data from a spin stabilized cartwheel orbit satellite like Explorer XXXI are highly roll modulated, and only the ram position data are used, the spatial resolution of the data is of the order of 100 to 200 km for spin rates of 2 to 3 rotations per minute. On an oriented satellite when the angle of attack is maintained near 0° the spatial resolution is the product of the mass spectrum sweep period and the vehicle velocity, normally from 6 to 20 km.

A magnetic deflection mass spectrometer exhibits good mass resolution and sensitivity as evidenced by the Explorer XXXI data. Ten different ion species have been observed between m/e 1 and 20 Da at $1(H^+)$, $2(D^+)$, $4(He^+)$, $7(N^{++})$, $8(O^{++}$ or $He_2^+)$, $14(N^+)$, $15(^{15}N^+)$, $16(O^+)$, $18(H_2O^+$ or $^{18}O^+)$ and $20(Ne^+)$ Da. All except m/e 15 can be seen in Fig. 1. The sensitivity of the Explorer XXXI mass spectrometer to H^+ ions was ~ 0.3 ions/cm³ and to O^+ ions ~ 10 ions/cm³ [31.9.3].

In flight calibration of the ISIS ion mass spectrometer was done by comparisons of data from the retarding potential analyzer, RPA, and the Langmuir probe on the ISIS satellite. [31.9.3] The ISIS satellite had an onboard magnetic torquing system that allowed the orientation of the spin axis to be set perpendicular to the orbital plane (a cartwheel orientation) or aligned in the orbital plane. Most of the ion data were obtained in the cartwheel configuration where the total ion concentration could be directly compared to the ion data from the RPA.

31.10 Mass Spectrometers supporting Apollo Missions

31.10.1 Lunar Apollo Flights 15 and 16 Mass Spectrometers

The configuration of the instrument mounted on a retractable boom utilized on the Apollo 15 and 16 flights, Chapter 31.1.1, is shown in Figure 31.10.1 [31.10.1]. The plenum contained the mass spectrometer ion source (a Nier type) that employed redundant tungsten (with 1% rhenium) filaments mounted on either side of the ionization chamber. An emission control circuit activated by the ion source switch (ON position) in the command module powered the filaments. Two small heaters, consisting of ceramic blocks with imbedded resistors, were mounted on the sides of the ionization chamber. To outgas the ion source during flight, these heaters were activated by the ion source switch (STANDBY position). The ion source temperature reached 300°C in 15 minutes. Several outgassing periods during the flight maintained the ion source in a reasonably outgassed state.

The mass analyzer was a single-focusing permanent magnet with second order angle focusing achieved by circular exit field boundaries, giving a mass resolution of better than 1% valley at mass 40 Da. Voltage scan was employed utilizing a stepping high-voltage power supply. The ion accelerating voltage sweep was generated by varying the sweep high voltage in a series of 590 steps from 620 volts to 1,560 volts with a dwell time of 0.1 second per step. Between each sweep, the background counting rate was measured. Mass number of the ion being detected was determined by the voltage step number at which the peak was detected.

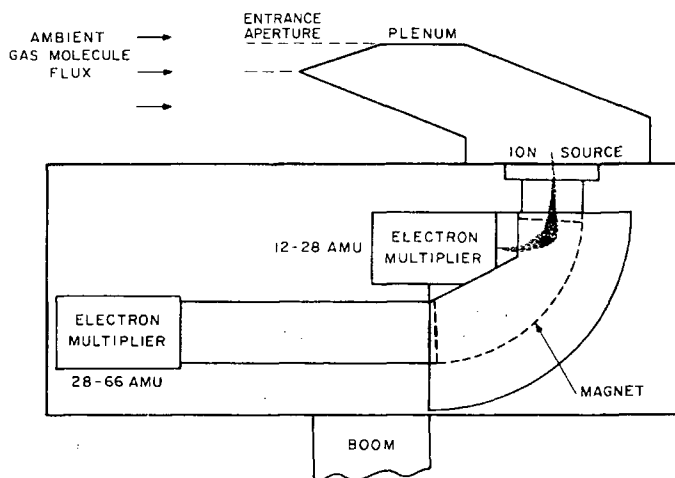

Fig. 31.10.1 . Schematic drawing of the magnetic analyzer, showing ion source, plenum, and magnetic analyzer with two ion beam trajectories. The entrance aperture points in the $-X$ direction. When the spacecraft velocity is $-X$, ambient gas molecules would be directed into the plenum, as shown by the arrows, due to the high spacecraft velocity with respect to the ambient average molecular speeds..

The system utilized a two collector system that permitted simultaneous scanning of two mass ranges, 12 to 28 Da and 28 to 66 Da. The detector systems employ electron multipliers, preamplifiers, and discriminators, which count the number of ions that pass through each collector slit on each of the sweep voltage steps. The ion count numbers are stored in 21-bit accumulators (one for each channel) until sampled by the scientific data system, a 64 kilobit/sec telemetry link to earth. Just prior to sampling, each data word is compressed pseudo- logarithmically into a 10-bit word consisting of a 6-bit mantissa and a 4-bit exponent. This system maintained 7-bit accuracy throughout the 21-bit range of data counts.

Instrument parameters, such as certain internal voltages, electron emission in the ion source, filament currents (to determine which filament was operating), multiplier voltages, sweep voltages, temperatures, multiplier and discriminator settings, and instrument current were monitored by a housekeeping circuit.

Initial calibration of the mass spectrometers, performed in a high vacuum chamber at The University of Texas at Dallas (UTD), verified that the proper mass ranges were scanned, and tested the resolution, linearity, mass discrimination, and dynamic range of the analyzer. These tests were performed by introducing Neon into the vacuum chamber with isotopic partial pressures ranging from 10^{-11} to 10^{-7} Torr. The instrument response was linear up to 1×10^{-8} Torr where the onset of saturation of the data- counting system occurred. The sensitivity of the instrument was verified to be greater than 3×10^{-5} A/Torr enabling the instrument to measure partial pressures down to 10^{-13} Torr. The uncertainties in the introduction of gases into the chamber, in the pressure measurement and in the wall effects precluded the determination of the absolute sensitivity in the UTD chamber.

The absolute calibration was performed in the Langley Research Center Molecular Beam Facility (MBF) [31.10.2]. The mass spectrometer was mounted in the MBF with the electronics package in the guard vacuum of the system and the plenum aligned with the axis of the chamber. A molecular beam, formed in the cryo-pumped chamber from a molecular furnace, impinged on the entrance aperture of the plenum. An externally controlled mechanical linkage allowed the plenum beam angle to be varied from 0° to 40° with reference to a horizontal axis perpendicular to the beam axis (the spacecraft yaw direction). Pitch angles of

- 5°, 0, and + 5° (with reference to a vertical axis perpendicular to the beam axis) could be set manually with the system open. Separate tests were conducted with a combination of the three pitch angles and various yaw angles from 0° to 40°. The mass spectrometer inlet was completely enclosed by a 4.2°K extension copper tube so that the back scattering of molecules into the inlet was essentially eliminated. The 4.2°K extension tube was enclosed by a 77°K wall of the guard system.

A large amount of data was generated from these tests using three flight instruments and one qualification model. The output counting rate for neon and argon as a function of MBF beam flux, 10^{10} molecules per $\text{cm}^2\text{-sec}$, was equivalent to 6.5×10^{-12} torr of argon in the plenum. Pressures below 10 - 13 torr were readily measurable. The response was linear within the accuracy of the molecular beam which was 6%.

31.10.2 Apollo 17 ALSEP Mass Spectrometer

The Apollo 17 mass spectrometer was deployed on the lunar surface as one of the instruments comprising the Apollo Lunar Surface Experiments Package (ALSEP). Fig. 31.1.4 (Section 31.1.1) is a picture of the instrument as placed on the lunar surface taken by the astronaut.

Identification and the relating concentration of gas species in the lunar atmosphere were accomplished by a miniature magnetic-deflection mass spectrometer. [31.10.3] Gas molecules entering the instrument aperture were ionized by an electron bombardment ion source, collimated into a beam, and sent through a magnetic analyzer to the detector system. The ion source contained two tungsten (with 1 percent rhenium) filaments, selectable by command, as electron emitters. In the normal mode of operation, the fixed mode, the electron bombardment energy was fixed at 70 eV with the electron emission current regulated to 250 μA . This produced a sensitivity to nitrogen of 5×10^{-5} A/torr, sufficient to measure concentrations of gas species in the 1×10^{-15} torr range. An alternate mode, the cyclic mode, provides four different electron energies (70, 27, 20, and 18 eV) that are cycled by successive sweeps of the mass spectrum. Identification of gases in a complex mass spectrum is greatly aided when the spectra are taken at several different electron ionization energies. The cracking patterns of complex molecules are strongly dependent on the bombardment electron energy so that different spectra are produced for the same molecule as the electron energy changes. Also, at low energy, many gas species are eliminated from the spectrum, thus greatly simplifying the task of identifying parent molecules.

Two small heaters, consisting of ceramic blocks with embedded resistors, were mounted in the ion source, enabling its temperature to be raised to 520 K for in situ outgassing. The gas entrance was pointed upward and had a dust trap around the source region that precluded the possibility of dust falling into the source itself.

Voltage scan of the mass spectrum was accomplished by a high-voltage stepping power supply. The ion-accelerating voltage (sweep voltage) was varied in a stepwise manner through 1330 steps from 320 to 1420 V with a dwell time of 0.6 sec/step. Each step was synchronized to a main frame of the telemetry format. Ten steps of background counts (zero sweep voltage) and 10 steps of an internal calibration frequency were inserted between sweeps, making a total of 1350 steps/spectrum. The sweep time was 13.5 min.

In an alternate mode, the sweep voltage was commanded to lock on to any of the 1350 steps, enabling the instrument to monitor continuously any given mass number peak in the spectrum with a time resolution of 0.6 sec/sample. A one-step advance command was also available. The lock mode permitted high time resolution monitoring of mass peaks that were suspected to be of volcanic origin. The sweep step number, being a function of the ion-accelerating voltage, was directly related to ion mass number. Each sweep step number, in turn, was uniquely related to a main frame telemetry word. Therefore, word position in the telemetry format served as the identifier of atomic mass number in the spectrum.

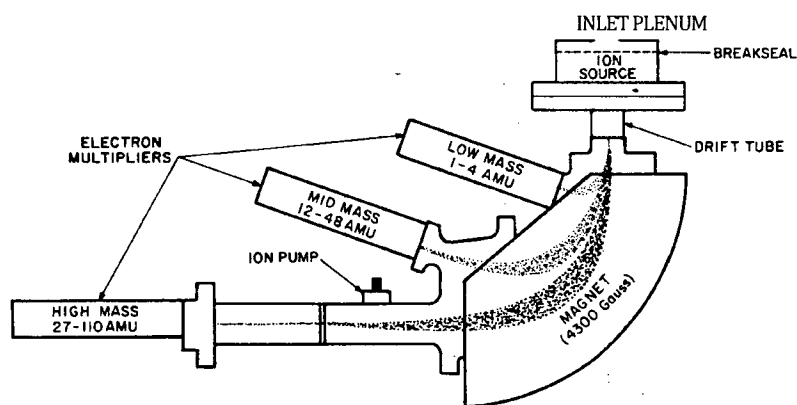

Fig. 31.10.2 Mass analyzer showing 3 ion beam trajectories through magnet.
Break seal was removed by astronaut on lunar surface.

Instrument operation was similar to that of the Lunar Orbital instrument described above. The magnetic field strength was 0.43 tesla. Three collector slits, as shown in Figure 31.10.2 enabled three mass ranges to be scanned simultaneously, namely 1 to 4, 12 to 48, and 27 to 110 Da termed low-, mid-, and high-mass ranges, respectively. The advantage of a triple-channel analyzer is that a wide mass range may be scanned by a relatively narrow voltage excursion. Also, the mid- and high-mass ranges were adjusted to allow simultaneous detection of

mass 28 and 64 ions. Therefore, in the lock mode, carbon monoxide (CO) and sulfur dioxide (SO₂), which may be candidates for volcanic gases, could be monitored simultaneously.

The detector system is analogous to that of the Apollo 15/16 instruments.

Resolution of the analyzer was set at approximately 100 for the high-mass channel at mass 82. This was defined as less than a 1-percent valley between peaks of equal amplitude at mass 82 and 83. Krypton was used to verify the resolution.

The mass spectrometer analyzer, magnet, ion source, and detectors were mounted on a base plate that bisects the instrument package in the vertical direction. These were housed in a covering. The entrance aperture, which was sealed by a ceramic cap until it was opened by the crewman, points upward, enabling the downward flux of gas molecules to be measured. To the left of the baseplate is a thermally controlled box containing the electronics. The top of the box has a mirrored surface covered by a dust cover that was commanded open after the last lunar seismic profiling experiment (LSPE) explosive package was detonated, 6 days after deployment. Fig. 31.10.2 is a drawing of the instrument package configuration.

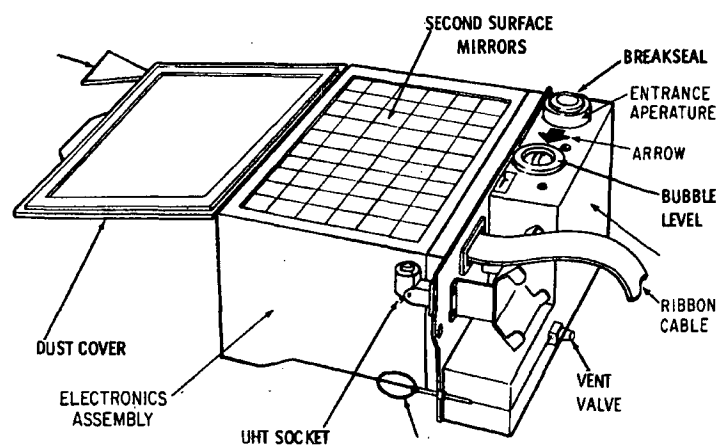

Fig. 31.10-2 Layout of packaging of LACE instrument

Calibration of the instrument was performed at the NASA Langley Research Center (LRC) in a manner similar to that of the lunar orbital mass spectrometers flown on the Apollo 15 and 16 missions (Described above in the Lunar Orbital Mass Spectrometer section).

31.11 Supporting Atmosphere Explorer C, D, and E missions

Mass spectrometers were flown on three Atmosphere Explorers (C, D, and E) for studying ion and neutral composition and reaction rates within the thermosphere as well as to provide measurements for studying the global structure and dynamics of the neutral atmosphere and ionosphere. In addition to several mass spectrometers, each spacecraft carried a retarding potential analyzer and several optical instruments.

Ion composition studies were carried out with the magnetic sector ion mass spectrometer and the Bennett RF instrument. [31.11.1] [31.11.2] These instruments are similar to those described above. The magnetic ion mass spectrometer had an expanded mass range from 1 to 90 Da utilizing 3 ion trajectories through the magnet that allowed three mass ranges to be scanned simultaneously.

Two neutral gas mass spectrometers, one an open source magnetic sector field instrument, the other a closed source instrument utilizing a hyperbolic rod quadrupole mass analyzer also were flown on the AE satellite series.

The open source instrument was a magnetic sector-field instrument similar to those used in previous rocket flights. It consists of an electron bombardment ion source, a magnetic analyzer and an electron multiplier based ion counting system. [31.11.3]

The closed source mass spectrometer functional block diagram is shown in Figure 31.11.1. [31.11.4] The sensor consisted of an inlet system, ion source, linear quadrupole analyzer, electron multiplier, and titanium sublimation pump all contained in a vacuum-tight, bakeable, stainless-steel housing. The inlet antichamber was opened to the atmosphere in orbit by fracturing a ceramic annular closure. The analyzer and filament region of the ion source were vented to the atmosphere through two rectangular openings oriented normal to the satellite velocity vector in order to achieve a lower perigee operation by maintaining a low gas density in the analyzer compared to that in the antechamber. The titanium pump was inactive in flight.

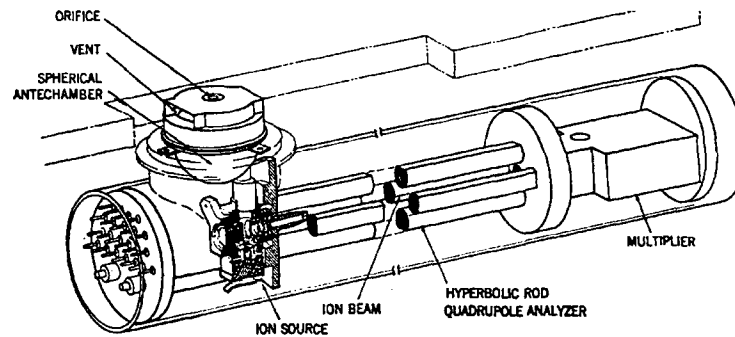

Figure 31.11.1 Closed Source Quadrupole Mass Spectrometer

Ions formed by 90 volt electron bombardment were extracted from the ionization region, focused, and accelerated into the quadrupole analyzer consisting of 4 parallel rods 15 cm long with hyperbolic surfaces and characteristic distance, R_0 , of 2.54 mm. Rf and dc voltages applied to the rods guided resonant ions (those of a chosen mass to charge ratio) down the axis of the rods to a collector. Non-resonant ions were scattered out of the beam. As resonant ions exited the quadrupole field, they passed through a weak-focusing lens and turned 90° into a 14-stage Be-Cu electron multiplier. The 90° bend eliminated the sun's photon flux coming through the entrance aperture in the ion source from activating the electron multiplier and producing a background current. The multiplier output pulse count rate was proportional to the ion chamber density of the selected gas. The mass range was 1 to 45 Da swept by incrementally stepping the rod voltages.

Mass resolution was set at 1 Da over the mass range which provided quantitative measurement of a constituent 1/1000 of the amplitude of an adjacent mass. However, the resolution was increased to about 1 in 10^4 for special studies.

To provide the dynamic range required by the altitude range of the AE, multiple integration periods (up to 16) were assigned to each measurement dependent of the relative abundance of the atmospheric species. Five automatically selected ranges of ionizing electron current provided an additional factor of 40 in dynamic range. An overall dynamic range of greater than 10^7 was achieved.

Laboratory gas calibrations were performed using hydrogen, helium, molecular and atomic oxygen, argon, nitrogen, carbon dioxide, and carbon monoxide. A special feature of this calibration system was the provision of accurate calibration pressures in helium. The use of zeolite on the liquid-helium cooled surfaces has produced an efficient helium pump behind the chamber orifice.

31.12 Pioneer Venus Mission

Large Probe Neutral Mass Spectrometer

For analysis of the Venusian atmosphere, a single focusing magnetic sector-field mass spectrometer was chosen. [31.12.1] This instrument was similar to other magnetic instruments already described. Fig. 31.12.1 is a picture of the mass spectrometer and pumping systems. Dual tungsten filaments operated at several electron energies provided redundancy. The analyzer had two mass channels covering the range from 1-16 Da (low mass range) and 15-208 Da (high mass range). Mass resolution in the high mass channel was $M/\Delta M \geq 440$ (10 percent valley) as evidence by the doublet at mass 16 shown in Fig. 31.12.1. The peaks shown are from ^{16}O and CH_4 , which have a mass difference of 1 part in 440. Resolution of the low mass channel was adequate to produce a valley of less than 1 percent between peaks at 15 and 16 Da.

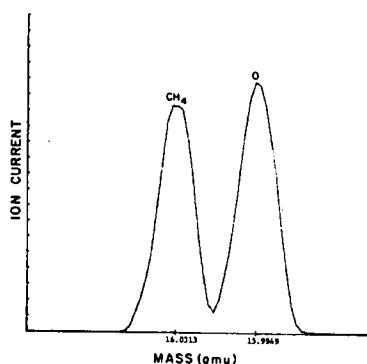

Figure 31.12.1 Mass doublet at 16 Da. Left peak is CH_4 at 16.0313 Da; right peak is O at 15.9949 Da. Valley between peaks is 9% of O peak height.

The high bandwidth of the counter system, utilizing Be-Cu 16 stage discrete dynode electron multipliers, produced a dynamic range of over 6 decades. The CO_2 peak reached a counting rate of 9 MHz in flight. The background count accumulation was typically zero per integration period of 235 ms. Scanning of the mass spectrum occurred by stepping the ion acceleration high voltage to successive peak tops under the control of a microprocessor, an Intel 4-bit processor. A preset table of mass numbers including mass defects in the microprocessor defined the voltages for the selected mass numbers. The complete spectrum, consisting of 236 mass peak positions, was scanned at the rate of 4 samples per second in 59 s. A noble gas enrichment cell, the IRMC, was included in the instrument package to collect

an atmospheric sample just after initiation of the instrument operation, purge the sample of CO₂ and later (just before parachute jettison) introduce the sample into the mass spectrometer for measurement of the isotopic ratios of the enriched inert gases remaining in the cell.

Calibration of the flight instrument was performed using a high pressure, high temperature chamber, called the Venus Atmosphere Simulator, capable of reproducing the Venus descent profile of temperature and pressure down to the surface conditions (730 K and 90 Atm).

Bus Neutral Gas Mass Spectrometer

The Pioneer Venus bus neutral gas mass spectrometer (BNMS) was designed to measure the number densities of neutral constituents in the Venus exosphere and thermosphere during its descent through the Venus upper atmosphere aboard the NASA Pioneer Venus multiprobe. [31.12.2] The BNMS sensor was a double-focusing magnetic deflection mass spectrometer. During the Venus entry the semi-open ion source was exposed directly to the influx of ambient constituents. Ionization of the neutral particles was achieved by a dual filament standard electron impact source using 56-eV electrons at an emission current of 100 microamps

Due to the bus entry velocity of 11 km/s the ambient particles of molecular mass M entered the ion source with a kinetic energy of about $0.69 M$ eV. Thus CO₂ molecules approached the BNMS with a ram energy of 30 eV. Most particles were ionized after they had been thermalized in the ion source by reflections at the walls. Only a very small portion was ionized having their original ram energy. This energy difference could be used to differentiate between the thermalized and flythrough particles by operating the ion source in the normal and the so-called flythrough modes [31.12.3].

The magnetic analyzer (MA) consisted of an Alnico 700 magnet with a flux density of 0.5 T. and ion trajectory, R_1 , of 58.9 mm. Three collector slits covering the mass ranges 1-3, 4-8, and 12-46 Da. allowed simultaneous sampling of mass numbers 1 and 14; 2 and 28; 4 and 22; 8 and 44. The dynamic range of the ion counting collector system was extended via an electrometer amplifier connected to a grid in front of the spiraltron electron multiplier. There was a one order of magnitude overlap in the measurement ranges of the multiplier and electrometer. The principle mode of analyzer operation was peak stepping with a basic sampling time of 0.1 s per mass peak. The electrometer output signals were

digitized into 10-bit words including 2 bits for range information. Operating power consumption was 4.6 W.

Bus Ion Mass Spectrometer and Orbiter Ion Mass Spectrometer

Bennett radio frequency ion mass spectrometers on the Pioneer Venus Bus (BIMS) and Orbiter (OIMS) were identical. [31.12.4] The instrument design and operational characteristics were similar to those of ion spectrometers flown on previous missions, including those on the Atmosphere Explorer-C and -E spacecraft [31.11.2]. The analyzer orifice was oriented in the direction of spacecraft motion to ensure a relatively small angle of attack throughout the periapsis pass to eliminate spin modulation of the ion currents.

A unique feature incorporated in the BIMS and OIMS instruments was the explore/adapt logic sequence for regulating the consecutive measurements of individual ion species. This was accomplished in two steps: 1) periodic exploration of 16 preselected ion species, and 2) adaptive sequencing of repetitive ion measurements according to the relative significance of ion currents detected during the exploratory cycle. The explore/ adapt sequence thereby provides a spatial resolution of measurements inversely proportional to the number of ions encountered and thus automatically adjusts the measurement sequence so that information returned is optimized relative to the conditions encountered during the mission.

Orbiter Neutral Gas Mass Spectrometer

The Pioneer Venus Orbiter mass spectrometer was a linear quadrupole instrument with a unique ion source that was enclosed, but exposed directly to the ambient atmosphere through a small aperture. [31.12.5] An ion repeller grid just inside the aperture was positively biased (approximately 40 V) to reject positive ions. Grids enclosing the ionization region were electrically biased so that all ions produced were drawn through a retarding grid into the quadrupole analyzer. The grid assembly functioned as a miniaturized retarding potential analyzer for analysis of direct streaming neutral particles.

The ion source could be operated either as a closed source or open source. A weak angle of attack dependence, (a cosine function) made the closed source mode useful for measurements at large angles of attack. It also provided a sensitivity enhancement over the open mode.

In the open source mode, the potentials of the source grids allowed free streaming particles to enter the retarding field that discriminated between those with relatively large kinetic energy and those that were thermalized to the ion source region temperature. The ions produced from thermalized surface reflected particles were rejected while those with enough kinetic energy to overcome the retarding field were passed into the quadrupole mass analyzer. The sensitivity was determined by laboratory calibration using high velocity molecular beams and in flight by comparing measurements made of nonreactive species in both operating modes.

The ion source was covered by a metal-ceramic break-off cap that was removed by a pyrotechnic actuator after orbit insertion. The quadrupole mass filter consisted of hyperbolically contoured rods 7.5 cm long with a field radius of 0.2 cm. The secondary electron multiplier was a Be-Cu 14 dynode box and grid design. The average power consumption of the instrument was 12 W. The weight of the instrument was 3.8 kg. The ion source had redundant filaments that could operate at either - 70 eV or 27 eV.

The mass peaks produced by the assembly had flat tops that permitted stepping from mass unit to unit without requiring peak searching. Three operational modes were programmed to scan individually any 8 selected mass numbers (0 to 46 Da), to scan sequentially 0 to 46 Da at unit increments (search mode) or to scan sequentially 0 to 46 Da at 1/8 Da increments (diagnostic mode). Ion counting was employed but at high signal levels where the counting system had a significant dead-time, the anode current at the multiplier was used as a measure of the ion current. The dynamic range of the instrument was greater than 10^6 .

31.13 Mars Phoenix Mass Spectrometer

Major components of the Phoenix mass spectrometer were: 1) a gas handling manifold containing a gas transfer tube from the Thermal Analyzer (TA) ovens to the MS ion source, the TA gas inlet valve and microleak, an atmospheric gas inlet valve and microleak;; 2) the magnetic sector field mass with four

electron multiplier detectors and associated electronics circuits; and 3) a small sputter-ion pump to maintain a good vacuum in the analyzer. [31.13.1]

The two inlet paths through the gas manifold admitted gases into the ion source of the instrument. These were (a) a direct path through the transfer tube from the Thermal Evolved Gas Analyzer (TEGA) furnace and (b) a direct path from the atmosphere through a short transfer tube that fed gas into the atmosphere inlet valve on the ion source. The entire manifold and transfer tubes were heated to 35 °C to keep water vapor and other volatiles from freezing onto the walls

The microleaks that control the rate of gas flows into the MS ion source consisted of a bundle of capillary glass tubes drawn out to reduce their diameters so that the conductance of the bundle was about 1×10^{-5} cc/sec. for the TA inlet and somewhat larger for the atmosphere inlet. Gasses admitted to the ion source flowed out of it through the ion object slit (conductance 5 cc/sec.) into the mass analyzer vacuum chamber maintaining an equilibrium pressure of 8×10^{-6} mbar. A sputter ion pump maintained an analyzer pressure of less than 1×10^{-7} mbar.

The mass spectrometer ion source was a Nier type with redundant filaments. Two emission currents (25 μ A and 200 μ A) and four electron energies (90eV, 37eV, 27eV and 23eV) were controlled by a microprocessor. The magnetic analyzer had four channels that covered the mass ranges 0.7-4, 7-35, 14-70 and 28-140 Da. The mass resolution for the highest mass range was set at 140 (M/ Δ M). The mass resolution of the other channels was proportionally reduced. Ion counting detectors were employed.

The maximum ion counting rate was 2 megahertz. The preamp frequency was 12 megahertz. The high sensitivity added a factor of 8, for a dynamic range of 1.6×10^7 . By summing the counting rates for 100 measurements, a gas at the 100 ppb mixing ratio level (partial pressure of 1×10^{-12} mbar) could be measured at a statistical precision of 10%; at 10 ppb (partial pressure of 1×10^{-13} mbar) the precision is 30%. The realized sensitivity depended on the residual peak amplitude at the particular m/z of interest.

The NeBFe magnet of had a field strength of 0.65T with a mass of only 500 grams. Mass was a critical parameter in the design of the instrument.

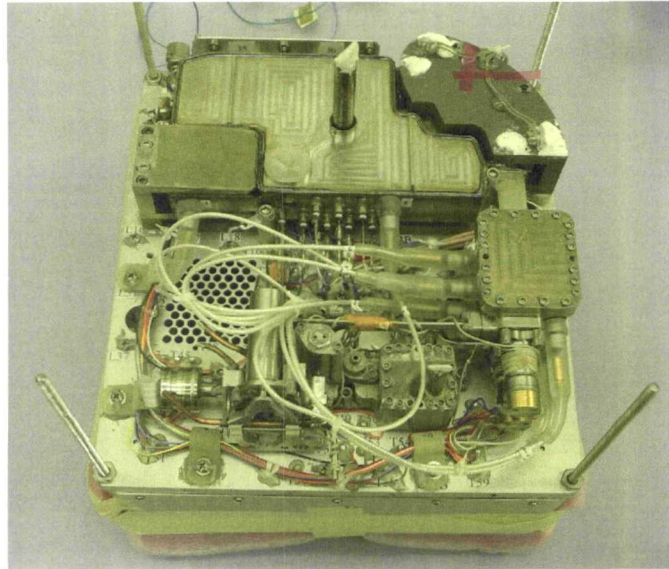

Figure 31.13.1 Complete mass spectrometer package

Figure 31.13.1 shows the complete mass spectrometer package. The mass analyzer is at the top with the ion source at the right. The high vacuum valves protrude down ward from the ion source housing. The gas manifold lies across the bottom.

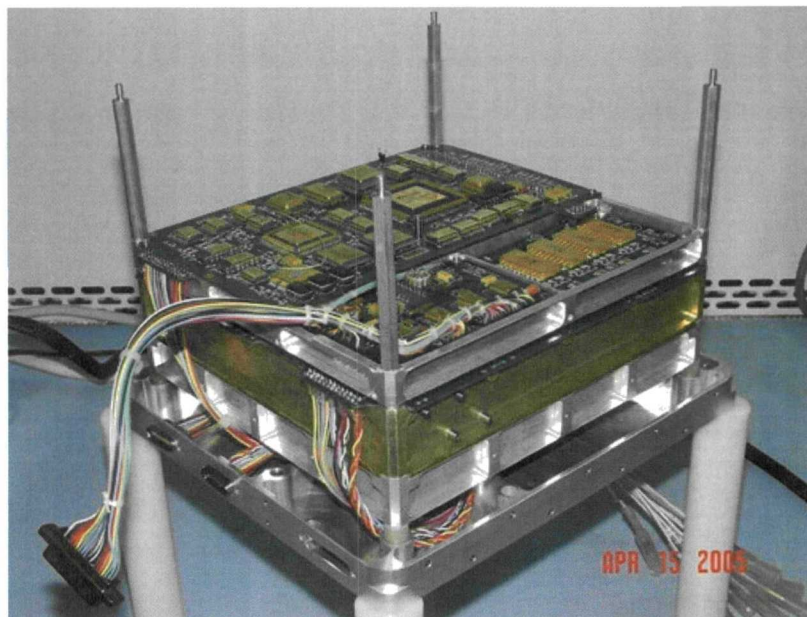

Figure 31.13.2 Picture of the TEGA electronics assembly.

The electronics subsystem consists of three modules, the Processor Module, Low Voltage Module and High Voltage Module mounted on top of the instrument support plate as shown in Figure 31.13.2. The electronics were functionally similar to those of previously flown mass spectrometers. The processor

module consisted of a dedicated 80C196KD microprocessor, FPGA, memory, bus drivers and associated circuitry required to control and monitor the instrument functions as well as to store accumulated data.

The high voltage module provided the precision ion accelerating voltage (200 to 2000V) stepping power supply for the ion source that was controlled by a 16 bit D/A converter. For standard stepping, the precision of the output voltage was better than 14 bits after the 5 ms settling interval. The high voltage module also contained the filament emission circuitry plus electron multiplier and ion pump power supplies.

For an instrument that is to operate on the surface of Mars, all high voltages must employ special electrostatic shields to prevent corona discharges in the 8 to 10 mb atmospheric pressure environment. Each high voltage module employed an encapsulated Faraday Shield to prevent high voltage breakdown. However, the emission control section used a special shielded enclosure without encapsulation. High voltage connections to the analyzer were also shielded using special vacuum feedthrus with shielded cables and boots that sealed each connector to its respective vacuum feedthru.

Two operating modes were available. One, the sweep mode, consisted of sweeping the ion accelerating voltage across the entire mass range over the 4 channels to provide a broad brush look at the composition of the gas sample. The other mode, the hops mode, involved hopping from peak top to peak top. On a given peak, 7 measurements of counting rate were made while stepping over the top of the peak. The amplitude of the peak was determined by fitting a curve to the 7 data points.

The mass spectrometer mass was 5.7 kg, power was .13 watts, and volume was 24x23x18 cm.

31.14 Reference Information

31.1.1 Aerojet Aerobee Rocket, Fact Sheets of the National Museum of the US Air Force, Web Site.

31.1.2 Radiofrequency Mass Spectrometer, Bennett, W. H., J. Applied Phys. 21, 143-149, 1950.

31.1.3 Small General Purpose Double-Focusing Mass Spectrometer, Nier, A. O., Rev. Sci. Instr., 31 2217-1132, 1960.

31.1.4 Neutral Composition of the Atmosphere in the 100 – 200 Kilometer Range, Nier, A. O., J. H. Hoffman, C. Y. Johnson and J. C. Holmes, J. Geophys. Res., 69, No. 5, 979-989. 1064.

31.1.5 Neutral Constituents of the Upper Atmosphere: Minor Peaks observed in a Mass Spectrometer, Nier, A. O., J. H. Hoffman, C. Y. Johnson and J. C. Holmes, J. Geophys. Res., 69, No. 21, 4629-4636, 1064.

31.1.6 Ion Mass Spectrometer on Explorer XXXI Satellite, Hoffman, J. H. Proceedings of the IEEE 57, No. 6, 1063-1067, 1969.

31.1.7 Daytime Midlatitude Ion Composition Measurements, Hoffman, J. H., C. Y. Johnson, Holmes, J. C. and Young, J. M., J. Geophys. Res., 74, No. 26, 6281-6290, 1969

31.1.8 Ion Concentrations and fluxes in the Polar Regions During Magnetically Quiet Times, Hoffman, J. H. and W. H. Dodson, J. Geophys. Res. 85, No A2, 626-632, 1980.

31.1.9 A Mass Spectrometric Determination of the Composition of the Nighttime Topside Ionosphere Hoffman, J. H., J. Geophys. Res., 72, No. 7, 1883-1888, 1967.

31.1.10 Lunar Orbital Mass Spectrometer Experiment, Hoffman, J. H. Hodges, R. R. and Evans, D. E. , Proceedings of the Third Lunar Science Conference, Supplement 3, Geochimica et Cosmochimica Acta, 3, 2205-2216, 1972

31.1.11. Lunar Atmospheric Composition Results from Apollo 17, J. H. Hoffman, R. R. Hodges, Jr. F. S. Johnson and D. E. Evans, Proc. of the Fourth Lunar Science Conference, Supplement 4, Geochimica et Cosmochimica Acta, 3, 2865-2875, 1973.

31.1.12 The Lunar Atmosphere, Hodges, Jr., R. R., J. H. Hoffman, and F. S. Johnson, Icarus, 21, 415-426, 1974.

31.1.13 The Atmospheric Explorer Mission, Dalgarno, A, W. B. Hanson, N. W. Spenser, E. R. Schmerling, Radio Science, 8, No. 4. 263-266, 1973.

31.1.14 An encounter with Venus, Colon, L., Science, 203, 23 February, 743-744, 1979.

31.1.15 Venera Mass Spectrometer experiment, Istomin, V. G. , K. V. Grechnev, V. K. Kochnev, V. A. Pavlenko, L. N. Ozerov, andv. G. Klimovitsky,h. 5, 4, 1979.

31.1.16 Composition and Structure of the Venus Atmosphere, Hoffman, J. H., R. R. Hodges, M. B. McElroy, T. M. Donahue, M. Koplín, Science, 205, 6, July, 49-51, 1979.

31.1.17 Venus Was Wet: A Measurement of the Ratin of Deuterium to Hydrogen, Donahue, T. M., J. H. hoffman, R. R. Hodges, Jr., and A. J. Watson, Science, 216, 7 May 1082, 630-633.

31.1.8 Measurements of the Venus Lower Atmosphere Composition: A comparison of Results, Hoffman, J. H., V. I. Oyama, U. von Zahn, J. Geophys. Res. 85, No. A 13, 7871-7881 1980.

31.1.19 Venus Upper Atmosphere Neutral Composition, Niemann, H. B., R. E. Hartle, W. T. Kasprzak, N. W. Spenser, S. H. Way, D. M. Hunten, and G. R. Carignan, Science, 203, 23 February, 770-772, 1979.

31.1.20 In Situ Gas and Ion Measurements at Comet Halley, Krankowsky, D, P. Lammerzähl, L. Herrwerth, J. Woweries, P. Eberhardt, U. Dolder, U. Herrmann, W. Schulte, J. J. Berthelier, J. H. Illiano, R. R. hodges and J. H. Hoffman, Nature, 321, No 6067, 326-329, 1986.

31.1.21 An overview of the descent and landing of the Huygens probe on Titan ·
Lebreton, Jean-Pierre; Witasse, Olivier; Sollazzo, Claudio; Blancquaert, Thierry; Couzin, Patrice; Schipper, Anne-Marie; Jones, Jeremy B.; Matson, Dennis L.; Gurvits, Leonid I.; Atkinson, David H.; Kazeminejad, Bobby; Pérez-Ayúcar, Miguel. Nature, 438,. 758-764. 2005.

31.1.22 The abundances of constituents of Titan's atmosphere from the GCMS instrument on the Huygens probe, H. B. Niemann, S. K. Atreya, S. J. Bauer, G. R. Carignan, J. E. Demick, R. L. Frost, D. Gautier, J. A. Haberman, D. N. Harpold, D. M. Hunten, G. Israel, J. I. Lunine, W. T. Kasprzak, T. C. Owen, M. Paulkovich, F. Raulin, E. Raaen, S. H. Way, Nature **438**: 779–784 2005.

31.1.23 Composition and Structure of the Martian Atmosphere: Preliminary Results from Viking 1
Nier, A. O, W. B. Hanson, A. Sieff, M. B. McElroy, N. W. Spenser, R. J. Duckett, T. C. D. Knight, and W. S. Cook, Science 27 August 1976: 786-788.

31.1.24 Composition of the Atmosphere at the Surface of Mars: Detection of Argon-36 and Preliminary Analysis, Owen, T and K. Biemann, Science 27 August 1976: 801-803.

31.1.25 Water at the Phoenix Landig Site, P.H. Smith, L.K. Tamppari, R.E. Arvidson, D. Bass, D. Blaney, W.V. Boynton, A. Carswell, D.C. Catling, B.C. Clark, T. Duck, E. DeJong, D. Fisher, W. Goetz, H.P. Gunnlaugsson, M.H. Hecht, V. Hipkin, J. Hoffman, S.F. Hviid, H.U. Keller, S.P. Kounaves, C.F. Lange, M. Lemmon, M.B. Madsen, M. Malin, W.J. Markiewicz, J. Marshall, C.P. McKay, M.T. Mellon, D.W. Ming, R.V. Morris, N. Renno, W.T. Pike, U. Staufe, C. Stoker, P. Taylor, J. Whiteway, A.P. Zent, Science, 3 July, 58-61, 2009.

- 31.1.26 Evidence for Calcium Carbonate at the Mars Phoenix Landing Site, Boynton, W. V., W. Ming, S. P. Kounaves, S. M. M. Young, R. E. Arvidson, M. H. Hecht, J Hoffman, P. B. Niles, D. K. Hamara, R. C. Quinn, P. H. Smith, B. Sutter, D. C. Catling, R. V. Morris, *Science*, 3 July, 61-64, 2009.
- 31.1.2.1 Johnston, R.S. and Dietlein, L. (ed), *Biomedical Results of Skylab*, NASA SP377, NASA Scientific and Technical Information Office, Washington, D.C., 1977., Chapter 36.
- 31.1.2.2 Michel, E.L., Rummel, J.A., and Sawin, C.F. “Skylab experiment M-171 ‘Metabolic Activity’- results of the first manned mission”, *Acta Astronautica* Vol2, 1975, pp. 351-365.
- 31.1.2.3 Johnston, R.S., Dietlein, L.F., and Berry, C.A. (ed), *Biomedical Results of Apollo*, NASA SP-368, NASA Scientific and Technical Information Office, Washington, D.C., 1975, Section II, Chapter 7.
- 31.1.2.4 Perry, C.L., “Metabolic Analyzer”, NASA Technical Memorandum TM X-64797, June 1971. Pp 1-2.
- 31.1.2.5 op. cit. Michel p. 353.
- 31.1.2.6 Lehotsky, R., “A Mass Spectrometer Sensor System for Metabolic Analysis and Atmospheric Monitoring on Skylab and Future Manned Spacecraft”, *Proceedings of the 21st Annual Conference on Mass Spectrometry and Allied Topics*, San Francisco, CA., May 20-25, 1973, pp 403-411.
- 31.1.2.7 “Life Sciences Flight Experiment Program: Life Sciences Laboratory Equipment (LSLE) Descriptions”, Document # JSC-16254-G, May 1984. pp. 18-21.
- 31.1.2.8 http://lsda.jsc.nasa.gov/scripts/hardware/hardw.cfm?hardware_id=175
- 31.1.2.9 Samonski jr., F.H., “Technical History of the Environmental Control for Project Mercury”, NASA Technical Note TN D-4126, October 1967.
- 31.1.2.10 “Flammability, Odor, Offgassing, and Compatibility Requirements and Test Procedures for Materials in Environments that Support Combustion”, NASA: NHB 8060.1C (latest version), April 1991.
- 31.1.2.11 Nelson, N. (Chairman, Panel on Air Standards for Manned Space Flight), “Atmospheric Contaminants in Spacecraft”, National Academy of Sciences, 1968.

- 31.1.2.12 Wands, R.C. (Director, Advisory Center on Toxicology), "The Relationship of NASA Occupational Medicine and Environmental Health with the Advisory Center of Toxicology, National Research Council, NAS, October 1969.
- 31.1.2.13 "Spacecraft maximum Allowable Concentrations for Airborne Contaminants", NASA document: JSC 20584 (latest version).
- 31.1.2.14 "Guidelines for Developing Spacecraft Maximum Allowable Concentrations for Space Station Contaminants", National Academy Press, Washington, D.C., 1996.
- 31.1.2.15 "Spacecraft Maximum Allowable Concentrations for Selected Airborne Contaminants", Volume 1, National Academy Press, Washington, D.C., 1994.
- 31.1.2.16 "Spacecraft Maximum Allowable Concentrations for Selected Airborne Contaminants", Volume 2, National Academy Press, Washington, D.C., 1996.
- 31.1.2.17 "Spacecraft Maximum Allowable Concentrations for Selected Airborne Contaminants", Volume 3, National Academy Press, Washington, D.C., 1996.
- 31.1.2.18 "Spacecraft Maximum Allowable Concentrations for Selected Airborne Contaminants", Volume 4, National Academy Press, Washington, D.C., 2000.
- 31.1.2.19 "Spacecraft Maximum Allowable Concentrations for Selected Airborne Contaminants", Volume 5, National Academy Press, Washington, D.C., 2008.
- 31.1.2.20 *op. cit.* Samonski, jr.
- 31.1.2.21 *op. cit.* Johnson, R.S., Biomedical Results of Apollo
- 31.1.2.22 Gohlke, R.S. and McLafferty, F.W., "Early Gas Chromatography/Mass Spectrometry", *J. Am. Soc. Mass Spectrom.*, 1993, 4, 367-371.
- 31.1.2.23 Parker, jr., J.F., West, V. (editors) Bioastronautics Data Book, NASA-3006, 2nd edition, 1973.
- 31.1.2.24 "The Proceedings of the Skylab Life Sciences Symposium, Volume 1", Lyndon B. Johnson Space Center, August 1974, JSC-09275 or NASA Technical Memorandum TM X-58154, November 1974.
- 31.1.2.25 Liebich, H., Bertsch, W., Zlatkis, A., Schneider, H., "Volatile Organic Components in the Skylab 4 Spacecraft Atmosphere," *Aviation, Space, and Environmental Medicine*, August 1975, pp.1002-1006.
- 31.1.2.26 Galen, T.J., Solid Sorbent Air Sampler United States patent #4584887, 1986.

- 31.1.2.27 Limero, T., “Solid Sorbent Air Sampler for the Characterization of Contaminants in Spacecraft Atmospheres”, Proceedings of 1990 EPA/AW&MA International Symposium: Measurement of Toxic and Related Air Pollutants, Raleigh, N.C., 1990.
- 31.1.2.28 EPA Air Toxic Monitoring methods (TO-14a and TO-15)
<http://www.epa.gov/ttnamti1/airtox.html>
- 31.1.2.29 *ibid*, EPA Air Toxic Monitoring methods (TO-1, TO-14a, TO-15, and TO-17)
- 31.1.2.30 Palmer, P.T., Wong, C.M., “Development of Ion Trap Mass Spectrometric Methods to Monitor Air Quality for Life Support Applicationsm,” 23rd International Conference on Environmental Systems, Technical Paper # 932206, Colorado Springs, CO., July 1993.
- 31.1.2.31 Palmer, P.T. and Limero, T.F., Mass Spectrometry in Space.
- 31.1.2.32 Wyatt, J., http://www.navy.mil/navydata/cno/n87/usw/issue_10/breathe.html.
- 31.1.2.33 Daley, T., “Keynote Address: The Evolution of Submarine Air Monitoring and Air Purification in the US Navy”, Submarine Air Monitoring and Air Purification (SAMAP) conference proceedings, Amsterdam, NE, 2005.
- 31.1.2.34 Steiner, G, Edeen, M., and Ransom, E., “On Orbit Performance of the Major Constituent Analyzer” 32nd International Conference on Environmental Systems, Technical Paper 2002-01-2404, San Antonio, TX., 2002.
- 31.1.2.35 *ibid* Steiner
- 31.1.2.36 Eiceman, G.A., et.al., “Ion Mobility Spectrometry of Hydrazine, Monomethylhydrazine, and Ammonia in Air with 5-Nonanone Reagent Gas, *Anal. Chem.*, 1993, **65**, pp1696-1702.
- 31.1.2.37 Limero, T.F., et.al., “A Volatile Organic Analyzer for Space Station: Description and Evaluation of a Gas Chromatography/Ion Mobility Spectrometer”, 22nd International Conference on Environmental Systems, Technical Paper 921385, Seattle, WA., 1992.
- 31.1.2.38 Searching for Life On Mars: The Development of the Viking Gas Chromatograph Mass Spectrometer (GC/MS) http://www.nasa.gov/pdf/384151main_Viking_GCMS_case_study.pdf
- 31.1.2.39 Brittain, A., Bass, P., Breach, J., and Limero, T., “Instrumentation for Analyzing Volatile Organic Compounds in Inhabited Enclosed Environments”, 30th International Conference on Environmental Systems, Technical Paper 2000-01-2434, Toulouse, FR., 2000.
- 31.1.2.40 Limero, T., Reese, E., Trowbridge, J., Hohman, R., James, J.T., “The Volatile Organic Analyzer (VOA) Aboard the International Space Station”, b

- 31.1.2.41 Limero, T., “Revalidation of the Volatile Organic Analyzer Following a Major On Orbit Maintenance Activity,” 37th International Conference on Environmental Systems, Technical Paper 2007-01-3220, Chicago, IL., 2007.
- 31.1.2.42 Limero, T. and Reese, E., “First Operational Use of the ISS-VOA in A Potential Contingency Event”, International Journal for Ion Mobility Spectrometry, 5(2002)3, pp. 27-30.
- 31.1.2.43 Limero, T., “Volatile Organic Analyzer (VOA) in 2006: Repair, Revalidation, and Restart of Elektron Event”, International Society for Ion Mobility Spectrometry (ISIMS) Conference Proceedings, 2007.
- 31.1.2.44 Limero, T., Cheng, P., and Boyd, J., “Evaluation of Gas Chromatography-Differential Mobility Spectrometry for Measurement of Air Contaminants in Spacecraft”, 36th International Conference on Environmental Systems, Technical Paper 2006-01-2153, Norfolk, VA., 2006.
- 31.1.2.45 <http://www.sionex.com/products/downloads/SIONEX-Introduces-the-microAnalyzer.pdf>
- 31.1.2.46 Chutjian, A., et.al, “Overview of the Vehicle Cabin Atmosphere Monitor, a Miniature Gas Chromatography/Mass Spectrometer for Trace Contaminant Monitoring on the ISS and CEV,” 37th International Conference on Environmental Systems, Technical Paper 2007-01-3150, Chicago, IL., 2007.
- 31.1.2.47 Chutjian, A., Darrach, M., Bornstein, B., Croonquist, A., and Edgu-Fry, E., “Results from the Vehicle Cabin Atmosphere Monitor: A Miniature Gas Chromatograph/Mass Spectrometer for Trace Contamination Monitoring on the ISS and Orion,” 38th International Conference on Environmental Systems, Technical Paper 2008-01-2045, San Francisco, CA., 2008.
- 31.1.4.1) Goodrich, W. D., “Viscous flow effects on hydrogen leaks from cracks in the Orbiter Challenger main engines”, American Institute of Aeronautics and Astronautics, Aerospace Sciences Meeting, 22nd, Reno, NV, Jan. 9-12, 1984.
- 31.1.4.2) Seymour, “STS-35 Scrub 3 Hydrogen Leak Analysis”, NASA Technical Memorandum TM-103548, **July 1991**.
- 31.1.4.3) “Hydrogen Leak Discovered on Shuttle Atlantis”, NASA Press Release 90-89, 29 June 1990.
- 31.1.4.4) “STS-73/Columbia Launch Scrub”, KSC Shuttle Status, 28 September 1995.

- 31.1.4.5) “STS-93 Mission Archive”,
http://www.nasa.gov/mission_pages/shuttle/shuttlemissions/archives/sts-93.html.
- 31.1.4.6) Harwood, W., “Oxygen leak delays shuttle Endeavour's launch”, *Spaceflight Now*, **11 November 2002**, <http://spaceflightnow.com/station/stage11a/021110scrub/>.
- 31.1.4.7) “NASA Shuttle Launch Targeted for No Earlier Than March 15”, NASA Press Release 09-059, 11 March 2009.
- 31.1.4.8) “NASA Postpones Launch of Space Shuttle Endeavour”, NASA Press Release 09-135, 13 June 2009.
- 31.1.4.9) “Fuel Leak Again Postpones Launch of Space Shuttle Endeavour”, NASA Press Release 09-138, 17 June 2009.
- 31.1.4.10) Helms, W. R.; Raby, B. A. , “A Prototype Hazardous Gas Detection system for NASA’s Space Shuttle” , 26th ASMS Conference on Mass Spectrometry and Allied Topics, St. Louis, MO, 1978, 463-465.
- 31.1.4.11) Helms, W. R. “History, Design, and Performance of the Space Shuttle Hazardous Gas Detection System,” Space Shuttle Technical Conference, Houston, TX, June, 1983, NASA Conference Publication 2342, Part 1, 573-580.
- 31.1.4.12) Bill Helms, personal communication.
- 31.1.4.13) Wyatt, J.R., “Development of a Small Magnetic Mass Spectrometer for Atmosphere Analysis/Process Control”, *Int. J. Mass Spec. Ion Process*, **1984**, 60, 289-297.
- 31.1.4.14) Griffin, T. P.; Breznik, G. S.; Mizell, C. A.; Helms, W. R.; Naylor, G. R.; Haskell, W. D. “A Fully Redundant On-Line Mass Spectrometer System Used To Monitor Cryogenic Fuel Leaks on the Space Shuttle” *Trends Anal. Chem.*, **2002**, 21(8), 488-497.
- 31.2.1) “Introduction to Helium Mass Spectrometer Leak Detection”, Varian Vacuum; 2nd edition (1995).
- 31.2.2) Orvis M. Knarr, “Industrial Gaseous Leak Detection Manual” McGraw-Hill Professional Publishing (December 1, 1997)
- 31.2.3) Luke Hinkle, “If they don’t control Mass Flow, Why Do We call Them ‘Mass Flow Controllers?’”, *Vac. Tech and Coating* (Sept, **2007**) GD&D, pp 4-6.

- 31.3.1) Griffin, T. P.; Breznik, G. S.; Mizell, C. A.; Helms, W. R.; Naylor, G. R.; Haskell, W. D. "A Fully Redundant On-Line Mass Spectrometer System Used To Monitor Cryogenic Fuel Leaks on the Space Shuttle" *Trends Anal. Chem.*, **2002**, 21(8), 488-497.
- 31.3.2) Dawson, P. H. *Quadrupole Mass Spectrometry and its Applications*. Elsevier: Amsterdam, **1976**.
- 31.3.3) G. C. Rhoderick, W. J. Thorn, W. R. Miller, F. R. Guenther, E. J. Gore and T. O. Fish, "Gas Standards Development in Support of NASA's Sensor Calibration Program around the Space Shuttle" *Anal. Chem.*, **2009**, 81 (10), 3809–3815.
- 31.3.4) STS-113, Personal Communications with Hazardous Gas Detection Launch Team, 2002.
- 31.5.1) Johnston, R.S., Dietlein, L.F., and Berry, C.A. (ed), Biomedical Results of Apollo, NASA SP-368, NASA Scientific and Technical Information Office, Washington, D.C., 1975, Section II, Chapter 7.
- 31.5.2) Cardus, D. "Effects of 10 days recumbency on the response to the bicycle ergometer test", *Aerospace Med.*, 37:993-999, **1966**.
- 31.5.3) Hyatt, K.H., Kamenetsky, L.G., and Smith, W. M., "Extravascular dehydration as an etiologic factor in post-recumbency orthostatism", *Aerospace Med.*, 40: 644-650, **1969**.
- 31.5.4) Miller, P.B., Johnson, R.L., and Lamb, L.E. "Effects of moderate physical exercise during four weeks of bed rest on circulatory functions in man", *Aerospace Med.*, 36:1077-1082, **1965**.
- 31.5.5) Saltin, B., Blomquist, G., Mitchell, J.H., Johnson Jr, R. L., Wildenthal, K., and Champman, C.B., "Response to exercise after bed rest and after training. A longitudinal study of adaptive changes in oxygen transport and body composition", *Circulation*, 38:1-78, **1968**.
- 31.5.6) *op. cit.* Johnston, Biomedical Results of Apollo Section III.
- 31.5.7) Johnston, R.S., and Dietlein, L.F(ed), Biomedical Results of Skylab, NASA SP377, NASA Scientific and Technical Information Office, Washington, D.C., 1977.
- 31.5.8) *Ibid*, Johnston, Biomedical Results of Skylab, Chapter 36.

- 31.5.9) Sawin, C.F., Taylor, G.R., and Smith, W., Extended Duration Orbiter Medical Project: Final Report 1989-1995, NASA/SP-1999-534, 1999.
- 31.5.10) *ibid*, Sawin, Section 3.
- 31.5.11) “Life Sciences Flight Experiment Program: Life Sciences Laboratory Equipment (LSLE) Descriptions”, Document # JSC-16254-G, May 1984. pp. 18-21.
- 31.5.12) Personal communications (Statement of Work for Gas Analyzer System for Metabolic Analysis Physiology).
- 31.5.13) West, J., Human Experiments on Spacelab SLS-1, Pubmed.gov, Volume 34, Issue 1, 1991.
- 31.5.14) Huff, W. Spacelab Life Sciences-2, PubMed.gov, Vol1, Issue 1, 1994, pp.3-1.
- 31.5.15) Cooke, W.H., et.al., “Nine Months in space: effects on human autonomic cardiovascular regulation”, *J. Appl Physiol*, Vol 89, **2000**, pp.1039-1045.
- 31.5.16) http://www.nasa.gov/centers/marshall/pdf/115941main_hrf.pdf.
- 31.5.17) http://lsda.jsc.nasa.gov/scripts/hardware/hardconfig.cfm?hardware_index=1601&exp_index=0.
- 31.5.18) Personal communications: William Niu (Hamilton-Sunstrand).
- 31.5.19) “Life Sciences Flight Experiment Program: Life Sciences Laboratory Equipment (LSLE) Descriptions”, Document # JSC-16254-G, May 1984. pp. 18-21.
- 31.5.20) Lehotsky, R., “A Mass Spectrometer Sensor System for Metabolic Analysis and Atmospheric Monitoring on Skylab and Future Manned Spacecraft”, Proceedings of the 21st Annual Conference on Mass Spectrometry and Allied Topics, San Francisco, CA., May 20-25, 1973, pp 403-411.
- 31.5.21) Michel, E.L., Rummel, J.A., and Sawin, C.F. “Skylab experiment M-171 ‘Metabolic Activity’-results of the first manned mission”, *Acta Astronautica* Vol2, 1975, pp. 351-365.
- 31.5.22) Personal communications: Presentation (GAMS SLS-1 Anomalies) to SLS-1 Payload Oversight Committee.
- 31.5.23) http://lsda.jsc.nasa.gov/scripts/hardware/hardw.cfm?hardware_id=175.
- 31.5.24) <http://www1.nasa.gov/centers/marshall/news/background/facts/hrf.html>.
- 31.5.25) http://lsda.jsc.nasa.gov/scripts/experiment/exper.cfm?exp_index=903.
- 31.5.26) Robinson, J., Rhatigan, J., and Baumann, D, “International Space Station Research Summary Through Expedition 10”, NASA/TP-2006-21346.
- 31.5.27) http://www.nasa.gov/mission_pages/station/science/experiments/PFS.html.

- 31.5.28) Prisk, G., Elliott, A., and West, J., “Sustained microgravity reduces the human ventilator response to hypoxia but not to hypercapnia”, *J. Appl Physiol.*, 88:1421-1430, 2000.
- 31.5.29) Prisk, G., Fine, J., Cooper, T., West, J., “Vital capacity, respiratory muscle strength, and pulmonary gas exchange during long-duration exposure to microgravity”, *J. Appl Physiol.*, 101:439-447, 2006.

- 31.6.1) Flammability, Odor, Offgassing, and Compatibility Requirements and Test Procedures for Materials in Environments that Support Combustion”, NASA: NHB 8060.1C (latest version), April 1991.
- 31.6.2) Spacecraft Maximum Allowable Concentrations for Airborne Contaminants”, NASA document: JSC 20584 (latest version).
- 31.6.3) Reuter, J., Reysa, R., “International Space Station Environmental Control and Life Support System Status: 2000-2001”, 31st International Conference on Environmental Systems Technical Paper 2001-01-2386, Orlando, FL., 2001.
- 31.6.4) EPA Air Toxic Monitoring methods (TO-15r), <http://www.epa.gov/ttnamti1/airtox.html>
- 31.6.5) Toxicology Laboratory ISO9001 Work Instruction
- 31.6.6) EPA Air Toxic Monitoring methods (TO-14a and TO-15)
<http://www.epa.gov/ttnamti1/airtox.html>
- 31.6.7) Palmer, P. and Limero, T., “Mass spectrometry in U.S. space program: past, present, and future” Journal of the American Society of Mass Spectrometry, Volume 12, Issue 6, June 2001, pp. 656-675
- 31.6.8) James, J., “A History of Space Toxicology Mishaps: Lessons Learned and Risk Management”, 39th International Conference on Environmental Systems, Technical Paper 2009-01-2591, Savannah, GA, 2009.
- 31.7.1) Rotheram, M.A., “Atmospheric Composition Monitor Assembly for Space Station Freedom Environmental Control and Life Support System,” SAE Technical Paper Series 891451, 19th Intersociety Conference on Environmental Systems, San Diego, CA., 1989
- 31.7.2) Torres, D.A., Cole, A., and Hiss, J., “Stand Alone Major Constituents Analyzer Flight Design”, SAE Technical Paper Series 94`503, 24th International Conference on Environmental Systems, Friedrichshafen, Germany, 1994
- 31.7.3) Coleman, M. reference

- 31.7.4) Niu, W., Rotheram, M.A., Dencker, W., and Davidson, L. "The development of an Atmospheric Composition Monitor for the Environmental Control and Life Support System," SAE Technical Paper Series 921149, 22nd International Conference on Environmental Systems, Seattle, WA., 1992
- 31.7.5) McHard, R., Reysa, R., Granaham, J., "Accuracy Assessment of the Major Constituent Analyzer", 35th International Conference Environmental Systems, Technical Paper 2005-01-2893.
- 31.7.6) Steiner, G., Edeen, M., Ransom, E., and Gentry, G., "On-Orbit Performance of the Major Constituent Analyzer", 32nd International Conference on Environmental Systems, Technical Paper 2002-01-2404, San Antonio, TX., 2002.
- 31.7.7) Gentry, G., Reysa, R., and Lewis, J., "International Space Station (ISS) Environmental Control and Life Support (ECLS) System Equipment Failures, Causes, and Solutions February 2001-February 2002", 32nd International Conference on Environmental Systems, Technical Paper 2002-01-2495, San Antonio, TX., 2002.
- 31.7.8) Reysa, R., Granaham, J., Steiner, G., Ransom, E., and Williams, D., "International Space Station (ISS) Major Constituent Analyzer (MCA) On-Orbit Performance", 34th International Conference on Environmental Systems, Technical Paper 2004-01-2546.
- 31.7.9) Gentry, G., Reysa, R., and Williams, D., "International Space Station (ISS) Environmental Control and Life Support (ECLS) System Overview of Events: February 2002-2004, 34th International Conference on Environmental Systems, Technical Paper 2004-01-2383.
- 31.7.10) Limero, T., Beck, S., and James, J., "Development and Performance of the Oxygen Sensor in the CSA-CP Aboard the International Space Station", 34th International Conference on Environmental Systems, Technical Paper 2004-01-2337, Colorado Springs, CO., 2004
- 31.7.11) Williams, D., Gentry, G., "International Space Station Environmental Control and Life Support System Status: 2003-2004", 34th International Conference on Environmental Systems, Technical Paper 2004-01-2382, , Colorado Springs, CO., 2004
- 31.7.12) *op.cit.*, Reysa
- 31.7.13) "The Proceedings of the Skylab Life Sciences Symposium, Volume 1", Lyndon B. Johnson Space Center, August 1974, JSC-09275 or NASA Technical Memorandum TM X-58154, November 1974.

- 31.7.14) Garcia, H., Limero, T., James, J., “Setting Spacecraft Maximum Allowable Concentrations for 1 hour or 24 hour Contingency Exposures to Airborne Chemicals,” 22nd International Conference on Environmental Systems, Technical Paper 921410, Seattle, WA., 1992.
- 31.7.15) *op. cit.*, Palmer
- 31.7.16) Limero, T., Trowbridge, J., Taraszewski, S., Foster, J., and James, J., “Results of the Risk Mitigation Experiment for the Volatile Organic Analyzer”, 28th International Conference on Environmental Systems, Technical Paper 981745, Danvers, MA., 1998.
- 31.7.17) Brittain, A., Bass, P., Breach, J., and Limero, T., “Instrumentation for Analyzing Volatile Organic Compounds in Inhabited Enclosed Environments”, 30th International Conference on Environmental Systems, Technical Paper 2000-01-2434, Toulouse, FR., 2000.
- 31.7.18) Eiceman, G., Karpas, Z., Ion Mobility Spectrometry, 2nd edition, CRC Press, Taylor & Francis Group, Boca Raton, Fl. 2005.
- 31.7.19) Personal communications: VOA Statement of Work 1992
- 31.7.20) Limero, T., Cross, J., Brittain, A., Breach, J., “Selection and Development of GC/IMS Technology to Measure Targeted Volatile Organic Compounds in Spacecraft Habitable Volumes, Proceedings from the 5th International Workshop on Ion Mobility Spectrometry, Jackson, Wyoming, 1996, ISBN 0-9660915-0-7.
- 31.7.21) Limero, T., Reese, E., Trowbridge, Hohman, R., and James, J., “The Volatile Organic Analyzer (VOA) Aboard the International Space Station”, Technical Paper 2002-01-2407, 32nd International Conference on Environmental Systems, San Antonio, TX., 2002.
- 31.7.22) *op cit.*, Limero, 1998
- 31.7.23) Limero, T., Bolland, H., Brokenshire, J., and Breach, J., “Preliminary Results From a Sea Trial of the Volatile Organic Analyzer”, 3rd Submarine Air Monitoring and Purification Conference, Emden, Germany, 2003.
- 31.7.24) Bolland, H., Brokenshire, J., May, I., Breach, J., and Limero, T., “Measurement of Trace Organic Compounds in Submarine Atmospheres”, 4th Submarine Air Monitoring and Purification Conference, Uncasville, CT., 2005.
- 31.7.25) Limero, T., Reese, E., “First Operational Use of the ISS-VOA in a Potential Contingency Event,” International Journal for the Ion Mobility Spectrometry, 5(2002)3, pp 27-30.

- 31.7.26) Limero, T., “Validation of the Volatile Organic Analyzer (VOA) Aboard the International Space Station, Technical Paper 2003-01-2646, 33rd International Conference on Environmental Systems, Vancouver, B.C., 2003.
- 31.7.27) Limero, T., “Volatile Organic Analyzer (VOA) in 2006: Repair, Revalidation, and Restart of Elektron Event”, International Society for Ion Mobility Spectrometry (ISIMS) Conference Proceedings, 2007.
- 31.7.28) Limero, T., Cheng, P., and Boyd, J., “Preliminary Investigation of Gas Chromatography-Differential Mobility Spectrometry as a Replacement for the Volatile Organic Analyzer,” Proceedings of the 15th International Workshop for Ion Mobility Spectrometry, Honolulu, HI., 2006.
- 31.7.29) Limero, T., “Evaluation of Gas Chromatography-Differential Mobility Spectrometry for the Measurement of Air Contaminants in Spacecraft,” 36th International Conference on Environmental Systems, Technical Paper 2006-01-2153, Norfolk, VA., 2006.
- 31.7.30) Limero, T., Reese, E., Cheng, P., “Demonstration of the microAnalyzer’s Measurement of Common Trace Volatile Organic Compounds in Spacecraft Atmospheres,” Technical Paper 2008-01-2128, 38th International Conference on Environmental Systems, San Francisco, CA., 2008.
- 31.7.31) *op cit.*, Eiceman
- 31.7.32) *op cit.*, Limero, Technical Paper 2006-01-2153
- 31.7.33) *op cit.*, Limero, Technical Paper 2008-01-2128
- 31.7.34) Limero, T., Cheng, P., Reese, E., and Trowbridge, J., “Evaluation of the Air Quality Monitor’s Performance in Measuring Volatile Organic Compounds Aboard the International Space Station,” 6th Submarine Air Monitoring Air Purification Conference, San Diego, CA., 2009.
- 31.7.35) *ibid.*, Limero 2009

31.8.1 Mass Determination of Ions Detected by Bennett Ion rf Mass Spectrometer, Johnson, Charles Y., J. Applied Physics V 29, 740-741, 1958.

31.8.2 Small Double Focusing Mass spectrometer, Nier, A. O., Rev. Sci. Inst., 31, 1127-2232, 1960.

31.9.1 Ion Mass Spectrometer on the Explorer XXXI Satellite, Hoffman, J. H., Proceedings of the IEEE, 57, No. 6, 1063-1067. 1969.

31.9.2 Studies of the Composition of the Ionosphere with a Magnetic Deflection Mass spectrometer, Hoffman, J. H., Int. J. Mass Spectrometry and Ion Physics, 4, 315-322, 1970

31.9.3 Initial ion Composition Results from the Isis – 2 Satellite, Hoffman J. H., W. H. Dodson, C. R. Lippincott, H. D. Hammack, J. Geophys. Res. 79, 4246-4261, 1974.

31.10.1 Lunar Orbital Mass Spectrometer Experiment, Hoffman, J. H., R. R. Hodges, and D. E. Evans, Apollo15 Preliminary Science Report, Sect. 19, NASA SP-289, 1972.

31.10.2 Absolute Calibration of Apollo Lunar Orbital Mass spectrometer, Yeager, P., Smith, A., Jackson, J. J., Hoffman, J. H., J Vac. Sci, 1972

31.10.3 Lunar Atmospheric Composition Experiment, Hoffman, J. H., Hodges, R. R., Johnson, F. S. and Evans, D. E., Apollo 17 Preliminary Science Report, Sect. 17, NASA SP-

31.11.1 The magnetic ion mass spectrometer on Atmospheric Explorer, Hoffman, W. B. Hanson, and C. R. Lippincott, Radio Science, 8, No. 4, 315-322, 1973.

31.11.2 The Bennett ion-mass spectrometer on Atmospheric Explorer C and E, Brinton, H. C., L. R. Scott, M. W. Pharo III, and J. T. C. Coulson, Radio Science, 8, No. 4, 323-332, 1973.

31.11.3 The open source neutral mass spectrometer on Atmospheric Explorer C, D, and E, Nier, A. O., W. E. Potter, D. R. Hickman and K. Mauersberger, Radio Science, 8, No. 4, 271-276, 1973.

31.11.4 A neutral-atmosphere composition experiment Atmospheric Explorer C, D, and E, Pelz, Davit T., Carl A. Reber, Alan E. Heden, and George R. Carignan, Radio Science, 8, No. 4, 277-283, 1973.

- 31.12.1 Pioneer Venus Sounder Probe Neutral Mass Spectrometer, IEEE Transactions on Geoscience and Remote Sensing, GE-18, No. 1, 80-84, 1980.
- 31.12.2 The Pioneer Venus Bus Neutral Gas Mass Spectrometer, IEEE Transactions on Geoscience and Remote Sensing, GE-18, No. 1, 122-125, 1980.
- 31.12.3 The Measurement of Chemically Reactive Atmospheric Constituents by Mass spectrometers Carried on High Speed Spacecraft, Nier, A. O., W. E. Potter, D. C. Kayser, and R. G. Finstad, Geophys. Res. Lett., 1, 197, 1074.
- 31.12.4 Bennett Ion Mass Spectrometers on the Pioneer Venus Bus and Orbiter, Taylor, H. A, Jr. H. C. Brinton, T. C. G. Wagner, B. H. Blackwell, and G. R. Cordier, IEEE Transactions on Geoscience and Remote Sensing, GE-18, No. 1, 44-48, 1980.
- 31.12.5 Pioneer Venus Orbiter Neutral Gas Mass Spectrometer Experiment, Niemann, H. B., J. R. Booth, J. E. Cooley, R. E. Hartle, W. T. Kasprzak, N. W. Spenser, S. H. Way, D. M. Hunten, and G. R. Carignan, IEEE Transactions on Geoscience and Remote Sensing, GE-18, No. 1, 60-64, 1980.
- 31.13.1 Phoenix Mars Mission – The Thermal Evolved Gas Analyzer, Hoffman, John H., Roy. C. Chaney, and Hilton Hammack, J. of the Am. Soc. for Mass Spectrometry, 19, No. 10, 1377-1381, 2008.

31.15 Acronyms

Ar	argon
CO2	carbon dioxide
He	helium
HGDL	Hazard and Gas Detection Lab
min	minute
MS	mass spectrometer
N2	nitrogen
ppm	part per million
psig	pound per square inch gauge
sccm	standard cubic centimeter per minute
sccs	standard cubic centimeter per second
scf	standard cubic feet
sec	second
sLpm	standard liter per minute