

Paper Title: Integrated Systems Health Management for Intelligent Systems

Authors: Fernando Figueroa, NASA Stennis Space Center  
Kevin Melcher, NASA Glenn Research Center

AIAA Infotech@Aerospace 2011, 29 - 31 Mar 2011, Hyatt Regency St. Louis at the Arch, St. Louis, Missouri.

## Abstract

The implementation of an integrated system health management (ISHM) capability is fundamentally linked to the management of data, information, and knowledge (DIAK) with the purposeful objective of determining the health of a system. It is akin to having a team of experts who are all individually and collectively observing and analyzing a complex system, and communicating effectively with each other in order to arrive at an accurate and reliable assessment of its health. In this paper, concepts, procedures, and approaches are presented as a foundation for implementing an intelligent systems-relevant ISHM capability. The capability stresses integration of DIAK from all elements of a system. Both ground-based (remote) and on-board ISHM capabilities are compared and contrasted. The information presented is the result of many years of research, development, and maturation of technologies, and of prototype implementations in operational systems.

## Purpose/Motivation

In this paper, Integrated Systems Health Management (ISHM) is presented as an enabling technology for intelligent systems. To that end, a variety of intelligent systems-relevant ISHM topics are addressed and examples presented. The information presented should provide the reader with an understanding of current research and challenges that are relevant to ISHM as one element of an intelligent system.

ISHM has been defined from many perspectives. Here it is defined as a capability that is achieved by integrating data, information, and knowledge (DIAK) that might be distributed throughout the system elements (which inherently implies the capability to manage DIAK associated with distributed sub-systems). DIAK must be available to any element of a system at the right time and in accordance with a meaningful context. ISHM Functional Capability Level (FCL) is measured by how well a system performs the following functions: (1) detect anomalies, (2) diagnose causes, (3) predict future anomalies/failures, and (4) provide the user with an integrated awareness about the condition of important elements of the system as a means of guiding user decisions.

## Scope/Organization

The paper opens with a glossary of relevant ISHM terms. Because the development of an ISHM system is interdisciplinary by nature, terminology is seldom consistently used. It is, therefore important to define the basic terminology that will be used to support ensuing discussions. The paper then describes a process for developing an ISHM capability – standards, qualitative failure models, and optimization of sensor selection and placement are addressed as a part of the development process. Next, an ISHM knowledge domain model is defined that is particularly suited to intelligent systems. This model is based on Data, Information, and Knowledge (DIAK) of the system. This knowledge model is used as the basis for Intelligent ISHM architectures for ground-based (remote) and onboard flight (manned and unmanned) systems. Elements (e.g., diagnostics, prognostics) of the architectures are subsequently described in some detail with examples of specific algorithmic approaches and results. The topic then turns to the system engineering process where the role of ISHM and benefits to the system engineering process are addressed. The chapter closes with brief discussion on impact of ISHM on an intelligent control system and opportunities for advances in verification and validation of complex ISHM systems.

# Integrated Systems Health Management for Intelligent Systems

Fernando Figueroa <sup>1</sup>  
NASA Stennis Space Center, MS, 3952, USA

and

Kevin Melcher <sup>2</sup>  
NASA Glenn Research Center, Cleveland, OH, 44135, USA

## Nomenclature

CSG	=	Chemical Steam Generator
DIaK	=	Data, Information, and Knowledge
DIaKA	=	Data, Information, and Knowledge Architecture
FCL	=	Functional Capability Level
FET	=	Field Effect Transistor
FMEA	=	Failure Modes and Effects Analysis
GN	=	Gaseous Nitrogen
IMBT	=	ISHM Model Building Toolkit
IPA	=	Isopropyl Alcohol
IS	=	Intelligent Sensor
ISHM	=	Integrated Systems Health Management
ISHM-DM	=	ISHM Domain Model
KSC	=	Kennedy Space Center
LC-20	=	Launch Complex 20
LOX	=	Liquid Oxygen
NASA	=	National Aeronautics and Space Administration
NCAP	=	Network Capable Application Processor
OSA-CBM	=	Open Systems Architecture for Condition-Based Maintenance
RCA	=	Root Cause Analysis
RETS	=	Rocket Engine Test Stand
S4	=	Systematic Sensor Selection Strategy
SS	=	Smart Sensor
S&As	=	Sensors and Actuators
SS&As	=	Smart Sensors and Actuators
SSC	=	Stennis Space Center
STE	=	Special Test Equipment
TCP/IP	=	Transmission Control Protocol/Internet Protocol
TEDS	=	Transducer Electronic Data Sheet
TIM	=	Transducer Interface Module
WISE	=	Virtual Intelligent Sensor Environment

## I. Abstract

The implementation of an integrated system health management (ISHM) capability is fundamentally linked to the management of data, information, and knowledge (DIaK) with the purposeful objective of determining the health of a system. Management implies storage, distribution, sharing, maintenance, processing, reasoning, and

---

<sup>1</sup> Innovative Partnerships Office, AIAA Associate Fellow.

<sup>2</sup> Senior Research Engineer, RHC/Controls & Dynamics Branch, 21000 Brookpark Road, Mail Stop 77-1, AIAA Senior Member.

presentation. ISHM is akin to having a team of experts who are all individually and collectively observing and analyzing a complex system, and communicating effectively with each other in order to arrive at an accurate and reliable assessment of its health. In this paper, concepts, procedures, and approaches are presented as a foundation for implementing an intelligent systems-relevant ISHM capability. The capability stresses integration of DIaK from all elements of a system, emphasizing an advance toward an on-board, autonomous capability. Both ground-based (remote) and on-board ISHM capabilities are compared and contrasted. The information presented is the result of many years of research, development, and maturation of technologies, and of prototype implementations in operational systems.

## **II. Introduction**

In this paper, Integrated Systems Health Management (ISHM) is presented as an enabling discipline/technology area for intelligent systems, as well as a capability that embodies “intelligence” in itself. To that end, a variety of intelligent systems-relevant ISHM topics are addressed and examples presented. The information presented should provide the reader with an understanding of current research and challenges that are relevant to ISHM as a core capability of an intelligent system.

ISHM has been defined from many perspectives. Here it is defined as a capability that is achieved by integrating data, information, and knowledge (DIaK) that is conceptually and/or physically distributed throughout the system elements (which inherently implies the capability to manage DIaK associated with distributed sub-systems). The term DIaK management encompasses contextual and timely storage, distribution, sharing, maintenance, processing, reasoning, and presentation. This paradigm implies that DIaK must be available to any element of a system at the right time and in accordance with a meaningful context. ISHM Functional Capability Level (FCL) is measured by how well a system performs the following functions: (1) detect anomalies, (2) diagnose causes, (3) predict future anomalies/failures, (4) enable efficient integration and execution of all phases of the life-cycle of a system from a systems engineering perspective, and (5) provide the user with an integrated awareness about the condition of important elements of the system as a means of guiding user decisions.

The paper is organized as follows: Section III describes core areas of ISHM capability development, including standards and related architectures, the ISHM knowledge model, software tools, intelligent sensors and components, and sensor selection and placement. Section IV describes ISHM in the context of systems design, integration, and engineering. Section V describes briefly controls for ISHM-Enabled systems. Section VI describes briefly opportunities for advances in validation and verification of ISHM systems. Section VII provides conclusions.

## **III. ISHM Capability Development**

ISHM capability is currently done, but for complex systems, it involves many people, it is very costly and difficult to improve with time and use, it involves minimal integration of DIaK across the system, it is not comprehensive (does not include all elements of a system or much DIaK about the system), and it is not continuous (a people-based system is generally not vigilant 24 hours a day, every day). The following sections describe what is needed to achieve ISHM capability that is mainly on-board the system, affordable and evolutionary throughout the life of the system, integrates DIaK across the system, is continuous, and is comprehensive. In order to make this possible, it is necessary that the ISHM capability must incorporate a knowledge-based approach, and hence embody “intelligence.”

### **A. Standards for ISHM Implementation**

The development of an ISHM capability requires the use of models (knowledge) applied to information and data associated with various elements that make up a system. Here, the term “model” is used in the broadest sense as it may include qualitative (e.g. heuristics), analytic, statistical, fuzzy-logic, classic logic, artificial neural network and other types of models. Use of models is enabled by management of DIaK, encompassing storage, distribution, sharing, maintenance, processing, reasoning, and presentation. In order to make this possible in a generic manner, meaning not for a specific application; standards must be established so that DIaK can be managed in a plug&play and interoperable manner.

Standards for ISHM must be at a high enough layer in the infrastructure so that they are largely independent of the physical (e.g. Ethernet) and transmission (e.g. TCP/IP) layers. Example standards for ISHM include the IEEE 1451 family of standards for smart sensors and actuators, the Open Systems Architecture for Condition-Based Maintenance (OSA-CBM) standard, and the Machine Information Management Open Standards Alliance (MIMOSA). These standards are sufficiently abstracted so that they can be implemented as part of any physical or transmission architecture.

## 1. IEEE 1451 Family of Standards for Smart Sensors and Actuators (SS&A)

The IEEE 1451 family of standards was developed by government and private entities under the leadership of the National Institute of Standards and Technology (NIST). Reference XX (book chapter) provides a summary of the standards and their use. In creating these standards, the objective was to standardize DIaK associated with sensors and actuators (S&As). The standards are described as a family because, as evidenced from the quote in the following paragraph, they address various elements and functions of Smart Sensors and Actuators (SS&As). The notion is that SS&As must incorporate DIaK related to their functionality and provide their DIaK, via a communications network, to other systems or functions that use and manage S&As.

*“The IEEE (Institute of Electrical and Electronics Engineers) 1451 smart transducer interface standards provide the common interface and enabling technology for the connectivity of transducers to microprocessors, control and field networks, and data acquisition and instrumentation systems. The standardized TEDS specified by IEEE 1451.2 allows the self-description of sensors and the interfaces provide a standardized mechanism to facilitate the plug and play of sensors to networks. The network-independent smart transducer object model defined by IEEE 1451.1 allows sensor manufacturers to support multiple networks and protocols. Thus, transducer-to-network interoperability is on the horizon. The inclusion of P1451.3 and P1451.4 to the family of 1451 standards will meet the needs of the analog transducer users for high-speed applications. In the long run, transducer vendors and users, system integrators and network providers can all benefit from the IEEE 1451 interface standards [1].”*

The most common physical architectures for systems are bus-based multi-drop configurations. Figure 1 shows configurations and implementation of IEEE 1451 standard, and a short summary is provided below. The standards are still being modified, but the intent here is to provide a sense of how the standards can be used to enable interoperability and plug&play capability with networked transducers with embedded information (hence, smart transducers).

*IEEE P1451.0* defines a set of common commands, common operations, and Transducer Electronic Data Sheet (TEDS) for the family of IEEE 1451 standards. The commands allow communication with sensors or actuators in IEEE 1451-based wired and wireless networks. The functionality is independent of the physical communications media and the network node called Network Capable Application Processor (NCAP).

*IEEE 1451.1* defines a common object model describing the behavior of smart transducers (sensor and actuators). It defines the communication models used for the standard, which include the client-server and publish-subscribe models. Application software based on IEEE 1451; running in the NCAP, communicate with transducers through any physical layer standards as needed for a particular application. The standard enables communications among NCAPs and to higher level systems, in a network neutral manner.

*IEEE 1451.2* defines transducers-to-NCAP interface and TEDS for a point-to-point configuration. Transducers are part of a Transducer Interface Module (TIM). The original standard describes a communication layer based on enhanced SPI (Serial Peripheral Interface) with additional HW lines for flow control and timing.

*IEEE 1451.3* defines a transducer-to-NCAP interface and TEDS for multi-drop transducers using a distributed communications architecture. It allows many transducers to be arrayed as nodes, on a multi-drop transducer network, sharing a common pair of wires.

*IEEE 1451.4* defines a mixed-mode interface for analog transducers with analog and digital operating modes. A TEDS was added to a traditional two-wire, constant current excited sensor containing a FET amplifier. The TEDS model was also refined to include critical information that must fit in a small memory device, needed by very small transducers. Templates are used to describe the data structure of TEDS. The current templates cover accelerometers, strain gages, current loop sensors, microphones, thermocouples, and others.

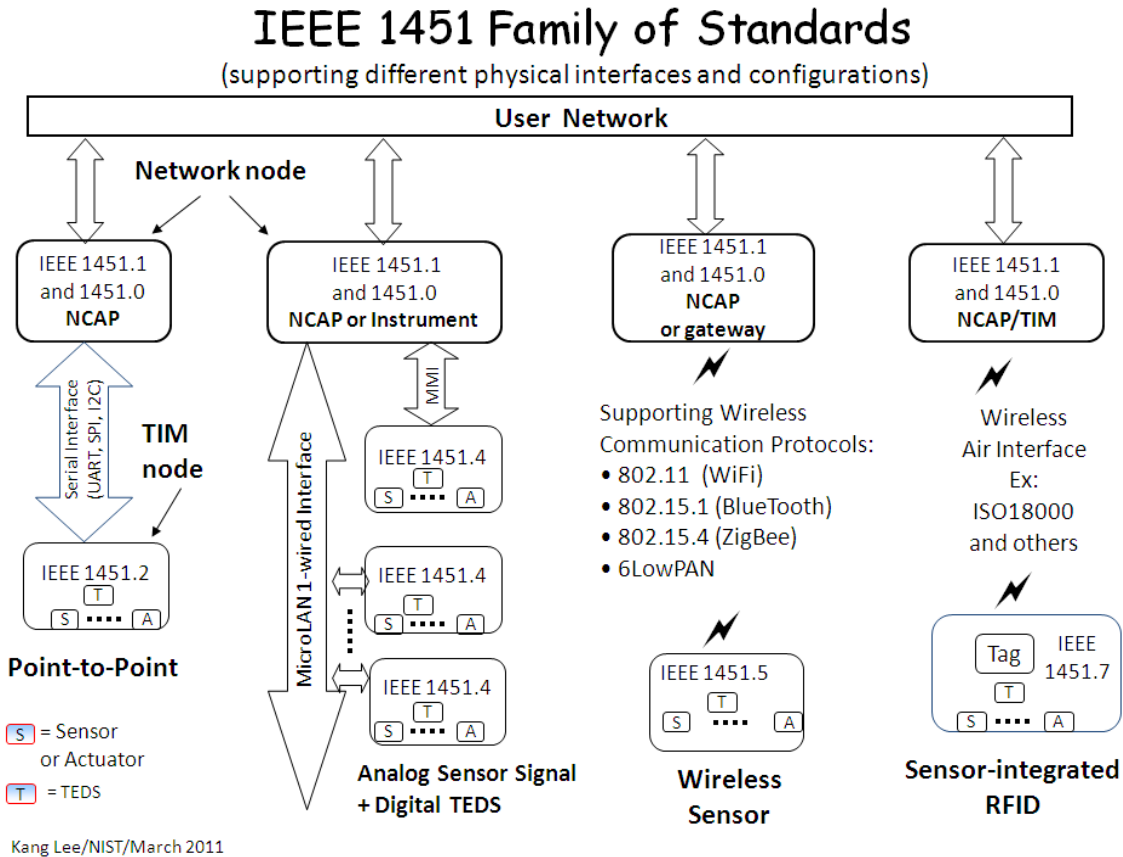

**Figure 1. IEEE 1451 Family of Standards (Courtesy of Dr. Kang Lee from NIST).**

*IEEE P1451.5* defines a transducer-to-NCAP interface and TEDS for wireless transducers. Wireless communication protocol standards such as 802.11 (WiFi), 802.15.1 (Bluetooth), 802.15.4 (ZigBee) are being considered as some of the physical interfaces for IEEE P1451.5. The objective is to be able to communicate with a wireless transducer embodying any of these three wireless protocols.

*IEEE P1451.6* defines a transducer-to-NCAP interface and TEDS using the high-speed CANopen network interface. Both intrinsically safe and non-intrinsically safe applications are supported. It defines a mapping of the 1451 TEDS to the CANopen dictionary entries as well as communication messages, process data, configuration parameter, and diagnosis information. It adopts the CANopen device profile for measuring devices and closed-loop controllers.

## 2. OSA-CBM Standard

The OSA-CBM standard was developed by government and private entities. This standard addresses management of health information from any element, subsystem, system, or system-of-systems. The foundation is the definition of layers where health information is organized according to the degree of processing, and hence amount of DIaK employed, to determine health condition [2, 3]. The standard focuses on automated real-time management of health information. In contrast, health management over extended periods of time (non-real time) is typically based on large databases, and done primarily by people. This approach is standardized under the Machine Information Management Open Standards Alliance (MIMOSA) organization [2].

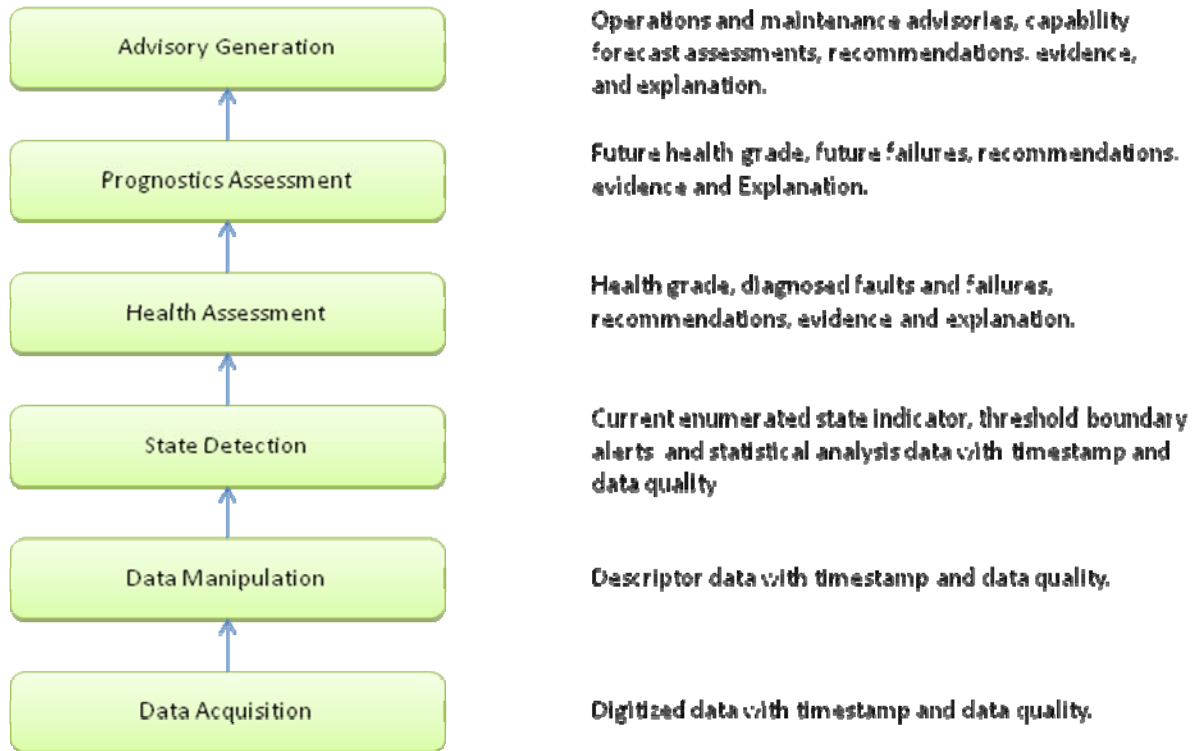

**Figure 2. CBM layered health DIaK architecture.**

**3. Machine Information Management Open Standards Alliance (MIMOSA)**

MIMOSA “is a non-profit trade association dedicated to developing and encouraging the adoption of open information standards for Operations and Maintenance in manufacturing, fleet, and facility environments. MIMOSA’s open standards enable collaborative asset lifecycle management in both commercial and military applications.” [2].

**4. Example Implementation of IEEE 1451 and OSA-CBM Standards**

Figure 3 shows a physical architecture (bus-based, multi drop, Ethernet network) for a pilot ISHM system implemented at NASA Kennedy Space Center, Launch Complex 20 (LC-20) [3]. The architecture is hierarchical, with buses at various levels, where higher-level information flows up toward the site-wide management computer. This is a typical architecture for systems in most industries, including aerospace. Standards were implemented in the lower part of the physical architecture (bus showing IEEE 1451.1 and OSA-CBM standards on Ethernet), but it was sufficient to demonstrate the impact of standards for ISHM implementation in an operational system, during a test at the LC-20.

The experiment demonstrated interoperability of ISHM systems developed by three different providers: NASA Stennis Space Center (NASA SSC), NASA Kennedy Space Center (NASA KSC), and the Pennsylvania State University’s Applied Research Laboratory (PSU-ARL). The interoperability was enabled through the use of the IEEE 1451 and OSA-CBM standards.

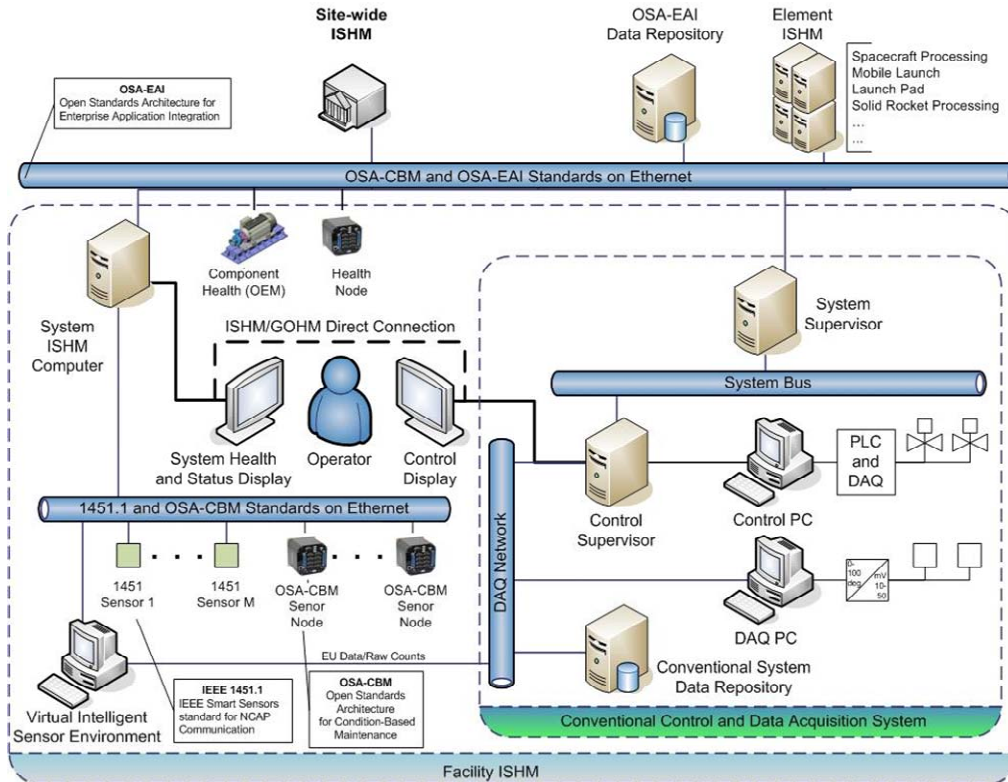

**Figure 3. Architecture for pilot ISHM system implemented at NASA Kennedy Space Center, Launch Complex 20 (LC-20) showing the use of IEEE 1451.1, OSA-CBM, and OSA-EAI standards.**

**B. ISHM Knowledge Model (ISHM-DM)**

The concept of an ISHM Domain Model (ISHM-DM) has been introduced previously [4, 5]. ISHM-DM embodies DIaK that is needed to achieve ISHM capability; including system element identification and specifications, and inter-element relationships used in reasoning approaches. Data is available from sensors and components. Distribution of DIaK associated among the physical elements of a system gives rise to an ISHM architecture that enables distributed management of DIaK to achieve ISHM functionality. The ISHM architecture is a DIaK Architecture (DIaKA), where intelligent processes (e.g. physics-based models) providing various degrees of integration (through inter-dependencies) are used to achieve the desired ISHM capability; and where DIaK are managed in a distributed manner (Figure 4). This hierarchical architecture enables abstracting models of processes occurring throughout the system (e.g. tank pressurization, subsystem leak, valve leak, sensor flat, etc.), and is conceptually different from a typical architecture depicting the physical composition of a system, where the hierarchy is based on simpler physical elements being assembled into more complex sub-systems and systems.

Figure 5 is another depiction of the DIaKA. DIaK are distributed among the elements of a system, including sensors, actuators, and components; as well as subsystems, and systems. The icons are active repositories of data and information pertinent to their function, operation, and health. They also contain process models (knowledge) that enable ISHM functionality. Figure 5 shows a representation of the DIaKA as it is related to an ISHM-DM of a simple rocket test stand system.

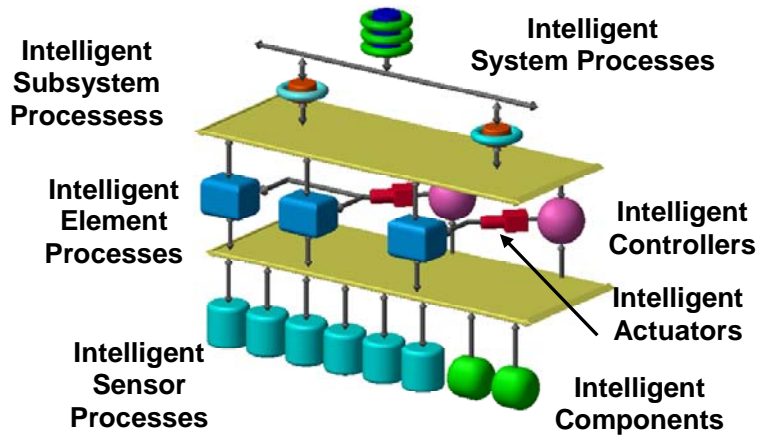

Figure 4. Data, Information, and Knowledge Architecture for Intelligent ISHM.

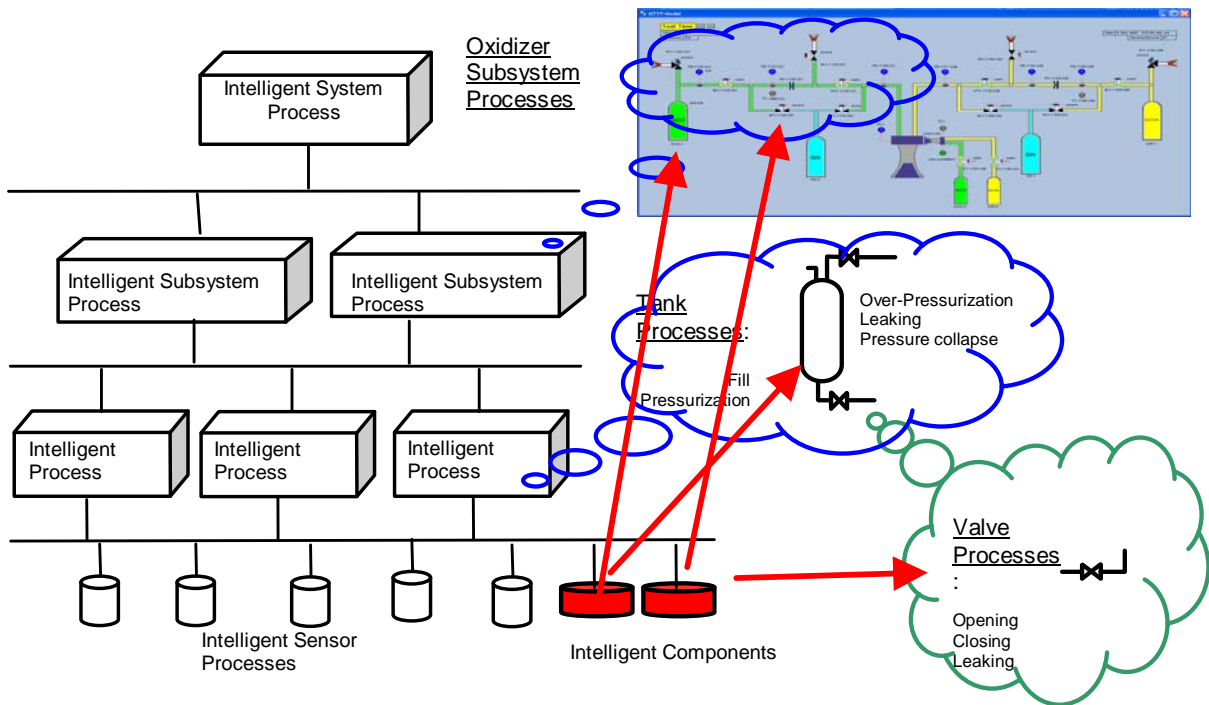

Figure 5. DIaKA showing correspondence with ISHM-DM elements of a small rocket engine test stand. Process models are executed often in parallel for consistency checking that leads to anomaly detection and reasoning about health of processes, sensors, and components.

The DIaKA supports the following paradigm. Sensor icons are repositories for sensor processes that operate on measurements within a local context, independent of other elements of the system. Sensor processes are, for example, algorithms to determine level of noise, changes on level of noise, flat signals, time response characteristics, etc. In addition, sensor processes include health assessment processes focused on determining: sensor health, and the quality of the measurement. Health assessment sensor processes also receive information from other processes higher in the hierarchy to improve their health assessment. For example, a process model of flow from a tank through a valve, to atmosphere; can allow consistency checks among pressure and temperature sensors on the tank along the path of the flow. If one sensor is inconsistent with the model, this information is fed back to the sensor to



improve its own health assessment and anomaly determination. The same applies to component processes. The final objective is to determine the health of sensors and components; and do it with maximum utilization of DIaK embodied in the various layers of processes in the hierarchy. This approach is described in reference [4].

### C. Software Capabilities to Develop ISHM Domain Models

Core capabilities of ISHM include: (1) detect anomalies, (2) diagnose causes, (3) predict future anomalies/failures, (4) enable efficient integration and execution of all phases of the life-cycle of a system from a systems engineering perspective, and (5) provide the user with an integrated awareness about the condition of important elements of the system as a means of guiding user decisions. These capabilities are to provide continuous and comprehensive awareness about the health of every element of a system. DIaK must be employed to do the reasoning leading to achieving the core capabilities. Furthermore, multiple simultaneous process models and approaches should be employed to achieve maximum functional capability level (FCL), that is to make effective use of all DIaK embodied in the ISHM-DM. A software system for ISHM capability should support all core capabilities by integrating systematically DIaK through the ISHM-DM. The following requirements must be met by the software system:

*Object orientation*: object representation of system physical elements and associated process models is the best way to embed DIaK in a systematic and in an organized manner. Object orientation also embodies re-use of software that is modularized into objects, and allows a more intuitive understanding of the code and its outcomes.

*Distribution of ISHM-DM's within and across networks*: ISHM-DM's might be distributed among processors connected to a network, simply because it is necessary to use parallel processing, and/or ISHM-DM's might be created by different people in various geographic locations. As complexity of systems increase, and/or a large number of process models are used in achieving effective ISHM capability, it is not reasonable or manageable to do this with a centralized architecture.

*Distribution across processing units*: Since multiple process models are expected to be running at any given time, the software environments should support parallel processing.

*Inference engine*: Many tasks require an inference engine. Reasoning and decision making leading to anomaly detection, diagnostics, effects, and prognostics; require contextual integrity and cause-effect analysis using heterogeneous data and information. The inference engine must also allow accurate representation and automatic execution of failure modes and effects analysis (FMEA).

*Integrated management of distributed DIaK*: DIaK must be managed in a way to allow embodiment of systems thinking across elements and subsystems. Often this is enabled by definitions of relationships among elements of systems that can be physically visible (i.e. attached to, belong to a system); or more abstracted relationships, as it relates to involvement in process models (e.g. pressure sensors associated to a particular subsystem, subsystem definitions that change with configuration, etc.).

*Definition of dynamic relationships among objects for use in reasoning*: Often, the framework for reasoning and application of process models changes dynamically with configuration changes, stages of operation, etc. This also means that relationships among objects and processes change dynamically, and must be represented in the ISHM-DM's. For example, reasoning to detect leaks in a sealed subsystem requires that membership of elements to sealed subsystems must change with valve state changes.

*Iconic representation of systems objects with visible and virtual links (relationships) used to provide intuitive representation of reasoning and context*: The mix of object orientation and iconic representation of DIaK provides the ability to intuitively visualize interrelationships and dig deep into details of the ISHM system. As complexity increases, graphical programming and visualization become essential.

A software environment developed by NASA Stennis Space Center and General Atomics [4, 6, 7, and 8] meets most of the requirements above. The software was developed using G2 [9], which is a commercial programming environment for implementation of intelligent applications.

### D. Intelligent Sensors and Components

The lower elements in the DIaKA (Figure 5) represent processes associated with sensors and components; where "components" is intended to encompass any element that is not a sensor; e.g. tanks, pumps, etc. These elements directly represent physical entities in the system; and, in the future, is they are expected to incorporate their own embedded processing and networking capabilities. This is already true for sensors, as many "intelligent sensor" concepts are now available commercially, and more are in development [10, 11].

There are many definitions for "Intelligent Sensor" or IS. The following definition is based on the foundation provided by the IEEE 1451 family of standards for Smart Sensors and Actuators. It is reasonable to assume that the standard defines a "Smart Sensor (SS)," as described previously in Section A "Standards for ISHM

Implementation.” “Intelligent Sensor” is therefore a “Smart Sensor” with the ability to provide the following functionality: (1) measurement, (2) measure of the quality of the measurement, and (3) measure of the “health” of the sensor. The better the sensor provides functionalities 2 and 3, the more intelligent it is.

Implementation of IS’s can be done in many ways. Commercial SS incorporating TEDS in-a-chip have been available for some time (a web search will reveal many offerings). Some IS or SS modules have been developed in industry. These are small format units that incorporate signal conditioning, data acquisition, processing capability, and protocols for communicating as network elements [10, 11]. In other cases, IS capability is enabled by a combination of hardware and software that turns classic sensors into smart sensors; as is the case with products from National Instruments [12]. Intelligent sensor functionality has also been implemented purely in software, again, to turn classic sensors into intelligent ones. Figure 6 [6] shows the configuration of a pilot ISHM implementation for a rocket engine test stand. Here the Virtual Intelligent Sensor Environment (VISE) turns all non-intelligent test stand sensors into intelligent sensors. The VISE publishes IS data and information to a bus for consumption by the ISHM system and other users such as repositories and visualization systems. Some of the processes embedded in IS’s include:

- Noise Level Assessment and History Spike Detection and History
- Flat Signal Detection and History
- Response Time Characterization
- Intermittency Characterization and History
- Physical Detachment Characterization and History
- Regime Characterization and History
- Curve Fit on Identified Regimes

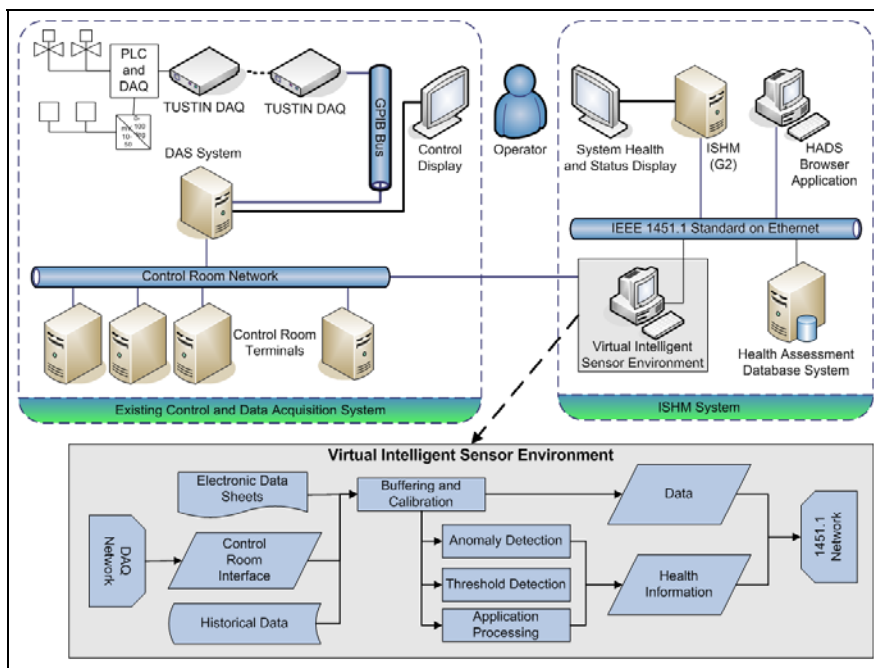
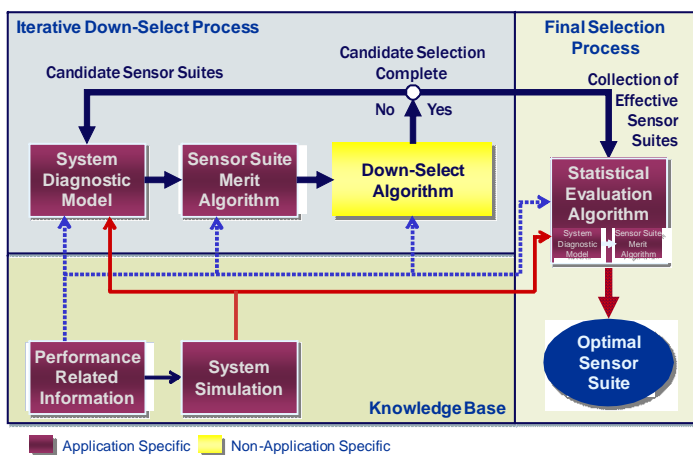

**Figure 3. Architecture showing implementation of intelligent sensors through the Virtual Intelligent Sensor Environment.**

### E. Optimizing sensor selection and placement for ISHM

When developing an ISHM capability from the ground up, one must optimize sensor suites to achieve maximum functional capability (anomaly detection, diagnosis, effects, prognostics). References [13-17] provide context for this section. For example, the Systematic Sensor Selection Strategy (S4) is a model-based procedure for systematically and quantitatively identifying the sensor compliment that optimally achieves the health assessment goals of a system. Properly formulated, an S4 application can be used to determine whether or not existing sensors

meet requirements for system health assessment; and, if not, to justify the addition of sensors that allow those requirements to be met. As shown in Figure 7, S4 can be logically partitioned into three major elements: the *Knowledge Base*, the *Iterative Down-Select Process*, and the *Final Selection Process*. The *Knowledge Base* consists of system design information and heritage experience together with a focus on components with health implications. The *Iterative Down-Select Process* identifies a group or groups of sensors that provide the highest fault detection and isolation performance for targeted fault scenarios. This process is further composed of three basic modules: the system diagnostic model, the sensor suite merit algorithm, and the down-select algorithm. The result of the *Iterative Down-Select Process* is a single sensor suite with the highest merit algorithm score (i.e., optimal) or a group of highest-performing (i.e., nearly-optimal) sensor suites with closely-matched merit algorithm scores. In the final selection process, the group of highest performing sensor suites is evaluated using a statistical algorithm that provides the final robustness test for each sensor suite. The result of the *Final Selection Process* is a sensor suite that optimally achieves the system health assessment goals.

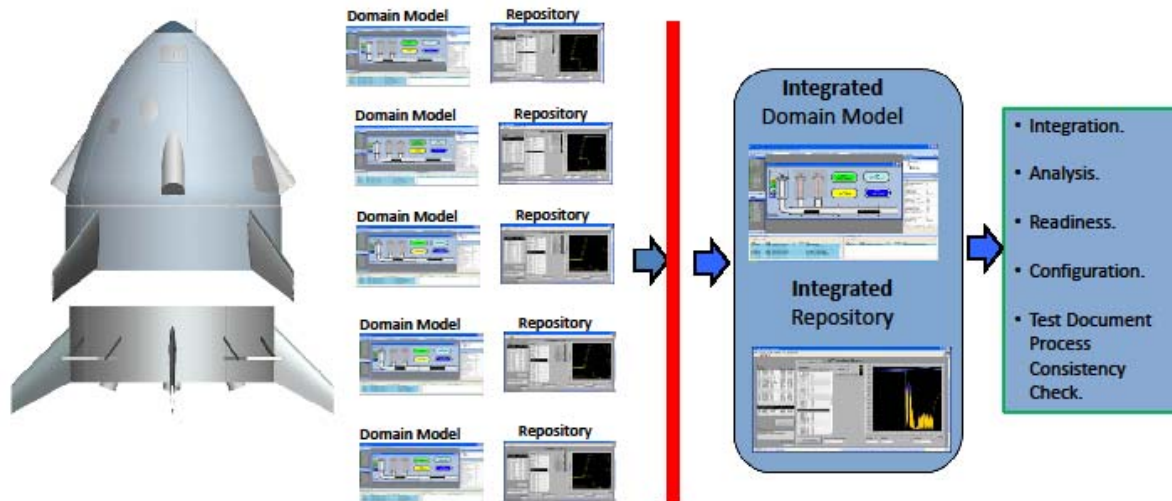

**Figure 7. ISHM Sensor Selection Strategy (S4) for optimizing sensor selection and placement.**

#### IV. ISHM in Systems Design, Integration, and Engineering

Systems Integration and Engineering (SI&E) practices are employed to build complex systems. SI&E for aerospace systems has developed into its own discipline, although theories and concepts have not been adequately formalized in an academic sense. The role of ISHM in SI&E is linked to the concept of ISHM-DM's, whereby every element that is part of a system comes with its own ISHM-DM that can be rolled-up into an overall system ISHM-DM in a plug&play mode. In this sense, as soon as two elements are assembled, the ISHM-DM of each element is incorporated into the ISHM-DM of the assembly. In this manner, DIaK compartmentalized in each element becomes immediately available to the ISHM-DM of the assembly. Figure 8 shows the concept of systems integration to aggregate ISHM-DM's providing comprehensive and continuous vigilance on the health of the elements throughout the integration process.

The incorporation of ISHM-DM's as products of the design implies that parts of a system must be accompanied by DIaK relevant to determining health of the parts. Failure modes and effects must be captured, as well as information such as expected life, specifications, usage, operational environments, etc.



**Figure 8. ISHM concept for systems integration of ISHM-DM's**

### V. Intelligent Control for ISHM-Enabled Systems

Control of complex systems that are ISHM-enabled is a nascent area, simply because ISHM itself is also relatively new. The objective is for the control function to make use of system health information in order to achieve its objectives. Suspect (i.e., disqualified) sensors might be removed from use by critical control functions; anomalous components might need to be contained so maintain system function; and, in severe cases, new mission objectives may need to be identified. The paradigm implies that control systems become users of health information, while at the same time making use of actuators to help further improve determination of the system health. This can lead to yet another area of control, specifically focused on helping the ISHM capability detect anomalies, diagnose causes, and determine effects. An example of a control system that incorporates sensor health information communicated using the IEEE 1451.1 Standard is described in reference [18].

### VI. Opportunities for Advances in Control Verification and Validation Considerations

This paper describes ISHM capability implementation as purposeful management of DIaK with a focus on determining the health of each element in a system. The need to use knowledge, and hence inference engines; and the complexities of parallel processing and reconciliation of potentially inconsistent outcomes that lead to anomaly determination; requires advances in verification and validation of the ISHM capability itself. This paper only raises this issue, but the scope of this topic is broad, and is left for a future discussion.

### VII. Conclusion

This paper describes concepts, architectures, paradigms, tools, and implementations of ISHM capability. The purpose is to show that ISHM capability must be implemented as a Knowledge-based capability, through management of data, information, and knowledge (DIaK); whereby “management” implies storage, distribution, sharing, maintenance, processing, reasoning, and presentation. The emphasis is also to note that ISHM capability increments “intelligence” of the system where it is implemented. We can then talk about ISHM-Enabled systems; with a potential to generate significant advances in Systems Design, Integration, and Engineering; as well as in Systems Control. The reader should also infer that much work is needed in developing ISHM-DM's, tools to create and use the ISHM-DM's, implementation of standards for management of DIaK to achieve Plug&Play and interoperability. Last, but not least, it is important to note that the ISHM DIaK Architecture (DIaKA) described addresses the need for focusing on processes that take place in systems for consistency checking, leading to anomaly detection.

## Acknowledgements

The authors would like to thank NASA for providing the opportunity to work on advancing the area of ISHM. The authors also express their profound appreciation to the many individuals that through discussions and interactions have enriched their understanding of ISHM and made possible this paper.

## Bibliography

1. [http://www.nist.gov/manuscript-publication-search.cfm?pub\\_id=821920](http://www.nist.gov/manuscript-publication-search.cfm?pub_id=821920)
2. <http://www.mimosa.org>.
3. Karl Reichard, Fernando Figueroa, Rebecca Oosdyke, John Schmalzel, and Jose Perotti, "An ISHM Architecture for Ground Operations Health Management," ISHM Conference, Covington Convention Center, KY, August 11-14, 2008.
4. Figueroa, F., Schmalzel, J., Walker, M., Venkatesh, M., Kapadia, R., "Integrated System Health Management: Foundational Concepts, Approach, and Implementation," *AIAA Infotech@Aerospace Conference*, 20-22 April 2010.
5. Figueroa, F., and Schmalzel, J., "Rocket Testing and Integrated System Health Management," *Condition Monitoring and Control for Intelligent Manufacturing*, edited by L. Wang and R. Gao, Springer Series in Advanced Manufacturing, Springer Verlag, UK, 2006, pp. 373-392.
6. Fernando Figueroa, John Schmalzel, Jonathan Morris, Mark Turowski, and Richard Franzl, "Integrated System Health Management: Pilot Operational Implementation in a Rocket Engine Test Stand," AIAA 2010-3454, AIAA Infotech@Aerospace 2010 Conference, 20-22 April 2010, Atlanta, GA.
7. R. Kapadia, R. Gross, M. Walker, M. Venkatesh. "Health Monitoring Assessment and Prognostics (HealthMAP™) for Advanced Arresting Gear System. PHM Society Conference 2009, San Diego, CA, October 2009.
8. M. Walker, "Model-based Reasoning Applications for Remote Intelligent Systems Health Management", ASNE Intelligent Ships Symposium, May 2007.
9. <http://www.gensym.com>.
10. <http://www.eesensors.com/index.html>.
11. <http://www.mobitrum.com>.
12. <http://www.ni.com>.
13. Melcher, K.J., Sowers, T.J., Maul, W.A., "Meeting the Challenges of Exploration Systems: Health Management Technologies for Aerospace Systems with Emphasis on Propulsion," NASA TM 2005-214026, *First International Forum on Integrated System Health Engineering and Management in Aerospace*, 7-10 November 2005.
14. Santi, L.M., Sowers, T.S., Aguilar, R.B., "Optimal Sensor Selection for Health Monitoring Systems", AIAA 2005-4485, *AIAA 41st Joint Propulsion Conference and Exhibit*, 10-13 July 2005.
15. Maul, W.A., Melcher, K.J., Chicatelli, A.K., and Sowers, T.S., "Sensor Data Qualification for Autonomous Operation of Space Systems," NASA TM 2006-214475, 2006 Fall Symposium Series sponsored by the American Association for Artificial Intelligence, 13-15 October 2006.
16. Melcher, K.J., Fulton, C.E., Maul, W.A., Sowers, T.S., "Development and Application of a Portable Health Algorithms Test System," NASA TM-2007-214840, 54th Joint Army-Navy-NASA-Air Force (JANNAF) Propulsion Meeting, 14-17 May 2007.
17. Melcher, K.J., Maul, W.A., Fulton, C.F., Wong, E., "Sensor Data Qualification Proof-of-Concept Demonstration," NASA TM-215518, Joint Army-Navy-NASA-Air Force (JANNAF) 6th Modeling & Simulation Subcommittee, 4th Liquid Propulsion Subcommittee, 3rd Spacecraft Propulsion Subcommittee Joint Meeting, 8-12 December 2008.
18. D. Jethwa, R. R. Selmic and F. Figueroa, "Real-time implementation of intelligent actuator control with a transducer health monitoring capability," *International Journal of Factory Automation, Robotics, and Soft Computing*, no. 1, pp. 5-10, January 2009.

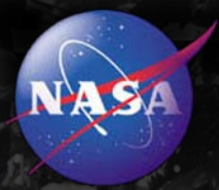

# Integrated Systems Health Management for Intelligent Systems

**Fernando Figueroa, NASA Stennis Space Center, MS**  
**Kevin Melcher, NASA Glenn Research Center, OH**

**AIAA Infotech@Aerospace**  
**March 29-31, 2011**  
**St. Louis, MO, USA**



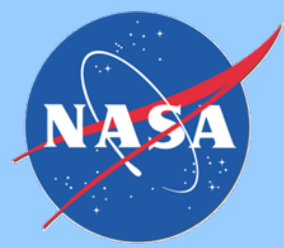

# Acknowledgements

The authors would like to thank NASA for providing the opportunity to work on advancing the area of ISHM.

The authors also express their profound appreciation to the many individuals that, through insightful discussions and interactions, have enriched their understanding of ISHM.

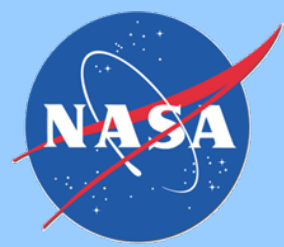

# Outline

- Context of the paper.
- ISHM Definition.
- ISHM Capability Development.
  - ISHM Knowledge Model.
  - Standards for ISHM Implementation.
  - Software to develop ISHM Domain Models (ISHM-DM's).
  - Intelligent Sensors and Components.
- Sensor Optimization and Placement for ISHM.
- ISHM in Systems Design, Engineering, and Integration.
- Intelligent Control for ISHM-Enabled Systems.
- Verification and Validation Considerations.





# Context of the Paper

- **Intelligent System:** Manages data, information, and knowledge (DIAK) to achieve its mission (Manage: storage, distribution, sharing, maintenance, processing, reasoning, and presentation)
- An attribute or quality of intelligent systems should be to possess a health management capability that:
  - Employs knowledge about the system embodying “systems thinking” (captures interactions among elements of the system).
  - Is continuously vigilant.
  - Is comprehensive in assessing health of each element of a system.
  - Is systematically evolutionary to achieve higher and higher functional capability levels (increasing effectiveness).
- In order to make this capability possible, the health management system needs to incorporate “intelligence.”

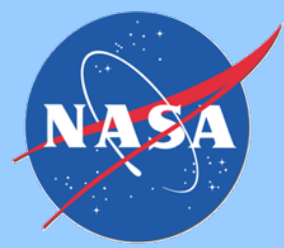

# ISHM Definition

- Its own discipline, or sub-discipline under Aerospace Systems Design, Engineering, and Integration.
- Management of data, information, and knowledge (DIaK) with the purposeful objective of determining the health of a system (Management: storage, distribution, sharing, maintenance, processing, reasoning, and presentation).
- ISHM is akin to having a broad-base team of experts who are all individually and collectively observing and analyzing a complex system, and communicating effectively with each other in order to arrive at an accurate and reliable assessment of its health.



# People-Based ISHM is Being Done Today

MOVE CAPABILITY TOWARD LEVELS 2 AND 1  
DECREASE NEED FOR SUPPORT FROM LOWER LAYERS

## International Space Station

## Rocket Engine Test Stand

Layer 1  
Vehicle/  
Test Stand

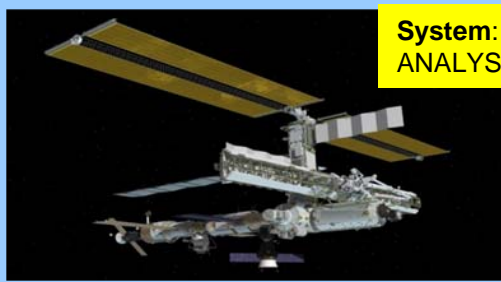

**System: ON BOARD AUTOMATED ANALYSIS CAPABILITY**



Signal threshold violation detection

Layer 2  
Astronaut/  
Test Conductor



**Operator: FASTER, MORE ACCURATE ANALYSIS**



Added DIaK from on-board users.

Layer 3  
Control Room



**Support: FASTER, MORE ACCURATE ANALYSIS**  
**Decreased Need**



Added DIaK from broad group of experts.

Layer 4  
Back Control Room



**Support: FASTER, MORE ACCURATE ANALYSIS**  
**Decreased Need**



Added DIaK resources from larger community

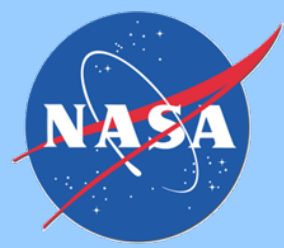

# Determination of Health

- Use available SYSTEM-WIDE data, information, and knowledge (DIAK) to
  - Identify system state.
  - Detect anomaly indicators.
  - Determine and confirm anomalies.
  - Diagnose causes and determine effects.
  - Predict future anomalies.
  - Recommend timely mitigation steps.
  - Evolve to incorporate new knowledge.
  - Enable integrated system awareness by the user (make available relevant information when needed and allow to dig deeper for details).
  - Manage health information (e.g. anomalies, redlines).
  - Capture and manage usage information (e.g. thermal cycles).
  - Capture and manage design life and maintenance schedule.
  - Enable automated configuration.
  - Implement automated and comprehensive data analysis.
  - Provide verification of consistency among system states and procedures.

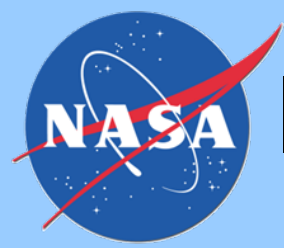

# ISHM Capability Development

## ISHM Knowledge Model

- A plethora of Data, Information, and Knowledge (DlaK) must be applied to achieve high functional capability level (FCL) health management.
- The ISHM Domain Model (ISHM-DM) encompasses DlaK and the tools to implement ISHM capability.

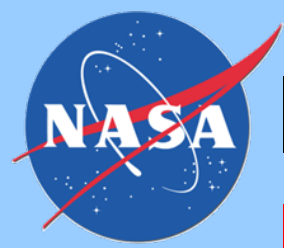

# ISHM Capability Development

## ISHM Knowledge Architecture

- DIaK in the ISHM-DM are associated with software objects that represent **process models** that take place in objects and/or collections of objects that encompass a system of interest.
- Process models are organized as objects in a hierarchical network (ISHM DIaK Architecture), to reflect levels of complexity as processes take place involving single elements, subsystems, or the entire system.
  - Local processes using local DIaK are at the bottom of the hierarchy.
  - Processes using increasing DIaK occupy higher levels in the network.

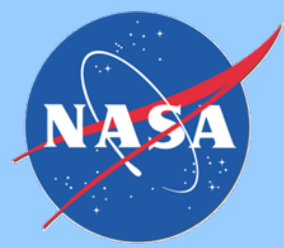

# ISHM DiaK Architecture (DiaKA)

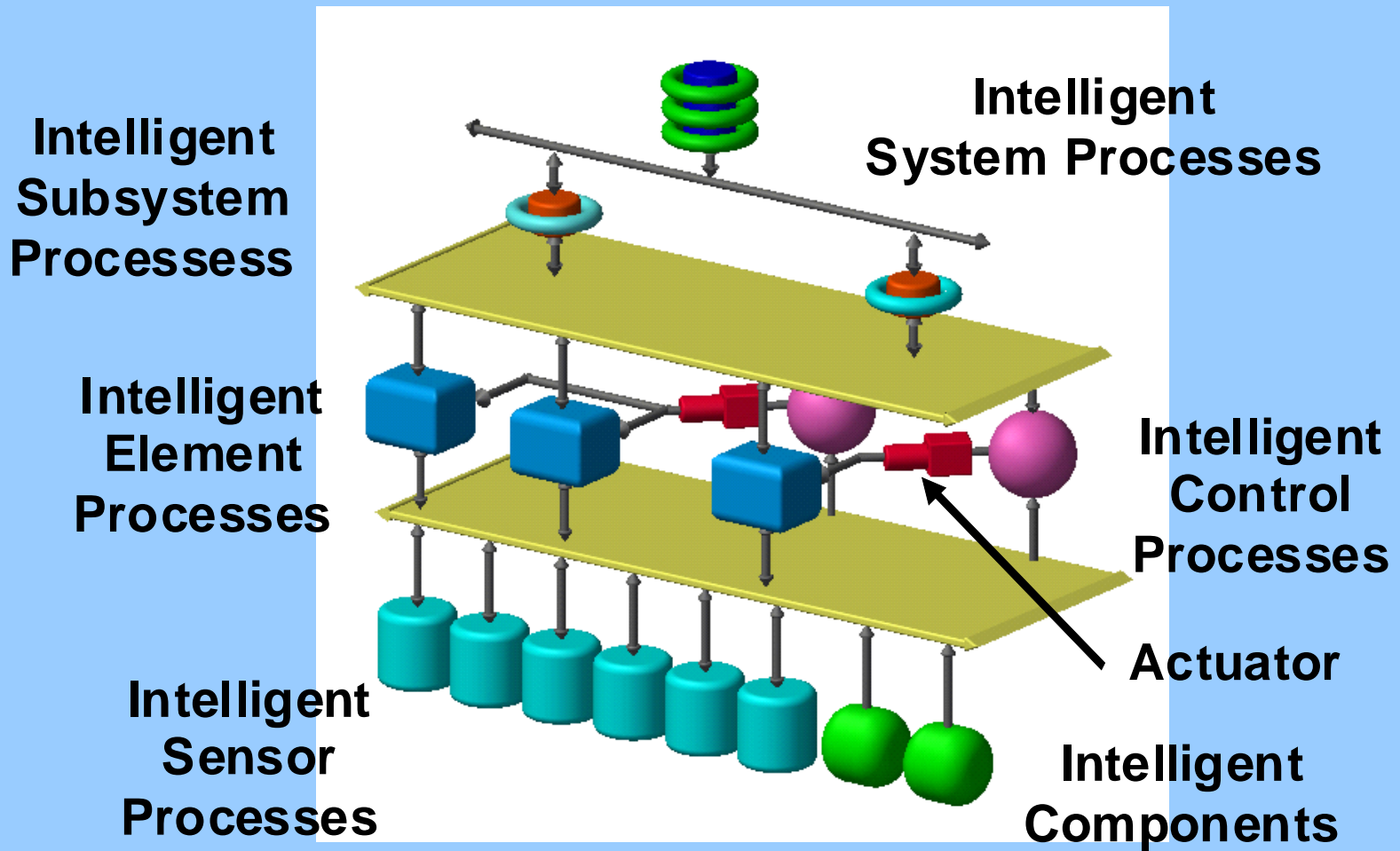

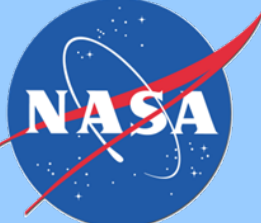

# Detection and Confirmation of Anomalies Consistency Checking Cycle

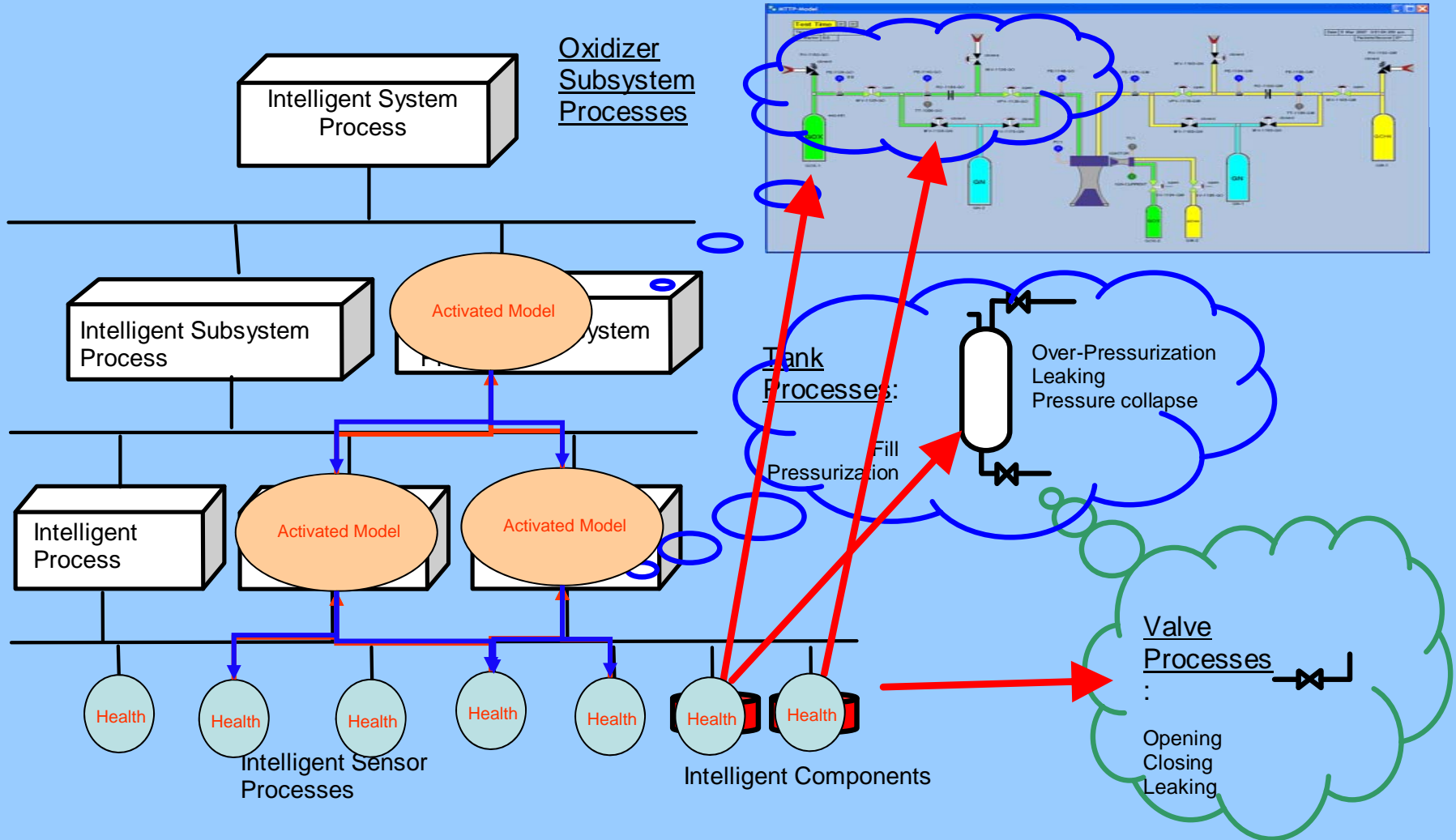



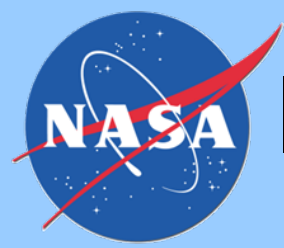

# ISHM Capability Development

## Standards for ISHM

- IEEE 1451 Family of Standards for Smart Sensors and Actuators. Lead by NIST (Dr. Kang Lee).
- OSA-CBM (Open Systems Architecture for Condition Based Maintenance). Developed by industry and government, and transferred to the MIMOSA (Machine Information Management Open Standards Alliance) organization.
- OSA-EIA (Open Systems Architecture for Enterprise Application Integration). MIMOSA organization.

ISHM capability must integrate DLaK across physical, virtual, and discipline boundaries. This is not possible in an affordable manner unless standards are used to achieve plug&play and interoperability.



# ISHM Capability Development

## Standards for ISHM

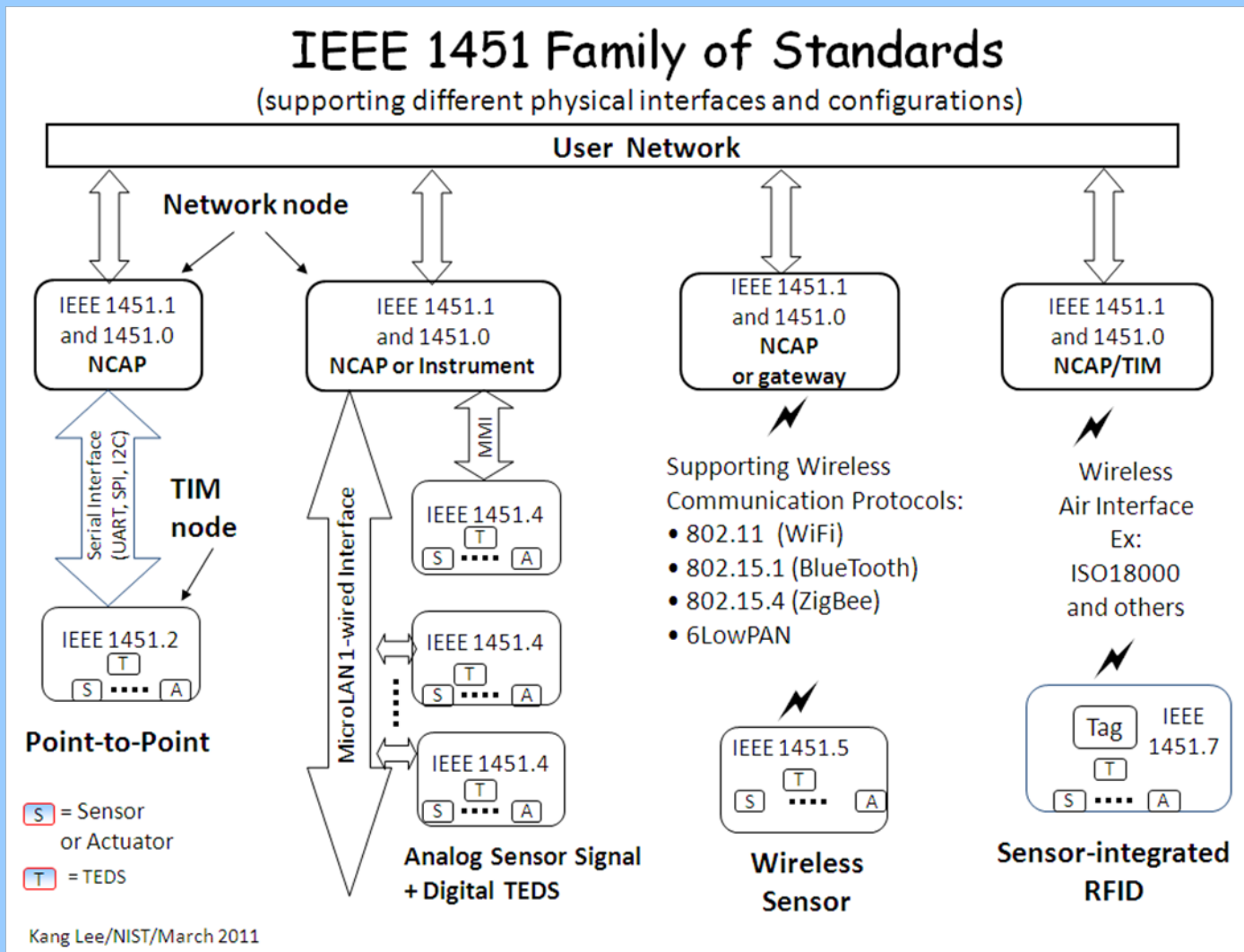

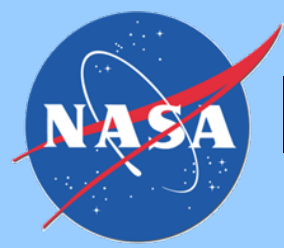

# ISHM Capability Development

## Standards for ISHM

### OSA-CBM (MIMOSA)



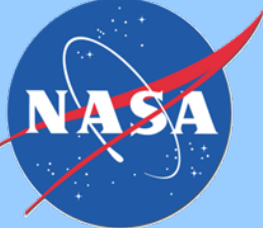

# ISHM Capability Development

## Standards for ISHM

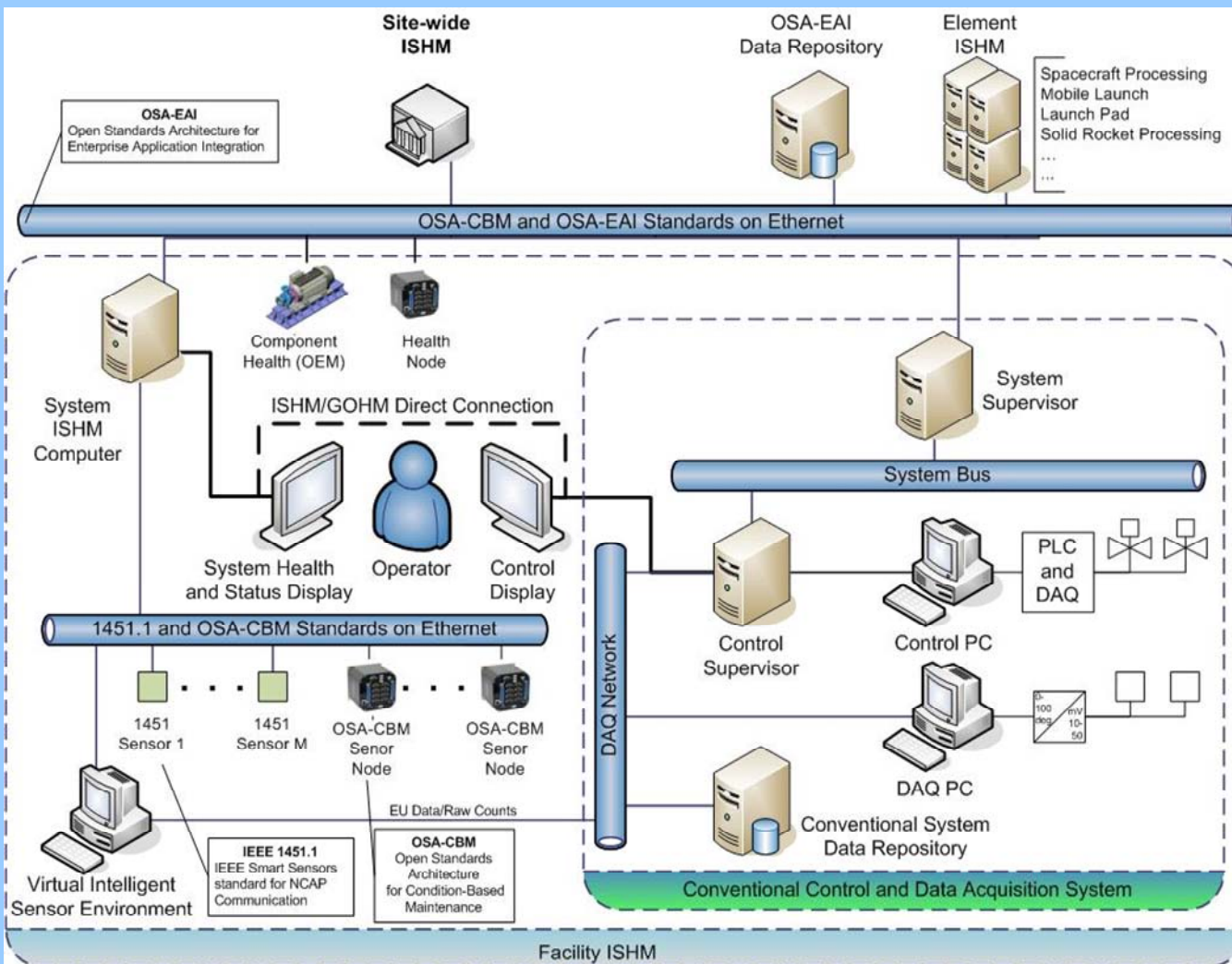

Architecture for pilot ISHM system implemented at NASA Kennedy Space Center, Launch Complex 20 (LC-20) showing the use of IEEE 1451.1, OSA-CBM, and OSA-EAI standards

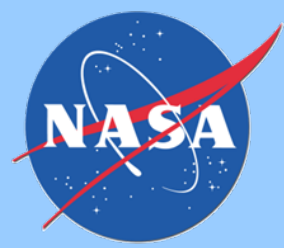

# Software to develop ISHM Domain Models (ISHM-DM's)

A software system for ISHM capability should support all core capabilities by integrating systematically DiaK through the ISHM-DM

- ***Object orientation***: object representation of system physical elements and associated process models is the best way to embed DiaK in a systematic and in an organized manner.
- ***Distribution of ISHM-DM's within and across networks***: ISHM-DM's might be distributed among processors connected to a network, simply because it is necessary to use parallel processing, and/or ISHM-DM's might be created by different people in various geographic locations

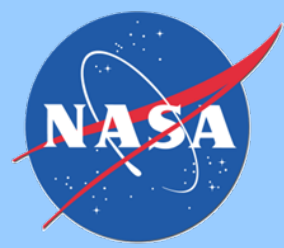

# Software to develop ISHM Domain Models (ISHM-DM's)

A software system for ISHM capability should support all core capabilities by integrating systematically DIaK through the ISHM-DM

- ***Distribution across processing units:*** Since multiple process models are expected to be running at any given time, the software environments should support parallel processing.
- ***Inference engine:*** Many tasks require an inference engine. Reasoning and decision making leading to anomaly detection, diagnostics, effects, and prognostics; require contextual integrity and cause-effect analysis using heterogeneous data and information.

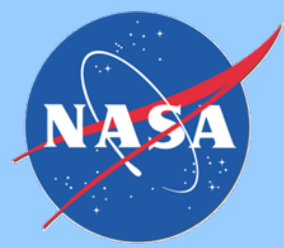

# Software to develop ISHM Domain Models (ISHM-DM's)

A software system for ISHM capability should support all core capabilities by integrating systematically DLaK through the ISHM-DM

- ***Integrated management of distributed DLaK:*** DLaK must be managed in a way to allow embodiment of systems thinking across elements and subsystems. Often this is enabled by definitions of relationships among elements of systems that can be physically visible (i.e. attached to, belong to a system); or more abstracted relationships, as it relates to involvement by groups of objects in process models.
- ***Definition of dynamic relationships among objects for use in reasoning:*** Often, the framework for reasoning and application of process models changes dynamically with configuration changes, stages of operation, etc.

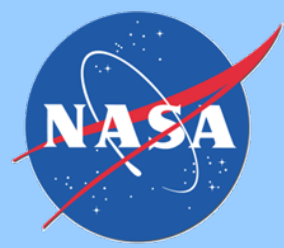

# Software to develop ISHM Domain Models (ISHM-DM's)

A software system for ISHM capability should support all core capabilities by integrating systematically DLaK through the ISHM-DM

- ***Iconic representation of systems objects with visible and virtual links (relationships) used to provide intuitive representation of reasoning and context.*** The mix of object orientation and iconic representation of DLaK provides the ability to intuitively visualize interrelationships and dig deep into details of the ISHM system. As complexity increases, graphical programming and visualization become essential.





# CSG ISHM Domain Model: User Interfaces

Telewindows Client

File Edit View Layout Go Project Workspace Tools Window Help

Enter Test Parameters IRIG TO Time: 2009:167:12:33:54:883:5 Current Relative Test Time: 2.044 Start Test Sequence Menu User Mode Developer Simulation A RC M L Ready

**Bluelines**

- PT-14A31-GN
- PE-14A2435-HD
- PE-14A2215-CW
- TC-14A4046-LO
- TC-14A4040-LO
- TT-14A16-LO
- PE-14A4185-GN
- PE-14A4183-GN
- PE-14A4184-GN
- PE-14A26-LO
- PE-14A4023-GO
- PE-14A4192-GN
- PE-14A4191-GN
- PE-14A4190-GN
- PE-14A34-IPA
- PT-14A23-GN

**Redlines**

- PDE-14A4086-S
- PE-14A26-LO
- TT-14A16-LO
- PE-14A34-IPA
- PE-14A4131-S
- PE-14A2435-HD
- PE-14A2215-CW
- TC-14A4128-S
- TC-14A4126-S
- PE-14A4117-IPA
- PE-14A4084-CW
- PE-14A4023-GO

**Blueline Active Monitors**

**Redline Active Monitors**

**Blueline Alarm Queues**

**Redline Alarm Queues**

**Transducer Electronic Data Sheet Viewing Windows**

**EDS Explorer**

By Component..

EDS List

- PE-14A4052-LO
- TEDS
- Basic TEDS
- Bridge Sensor

**EDS Attributes**

Bridge Element Impedance (Ω)	351
Bridge Type	Full
Calibration Date	2009-04-21
Calibration Period	365
Calibrator's Initials	CA
Electronic Datasheet Name	Bridge Sensor
Full Scale Electrical Value Precision	mV/V
IEEE 1451.4 Template ID	33
Mapping Method	Linear
Maximum Electrical Output (V/V)	3.034
Maximum Excitation Level (V)	15
Maximum Physical Value	1000
Measurement Location ID	4052
Minimum Electrical Output (V/V)	0.015
Minimum Excitation Level (V)	10
Minimum Physical Value	0
Nominal Excitation Level (V)	10
Physical Measurand	psi
Read/Write Access	Read/Write
Response Time (S)	0.1
Transducer Electrical Signal Type	Bridge Sensor

**BLUELINE-ALARM-QUEUE**

Target	Message	Priority	Repetitions	Detail
Pe-14a2435-Hd	ACHIEVED - 2009/06/16 12:31:37.406 p.m.	1	1	HYDRAULIC PRESSURE
Tt-14a16-Lo	ACHIEVED - 2009/06/16 12:31:37.406 p.m.	1	1	LOX RUN TANK TEMPERATURE
Pt-14a23-Gn	ACHIEVED - 2009/06/16 12:31:37.406 p.m.	1	1	UHP GN BOTTLE TANK PRESSURE (LOX PRESS)
Pe-14a4183-Gn	ACHIEVED - 2009/06/16 12:31:37.406 p.m.	1	1	1st STAGE GOX PURGE PRESSURE
Pe-14a4184-Gn	ACHIEVED - 2009/06/16 12:31:37.406 p.m.	1	1	2nd STAGE LOX S/D PURGE PRESSURE
Pe-14a4185-Gn	ACHIEVED - 2009/06/16 12:31:37.406 p.m.	1	1	MAIN STAGE LOX S/D PURGE PRESSURE
Pe-14a4023-Go	ACHIEVED - 2009/06/16 12:31:37.406 p.m.	1	1	GOX SUPPLY PRESSURE

**REDLINE-ALARM-QUEUE**

Target	Message	Priority	Repetitions	Detail
Pe-14a4117-IPA	EXCEEDED - 2009/06/16 12:33:56.967 p.m.	1	1	Loss of IPA Main Stage Interface Pressure

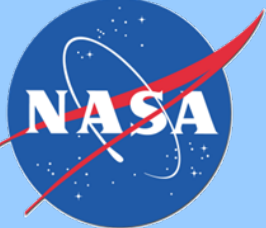

# CSG ISHM Domain Model: Blueline/Redline User Interfaces

Telewindows Client

File Edit View Layout Go Project Workspace Tools Window Help

Enter Test Parameters (RIG TO Time): 2009:167:12:33:54:883:5 Current Relative Test Time: 2.044 Start Test Sequence Menu User Mode Developer Simulation A RC M L Ready

**Bluelines**

- PT-14A31-GN
- PE-14A2435-HD
- PE-14A2215-CW
- TC-14A4046-LO
- TC-14A4040-LO
- TT-14A16-LO
- PE-14A4185-GN
- PE-14A4183-GN
- PE-14A4184-GN
- PE-14A26-LO
- PE-14A4023-GO
- PE-14A4192-GN
- PE-14A4191-GN
- PE-14A4190-GN
- PE-14A34-IPA
- PT-14A23-GN

**Blueline Details**

PE-14A4192-GN  
Last Reading Gathered: 591.431  
MAIN STAGE IPA S/D PURGE PRESSURE

Low: 525.0

Event Name	Event Time
ACHIEVED	2009/06/16 11:29:24.814978

**Blueline Configuration**

PE-14A4183-GN  
Last Reading Gathered: 585.691  
1st STAGE GOX PURGE PRESSURE

Low: 525.0

High Blueline Parameters

Enabled	Settings	Description
<input type="checkbox"/>	0 psi	1st STAGE GOX PURGE PRESSURE

Low Blueline Parameters

Enabled	Settings
<input checked="" type="checkbox"/>	525.000 psi

Blueline Details and Configuration User Interfaces

**Redlines**

- FDE-14A4086-S
- PE-14A26-LO
- TT-14A16-LO
- PE-14A34-IPA
- PE-14A4131-S
- PE-14A2435-HD
- PE-14A2215-CW
- TC-14A4128-S
- TC-14A4126-S
- PE-14A4117-IPA
- PE-14A4084-CW
- PE-14A4023-GO

**Redline Details Dialog**

Maximum Settings

Arm Time: 0.0  
Disarm Time: 0.0

Condition: Enter High Red Line Condition Here.

Minimum Settings

Arm Time: 2.0  
Disarm Time: 14.0

Condition: Loss of IPA Main Stage Interface Pressure

Event Name: EXCEEDED  
Event Time: 2009/06/16 12:33:56.967 p.m.

**Redline Configuration**

PE-14A4084-CW  
Last Reading Gathered: 1.816

Low: 40.0

Maximum Redline Parameters

Enabled	Settings	Arm Time	Disarm Time	Condition
<input type="checkbox"/>	0 psi	T <sub>0</sub> 0	T <sub>0</sub> 0	Enter High Red Line Condition Here.

Minimum Redline Parameters

Enabled	Settings	Arm Time	Disarm Time	Condition
<input checked="" type="checkbox"/>	40.000 psi	T <sub>0</sub> -35.000	T <sub>0</sub> 14.000	Loss of Igniter Stage CW

Redline Details and Configuration User Interfaces

EDS Explorer EDS Attributes

BLUETIME-ALARM-QUEUE REDLINE-ALARM-QUEUE



# CSG ISHM Domain Model: Redline Event Handling

Telewindows Client

File Edit View Layout Go Project Workspace Tools Window Help

Enter Test Parameters IRIG TO Time: 2009:167:12:33:54:883:5 Current Relative Test Time: 2.044 Start Test Sequence Menu User Mode Developer Simulation A RC M L Ready

### G2 Redlines Anomaly Report

**Redline Anomaly Details**

Sensor Name	PE-14A4117-IPA
Event Type	EXCEEDED
Main Threshold Limit	210.0 psi
Event Time	2009/06/16 12:33:56.967 p.m.
Event Time to TO	2.084
Auto Time	2.0
Drain Time	14.0
Condition	Loss of IPA Main Stage Interface Pressure
Test Name	0911_021A_9167_CSGT
Test TO Time	2009/06/16 12:33:54.883 p.m.
Auto-sequence Start Time	-37.0
Auto-sequence End Time	14.0

**PE-14A4117-IPA**  
Redline EXCEEDED at: 2009/06/16 12:33:56.967 p.m.

**CSG Unit #1**

**Navigation to Transducer Where Redline Event Occurred**

### BLUELINE-ALARM-QUEUE

Target	Message	Priority	Repetitions	Detail
Pe-14a2435-Hd	ACHIEVED - 2009/06/16 12:31:37.406 p.m.	1	1	HYDRAULIC PRESSURE
Tt-14a16-Lo	ACHIEVED - 2009/06/16 12:31:37.406 p.m.	1	1	LOX RUN TANK TEMPERATURE
Pt-14a23-Gn	ACHIEVED - 2009/06/16 12:31:37.406 p.m.	1	1	UHP GN BOTTLE TANK PRESSURE (LOX PRESS)
Pe-14a4183-Gn	ACHIEVED - 2009/06/16 12:31:37.406 p.m.	1	1	1st STAGE GOX PURGE PRESSURE
Pe-14a4184-Gn	ACHIEVED - 2009/06/16 12:31:37.406 p.m.	1	1	2nd STAGE LOX S/D PURGE PRESSURE
Pe-14a4185-Gn	ACHIEVED - 2009/06/16 12:31:37.406 p.m.	1	1	MAIN STAGE LOX S/D PURGE PRESSURE

### REDLINE-ALARM-QUEUE

Target	Message	Priority	Repetitions	Detail
Pe-14a4117-IPA	EXCEEDED - 2009/06/16 12:33:56.967 p.m.	1	1	Loss of IPA Main Stage Interface Pressure

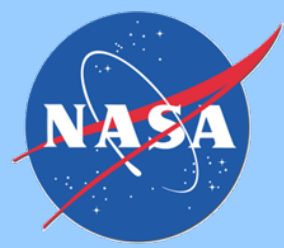

# Failures Modes and Effects Analysis (FMEA)

## MIL-STD-1629A(2) NOT 3

ID #	Item-Functional Identification	Function	Failure Modes and Causes	Mission Phase-Operational Mode	Failure Effects		Failure Detection Method
					Local End Effects Effects	Next Higher Level	
	Process Equipment	Fluid feed subsystem	Leak	Sealed subsystem maintaining pressure	Pressure leak	Decreasing pressure measurement	Identify sealed subsystem, and check pressure sensors for decreasing pressure.

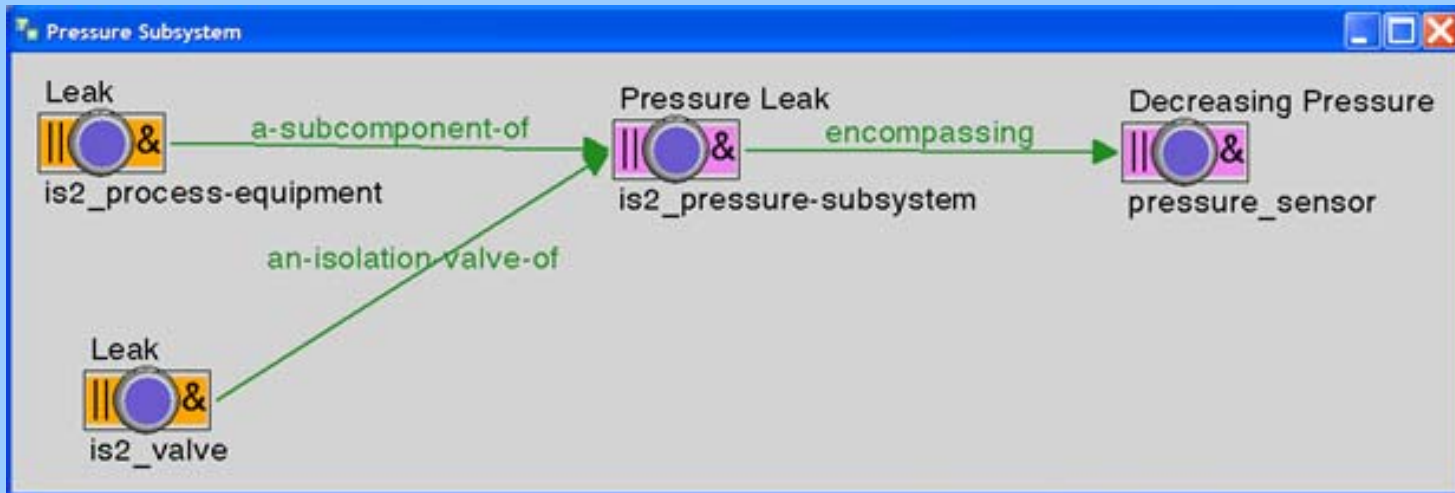



# ISHM Capability Development

## Intelligent Sensors and Components

### Smart Sensor/Actuator (NIST)

*“The IEEE (Institute of Electrical and Electronics Engineers) 1451 smart transducer interface standards provide the common interface and **enabling technology for the connectivity of transducers to microprocessors, control and field networks, and data acquisition and instrumentation systems**. The standardized TEDS specified by IEEE 1451.2 allows the **self-description** of sensors and the interfaces provide a **standardized mechanism to facilitate the plug and play of sensors to networks**. The network-independent smart transducer object model defined by IEEE 1451.1 allows sensor manufacturers to support multiple networks and protocols. Thus, **transducer-to-network interoperability** is on the horizon. The inclusion of P1451.3 and P1451.4 to the family of 1451 standards will meet the needs of the analog transducer users for high-speed applications. In the long run, transducer vendors and users, system integrators and network providers can all benefit from the IEEE 1451 interface standards [1].”*

“Intelligent Sensor” is a “Smart Sensor” with the ability to provide the following functionality: (1) measurement, (2) measure of the quality of the measurement, and (3) measure of the “health” of the sensor. The better the sensor provides functionalities 2 and 3, the more intelligent it is.

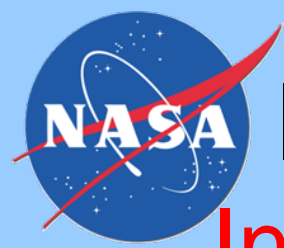

# ISHM Capability Development

## Intelligent Sensors and Components

### Typical Process Models for Sensors

- Noise Level Assessment and History
- Spike Detection and History
- Flat Signal Detection and History
- Response Time Characterization
- Intermittency Characterization and History
- Physical Detachment Characterization and History
- Regime Characterization and History
- Curve Fit on Identified Regimes

“Intelligent Sensor” is a “Smart Sensor” with the ability to provide the following functionality: (1) measurement, (2) measure of the quality of the measurement, and (3) measure of the “health” of the sensor. The better the sensor provides functionalities 2 and 3, the more intelligent it is.



# ISHM Capability Development

## Intelligent Sensors and Components

### Example Intelligent Sensor Implementations

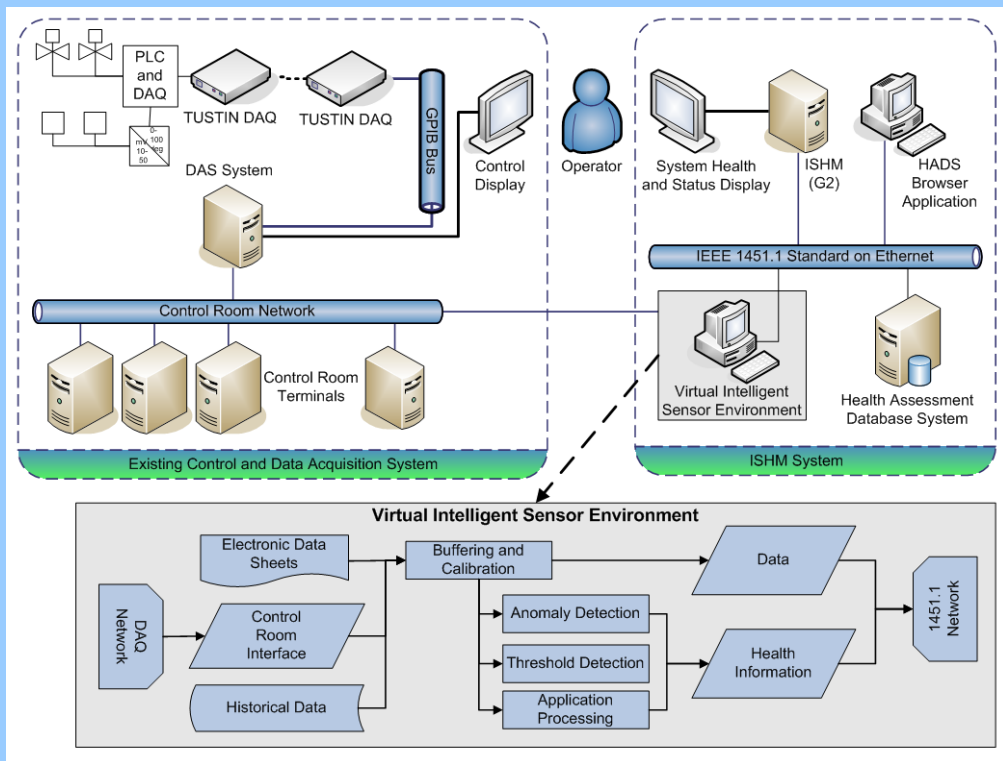

The Virtual Intelligent Sensor Environment (VISE) converts all classic sensors installed in a rocket engine test stand into “intelligent sensors.”

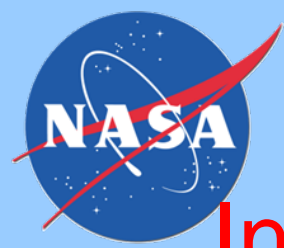

# ISHM Capability Development

## Intelligent Sensors and Components

### Example Intelligent Sensor Implementations



Mobitrum

[www.mobitrum.com](http://www.mobitrum.com)



Smart Sensor Systems

[www.smartsensorsystems.com](http://www.smartsensorsystems.com)



NIST

[www.mel.nist.com](http://www.mel.nist.com)



Esensors

[www.eesensors.com](http://www.eesensors.com)



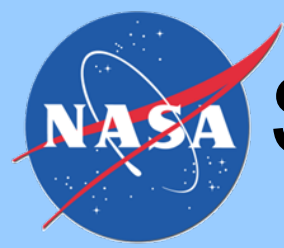

# Sensor selection and Placement for ISHM

- When developing an ISHM capability from the ground up, one must optimize sensor suites to achieve maximum functional capability (anomaly detection, diagnosis, effects, prognostics).

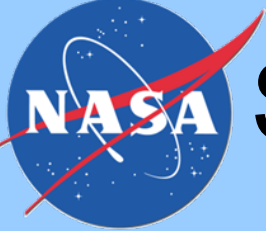

# Sensor selection and Placement for ISHM

Systematic Sensor Selection Strategy (S4) is a model-based procedure for systematically and quantitatively identifying the sensor compliment that optimally achieves the health assessment goals of a system (Reference 14 of the paper).

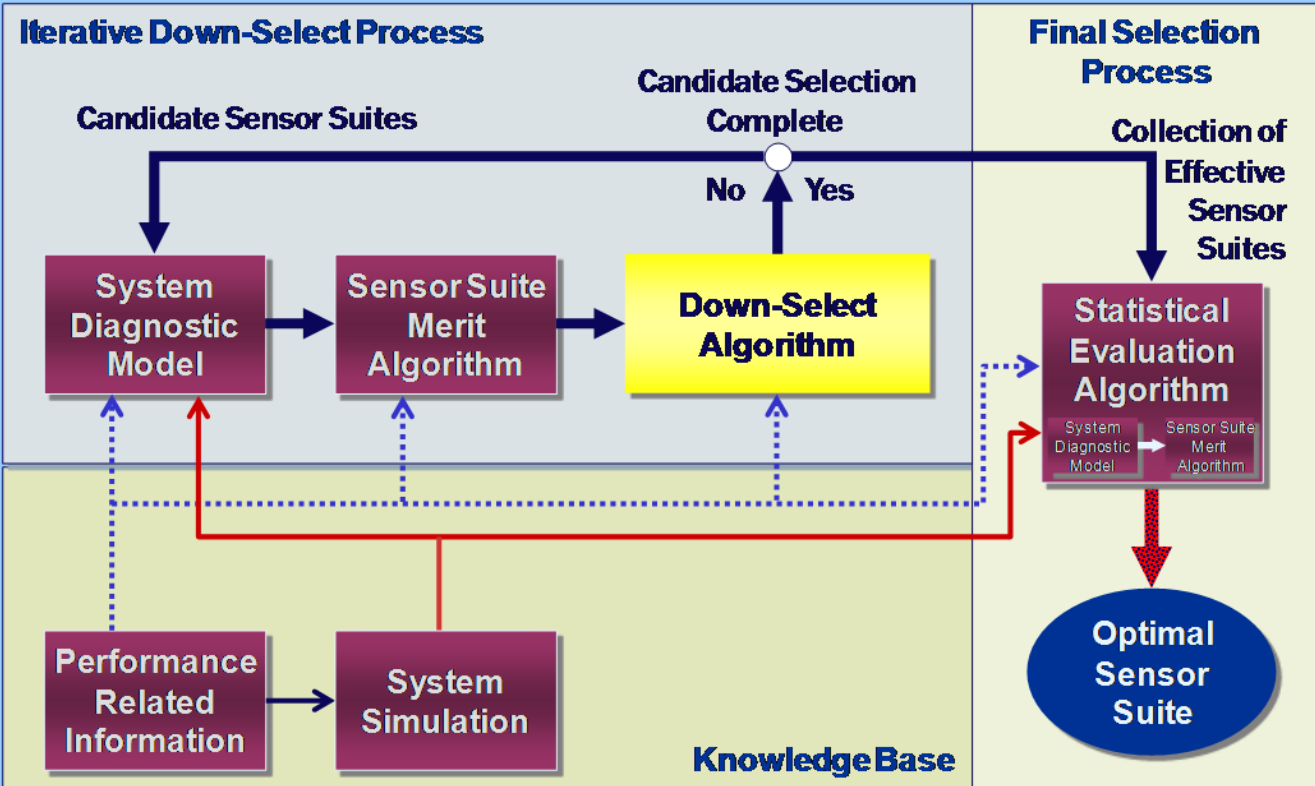

Application Specific Non-Application Specific

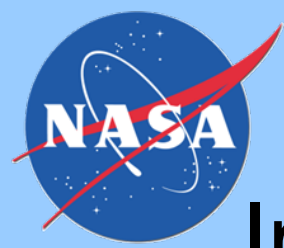

# ISHM in Systems Design, Integration, and Engineering (SDI&E)

- SDI&E practices are employed to build complex systems.
- SDI&E for aerospace systems has developed into its own discipline, although theories and concepts have not been adequately formalized in an academic sense.
- The role of ISHM in SDI&E is linked to the concept of ISHM-DM's, whereby every element that is part of a system comes with its own ISHM-DM that can be rolled-up into an overall system ISHM-DM in a plug&play approach.
- When two elements are assembled, the ISHM-DM of each element is incorporated into the ISHM-DM of the assembly. In this manner, DIaK compartmentalized in each element becomes immediately available and useful to the ISHM-DM of the assembly.

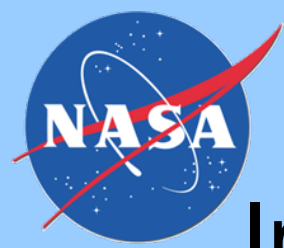

# ISHM in Systems Design, Integration, and Engineering (SDI&E)

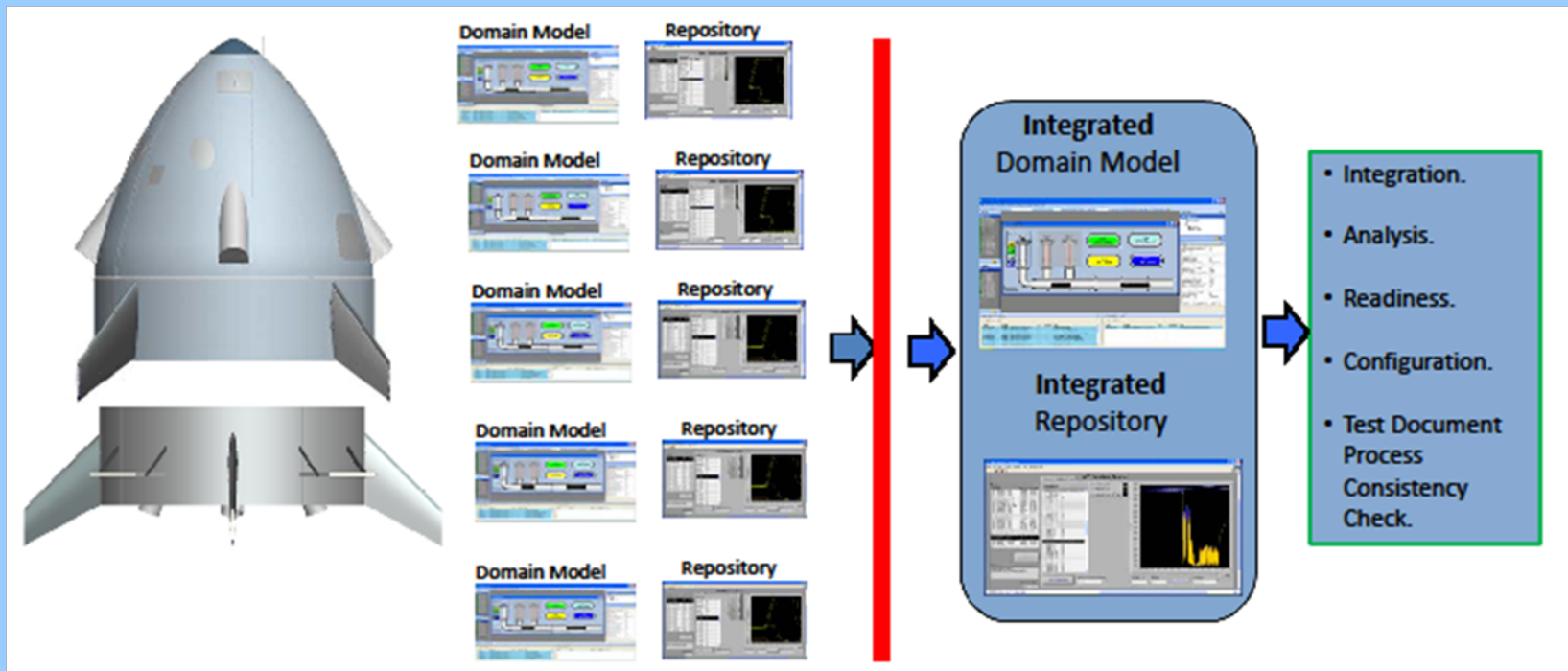

ISHM concept for systems integration of ISHM-DM's

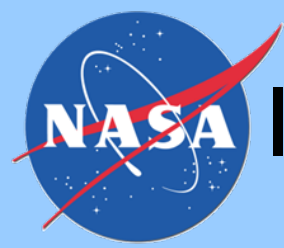

# Intelligent Control for ISHM-Enabled Systems

- Control of complex systems that are ISHM-enabled is a nascent area, simply because ISHM itself is also relatively new.
- The objective is for the control function to make use of system health information in order to achieve its objectives.

The paradigm implies that control systems become users of health information, while at the same time making use of actuators to help further improve determination of the system health

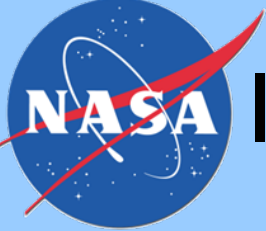

# Intelligent Control for ISHM-Enabled Systems

Example Application (Reference 18 of the paper)

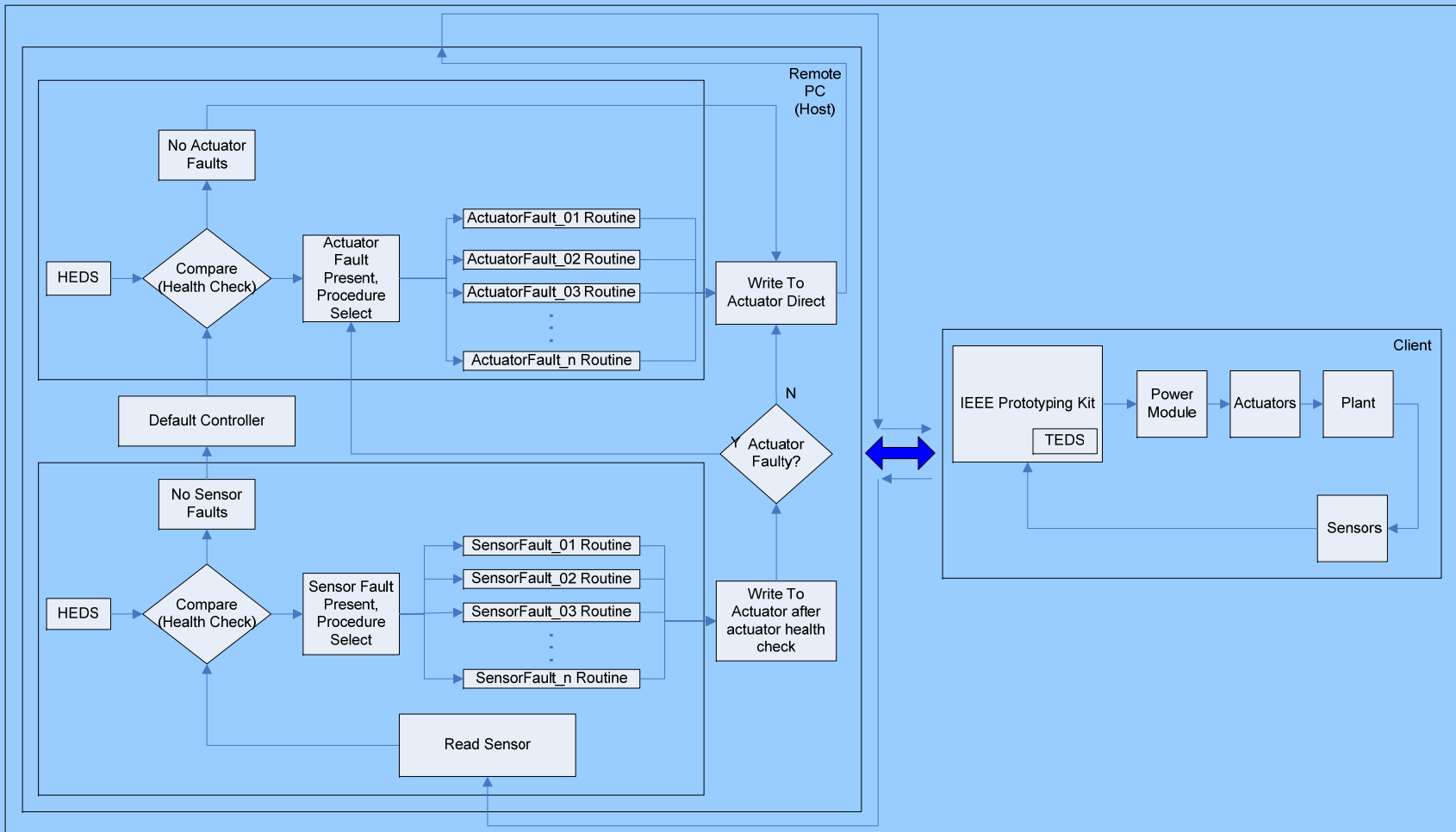

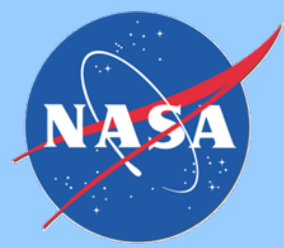

# Verification and Validation Considerations for ISHM

The need to use knowledge, and hence inference engines; and the complexities of parallel processing and reconciliation of potentially inconsistent outcomes that lead to anomaly determination; requires advances in verification and validation of the ISHM capability itself

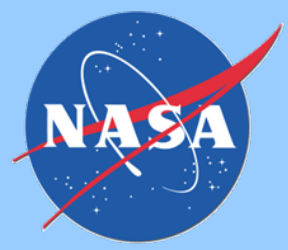

# Backup Slides



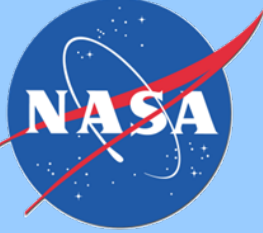

# Health Assessment Database System HADS

- Health Electronic Data Sheets (HEDS)
- Repository of anomalies and algorithms
- Transducer Electronic Data Sheets (TEDS)
- Historical test data and analysis results
- Provides ease of data analysis and data trending

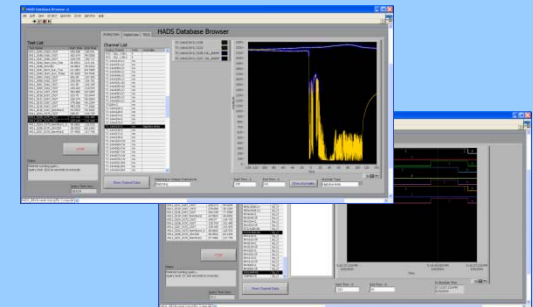
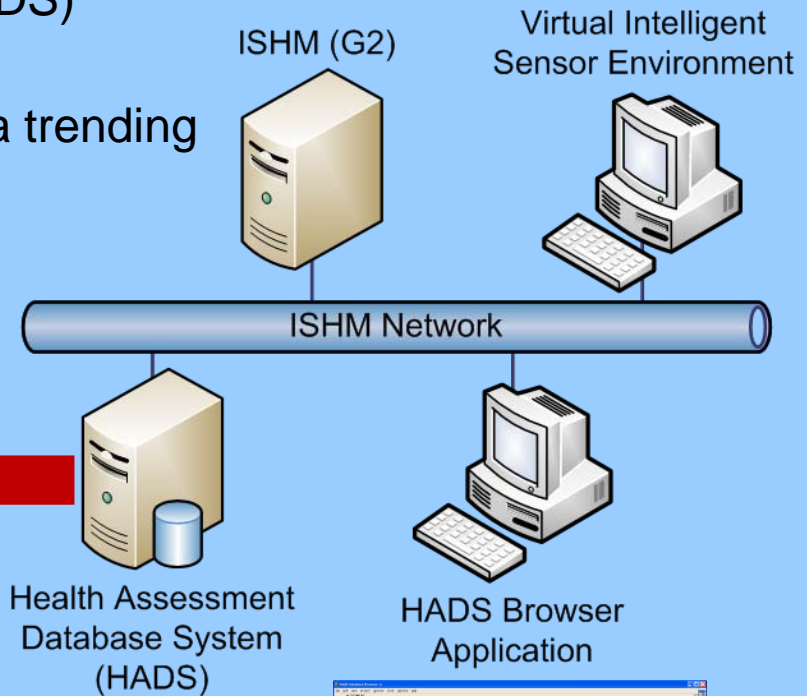
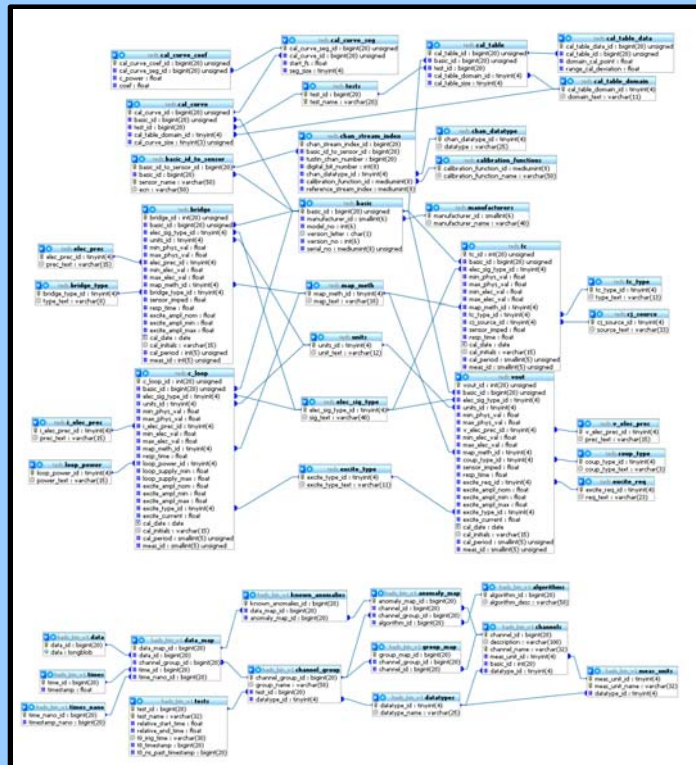

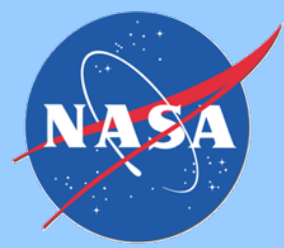

# HADS Browser Application

## HADS Browser Capabilities

- Allows longitudinal analyses and comparisons with previous test results
- Viewing usage statistics on monitored elements
  - cycle times on valves
  - mean time to failure
- Viewing anomalous events/data trends
- Viewing TEDS

Test Name	Start Time	End Time
0911_0194_9160_CSGT	-305.650	100.541
0911_0196_9160_CSGT	-362.674	99.5208
0911_0197_9160_CSGT	-225.070	100.717
4911_0194_Norm_Run_One	+20.0521	114.141
4911_0196_ADV250	+18.9601	+5.2323
4911_0197_Norm_Run_Two	+21.1961	84.7965
4911_0190_Norm_Run_Three	+29.4202	84.7646
0911_020A_9162_CSGT	+302.99	107.405
0911_020B_9162_CSGT	+239.294	134.701
0911_020C_9162_CSGT	+311.05	122.145
0911_020D_9162_CSGT	+246.462	119.533
0911_021A_9167_CSGT	-304.866	69.3285
0911_021B_9167_CSGT	-223.75	52.6444
0911_021C_9167_CSGT	-226.074	56.9204
0911_021D_9167_CSGT	-278.066	46.1294
0911_021E_9167_CSGT	-393.239	77.1566
4911_021D_9167_NormRun3	-43.5923	40.4002
0911_022A_9170_CSGT	-345.07	134.725
0911_022B_9170_CSGT	-135.709	151.485
0911_022C_9170_CSGT	-129.445	141.949
4911_022A_9170_NormRun1_0	-36.6602	122.533
4911_022B_9170_ADV250	-38.0522	60.1404
4911_022C_9170_NormRun2	-37.4482	117.745

Channel	TEDS Field	TEDS Value
PE-14A4109-IPA		
PE-14A4117-IPA		
PE-14A4192-ON	Manufacturer Name	Stellar Technology
PE-14A4191-ON	Model Number	2000
PE-14A4190-ON	Version Letter	G
PE-14A4189-ON	Version Number	121
PE-14A4189-ON	Serial Number	966546
PE-14A4025-OO		
PE-14A4010A-O		
PDE-14A4273-IPA	Transducer Electrical Signal Type	Bridge Sensor
PE-14A4047-O	Physical Measurement	psi
PE-14A4026-OO	Minimum Physical Value	0
	Maximum Physical Value	2000
	Full Scale Electrical Value Precision	mV/V
PE-14A4044-O	Minimum Electrical Output	0.007
PE-14A4052-O	Maximum Electrical Output	3.022
PE-14A4034-OO	Mapping Method	Linear
PE-14A4185-ON	Bridge Type	Full
PE-14A4184-ON	Bridge Element Impedance	351.1
PE-14A4183-ON	Response Time	0.1
PE-14A4131-S	Excitation Level, Nominal	10
PE-14A4133-S	Excitation Level, Minimum	10
PE-14A4135-S	Excitation Level, Maximum	15
PE-14A4127-S	Calibration Date	2/4/2009
PE-14A4172-S	Calibration Initials	CA
PE-14A4141-S	Calibration Period	180
PE-14A4140-S	Measurement Location ID	4032
PDE-14A4086-S		
PE-14A4262-O		
PE-14A4119-IPA		
PE-14A4075-CW		
PE-14A4090-IPA		
PE-14A4201-IPA		
PDE-14A2030-IPA		
ISVI-CURA		

Digit Data - Data to multiple channels

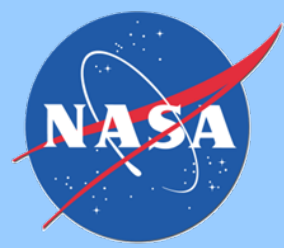

# CSG ISHM Domain Model: Top Layer View

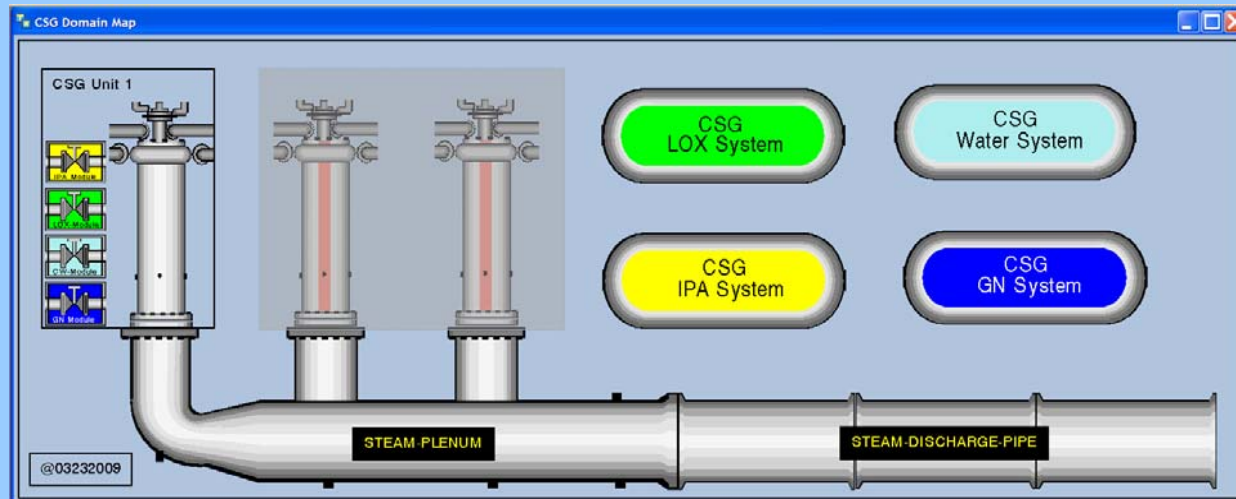

ISHM Domain  
Model  
Top Layer

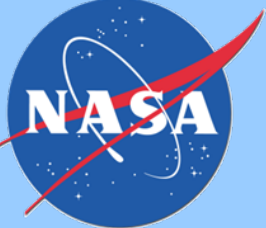

# CSG ISHM Domain Model: Transducer Data Plots

Telewindows Client

File Edit View Layout Go Project Workspace Tools Window Help

Enter Test Parameters (IRIG TO Time): 2009:167:12:33:54:883:5 Current Relative Test Time: 2.044 Start Test Sequence Menu User Mode Developer Simulation A RC M L Ready

**Bluelines**

- PT-14A31-GN
- PE-14A2435-HD
- PE-14A2215-CW
- TC-14A4046-LO
- TC-14A4040-LO
- TT-14A16-LO
- PE-14A4185-GN
- PE-14A4183-GN
- PE-14A4184-GN
- PE-14A26-LO
- PE-14A4023-GO
- PE-14A4192-GN
- PE-14A4191-GN
- PE-14A4190-GN
- PE-14A34-IPA
- PT-14A23-GN

**Redlines**

- FDE-14A4086-S
- PE-14A26-LO
- TT-14A16-LO
- PE-14A34-IPA
- PE-14A4131-S
- PE-14A2435-HD
- PE-14A2215-CW
- TC-14A4128-S
- TC-14A4126-S
- PE-14A4117-IPA
- PE-14A4084-CW
- PE-14A4023-GO

**CSG 1 IPA Interface Module**

**IPA Primary Distribution Module**

Streaming data plots from selected sensors

**PE-14A4044-LO** Real-Time Plot of PE-14A4044-LO

**TC-14A4053-LO** Real-Time Plot of TC-14A4053-LO

**PE-14A4117-IPA** Real-Time Plot of PE-14A4117-IPA

**TC-14A4108-IPA** Real-Time Plot of TC-14A4108-IPA

BLUELINE-ALARM-QUEUE REDLINE-ALARM-QUEUE

EDS Explorer EDS Attributes

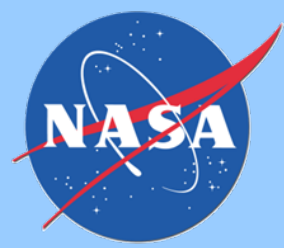

# CSG Anomalies Detected

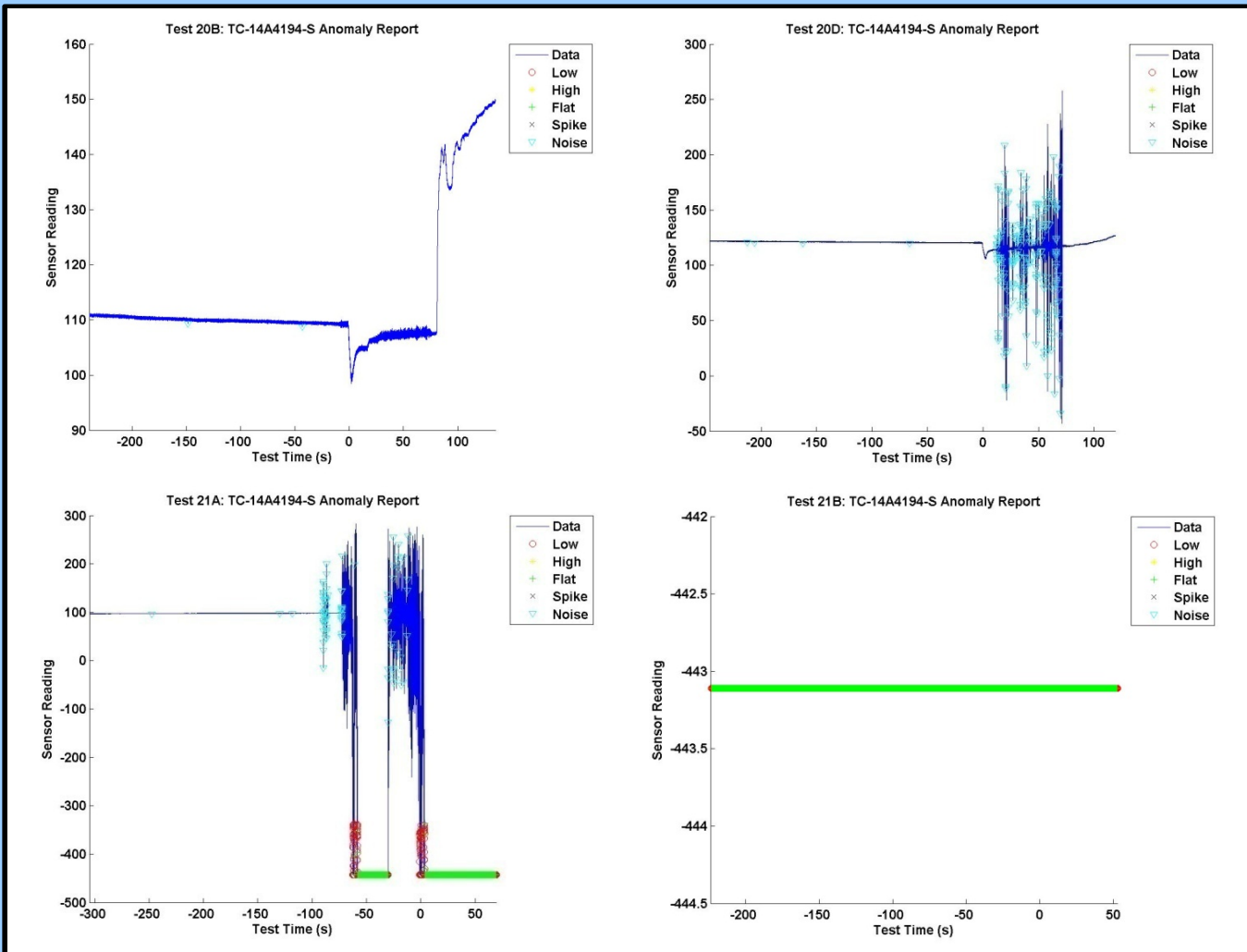

- Evidence of TC degradation detected by VISE anomaly detection
- Advanced notification to determine the health of the whole system before beginning a test

Transducer Anomaly Report Graphs for one sensor in four consecutive tests.

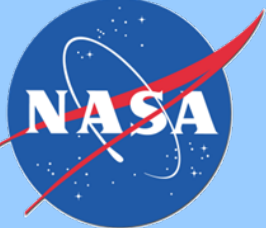

# Elements of an ISHM System: ISHM Model - Proximate Cause Analysis

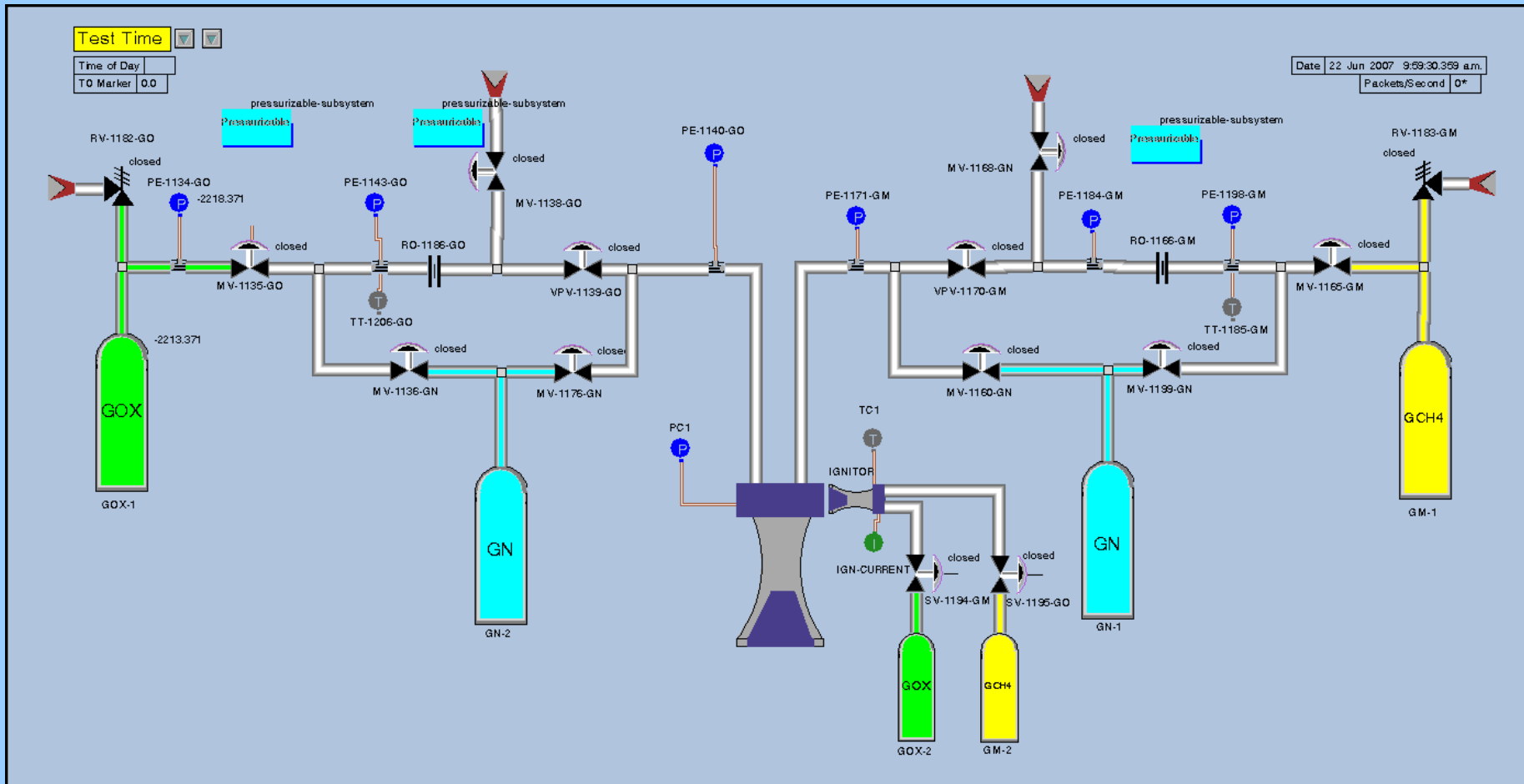

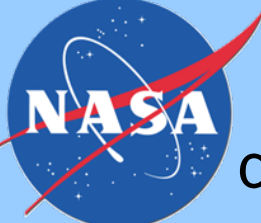

# Expanded causal-directed graph generated by the detection of a leak in the subsystem where a valve was opened manually (injected leak)

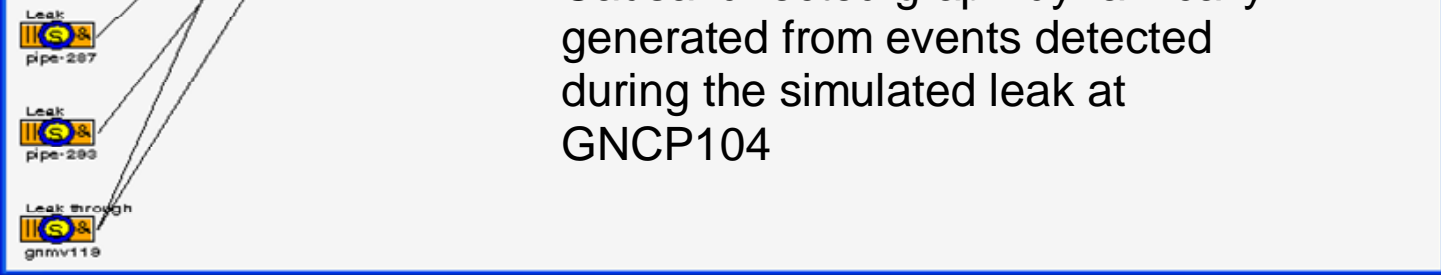
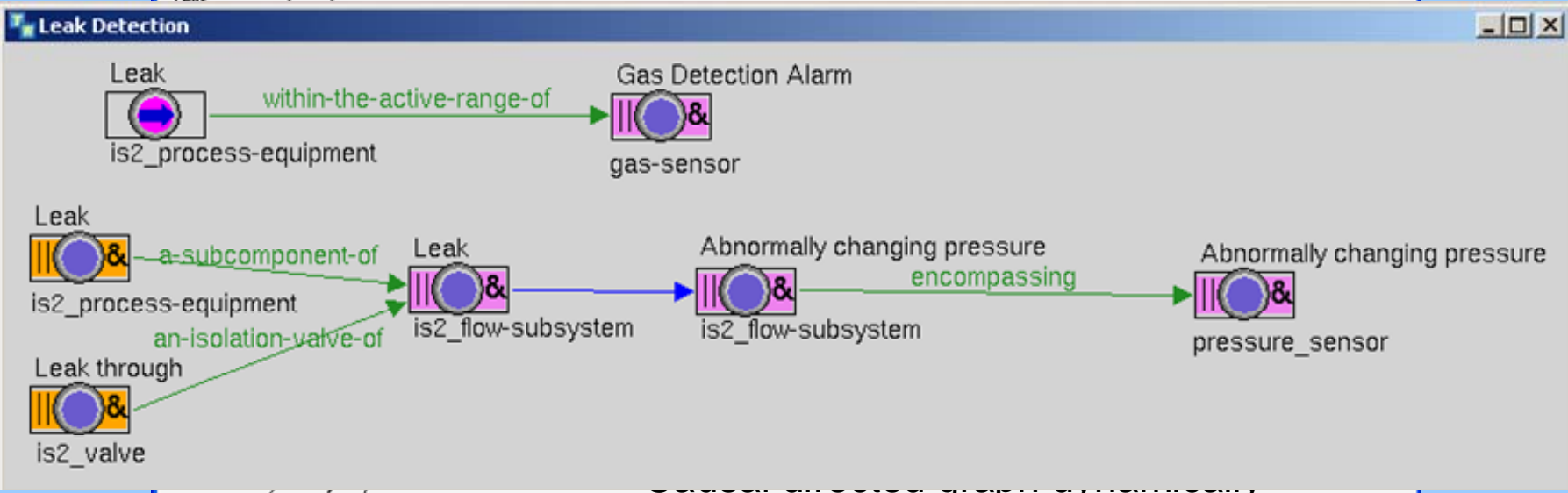
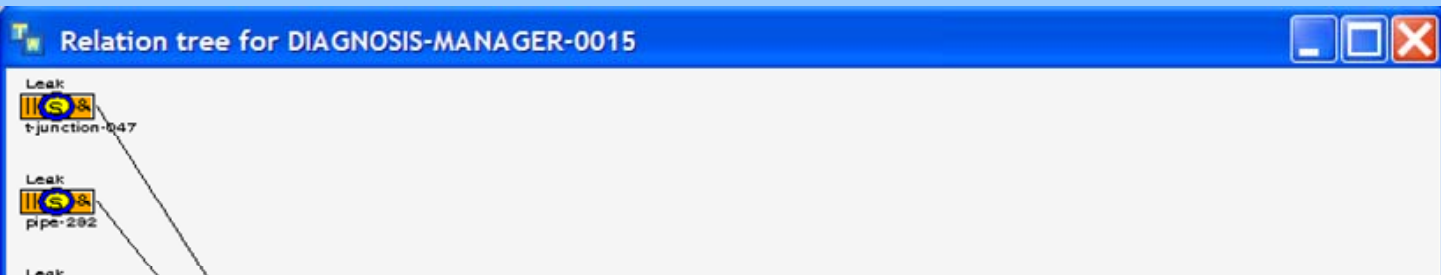

generated from events detected during the simulated leak at GNCP104

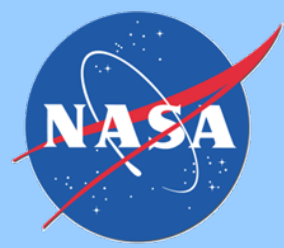

# List of Anomaly Detection Capabilities

Anomaly/Behavior	Demonstrated Cause	Detection Approach
Leaks (pipes, valves, etc.)	Various	Checking for pressure leaks using the concept of Pressure Subsystems.
Valve state undetermined	Defective feedback sensor Controller failure	Determines valve state by checking consistency of command, feedback, open/close switches, and pressure conditions upstream and downstream.
Valve oscillation	Fluid contamination in hydraulic supply	Compare running standard deviation of command versus feedback.
Valve stuck	Fluid contamination in hydraulic supply Seat seizure	Feedback remains horizontal while command changes.
Excessive noise, spikes, etc.	Interference	Running standard deviation exceeds set limits. Thresholds violations during short time spans (compared to sensor time-constant).
Degradation	Wear, aging	Trend detection using curve fitting and determination of time-constants.
Prediction-Measurement mismatch	Various	Use predictive model (e.g. from Modeling & Analysis Group) to predict sensor values and compare with measurements.



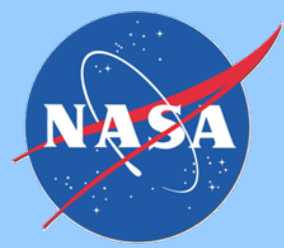

# Short-Time Fourier Transform Segmentation

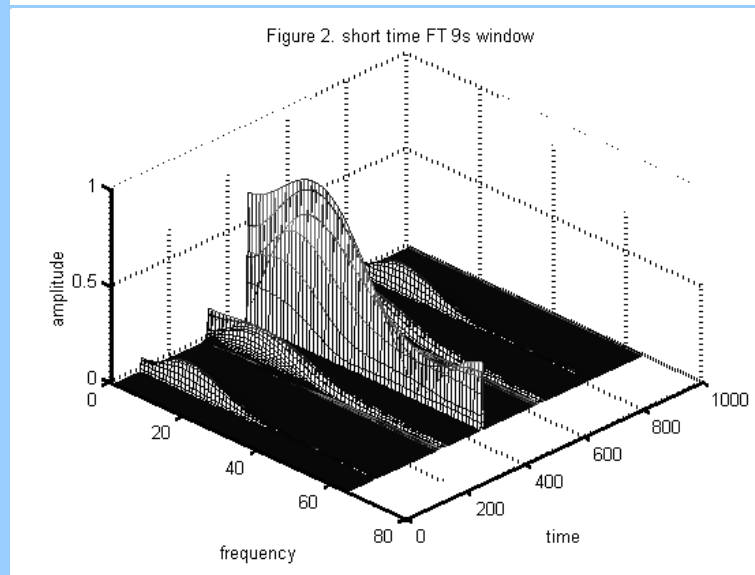
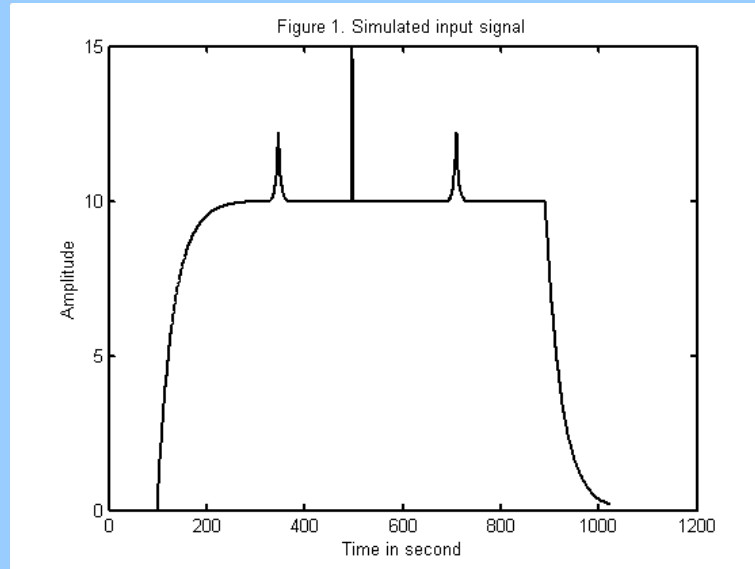

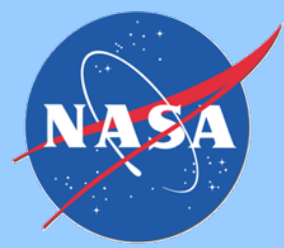

# Determining Valve-State

Valve State	Command	Feedback	Open limit	Closed Limit	Associated Sensors
<b>Open</b>	Open	Open	True	False	Agree with model
	Healthy				
<b>Closed</b>	Closed	Closed	False	True	Agree with Model
	Healthy				

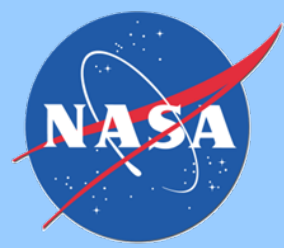

# Checking for Pressure Leaks

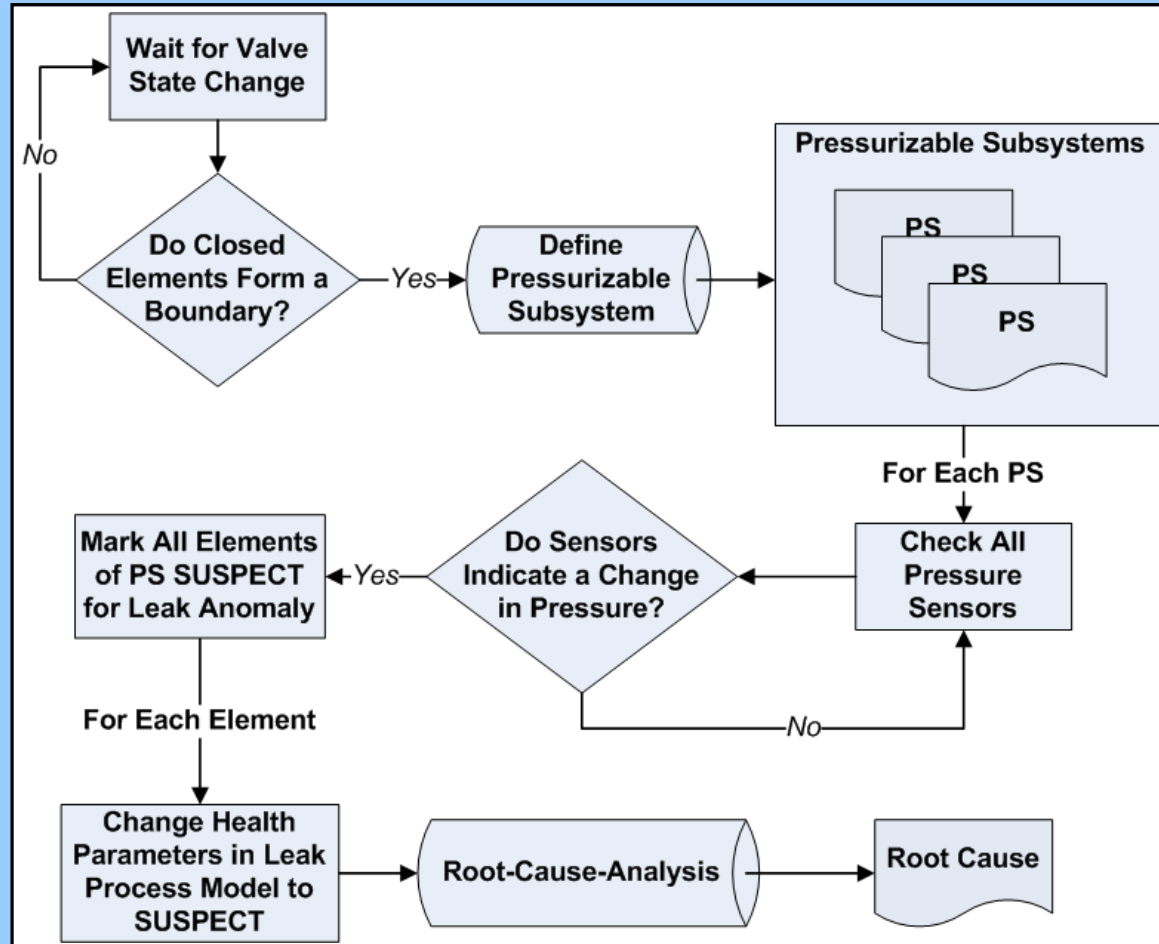

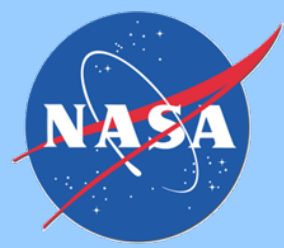

# Runtime Predictive Modeling

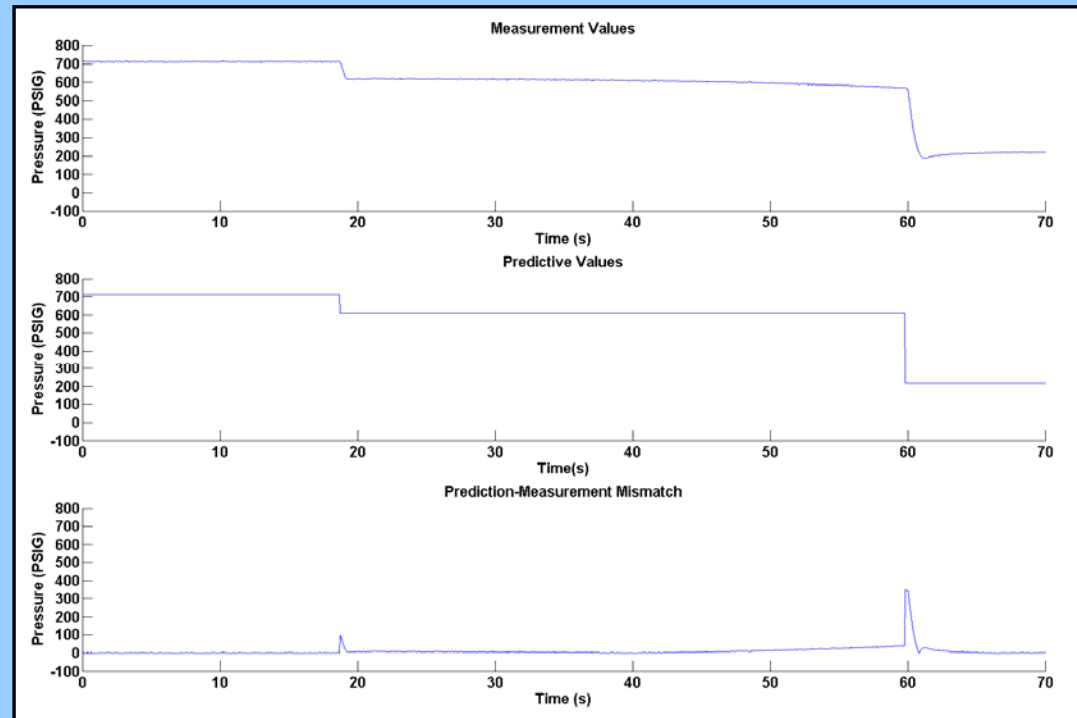
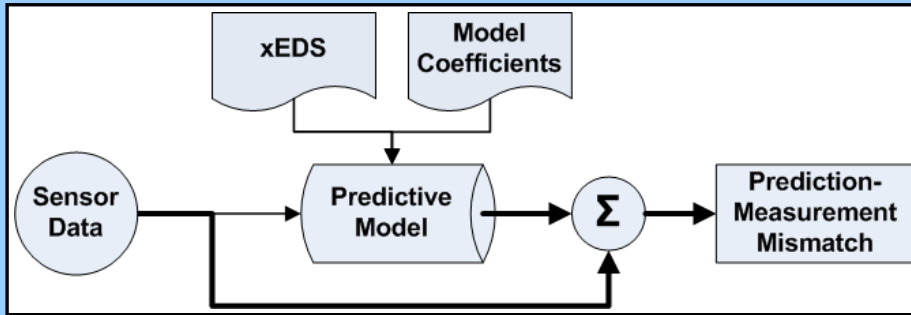

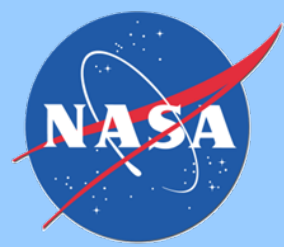

# Intelligent Sensors

- Smart sensor
  - NCAP (Go Active, Announce)
  - Publish data
  - Set/Get TEDS
- Intelligent sensor
  - Set/Get HEDS
  - Publish health
- Detect classes of anomalies using:
  - Using statistical measures
    - Mean
    - Standard deviation
    - RMS
  - Polynomial fits
  - Derivatives (1<sup>st</sup>, 2<sup>nd</sup>)
  - Filtering—e.g., Butterworth HP
  - FFT—e.g., 64-point
  - Wavelet Transforms (segmentation)
  - Algorithms for
    - Flat
    - Impulsive (“spike”) noise
    - White noise
  - Other (ANN, etc.)

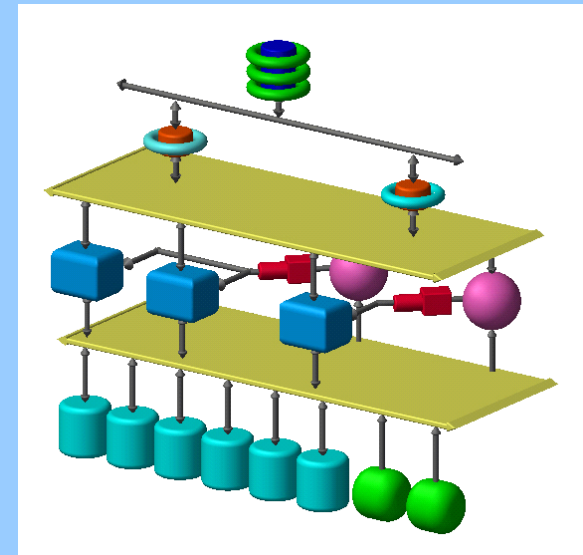

***Intelligent Sensors*** have embedded ISHM functionality and support ***Smart Sensor*** standards

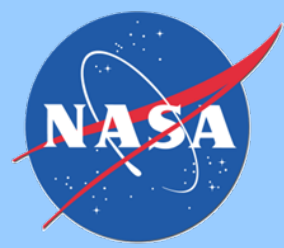

# Classic architecture describing how systems are built

