

December 1970

Brief 70-10443

NASA TECH BRIEF



NASA Tech Briefs announce new technology derived from the U.S. space program. They are issued to encourage commercial application. Tech Briefs are available on a subscription basis from the National Technical Information Service, Springfield, Virginia 22151. Requests for individual copies or questions relating to the Tech Brief program may be directed to the Technology Utilization Division, NASA, Code UT, Washington, D.C. 20546.

Circularly Polarized Antenna With Wide Projection and Range: A Concept

The slotted antenna structure shown in the figure radiates a circularly polarized beam pattern over a wide angle. The basic structure, composed of waveguide slots, can be flush mounted in an airplane or

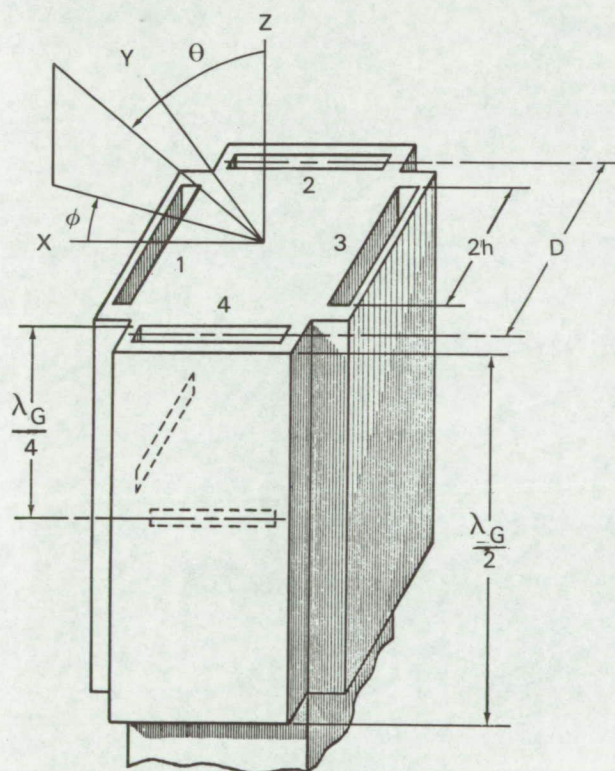

spacecraft, and could be used in the communication link between an airplane and an air traffic satellite.

Conventional antenna-element patterns of simple, linearly polarized antennas (slots and dipoles) differ in the two principal planes. A combination of two such

antennas can be chosen to make the array patterns nearly similar in the two planes. To achieve similarity, the first set of antennas is combined with the second set positioned orthogonal to the first. By driving the second set in phase quadrature with the first, a nearly circularly polarized beam is projected over a wide sector. This technique has an advantage over a crossed-slots design in that it can be used for antennas that are much more nearly circularly polarized over a wide angle, and that have an effective beam-width section which can be varied over a fairly wide range by simple changes in design.

Four slot-antennas (or dipoles) are oriented in the x-y plane, and are excited in pairs for broadside radiation (1 and 3 are in phase with each other, as are 2 and 4). The second pair (2 and 4) is driven in phase quadrature with the first (1 and 3), producing a circularly polarized beam at broadside. The field pattern in the plane on the axis of either pair of antennas (x-z plane for pair 1 and 3) is determined by the element pattern of the slot (dipole) in that plane, and hence by the electric field (current) on the slot or dipole. This field pattern is zero at $y = 0$. The field pattern of the same pair in the plane normal to the antenna axis (y-z plane) is determined entirely by the array factor of the two antennas, the distribution of which can be modified considerably by varying the distance D. Thus, the field pattern in this plane can be made similar to that in the x-z plane over a wide range of angles near broadside. When this is done for both sets of antennas, and when the antennas are excited in phase quadrature, the circularly polarized region extends over this same wide range of angles in the x-z and y-z planes.

The slot height, $2h$ (see fig.), may exceed the distance

(continued overleaf)

D, in which case the slots cross and must be supported by a dielectric frame.

Notes:

1. This development is in the conceptual stage only; at the time of this publication no model or prototype has been constructed.
2. Requests for further information may be directed to:

Technology Utilization Officer
Headquarters
National Aeronautics
and Space Administration
Washington, D.C. 20546
Reference: TSP70-10443

Patent status:

This invention is owned by NASA, and a patent application has been filed. Royalty-free, nonexclusive licenses for its commercial use will be granted by NASA. Inquiries concerning license rights should be made to:

Patent Counsel
Mail Code 200-11A
Ames Research Center
Moffett Field, California 94035

Source: L. C. Van Atta and R. J. Mailloux
Electronics Research Center
(ERC-10214)