

NASA Space Grant – Internship Final Report

Parachute Compartment Drop Test Vehicle for Testing the Crew Exploration Vehicle's Parachute Assembly System

Daniel P. Lubey¹, Sarah R. Thiele², Madelyn L. Gruseck³, and Carol T. Evans⁴
NASA Johnson Space Center, Houston, TX, 77058

Though getting astronauts safely into orbit and beyond has long been one of NASA's chief goals, their safe return has always been equally as important. The Crew Exploration Vehicle's (CEV) Parachute Assembly System (CPAS) is designed to safely return astronauts to Earth on the next-generation manned spacecraft Orion. As one means for validating this system's requirements and testing its functionality, a test article known as the Parachute Compartment Drop Test Vehicle (PC-DTV) will carry a fully-loaded yet truncated CPAS Parachute Compartment (PC) in a series of drop tests. Two aerodynamic profiles for the PC-DTV currently exist, though both share the same interior structure, and both have an Orion-representative weight of 20,800 lbf. Two extraction methods have been developed as well. The first (Cradle Monorail System 2 – CMS2) uses a sliding rail technique to release the PC-DTV midair, and the second (Modified DTV Sled; MDS) features a much less constrained separation method though slightly more complex. The decision as to which aerodynamic profile and extraction method to use is still not finalized. Additional CFD and stress analysis must be undertaken in order to determine the more desirable options, though at present the “boat tail” profile and the CMS2 extraction method seem to be the favored options in their respective categories. Fabrication of the PC-DTV and the selected extraction sled is set to begin in early October 2010 with an anticipated first drop test in mid-March 2011.

Nomenclature

<i>CEV</i>	=	Crew Exploration Vehicle (a.k.a. Orion)
<i>CFD</i>	=	Computational Fluid Dynamics
<i>CG</i>	=	Center of Gravity
<i>CMS2</i>	=	Cradle Monorail System 2
<i>CP</i>	=	Center of Pressure
<i>CPAS</i>	=	CEV Parachute Assembly System
<i>DTV</i>	=	Drop Test Vehicle
<i>GSE</i>	=	Ground Support Equipment
<i>MDS</i>	=	Modified DTV Sled
<i>OML</i>	=	Outer Mold Line
<i>PC</i>	=	Parachute Compartment
<i>PC-DTV</i>	=	Parachute Compartment Drop Test Vehicle

I. Introduction

Originally proposed in 2005, NASA's Constellation program planned to send manned missions back to the moon, to the completed International Space Station, possibly to a near-Earth asteroid, and finally to Mars within a matter of three to four decades. In recent months, though, the goals of this program have been put into

¹ Space Grant Intern, Systems Architecture and Integration Office (EA3), Johnson Space Center, The Pennsylvania State University

² Texas Aerospace Scholars Intern, Systems Architecture and Integration Office (EA3), Johnson Space Center, Texas A&M University

³ NASA JSC Co-op, Systems Architecture and Integration Office (EA3), Johnson Space Center, The Ohio State University

⁴ CPAS Deputy Project Manager, Systems Architecture and Integration Office (EA3), Johnson Space Center

question. Whatever the fate of Project Constellation, it seems that the manned capsule attributed to this program, Orion (a.k.a Crew Exploration Vehicle; CEV), will be utilized in some fashion whether it be as a lifeboat on the ISS or a crew transport vehicle for interplanetary missions. Designed in the likeness of the Apollo crew capsule, Orion is designed for a water landing under a cluster of parachutes that belong to a system termed the CEV Parachute Assembly System (CPAS). Currently approaching an August 2010 Preliminary Design Review (PDR), CPAS is at a point in its design lifecycle where system functionality and requirements validation testing have already commenced.

In order to validate several requirements related to parachute deployment, a Drop Test Vehicle (DTV) with a fully loaded, yet slightly truncated, CPAS Parachute Compartment (PC) has been designed for a series of drops from a C-130A aircraft at 25,000 ft (MSL). As a vehicle meant for airdrops, a method for extracting this DTV from its aircraft is also of primary importance. Two methods are described in this paper: a rail-based system known as the Cradle Monorail System 2 (CMS2), and a shear pin and saddle configuration known as the Modified DTV Sled (MDS). This DTV, named the Parachute Compartment Drop Test Vehicle (PC-DTV), takes the shape of a nose-heavy “dart” in order to assure free-fall stability, which in this case means that its nose continually points at the ground (nadir direction). During descent, a series of pilot, drogue, and main parachutes are deployed with the number of each depending on the specific test’s objectives.

II. Discussion

Presented in this section are design specifics relating to the PC-DTV and both extraction sleds. Topics addressed include: overview of critical design requirements, PC-DTV Outer Mold Line (OML) options, Computational Fluid Dynamics (CFD) inputs, overview of the PC-DTV design, PC-DTV avionics, the CMS2 design, the MDS design, and anticipated extreme load cases. Emphasis will be placed on the PC-DTV and MDS, as the first author was mostly involved with the design of these two vehicles. The details of the truncated PC design are not provided in this paper, as another team was responsible for its design. Specifics relating to fasteners, welds, and dimensions that are not provided within this paper can be found by obtaining the engineering drawings for these vehicles from NASA’s Engineering Design Control Center (EDCC) or directly from the CPAS team.

A. Overview of Requirements

In order to properly fit into an aircraft, be able to be extracted midair, and perform as a representative CPAS vehicle during descent, the design of the PC-DTV and its extraction sled was limited by several requirements. These requirements deal chiefly with the vehicles’ weights, dimensions, and aerodynamic performance. The most critical requirements are discussed in the following paragraphs.

In terms of weight, extraction out of a C-130A limits the weight of the integrated vehicle (PC-DTV, PC, sled, and all attachments) to between 30,000 lbf – 35,000 lbf. In this upper weight range special flight patterns must be designed, so it is best to stick to 30,000 lbf or less from a test operations standpoint. Additionally, in order to subject the parachutes to a representative Orion forebody, the PC-DTV when integrated with the PC is to weigh 20,800 lbf. This leaves the extraction sled to weigh between 9,200 lbf and 14,200 lbf, which is a range that agrees well with the weights of similar extraction platforms used in the past.

Restrictions on dimensions were driven primarily by aircraft requirements. When taking into account tipoff angles, margin for error, and aircraft interfaces the C-130A is limited to airdropping payloads with heights and widths not exceeding 100 inches and 108 inches, respectively. This height requirement contradicted the current dimensions of a full-sized CPAS PC, which meant a truncated PC would have to be designed if a C-130A aircraft was desired for drop test purposes. These truncations are discussed in section II.B.

The desire for the PC-DTV to perform predictably during descent set several additional vehicle requirements. First, to ensure aerodynamic stability it was required that during descent the PC-DTV’s central axis (through the nose) shall not deviate more than 20° from the nadir direction. This requirement more than any other drove the design of the PC-DTV to approach a “dart-like” shape. Second, in keeping with Orion’s requirements, the PC-DTV was required to not induce roll rates in excess of 120°/s.

Several requirements relating to scheduling also exist. The detailed design of the PC-DTV and its extraction sled is to be completed with engineering drawings by late-September 2010 in time for an early-October 2010 fabrication date. Fabrication of both vehicles (two copies of each) and all Ground Support Equipment (GSE) is to be completed by early-January 2011 with a targeted first drop test in mid-March 2011. Subsequent drop tests will follow throughout the course of the CPAS testing schedule.

In the end, these requirements are intended to define a vehicle that can be extracted from a C130A aircraft, represent Orion from a weight standpoint, and descend predictably through both the free-fall and parachute phases

of flight. Many other requirements exist regarding strength, test operations, and similar topics, but together they address the need for a DTV that survives all load cases and can be assembled and moved at the testing site. These concerns are discussed in the subsequent sections.

B. PC-DTV Outer Mold Line

At the start of the design process, two Outer Mold Line (OML) options for the PC-DTV were presented based upon DTVs used in testing of similar parachute systems. Figure 1 shows the first option, termed the “boat tail” OML, in the CMS2 configuration, which includes the protruding rail. This option is based on a DTV successfully used over three decades ago while testing the Space Shuttle’s Solid Rocket Boosters’ (SRB) parachute recovery system^[1]. This OML offers a high Center of Pressure (CP) due to surface area concentrated in the upper flare section, and when this is combined with a low Center of Gravity (CG) due to nose ballasting it results in an aerodynamically stable DTV that continually points nadir during descent. Additionally, this OML configuration closely resembles a separate high-Mach DTV currently under development by the CPAS group. By using this “boat tail” OML for the PC-DTV, data can be obtained and used when it comes time to test the high-mach DTV, which is a strong motivation to choose this OML option. This OML does have one major drawback, though. When in the CMS2 configuration the protruding rail lays exposed to passing air, which compromises the vehicle’s stability during descent and ruins the aerodynamic similarity with the high-Mach DTV. Several consequences relating to aerodynamic stability must be investigated if this OML and extraction method is ultimately chosen. These include: the rail acting as a fin and inducing roll rates in excess of stated requirements, the rail inducing high pitch angles that lead to aerodynamic stall, and the cylindrical components of the rail structure shedding vortices during descent.

Figure 2 details the second OML option known as the “snow cone” OML (pictured in the CMS2 configuration). This design more closely mirrors DTVs used during testing of Apollo’s crew module parachute system. Unlike the “boat tail” configuration, the “snow cone” does not expose much of its rail to passing air when in the CMS2 configuration. Unfortunately, it also has a lower CP and cannot easily be made to fit the Coleman extraction sled (if at all).

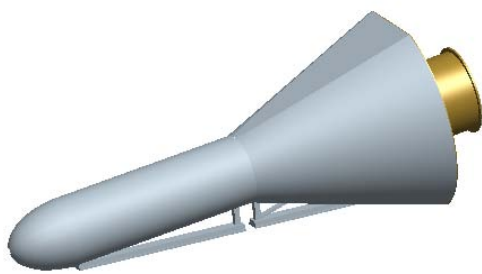

Figure 1. PC-DTV boat tail OML option in CMS2 configuration.



Figure 2. PC-DTV snow cone OML option in CMS2 configuration.

Both options would have relatively identical interior structures, and paneling on top of this structure would be used to create the desired OML. With such similar structures, each case would have virtually identical ballasting, which would mean that the CG position does not change from option to option. This means that the decision on which OML to use must be made on the basis of location of the CP, aerodynamic stability, compatibility with the chosen extraction method, and similarity with the high-Mach DTV.

As shown in figures 1 and 2, both of the conic portions of these OML options are slightly truncated. These truncations to the PC and the DTV were made in order to accommodate aircraft height restrictions as detailed in section II.A. Figure 3 shows the details of the truncated PC. These truncations reduce the height of the PC from 105.75 inches to 94.0 inches with unequal cuts across the single pilot parachute bay and a drogue containing bay opposite the former one. Several other truncations are also displayed, and these are detailed in section II.F. These truncations (along with the rail in the CMS2 configuration) no longer make these shapes axisymmetric, so sideslip angles become more significant

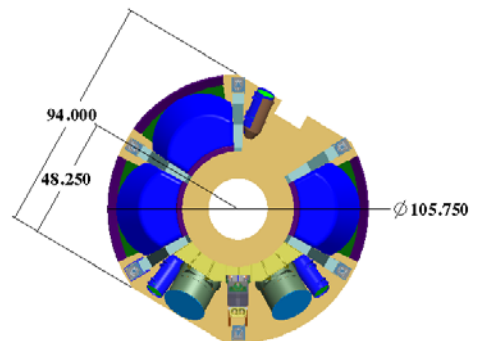

Figure 3. Truncations to PC in order to reduce vehicle height. Dimensions given in inches.

when running Computational Fluid Dynamics (CFD) simulations.

C. CFD Inputs

Based on prior drop tests, a set of environmental parameters that the PC-DTV will likely face during testing was assigned. These include the extremes of the freestream density, temperature, and Mach number during flight. Also provided is the set of orientation angles (angle of attack and sideslip angle) that was used to test the performance of these OMLs in the given environment. Table 1 details each of these parameters.

Table 1. CFD Analysis Inputs for PC-DTV

Parameter	Value	Dimensions
Freestream Temperature (T)	-25 to -5	°F
Freestream Density (ρ)	500	g/m^3
Freestream Mach Number (M)	0.25	-
Angle of Attack (α)	-20 to +20, ± 45 , ± 90	Degrees
Sideslip Angle (β)	-10 to +10	Degrees

The given temperature range comes from expected temperature extremes for a year-round DTV that is tested at 25,000 ft (MSL). In this temperature range the freestream density does not change appreciably so the lone value provided is sufficient - especially since at the given Mach number compressibility is not a factor. The angle of attack range stems from the requirement that the PC-DTV's nose does not deviate further than 20° from nadir. The additional angles are meant to test the PC-DTV's stability in extreme conditions. The sideslip angles are provided because the vehicle is not axisymmetric, especially with the protruding rail present, thus pitch and yaw become independent parameters.

Though results from this CFD analysis have yet to be reported, we expect that the boat tail OML will have a CP slightly more aft of the PC-DTV's nose when compared to the snow cone. This is because the former option has a greater concentration of surface area toward the PC, which makes for a higher CP. As the angle of attack increases this assumption loses validity, though. Stall concerns grow at large pitch angles, especially for an unstreamlined body such as the PC-DTV. It is recommended that the OML shape not be decided on until all CFD results are in, though the boat tail does seem to be the favored option at this point.

D. Overview of PC-DTV Design

Figure 4 shows the current design of the PC-DTV with the protruding CMS2 rail and no external paneling. It consists of three sections (named in order from nose to rear): the ballast section, the flare section, and the PC. From the tip of the nose to the back of the PC the PC-DTV measures approximately 22 feet long. The CG of the structure is approximately 125 inches aft of the nose (approximately one foot in front of the ballast-flare interface). All materials should be assumed to be ASTM A572 steel unless specified otherwise. This design has been termed the modular design because the sections can easily be taken out and replaced with others if needed. Subsequent descriptions and dimensions relate to the PC-DTV designed to fit the CMS2. Major modifications to the PC-DTV to have it fit in the MDS are detailed in section II.I. Likewise, there are slight differences between the snow cone and boat tail configurations. The details provided describe the boat tail configuration with some special mention of the snow cone configuration provided throughout.

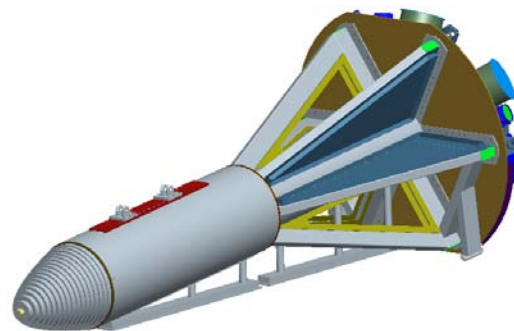

Figure 4. Current PC-DTV design without skin panels in CMS2 configuration.

E. DTV Ballast Section Design

Proper ballasting is a key factor in determining the aerodynamic stability of any dart-like projectile. In order to ensure that the nose of the PC-DTV does not deviate appreciably from the nadir direction during descent it is important that the CP remains aft of the CG by approximately one vehicle diameter for all angles of attack and

sideslip angles within operational conditions. With the PC located at the top of the PC-DTV and weighing approximately 5500 lbf (over a quarter of the entire vehicle weight), ballasting is critical to ensuring this vehicle’s stability.

Figure 5 shows the ballast used in the current dart model. It consists of a series of seventeen, 2.0 inch thick nose cone plates; a cap that is bolted to the ballast section’s body tube; a series of six, 2.0 inch thick, 550 lbf plates that reside within the ballast section body tube; and a 2.0 inch diameter Acme threaded rod that secures the ballast with a nut on either side. The nose cone plates vary in diameter such that when placed in the proper order they exhibit a parabolic outline. The stepped nature of these plates is anything but aerodynamic, but this method has been employed successfully with similar DTVs dropped at similar Mach numbers. The parabolic outline is not intended to help aerodynamically; rather, it allows more weight to be focused toward the nose, which helps to counteract the PC weight at the top of the dart. Behind these nose cone plates sits the ballast section’s body tube cap. This 4 inch thick plate bolts into the body tube and separates the exterior and interior ballast plates from one another while strengthening the body tube. Behind this cap sits the interior ballast plates. The current design has six of these plates, but this number can be increased or decreased based on weight and CG location requirements. Each of these plates is fashioned out of ASTM A572 steel such that altogether the ballast weighs 9,370 lbf. Steel, though not the highest density material available, was chosen for ballasting the PC-DTV because it was found that the price and availability of tungsten and the health hazards associated with lead made both of these materials (though denser than steel) unsuitable for ballasting. Other heavy metals exhibit the same price, availability, and safety concerns.

Other than ballast plates, the ballast section of the PC-DTV features several components including: a large diameter (36 inch) body tube to allow for large ballast weight to be concentrated toward the nose, a dual clevis attachment welded to the side of the body tube that is to be used for lifting purposes, a welded flange that allows for the ballast and flare sections to be fastened together, and an extraction sled integration feature that depends upon which extraction method is chosen. For a CMS2 configuration a protruding rail is welded to the side of this section’s body tube. For the MDS configuration a hole for a shear pin and a reinforcement within the body tube are present. The MDS configuration of this ballast section with the flare interface is displayed in Figure 6.

F. DTV Flare Section Design

The flare section of the PC-DTV serves as the interface with the PC, the location of the avionics trays, and in the boat tail configuration it is the paneled area. The design is a modified version of CPAS’s Parachute Test Vehicle 2 (PTV2), an Orion-OML representative drop test article. All components are made of steel except for the panels, which are made of 0.188 inch thick 6061 Aluminum. In total this section weighs 3,250 lbf with boat tail paneling.

Figure 7 shows most of the components of this section with the paneling removed. Essentially all of the components are welded to a central 24 inch diameter, 3/8 inch thick tube. Welded to one end of this tube is a welding neck flange that connects this 24 inch diameter

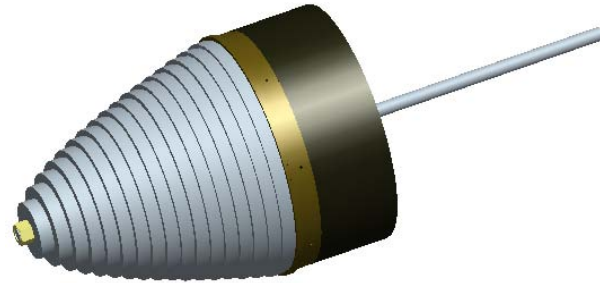

Figure 5. Ballast plates and locking mechanism used in the current PC-DTV design.

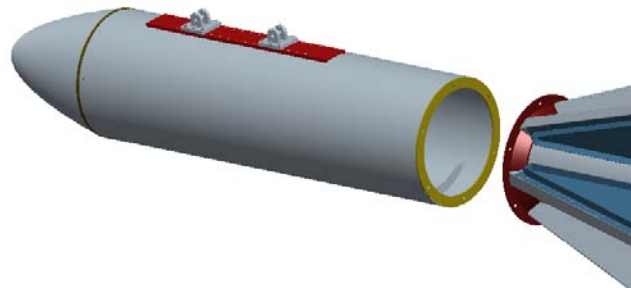

Figure 6. Exploded view of MDS configuration PC-DTV, with a focus on the ballast section and the flare-ballast flange interface.

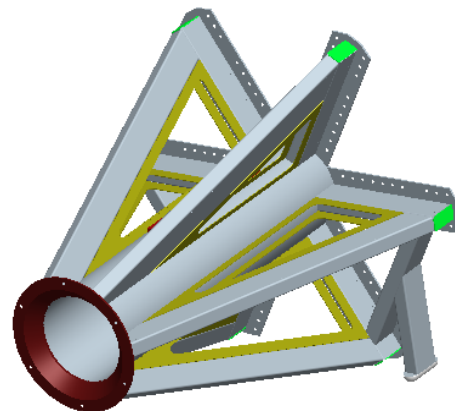

Figure 7. PC-DTV flare section without paneling or avionics trays.

tube to the ballast section’s 36 inch diameter tube. At the other end of this central tube are six rectangular tubes, rotated 60° from one another, that extend out perpendicular to the central tube’s axis. Atop these are plates that are matched drilled to interface with the truncated PC. Angled supports with a profile matching the boat tail panels (a 20° half-cone angle) are welded underneath the perpendicular, rectangular tubing; and they are further welded to the welding neck flange and bottom of the central tube. These supports effectively transfer the main loads to the central tubes in the ballast and flare sections, which are intended to be the main load-bearing structures. These supports also offer an interface for the panels. In the boat tail configuration the panels bolt directly into them, and in the snow cone configuration additional ribbing is required to match the profile.

Additional features in this section include: a dual clevis attachment used to lift this section, trays meant to store avionics, several gussets, and a rail in the CMS2 configuration. The clevis attachment is exactly the same as the one used on the ballast section except the welding plate was slightly modified to fit a different diameter tube. The avionics trays were designed to fit snugly in the triangular areas formed by the angled support beams. This current design encompasses two trays, but more or less may be used as the amount of avionics needed to achieve test objectives changes. Several gussets are also present throughout the structure. They are mostly included throughout the primary load paths as a means for strengthening areas that were identified as needing such during preliminary stress analysis. The design of the flare section’s rail is identical to that of the ballast sections. Shown in Fig. 8, the rail is comprised of a weld plate (similar to the lifting lug’s design) that attaches to three, 3.0 inch diameter tubes. The “shoe” at the bottom is comprised of a U-channel with several supporting inserts that are welded to a bottom plate.

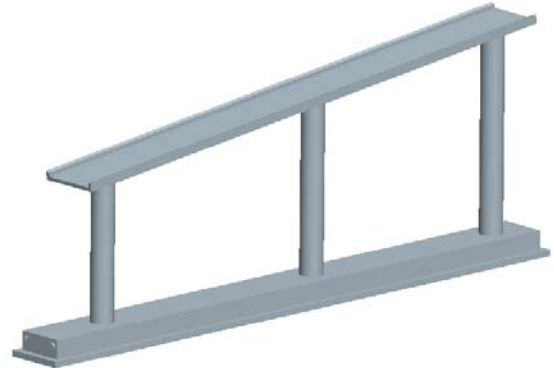

Figure 8. PC-DTV rail for CMS2 configuration.

G. DTV Avionics

As mentioned in the previous section, the avionics trays, shown in Fig. 9, on the PC-DTV are stored on the angled supporting arms within the flare section. The avionics used from test to test will change as the test objectives change, but in general they will always include: Inertial Measurement Units (IMUs), GPSs, accelerometers, timer boxes, air data probes, load cells, and associated batteries.

Outside of the avionics trays, several avionics are secured onboard the PC-DTV. Cameras intended to capture parachute deployment, reefing, and steady-state performance are aimed at the PC and above. These are located within the central tube of the flare section, and another proposed one would sit at the top of the flare section outside of the panels. An air data probe also is included in the ballast section of the PC-DTV. For the Coleman extraction technique, this probe would be located at the end of a long rod (6-7 feet long) that attaches to the nose of the PC-DTV. This long rod is needed to ensure that atmospheric data is not compromised by the presence of the PC-DTV. For the CMS configuration this data probe cannot be used because it would contact the extraction sled due to its angled orientation. Instead, a calibrated data probe, such as one used on commercial aircrafts will be attached to the side of the dart and take atmospheric readings.

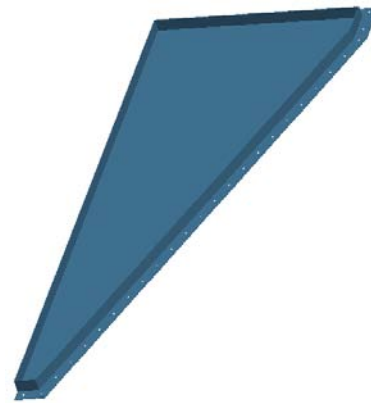

Figure 9. PC-DTV avionics tray.

H. CMS2 Design

The CMS2 design is based on drop tests previously run by the CPAS team. Figure 10 shows the current design of the CMS2, and Fig. 11 shows how the PC-DTV integrates with it. Essentially, it comprises a 24 foot rail guide system down the center of a 28 foot type V platform, which fits with the protruding rail on the PC-DTV. Behind this rail is a backstop, which serves as a four-point parachute attachment after extraction. Behind the backstop are the avionics and parachutes. The avionics generally change from test to test, but (generally) the parachutes include an extraction parachute that takes the vehicle out of the aircraft and 3 G-11 parachutes that the CMS2 lands under.

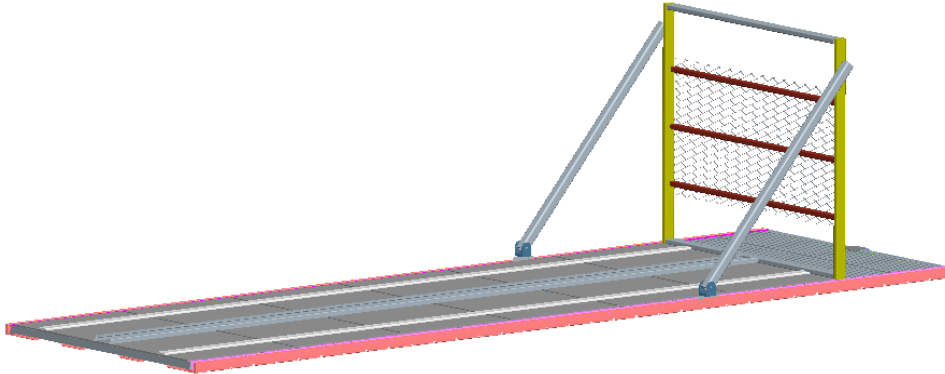

Figure 10. Current CMS2 design.

Though this extraction method has been used many times with great success, some concerns have risen based on qualities specific to the PC-DTV tests. First, generally the CMS2 is actually separated from the type V platform by several inches of honeycomb cardboard, but because of height restrictions this is not the case with the CMS2 – only a 0.5 inch aluminum plate separates the CMS2 and its platform. The additional truncation shown on the PC in Fig. 3 results from this height restriction. It is a 12 inch wide by 6 inch deep cut that accommodates the CMS2’s rail so that the PC-DTV can be placed as close to the platform as possible. Because of its segmented nature, the type V platform is rather flexible, which could cause problems when a rail guide is affixed to it. Specifically, the rail interface may bind after extraction, which would prevent the CMS2 and the PC-DTV from separating and achieving the stated test objectives. Another concern is that the rail interface will not be able to handle lateral aircraft and ground operations loadings. Typically, the rail interface between the test vehicle and a CMS does not require the test vehicle to be angled on the platform, but because of the large PC on the PC-DTV this is not the case. This angled orientation requires a protruding rail design, which is a concern from a lateral loading standpoint. The skids on the flare section of the PC-DTV were designed to assuage this problem, but further stress analysis must be completed to determine how effective they are. Finally, another structural concern is the CMS2’s side rails. Typically, they extend the full length of the CMS2 in order to better absorb the backstop’s parachute loading, but because of the width of the PC on the PC-DTV this is not possible. Reinforced gussets were added behind the CMS2’s backstop to resolve this issue, but more stress analysis must be performed to determine their effectiveness.

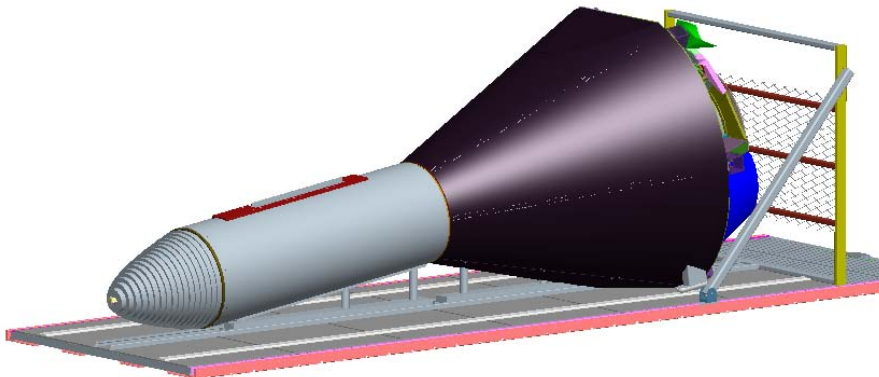

Figure 11. PC-DTV integrated with the CMS2.

I. MDS Design

The MDS design is based on drop tests of the Ares parachute recovery system. This method requires using a boat tail shaped DTV and no rail interface is used. As detailed in Figs. 12 and 13, this extraction platform consists of a saddle fixture that seats the ballast section of the PC-DTV while several Kevlar blankets wrap around and secure the dart with a winching system. Additionally, a shear pin interface sits just behind the saddle and prevents the PC-DTV from moving forward, aft, right, and left while in the aircraft. Upon extraction the platform pitches down, pyrotechnics release the blankets, and parachutes routed underneath the platform pull the shear pin out of the PC-

DTV. This option does have much more complexity in terms of test operations, simulations, and avionics but it does not involve any of the aerodynamic or structural complexities attributed to the rail design.

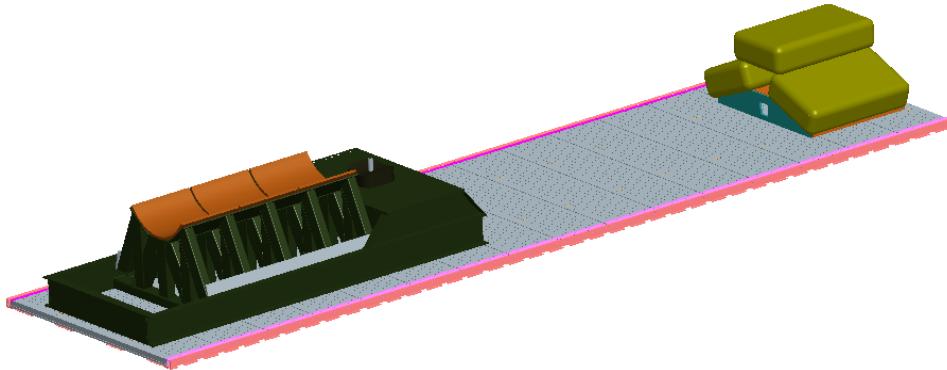

Figure 12. Current MDS design.

The actual hardware sitting on the 32' type V platform was reverse-engineered to fit the PC-DTV based on photographs and video taken of the Ares drop test. The sled's weldment is primarily composed of ASTM A572 members. It consists of several U-channels that measure 12 inches high and 0.5 inches thick. These form a perimeter that is 70 inches wide by 165 inches long. The saddle exists within this structure. It consists of five lateral beams with a truss design welded to each (Fig. 9), two longitudinal beams that connect the five sections, three plates that run the length of the five sections, and atop these plates are several cushions that allow the PC-DTV to sit comfortably. Connected to this saddle is a plate on either side where the blanket winching devices (not pictured) attach to the structure. The final piece of this structure is the shear pin interface and it sits just behind the saddle fixture. This portion of the structure consists of a corrugated steel box seated on top of several U-channels and bolted to two of perimeter beams. Atop this box are the pin's base and the actual pin.

All other structure on the extraction platform is either avionics or parachute related. Pictured at the rear of the sled are three parachute bags on a stand. Each of these bags contains a G-11 parachute, which will deploy to land the platform with its nose striking the ground at a rate not exceeding 33 ft/s.

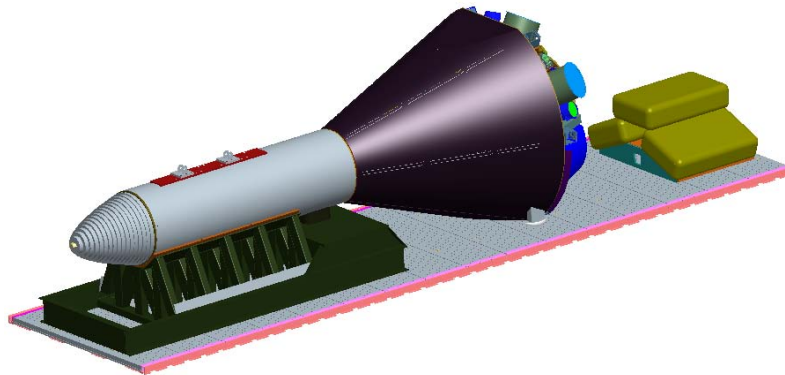

Figure 13. PC-DTV integrated with the MDS.

J. Load Cases

The PC-DTV and its extraction sled have several extreme load cases that must be tested through stress analysis to make sure that these articles can be airdropped. Though this is not flight hardware (and certainly not human rated), it is important from both safety and fiscal points of view to make sure that these vehicles do not fail structurally on the ground or in the air.

As a DTV meant to test parachute performance, the extreme load cases attributed to the PC-DTV are related to parachute snatch and inflation forces. For the CPAS system, this means that the most extreme load case occurs when the clustered mains inflate. This event routes a 100,000 lb force to the PC-DTV at an maximum shear angle of 20° (meaning the force is angled by as much as 20° from the PC-DTV's central axis). Other cases involving

programmer, pilot, and drogue deployment also produce sizeable loads, but if the PC-DTV can withstand the clustered mains deployment and inflation it is assumed to be structurally sound for all parachute related load cases.

Other than parachute-related load cases, the PC-DTV will experience extreme loads in several other situations. First, based on prior testing it assumed that at landing the PC-DTV could experience as high as a 50g shock event. It is assumed that an acceptable amount of damage will result from this event (primarily in the way of damaged skin panels), but there are also concerns related to the safety of the avionics and the vulnerability of the protruding rail upon landing. A second load case stems from aircraft loadings. While in a C-130A aircraft, one can expect maximum accelerations as outlined in Table 2. The chief concern regarding aircraft loadings is the lateral accelerations. In the CMS2 configuration, it is thought that these lateral loadings might put large moments on the rail and rail guide, which could lead to a failure scenario, so this will be a focus of early stress analysis. The PC-DTV and its extraction sled will experience similar loadings during ground operations, but with more safety harnesses applied to the vehicles the effects of the loadings should be drastically lessened.

Table 2. C-130A Aircraft Loading Environment

Axis	Direction	Max Acceleration
+x	Toward Nose	2 g
-x	Away from Nose	3.5 g
±y	Sideways	3 g
±z	Vertical	3 g

Like the PC-DTV, the extraction sled’s greatest load cases are due to landing and parachute events. In terms of parachute inflation, the greatest loads occur when the three G-11 recovery parachutes inflate. For the CMS2 option this load is localized to the four-point attachment on the backstop, and for the MDS option the loads are directed to the four parachute attachments that have yet to have their position determined precisely. Landing for the extraction sled will be much less severe than for PC-DTV. The sled will land at a maximum descent rate of 33 ft/s. The concern during landing is limiting damage to any avionics, and ensuring that the sled lands right side up. The MDS landing is less constrained than the CMS2’s, so it may land upside down. This will have to be kept in mind while determining avionics placement. As stated, it must be demonstrated that CMS2’s rail guide can withstand aircraft lateral loadings. For the MDS it is important to assure that the shear pin interface can withstand lateral and longitudinal loadings.

III. Conclusion

The PC-DTV and its extraction sled’s designs are still working models with an estimated mid-September 2010 design review and an early-October 2010 manufacturing date. Currently, two proposed OMLs and two extraction methods still exist. Decisions as to which shape to use will require CFD results, and the ultimate decision as to which extraction method is to be pursued will be informed by stress analysis and a trade study weighing the complexity and effectiveness of each method. Whichever method and shape is ultimately chosen, it has been shown that designs for a DTV and an extraction sled meeting the stated design requirements are feasible.

Looking to the immediate future, several things need to happen in order to make the early-October manufacturing date and, ultimately, the mid-March 2011 testing date. First, CFD results must be weighed versus items like structural complexity, similarity to the high-mach DTV, and test operations in order to determine which OML will ultimately be used. Without CFD results, the boat tail design is heavily favored over the snow cone, but with aerodynamic stability as a top-level requirement the CFD results will be a key factor in this design decision. Second, stress analysis regarding major load cases must be undertaken to ensure that these test vehicles are safe for drop testing and will be able to be used multiple times. Third, a trade study relating to the extraction method must be undertaken and completed, so that one of the two is decided upon. Currently, the CMS2 option seems to be favored, but with several structural and aerodynamic design concerns CFD and stress analysis results must be reported before this decision can be made. Finally, once the final detailed design of the PC-DTV and the extraction sled are completed, then engineering drawings must be prepared before manufacturing begins.

After these tasks are completed, manufacturing will commence and hopefully be completed in mid-January 2011. Drop tests are slated to begin in mid-March, and these test vehicles will continue to be used throughout the CPAS testing schedule. In a big-picture view, these tests will ultimately help CPAS validate its requirements and prove its functionality. Both of these types of tests are required for Orion to inevitably achieve a human rating,

which will inevitably lead to its use as a lifeboat for the ISS or possibly a home for astronauts exploring beyond Earth's orbit.

Acknowledgments

The first author would like to thank his mentor Carol Evans; his intern program coordinator Madonna Adams; and Sarah Thiele, Madelyn Gruseck, Robert Blaine, Randy Morris, and Ann Bufkin with whom he primarily worked on these designs with. He would like to thank Bruce Sauser, Jan Yokley, Stephen Porter, and Chris Johnson for their administrative support. He would also like to thank the many others who helped in the design of these three vehicles including (but not limited to): Hai Nguyen, Richard Hagen, Mark Landeck, Dave Young, Jeff Templeman, Aaron Morris, Eric Ray, Phil Stuart, Koki Machin, Robert Rimes, Roy Fox, Tim Fisher, and the entire CPAS team. He would especially like to thank Veronica Seyl and The Pennsylvania Space Grant Consortium, who made it possible for him to return to JSC for this internship.

References

¹Runkle, R. E., and Drobnik, R.F., "Space Shuttle Solid Rocket Booster Decelerator Subsystem – Air Drop Test Vehicle/B-52 Design,," AIAA 466-932, 1979.