

## **Electrostatic Power Generation from Negatively Charged, Simulated Lunar Regolith**

*Sang H. Choi<sup>1</sup>, Glen C. King<sup>1</sup>, Hyun-Jung Kim<sup>2</sup>, and Yeonjoon Park<sup>2</sup>*

*<sup>1</sup>NASA Langley Research Center  
Hampton, VA 23681-2199*

*<sup>2</sup>National Institute of Aerospace  
Hampton, VA 23666*

### **Abstract**

Research was conducted to develop an electrostatic power generator for future lunar missions that facilitate the utilization of lunar resources. The lunar surface is known to be negatively charged from the constant bombardment of electrons and protons from the solar wind. The resulting negative electrostatic charge on the dust particles, in the lunar vacuum, causes them to repel each other minimizing the potential. The result is a layer of suspended dust about one meter above the lunar surface. This phenomenon was observed by both Clementine and Surveyor spacecrafts. During the Apollo 17 lunar landing, the charged dust was a major hindrance, as it was attracted to the astronauts' spacesuits, equipment, and the lunar buggies. The dust accumulated on the spacesuits caused reduced visibility for the astronauts, and was unavoidably transported inside the spacecraft where it caused breathing irritation [1]. In the lunar vacuum, the maximum charge on the particles can be extremely high. An article in the journal "Nature", titled "Moon too static for astronauts?" (Feb 2, 2007) estimates that the lunar surface is charged with up to several thousand volts [2].

The electrostatic power generator was devised to alleviate the hazardous effects of negatively charged lunar soil by neutralizing the charged particles through capacitive coupling and thereby simultaneously harnessing power through electric charging [3]. The amount of power generated or collected is dependent on the areal coverage of the device and hovering speed over the lunar soil surface. A thin-film array of capacitors can be continuously charged and sequentially discharged using a time-differentiated trigger discharge process to produce a pulse train of discharge for DC mode output. By controlling the pulse interval, the DC mode power can be modulated for powering devices and equipment. In conjunction with a power storage system, the electrostatic power generator can be a power source for a lunar rover or other systems. The negatively charged lunar soil would also be neutralized mitigating some of the adverse effects resulting from lunar dust.

### **Fundamental Issues**

Over many millennia, the constant bombardment of meteoroids with the lunar surface has pulverized the regolith into fine particles. Combined with the lack of both a lunar atmosphere and a magnetic field, the result is negative charging of the fine dust by continuous bombardment of electrons and protons from solar winds. These negatively charged fine particles can be charged to a critical level up to several thousand volts of static electricity [2]. The electrostatically charged particles can cause arc damage and short-circuit electrical systems in

ungrounded equipment. Lunar exploration and resource exploitation missions may face potential disasters or be severely limited without a means to neutralize these charged particles. The concept being developed for this study could offer a solution to alleviate such problems by neutralization, while also harvesting electrical power. The power generated from negatively charged lunar soil may be sufficient to reduce or alleviate the power generated from other sources. This research demonstrates the feasibility of a system to neutralize the charged lunar soil and to collect the charge for generating electrical power required by lunar vehicles and equipment.

### Theoretical System Design for Power Collection

Two types of charge collection system were considered for this study as shown in Figures 1 and 5. A power generation system was built based on the collection and conversion of

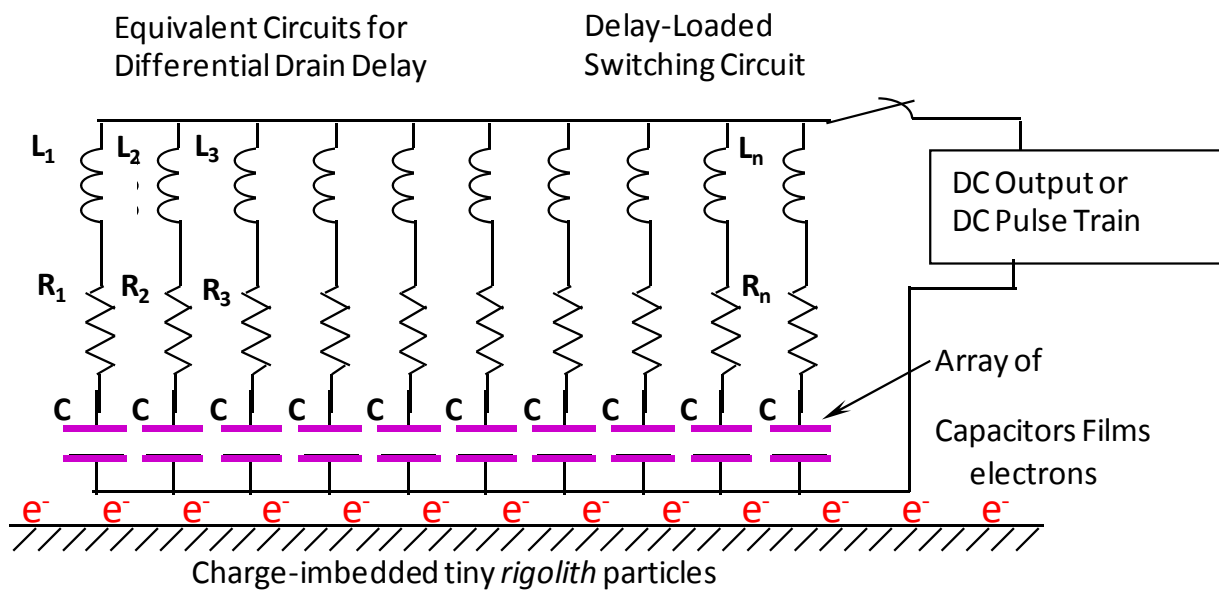

Figure 1. Equivalent circuit of power collection and conversion device from negatively charged Lunar soil.

capacitively charged electrons into modulated power as a useful power source (see Figure 1). The electrostatic power generator consisted of a vacuum chamber housing a tray of simulated lunar regolith. A motorized track assembly with an array of single-layered (flat) capacitors was secured above the surface of the regolith. The capacitors were customized for flexibility with a dielectric film sandwiched by thin-film metallic electrodes as shown in Figure 2. The dielectric film was selected from a material with a high dielectric constant and excellent flexibility. Figure 2 shows that the top and bottom electrodes sandwiching the dielectric film located in the middle. The capacitor strip shown in Figure 2 can be used for ten electron capture blades (see Figure

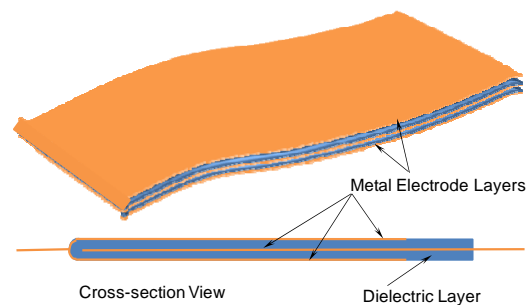

Figure 2. Electrodes and dielectric layers of a customized flexible capacitor strip.

3) that rake through the lunar soil. A flood beam electron gun was mounted at the top of the chamber to charge the regolith. Once charged, the capacitor array was dragged across the surface to collect and measure the charge. A video camera, laser and silicon photodetector were also placed within the chamber to observe and measure the extent of electrostatic levitation of the regolith particles. The capacitor array, was moved across the negatively charged lunar soil and becomes charged.

When the array of capacitors was fully charged, the electrons collected by each capacitor were released sequentially from one capacitor to another with a designated delay that was determined by circuit ( $L_i$ ,  $R_i$ , and  $C_i$ , where  $i = 1, \dots, n$ ) through a main bus of discharge switching device to a load. The delay in discharge process of each circuit is determined by the inductance ( $L$ ), resistance ( $R$ ), and capacitance ( $C$ ) of an LCR circuit. Figure 1 shows the equivalent circuit of the proposed capacitive charge collection and conversion device. The capacitive collector array that was designed to hold-off the breakdown voltage of several thousand volts has a parallel formation of capacitor strips in array. Each capacitor strip has its own discharge delay circuit which creates a pulse-width of discharged power with a predetermined delay. Thus, in an array discharge in sequence the final power mode is going to be a linearly coupled DC output. Such a sequence can be repeated cyclically to generate continuous wave of DC pulse train (see Figure 4). The delay time of circuit is determined by the combined effect of inductance,  $L$ , internal resistance,  $R$ , and capacitance,  $C$ , of each circuit as described in the following equation

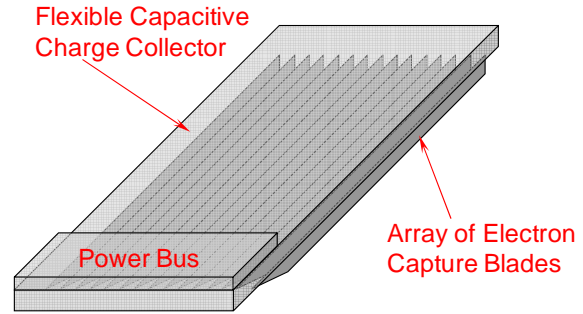

Figure 3. A single unit of charge collector that has an array of electron capture blades.

$$\begin{aligned}\tau_1 &= \sqrt{(R_1 + j\omega L_1)(G_1 + j\omega C_1)}, \\ \tau_2 &= \sqrt{(R_2 + j\omega L_2)(G_2 + j\omega C_2)}, \\ \tau_3 &= \sqrt{(R_3 + j\omega L_3)(G_3 + j\omega C_3)}, \\ &\cdot \\ &\cdot \\ &\cdot \\ \tau_n &= \sqrt{(R_n + j\omega L_n)(G_n + j\omega C_n)}\end{aligned}$$

where  $G_i$  is the conductance of the circuit which is normally negligible because of its minimal amount. The discharge sequence is dictated by the delay time of each circuit, such as  $\tau_1, \tau_1, \tau_1, \dots, \tau_n$ , as shown in Figure 4. The pulse modulation technology for the array of capacitive discharges is not new. Most electron accelerator laboratories use pulse modulation to provide modulated power to a Klystron for electron injection tube. Fine details of the modulated power output (i. e. dotted-line in Figure 4) can be made to be a flat DC output without fluctuation unlike the dotted line in Figure 4. The droop rate of modulated power (described by dotted-line in

Figure 4) can be smoothed out by tailoring LRC circuit parameters. As shown in Figure 1, the discharging circuit based on the LRC delay circuit parameters is operated by the single load switch. In such a case, the charge that is released at once with delay becomes a pulse train. If the total discharged power itself contained within a pulse train is not sequentially followed with an appropriate time gap, the output power, in general, becomes a pulse mode. To avoid the pulse mode output, a group formation of several arrays is regarded as a logical approach. Within a group, an array to array is triggered for discharge to the load with a time sequence to line up the pulse trains. These pulse trains lined up with a time sequence can sustain a continuous DC mode output.

Figure 5 shows another way to develop a modulated DC power using a programmable switching or load delay switch. Unlike the capacitive charge collector with differential drain shown in Figure 1, individual capacitive charge collector has its own load delay switch to discharge the load to the main bus. With the load delay switch, this system offers much more freedom for programmable operation of continuous wave (CW) DC power output. The switch will be selected by switching requirements such as switching voltage, current, and frequency. For low voltage and high frequency switching, semiconductor devices such as the IGBT or MOSFET can be used.

Since this system shown in Figure 5 is a loosely coupled system, any malfunction of a unit within an array would not cause any dip within DC power train. For example, if any one of the arrays goes bad, the programmable load delay switch adjusts the differential time gap among the active units to flatten the DC output. Nonetheless, both system designs described in Figures 1 and 5 are robust enough to perform the required power collection job.

The flexible capacitive collector is designed to freely run over any objects on the lunar surface and to hold off the charging voltage using a material with high dielectric constant.

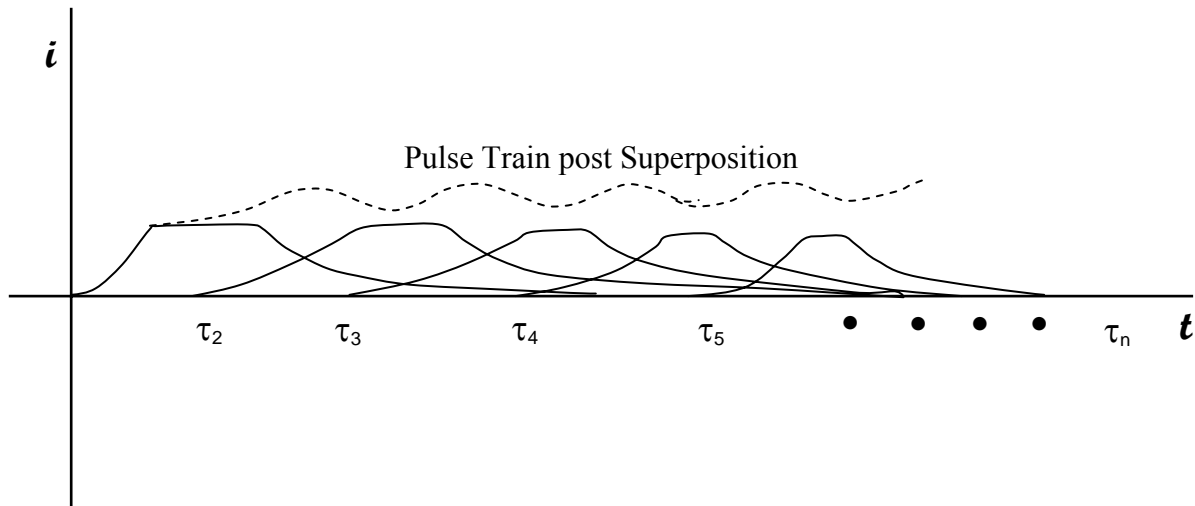

Figure 4. Example for pulse mode modulation of delay circuit.

Usually, the charged electrons of lunar soil generate several thousand volts of discharge [1]. Accordingly, the collector requires a high dielectric material sandwiched by metal layers to hold and sustain such a high voltage charge.

While the bottom metallic layer runs over and contacts the soil surface to collect electrons, the middle metallic layer of Figure 2 continuously develops an equal amount of opposite charges with a hold-off voltage. Each load delay switch has a role to monitor the charging process and detect the maximum charge level of capacitive collector until releasing collected electrons to the main power bus.

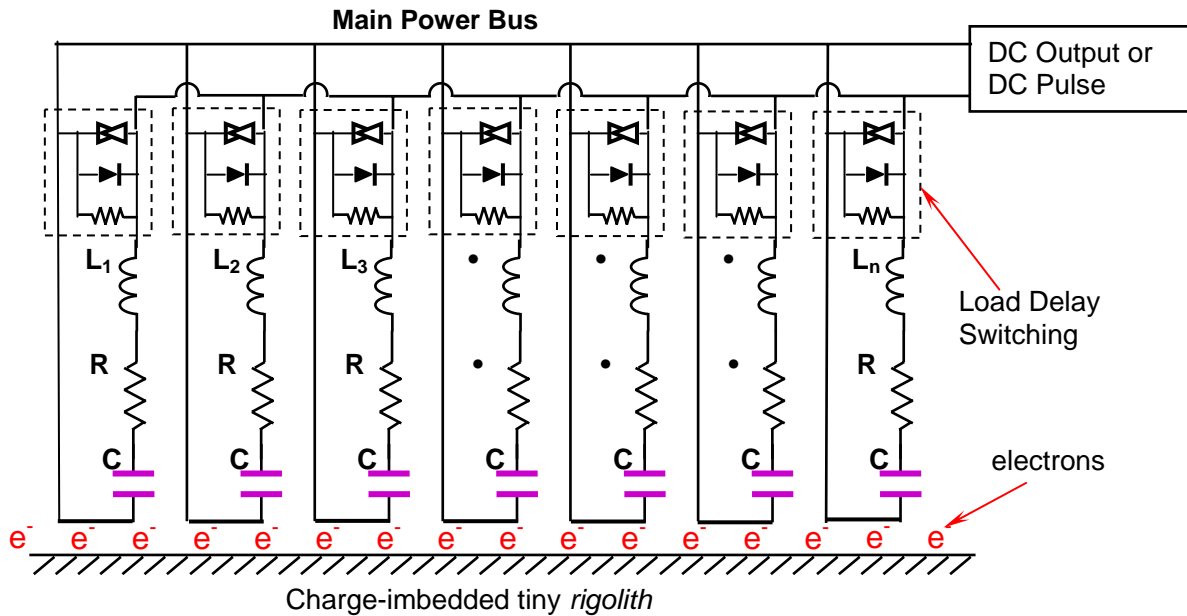

Figure 5. Equivalent Circuits for Differential Power Drain

**Collected Power Estimation** – There is not sufficient data available for charge density of lunar soil. Some reports mention several thousand volts of electrostatic charges on lunar soil [1, 2]. However, a simulation study done at NASA’s KSC reveals a 700 volt negatively charged condition of lunar soil [5]. The report by Timothy J. Stubbs et al. [6] discusses a triboelectric charge (or called “contact electricification” or “tribocharging” – transfer of charge from one body to another as they touch and come apart) that may acquire  $\sim 10^5$  electrons through inter-grain contact by an individual grain of lunar soil (diameter  $\approx 50 \mu\text{m}$ ). No other articles that report solar-electron charge were available [7]. Suppose that a grain has been charged over many millions of years to accumulate  $\sim 10^9$  electrons. The charge collector which has 10 blades as shown in Figure 3, that will move through the soil and thus interact with the charged grains of lunar soil. Consider that the size of blade is 5 cm high and 30 cm long x 2 sides. The total surface area of a blade is  $300 \text{ cm}^2$ . For 10 blades plus array base that holds 10 blades, the total area is  $3300 \text{ cm}^2$ . The maximum number of grains that will contact this open area of the charge collector would be  $132 \times 10^6$ . Therefore, the total maximum charge transfer at a given moment is  $132 \times 10^{15}$  electrons. If we consider the speed of charge collector motion would be 30 cm/sec. The maximum theoretical total charge per unit is  $21 \times 10^{-3} \text{ C/sec}$  (ampere). If we consider 10 units per array, the total maximum theoretical charge rate is  $21 \times 10^{-2} \text{ C/sec}$  or 210 mA or 0.21 A. Suppose that the open circuit voltage is 700 volts [5]. The total maximum theoretical power which can be harnessed from lunar soil is 147 Watts continuous per array. A rover that carries 40 array units might expect to collect 147 W/array.

## Experimental Procedure

Figure 6 shows the power generation system that was built to collect capacitively charged electrons and to convert them into modulated power. A vacuum of  $3 \times 10^{-5}$  torr was achieved using a molecular turbopump (Sargent Welch TurboTorr 3133) backed by a scroll roughing pump (Varian Triscroll 600). The chamber was purged six times with argon gas before the turbopump was activated. Once in the  $10^{-5}$  torr range, the flood beam electron gun was activated. The flood electron beam gun (Kimball Physics Inc. models EGF-6115 and EGPS-6115) for this system was used to electrostatically charge the fine particles of lunar soil simulant within the chamber. The electron gun was operated near the peak output of its capability. The beam voltage was set to 25kV, giving a beam current of 0.391 mA (and filament=1.348V/4.256A, 1<sup>st</sup> Anode=250V). The grid voltages of 0V and 100V were used to turn on and off (respectively) the electron beam. Using a PC Oscilloscope (Pico Technology, Ltd. PicoScope 4000 Series) the capacitor discharge voltages were recorded for charging times of 1, 5, 10, 22, 30, and 40 minutes.

The capacitance of the lunar regolith simulant was estimated by the LRC measurement system after sandwiching it between two aluminum foil plates and compressing the simulant to a 1.2 cm diameter disk shape using 15,000 pounds pressure. A Keithley LCZ Meter, model 3330, was used to measure a capacitance of about 110 pF/m.

The capacitor array used in the experiment is shown in Figure 7. After the simulant is charged by a flood e-beam flux, the e-beam gun is turned off for charge collection by a capacitor array. The capacitor array runs over the simulant surface to capture electrons charged on the particles of simulant. The charge collected by a capacitor array is then discharged through a dumping circuit installed outside the test chamber.

## Test Results

Two capacitor arrays were made for the charge collection test. The first one used in the test was made with a polyurethane film which has a static relative permittivity of 3. The measured capacitance of the first one was 200pF. With the e-beam voltage at 10 keV, the beam current was

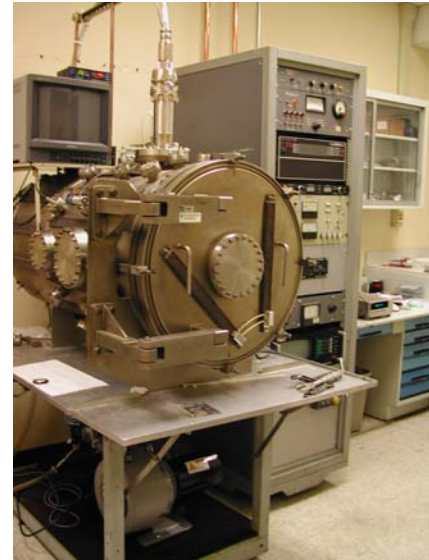

Figure 6. Experimental setup for electrostatic power generation from electro-statically charged lunar regolith simulant.

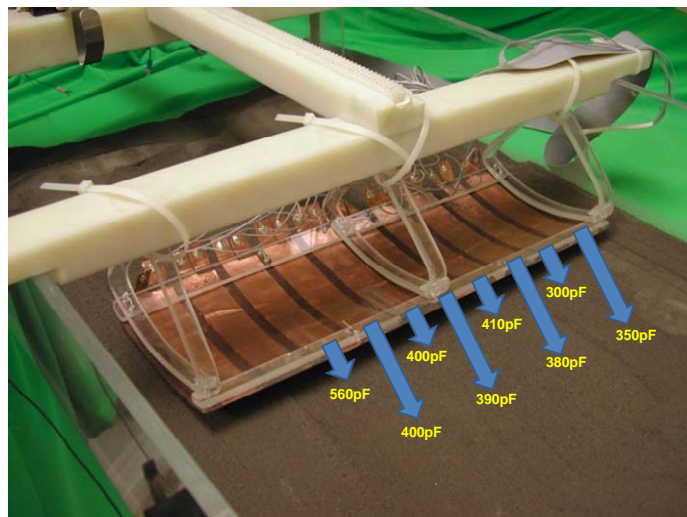
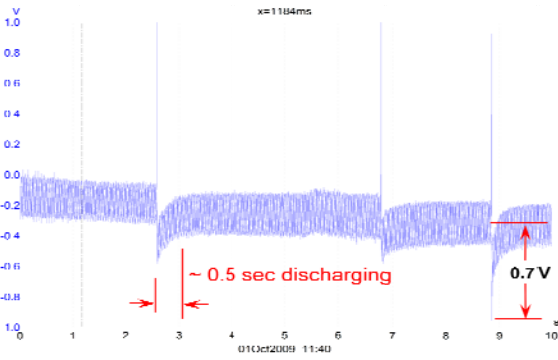
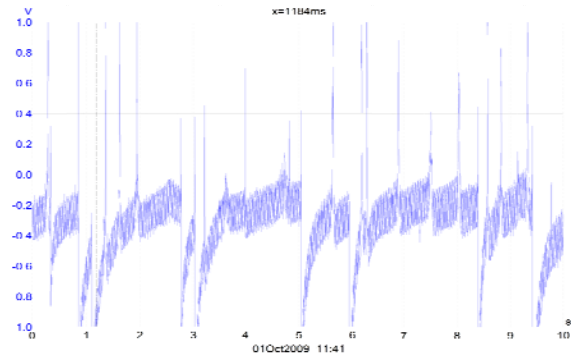

Figure 7. A home-made capacitor array was used for charge collection from simulant.



$I_{beam} = 5\mu A$ ,  $V_{beam} = 10keV$ ,  $I_{II} = 4.122A@1.35V$ ,  
Focus = 250V, 1st Anode = 250V, Grid = 0

Figure 8. The charge and discharge diagrams of 200pF capacitor array. The charging voltage is about 0.7 V but discharged over 0.5 second.



$I_{beam} = 15\mu A$ ,  $V_{beam} = 20keV$ ,  $I_{II} = 4.122A@1.35V$ ,  
Focus = 250V, 1st Anode = 250V, Grid = 0

Figure 9. The charge and discharge diagrams of 200pF capacitor array. The charging voltage is about 2.0 V but discharged over 0.6 second.

set at  $5\mu A$  for charging simulant particles. After the simulant was charged by a  $5\mu A$  beam current, the e-beam was turned off and a 200pF array ran over the simulant surface to collect the charges. The repeated cycles of charging and discharging are shown in Figure 8.

The results in Figure 9 were obtained with a 20-keV e-beam voltage by setting the beam current at  $15\mu A$  for charging simulant particles. After the simulant was charged by a  $15\mu A$  beam current, the e-beam was turned off and a 200pF array ran over the simulant surface to collect the charges. The repeated routines of charging and discharging are shown in Figure 9. In each case of Figures 8 and 9, the number of electrons collected by the capacitor array from the simulant were  $0.874 \times 10^9$  and  $2.5 \times 10^9$ , respectively.

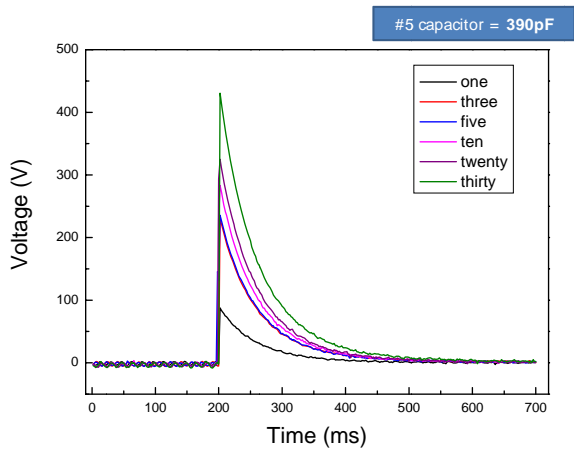

Figure 10. Charge collections by 390pF capacitor and gradual decays according to the exposure time of simulant to a 25kV and 0.391 mA e-beam flux.

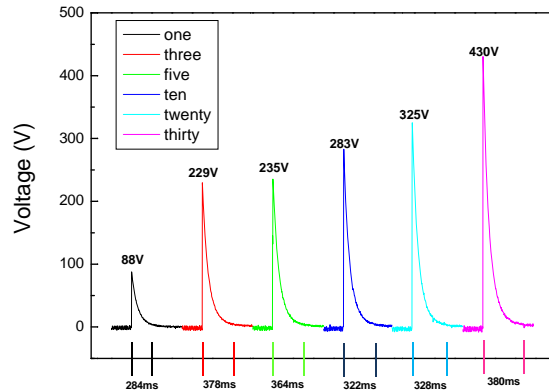

Figure 11. Charge collections and discharge decay diagrams of 390pF capacitor.

The second capacitor array was built with a Polyvinylidene Fluoride (PVDF) membrane having a relative static permittivity of 10 at room temperature under 1 kHz. One of the capacitors in the array (the 5th from the right in Figure 7) was only used for this experiment. This 5th capacitor has 390pF capacitance. The parameters selected for testing were the exposure

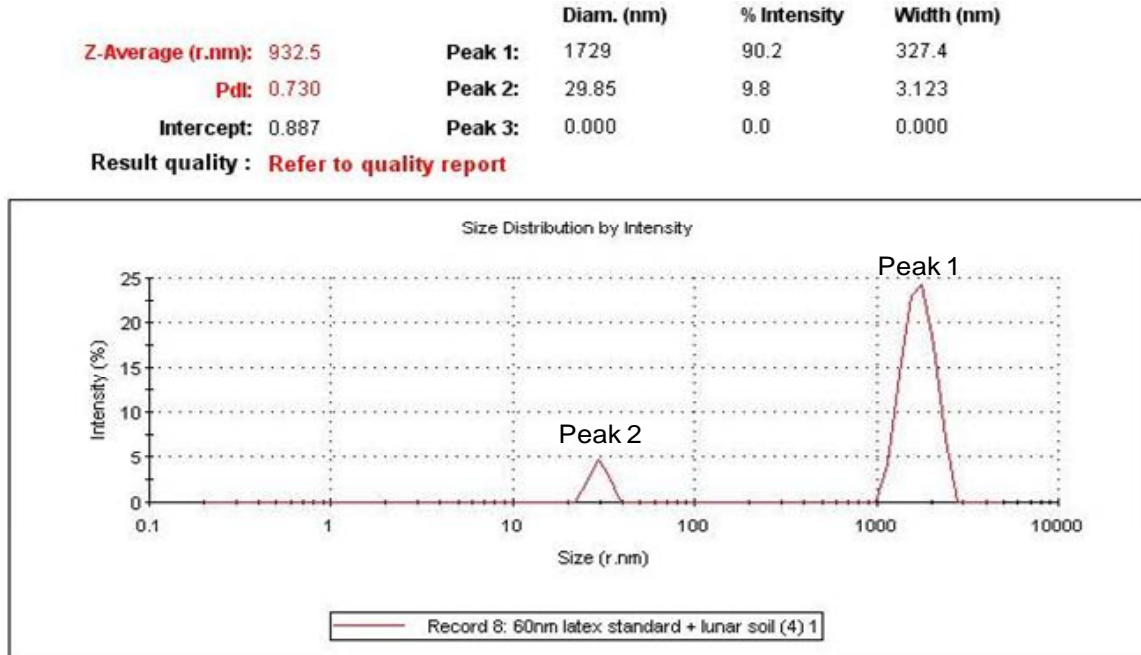

Figure 12. Particle size of regolith simulant used for experiment

time of simulant to e-beam flux of 25kV and 0.391 mA beam current. Figure 10 shows the charges collected by the 5th capacitor, from the charged simulant, that were exposed to the e-beam flux for 1, 3, 5, 10, 20, and 30 minutes, respectively. The voltage profiles after charging indicate that the collected charges gradually decay, through an external discharging mechanism, in approximately 400 ms. The x-axis of Figure 11 shows the discharge decay times of collected charges. The numbers of electrons collected according to the exposure times of simulant were  $2.14 \times 10^{11}$  for 1-minute,  $5.57 \times 10^{11}$  for 3-minutes,  $5.72 \times 10^{11}$  for 5-minutes,  $6.89 \times 10^{11}$  for 10-minutes,  $7.91 \times 10^{11}$  for 20-minutes, and  $1.05 \times 10^{12}$  for 30-minutes, respectively. The incremental trends of electron collection along with the exposure times from a constant e-beam flux are expected as shown in Figure 11. The regolith simulant particle sizes used in this experiment are shown in Figure 12 (the curve at 1000 nm). However, the camera and laser measurement system did not detect any levitating charged particles. Several reasons for this observation include the particle sizes and numbers that were not small and abundant enough to get particles levitated for detection, the lunar gravity is roughly 6 times less than the gravity of earth and the soil particles, although chemically similar to the lunar regolith, also may not have the same surface area or topology.

## Conclusions

The experiments performed to demonstrate the possibility of harvesting the electrostatic charge of lunar soil from solar wind by a moving capacitor array as a DC power were



successfully accomplished by using a lunar regolith simulant in the laboratory setup. The regolith simulant was charged by a flood stream of e-beam flux for a set period of time. The charge collection was proportional to the exposure period of simulant to e-beam flux. Such a process demonstrates a method for lunar power generation while simultaneously neutralizing the charged regolith simulant.

The tests performed to verify the levitation of charged fine particles of simulant were not successful due largely to the strong gravitational effect, unlike on the moon, and to the size of the particles prepared for experiment.

## References

- [1] Goodwin R., Apollo 17 NASA Mission Report, 2002.
- [2] Nature News, "Moon too static for astronauts?", 2 February, 2007.
- [3] Sang H. Choi, James R. Elliott, and Glen C. King, "Electrostatic Power Generator with Capacitive Charge Collectors," NASA Invention Disclosure Case No. LAR 17516-1, November 28, 2006. ID: 5022945.
- [4] Electrostatic Properties of Lunar Dust,  
<http://rtreport.ksc.nasa.gov/techreports/2001report/200/206.html>
- [5] Timothy J. Stubbs, Richard R. Vondrak, and William M. Farrell, "Impact of Dust on Lunar Exploration", Proc. 'Dust in Planetary Systems', Kauai, Hawaii, 26-30 Sept, 2005 (ESA SP-643, Jan. 2007).
- [6] Otis R. Walton, "Adhesion of Lunar Dust", NASA CR-2007-214685, April, 2007.