

NASA Tech Briefs

THE DIGEST OF NEW TECHNOLOGY

Official Publication of the
National Aeronautics and
Space Administration
August 1994 Vol. 18 No. 8

Transferring Engineering
Technology to Over 200,000
Qualified Readers Throughout
Industry and Government



**HOW NASA HELPED A
SILICON VALLEY START-UP
BECOME AN INDUSTRY GIANT**

Get Interactive!

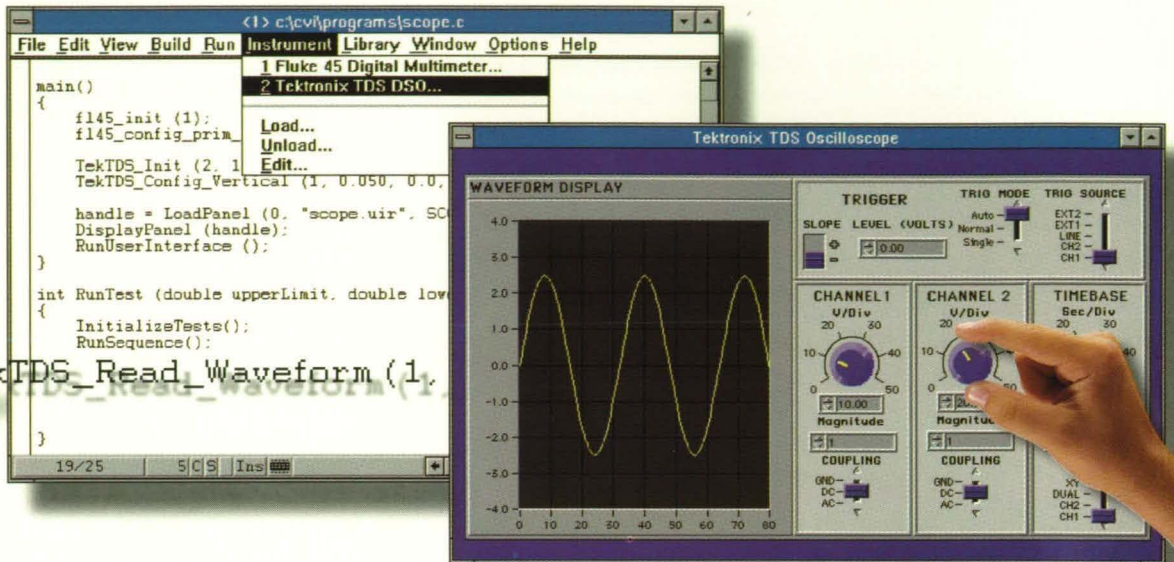

LabWindows®/CVI

The Programming Power of C, the Development Ease of BASIC

Discover a new approach to C programming for instrumentation – the interactive approach. With LabWindows/CVI, you harness the power and flexibility of ANSI C through easy-to-use interactive code-generation tools. LabWindows/CVI is an ANSI C programming environment with GUI objects, instrumentation libraries, data analysis functions, and utilities specifically designed for data acquisition and instrument control systems.

Interactive Development

As an instrumentation system developer, you need quick results. With LabWindows/CVI function panels, you can interactively acquire data from plug-in boards, or control GPIB, VXI, and RS-232 instruments without writing a single line of code. Then, use function panels to generate code automatically and jump start your programming efforts.

C Programming Flexibility

LabWindows/CVI is more than just interactive tools to make programming easier. With LabWindows/CVI, you have the power and flexibility of ANSI C at your fingertips, so you can be assured that it is fast enough, powerful enough, and flexible enough to get your job done. Plus, the integrated LabWindows/CVI environment has the advanced editing, compiling, and debugging tools you expect. Combining the power of ANSI C with an interactive, BASIC-like development environment results in true programming productivity.

You don't have to sacrifice ease of use when you program in a standard language anymore.



Call for a **FREE**
LabWindows/CVI
demo disk
(800) 433-3488
(U.S. and Canada)



6504 Bridge Point Parkway • Austin, TX 78730-5039 • Tel: (512) 794-0100 • 95 (800) 010 0793 (Mexico) • Fax: (512) 794-8411

Branch Offices: Australia 03 879 9422 • Austria 0662 435986 • Belgium 02 757 00 20 • Canada 519 622 9310 • Denmark 45 76 26 00 • Finland 90 527 2321 • France 1 48 14 24 24 • Germany 089 741 31 30
Italy 02 48301892 • Japan 03 3788 1921 • Netherlands 03480 33466 • Norway 32 848400 • Spain 91 640 0085 • Sweden 08 730 49 70 • Switzerland 056 27 00 20 • U.K. 0635 523545

© Copyright 1994 National Instruments Corporation. All rights reserved. Product and company names listed are trademarks or trade names of their respective companies.

For More Information Write In No. 636

See us at Sensors Expo, Booth 854

Within budget. Without compromise.

New real-time
vector display

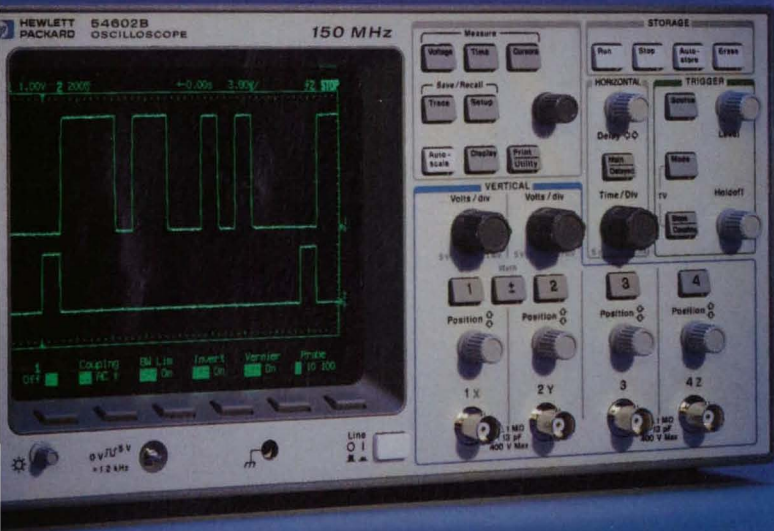

The value of this scope is easy to see.

Take a close look at the HP 54600-series oscilloscopes, and you can't help but notice certain things.

It looks and feels like an analog scope, with dedicated knobs and a display that responds instantly to your control changes. Yet it has all the digital power that analog can't give you—high accuracy, automatic measurements, hard copy output and programmability. And superior viewing of virtually any waveform, even at low rep rates and slow sweep speeds.

But what really stands out is that the HP 54600-series scopes give you all this performance at a great price: HP 54600B 100 MHz (2-channel) **\$2,495***. HP 54601B 100 MHz (4-channel) **\$2,995***. HP 54602B 150 MHz (4-channel) **\$3,395***. HP 54610B 500 MHz (2-channel) **\$4,995***. And that's a value worth looking into.

☎ For more information, call HP DIRECT, 1-800-452-4844, Ext. 8507. We'll be happy to send you literature or let you talk to an HP engineer.

*U.S. list price

There is a better way.

 **HEWLETT®
PACKARD**

© 1994 Hewlett-Packard Co. TMPMO452/NTB



Does your checker make you ANSI?

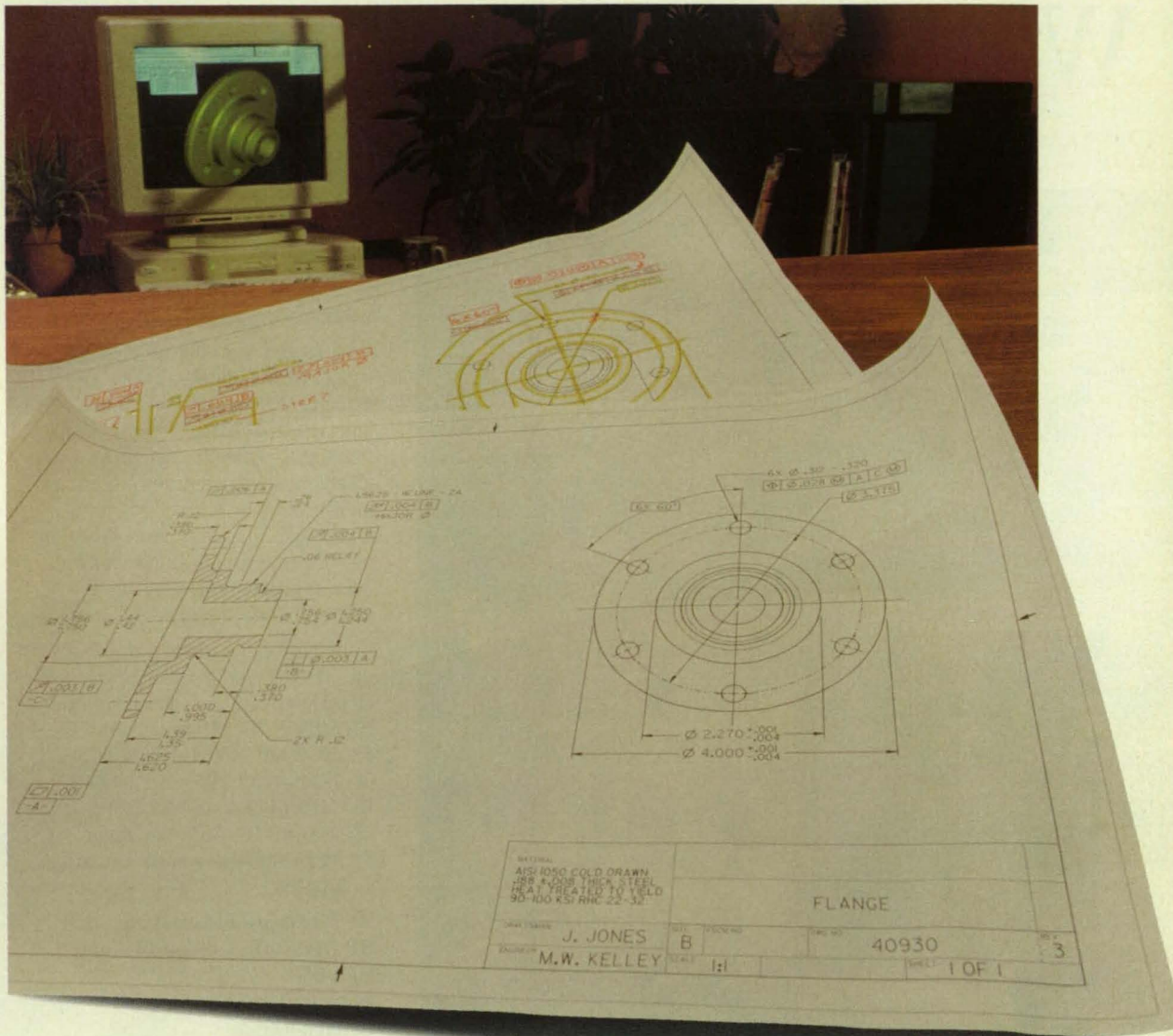

MicroStation and MicroDraftsman Engineered to meet the ANSI standard

For mechanical design and drafting, MicroStation and MicroDraftsman are the winning combination. Together, they help you increase productivity.

That's because MicroStation brings you the most powerful and flexible 2D/3D design tools on the market today. Tools that make creating mechanical designs a breeze.

And MicroDraftsman gives you quick, simple, accurate drafting and detailing tools that make documenting drawings to ANSI standards easy.

For more information on increasing your productivity with the MicroStation/MicroDraftsman combination, call 800-345-4856. And ask for your free demo disk.



INTERGRAPH

Solutions for the Technical Desktop

For More Information Write In No. 632

Intergraph and the Intergraph logo are registered trademarks and Solutions for the Technical Desktop and The Mechanical Desktop are trademarks of Intergraph Corporation. MicroStation and the MicroStation stylized M are registered trademarks of Bentley Systems Inc., an Intergraph affiliate. Other brands and product names are trademarks of their respective owners. © 1994 Intergraph Corporation, Huntsville, AL 35894-0001. DDAD175A0

When Time Is Money...



Rated #1 for . . .

- **Availability of Product!**
- **On-Time Delivery!**
- **Overall Performance!**

Call, write or fax for your
FREE CATALOG today!

Digi-Key[®]
CORPORATION

Quality Electronic Components, Superior Service

1-800-344-4539

701 Brooks Ave. South, Thief River Falls, MN 56701

Fax: 218-681-3380

For More Information Write In No. 609

Contents

NASATechBriefs

Transferring
Engineering Technology
to Over 200,000 Qualified Readers

FEATURES

12 NASA Patents

14 Mission Accomplished

TECHNICAL SECTION

18 Special Focus: Computer Hardware



- 18 Fast, Massively Parallel Data Processors
- 22 Redundant Buses for Loosely Coupled Dual Computers
- 22 High-Speed Optical Wide-Area Data-Communication Network
- 23 Crossbar Switches for Optical Data-Communication Networks

33 Electronic Components and Circuits



- 33 Multiconductor Short/Open Cable Tester
- 34 Capacitive Sensor With Driven Shields and Bridge Circuit
- 36 Low-Voltage Bypass Device
- 36 Inrush-Current Limiter and Bus Isolator
- 38 Reducing Ripple in a Switching Voltage Regulator
- 38 Modified Relay Switch Has Lower Resistance
- 39 Regulator Circuit for Bilateral Source/Load Power System

40 Electronic Systems



- 40 Dither Helps Compensate for Friction in Reaction Wheel
- 41 Dual Overlapping, Weighted Preaveragers
- 42 Robust Routing Protocol for Digital Messages
- 43 Estimating Antenna-Pointing Error Using a Focal-Plane Array
- 44 Improved Hidden-Markov-Model Method of Detecting Faults

46 Physical Sciences



- 46 Miniature Reversal Electron-Attachment Detector
- 47 Verification and Correction of X-Ray-Spectrometer Peak Positions and Intensities
- 48 Use of Video in Microscopic and Ultrasonic Inspection
- 49 Ultrasonic Inspection with Angular-Power-Spectrum Scanning
- 50 Estimating Elevation Angles From SAR Crosstalk
- 51 Dipsticks for Clear Liquids

52 Materials



- 52 Phonon-Scattering Centers Increase Thermoelectric Efficiency
- 52 Polyimides Containing Silver Trifluoroacetate
- 53 Deposition of Cubic BN on Diamond Interlayers
- 54 Iridium-Coated Rhenium Combustion Chamber
- 54 Depositing High-T_c Superconductors on Normal-Conductor Wires
- 55 Using Water To Analyze Greasy Residues
- 56 Generating High-Pressure Oxygen Electrolytically
- 57 Copper Alloy for High-Temperature Uses
- 58 Electrically Conductive Polyimide Films Containing Gold Surface
- 59 Melt-Infiltration Process For SiC Ceramics and Composites

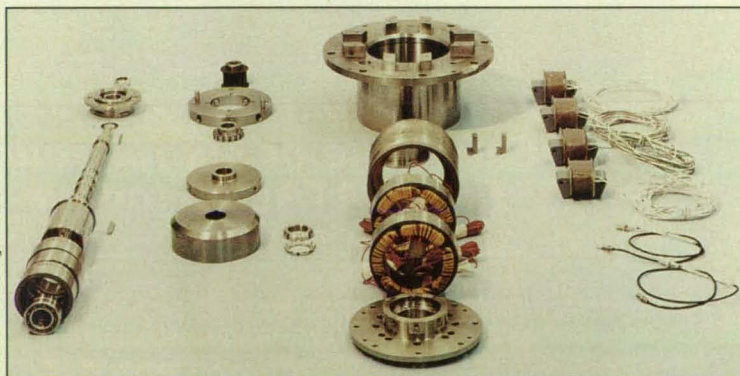

Photo courtesy Lewis Research Center

Scientists at Lewis Research Center have created bearings in which permanent magnets are employed to suspend shafts while electromagnets provide active control of the shafts' position. Operable in temperatures from -196°C to 343°C , these hybrid magnetic bearings are designed for use in rocket engine turbopumps where conditions severely limit lubrication of conventional ball bearings. For more information see the tech brief on page 66.

(continued on page 6)

At 200 MB Per Minute, We're Setting The Pace.



TRUE COMPATIBILITY WITH

Alliant	Macintosh
Alpha Micro	McDonnell Douglas
Altos	Motorola
Apollo	NCR
Arix	NeXT
AT&T	Novell
Basic-4	OS/2
Concurrent	PS/2
Convergent	Parallel Port
Data General	PC 386/ix
DEC SCSI	PC MS-DOS
DEC BI-Bus	PC Xenix/Unix
DEC DSSI	Pertec
DEC HSC	PICK
DEC Q-Bus	Plexus
DEC TU/TA81	Prime
DEC Unibus	Pyramid
Gould/Encore	Sequent
HP	Silicon Graphics
IBM AS/400	STC
IBM Mainframe	Stratus
IBM RISC/6000	Sun
IBM RT	Texas Instruments
IBM S/38	Unisys
ICL	Ultimate
Intergraph	Wang
	— and more

The CY-ASP is the fastest digital data storage solution on the market, able to store up to 70 GB at speeds of up to 200 MB per minute, unattended.

But there's more.

The fastest subsystem is also the most flexible, giving you a choice of four recording modes plus offline copy and verify functions.

In **Single Mode** the drives operate independently.

In **Cascade Mode** data automatically writes to the next tape once the previous tape is full.

In **Mirroring Mode** the same data writes to multiple tapes simultaneously.

In **Striping Mode** data writes to two or more tapes at once, maximizing throughput.

Consider it a data storage management tool, a solution that will help you solve the problems you encounter every day: the need for higher capacity and speed, the need to make duplicate tapes for off-site storage and data exchange, the need for real-time status information, and the need to save resources and boost productivity on every level.

Of course, we also know that a storage solution is only as good as the data you get back. With a bit error rate of less than 1 in 10^{17} bits read, the CY-ASP gives you the *highest* data integrity.

Based on proven 8mm helical scan technology, each drive supports our switch-selectable *data compression* option. And each drive features a 2-line, 40-column backlit display that gives complete status information.

Backed by a two year warranty that includes expert service and support from our in-house engineering group, the CY-ASP is setting the pace in performance, flexibility and value.

Other configurations are available, ranging from a 2.5 GB subsystem to an intelligent, automated 3 TB tape library. And they're all compatible with the widest range of computer systems and networks.

When you're ready for a data storage solution that means business, call for complete information.

(804) 873-9000

CONTEMPORARY
CYBERNETICS

Contents *(continued)*

60 Computer Programs

-  60 Estimating Delays in ASIC's
- 60 Event/Time/Availability/Reliability-Analysis Program
- 61 Weld-Fill Program
- 62 Program Generates Two-Dimensional Computational Grids
- 62 Program Helps Decompose Complex Design Systems
- 63 HYPERSAMP
- 63 Software for Analysis of SAR Data
- 64 Predicting Properties of Composite Materials

65 Mechanics

-  65 Adjustable Deflector for Ultrasonic C-Scan
- 66 Cryogenic Hybrid Magnetic Bearing
- 66 Safety-Valve Mechanism for Pressure-Vessel Window
- 67 Torsion and Bending Alleviator
- 68 Positioning Fixture for Survey Antenna
- 68 Self-Locking Spreading Pliers
- 69 Spring- and Air-Suspension Mechanism for Testing Structures
- 70 Ultrasonic Measurement of Elastic Constants of Composites

72 Machinery

-  72 Spatial-Operator Algebra for Flexible-Link Manipulators
- 72 Algorithm for Control of Underactuated Manipulators
- 73 Permanent-Magnet Meissner Bearing
- 74 Linear Electromagnetic Actuator With Manual Override
- 75 Self-Calibrating, Variable-Flow Pumping System
- 76 Hermetically Sealed Compressor

77 Fabrication Technology

-  77 System Grows Single-Crystal Fibers
- 78 Wire Stripper Holds Insulation Debris
- 78 Analysis and Control System for Automated Welding
- 79 Capacitive Measurement of Coating Thickness on Carbon Fibers
- 80 Resin-Powder Dispenser

DEPARTMENTS

Notebook	10
New Product Ideas.....	16
NASA Technology Transfer Services	20
New on the Market.....	92
New Literature.....	94
Advertisers Index	97

83 Mathematics and Information Sciences

-  83 Method of Predicting Size of Software Under Development

84 Life Sciences

-  84 Mathematical Modeling of Life-Support Systems

85 Books and Reports

- 85 Milliwatt Electric Power Sources Would Last for Years
- 85 Normalization of Thermal-Radiation Form-Factor Matrix
- 85 Fingerprinting of Materials
- 85 Recent Developments in Theory of Balanced Linear Systems
- 85 Magnetic Subassembly for Directional-Solidification Furnace

On the cover:

One of Silicon Graphics' first customers, NASA's Numerical Aeronautic Simulation (NAS) program pioneered application of the company's visual computing systems. Used by NAS to visualize complex computational fluid dynamics data sets, the machines now provide dynamic 3D graphics for applications ranging from automotive design to special effects animation. Here, an image generated using molecular simulation software from BIOSYM Technologies and running on a Silicon Graphics workstation models the bovine pancreatic trypsin inhibitor protein in crystal form. Turn to Mission Accomplished on page 14.

Photo courtesy BIOSYM Technologies Inc.

This document was prepared under the sponsorship of the National Aeronautics and Space Administration. Neither Associated Business Publications Co., Ltd. nor the United States Government nor any person acting on behalf of the United States Government assumes any liability resulting from the use of the information contained in this document, or warrants that such use will be free from privately owned rights. The U.S. Government does not endorse any commercial product, process, or activity identified in this publication.

Permissions: Authorization to photocopy items for internal or personal use, or the internal or personal use of specific clients, is granted by Associated Business Publications, provided that the flat fee of \$3.00 per copy be paid directly to the Copyright Clearance Center (21 Congress St., Salem, MA 01970). For those organizations that have been granted a photocopy license by CCC, a separate system of payment has been arranged. The fee code for users of the Transactional Reporting Service is: ISSN 0145-319X/94 \$3.00+ .00

NASA Tech Briefs, ISSN 0145-319X, USPS 750-070, copyright © 1994 in U.S. is published monthly by Associated Business Publications Co., Ltd., 41 E. 42nd St., New York, NY 10017-5391. The copyright information does not include the (U.S. rights to) individual tech briefs that are supplied by NASA. Editorial, sales, production, and circulation offices at 41 East 42nd Street, New York, NY 10017-5391. Subscription for non-qualified subscribers in the U.S., Panama Canal Zone, and Puerto Rico, \$75.00 for 1 year; \$125 for 2 years; \$200.00 for 3 years. Single copies \$10.00. Foreign subscriptions one-year U.S. Funds \$150.00. Permit by check, draft, postal, express orders or VISA, MasterCard, and American Express. Other remittances at sender's risk. Address all communications for subscriptions or circulation to NASA Tech Briefs, 41 East 42nd St., New York, NY 10017-5391. Second-class postage paid at New York, NY and additional mailing offices.

POSTMASTER: Please send address changes to NASA Tech Briefs, 41 E. 42nd Street, Suite 921, New York, NY 10017-5391.

Merlin™ Mesh Enhancement Technology gives you the highest quality finite element mesh available

Typical unconditioned meshes from "competitive" products

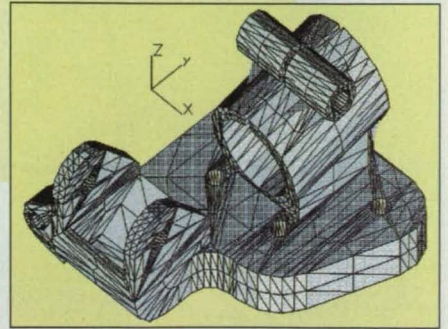
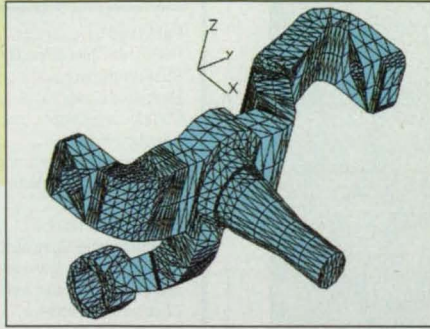
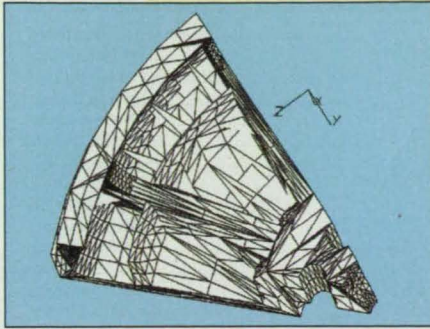

After Merlin™ one-step mesh enhancement technology

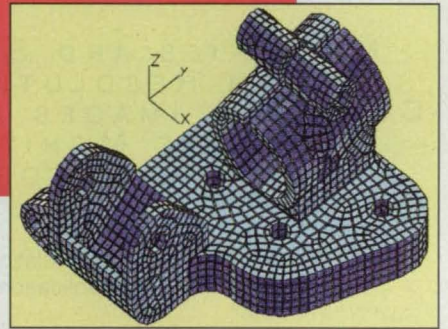
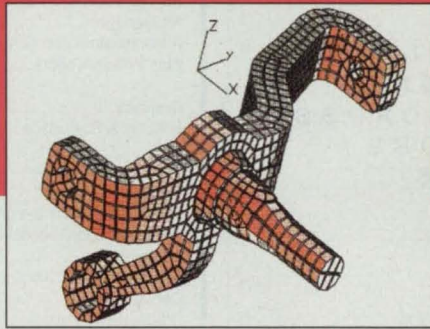
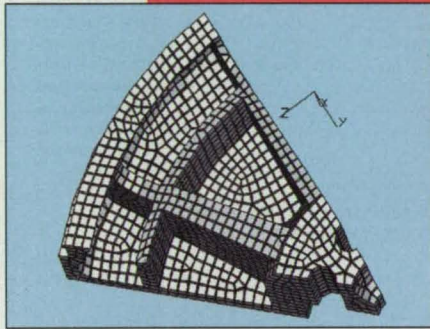

(Algor brick element models above shown with an 85% shrink-element factor.)

Merlin produces engineering-quality, quadrilateral surface meshes for high-accuracy plate/shell FEA or 8-node "brick" element generation using Hexagen (fully automatic). Merlin enhances the mesh quality of Algor's modeling and design software. In addition, Merlin is included in Houdini™ which is unique software that takes existing or new CAD solid models and automatically creates high-accuracy, 8-node "brick" finite element models.

Additional "After Merlin" Examples

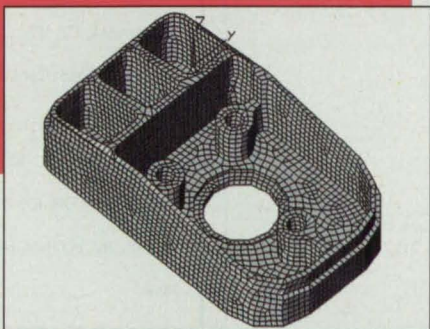
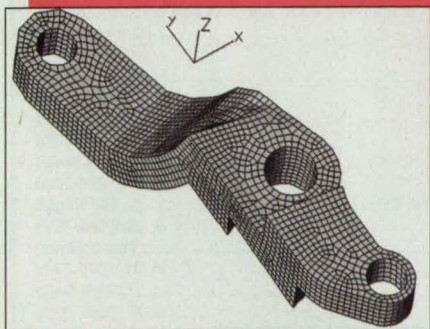
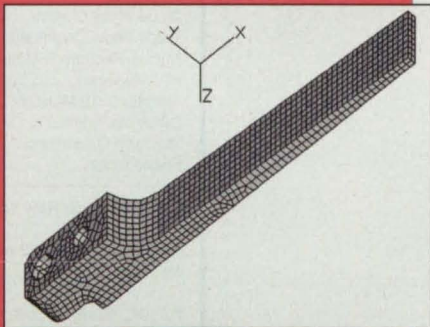
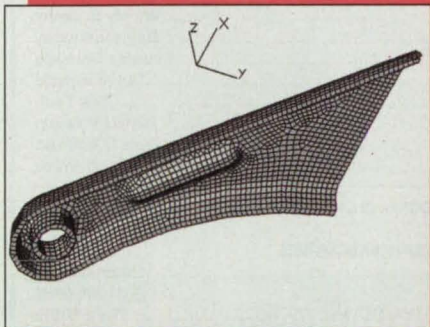

Merlin technology turns a 3- or 4-node surface mesh or CAD solid model into a high quality 4-node mesh in an easy, one-step process.

ALGOR®
When the Engineering
Has to be Right™

Algor backs its software products with a Satisfaction Guarantee. Call or write for details.

For DOS, UNIX and Windows NT

150 Beta Drive
Pittsburgh, PA 15238-2932 USA
Phone: (412) 967-2700
Fax: (412) 967-2781
California: (714) 564-2541
Europe (UK): +44 (784) 442 246
Tokyo: +81 03-3589-6148

™ Trademark of Algor, Inc.
Copyright © 1994 Algor, Inc.

For More Information Write In No. 518

COMPUTERWALL™



MAGNIFIES AND SPLITS
HIGH RESOLUTION
COMPUTER IMAGES ACROSS
MULTIPLE MONITORS
OR PROJECTORS

Control room, C², simulation
and multimedia applications

Automatically synchronizes
to raster-scan input signals
from 31.5-80 kHz

Inputs any workstation
or PC imagery up to
1280x1024 pixels

Displays text, graphics,
animation and full-motion
video

Full 24-bit color

Real-time operation

Compatible with all software

Functions perfectly under
high ambient light

Made in the USA



SPECTRUM®

950 Marina Village Parkway Alameda, CA 94501
Tel: (510) 814-7000 Fax: (510) 814-7026

NASA Tech Briefs

Official Publication of the
National Aeronautics and
Space Administration



NASA Tech Briefs

Published by.....	Associated Business Publications
President/Chief Executive Officer.....	Bill Schnirring
Publisher/Editor.....	Joseph T. Pramberger
Executive Editor.....	Sarah L. Gall
Contributing Editor.....	Robert Clark
Assistant Editor.....	Gregg McQueen
Director of Manufacturing.....	Gregg Weatherby
Advertising Coordinator.....	Margery Koen
Art Director.....	Pierre Granier
Marketing Director.....	Wayne Pierce
Telemarketing Specialist.....	Evelyn Mars
Reader Service Manager.....	Scott Floman
Assistant to Reader Service Manager.....	Damiana Garcia
Circulation Director.....	Martin J. Horan

BRIEFS & SUPPORTING LITERATURE: Written and produced for NASA by
Advanced Testing Technologies, Inc., Commack, NY 11725

Technical/Managing Editor.....	Ted Selinsky
Sr. Technical Analyst.....	Dr. Larry Grunberger
Art Manager.....	Eric Starstrom
Administrator/Chief Copy Editor.....	Greg Gallitzine
Staff Writers/Editors.....	Dr. Theron Cole, Dr. Claude Swanson, George Watson, Howard Falk
Graphics.....	Robert Simons
Editorial & Production.....	Deborah Satinsky, Brian Boicchio Teresa Johnson

NASA:

NASA Tech Briefs are provided by the National Aeronautics and Space Administration, Technology Transfer Division, Washington, DC:	
Administrator.....	Daniel S. Goldin
Deputy Assistant Administrator(Programs).....	Frank E. Penaranda
Deputy Director Technology Transfer Division (Publications Manager).....	Leonard A. Ault
Manager, Technology Transfer Office, NASA Center For AeroSpace Information.....	Walter M. Heiland

ASSOCIATED BUSINESS PUBLICATIONS

41 East 42nd Street, Suite 921, New York, NY 10017-5391
(212) 490-3999 FAX (212) 986-7864

President/Chief Executive Officer.....	Bill Schnirring
Executive Vice President/Chief Operating Officer.....	Domenic A. Mucchetti
Treasurer.....	Joseph T. Pramberger
Controller.....	Athena Thomas
Credit/Collection.....	Felecia Lahey
Staff Accountant.....	Larry Duze
Trade Show Director.....	Wendy S. Janiel
Trade Show Coordinator.....	Danielle Krasny
Human Resources Manager.....	Lourdes Del Valle
MIS Manager.....	Ted Morawski
Assistant MIS Manager.....	Pak Tong
Office Manager.....	Sylvia Valentin
Mailroom Operations.....	Thomas C. Snyder, Rose D'Addozio
Receptionist.....	Tracy A. Wenz

ADVERTISING: New York Office: (212) 490-3999 FAX (212) 986-7864

NASA TECH BRIEFS ACCOUNT EXECUTIVES

NY, NJ.....	Brian Clerkin at (201) 366-2751
PA, DE, NJ (Area Code 609), VA, DC, MD, WV, NC.....	Tara Morie at (215) 640-3118
Eastern MA, NH, ME, RI.....	Paul Gillespie at (508) 429-8907; Bill Doucette at (508) 429-9861
Western MA, CT, VT.....	George Watts at (802) 875-3310
Southeast, South Central.....	Douglas Shaller at (212) 490-3999
OH, MI, IN, KY.....	Scott Burrows at (216) 928-1888
IL, WI, MO, IA, MN, ND, SD, NE, KS.....	Melinda Mead at (312) 296-2040
N. Calif., WA, OR, ID, MT, WY, CO.....	Bill Hague at (206) 858-7575
S. Calif., AZ, NV, NM, UT.....	Tom Stillman at (310) 372-2744
Japan.....	Akio Saijo at 03 (3555) 0106

TURN ON

Eaton switches. Individually designed to perform critical functions in space, on earth and under the sea. So you'll find them in aircraft and submarines—and in between—on computers, power tools, industrial machines, ships, cars, trucks...

Because Eaton is one of the world's largest manufacturers of switches—for a world of applications, and the severe environmental challenges they bring.

That's one thing that sets Eaton apart. Using innovative solutions is another.

At Eaton, we're part of your team. Solving today's problems. Anticipating tomorrow's needs.

We do more than make parts.

We manufacture solutions.

EAT•N

For More Information Write In No. 643

NYSE: ETN





For many years we've wanted to have a regular "Letters to the Editor" column. We've also wanted to have a forum where our family of readers could share problems and suggested solutions to those problems. Our problem has been one of space in the magazine, since we want to publish as many tech briefs as possible as quickly as possible.

That's why we're instituting a bulletin board on CompuServe's "Ideas and Inventions" forum. We understand that this is only a partial solution, since not all of our readers have access to CompuServe, but it's a start.

To access the forum, all you have to do is type "Ideas" at the GO prompt on the CompuServe opening page and look for the *NASA Tech Briefs* Feedback Forum. We hope that the "family" of *NASA Tech Briefs* readers will see this as a tool both to communicate with the editors and to help each other with ideas, problems, and solutions to problems.

The forum will be open in Beta test form in August...we look forward to reading you there.

TECHNOLOGY 2004 & ABSENTEE BALLOTS

TECHNOLOGY 2004 will be held in Washington, DC this year on November 8-10 at the Washington convention center. Since this is the heart of our nation's government, we thought it appropriate to remind those of you who will be travelling to attend that the opening day of the show, Tuesday, is Election Day and that you might want to start thinking about getting your absentee ballots soon.

While we look forward to reading your thoughts on the bb, we're equally looking forward to seeing you all at TECHNOLOGY 2004, which we tend to think of as the annual gathering of the *NASA Tech Briefs* community of readers and contributors. See pages 25-32 for further details on TECHNOLOGY 2004 and National Technology Transfer Week. □

**Power.
When you
need it.
Whenever
you need it.**

The Evans Capattery. Very small, very powerful, very reliable.

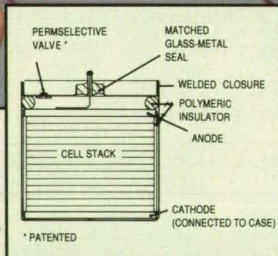

This incredible double-layer capacitor is a unique carbon-based device that is housed in a welded tantalum package.

Its patented Permelective valve allows it to release CO₂ generated during normal operation while inhibiting the escape of electrolyte vapors and preventing contaminants from entering the container.

A 5.5-volt, 1F Capattery has a volume of 0.5 in.³, an 11-volt, 0.5 F Capattery has a volume of less than 1 in.³.

The Capattery has a temperature range of -55°C to 85°C. It withstands unlimited charge/discharge cycles.

EVANS

P.O. Box 4158, East Providence RI 02914
(401) 434-5600. Fax (401) 434-6908.

NEW FROM ASTRO-MED!

**30 Channels!
Brilliant Monitor!
Huge Memory!
Laser Resolution Chart!**

TRUE FIELD RECORDER[®]

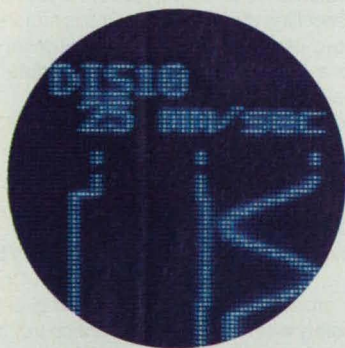

- Bright, High Response Monitor
- 10, 20 or 30 Waveform Channels
- Laser Quality (300 dpi) Chart Resolution
- Huge 512 KSample Memory per Channel for Data Capture and Analysis
- True Portability: Internal Battery and AC
- Record up to 500 V Peak (Isolated) at 25 kHz Response
- Analyze Data with FFT, etc.
- On-Board Floppy Drive for Setup and Memory Transfer
- Wide Format 11-Inch Chart

The all-new Dash 10 lets you receive up to 30 waveform channels (DC to 25 kHz), see the data in real time on the bright high-speed vacuum fluorescent monitor, record with laser quality fidelity, and *at the same time* capture the data for playback and analysis. Now you can do all this on a truly portable package powered by internal battery or AC. The Dash 10 comes with a powerful software package, has a floppy disk for updates and data archiving, plus RS-432, RS-232 and GPIB.

Phone, fax or write for details!

Astro-Med, Inc.

Astro-Med Industrial Park, West Warwick, Rhode Island 02893
Phone: (401) 828-4000 • Toll-Free (800) 343-4039 • Fax: (401) 822-2430
In Canada Telephone 1-800-565-2216

Sales and Service Centers throughout the U.S. and Canada

Astro-Med is system certified to ISO 9001

For More Information Write In No. 662

Free access to federally funded technology is a phone call away.

The National Technology Transfer Center (NTTC) puts the world of government research right on your desktop.

- **Free** Access to Federally Funded Technology
- Electronic Bulletin Board announcing technology transfer opportunities
- Training on Technology Transfer Issues
- Strategic Partnering Conferences

Why not call
800-678-6882
today and discover the
research opportunities
right at your fingertips.



National Technology Transfer Center
Wheeling Jesuit College
316 Washington Avenue
Wheeling, WV 26003 Fax: 304-243-2529

For More Information Write In No. 408

PATENTS

NASA

NASA has a portfolio of 3000 patents and pending applications available now for license by businesses and individuals, including these recently patented inventions:

High Temperature, Oxidation Resistant Noble Metal-Al Alloy Thermocouple

(US Patent No. 5,275,670)

Inventors: **James Smialek** and **Michael Gedwill**, Lewis Research Center

A novel thermocouple enables accurate measurement of high temperatures (600-1300 °C) in inert, oxidizing, or reducing environments, gases, or vacuum. The device comprises an electropositive leg formed of a noble metal-Al alloy—where the noble metal is platinum, iridium, palladium, silver, or gold—electrically joined to an electronegative leg. It eliminates the need for expensive, strategic precious metals such as rhodium.

For More Information Write In No. 730

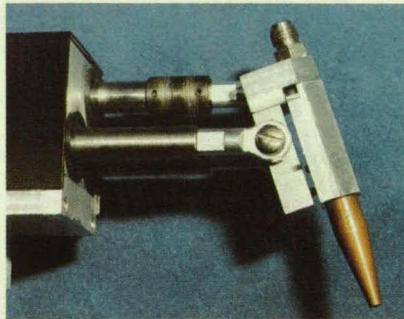

Welding Wire Pressure Sensor Assembly

(US Patent No. 5,302,805)

Inventors: **Timothy B. Morris**, **Peter F. Milly, Sr.**, and **J. Kevin White**, Marshall Space Flight Center

Many automated welding systems—such as plasma arc and gas tungsten arc—nevertheless require a human operator to manually position the filler wire while visually monitoring its contact with the base material. An innovative device senses deviations from a predetermined pressure between the filler wire and the base material, providing electrical signals to guide automatic positioning mechanisms and thereby prevent disengagement of the filler wire and base material.

For More Information Write In No. 733

Nonvolatile Programmable Neural Network Synaptic Array

(US Patent No. 5,298,796)

Inventor: **Raoul Tawel**, Jet Propulsion Laboratory

A primary need of neural network designers is a nonvolatile synaptic storage cell for analog synaptic weights. Simple, compact, and fully analog, such cells are well-suited to on-chip learning systems. Mr. Tawel has employed an X-Y array of processing synapses in VLSI MOS "floating-gate" nonvolatile analog synaptic cells. The array is based on a four-quadrant analog multiplier requiring X and Y differential input voltages, where one Y input is UV-programmable.

For More Information Write In No. 731

Simplified and Symmetrical Five-Bar Linkage Driver for Manipulating a Six-Degree-of-Freedom Parallel "Minimanipulator" With Three Inextensible Limbs

(US Patent No. 5,301,566)

Inventors: **Farhad Tahmasebi** and **Lung-Wen Tsai**, Goddard Space Flight Center

Compared to previous six-degree-of-freedom parallel manipulators, which contain six limbs, a new three-limbed design reduces the number of parts and risk of mechanical interference between limbs, and permits a closed-form solution to the direct kinematics. Further, the Goddard "minimanipulator" offers improved resolution, accuracy, and stiffness, enables a higher payload capacity and smaller actuators, and dissipates less power. The unit has three inextensible limbs attached via universal joints to a platform at noncollinear points. Each limb is attached to a two-degree-of-freedom parallel driver such as a five-bar linkage, a pantograph, or a bidirectional linear stepper motor.

For More Information Write In No. 732

Polyimides Containing the Pentafluoro-sulfanylbenzene Moiety

(US Patent No. 5,302,692)

Inventors: **Anna K. St. Clair** and **Terry L. St. Clair**, Langley Research Center

A group of polyimides containing an SF₅ moiety was formulated by reacting a diamine (1,3-diamino-5-pentafluorosulfanylbenzene) with various dianhydrides. The new compounds exhibit higher glass transition temperatures, higher densities, and lower solubilities than CF₃-containing polyimides and dielectric properties similar to those containing a CF₃ moiety. They can be used to prepare semipermeable membranes, wire coatings, and films useful for electronic, space, and piezoelectric applications.

For More Information Write In No. 734

Tough, Processable Semi-Interpenetrating Polymer Networks From Monomer Reactants

(US Patent No. 5,306,784)

Inventor: **Ruth H. Pater**, Langley Research Center

A new high-temperature, semi-interpenetrating polymer network (semi-IPN), prepared by mixing the monomer precursors of Thermid® Al-600 (a thermoset) and NR-150B2 (a thermoplastic), is more processable and damage tolerant than commercial Thermid® materials. The monomers undergo linear chain extension below 300 °C, where the resin flow is decreased and the processing window broadened, and then heated above 300 °C, where the flow is increased and crosslinking occurs at a rate that allows formation of a void-free polymer network. The new semi-IPNs are useful as high-strength polymer matrix composites, adhesives, and molded articles for aerospace and electronic applications.

For More Information Write In No. 735



©Paul Silverman, 1987, Fundamental Photographs

We took the lead, worldwide, in developing lead-free solders.

Years ago, Indium Corporation of America took the lead in developing alternative solders ... and we haven't relinquished our position since. *Now we're announcing the first*

lead-free solder that can be utilized as a replacement for the most popular lead-containing solders for electronics assembly.

Introducing Indalloy® No. 227

Indalloy No. 227 (Patented) can be used in place of Sn63Pb37, Sn62Pb36Ag2, and Sn60Pb40. It was developed to work in current assembly processes ... without changes to reflow temperatures, process chemicals, or equipment.

As evidenced by two years of testing by leading electronics manufacturing com-

panies and independent labs, users can also expect comparability in electrical conductivity, thermal conductivity, and thermal coefficient of expansion ... plus

tensile strength, component and substrate compatibility, and wettability. And thermal cycling resistance has been tested up to 2500 cycles with no failure.

Indalloy No. 227 is available in solder

paste, preforms, spheres, wire, ribbon, foil, bar, and powder. Or any other fabrication you need. So if you're looking to get the lead out, take the lead from Indium Corporation of America. Ask about our new Indalloy No. 227 or one of the other 25 lead-free and cadmium-free solders we offer.

Temperature Comparisons

	Sn60Pb40	Indalloy® #227	Sn63Pb37	Sn62Pb36Ag2
Liquidus °C	191	187	183	179
Solidus °C	183	175	183	179

Since 1934
 **INDIUM CORPORATION OF AMERICA**

CORPORATE HEADQUARTERS: 1676 Lincoln Avenue, Utica, New York 13502 USA • 315-853-No Pb (6672) or 800-433-No Pb (6672) • FAX 315-853-1000 or 800-221-5759
 INDIUM CORPORATION OF EUROPE: 7 Grisedale Court, Woburn Road Industrial Estate, Kempston, Bedford MK42 7EE, England • (0234) 840255 • FAX (0234) 841498

For More Information Write In No. 637 © 1994 Indium Corporation of America

Mission **A**ccomplished

Through the technology transfer process, many of the systems, methods, and products pioneered by NASA are reapplied in the private sector, obviating duplicate research and making a broad range of new products and services available to the public.



NASA's need to visualize large and complex data sets, such as this analysis of flow across the V-22 tiltrotor aircraft, helped spur the development of Silicon Graphics' visual computing systems.

Photo courtesy Ames Research Center

Years before computerized dinosaurs roamed Jurassic Park, before children flocked to hyperactive video arcades, or doctors performed surgery by viewing simulated anatomy, there was a small computer company called Silicon Graphics Inc. (SGI) seeking its first customers for a new 3D graphics technology.

At the same time, in the early 1980s, there was a newly-formed group of aeronautical engineers at NASA's Ames Research Center looking for a way to visualize the mountains of data generated by computational fluid dynamics (CFD) research.

"I realized there was no easy way to understand all this information except perhaps to put it on a graphics terminal," recalled Dr. Thomas Lasinski, one of the first engineers to join the Numerical Aeronautic Simulation (NAS) program set up to serve the entire US aeronautics community. "I wanted three-dimensional real-time graphics that enabled the user to manipulate the screen image instantaneously."

The NAS program's efforts to put better planes in the sky in turn helped get a future industry leader off the ground. After canvassing the available technology, NAS found its best prospect right next door at the Mountain View, CA, offices of SGI. A formal procurement process resulted in the acquisition of about 25 of the first SGI workstations at \$125,000 each. Said Lasinski. "In

those days, that was very expensive for a workstation, but NAS wanted to be a pathfinder in the use of new CFD technology."

The purchase inaugurated a mutually beneficial relationship that continues today. "They turned out to be tremendously useful machines because of the graphical visualization capability," said Dr. F. Ron Bailey, director of aerophysics at Ames and a member of the original NAS procurement team. "They also prompted us to develop a way of communicating between the workstations and Cray supercomputers."

For SGI, the contract meant access to a technologically advanced user group eager to offer advice and make demands. "NASA was always right there to constructively criticize some of our technologically convenient solutions and so, pushed the quality of the designs and products forward at a rapid rate," said Forest Baskett, SGI's senior vice president of R&D and chief technology officer. Moreover, he said, as SGI's first big customer, "NASA lent the company a lot of credibility with the business and investment communities, which enabled us to get funding for subsequent rounds of development." Today, the company's annual sales exceed \$1.1 billion.

CFD Goes 3D

The CFD field had been uniquely poised for the leap to 3D graphics simulation. "Visualization has a long history in fluid

mechanics—wind tunnel data had been visualized with water tanks or by taking photographs. So, to visualize a numerical calculation of a flow field is a very natural thing to want to do," said Lasinski, who now serves as chief of the NAS Applied Research Branch. "The calculation we do on the supercomputer is like a numerical wind tunnel and the computer graphics is like taking a videotape of that wind tunnel and playing it back."

Dr. David Cooper, chief of the NAS Systems Division, explained further: "To do a very fine calculation, you take an airplane configuration and put in as many as 50 million grid points and then solve the Navier-Stokes equations for each of these points, for each of five variables—velocity, pressure, density, etc.—obviously, you can't hand-plot these."

Software developed by both SGI and NASA, and running on the SGI machines, enables engineers to turn these massive data sets into active 3D images. Manipulating these images offers new insights into how an aircraft's design might be improved.

As anyone who has experienced virtual reality knows, no 2D image can convey the liveliness of SGI's 3D graphics, where objects look, move, and behave like objects in the real world. "It's not the pretty pictures that are the real power of these machines," stressed Lasinski. "Static images can't reveal the dynamic interplay

as the engineer or scientist manipulates the image and flow fields and sees the correlations between different parts of the flow field and image as it is rotated."

Visual computing offers similar benefits in an increasingly broad range of applications, including molecular modeling, special effects animation, and virtual reality-based entertainment. Designing products using 3D graphics can reduce costs and development cycles while spurring innovation by allowing much of the work to be done on screen and reducing the need for physical prototypes.

Over the years, the drive to improve CFD analysis prompted NAS engineers to seek specific attributes in their computer equipment, such as floating point and NTSC output capabilities. "They pushed us pretty hard on antialiasing," recalled SGI Vice President and Chief Engineer Kurt Akeley. "But we improve our machines as much from working to meet their benchmarks as from specific verbal suggestions."

Subsequent procurements and the close interchange of ideas accelerated the maturation of SGI's products, according to Bailey. "If we liked something and asked for it, they generally found their other scientific users would also want it. Also, we had some application software, such as PLOT3D, that was very popular on the SGI machines because it took advantage of the raster display manipulation capabilities."

SGI currently markets a wide range of visual computing systems, from the new Indy™ desktop system, which includes a digital color video camera, to the Onyx™ advanced graphics supercomputers, the first to incorporate multiple MIPS® RISC R4400 processors.

"NASA is still a very important customer to us. They stress our new designs in a way that helps us understand how to provide new capabilities that are actually useful to customers," said Baskett. The NAS facility currently is helping to develop software products for SGI's new Power Challenge™ supercomputer servers. Built with an eye toward NAS benchmarks, the machines employ the new MIPS® R8000 microprocessor to offer the fastest available floating point performance.

Said Lasinski: "NASA was there, investing in those early and expensive boxes and funding the company because it had good technology, so that ten years later it could produce something that's a fifth of the price with over a hundred times the graphics capability." □

For more information about the technology described in this article, contact: Silicon Graphics Inc., 2011 N. Shoreline Boulevard, Mountain View, CA 94043-1389. Tel: 415-960-1980; Fax: 415-961-0595.

NASA Tech Briefs, August 1994

Photo courtesy Ames Research Center

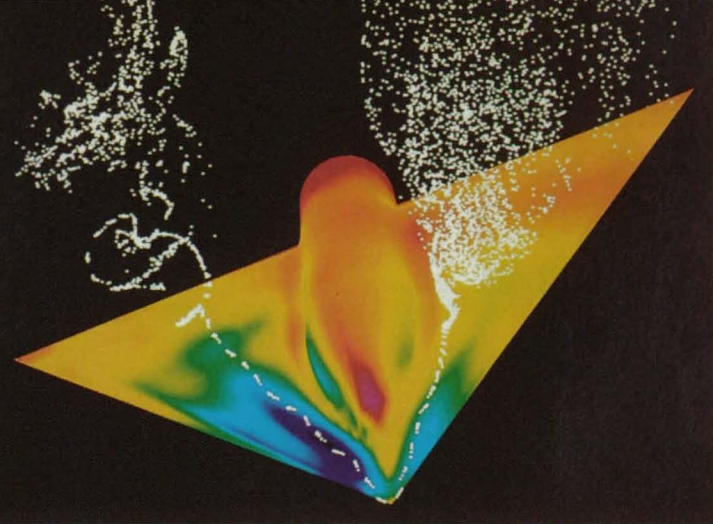

Visualization of computational fluid dynamics data enables scientists to predict vortex breakdown for a delta wing undergoing a forced roll motion at high angles of attack.

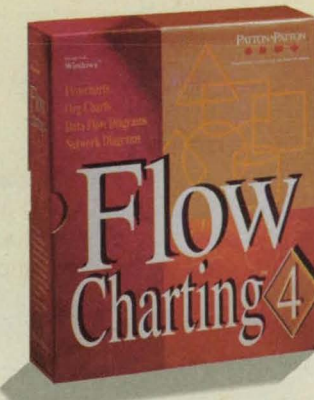

Flowcharts Any Way You Want!

Introducing Flow Charting™ 4 for Windows!

We've re-worked the basics to make flowcharting easier and more flexible than ever. We call it *sensible* technology. The end result is a flowcharting program that is incredibly powerful, yet remarkably quick to learn and use. And it's packed with everything flowcharters want. Here's a sampling:

- SensibleLines™ are totally editable. You've never experienced anything like it. Experiment with the look of your charts!
- Get your point across thanks to distortion-free shape sizing with SensibleShapes™.
- SensibleText™ — Word processing masterfully designed for flowcharts — it works the way you expect!
- Job-specific shape templates let you create the perfect chart for the task at hand.
- Snapshot™ your preferences. Your charts look great every time.

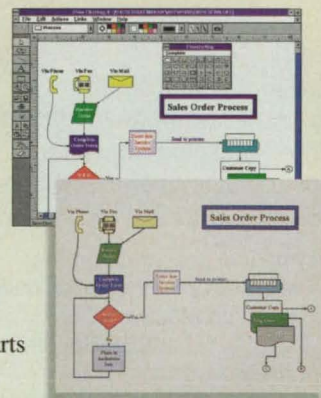

And Flow Charting 4 is backed with a 90-day no-risk guarantee. Our legendary post-buy support includes free unlimited technical support, free subscription to The Flow Charter™ and access to valuable flowcharting resources.

For flowcharts *exactly* the way you want, you need Flow Charting 4 for Windows! See your local dealer today, or for a **free** interactive demo, call now:

(800) 525-0082 ext. 284
International: (408) 778-6557

PATTON & PATTON

Excellence in charting the flow of ideas!

Patton & Patton Software Corporation 485 Cochrane Circle, Morgan Hill, CA 95037
All company and product names are trademarks or registered trademarks of their respective owners.

For More Information Write In No. 430



New Product Ideas

New Product Ideas are just a few of the many innovations described in this issue of *NASA Tech Briefs* and having promising commercial applications. Each is discussed in further on the referenced page in the appropriate section

in this issue. If you are interested in developing a product from these or other NASA innovations, you can receive further technical information by requesting the TSP referenced at the end of the full-length article or by

writing the Technology Utilization Office of the sponsoring NASA center (see page 20). NASA's patent-licensing program to encourage commercial development is described on page 20.

Deposition of Cubic BN On Diamond Interlayers

Chemical vapor deposition is proposed for coating metal-cutting tools with polycrystalline, cubic boron nitride. This type of film is second in hardness after diamond. (See page 53.)

Miniature Reversal Electron-Attachment Detector

This detector allows direct injection of air or vapor at atmospheric pressure to a mass-spectrometric instrument to detect explosives, narcotics, or other substances. (See page 46.)

Cryogenic Hybrid Magnetic Bearing

Permanent magnets provide suspension in this bearing, while electromagnets provide control. Potential terrestrial applications include gas-turbine engines, high-vacuum pumps, canned pumps, precise gimbals, and pumps that move corrosive or gritty fluids. (See page 66.)

Self-Locking Spreading Pliers

This tool applies force opposite to that of conventional pliers. One can, for example, force surfaces apart and hold them at a fixed separation or grip a tube from inside. (See page 68.)

Electrically Conductive Polyimide Films Containing Gold Surface

These films feature electrical conductivity, high reflectivity, exceptional thermal stability, and mechanical integrity. Commercial potentials besides electronics range from thin films for satellite antennas to decorative coatings. (See page 58.)

Hermetically Sealed Compressor

A new pump would compress fluid to a pressure up to 4,000 atm (400 MPa). The pump incorporates features that eliminate a major cause of friction and wear. (See page 76.)

Meet the next generation of math software ...

New Macsyma[®] 2.0

NEW Linear Algebra Power

- 180 new matrix functions
- Matlab[™]-inspired language extensions
- Matlab-to-Macsyma translator
- Numerical matrix operations faster

NEW Notebook Documents[‡]

- Combine text, math and graphics in executable documents
- 2-D formatted math, with editable input and selectable output

NEW Scientific Graphics

- Camera animated and data animated graphics
- Publication-quality labeling
- Interactive plots

- "Macsyma is a national treasure . . . Users with heavy mathematics needs should insist on Macsyma."
- IEEE Spectrum
- "Its enormity never compromises its ease of use."
- Personal Computer World
- "If you want sheer computational power, get Macsyma."
- Byte Magazine

Symbolic-Numerical-Graphical Mathematics:

Math documents, graphics, algebra, trig, calculus, differential / integral equations, numerical analysis, linear algebra, special functions, Laplace / Fourier transforms, vector / tensor calculus, programming language / compiler, Fortran / C / TeX generation.

Toroidal Coordinates with E=1, Surfaces of Constant V

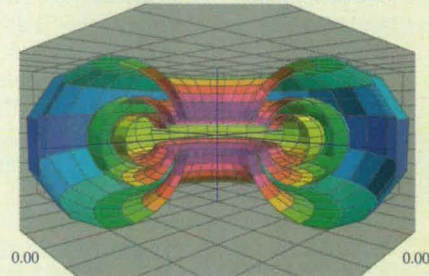

Introductory PC price \$299* / \$999 on most workstations.

Call 1-800-macsyma for a free demo or trial.

Macsyma Inc. / 20 Academy Street / Arlington, MA 02174 / U.S.A. / tel: 617-646-4550
fax: 617-646-3161 / toll free: 800-macsyma (800-622-7962) / email: info-macsyma@macsyma.com



[‡] Newest-generation notebooks and animated graphics not available on workstation versions at this time.

* Until Nov 30, 1994. Regular price \$349. Academic and quantity discounts available.

Macsyma is a registered trademark of Macsyma Inc. PDEase is a trademark of SPDE, Inc. Matlab is a trademark of The Math Works, Inc.

For More Information Write In No. 409

THE KNOWLEDGE EXPRESSWAY™

The Fast Track for Technology Transfer and Business Development



INDUSTRY

- Collaborative opportunities
- Needs & capabilities
- Technologies & products

COMMUNICATIONS

- E-Mail
- Forums
- Roundtables

FEDERAL & UNIVERSITY LABORATORIES

- Research in progress
- Scientific expertise
- Technologies

THE DIRECT ROUTE

With the power of Natural Language Processing, there is no complicated language to learn. Direct access to the largest collection of technology transfer and business development information available makes the Knowledge Expressway much more than a bulletin board of dated and unedited material. Current information and quality control helps you avoid unnecessary detours.

NEW BYPASS NOW AVAILABLE

Connect via **Internet** or modem for quick access to the Knowledge Expressway. Carpool with thousands of technology transfer professionals using electronic communications. Find solutions to your technology needs quickly and efficiently, steering clear of wrong turns that reduce productivity.

FREE ROADSIDE ASSISTANCE

With toll-free customer and technical support, cruising down the Knowledge Expressway is worry free. A Knowledge Express Technology Access Consultant will help you plan your travel on the information superhighway.

WIDENED ON-RAMPS

Small high-technology companies (under 500 employees), federal laboratories and university technology transfer offices may be eligible to participate in our National Technology & Commerce Initiative, a Technology Reinvestment Project funded by ARPA. Call us to learn more about subsidized rates with no initial fees.

Fasten Your Seat Belts!

Jump on the Knowledge Expressway and join thousands of federal laboratories, universities and technology businesses worldwide who are already in the express lane.

Knowledge Express Data Systems

900 W. Valley Road, Suite 401, Wayne, PA 19087-1830
800-248-2469 or 610-293-9712 Fax 610-687-2704



Special Focus: Computer Hardware



Fast, Massively Parallel Data Processors

Features would include an efficient interconnection scheme and options for flexible local control.

Goddard Space Flight Center, Greenbelt, Maryland

A proposed fast, massively parallel data processor would contain an 8x16 array of processing elements with an efficient interconnection scheme (see figure) for communication of data and control signals between elements in the array and between the array and external memory. Each processing element would be a data-processing subsystem in its own right, and would exert some local control of execution of instructions, independent of the local control in the other processing elements.

The interconnections between neighboring processing elements would be in the form of a diagonal or "X" grid, in which each group of four nearest neighbors would be connected to a common routing point, such that each processing element could communicate with all eight of its nearest neighbors in the logical equivalent of the eight compass directions north, northeast, east, southeast, southwest, west, and northwest. A route would be established by an operation that would send data out in one direction and accept data from one of the remaining directions. All processing elements would route data in the same direction during a given processing cycle. This scheme would enable the establishment of eight data paths by use of only four electrical paths extending out of each processing element: that is, the number of electrical interconnections would be no greater than that of a less-capable four-nearest-neighbor orthogonal (north, east, south, west) grid.

A wideband, multiple-bit input/output bus would be connected via column-select circuitry to all the processing elements in each row. The combination of the row buses and the column-select circuitry would enable communication between external memory and any or all processing elements. For example, data could be transmitted to a single processing element during one processing cycle, to a group of adjacent or nonadjacent processing elements in a row during one processing cycle, or broadcast simultaneously to all processing elements in any or all rows. To reduce data-access time further and thereby increase processing speed further, a local memory would be incorporated into each processing element.

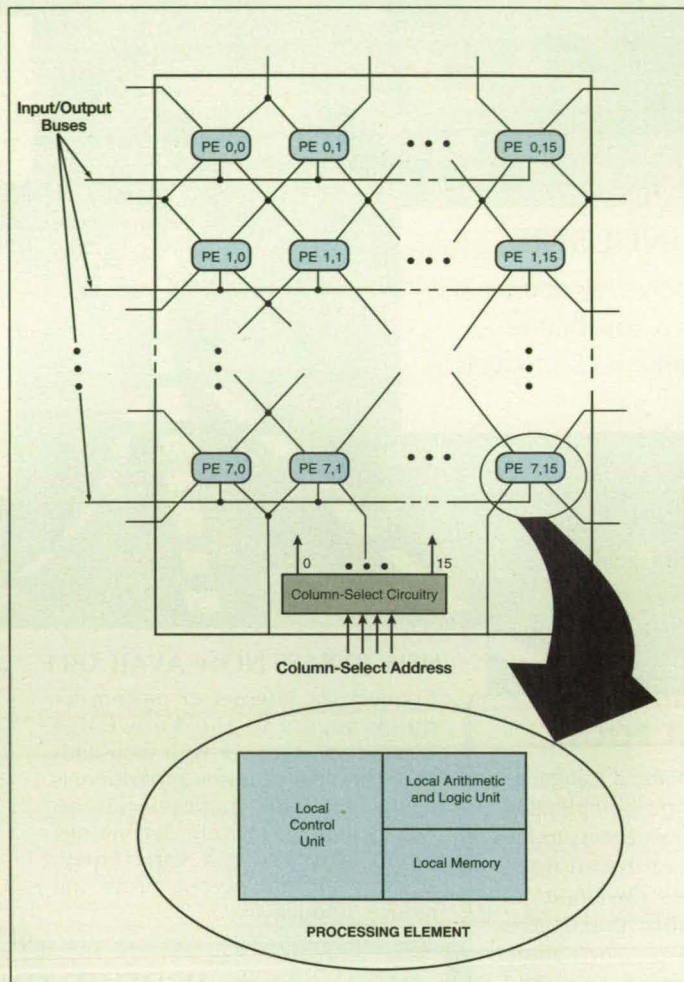

Processing Elements Would Communicate with each other on an "X" interconnection grid and with external memory via a high-capacity input/output bus.

Each processing element would modify global (that is, broadcast) instructions and exert local control to optimize execution of the instructions. A broadcast memory address could be modified in each processing element to enable access to its internal memory. Each processing element would include a bidirectional, variable-length, *N*-bit shift register that would have active and inactive segments, such that shifts would take place in active segments only during a shift cycle. The active and inactive segments would be independent of each other, allowing for temporary storage of such data as local offset addresses in the inactive segments.

Each processing element could alter a broadcast instruction that had a condi-

tional structure, so that those actions within a conditional structure that were complements of each other could be performed at the same time in different processing elements. That is, only one pass over the data would suffice for processing both conditions. This approach to conditional operation would nearly double the speed of various arithmetic operations.

This work was done by Robert A. Heaton and Donald W. Blevins of the Microelectronics Center of North Carolina and Ed Davis of North Carolina State University for Goddard Space Flight Center. For further information, write in 107 on the TSP Request Card. GSC-13304.

When information technology
is critical to your success...

networks
expo SM

Networks Expo Dallas
September 20 - 22, 1994
Dallas Convention Center

running concurrently with

Communications'94
Gateway to Global Connectivity

and

WINDOWS WORLD

you'll find IT at
Networks Expo SM Dallas.

Previously known as NetWorld[®]

- **The #1 Networking Event in the Industry**
Hundreds of vendor Exhibits, the latest networking products and thousands of live product demonstrations.
- **WINDOWS WORLD™/Dallas and COMMUNICATIONSSM '94**
Three powerhouse Exhibitions join together for an exciting forum where you can absorb technology and product offerings, from the desktop to the network and beyond to global communications. Attendees have access to all shows!
- **Corporate Educational Program**
Seminars led by the industry's top experts in the areas of Network Management, Client/Server, Internet, Mobile/Wireless, Enterprise, ATM, E-Mail, Reengineering, Desktop and Reseller/Channel Marketing.
- **NPA Free Hands-on Labs** **NPA**
Training sessions in state-of-the-art technologies such as Windows NT, WordPerfect Office 4.0, ENS for NetWare, LotusNotes, NetWare 3.12 Messaging, NetWare 4.0 and much more.
- **Messaging Pavilion**
Sponsored by ICFA (International Computer Fax Association)
Highlighting the convergence of e-mail, fax, document management, imaging and voice technologies.
- **Mobile Computing Pavilion**
Spotlighting the emergence of mobile/wireless computing technology as the fastest growing market in the industry.
- **Pavilion for NetWare[®] Solutions Products**
Showcasing the NetWare platform and its many companion products.
- **Technical Solutions Presentations**
Live software-based applications, featuring ATM, Network Management, Client/Server and Groupware.

Dallas.

The Event that
Inspired an Industry.

Call today for Attendee
or Exhibitor Information

800-829-3976, ext. 318

or mail/fax the coupon for more information.

BLENHEIM[®]

Networks Expo is produced and managed by Bruno Blenheim, Inc.

The International Powerhouse in Information Technology

Fort Lee Executive Park, One Executive Drive, Fort Lee, NJ 07024

800-829-3976 201-346-1400 Fax 201-346-1602

Networks ExpoSM is a service mark of Bruno Blenheim, Inc. NetWorld[®] is a registered trademark of Novell, Inc. NetWorld[®] is a registered trademark of Novell, Inc., which until October 14, 1993 was exclusively licensed to Bruno Blenheim, Inc. and was used by Bruno Blenheim as the name of its network computing trade show. The show is now called Networks ExpoSM. ShowNetSM is a registered trademark of Bruno Blenheim, Inc. NetWare[®] is a registered trademark of Novell, Inc. Novell, Inc. is not associated with the Products for NetWare[®]Solutions Pavilion. COMMUNICATIONSSM '94 is jointly produced and managed by Bruno Blenheim, Inc. and The Interface Group. COMMUNICATIONSSM '94 is a service mark of Bruno Blenheim, Inc. and The Interface Group. WINDOWS WORLD/Dallas Conference and Exposition is the property of INTERFACE GROUP - NEVADA, Inc. WINDOWS WORLD is produced in cooperation with Microsoft Corporation. WINDOWS WORLDSM, WINDOWS WORLD and the Windows logo are trademarks of Microsoft Corporation. WINDOWS WORLD and the Windows logo are used by Interface under license from Microsoft.

Please check (where applicable) and return this coupon by mail,
or FAX to 201-346-1602, attention Jay Gorga.

Name _____ *Please Print*

Title _____

Company _____

Address _____

City _____ State _____ Zip _____

Telephone () _____ FAX () _____

I am interested in the following information:

- Attendee Information Exhibitor Information Conference Information
- Networks Expo Dallas
September 20-22, 1994 Networks Expo Boston
February 14-16, 1995 Networks Expo San Francisco
May 2-4, 1995



HOW YOU CAN BENEFIT FROM NASA'S TECHNOLOGY TRANSFER SERVICES

If you're a regular reader of TECH BRIEFS, then you're already making use of one of the low- and no-cost services provided by NASA's Technology Transfer Program. But a TECH BRIEFS subscription represents only a fraction of the technical information and applications/engineering services offered by this Program. In fact, when all of the components of NASA's Technology Transfer Network are considered, TECH BRIEFS represents the proverbial tip of the iceberg.

We've outlined below NASA's Technology Transfer Network—named the participants, described their services, and listed the individuals you can contact for more information relating to your specific needs. We encourage you to make use of the information, access, and applications services offered.

How You Can Access Technology Transfer Services At NASA Field Centers:

Technology Utilization Officers & Patent Counsels—Each NASA Field Center has a Technology Utilization Officer (TUO) and a Patent Counsel to facilitate technology transfer between NASA and the private sector.

If you need further information about new technologies presented in NASA Tech Briefs, request the Technical Support Package (TSP). If a TSP is not available, you can contact the Technology Utilization Officer at the NASA Field Center that sponsored the research. He can arrange for assistance in applying the technology by putting you in touch with the people who developed it. If you want information about the patent status of a technology or are interested in licensing a NASA invention, contact the Patent Counsel at the NASA Field Center that sponsored the research. Refer to the NASA reference number at the end of the Tech Brief.

Lewis Research Center

Technology Utilization Officer: Anthony F. Ratajczak
Mail Stop 7-3
21000 Brookpark Road
Cleveland, OH 44135
(216) 433-5568
Patent Counsel:
Gene E. Shook
Mail Code LE-LAW
21000 Brookpark Road
Cleveland, OH 44135
(216) 433-5753

John C. Stennis Space Center

Technology Transfer Officer: Richard A. Galle
Code MA00
Stennis Space Center,
MS 39529
(601) 688-1929

Goddard Space Flight Center

Technology Utilization Officer: Dr. George Alcorn
Mail Code 702
Greenbelt, MD 20771
(301) 286-5810
Patent Counsel:
R. Dennis Marchant
Mail Code 204
Greenbelt, MD 20771
(301) 286-7351

Langley Research Ctr.

Technology Application Group
Dr. Joseph S. Heyman,
Acting Director
Mail Stop 118
Hampton, VA 23681-0001
(804) 864-6005
Patent Counsel:
Dr. George F. Helfrich
Mail Stop 212
Hampton, VA 23681-0001
(804) 864-3521

Ames Research Ctr.

Office of Commercial Technology Director:
Dr. Syed Z. Shariq
Mail Code 200-11
Moffett Field, CA 94035
(415) 604-6406
Patent Counsel:
Darrell G. Brekke
Mail Code 200-11
Moffett Field, CA 94035
(415) 604-5104

NASA Headquarters

Technology Utilization Officer: Leonard A. Uult
Code CU
Washington, DC 20546
(202) 358-0721
Associate General Counsel for Intellectual Property: Jack Mannix
Code GP
Washington, DC 20546
(202) 358-2424

George C. Marshall Space Flight Center

Technology Transfer Officer: Harry G. Craft Jr.
Code LA20
Marshall Space Flight Center,
AL 35812
(205) 544-0963
(800) 437-5186
Patent Counsel:
Robert L. Broad, Jr.
Mail Code CC01
Marshall Space Flight Center,
AL 35812
(205) 544-0021

Dryden Flight Research Facility

Project Manager, Technology Transfer Office: Yvonne Kellogg
Mail Stop D-2131
P.O. Box 273
Edwards, CA 93523-0273
(805) 258-3720

John F. Kennedy Space Center

Technology Utilization Officer: James A. Aliberti
Mail Stop DE-TDO
Kennedy Space Center, FL 32899
(407) 867-3017
Patent Counsel:
Bill Sheehan
Mail Code DE-TDO
Kennedy Space Center, FL 32899
(407) 867-2544

Lyndon B. Johnson Space Center

Technology Transfer and Commercialization Office, Deputy Director Robert Dotts
Mail Code HA
Building 1
Houston, TX 77058
(713) 483-3809
Patent Counsel:

Edward K. Fein
Mail Code HA
Houston, TX 77058
(713) 483-4871

Jet Propulsion Lab.

NASA Management Office
Technology Utilization Officer: Arif Husain
Mail Stop 180-800C
4800 Oak Grove Drive
Pasadena, CA 91109
(818) 354-4862
Patent Counsel:
Thomas H. Jones
Mail Code 180-802B
4800 Oak Grove Drive
Pasadena, CA 91109
(818) 354-5179

Technology Utilization Mgr. for JPL:
Wayne Schober
Mail Stop 122-116
4800 Oak Grove Drive
Pasadena, CA 91109
(818) 354-2240

How You Can Utilize NASA's Regional Technology Transfer Centers (RTTCs)—A nationwide network offering a broad range of technology transfer and commercialization services.

You can contact NASA's network of RTTCs for assistance in solving a specific technical problem or locating technology or markets that match your interests. The RTTCs are experienced in working with industry to define technology needs and acquire and commercialize applicable technology. User fees are charged for most services. For more information, call 1-800-472-6785 and you will be connected to the RTTC in your geographical region (or you may call or write directly to the RTTC in your region).

REGIONAL TECHNOLOGY TRANSFER CENTERS (RTTCs)

RTTC Directors

NORTHEAST

Dr. William Gasko
Center for Technology Commercialization
Massachusetts Technology Park
100 North Drive
Westborough, MA 01581
(508) 870-0042

MID-ATLANTIC

Ms. Lani S. Hummel
University of Pittsburgh
823 William Pitt Union
Pittsburgh, PA 15260
(412) 648-7000
(800) 257-2725 (toll-free US)

SOUTHEAST

Mr. J. Ronald Thornton
Southern Technology Application Center
University of Florida
College of Eng.
Box 24
One Progress Boulevard
Alachua, FL 32615
(904) 462-3913
(800) 225-0308 (outside FL)

MID-CONTINENT

Mr. Gary Sera
Texas Engineering Extension Service
Texas A&M University System
301 Tarrow Street
College Station, Texas 77843-8000
409-845-8762

MID-WEST

Dr. Joseph W. Ray
Great Lakes Industrial Technology Center
25000 Great Northern Corporate Center
Suite 260
Cleveland, OH 44070-5331
(216) 734-0094

FAR-WEST

Mr. Robert Stark
Technology Transfer Center
University of Southern California
3716 South Hope Street,
Suite 200
Los Angeles, CA 90007-4344
(213) 743-6132
(800) 642-2872 (CA only)
(800) 872-7477 (toll-free US)

If you are interested in information, applications, research, training, and services relating to satellite and aerial data for Earth resources, contact NASA's transfer point for earth observing technology: **Earth Data Analysis Center, University of New Mexico, 2500 Yale Blvd. S.E., Suite 100, Albuquerque, NM 87131-6031; Dr. Stan Morain, Director (505) 277-3622.**

If you represent a public sector organization with a particular need, you can contact NASA's Application Team for technology matching and problem solving assistance. Staffed by professional engineers from a variety of disciplines, the Application Team works with public sector organizations to identify and solve critical problems with existing NASA technology. **Technology Application Team, Research Triangle Institute, P.O. Box 12194, Research Triangle Park, NC 27709; Dr. Doris Rouse, Director, (919) 541-6980**

A Shortcut To Software: COSMIC®—For software developed with NASA funding, contact COSMIC, NASA's Computer Software Management and Information Center. New and updated programs are announced in the Computer Programs section. COSMIC publishes an annual software catalog. For more information call or write: COSMIC®, 382 East Broad Street, Athens, GA 30602 John A. Gibson, Director, (706) 542-3265; FAX (706) 542-4807.

If You Have a Question..NASA Center For AeroSpace Information can answer questions about NASA's Technology Transfer Network and its services and documents. The CASI staff supplies documents and provides referrals. Call, write or use the feedback card in this issue to contact: NASA Center For AeroSpace Information, Technology Transfer Office, 800 Elkridge Landing Rd, Linthicum Heights, MD 21090-2934. Walter M. Heiland, Manager, (410) 859-5300, Ext. 245.

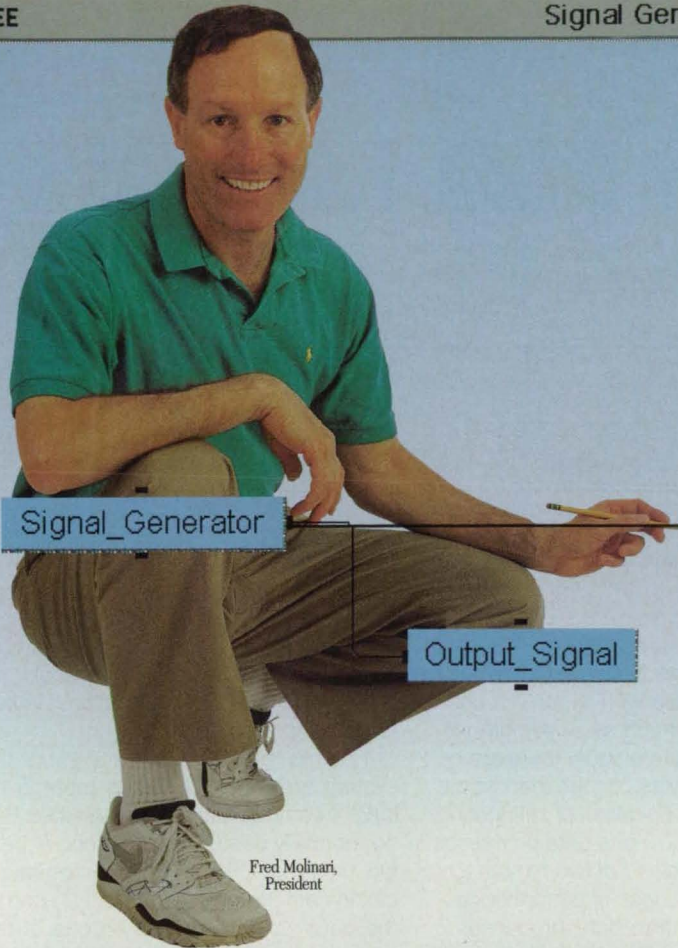

Signal_Generator

Output_Signal

Fred Molinari,
President

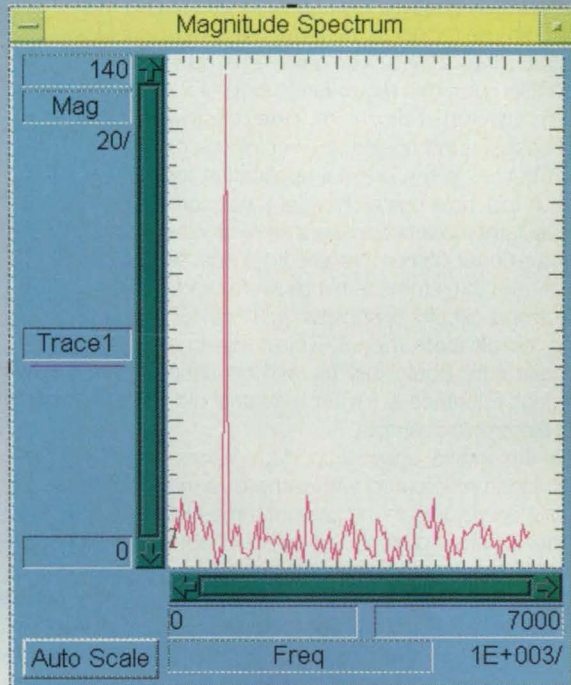

DT VEE, Easy as Connect-the-Dots

GET DATA FAST AND EASY!

A complete application
in three simple steps

A/D Config → Get Data / Ch 1 →

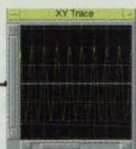

- Quick to learn, easy to use
- Powerful data analysis and display
- 100% Windows: simplified interface, DDE
- Flexible application development and maintenance
- No time-consuming compiling—ready to run

Speed your application development with DT VEE™ for Windows.™ DT VEE is a complete graphical programming approach that lets you create sophisticated data acquisition applications without ever writing code.

With DT VEE, you easily create, debug, and document. Program development is intuitive—simply connect function-specific objects in a logical sequence and run. It's that easy.

With more than 180 analysis functions, comprehensive display capabilities, and full hardware support, DT VEE has everything you need for data acquisition. DT VEE is based on HP VEE for Windows,™ and is backed by the Hewlett-Packard and Data Translation commitment to quality.

**Call 1-800-525-8528 today (In USA and Canada).
FREE DT VEE evaluation version available.**



Half Price!
All VEE Products
Limited Time Offer.
Call Today!

Redundant Buses for Loosely Coupled Dual Computers

One computer can take over if the other fails.

Goddard Space Flight Center, Greenbelt, Maryland

The figure illustrates a digital electronic network that contains two data processors loosely coupled to each other and to four remote terminals via three MIL-STD-1553B data buses. The three-bus configuration provides redundancy for protection against failure of one of the processors and against failures of one or two buses. In the original application for which this triple-bus architecture was conceived, the data processors were single-circuit-board computers aboard a spacecraft, and the remote terminals were digital electronic circuits associated with various spacecraft instruments. This triple-bus architecture could just as well be used for fault tolerance in similar terrestrial digital electronic systems.

In the original application, data processor 1 communicated with remote terminals 1 and 2 only. In the present three-bus system, data processor 1 is still dedicated primarily to remote terminals 1 and 2; normally, these three units communicate via their A ports, which are connected to bus C. Similarly, in the original application, data processor 2 communicated with remote terminals 3 and 4 only. In the present three-bus system, data processor 2 is still dedicated primarily to remote terminals 3 and 4; normally, these three units communicate via their A ports, which are connected to bus A.

To provide the desired redundancy, bus B is connected to the B ports of both data processors and all four remote terminals. During normal operation, bus B is not used. If either data processor 1 or data processor 2 fails, it is isolated from bus C,

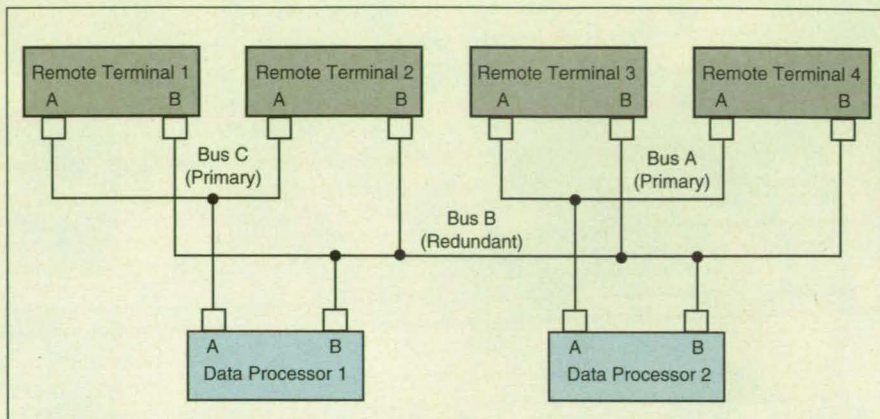

Bus B Provides Redundancy for protection against failure of one of the processors or of either or both of buses A and C.

and its functions are performed by the remaining functional data processor, which then communicates with all remote units over bus B. Inasmuch as all remote-terminal addresses are unique, there are no addressing conflicts. Other than some reduction in the allocation of computing power (because now one data processor must serve four instead of two remote terminals), there is no loss of performance.

If bus A fails, then data processor 2 can communicate with remote terminals 3 or 4 via bus B, while data processor 2 continues to communicate, in the normal way, with remote terminals 1 and 2 via bus C. Similarly, if bus C fails, data processor 1 can communicate with remote terminals 1 and 2 via bus B, while data processor 2 continues to communicate, normally, with remote terminals 3

and 4 via bus A. Again, because addresses are unique, the remote terminals not meant to receive communications on bus B can simply ignore them.

If bus B fails but all other parts of the system are functional, then there is no loss of communication because bus B is not normally used. If buses A and C both fail, then bus B is used for all communications among all units. If both (1) one of the data processors and (2) one of the primary buses (bus A or bus C) fail, then the remaining functional data processor and bus B can take their places.

This work was done by Richard B. Katz and Michael D. Blau of Goddard Space Flight Center and Igor Kleyner of General Electric Corp. For further information, write in 69 on the TSP Request Card. GSC-13623.

High-Speed Optical Wide-Area Data-Communication Network

Congestion would be relieved through dynamic interconnection of multiple routing planes.

NASA's Jet Propulsion Laboratory, Pasadena, California

A proposed fiber-optic wide-area network (WAN) for digital communication would balance input and output flows of data with its internal capacity by routing traffic via dynamically interconnected routing planes. Data would be transmitted optically through the network by wavelength-division multiplexing in synchronous or asynchronous packets. This WAN could be implemented with currently available technology. In computer simulations, a network of this type successfully routed all input packets

at 1.5 times the theoretical minimum routing latency.

The network would be a multiple-ring cyclic shuffle exchange network (see Figure 1), which would ensure that traffic reaches its destination with a minimum number of hops. Switching nodes within the network would make routing decisions to alleviate congestion by deflecting interfering packets to alternative layers in the shuffle exchange network. This scheme uses permutation engine (PE) switching

nodes, which provide constant routing latency through distributed control of a mesh topology and are well suited to an all-optical data path network. Specifically, the switching nodes operate in a bit-synchronous, packet-asynchronous mode (meaning incoming packets need only be reclocked for bit alignment but not for packet alignment). The distributed control and switching hardware for this crossbar could be built using current electronic and/or optical/electro-optic technology.

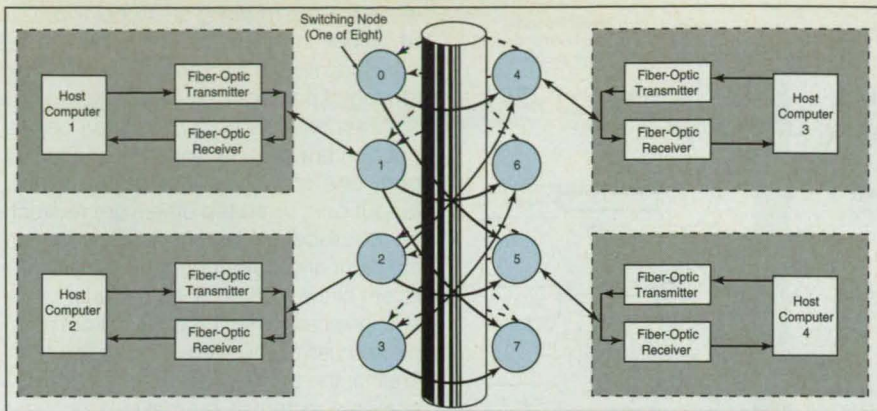

Figure 1. This **Four-Ring Shuffle Exchange Network** would contain eight switching nodes, four of which are used as input/output nodes.

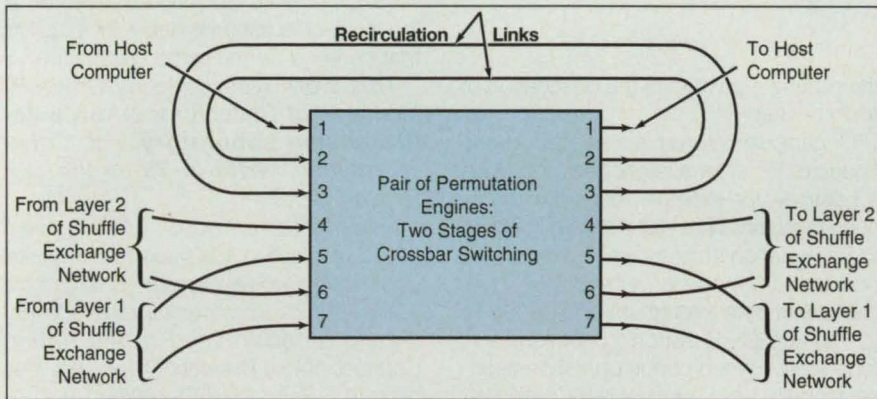

Figure 2. Two **Recirculation Links** in a switching node would provide for a two-stage queue with first-in/first-out characteristics.

For a single-ring shuffle exchange network, 3-by-3 switching nodes are needed to accommodate two network ports and a host port. An m -ring shuffle exchange network requires $(2m + 1)$ -by- $(2m + 1)$ switching nodes for one host port and ports per ring. The mesh topology and distributed routing algorithm make the

switching nodes expandable in increments of one input/output connection to provide the flexibility needed to accommodate the m -ring shuffle exchange topology.

The constant routing delay of a switching node also provides a simple relation between the number of hops a packet makes through the shuffle exchange net-

work and the routing delay through the network. Here a hop corresponds to each switching node a packet must traverse in routing from any network input to any network output. The important point is that the average routing delay through the network is known given the expected number of hops for the shuffle exchange topology. The ratio of this delay to the time it takes to input a packet into the network determines the number of rings needed for crossbarlike operation at the network level.

Contention at a network output port is handled by recirculating queues. A recirculating queue can be implemented at each switching node (see Figure 2) by increasing the number of input/output ports by one for each queue. The extra input/output ports would be connected in a wraparound fashion allowing those packets that were not able to leave the node through the port to the host computer ("host port") to reenter the destination node. Thus, packets that were blocked from the host port at the destination node could try again without recirculating through the shuffle exchange network. The strategy would be followed to avoid packet deflections whenever possible, albeit at the expense of increased mean routing latency.

This work was done by Steve P. Monacos of Caltech for NASA's Jet Propulsion Laboratory. For further information, write in 73 on the TSP Request Card.

This invention is owned by NASA, and a patent application has been filed. Inquiries concerning nonexclusive or exclusive license for its commercial development should be addressed to the Patent Counsel, NASA Resident Office—JPL [see page 20]. Refer to NPO-18983.

Crossbar Switches for Optical Data-Communication Networks

Nonblocking operation is achieved by a decentralized switching and control scheme.

NASA's Jet Propulsion Laboratory, Pasadena, California

Optoelectronic and electro-optical crossbar switches called "permutation engines" (PE's) are being developed to route packets of data through fiber-optic communication networks. The basic network concept is described in the preceding article, "High-Speed Optical Wide-Area Data-Communication Network" (NPO-18983). The basic design of a permutation engine is defined by a nonblocking crossbar topology and a distributed routing algorithm (that is, a routing algorithm that does not require complicated centralized electronic control circuitry, which could constrict switching speed).

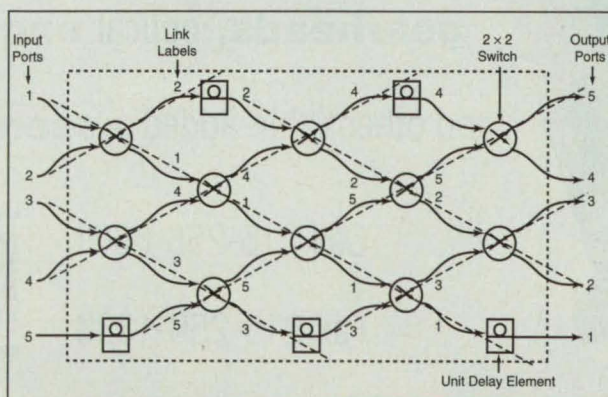
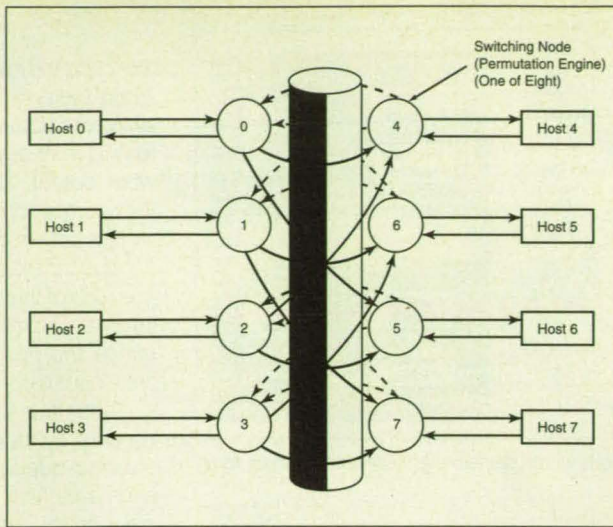

Figure 1. **Each Packet Is Routed Up or Down** in each column of this 5-input/5-output permutation engine. The routing algorithm ensures that each packet arrives at its designated output port without blocking any other packet that does not contend for the same output port.

Figure 2. The **Single-Ring SN** is a unidirectional, wrap-around topology with 3×3 switching nodes. The direction of data flow is depicted by the arrows. One pair of node I/O ports connect to the host device with the remaining I/O ports connecting to other SN nodes.



A permutation engine operates in a bit-synchronous, packet-asynchronous mode, meaning that incoming packets need only be relocked for alignment of bits but not for alignment of packets. The term "permutation engine" represents the ability of the routing algorithm and crossbar topology to sort any permutation of destinations while packets are in transit through the matrix, so that packets reach the proper output ports of the crossbar matrix (see Figure 1). The only input required by

the routing algorithm is the destination of each packet.

Of particular interest is a switching node (made of PE's) for a larger network. Such a network, for example, could be the 8-node cyclic shufflenet (SN) shown in Figure 2. Permutation engines are located at the nodes of the network, where they route packets of data through the links of Figure 2. The use of PE switching nodes allows for packet asynchronous operation needed to build an all-optical data path net-

work. For the multiring shufflenet topology described in the preceding article, the PE switching nodes also provide for dynamic routing of packets between rings.

When packets from more than one input port are destined for the same output port, one of the packets is sent to that output port, while the others are redirected to adjacent output ports. By connecting input and output ports to various ring layers in the multiple-ring shufflenet topology, one can buffer the packets from multiple sources to the same destination host. That is, the excess packets are essentially stored in transit by making each one detour through the network until its turn to be received at the destination. To state it yet another way, blocking is prevented at the cost of additional delay for packets that contend for the same destination.

This work was done by Steve P. Monacos of Caltech for NASA's Jet Propulsion Laboratory. For further information, write in 78 on the TSP Request Card.

This invention is owned by NASA, and a patent application has been filed. Inquiries concerning nonexclusive or exclusive license for its commercial development should be addressed to the Patent Counsel, NASA Resident Office- JPL [see page 20]. Refer to NPO-18864.

Pittman® brush-commutated DC motors

improve the **reliability** and **performance** of your designs. Choose

from **four** series, **1.18"** to **2.13"** diameter. Continuous-

duty torques from **1.2** to **32 oz.-in.**

Options include spur or planetary

gearheads, optical **encoders**, **EMI filters**,

and other value-added **assemblies.**



Call 215-256-6601

Fax 215-256-1338

PITTMAN®
HARLEYSVILLE, PA 19438-0003 USA
A DIVISION OF PENN ENGINEERING & MANUFACTURING CORP.

Multiple Pages Intentionally Left
Blank



Electronic Components and Circuits

Multiconductor Short/Open Cable Tester

This inexpensive circuit simplifies open/short testing and is amenable to automation.

Lewis Research Center, Cleveland, Ohio

Frequent or regular testing of multiconductor cables terminated in multipin connectors can be a tedious, if not impossible, task. This is especially true if the cables must be tested for both open and short circuits for all of the various combinations of conductors. The inexpensive circuit shown in the figure simplifies the task.

The source of power for this cable-testing circuit is a small 120-Vac-to-5-Vdc, 250-mA power supply. Light-emitting diodes (LED's) with built-in current-limiting resistors for 5-V operation are used throughout the circuit as indicators.

In operation, a pair of connectors is selected to match the pair of connectors installed on each of the cables to be tested. As many connectors can be accommodated as required, and each can have as many conductors as required.

A single-pole/single-throw (SPST) toggle switch is provided for each conductor of whichever cable in the system has the greatest number of conductors. One side of each switch is tied to the positive side of the 5-V power supply. The other side is fed to one of the connectors indicated as J1 through J3 in the schematic diagram. These are designated as output connectors in the system.

A mating connector, designated as the input connector for the other side of each cable is provided. The connectors of this class are identified as J4 through J6 in the schematic diagram. One conductor of each of the output connectors is connected in parallel to the anode of an LED. One LED is required for each conductor of the cable that has the greatest number of conductors. The cathodes of the LED's are tied together and connected to the common side of the 5-V power supply.

At the beginning of a test, all of the switches are turned off. First, one turns on power switch S5 and verifies that LED5 illuminates. Then one turns on switches S1 through S4, one at a time. Only the LED corresponding to the switch that is on should illuminate. The current flows through the switch to the output connector, through the cable to the input connector, through the LED, and back to the power supply. An open conductor in the test cable is indicated if the corresponding LED is not illuminated. A short circuit is indicated if

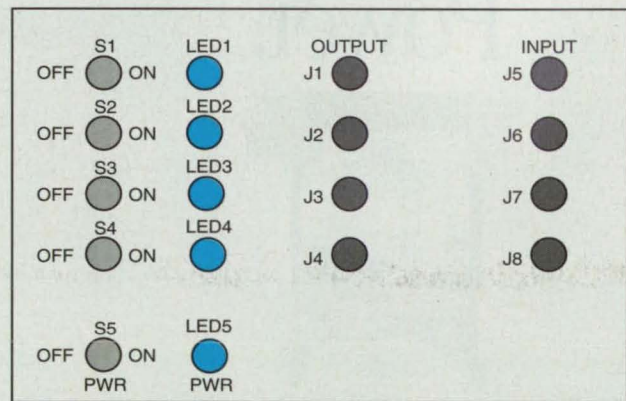
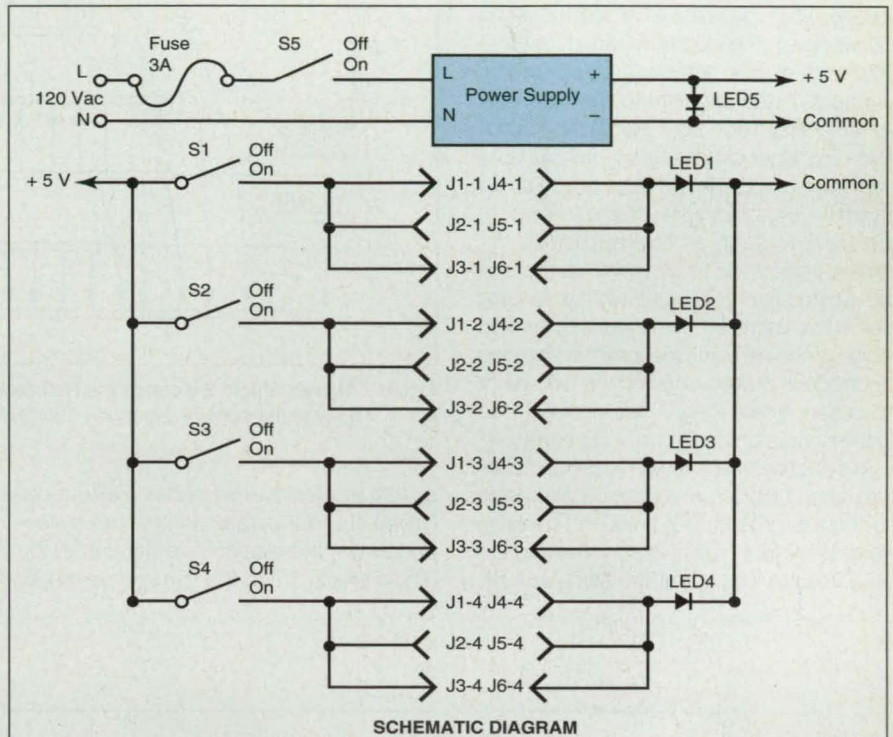

PANEL LAYOUT

This Circuit Simplifies the Testing of multiconductor cables terminated in multipin connectors.

any other than the corresponding LED is illuminated. Thus, the fault is easily identified as lying in the specific conductors involved, so that a repair or replacement can be made as required.

The testing technique implemented with this circuit can be automated easily with electronic controls and a computer inter-

face. A printout can provide the status of each conductor in a cable, indicating which, if any, of the conductors has an open or short circuit.

This work was done by Dennis Eichenberg of Lewis Research Center. No further documentation is available. LEW-15728.

Capacitive Sensor With Driven Shields and Bridge Circuit

Unbalance in the bridge circuit reveals proximity of an object.

Goddard Space Flight Center, Greenbelt, Maryland

Figure 1 illustrates the electric-field configuration of a capacitive proximity sensor of the "capaciflector" type. Like other capaciflectors described in prior articles in *NASA Tech Briefs*, this one includes a sensing electrode driven by an alternating voltage, which gives rise to an electric field in the vicinity of the electrode; an object that enters the electric field can be detected by its effect on the capacitance between the sensing electrode and electrical ground. Also like other capaciflectors, it includes a shielding electrode (in this case, driven shield 1), which is excited via a voltage follower at the same voltage as that applied to the sensing electrode to concentrate more of the electric field outward from the sensing electrode, increasing the sensitivity and range of the sensor. Because the shielding electrode is driven via a voltage follower, it does not present a significant electrical load to the source of the alternating voltage.

In this case, the layered electrode structure also includes a reference electrode adjacent to ground, plus a second shielding electrode (driven shield 2), which is excited via a voltage follower at the same voltage

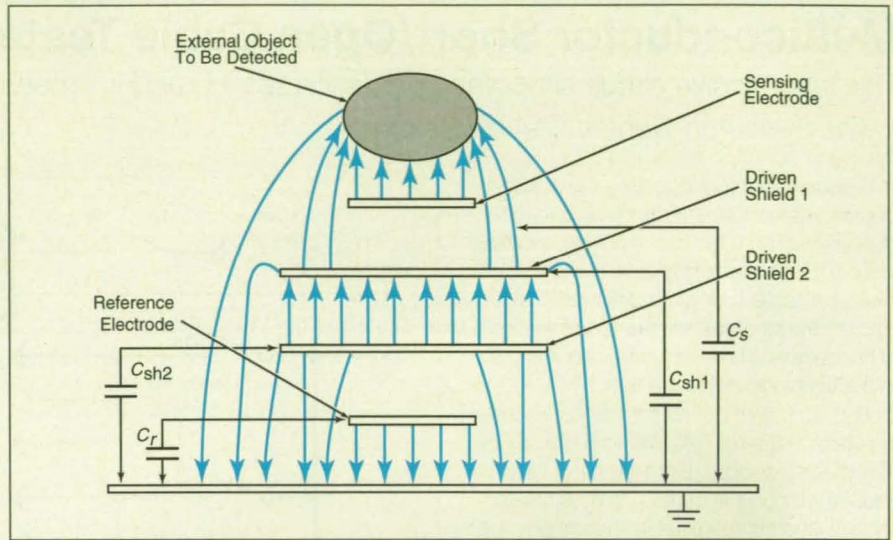

Figure 1. Driven Shield 2 isolates the Reference Electrode from capacitive effects of an object in the vicinity of the sensing electrode and of driven shield 1.

as that applied to the reference electrode. Driven shield 2 isolates the reference electrode from the electric field generated by driven shield 1 and the sensing electrode,

so that a nearby object exerts no capacitive effect on the reference electrode.

The excitation is supplied by a crystal-controlled oscillator and applied to the sens-

Power.

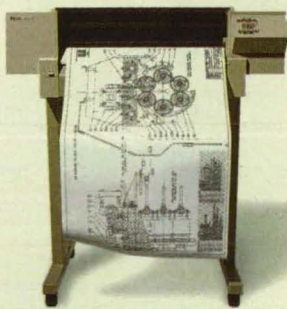

5 minute plots

Now, with a new low price, the HP DesignJet 200 monochrome inkjet plotter is more affordable than ever.

It's true. For about the price of the average pen plotter, the HP DesignJet 200 gives you crisp, 300-dpi, D-size plots in under five minutes.

Of course, HP's proven inkjet technology means more than just fast plotting. It means no more pen-related problems. No more skipped lines. No more pen clogging. And our smooth, quiet writing

ing and reference electrodes via a bridge circuit, as shown in Figure 2. Fixed capacitors C_1 and C_2 (or, alternatively, fixed resistors R_1 and R_2) are chosen to balance the bridge; that is, to make the magnitude of the voltage at the sensing-electrode node S equal the magnitude of the voltage at the reference-electrode node R.

The voltages at S and R are peak-detected and fed to a differential amplifier, which puts out voltage V_U proportional to the difference between them. When no object intrudes into the electric field of the sensing electrode, the bridge remains in balance, and $V_U = 0$. When an object intrudes, it changes C_s , unbalancing the bridge and causing V_U to differ from zero. The closer the object comes to the sensing electrode, the larger $|V_U|$ becomes.

An additional output voltage KV_r is available, where K is the amplification factor of a noninverting amplifier and V_r is the voltage on the reference electrode. Inasmuch as V_{ref} would not ordinarily change much during operation, a drift in KV_r could serve as a measure of thermal drift in the noninverting amplifier. If all the amplifiers are located on a common circuit board so that they are subject to the same changing thermal conditions, the change in KV_r can thus serve as a measure of thermal drift in the sensor circuit as a whole.

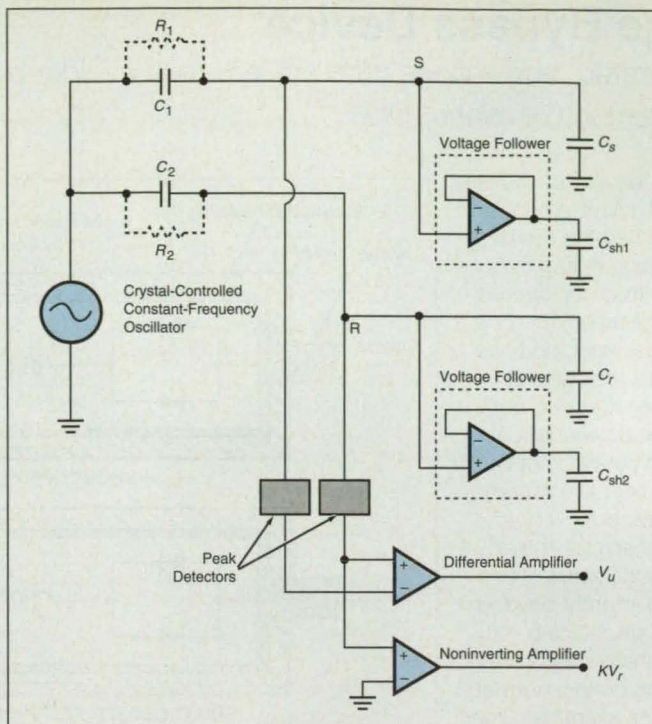

Figure 2. **Unbalance in the Bridge Circuit** gives rise to nonzero V_U , which serves as a measure of proximity of an external object to the sensing electrode.

This work was done by John M. Vranish of Goddard Space Flight Center. For further information, write in 20 on the TSP Request Card.

This invention is owned by NASA, and a patent application has been filed. Inquiries

concerning nonexclusive or exclusive license for its commercial development should be addressed to the Patent Counsel, Goddard Space Flight Center [see page 20].

Refer to GSC-13541.

To the people.

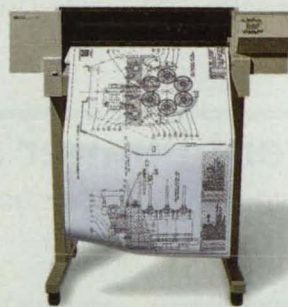

\$2,995*

HP makes the HP DesignJet 200 for any office environment. And with the addition of legs, the DesignJet converts from a desktop to a free-standing plotter.

So get the plotter that saves you as much time as it does money. Call 1-800-851-1170, Ext. 7720 for the location of your local HP demo dealer!

**hp HEWLETT®
PACKARD**

*E-size model priced at just \$3,995. Suggested U.S. list prices. Price does not include optional legs and bin. Plot images courtesy of Autodesk, Inc. †In Canada, call 1-800-387-3867, Ext. 7720. ©1994 Hewlett-Packard Company PE12402

For More Information Write In No. 416

Low-Voltage Bypass Device

Weight, heat generated, and voltage drop are less than in older bypass devices.

Lewis Research Center, Cleveland, Ohio

An improved bypass device provides a low-resistance current shunt around a low-voltage power cell when the cell fails in the open-circuit condition during operation. In comparison with older bypass devices for the same application, this one weighs less, generates less heat, and has a lower voltage drop (less resistance).

The bypass device (see figure) is connected in parallel with the power cell. The two diodes connected in parallel in opposite polarities serve to limit the current through the bypass device to very low values until the voltage across the cell and bypass device exceeds either of two specified limits that are slightly beyond the normal charging and discharging voltages of the cell. That is, the bypass circuit draws very little current during normal operation of the cell. For example, one diode could be chosen to allow significant current to flow when the voltage during charging of the cell exceeds 1.5 V, while the other diode could be chosen to allow significant current to flow when the discharge drives the cell to or beyond 0.5 V reverse polarity.

When the voltage begins to exceed either limit, significant current begins to flow through one of the diodes and through the tension spring, which is made of a shape-memory alloy (nickel and titanium, for example). When the current heats the spring beyond the transition temperature of the shape-memory alloy, the spring goes from its relatively relaxed condition to a more taut condition, in

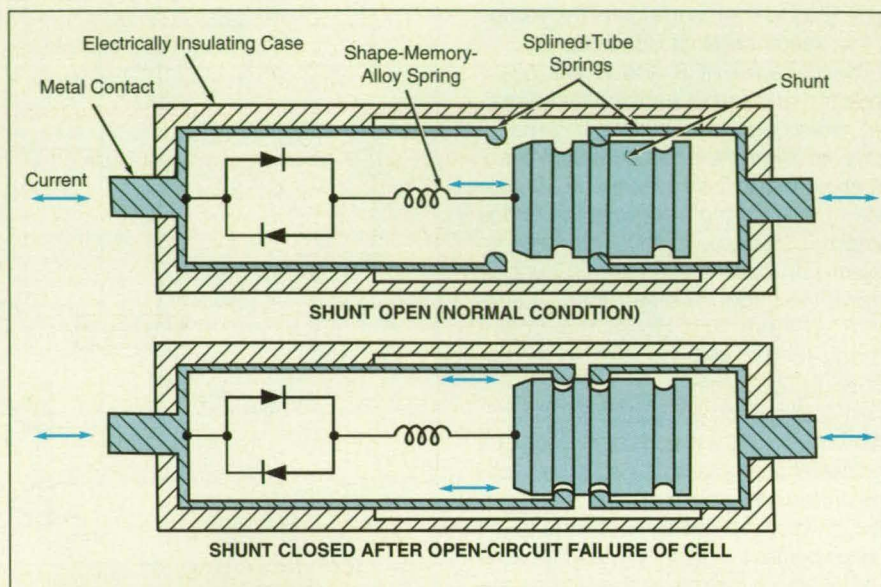

The **Low-Voltage Bypass Device** creates a low-resistance electrical path around a power cell when the cell fails in the open-circuit condition.

which it was fabricated (when heated, it exerts a strong force tending to return it to its "remembered" fabricated shape).

The sudden increase in spring tension is sufficient to pull the shunt away from its initial detent position in contact with the right set of splined-tube springs and into a new detent position in contact with both sets of splined-tube springs. In the new detent position, the shunt completes an electrical path around the diodes, thus providing a low-resistance electrical path in

parallel with the cell. When the electrical heating of the spring ceases and the spring cools to below the transition temperature, the shunt remains in the new detent position, continuing to provide a low-resistance path around the cell.

This work was done by J. P. Wilson, Consultant to Ford Aerospace and Communications Co., for Lewis Research Center. For further information, write in 10 on the TSP Request Card. LEW-15220.

Inrush-Current Limiter and Bus Isolator

The power bus is protected against excessive transient and steady current demands.

Marshall Space Flight Center, Alabama

The figure illustrates an electronic circuit that protects an electrical power bus and the source of power against excessive current demands. This circuit is intended for use with a power-consuming electronic system that draws pulsed currents and that includes a capacitor bank as a low-impedance secondary source from which the pulsed currents can be drawn.

Because the capacitor bank also acts as a low-impedance load on the bus, the peak current that it draws from the source when power is first applied or when there is a positive transition in bus voltage is

limited (in the absence of a protective circuit) only by the output impedance of the source and by the impedance of an electromagnetic-interference filter (if any) in series with the source and bus.

The protective circuit comprises three functional blocks: a resettable timer, latch, and current source; an overload detector; and a bus-voltage-droop detector. The circuit performs the following three functions:

1. It limits the inrush current that flows upon the application of power and after transients in bus voltage.

2. It disconnects the power bus from the power-consuming system when (a) the link voltage (the voltage at a designated point in the system) fails to reach a predetermined fraction of the input voltage within a preset time, (b) the power supply fails to operate, or (c) the load current exceeds a preset value.

3. When the bus voltage falls to a predetermined fraction of the input voltage, it issues a discrete signal that can inhibit the operation of the system.

This work was done by Carlisle R.

Dolland of Allied-Signal Aerospace Co.
for **Marshall Space Flight Center**. For
further information, **write in 57** on the

TSP Request Card.

Inquiries concerning rights for the com-
mercial use of this invention should be

addressed to the Patent Counsel,
Marshall Space Flight Center [see page
20]. Refer to MFS-28677.

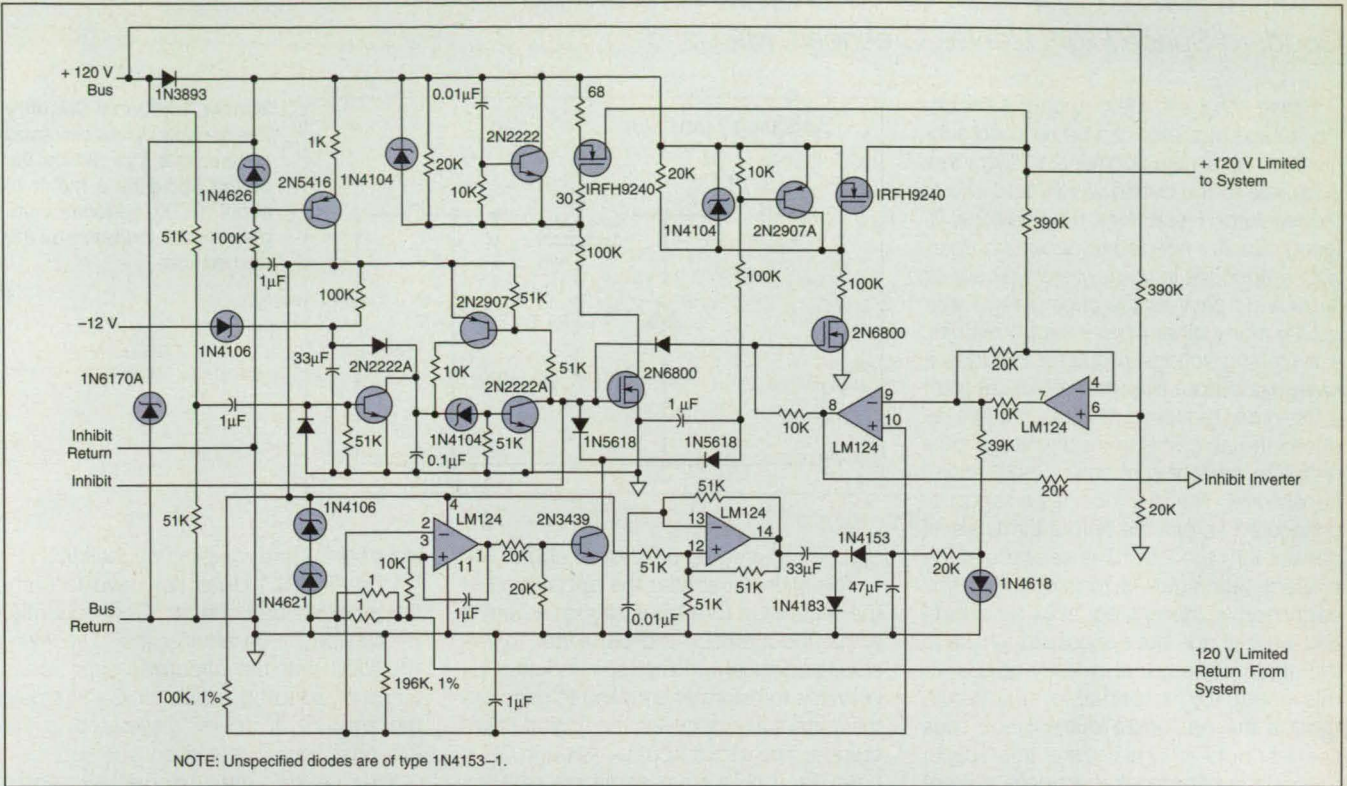

This Inrush-Current Limiter and Bus Isolator protects a power bus against excessive current demands imposed by a pulsed-current load.

Get back to the business of problem solving

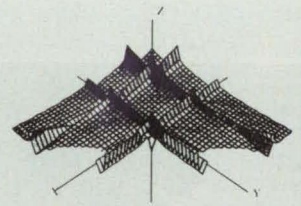

NAG software products enable you to spend your time and talents on genuine problem solving, not software development. Over 280 experts, recognized worldwide as the leaders in their fields, create the solutions in NAG's software. With 23 years experience in crafting state-of-the-art software, the robustness, performance and functionality of NAG software are unmatched. Benefit from NAG's expertise by using any of these quality products, today!

NAG Fortran Library

With nearly 1200 user-level routines available, the NAG Fortran Library is the largest, most comprehensive commercial numerical library in the world! Routines included; all BLAS, optimization, ODEs, PDEs, quadrature, special functions, OR, analysis of variance, regression, FFTs, curve and surface fitting and **much more!** Top performance on over 40 platforms, from PCs to Supercomputers. Let NAG help you reduce development and porting time, and increase accuracy and performance. Call us today!

NAG Fortran 90 Compiler

NAG produced the world's first Fortran 90 compiler in 1991. With thousands of users, it is still the leader in quality and robustness. Conforming to both the ISO and ANSI standards for Fortran 90, NAG Fortran 90 lets you maintain your investment in Fortran 77, while benefiting from modern trends in language design. So take advantage of array operations, pointers, dynamically allocatable storage, derived types, data structures, modules and many, many new features, today!

NAG C Library

For users who prefer using the C language for writing their modeling, simulations, and analysis, the NAG C Library offers the same numerical capabilities of our Fortran Libraries. For everything from the BLAS, ODEs, optimization, integration, FFTs, OR, time series, filtering and much more! Decrease development time, increase your accuracy and confidence in your results! No license manager to slow you down. Source code is available.

NAG f90 Library

From the folks who brought you the world's first Fortran 90 Compiler, comes NAG f90. NAG f90 is the world's first numerical procedure library and provides a comprehensive suite of software for scientific computation in Fortran 90. NAG f90 has been designed from the outset to capitalize on the increased functionality, power and simplicity of Fortran 90 - the new Fortran standard.

NUMERICAL ALGORITHMS GROUP, Inc.

email: naginfo@nag.com



NAG Inc, 1400 Opus Place, Suite 200, Downers Grove, IL 60515-5702, USA, Tel: +1 708 971 2337 Fax: +1 708 971 2706

NAG Ltd, Wilkinson House, Jordan Hill Road, OXFORD, OX2 8DR, UK, Tel: +44 865 511245 Fax: +44 865 310139

For More Information Write In No. 414

Reducing Ripple in a Switching Voltage Regulator

A current opposing the ripple current is injected into the filter capacitor.

Goddard Space Flight Center, Greenbelt, Maryland

Ripple voltage in the output of a switching voltage regulator can be reduced substantially by simple additional circuitry that adds little to the overall weight and size of the regulator. Heretofore, the additional filtering circuitry needed to obtain comparable reductions in ripple were typically as large and heavy as the original regulator.

Like many other power-supply circuits, a switching voltage regulator includes a low-pass output filter that effects at least a first-order reduction of ripple in that it reduces the ac component of voltage generated by switching of one or more power transistor(s). The filter includes a capacitor connected across the output terminals, in parallel with the load. The essence of the present technique is to inject, into this capacitor, a current equal in amplitude and wave shape but opposite in phase to the ripple current that already flows into this capacitor. In principle, this would reduce the net ripple current and thus the net ripple voltage to zero. In practice, the net amplitude of the ripple current

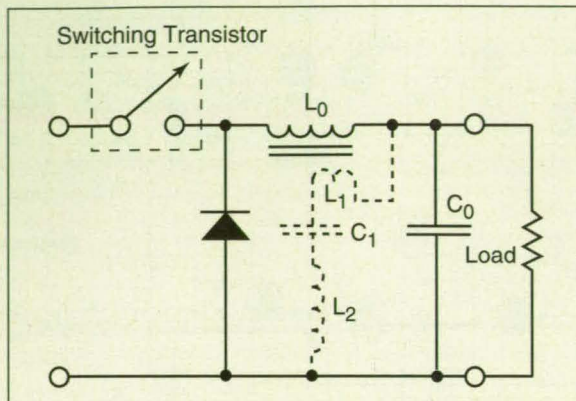

Simple Additional Circuitry that consists of relatively small components can reduce the output ripple by a factor of about 10. The additional components are indicated by the dashed lines.

can be reduced by a factor of about 10.

The figure illustrates the application of the technique to a buck regulator with a single inductor L_0 and capacitor C_0 . A small additional winding L_1 in inductor L_0 provides transformer coupling to generate the current that opposes the original ripple current. The circuit from L_1 through C_0 is completed by a small additional external

inductor L_2 and coupling capacitor C_1 .

Unlike L_0 , L_1 does not have to carry the main dc load current. Consequently, L_1 can be much smaller than L_0 . Also, provided that the effective series resistance of coupling capacitor C_1 is small, the amount of power dissipated in the low-pass filter is reduced.

This work was done by John Paulkovich and G. Ernest Rodriguez of Goddard Space Flight Center. For further information, write in 68 on the TSP Request Card. GSC-13594.

The Best. We PROMise.

UTMC promises to give you leading edge ICs for designing satellites and aerospace systems. Now we deliver again with the densest radiation-hardened PROM in the industry.

Available in 8Kx8 and 32Kx8 configurations, our new PROMs save power and space. These high performance memory devices feature fully asynchronous operation requiring no external clocks or timing strobes.

Call UTMC today to discover why our PROM is the best for your system designs. You'll love it, we promise.



**UNITED
TECHNOLOGIES
MICROELECTRONICS
CENTER**

DEDICATED TO AEROSPACE AND DEFENSE



PROM

800-645-UTMC
1575 Garden of the Gods Road
Colorado Springs, Colorado 80907

Call me, I'm interested. Write In No. 411
Please send literature. Write In No. 432

Modified Relay Switch Has Lower Resistance

Contact resistance is decreased from 25 m Ω to less than 1 m Ω .

*Lewis Research Center,
Cleveland, Ohio*

A relay switch that withstands currents of several hundred kiloamperes and potentials of several hundred volts has been modified to decrease its contact resistance. Wire braid 0.5 in. (12.7 mm) wide was added to the floating contact buttons on the armature, and two lugs were installed on the inside position of the main contacts. These modifications reduced the contact resistance from 25 m Ω to less than 1 m Ω .

This work was done by Steven W. Huston of the Rockwell International Corp. for Lewis Research Center. For further information, write in 11 on the TSP Request Card. LEW-15121.

Regulator Circuit for Bilateral Source/Load Power System

This circuit regulates the output voltage for current in either direction.

Lewis Research Center,
Cleveland, Ohio

The figure shows a circuit that regulates an output voltage, regardless of the direction of flow of output current. More specifically, it regulates the voltage at the left source or load, which can either supply power to or receive power from the right load or source, depending on the voltages and the direction of flow of current at the load/source terminals. For example, the left source/load could be a storage battery while the right load/source could be some combination of power-consuming and power-generating circuitry that produces or consumes net power in a varying amount.

The overall system can be characterized as a voltage-controlled current source with bilateral current capability. The current flowing between the two source/loads, averaged over a power-switching cycle, is made to depend on the pulse-width modulation that governs the operation of the two power-switching devices, and this pulse-width modulation is, in turn, a function of amplified current-error and voltage-error signals. The voltage error is the difference between the actual output voltage and the output-reference voltage, which is the nominal output voltage at zero current. The pulse-width modulation is varied to increase or decrease the current, as needed, to limit the excursion of output voltage from the reference value.

An additional feature of this control circuit is that the maximum current in either direction can be limited by limiting the excursion of the output voltage from the zero-current value. Thus, external current-limiting circuitry is not necessary.

This work was done by George Madden and Bruce Kimball of Space Systems/LORAL for Lewis Research Center. For further information, write in 34 on the TSP Request Card. LEW-15311.

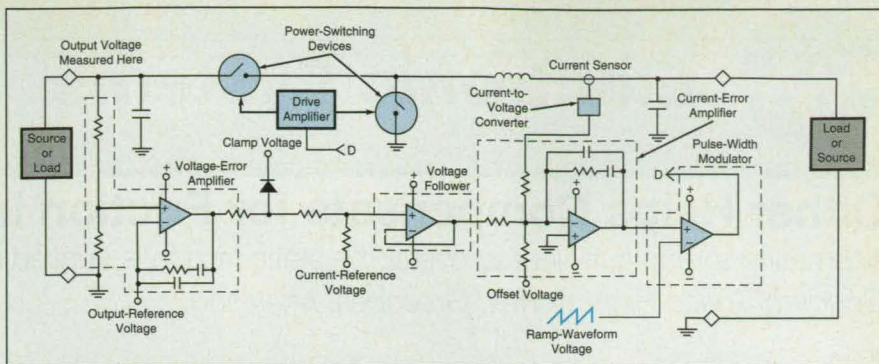

This Circuit Regulates the Output Voltage whether the current flows from the left source/load to the right load/source or vice versa.

A WORLD OF OPTIONS

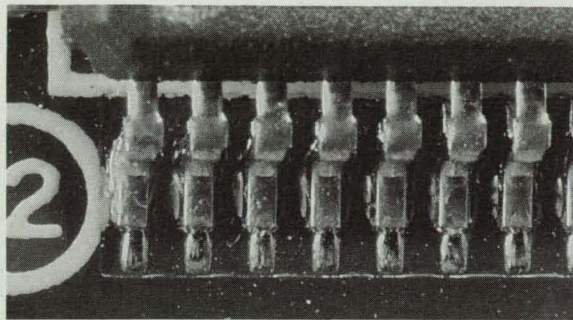

21X enlargement at 570 TV(H) lines



Elmo
ME411E
remote-head
micro CCD

For machine vision, Q.C., NDT, broadcast, laboratory and uses we haven't even thought of yet.

The Elmo ME411E, our newest remote-head B&W CCD camera, delivers 570 TV(H) lines of resolution in a 17mm diameter, one-half ounce size package, ideal for machine vision, QC, NDT, laboratory, and other limited space applications.

Elmo offers a wide variety of micro lenses including the exclusive 16mm and 25mm macro lenses that produce magnifications of nearly 200X.

Built-in features include one pulse trigger function (simultaneous random reset), restart/reset operating modes for computerized image processing; electronic shuttering; odd or even field designation; gamma changeover; field/frame modes; interlace and non-interlace modes and more.

COMPLETE LINE OF ELMO MICROS

Elmo offers three other micro sized color CCD cameras including the remarkable UN411E with a diameter of only 12mm. Discuss your needs with our experts - (never a recorded voice) - by calling: **1-800-947-ELMO**

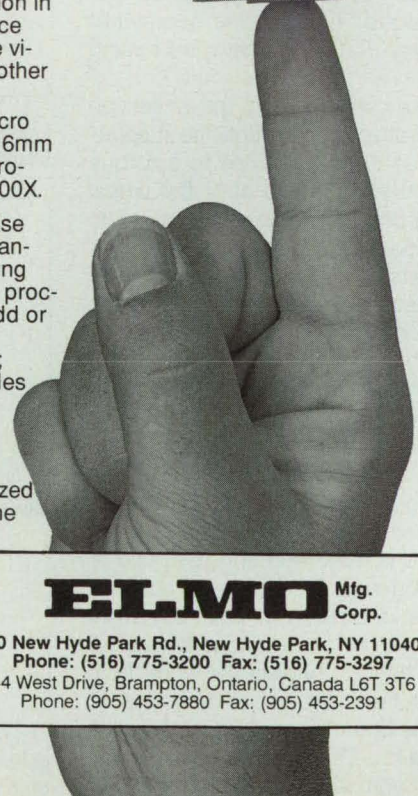
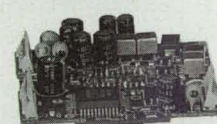

ELMO Mfg. Corp.

70 New Hyde Park Rd., New Hyde Park, NY 11040
Phone: (516) 775-3200 Fax: (516) 775-3297
44 West Drive, Brampton, Ontario, Canada L6T 3T6
Phone: (905) 453-7880 Fax: (905) 453-2391



Dither Helps Compensate for Friction in Reaction Wheel

Alternating torque sufficient to overcome static friction is applied at low speed.

Goddard Space Flight Center, Greenbelt, Maryland

A dither control and generator unit has been incorporated into a reaction-wheel attitude-control system to help compensate for error caused by friction in the reaction-wheel bearings at and near zero speed of the wheel. The reaction-wheel attitude-control system was designed primarily to maintain the desired orientation of a spacecraft but might also be useful in maintaining the desired orientation of a terrestrial antenna, optical instrument, or other device on an aircraft, ship, land vehicle, or other moving platform.

Figure 1 illustrates the principle of operation of a prior version of the system for the case of a single axis of rotation (in general, of course, there would be three axes of rotation). The output of an attitude sensor is integrated over time to generate a torque-command signal for a motor that drives the reaction wheel. As long as the wheel turns, the frictional torque in the bearings includes a fluid component that increases with speed plus a coulomb component, T_c , that is constant with speed. Once the wheel stops, it is necessary to overcome the static frictional torque, T_s , which is somewhat greater than T_c , to start the wheel turning again.

During a control action, the wheel can get stuck at zero speed until the integrated attitude error gives rise to a torque command sufficient to start the wheel turning again. While the wheel is stuck, the attitude error accumulates; when the wheel starts to turn again, the torque command that has built up can cause the wheel to overshoot the desired attitude coordinate.

To compensate partly for this effect, the prior version of the system includes an offset compensator, which performs the following computation and control action: When the speed lies within a prescribed range near zero, the value of the torque command is measured and assumed to correspond to T_c . Then when the speed of the wheel decreases to zero, the offset compensator helps to reverse the speed; that is, it helps to prevent the wheel from getting stuck at zero speed by adding, to the torque command, an offset that corresponds to $-2T_c$ according to the value assumed from the most recent measure-

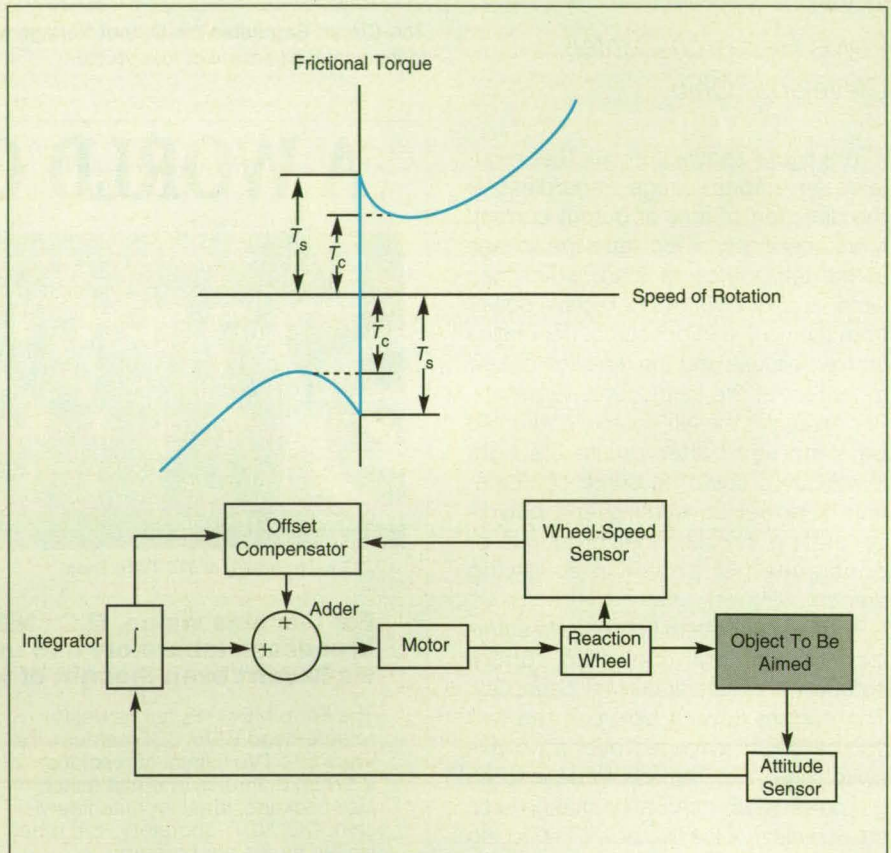

Figure 1. A **Prior Version of the Attitude-Control System** compensates approximately for the Coulomb component (T_c) of frictional torque, but not for other errors at zero speed of rotation.

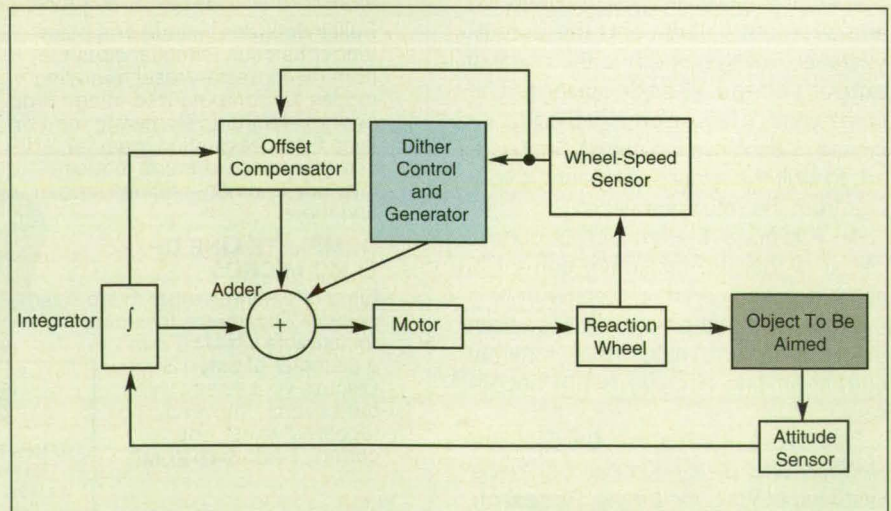

Figure 2. The **Present Version of the Attitude-Control System** includes the dither control and generator unit, which helps to suppress the remaining zero-speed errors by keeping the speed away from zero most of the time.

ment described above. However, some error remains because the offset computation does not take accurate account of all frictional and dynamical effects.

The present system (see Figure 2) is similar to the prior system except that it includes the dither control and generator unit, which helps to overcome the error that remains after the offset computation and control action. When the speed approaches zero within a prescribed value, this unit adds a torque command that alternates with a sinusoidal, sawtooth, or other symmetrical waveform at a frequen-

cy much greater than any frequency that characterizes the motion of the object, the attitude of which is to be controlled. The amplitude of this waveform is made large enough to exceed T_s and T_c under all conditions. Thus, even when the wheel gets stuck, it does not remain stuck during more than a fraction of the dither period; the amount of attitude error that can accumulate during this short time is insignificant. The small attitude error contributed by the dither signal itself does not accumulate: because of the symmetry of the dither torque command, the dithered

component of the integrated attitude error remains near zero.

This work was done by John B. Stetson, Jr., of General Electric Co. for Goddard Space Flight Center. For further information, write in 36 on the TSP Request Card.

This invention is owned by NASA, and a patent application has been filed. Inquiries concerning nonexclusive or exclusive license for its commercial development should be addressed to the Patent Counsel, Goddard Space Flight Center [see page 20]. Refer to GSC-13353.

Dual Overlapping, Weighted Preaveragers

Two modifications decrease vulnerability to interference from adjacent channels.

Lewis Research Center, Cleveland, Ohio

An improved technique to be incorporated into the digital processing of received radio signals that bear digital data reduces the bandwidth of the incoming noise when the receiver is operated over a broad range of potential signal bandwidths. In a receiver of the type in which the technique can be used, (1) the intermediate-frequency version of the signal is first passed through a filter of bandwidth sufficient to accommodate the highest potential signal rate, (2) the filtered signal is processed through an analog-to-digital converter, and then (3) the bandwidth is reduced at baseband, prior to the remainder of demodulator processing, by use of a preaveraging technique. The improved technique in question is an updated version of an older preaveraging technique; the net effect of the upgrade is to decrease the vulnerability of the receiver to interference by signals in adjacent frequency channels.

In the older preaveraging technique (see Figure 1), two accumulators that operate in parallel form the averages of digitized samples of the baseband signal at a rate N times the data-symbol rate. Each accumulator puts out an average value sample at intervals of N samples (1 symbol period), and is reset to accumulate the next N samples during the next symbol period. The accumulators dump their totals at staggered times, the outputs of one being designated as "even," the outputs of the other being designated as "odd." The even and odd streams of averages are used for different purposes in the processing of the carrier and modulating signals and the detection of data in the modulation. This technique is covered under U.S. Patent No. 5,052,027, "Programmable Noise Bandwidth Reduction by Means of Digital Averaging," September 24, 1991.

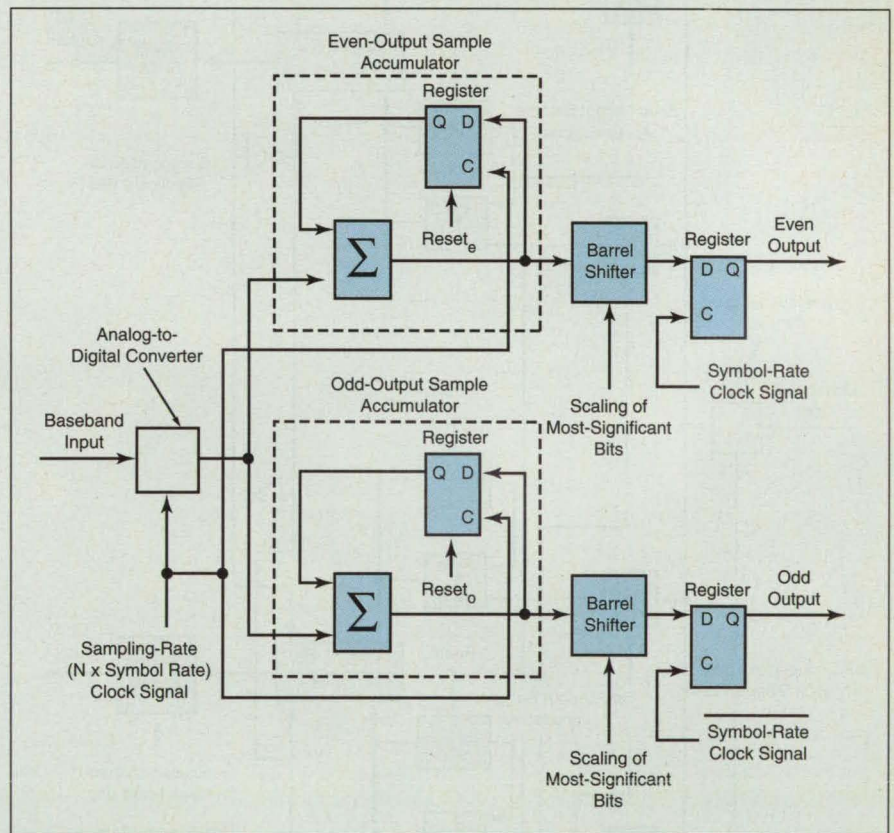

Figure 1. The **Older Preaverager** includes two accumulators that put out average sample values every N samples (1 symbol period). The output times are staggered, yielding "even" and "odd" output average streams.

The time-domain response of the older preaverager is essentially a train of impulses one symbol long, and the corresponding frequency response, $\sin x/x$, is that of a filter that does not reject adjacent frequency channels as sharply as desired. As a result, performance is degraded when a signal is present in an adjacent chan-

nel. In the improved preaveraging technique, the frequency response of the filter is made to roll off more sharply in adjacent channels, by means of two principal modifications: (1) the input samples are multiplied by an impulse-response weighting function (e.g., a raised cosine) before accumulation, and (2) the length of the averag-

ing period (impulse response aperture) is extended to 2 symbol periods.

As shown in Figure 2, the improved preaverager includes four multipliers and four accumulators. The incoming digitized samples at N times the symbol rate are multiplied by four identical impulse-response weighting functions that are staggered and overlapped at half-symbol ($N/2$) intervals. Each weighting function is associated with one of the multiplier/accumulators and repeats every 2 symbol periods. The operation of the even and odd pairs is staggered to provide even and odd out-

puts at the symbol rate. In effect, the multiplier/accumulators perform four parallel, time-staggered finite-impulse-response filtering operations. Because the averaging interval is 2 symbol periods, the bandwidth of the improved preaverager (regarded as a filter) is approximately half the symbol rate. A continuation-in-part patent application was filed for this newer technique on July 18, 1991.

This work was done by John J. Poklemba of Communications Satellite Corp. for Lewis Research Center. For further information, write in 7 on the TSP Request Card. LEW-15166.

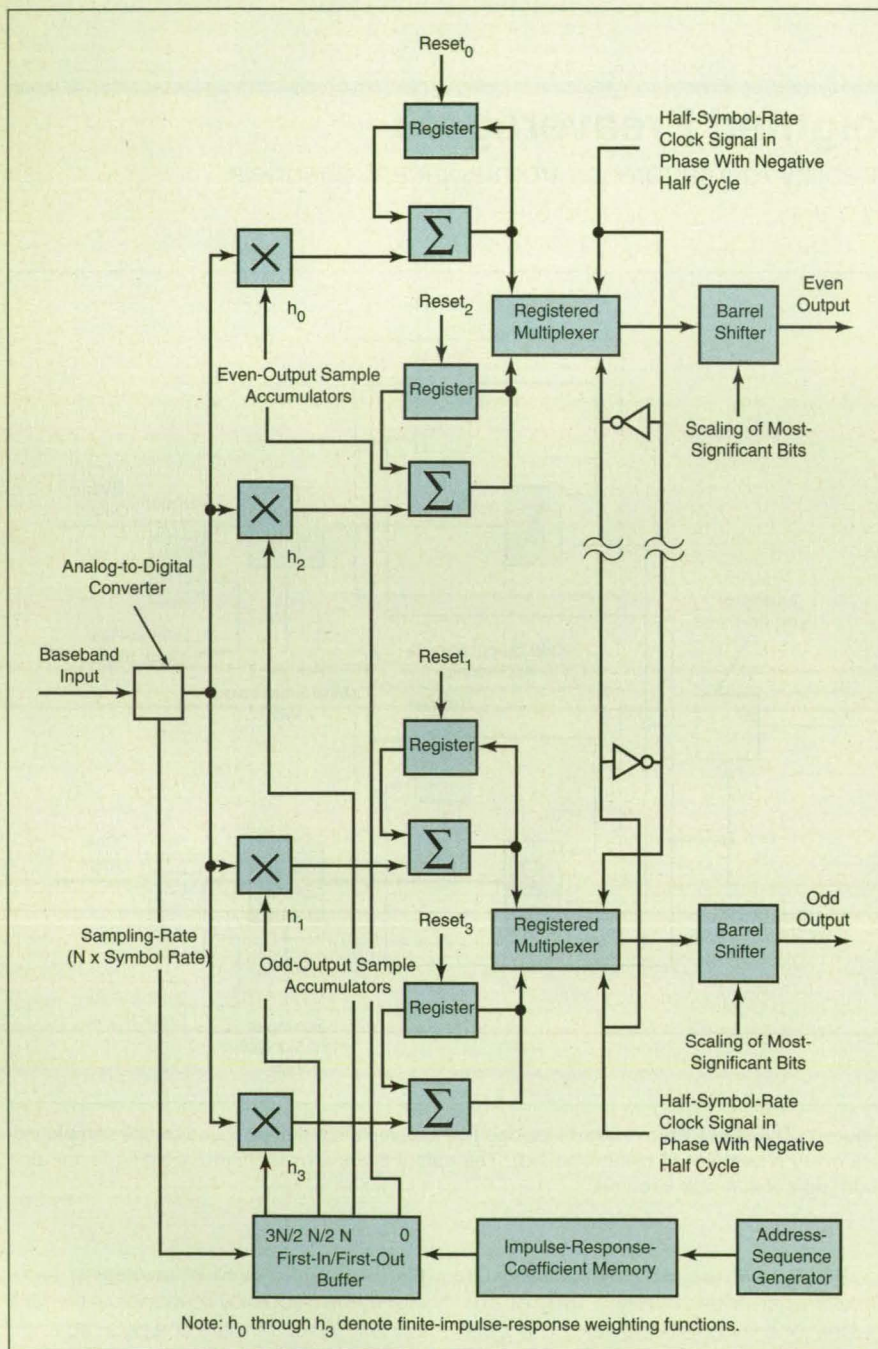

Figure 2. The **Newer Preaverager** includes four accumulators, plus a multiplier associated with each accumulator. The accumulation period is increased to $2N$ samples (2 symbol periods), and operation is staggered so that, again, even and odd averages are produced at intervals of 1 symbol period, through interlacing of the individual parallel streams that yield outputs every 2 symbols.

Robust Routing Protocol For Digital Messages

Communication in a network of computers is maintained even when links fail.

NASA's Jet Propulsion Laboratory, Pasadena, California

A refinement of a digital-message-routing protocol increases the fault tolerance of polled networks. The refinement, AbNET-3, is the latest of the generic AbNET protocols for the transmission of messages among computing nodes.

The AbNET concept was described in "Multiple-Ring Digital Communication Network" (NPO-18133), *NASA Tech Briefs*, Vol. 16, No. 11 (November 1992), page 54. In AbNET, the nodes of a network can be connected in a variety of ways that are not restricted to standard ring, mesh, or other regular configurations. With AbNET protocols, messages can be routed from any node to any or all other node(s), with no reconfiguration as the network changes.

In the basic AbNET protocol, each computer (node) that receives a message determines whether that message has been received before. If so, the computer discards the message. If not, the computer considers the message new, and retransmits the message on some or all of the communication lines available to it. Each computer in the network has more than one connection to other computers in the network. Each computer has a unique node number. When a computer originates a message, it creates a message number and sends the node number/message number pair out across all its connections.

AbNET-3 is specifically aimed at increasing the fault tolerance of the network in the broadcast mode, in which one node broadcasts a message to and receives responses from all other nodes. AbNET-3 helps to ensure that a failed connection between a pair of nodes does not ruin all communication. In AbNET-3, when a node receives a broadcast message, it responds on all lines. It then rebroadcasts the broadcast message on all lines except the line on which it received the broadcast message.

In prescribing that a node send out its response on all lines connected to it, AbNET-3 differs from previous AbNET protocols, in which a node responds only on the line on which it received the broadcast message. AbNET-3 also differs from previous AbNET protocols, in which a node simul-

taneously (1) responds on the line on which it received the broadcast message and (2) retransmits the broadcast message on all other lines connected to it.

This work was done by Maclen Marvit of Caltech for NASA's Jet Propulsion Laboratory. For further information, write in 89 on the TSP Request Card.

In accordance with Public Law 96-517, the contractor has elected to retain title to this invention. Inquiries concerning rights for its commercial use should be addressed to: William T. Callaghan; Manager; Technology Commercialization; (M/S 79-23); Jet Propulsion Laboratory; 4800 Oak Grove Drive; Pasadena, CA 91109.

Refer to NPO-18990, volume and number of this NASA Tech Briefs issue, and the page number.

Estimating Antenna-Pointing Error Using a Focal-Plane Array

Mechanical dithering to detect residual pointing error is not necessary.

NASA's Jet Propulsion Laboratory, Pasadena, California

A common method of determining residual errors in the pointing of paraboloidal-reflector microwave antennas involves constantly dithering the antenna mechanically about the estimated direction of the source. For cases where the expense of additional focal-plane collecting horns (and their amplifiers) can be justified, a new method eliminating the mechanical dithering has been developed.

The basic idea derives from the following property of a plane electromagnetic wave: the gradient of the phase of any component of either its electric or magnetic field is the propagation vector of this wave and thus yields the direction of the distant source launching it. Hence the following strategy:

1. Augment the usual single collecting horn in the focal plane of the antenna with additional horns closely packed around it.

2. Apply a two-dimensional Discrete Fourier Transform (DFT) to the complex output voltages (magnitude and phase) of the focal-plane horns. This yields samples of the field at specific points in

the aperture plane of the antenna. But these are, essentially, samples of the plane wave incident on the antenna.

3. Apply least-squares analysis to the phases of these samples to get the best least-squares estimate of the phase gradient. This determines the propagation vector of the wave and, hence, the direction of the source.

Let the unit vector pointing to the source be \mathbf{n} and let its least-squares estimate be $\hat{\mathbf{n}}$. The linear operator involved in step 3 above turns out to be so simple that it was possible to obtain a closed-

form direct solution yielding explicit formulas for $\hat{\mathbf{n}}$. Specifically, two of the components of $\hat{\mathbf{n}}$ are each determined as a very simple linear combination of the aperture-plane phases while the third component is trivially obtained from the condition that $\hat{\mathbf{n}}$ is a unit vector.

Since $\hat{\mathbf{n}}$ is based on noisy measurements (the horns' outputs), it is important to determine its reliability. This is done as follows: $\hat{\mathbf{n}}$ and $\hat{\mathbf{D}}$ are represented as points (D and \hat{D} , respectively) on a unit sphere. Having determined point \hat{D} , we look for the unit-sphere region around this point where point D is

3-D RAPID PROTOTYPING • REVERSE ENGINEERING • MODELING • ANIMATION

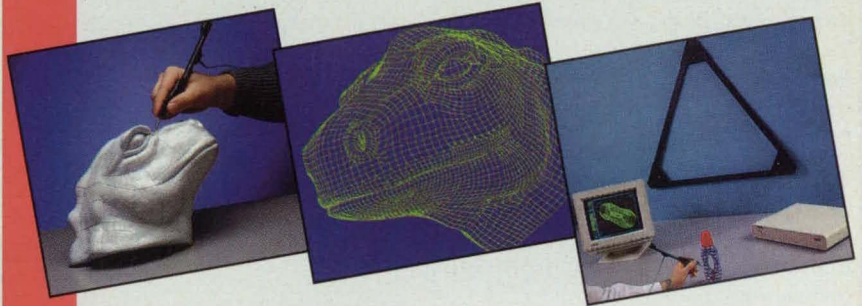

WITH

SAC's New GP-12 3-D DIGITIZER

The most versatile, easy-to-use 3-D digitizer available. Capture 3-D data in real time from any solid object within an active volume of up to 8 ft. x 8 ft. x 8 ft. (512 cubic feet). It's easy to use, just unpack — plug it in — and type "install". Place the probe on the point(s) to be entered and you're capturing X, Y, Z Cartesian coordinates.

SOFTWARE-HARDWARE COMPATIBILITY • The GP-12 works with all popular CAD/CAM packages and PC platforms, and comes equipped with its own TSR (Terminate and Stay Resident) driver. Special packages are available for modeling/animation with HyperSpace™ software from Mira Imaging and CAM programs from Cutting Edge™. These packages provide complete turnkey solutions to increase your productivity.

THE MOST FLEXIBLE 3-D DIGITIZER AVAILABLE • It's portable, works in any environment, digitizes any material, and has easy RS-232 interface. Ideal for reverse engineering . . . acquiring 3-D data from prototypes . . . defining tool paths . . . generating data for 3-D graphics, plus applications only limited by your imagination.

SEE HOW THE GP-12 CAN PUT YOU INTO THE WORLD OF 3-D. CALL TODAY.

SAC SCIENCE
ACCESSORIES
CORPORATION

2 Research Drive, P.O. Box 825
Shelton, CT 06484
(203) 925-1661 Fax (203) 929-9636

Accelerated for
Power Macintosh

HiQ

Real-World Math
for Macintosh

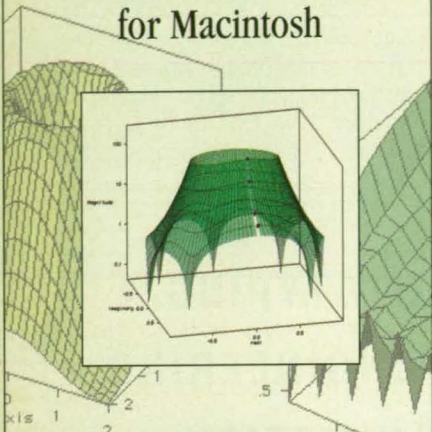

Virtual Worksheet Interface

- Interactive analysis and data visualization
- Insightful 2D and 3D graphics
- Annotation for technical reports, journals, and presentations
- Publication-quality output

Numerical Analysis Power

- More than 600 math, scientific, engineering, graphing, and utility functions
- Efficient algorithms with optimal convergence
- User-defined error tolerances

Problem Solvers

- Intuitive GUIs for solving sophisticated problems
- Automatic math code generation

HiQ-Script™

- A math language built for scientists, engineers, and mathematicians

Call for Your FREE Demo
(800) 433-3488 (U.S. and Canada)



NATIONAL INSTRUMENTS®
The Software is the Instrument™

6504 Bridge Point Parkway
Austin, TX 78730-5039
Tel: (512) 794-0100
Fax: (512) 794-8411

See us at
Sensors Expo
Booth 854

Branch Offices

- Australia 03 879 9422 • Austria 0662 435986
- Belgium 02 757 00 20 • Canada 519 622 9310
- Denmark 45 76 26 00 • Finland 90 527 2321
- France 1 48 14 24 24 • Germany 089 74 13 13
- Italy 02 48301892 • Japan 03 3788 1921
- Netherlands 03480 33466 • Norway 32 848400
- Spain 91 640 0085 • Sweden 08 730 49 70
- Switzerland 056 27 00 20 • U.K. 0635 523545

© Copyright 1994 National Instruments Corporation. All rights reserved. Product and company names listed are trademarks or trade names of their respective companies.

expected to be found with a given probability. This region is an ellipse centered at \hat{D} . The parameters of this ellipse are extracted from the eigenvalues and eigenvectors of a certain 2×2 matrix. Here, again, explicit formulas have been obtained for the elements of the matrix as functions of the aperture-plane samples.

It is obvious that, for an adopted probability value (confidence level), the size of the above ellipse increases with the noise level. The noise power, however, is auto-

matically determined by the least-squares processing and is implicitly expressed in the elements of the above 2×2 matrix. An explicit expression for this "measured" noise power has also been obtained and could serve as a constant monitor of the health of the system.

This work was done by Shalhav Zohar and Victor A. Vilnrotter of Caltech for NASA's Jet Propulsion Laboratory. For further information, write in 39 on the TSP Request Card. NPO-18739.

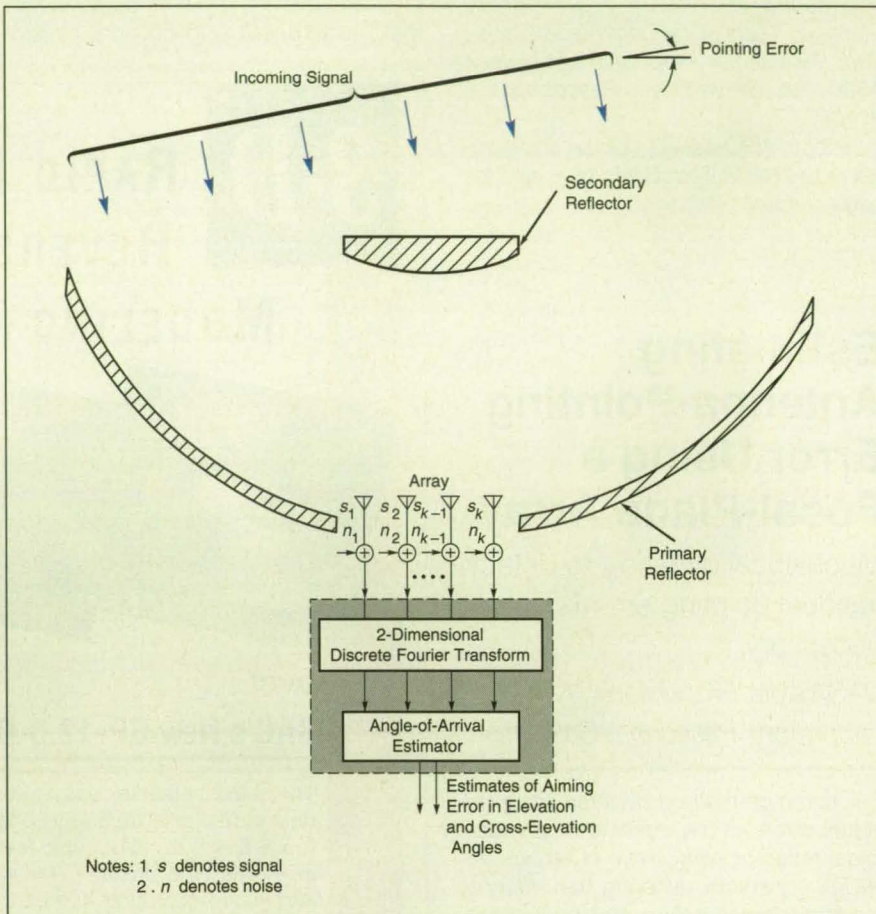

The Outputs of Multiple Receiving Feed Horns are processed to extract phase information indicative of the direction of arrival of a signal received from a distant source.

Improved Hidden-Markov-Model Method of Detecting Faults

Prior training data on faults are not necessary.
NASA's Jet Propulsion Laboratory, Pasadena, California

A method of automated, continuous monitoring to detect faults in a complicated dynamic system is based on the hidden-Markov-model (HMM) approach. This method is simpler than another, recently proposed HMM method is but retains the advantages of that method, including low susceptibility to false alarms, no need for a mathematical model of the dynamics of

the system under normal or faulty conditions, and ability to detect subtle changes in the characteristics of the monitored signals (which are time series that represent multiple sensor outputs). Examples of systems that could be monitored by use of this method include motors, turbines, and pumps that are critical in their applications; chemical-processing plants; powerplants;

The Hidden-Markov-Model Method (in both its prior version and the present improved version) is a special case of the parameter method of detecting faults: Changes in the parameters of a mathematical model fitted to input and output data are examined to detect faults.

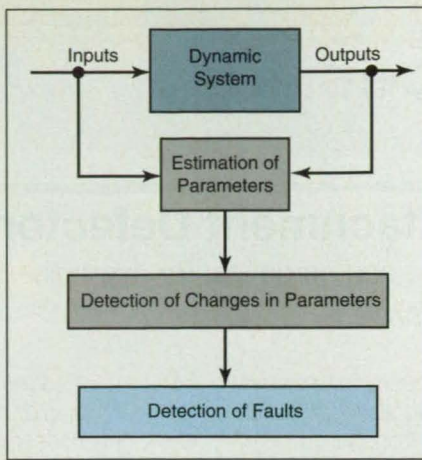

and biomedical systems.

The improved HMM method is based on four assumptions. Unlike the prior HMM method, it is not assumed that time series data on faults are available to train the hidden Markov model. Instead, it is assumed that (1) a large number of training data are available from operation under normal conditions and (2) physical constraints on possible changes in the time series are known. As in the prior method, it is also assumed that (3) the observed time-series data are stationary under both normal and faulty conditions and (4) the mean time between failures in each fault mode is known or can be estimated.

Definitions and explanations of some terms are prerequisite to a description of the improved HMM method. Let those parameters of the monitored system that are of interest at time t be denoted as the components of a vector $\theta(t)$. The parameters are typically statistical estimates of such characteristics of the time series as the means, the variances, or the coefficients of autoregression (see figure). In the HMM approach, it is by observing changes in these derived parameters that one detects changes in the underlying time series (and, hence, the system itself).

The prior HMM method involves the assumption that there are m mutually exclusive states or conditions of the system; these states are denoted ω_1 through ω_m , where ω_1 represents the normal condition and ω_2 through ω_m represent faulty conditions. Central to this method is a set of probability estimates of the form $\hat{p}(\theta(t)|\omega_i(t))$, $1 \leq i \leq m$. These estimates, in turn, are obtained by Bayes' rule from the estimates $\hat{p}(\omega_i(t)|\theta(t))$, which are learned from the training data. Inasmuch as the process is assumed to be stationary given ω , the reference to time t can be dropped at this point. This completes the definition and explanation of terms.

The improved method differs from the prior method in two ways:

1. One uses a hidden Markov model of only two states: ω_1 (normal) and ω_2 (nonnormal). For the normal state, one calculates $\hat{p}(\omega_1|\theta)$ by use of either a parametric density or a nonparametric density estimate wherein the density is fitted to the available training data.

2. For the nonnormal state, one specifies a prior density in the form of $p_{\text{prior}}(\theta|\omega_2)$.

The first change is straightforward. The second change requires that $p_{\text{prior}}(\theta|\omega_2)$ be available. In the absence of any other specific information about the behavior of θ under fault conditions, one can specify a uniform density for $p_{\text{prior}}(\theta|\omega_2)$, wherein the ranges correspond to the physical limits on the parameters. In practice, these limits are usually available. For example, the variances of signals can be bounded on the basis of the overall energy available to the system. Similarly, coefficients of autoregression must obey constraints consistent with the stationary nature of the processes. The choice of uniform density is the most appropriate when there is no prior knowledge about the parameters (other than the

ranges). Where prior knowledge is available, other prior densities can be used.

At the price of some repetition, the concept of the improved HMM method can now be clarified and summarized by describing its implementation in the following steps:

1. Set up a two-state hidden Markov model as described above.
2. Obtain the transition probabilities for the Markov portion of the model from mean-time-to-failure and mean-time-to-repair data.
3. Determine the functional form of $\hat{p}(\omega_1|\theta)$ as described above.
4. For each parameter θ_j , $1 \leq j \leq P$ (where P is the number of parameters), specify the upper and lower bounds, a_j and b_j respectively, on its possible values.
5. Specify the density $p_{\text{prior}}(\theta|\omega_2)$ as

$$p_{\text{prior}}(\theta|\omega_2) = \prod_{j=1}^J \frac{1}{b_j - a_j}$$

if there is no prior knowledge available other than the ranges of values of parameters and the density under normal conditions ($\hat{p}(\omega_1|\theta)$. If prior knowledge is available, then use this information to specify $p_{\text{prior}}(\theta|\omega_2)$.

6. Run the hidden Markov model as in the prior HMM method, in real time, but using the probability estimates described above.

This work was done by Padhraic J. Smyth of Caltech for NASA's Jet Propulsion Laboratory. For further information, write on 82 on the TSP Request Card.

This invention is owned by NASA, and a patent application has been filed. Inquiries concerning nonexclusive or exclusive license for its commercial development should be addressed to the Patent Counsel, NASA Resident Office—JPL [see page 20]. Refer to NPO-18982.

3-D At Prices That'll Jump Right Out At You!

The remarkable affordability of our 3-D gear—with patented StereoTek—is no illusion.

In fact, with a complete line that starts at \$1,195, you might say it's priced to move. Everything comes with a 30-day money back guarantee. And comfortable, light-weight, passive glasses that cost virtually nothing.

Call today for a free brochure,

800-TEK-WIDE
extension
5000.



Tektronix



Miniature Reversal Electron-Attachment Detector

The "miniREAD" could be used to detect explosives and narcotics, for example.

NASA's Jet Propulsion Laboratory, Pasadena, California

A miniature reversal electron-attachment detector (miniREAD) enables the direct injection of air or vapor at atmospheric pressure from a monitored area into a mass-spectrometric instrument to detect explosives, narcotics, or other substances, the vapors of which are suspected of being present in low concentrations. Because electron-attachment ion sources form molecular ions with less fragmentation of molecules than occurs in other electron-bombardment ion sources, they can enable the identification of the target molecules in a mass spectrometer. In comparison with the older reversal electron-attachment detector, the miniREAD is simpler in design; more rugged; and easier to build, repair, and maintain. In addition, the miniREAD will probably be more sensitive, because (1) the volume of its electron/molecule-interaction region is larger and (2) electrons and ions will be more spread out, so that space charge will constitute less of a limitation, and hence higher electron currents can be used.

In the miniREAD, electrons from a standard Bayard-Alpert ionization-gauge filament are accelerated through an outer conical or cylindrical grid electrode toward an inner cylindrical grid or porous electrode (see figure). Potentials V_c , V_g , and V_f are arranged so that electrons are accelerated from the filament toward the outer electrode, then decelerated between the outer and inner electrode. The inner electrode is biased negatively so that the trajectories of the electrons reverse just outside this electrode. The small target gas effuses through holes in this electrode. Some of the decelerated electrons become attached to the target molecules.

The resulting negative ions are then extracted, either through weak fringing fields or in a pulsed operation, toward the aperture plate, and are focused onto the entrance plane of a quadrupole mass analyzer. The target molecules are then identified in terms of their characteristic mass spectrum.

When tested with CCl_4 — which had been shown previously to simulate the

behavior of some organic explosives—ion-count rates of 100 kHz were obtained easily; it is conservatively estimated that, with higher filament power and efficient extraction of ions, rates about 1,000 times as large are possible. The miniREAD should also be capable of detecting narcotics and explosive compounds that do not contain nitrogen (e.g., peroxy compounds).

This work was done by Ara Chutjian of Caltech for NASA's Jet Propulsion Laboratory. For further information, write in 103 on the TSP Request Card.

In accordance with Public Law 96-517, the contractor has elected to retain title to this invention. Inquiries concerning rights for its commercial use should be addressed to William T. Callaghan; Manager, Technology Commercialization Office; (M/S 301-350); Jet Propulsion Laboratory; 4800 Oak Grove Drive; Pasadena, CA 91109.

Refer to NPO-18778, volume and number of this NASA Tech Briefs issue, and the page number.

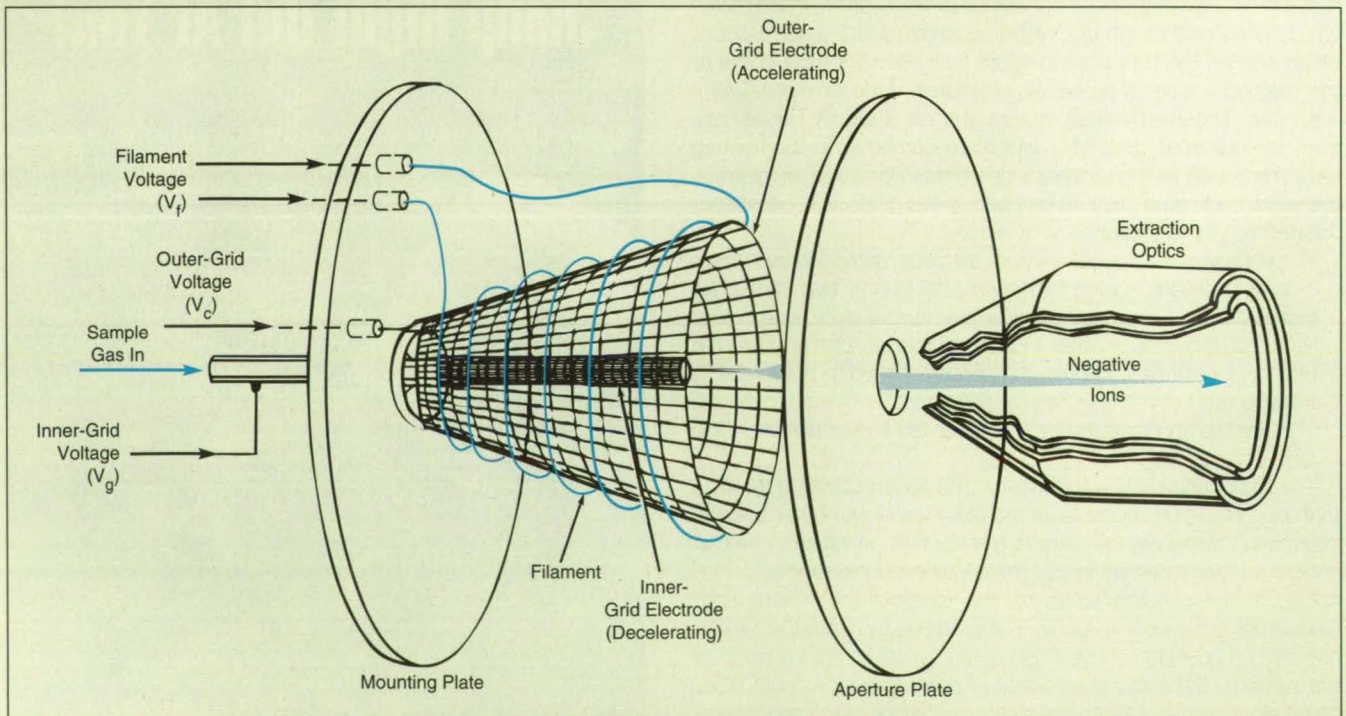

This **Miniature Reversal Electron-Attachment Ionizer** is equipped with a conical outer grid electrode and a cylindrical inner grid electrode. Alternatively, the outer electrode could be a cylindrical grid, and/or the inner electrode could be porous.

Verification and Correction of X-Ray-Spectrometer Peak Positions and Intensities

Computer control corrects for thermal shifts in the apparent positions of spectral peaks.

Lyndon B. Johnson Space Center, Houston, Texas

Experiments have shown that (1) small changes in ambient temperature can cause significant shifts in the apparent positions of peaks in x-ray spectra (see figure) during quantitative analyses by use of electron microprobes operating in conjunction with automated wavelength-dispersive x-ray spectrometers; and (2) one can correct for such shifts by using a computer subroutine to recalibrate x-ray peak positions. This correction technique obviates frequent manual recalibration of the standard peak locations and x-ray intensities of individual chemical elements, thus enabling operation of unattended instruments, as in overnight collection of data, and freeing analysts to spend more time interpreting data.

In operation for the experiments, an electron microprobe was programmed to perform 200 analyses of a standard specimen using three wavelength-dispersive x-ray spectrometers. The original analytical software was modified to verify x-ray peak positions before each analysis, as well as to record the shifts in the apparent positions of the spectral peaks.

Initially a microprocessor "get-element" function was used to move the spectrometers to the theoretical position of a spectral peak of a given element to verify that the peaks could be observed at those positions. Next, a microprocessor "peak" function was used to locate the true position of the peak for each spectrometer. The difference between the true and the theoretical position of each peak for each spectrometer was recorded in a file. Finally, a microprocessor "set-motor-position" function was used to correct the spectrometer positions (by use of drive motors) for the subsequent analysis. In each case in which the spectral peak was not insufficiently intense enough to enable a valid determination of its apparent position on any spectrometer, a discriminatory algorithm prevented the resetting of the position of that spectrometer.

The following conclusions (among others) were drawn from the results of the experiments:

- A change of 3 °F in the ambient temperature fluctuation caused the apparent positions of peaks to change by about 20 increments of position. According to estimates based on the shapes of the peaks such a shift would reduce the apparent intensities of the

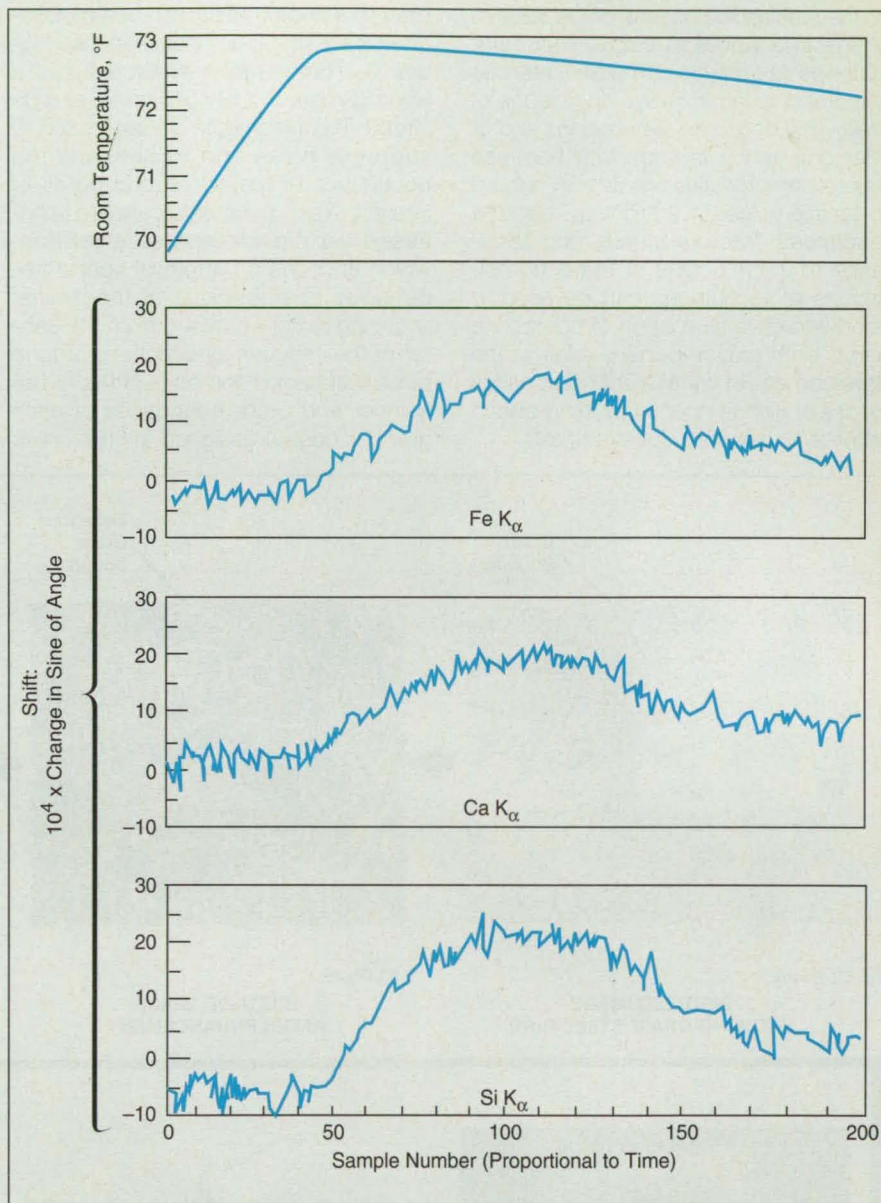

The Shifts in the Apparent Positions of Several K_α Peaks are associated with the change in the ambient temperature. Note that the changes in the positions lag behind the change in temperature. The total time interval for this figure is 15 h.

Ca, Fe, and Si K_α peaks by as much as 16 percent, 10 percent, and 26 percent, respectively.

- Verification and correction of the peak positions prior to each analysis kept the intensities of the peaks generally within 1 percent of the original intensities, even with significant changes in the positions of the apparent peaks during analytical sessions.
- Verification and correction of the

peak positions for some spectral peaks also helped to correct for drifts in other peaks (from other elements) for which verifications were not performed.

This work was done by Gordon A. McKay of Johnson Space Center and Shyue-Rong Vincent Yang and Jerry H. Wagstaff of Lockheed Engineering and Sciences Co. For further information, write in 71 on the TSP Request Card. MSC-22127.

Use of Video in Microscopic and Ultrasonic Inspection

Tone-pulse encoding and precision acoustic imaging yield grain- and pore-size distributions.
 Lewis Research Center, Cleveland, Ohio

Two combinations of video and image-data-processing techniques yield data on the spatial distributions of the sizes of grains and pores in such composite materials as ceramic or metallic matrices containing ceramic fibers. Knowledge of grain- and pore-size distributions and of fiber orientation is important because these characteristics are directly related to tensile strength, hardness, fracture toughness, fracture stress, and resistance to impact. One of these combinations of techniques can be used in nondestructive evaluation of composite parts; both play important roles in the development of lightweight composites for use at high temperatures in advanced engines and aircraft, for example.

The first combination of techniques, known as tone-pulse encoding, is applied to a photomicrograph of a metallographically prepared specimen (see Figure 1). The image is projected into a video camera of 512×512 pixels and digitized. The image data are processed to suppress noise and to enhance the boundaries of the grains and pores of interest. Next, the image data are processed via the tone-pulse algorithm, which encodes a pattern of spatial frequencies characteristic of the grains: scanning radially outward from the center of the image in all directions, a tone pulse that begins and ends at the radially inner and outer boundaries of each grain or pore is assigned to that grain.

The width of each pulse equals the width of the grain or pore, and the amplitude of the pulse is inversely proportional to the width of the grain.

The encoded image is processed with the help of Fourier transforms. The net results of the processing are (1) data on $P(r, \phi)$, the density of components of length r oriented at angle ϕ , and (2) a picture of the mean grain or pore shape computed from $P(r, \phi)$.

The second combination of techniques, known as precision acoustic imaging, incorporates precision acoustic scanning, which has been in use for several years. The principal application is in making images of variations in porosity produced during sintering. In this

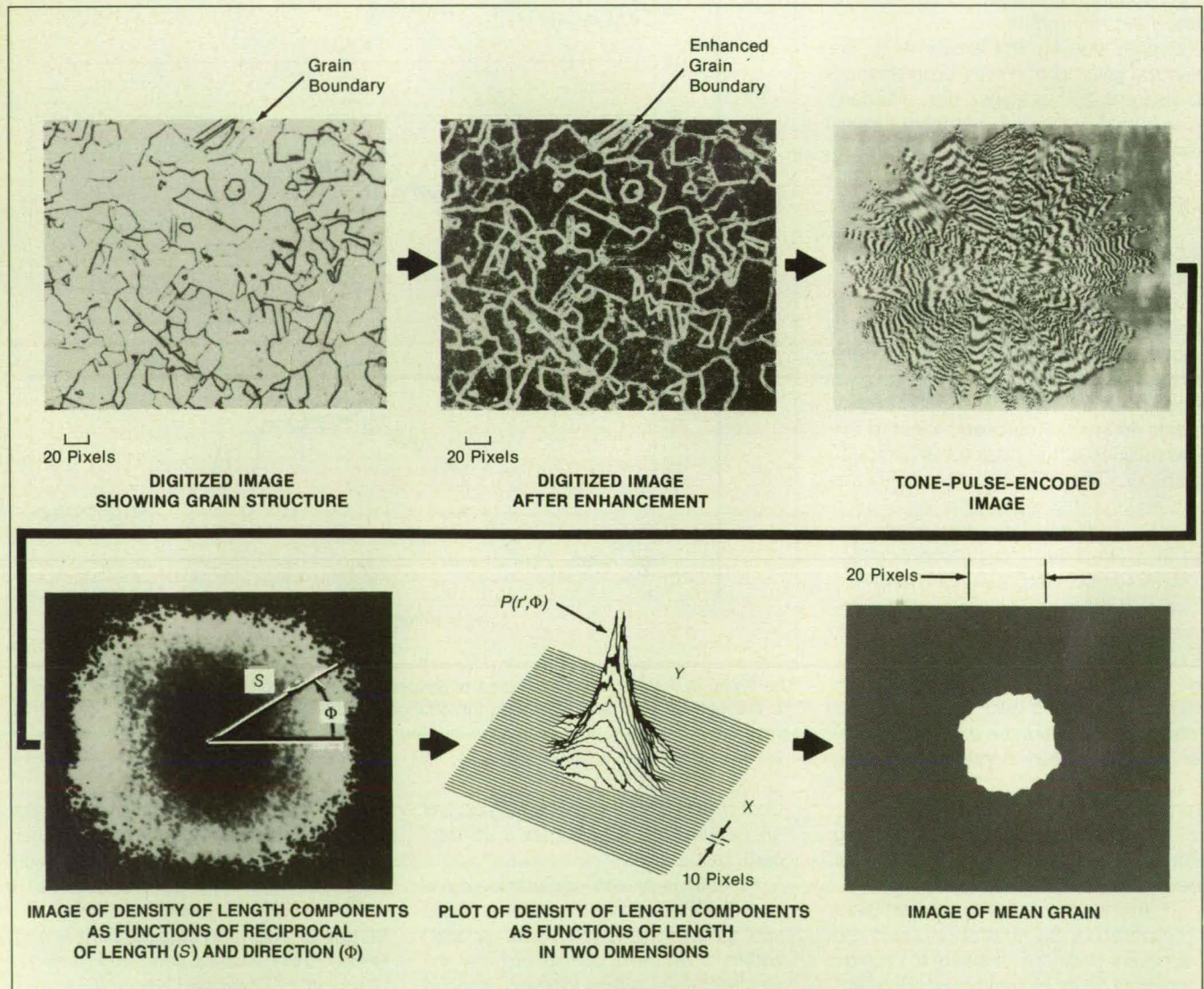

Figure 1. The **Digitized Image** of a metallographically prepared specimen is processed to obtain quantitative data on the sizes and shapes of grains and to produce an image of a "mean" grain — one that has a representative size and shape.

combination of techniques, an ultrasonic transducer is scanned over the surface of a specimen (see Figure 2). After collection and subsequent Fourier analysis of the appropriate waveforms, an accurate determination of acoustic velocity and attenuation can be made. This is done at different positions on the specimen in an organized array. The resultant data can be displayed on a video system as maps of velocity and attenuation.

The frequency dependence of the attenuation is related to the sizes of subsurface flaws or pores, the state of recrystallization (in the case of metal), and the mean size of grains. The video system provides easy access to this information as well as to information on diffraction and refraction like that described in the preceding article, "Ultrasonic Inspection With Angular-Power-Spectrum Scanning" (LEW-15386).

This work was done by Edward R. Generazio and Don J. Roth of **Lewis Research Center**. Further information may be found in NASA TM-102491 [N90-22801], "Recent Advances in Nondestructive Evaluation Made Possible by Novel Uses of Video Systems."

Copies may be purchased [prepayment required] from the National Technical Information Service, Springfield, Virginia 22161, Telephone No. (703) 487-4650. Rush orders may be placed for an extra fee by calling (800) 336-4700. LEW-15383.

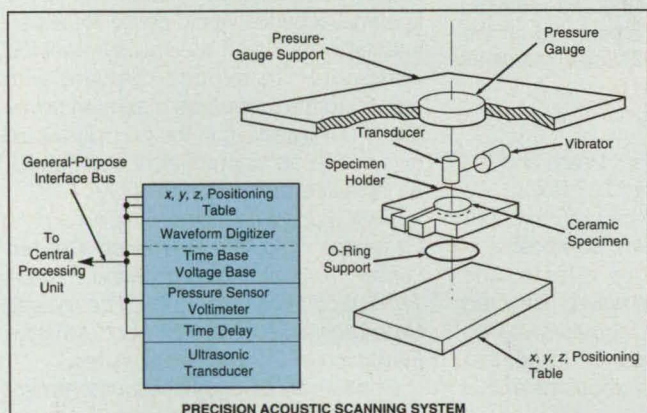

PRECISION ACOUSTIC SCANNING SYSTEM

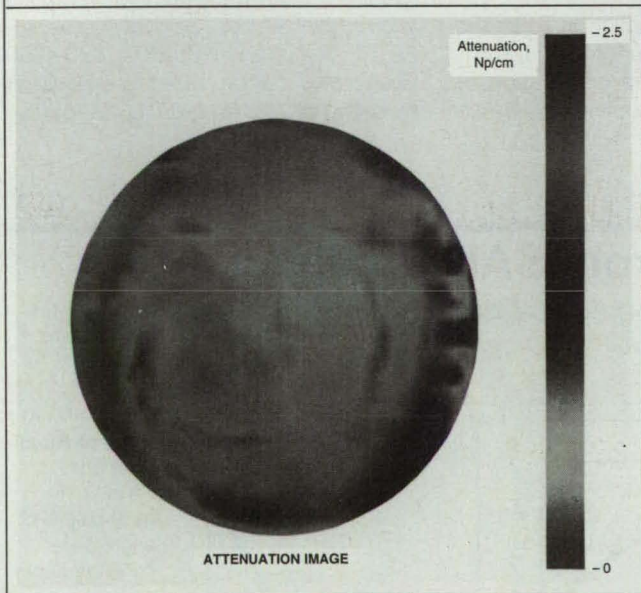

ATTENUATION IMAGE

Figure 2. Precision Acoustic Scanning, combined with video and digital techniques, can yield video images like this one, which shows the cloudlike distribution of porosity inside a silicon carbide disk 4 cm in diameter.

Find out how 3M
can keep your harness
out of hot water.
Call (800) 328-0016 ext.57.

3M Electrical Specialties Division

3M Innovation

For More Information Write In No. 402

Ultrasonic Inspection With Angular-Power-Spectrum Scanning

Superposed diffraction patterns give clues to internal structural features of ceramic composites. *Lewis Research Center, Cleveland, Ohio*

Angular-power-spectrum scanning (APSS) is an emerging technique of ultrasonic nondestructive inspection of the interiors of ceramic fiber/matrix composite panels. The principal advantage of APSS is that, unlike x-radiography and prior ultrasonic techniques, it can reveal subtle distributions of microstructural features; e.g., variations in densities of micropores or regions in which fibers and matrices are poorly bonded to each other. Potential applications include the development and characterization of composite-material components of large structures, such as buildings and bridges; determination of quality and detection of damage in fiberglass hulls, surfboards, ladders, and scaffolds; and development of porous prosthetic skins and complicated "smart" materials.

The underlying concept and measurement procedure of APSS are similar to optical diffraction measurements as well as the measurements that are made to determine the radiation patterns of radio antennas. In each of these cases, one extracts information about a radiating or scattering (reflecting, diffracting, and/or refracting) source from the angular distribution of the density of scattered power measured at a specified distance from the source.

In this case, an ultrasonic transmitter aims an acoustic beam

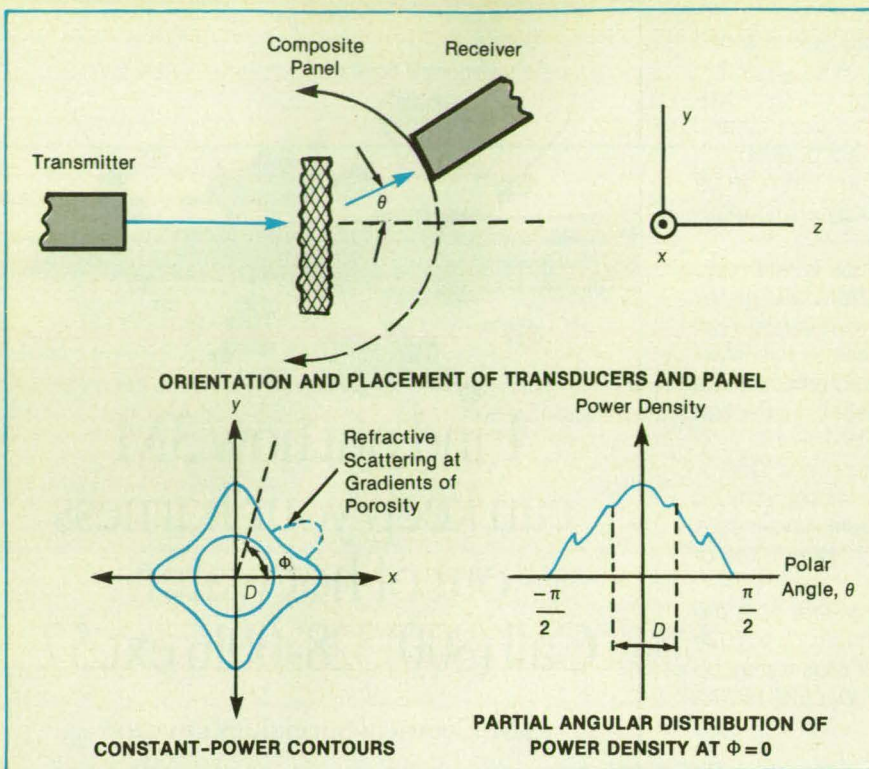

The **Angular Distribution of the Power Density** of ultrasound diffracted and refracted from a panel is measured by scanning the receiver over a hemisphere centered on the inspected spot. The measurements are indicative of internal structural features of the panel at that spot.

(typical frequency 10 to 50 MHz) at a spot on the panel to be inspected, and a receiver remains aimed radially toward the spot while it is scanned over a hemisphere to measure the angular distribution of the density of scattered power (see figure). An array of transducers may also be used to measure this scattered power. A through transmission configuration is shown in the figure. A single sided backscatter configuration may also be used. To inspect the whole panel, it is necessary to repeat this angular scan at many overlapping spots covering the entire surface. The interac-

tions between the incident beam and the panel can be summarized as follows:

- Micropores are distributed throughout a typical fiber/matrix composite; in the absence of other effects, the superposition of sound waves diffracted from the micropores should yield an angular distribution of power density that is circularly symmetrical about the axis of the beam.
- The velocity of sound in a porous material is proportional to its density, which varies with the distribution of micropores. Therefore, ultrasonic waves

are refracted at gradients in the density of micropores. The resulting angular distribution of power density is asymmetrical.

• The interaction between ultrasound and parallel fibers is analogous to the diffraction of light through slits; the strength of the interaction increases where fibers are poorly bonded to the matrix. The resulting power-density pattern is symmetrical about the projection of the axes of the fibers onto a plane perpendicular to the axis of the incident beam.

The lower part of the figure gives an example of the angular distribution of power density for a laminated composite panel in which fibers are oriented along the x axis in half the layers and along the y axis in the other layers. The constant-power-density contours should be four-fold symmetrical about the axis of the incident beam (z axis). A uniform increase in porosity throughout the panel would increase the diameter, D , of the circularly symmetrical component of the plot of power density as a function of the polar angle, ϕ . A uniform weakening of the fiber/matrix bonds would cause the experimentally measured fourfold-symmetrical component to expand outward with respect to the normalized maximum power at $\theta = 0$. A gradient in the porosity would give rise to an asymmetrical component, as indicated by the dotted curve.

This work was done by Edward R. Generazio of Lewis Research Center. Further information, may be found in NASA TM-102561 [N90-23754], "Theory and Experimental Technique for Nondestructive Evaluation of Ceramic Composites."

Copies may be purchased [prepayment required] from the National Technical Information Service, Springfield, Virginia 22161, Telephone No. (703) 487-4650. Rush orders may be placed for an extra fee by calling (800) 336-4700. LEW-15386.

Estimating Elevation Angles From SAR Crosstalk

A monopulselike scheme yields low-resolution topographical data.

NASA's Jet Propulsion Laboratory, Pasadena, California

A scheme for processing polarimetric synthetic-aperture-radar (SAR) image data yields estimates of the elevation angles along the radar beam to target resolution cells. By use of the estimated elevation angles, the measured distances along the radar beam to the targets (slant ranges), and the measured altitude of the aircraft carrying the SAR equipment, one can estimate the height of the target terrain in

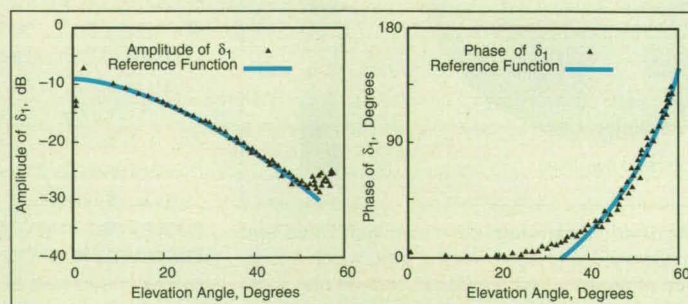

Figure 1. These **Plots of Amplitude and Phase of δ_1** as functions of angle were computed from an SAR scan of a rain forest in Belize.

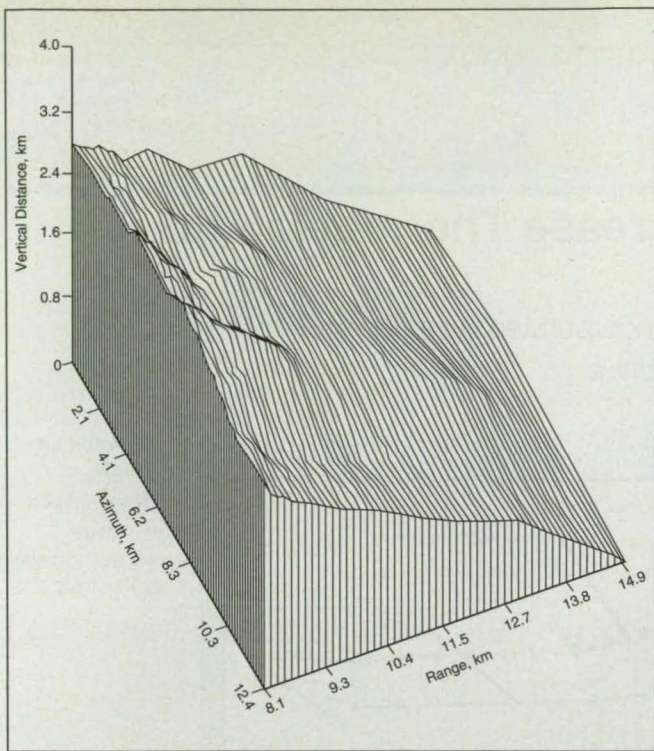

Figure 2. This **Crude Terrain-Height Plot** was generated partly from crosstalk data according to the scheme described in the text.

each resolution cell. As explained below, each resolution cell consists of an $n \times n$ (typically, 8×8) group of contiguous pixels. Thus, this scheme yields data from which one can construct a low-resolution topographical map of the terrain.

The scheme for estimating elevation angles is based on the observation that the relative amplitude and phase of crosstalk between the horizontal and vertical polarization channels of the transmitting and receiving equipment is a property of the equipment itself. As such, the crosstalk can be represented by two complex parameters (δ_1 and δ_2) that are independent of the radar backscatter signal and depend only on the angular deviation of the line of sight to the target from the nominal main axis of the radar beam. Provided that some customary simplifying assumptions are satisfied, δ_1 and δ_2 are two of six unknowns that can be computed by iterative solution of six equations. The input data for these equations are sums or averages, over the resolution cell, of products of polarimetric backscatter measurements expressed in complex-number form.

Data that show the dependence of δ_1 and δ_2 on elevation angle are computed from calibration SAR scans that are performed at a known altitude over known, preferably flat terrain. Polynomial reference curves are fitted to these data. Figure 1 presents an example of two such reference curves. One or more of the reference curves can be used to generate a lookup table in electronic memory, which can thereafter be used to determine the elevation angles of resolution cells in SAR images from the values of δ_1 and δ_2 computed from the SAR data from those cells.

Figure 2 shows a crude terrain-height map generated with the help of this scheme from an SAR scan of part of Death Valley, California. The terrain includes a mountainous area that slopes down to alluvial fans. This low-resolution map does not show the high-spatial-frequency variations in the altitude of the terrain in the mountainous area, but it does conform fairly well to the large-scale relief of the terrain.

This work was done by Anthony Freeman of Caltech for NASA's Jet Propulsion Laboratory. For further information, write in 63 on the TSP Request Card. NPO-18743.

Kynar® heat-shrink tubing is flame retardant and clear for easy inspection. It is perfect for high-temp work.

Find out how to beat the heat with 3M.

Call (800)328-0016 ext.73.

3M Electrical Specialties Division

3M Innovation

For More Information Write In No. 403

Kynar is a registered trademark of Pennwalt Corp.

Dipsticks for Clear Liquids

One side is light; the other is dark.

Lewis Research Center, Cleveland, Ohio

An improved dipstick (see figure) is partly blackened on one side to enhance the visibility of an adhering clear liquid. This improvement makes it easier to measure the level of a clear liquid in an application in which a sight glass is impractical: when using a lightly colored dipstick, it is difficult to measure the level of a clear or nearly clear liquid (such as new oil), particularly when the dipstick is coated by only a thin film of the liquid. The front side of the dipstick is left a light color (e.g., bare metal is left uncolored) to provide a good surface for measuring the level of a dark liquid (for example, used oil).

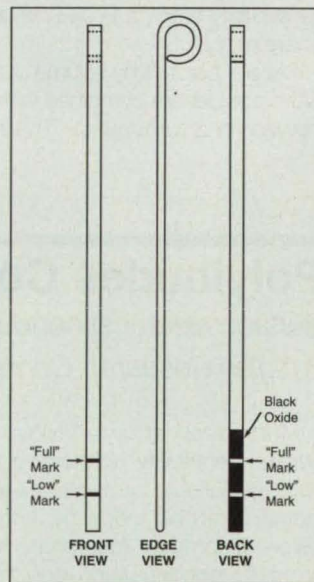

This work was done by George S. Thomas of Rockwell International Corp. for Lewis Research Center. No further documentation is available. LEW-15316.

An **Improved Dipstick** is lightly colored on one side (for measuring the level of a dark liquid) and dark on the other side for measuring the level of a clear or lightly colored liquid.



Phonon-Scattering Centers Increase Thermoelectric Efficiency

Small particles that reduce thermal conductivity are incorporated via a powdermaking process. NASA's Jet Propulsion Laboratory, Pasadena, California

Small, electrically inert particles of Si_3N_4 or BN that serve as phonon-scattering centers can be added to the thermoelectric p-doped material $\text{Si}_{0.8}\text{Ge}_{0.2}$. These particles reduce the thermal conductivity of the material (see figure), thereby increasing its thermoelectric efficiency. The particles are incorporated via a powdermaking and powder-consolidation process: by use of spark erosion, the constituent materials are converted to powders, which are then mixed and hot-pressed to form the Si_3N_4 or BN particles in the $\text{Si}_{0.8}\text{Ge}_{0.2}$ matrix thermoelectric material. These particles reduce the thermal conductivity of the resulting composite material to as much as 30 percent below that of the doped $\text{Si}_{0.8}\text{Ge}_{0.2}$, the exact amount depending on temperature.

In the spark-erosion apparatus, an electrode of doped $\text{Si}_{0.8}\text{Ge}_{0.2}$ is eroded in flowing argon by use of a 17,000-V, 100-A, 240-Hz power supply. The erosion process forms an ultrafine powder of doped $\text{Si}_{0.8}\text{Ge}_{0.2}$ particles 40 to 200 Å in diameter. The powder is collected in a glove box. A powder of BN or Si_3N_4 particles is formed by similarly eroding B or Si in an atmosphere of N_2 .

Several percent by volume of the BN or Si_3N_4 powder are combined with the SiGe powder in a turbopump. The mixture is

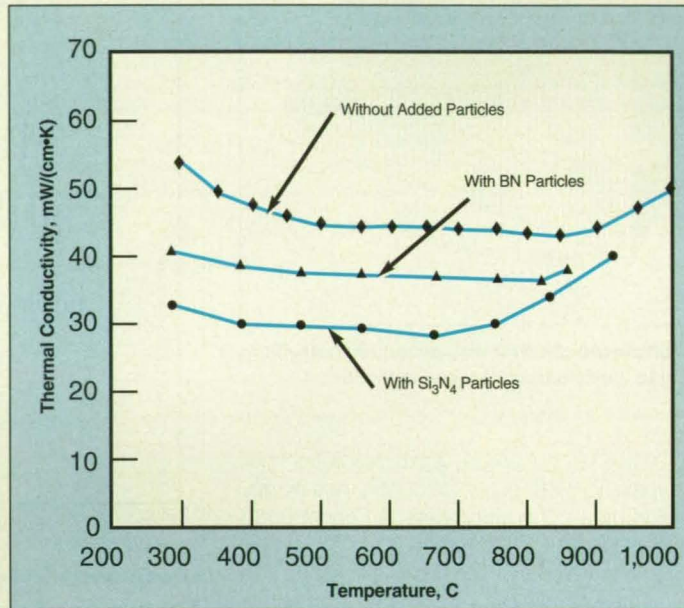

The Addition of Si_3N_4 or BN to p-doped $\text{Si}_{0.8}\text{Ge}_{0.2}$ reduces thermal conductivity.

hot-pressed, typically at a temperature of 1,525 K and pressure of 20 kpsi (138 MPa) for 13 h (in the case of BN) into a fully dense thermoelectric material. In both cases, hot-pressed material can be heat-treated further (e.g., 1,525 K for 50 h) to make the grains grow from submicron to submicron size.

This work was done by Jan Vandersande and Jean-Pierre Fleurial of Caltech and John Beatty and John Rolfe of the ThermoTrex for NASA's Jet Propulsion Laboratory.

For further information, write in 31 on the TSP Request Card. NPO-19023.

Polyimides Containing Silver Trifluoroacetylacetonate

Surface electrical conductivities as large as $4.5 \Omega^{-1}$ have been achieved.

Langle Research Center, Hampton, Virginia

Mechanically strong, flexible, thermally stable, electrically conductive films and coatings suitable for use in the electronics industry can be made by incorporating silver trifluoroacetylacetonate into linear aromatic condensation polyimides. Experimental films of this type have exhibited surface electrical conductivities of 1.7×10^{-3} to $4.5 \Omega^{-1}$.

With the exception of the addition of silver trifluoroacetylacetonate, a conductive

polymer of this type is synthesized in the manner of a typical polyimide. This involves (1) reacting an aromatic diamine with an equimolar amount of aromatic dianhydride (or optionally in slightly unequal amounts with a small amount of an end-capping agent) at room temperature in a solvent to obtain a polyamic acid resin, (2) casting the resin as a film or applying it as a coating, and (3) thermally curing the film or coating at a temperature between

250 and 300°C to convert it to the final polyimide form. The silver trifluoroacetylacetonate can be added to the reaction mixture or to the intermediate product polyamic acid resin.

The aromatic dianhydride used to make each of the experimental conductive polyimides was either 3,3',4,4'-benzophenone tetracarboxylic dianhydride (BTDA) or pyromellitic dianhydride (PMDA); the diamine in each case was

either 4,4'-oxydianiline (4,4'-ODA) or 2,2[4-(4-aminophenoxy)phenyl]hexafluoropropane (4-BDAF); and the solvent in each case was N,N-dimethylacetamide (DMAc). Other dianhydrides that might also prove suitable include 4,4'-oxydiphthalic anhydride (ODPA), 4,4'-bis(3,4-dicarboxyphenoxy) diphenylsulfide dianhydride (BDSA), 2,2'-bis(3,4-dicarboxyphenyl) hexafluoropropane dianhydride (BFDA), 1,4-bis(3,4-dicarboxyphenoxy) benzene dianhydride, and 3,4,3'4'-biphenyl tetracarboxylic dianhydride. Other suitable diamines might include any isomer of oxydianiline,

diaminobenzophenone, diaminodiphenylmethane, phenylenediamine, diaminodiphenylsulfone, and bis(amino-phenoxy)phenyl hexafluoropropane.

In the experimental films, the most successful combinations of flexibility and conductivity were obtained by use of 1:1, 1:1.74, and 1:2 mole ratios of silver trifluoroacetylacetonate per polyimide repeat unit. Other concentrations of silver trifluoroacetylacetonate could be used with different heat-treatment schedules to obtain conductive silver-impregnated films.

This work was done by Diane M. Stoakley and Anne K. St. Clair of Langley Research Center, James D. Rancourt and Larry T. Taylor of Virginia Polytechnic Institute and State University, and Maggie L. Caplan of Lockheed Engineering & Sciences Co.

No further documentation is available.

Inquiries concerning rights for the commercial use of this invention should be addressed to the Patent Counsel, Langley Research Center [see page 20]. Refer to LAR-15052.

Deposition of Cubic BN on Diamond Interlayers

Cubic boron nitride films would be grown for use where diamond films are unsuitable.

NASA's Jet Propulsion Laboratory, Pasadena, California

Thin films of polycrystalline, pure, cubic boron nitride (c-BN) would be formed on various substrates, according to a proposal, by chemical vapor deposition onto interlayers of polycrystalline diamond (see figure). Substrate materials could include metals, semiconductors, and insulators. Typical substrates would include metal-cutting tools: polycrystalline c-BN coats would be advantageous for cutting ferrous materials and for use in highly oxidizing environments — applications in which diamond coats would tend to dissolve in the iron or be oxidized, respectively.

Cubic BN, which has a crystalline structure like that of zinc blende, offers advantageous properties similar to those of diamond: it is chemically inert, thermally conducting, and electrically insulating, and, after diamond, it is the hardest known material. However, recent attempts to deposit thin films of c-BN from chemical vapors at pressures low enough to be practical have met with limited success. The c-BN contents of BN films deposited experimentally at low pressures have been estimated to be 10 percent at most. This has been attributed to the fact that c-BN is thermodynamically metastable under normal atmospheric conditions. Heretofore, neither the use of auxiliary gas (e.g., atomic hydrogen) during deposition nor the epitaxial forces exerted by substrates with matched crystalline lattices could be relied upon to stabilize the metastable c-BN surfaces.

However, the combination of (1) the close match between the crystalline lattices of diamond (lattice constant = 3.567 Å) and c-BN (lattice constant = 3.616 Å) and (2) the compatibility of the chemistries of these two materials is ex-

pected to enable the chemical vapor deposition of c-BN on an interlayer of polycrystalline diamond film, according to the proposal. Diamond has been grown on single-crystal c-BN that was synthesized at high pressure, and techniques for the growth of strongly adherent diamond films with different microstructures on metals, semiconductors, and insulators are well established.

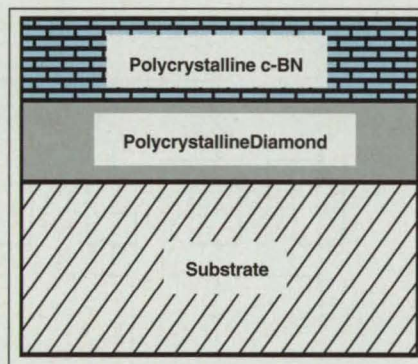

Polycrystalline Cubic Boron Nitride would be deposited on a substrate by use of a polycrystalline diamond interlayer.

As an example of the proposed approach, a popular tool-bit material that consists of 6 percent cobalt in tungsten carbide would be coated with c-BN in the following process: First, cobalt would be etched away from the surface by use of nitric acid. (It would be necessary to do this because cobalt on the surface would tend to catalyze the formation of soot during deposition). The etched surface would be rubbed with diamond powder of submicron particle size to promote nucleation of diamond. A thin buffer layer of amorphous silicon would then be deposited to promote adhesion of the diamond.

Next, the diamond interlayer would be deposited from a mixture of 0.5 to 2 percent methane in hydrogen at a rate of flow of 100 to 500 standard cm³/min, a temperature of 600 to 1,000 °C, a pressure of 40 to 100 torr (about 5 to 13 kPa), a filament temperature of 2,000 K (if a hot filament is used to assist growth), and a power of 400 to 700 W at a frequency of 2.45 GHz (for microwave plasma growth). Finally, c-BN would be deposited on the diamond film by, for example, chemical vapor deposition, enhanced by electron-cyclotron-resonance microwave plasma (400 to 700 W at 2.45 GHz), from a mixture of 0.5 to 1.5 percent B₂H₆ in nitrogen at a rate of flow of 50 to 100 standard cm³/min, a temperature of 400 to 700 °C, and a pressure of 0.5 to 10 mtorr (about 0.07 to 1.3 Pa), and a microwave power of 400 to 700 W. A bombardment by ions at low energy may be needed to promote the nucleation and growth of the c-BN: such bombardment could be accomplished easily by use of dc or radio-frequency bias.

This work was done by Tiong P. Ong and Yuh-Han Shing of Caltech for NASA's Jet Propulsion Laboratory. For further information, write in 74 on the TSP Request Card.

In accordance with Public Law 96-517, the contractor has elected to retain title to this invention. Inquiries concerning rights for its commercial use should be addressed to: William T. Callaghan; Manager, Technology Commercialization; (M/S 79-23); Jet Propulsion Laboratory; 4800 Oak Grove Drive; Pasadena, CA 91109.

Refer to NPO-18847, volume and number of this NASA Tech Briefs issue, and the page number.

Iridium-Coated Rhenium Combustion Chamber

Operating temperature is increased to 2,200 °C.

Lewis Research Center, Cleveland, Ohio

An iridium-coated rhenium combustion chamber withstands operating temperatures up to 2,200 °C. The chamber is designed to replace an older silicide-coated combustion chamber in a small rocket engine. The older chamber, which represented the state of the art at the time of its development, could operate at a maximum temperature of about 1,400 °C with film cooling. The newer chamber makes it possible to take advantage of a uniform stoichiometric combustion process that is hotter and more efficient than the older combustion process is. Modified versions of the newer chamber could be designed

for use on Earth in gas turbines, ramjets, and scramjets.

Iridium and rhenium have the requisite high melting temperatures. However, rhenium is so hard and brittle that it cannot be drawn to desired shapes, and it is very difficult to machine it. The iridium-coated rhenium combustion chamber is fabricated in net shape by chemical-vapor deposition (even complicated net shapes can be produced by this technique).

The iridium-coated rhenium combustion chamber was demonstrated in 2 h of operation as a thruster and 17 h of operation at temperatures between 2,000 °C

and 2,260 °C, including 10^5 starts. The new, higher-efficiency combustion process made possible by the iridium-coated rhenium chamber requires less fuel to produce a given performance: For example, the estimated reduction in the mass of propellant needed for a contemplated spacecraft mission to an asteroid would be 600 kg.

This work was done by Steven J. Schneider of Lewis Research Center, Robert H. Tuffias of Ultramet, and Sanders D. Rosenberg of GenCorp. For further information, write in 34 on the TSP Request Card. LEW-15519.

Depositing High- T_c Superconductors on Normal-Conductor Wires

Superconductivity is evident at and below a critical temperature (T_c) of 71 K.

Marshall Space Flight Center, Alabama

Experiments have demonstrated the feasibility of depositing thin layers of a high- T_c superconductor on normally electrically conductive wires. The superconductor in question is the 2212 phase of the $\text{Bi}_x\text{Sr}_w\text{Ca}_x\text{Cu}_y\text{O}_z$ material system. The normal conductor is Ag, which was selected because it is chemically compatible with $\text{Bi}_x\text{Sr}_w\text{Ca}_x\text{Cu}_y\text{O}_z$ and has the necessary strength and flexibility.

In the experiments, precursor films of $\text{Bi}_x\text{Sr}_w\text{Ca}_x\text{Cu}_y\text{O}_z$ with thicknesses of a few microns were formed by organometallic vapor deposition (OMCVD) (see Figure 1) onto Ag wires with lengths up to 20 ft (about 6 m) and diameters of 50 and 125 μm . In each case, the wire made two passes through the OMCVD reactor. Typical deposition conditions in the reactor included a temperature of 500 °C (maintained by use of quartz heating lamps) and a winding speed of 6 to 12 ft/h (0.5 to 1 mm/s). The organometallic compounds that contained Bi and Sr were fed into the reactor by Ar (as a carrier gas) flowing through heated bubblers. The organometallic compounds that contained Ca and Sr were dissolved in a solution, which was injected into argon flowing into the reactor. A controlled stream of O_2 also flowed into the reactor.

The precursor film was annealed to remove fluorine (which was part of the organometallic compounds) and to form the superconductive 2212 phase. The

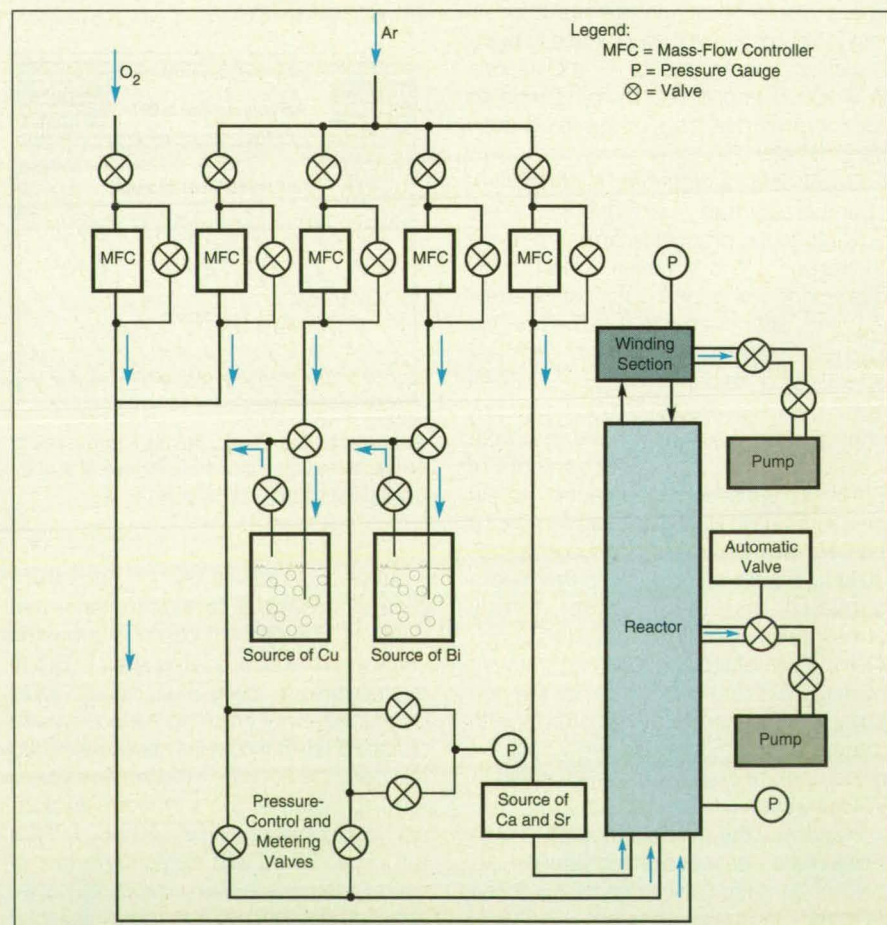

Figure 1. This OMCVD Apparatus coats Ag wire with a layer high- T_c superconductor. The superconductive phase of this material is formed subsequently by annealing under controlled conditions.

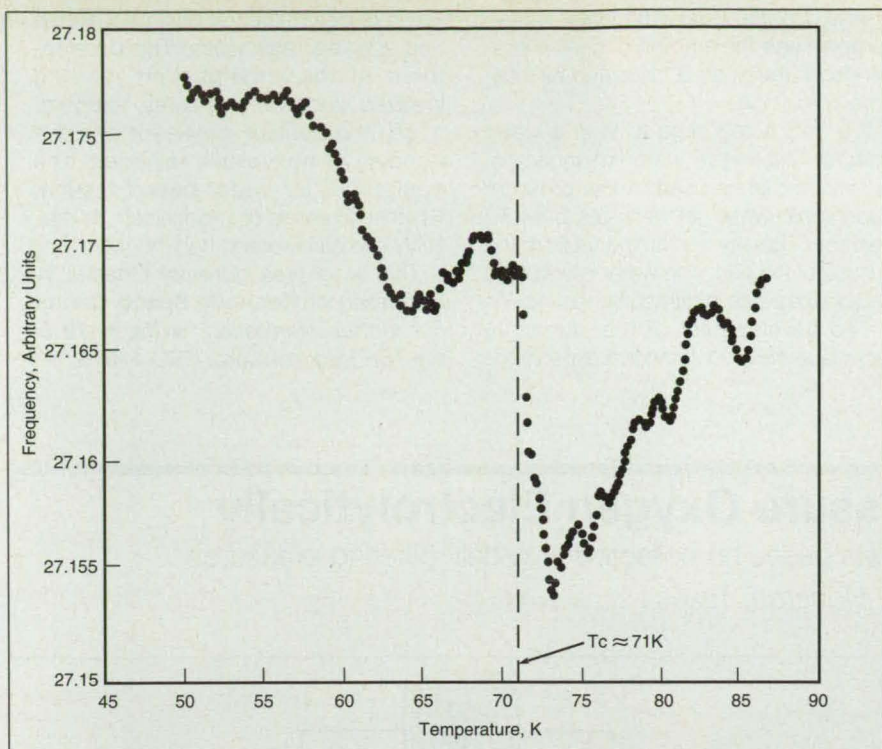

Figure 2. The **Sharp Increase in Frequency** (decrease in inductance) with decreasing temperature in the vicinity of 71 K is evidence of a transition to superconductivity.

fluorine-removal step of the anneal was performed at a temperature of about 750 °C for ½ to 1½ hours in an atmosphere of moist O₂ and Ar (O₂/Ar ratio varying from 1:1 to 3:1). Then the coated wire was heated to a temperature between 830 and 860 °C, held there for 2 to 30 minutes to form the 2212 phase, and finally cooled in the annealing furnace. Best results were obtained with a fluorine-removal time of 1½ hours and a final annealing temperature of 845 °C held for 25 minutes.

One way to determine whether at least part of the surface layer on a wire is superconductive is to wind the wire into a loop that serves as an inductor and to measure the resonant frequency of a circuit that

includes the inductor. If a superconductive surface layer is present, then the resonant frequency can be expected to increase abruptly with the onset of superconductivity as the temperature decreases below T_c . Figure 2 shows an example of such a transition in a specimen that was annealed for 25 minutes.

This work was done by Peter S. Kirlin of Advanced Technology Materials for Marshall Space Flight Center. For further information, write in 2 on the TSP Request Card.

Inquiries concerning rights for the commercial use of this invention should be addressed to the Patent Counsel, Marshall Space Flight Center [see page 20]. Refer to MFS-27297.

Using Water To Analyze Greasy Residues

Water would be substituted for chlorofluorocarbon solvents.

John F. Kennedy Space Center, Florida

Water has been found to be useful as a substitute for chlorofluorocarbon (CFC) solvents in tests to measure the amounts of nonvolatile residues of contaminants (e.g., hydrocarbon greases) on equipment after it has been cleaned. Until recently, CFC's have been the solvents of choice for such tests because they dissolve hydrocarbons readily, are compat-

ible with many materials, are non-flammable and relatively nontoxic, have low boiling temperatures, and can be reclaimed easily. Now, CFC's are known to contribute to depletion of ozone in the stratosphere and are being phased out of use. Water, of course, does not harm the environment and is much cheaper than CFCs.

SYNERGY.

Data Acquisition =
Hardware + Software...



that are made for each other.

Some companies sell data acquisition hardware. Some software. But how many companies sell both hardware and software... that are designed to work TOGETHER?

Since 1979, Strawberry Tree has been designing, selling, and supporting data acquisition solutions for the PC. Hardware solutions like the DATashuttle™ family of parallel port A/D units. Totally compatible software solutions like WorkBench PC™ for Windows™, a powerful, easy-to-use program for data acquisition, control and analysis. Complete solutions, supported by an experienced technical staff.

Whether you're working on a desktop or portable PC, using the DOS, Windows or Mac platforms, we can fulfill your data acquisition needs. Call 1-800-736-8810 now and let us show you how.



Strawberry Tree

Data Acquisition So Smart, It's Simple

160 South Wolfe Road Sunnyvale, California 94086
(408)736-8800 Fax:(408)736-1041 Applelink:DO345

The Strawberry Tree logo is a registered trademark, and WorkBench PC and DATashuttle are trademarks of Strawberry Tree Incorporated. Mac is a trademark of Apple Computer, Inc. Windows is a trademark and Microsoft® is a registered trademark of Microsoft Corporation.

In the older (CFC-based) method, parts to be tested were rinsed with CFC solvents, which were then analyzed for trace amounts of dissolved contaminants. Unacceptably high concentrations of contaminants were taken as indications that the rinsed parts should be recleaned. In the new (water-based) method, a part to be tested is immersed in water and subjected to ultrasonic energy for 10 minutes. Even though water is not a solvent for grease, the ultrasound removes the grease from the part and emulsifies the

grease into the water. The water is then sampled and the amount of grease suspended in the water is measured by total-organic-carbon.

If a part is too large to fit in a water bath, an alternative water-impingement technique can be used: A low-pressure supersonic water jet removes over 80 percent of greasy contaminants from the surface of the part. The water is collected and analyzed as in ultrasonic testing.

The development of the ultrasonic technique involved extensive experimen-

tation to determine the best frequencies and analysis techniques. The development of the impingement method involved studies of pressures, temperatures, and contact angles for effective removal of nonvolatile residues. The equipment for water-based testing, whether ultrasonic or impingement, is relatively inexpensive and dependable.

This work was done by Charles W. Hoppesch of Kennedy Space Center. For further information, write in 79 on the TSP Request Card. KSC-11615.

Generating High-Pressure Oxygen Electrolytically

The cathode is also a barrier that lets gases be collected at widely differing pressures.

Lyndon B. Johnson Space Center, Houston, Texas

An electrolytic cell generates oxygen directly at high pressure at the point of use. The system makes it unnecessary to use a heavy, bulky air compressor or to ship compressed oxygen in heavy tanks. It produces hydrogen as a byproduct, at a pressure that may be different from that of the oxygen, if desired. The cell has been demonstrated in a 4.5-hour endurance test, in which it stably produced oxygen at a pressure 6,000 lb/in.² (40 MPa) higher than that of the hydrogen at a potential of 1.865 V, a temperature of 186°F (359 K), and a current density of 47.8 mA/cm².

The cell dissociates water into its component elements by supplying electrons through a solid palladium cathode and removing electrons through a porous anode (see figure). An aqueous alkaline electrolyte carries current, in the form of hydroxide ions (OH⁻), from cathode to anode. O₂ is generated at the anode, passes through the porous anode material, and is collected. Hydrogen is generated at the cathode, depositing on its surface as ions (H⁺), which combine with palladium atoms to form a palladium hydride (PdH) transition complex. The hydrogen ions diffuse through the solid metal cathode by repeatedly associating with and dissociating from Pd atoms in the crystal lattice. When the hydrogen ions reach the outside edge of the cathode, they combine to form gaseous H₂, which is collected. The cathode transmits hydrogen efficiently. In the endurance test, the amount of H₂ produced was 93.7 percent of the theoretical value based on the amount of electrical charge transferred.

Because there is a solid metal barrier—the palladium cathode—between the O₂ and H₂ collection compartments, the collection compartments can be operated at different pressures. The differential

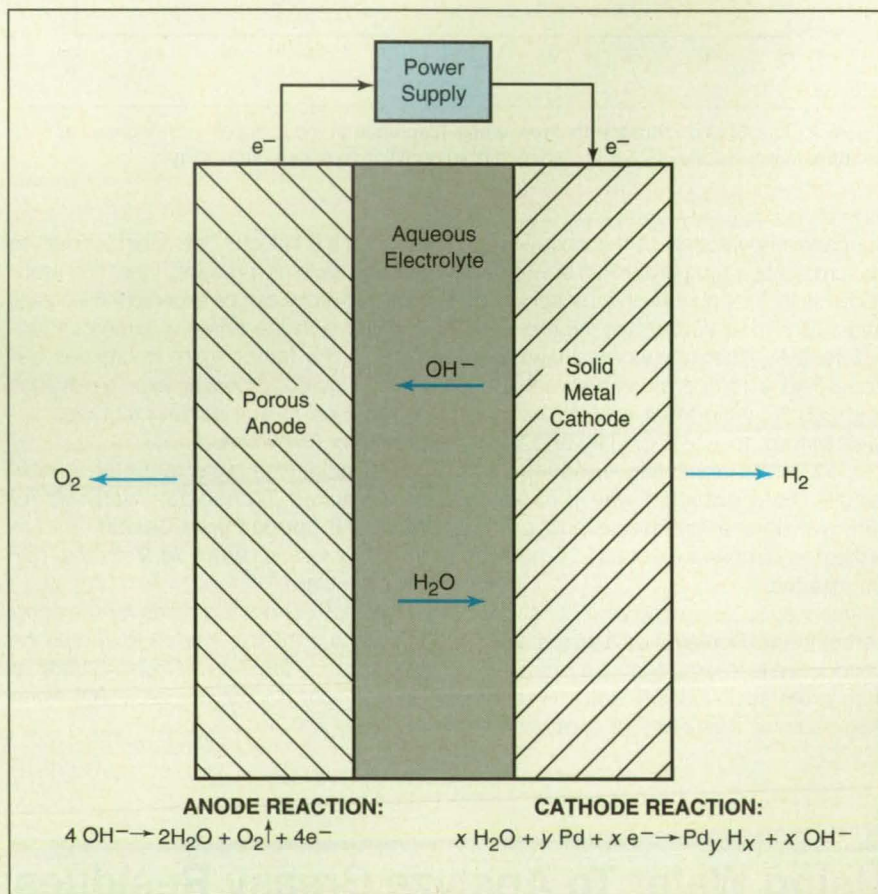

Anode and Cathode Reactions Produce gaseous oxygen and hydrogen, respectively. A power supply removes electrons from the porous anode and supplies them to the solid-metal cathode. The aqueous electrolyte between the electrodes completes the circuit by carrying (OH⁻) to the anode.

pressure is limited only by the mechanical strength of the barrier.

This work was done by F. H. Schubert and D. J. Grigger of Life Systems, Inc., for Johnson Space Center. For further information, write in 13 on the TSP Request Card.

This invention is owned by NASA, and a patent application has been filed. Inquiries concerning nonexclusive or exclusive license for its commercial development should be addressed to the Patent Counsel, Johnson Space Center [see page 20]. Refer to MSC-21577.

Copper Alloy for High-Temperature Uses

Properties include high strength, high thermal conductivity, and compatibility with hydrogen.

Lewis Research Center, Cleveland, Ohio

An alloy of Cu/8Cr/4Nb (numbers indicate parts by atom percent) is improved over older high-temperature copper-based alloys in that it offers enhanced high temperature strength, resistance to creep, and ductility while retaining most of the thermal conductivity of pure copper; in addition, this alloy does not become embrittled upon exposure to hydrogen at temperatures as high as 705°C. The alloy is designed for use in the presence of high heat fluxes and active cooling; for example, in heat exchangers in advanced aircraft and spacecraft engines, and other high-temperature applications in which there is need for a material that has high thermal conductivity, high strength, and resistance to creep. In addition, the high conductivity and hardness of the alloy could be exploited in welding electrodes and in high-voltage and high-current switches and other applications in which wear poses a design problem.

Prepared by rapid solidification of a molten solution of Cr and Nb in Cu, the alloy consists of a finely precipitated strengthening phase of Cr₂Nb in a phase that is mostly Cu. Because both Cr and Nb have very little solubility in solid Cu, the thermal conductivity of the alloy is only slightly less than that of pure Cu. The Cr₂Nb precipitate has a high melting temperature and is highly stable at high temperatures: this leads to long-term stability of the mechanical properties of the alloy during exposure to high temperatures. Thus, the alloy provides the desired combination of high thermal conductivity, high strength, and resistance to creep.

Figure 1 compares the tensile strength and the ductility of this Cu/8Cr/4Nb alloy with those of the commercial alloys NARloy-Z and GLIDCOP AL-15. The ultimate tensile strength of this alloy is significantly greater than that of NARloy-Z between room temperature and 700°C. Softening of the NARloy-Z begins around 500°C, as shown in short-term tensile tests, and can become severe with long-term exposures because of coarsening of the strengthening phases in NARloy-Z. This limits the maximum use temperature of NARloy-Z. In comparison, tests have shown little decrease in the room-temperature strength of Cu/8Cr/4Nb samples aged for up to 100 h at 700°C.

The yield strength of Cu/8Cr/4Nb is comparable to that of GLIDCOP AL-15, but the principal advantage of Cu/8Cr/4Nb over GLIDCOP AL-15 is that Cu/8Cr/4Nb has about twice the ductility at ele-

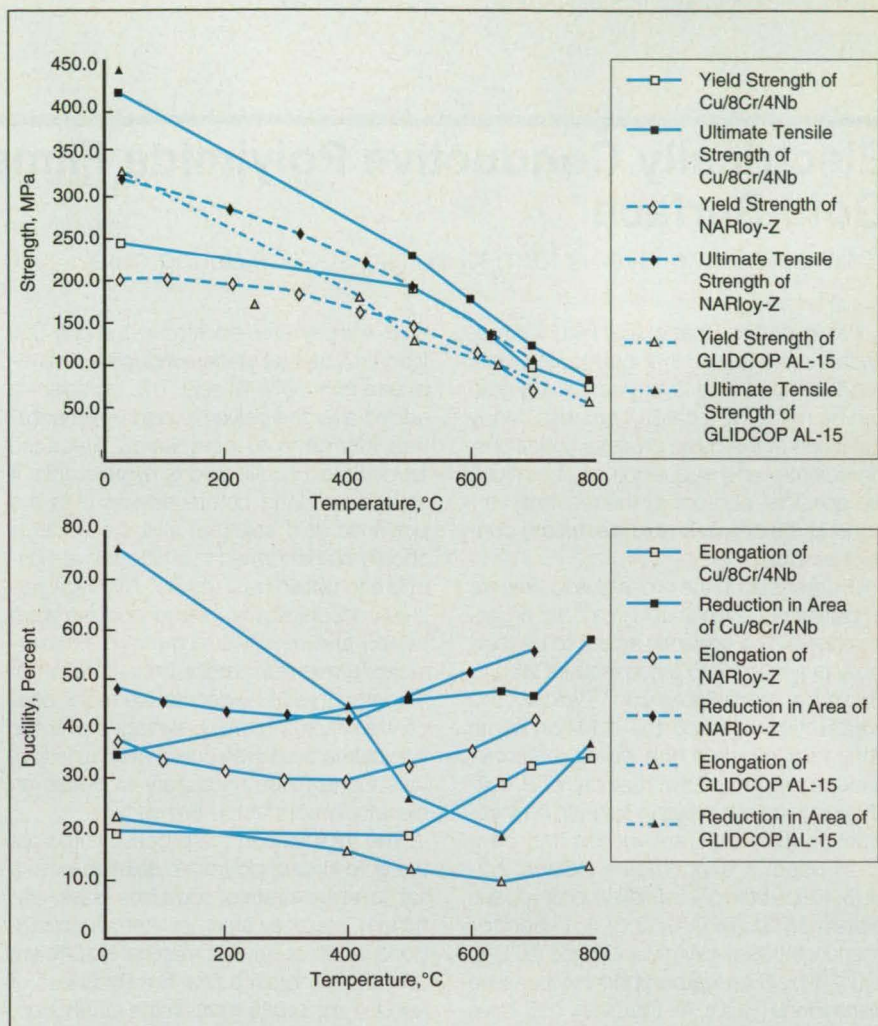

Figure 1. The Tensile Strength and Ductility of Cu/8Cr/4Nb are generally greater than those of NARloy-Z and GLIDCOP AL-15.

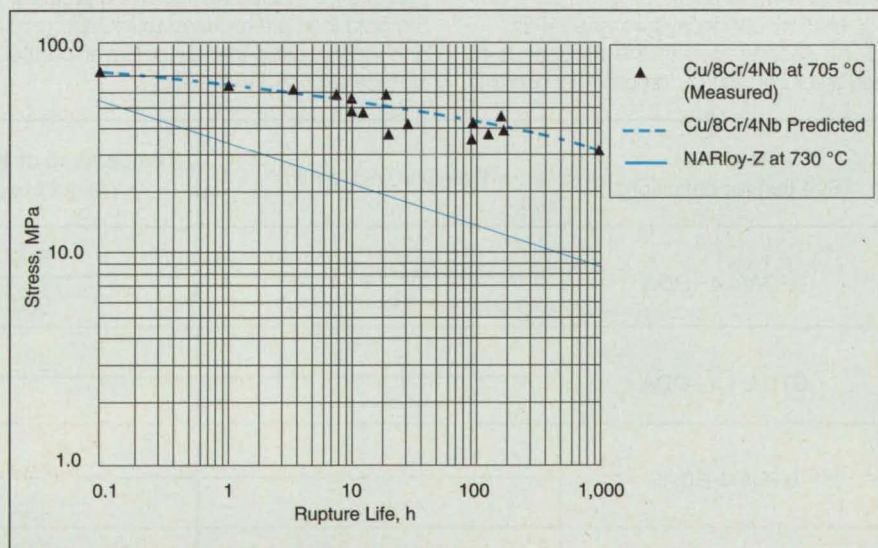

Figure 2. The Stress-Rupture Life of Cu/8Cr/4Nb exceeds that of NARloy-Z.

vated temperatures. Furthermore, unlike Cu/8Cr/4Nb, GLIDCOP AL-15 is vulnerable to a form of embrittlement by hydrogen in which hydrogen reacts with oxygen dissolved in the alloy matrix.

Figure 2 compares the stress-rupture life of Cu/8Cr/4Nb with that of NARloy-Z.

For a given stress, the stress-rupture lives of Cu/8Cr/4Nb samples at 705°C are of the order of 10³ times those of NARloy-Z samples. Alternatively, for a given stress-rupture life, Cu/8Cr/4Nb can support 2.5 to 3 times the stress that NARloy-Z can.

This work was done by Robert L. Dreshfield of Lewis Research Center and David L. Ellis and Gary Michal of Case Western Reserve University.

For further information, write in 38 on the TSP Request Card. LEW-15768.

Electrically Conductive Polyimide Films Containing Gold Surface

Gold-containing layer is formed on film surface during cure.

Polyimide films that exhibit high thermo-oxidative stability and that include electrically conductive surface layers containing gold can be made by a casting process. Many variations of the basic process conditions, ingredients, and sequence of operations are possible, and not all the resulting versions of the process yield electrically conductive films.

The first step in the process is to prepare a solution of polyamic acid in a polar organic solvent. (The polyamic acid is to be thermally polymerized in a subsequent step to obtain the desired polyimide.) Typically, this preparation involves the addition of an equimolar quantity of a suitable dianhydride to an equimolar quantity of a suitable diamine dissolved in N,N-dimethylacetamide (DMAc). Dianhydrides that have been used in experiments include 2,2-bis(3,4-dicarboxyphenyl)hexafluoropropane dianhydride (6FDA), 3,3',4,4'-benzophenonetetracarboxylic dianhydride (BTDA), and 1,4-bis(3,4-dicarboxyphenoxy)benzene dianhydride (HQDEA). Diamines that have been used include 4,4'-oxydianiline (4,4'-ODA), 2,2-bis[4-(4-aminophenoxy)phenyl]hexafluoropropane (4-BDAF), 2,2-bis(3-aminophenyl)hexafluoropropane (6F), and 1,3-bis(aminophenoxy)benzene (APB).

The second step in the process is to add a soluble salt or complex that contains

gold; the preferred additive — the only one tried thus far that yields conductive films — is tetrachloroauric (III) acid. This ingredient is added after the polyamic acid polymerization has gone to completion. Because tetrachloroauric (III) acid is hygroscopic, it should be dried before adding it to the polyamic acid solution, and the addition should be performed in a nitrogen atmosphere to obtain best results. Although various concentrations of gold additive were tested and resulted in metallic film surfaces, a minimum molar concentration of 17 percent (with respect to the molar concentration of polyimide), averaged over the full volume of a given cured polyimide film, was found to be necessary to obtain an electrically conductive film surface.

The third step in the process is to cast the gold-doped polymeric solution onto a flat, level substrate of soda lime glass, aluminum, stainless steel, polytetrafluoroethylene, or other suitable material in sufficient quantity to obtain a final film thickness of about 1 mil (0.025 mm). In the fourth step, the cast film is thermally imidized by forced-air heating at temperatures of 100°C, 200°C, and 300°C, holding at each temperature for 1 h. During this curing process, the gold ions are reduced to metallic gold and incorporated into a gold layer on the surface exposed to the air.

The amount of solvent used in preparing the gold-doped polyamic acid solution need only be sufficient to dissolve all the ingredients and to provide a viscosity suitable for film casting. The success of the process depends partly on the solubility of the gold additive in the polyamic acid solution, though solubility alone does not guarantee the desired results. The best results were obtained with the BTDA/4-BDAF, BTDA/4,4'-ODA, 6FDA/4,4'-ODA, and BTDA/6F resin systems.

These metallic gold-containing polyimides can be used in film and coating applications requiring electrical conductivity, high reflectivity, exceptional thermal stability, and/or mechanical integrity. They should also find commercial potential in areas ranging from thin films for satellite antennas to decorative coatings and packaging.

This work was done by Maggie L. Caplan of Lockheed Engineering & Sciences Co. and Diane M. Stoakley and Anne K. St. Clair of Langley Research Center. For further information, write in 51 on the TSP Request Card.

Inquiries concerning rights for the commercial use of this invention should be addressed to the Patent Counsel, Langley Research Center [see page 20]. Refer to LAR-15068.

Polyimide (See text for definitions.)	Percent Gold in Film	Temperature of 10-Percent Weight Loss, °C
6FDA/4,4'-ODA	0	516
	21	500
BTDA/4,4'-ODA	0	516
	17.3	483
BTDA/4-BDAF	0	503
	17	497
BTDA/6F	0	513
	21	489

Thermo-Oxidative Stabilities of polyimide films both undoped and doped with gold were determined by thermogravimetric analysis. The gold-doped films were somewhat less stable.

Melt-Infiltration Process For SiC Ceramics and Composites

This process yields dense, strong materials at relatively low cost.

Lewis Research Center, Cleveland, Ohio

Reactive melt infiltration produces silicon carbide-based ceramics and composites faster and more economically than do such processes as chemical vapor infiltration (CVI), reaction sintering, pressureless sintering, hot pressing, and hot isostatic pressing. In comparison with CVI, for example, reactive melt infiltration takes minutes instead of days and costs about half as much.

In the reactive-melt-infiltration process, a microporous carbon preform is infiltrated with molten silicon or a molten silicon alloy. The liquid and solid react to form a solid ceramic or composite. The preforms for this process are made by pyrolysis of a polymer resin. If the end product is to be a composite, then preforms containing fibers are used. Products can be formed in complex shapes. They are fully dense, with controlled microstructures and tailored thermomechanical properties. Products have been made in the following compositions:

- Silicon carbide containing silicon (see figure),
- Silicon carbide containing molybdenum disilicide and silicon,
- Silicon carbide containing niobium disilicide and silicon, and
- A composite material consisting of a silicon carbide matrix reinforced by silicon carbide fibers.

Silicon carbide ceramics and composites made by reactive melt infiltration can be used, for example, in combustor liners of jet engines and in nose cones and leading edges of high-speed aircraft and returning spacecraft. In the energy industry, these materials can be used in radiant-heater tubes, heat exchangers, heat recuperators, and turbine parts. These materials are also well suited to the demands of advanced automobile engines.

In the nuclear industry, the nonporous nature of the materials may qualify them for the first-wall and blanket components of reactors. In contrast, SiC/SiC composites made by CVI are about 15 percent porous, and SiC-based materials contain sintering aids (such as boron), which swell when irradiated.

Yet another use is in armor. Although the fracture toughness of monolithic silicon carbide is low, it can be increased by adding various phases, as can readily be done in reactive melt infiltration. Finally, the ability to produce parts in complex shapes and nearly final dimensions makes reactive melt infiltration suitable for the fabrication of silicon carbide cutting tools.

This work was done by Donald R. Behrendt of Lewis Research Center and Mrityunjay Singh of the National Research Council. For further information, write in 67 on the TSP Request Card.

Inquiries concerning rights for the commercial use of this invention should be addressed to the Patent Counsel, Lewis Research Center [see page 20]. Refer to LEW-15767.

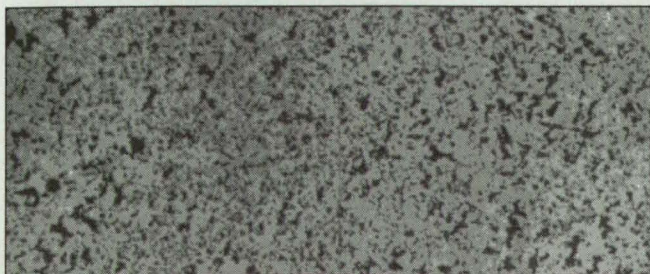

The Microstructure of This Specimen of silicon carbide containing silicon shows no porosity or unreacted carbon.

CM Rapid-Temp Furnaces

Top-notch performance in a bottom-loading furnace.



Quality research starts with bottom-loading furnaces from CM. CM Rapid-Temp furnaces offer faster heating rates and temperature capabilities up to 1800°C. These easy to operate, easy to maintain, furnaces incorporate molybdenum disilicide hairpin heating elements and a precision electrically operated lift. The insulation system's interlocking construction permits easy removal and replacement of components. It's the kind of performance-proven package you expect from the leader in laboratory and research furnaces.

For more information, call (201) 338-6500, FAX (201) 338-1625 or write CM Furnaces at:

CM FURNACES INC.
103 Dewey Street, Bloomfield, NJ 07003

For More Information Write In No. 417

Record Airborne Data & Video

...simultaneously!

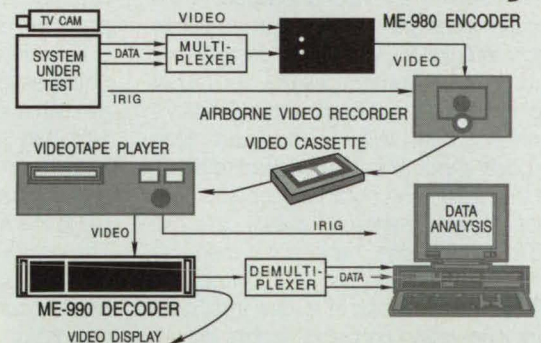

The airborne-qualified ME-980 combines PCM data (2Kb/s to 590Kb/s) with camera video in a single channel for recording on standard 1/4," 1/2," 3/4" and 8mm video recorders.

Base station ME-990 recovers data to original format and timing for analysis. The system is particularly useful with low data rates and where visual images in sync with data are more revealing than data or video alone.

Merlin
ENGINEERING WORKS

1888 Embarcadero Rd, Palo Alto, CA 94303 Phone(415) 856-0900



Computer Programs

COSMIC: Transferring NASA Software

COSMIC, NASA'S Computer Software Management and Information Center, distributes software developed with NASA funding to industry, other government agencies and academia.

COSMIC's inventory is updated regularly; new programs are reported in *Tech Briefs*. For additional information on any of the programs described here, write in the appropriate TSP number.

If you don't find a program in this issue that meets your needs, call COSMIC directly for a free review of programs in your area of interest. You can also purchase the annual *COSMIC Software Catalog*, containing descriptions and ordering information for available software.

COSMIC is part of NASA's Technology Transfer Network.

COSMIC® —

John A. Gibson, Director
Phone (706) 542-3265;
FAX (706) 542-4807
The University of Georgia,
382 East Broad Street,
Athens, Georgia 30602

Computer Programs

These programs may be obtained at a very reasonable cost from COSMIC, a facility sponsored by NASA to make computer programs available to the public. For information on program price, size, and availability, write in the reference number on the TSP and COSMIC Request Card in this issue.



Electronic Components and Circuits

Estimating Delays in ASIC's

This program speeds the design-and-verification cycle by estimating delays before layouts are completed.

Verification is an important aspect of the process of designing an application-specific integrated circuit (ASIC). The design must not only be functionally accurate, but it must also maintain the correct timing. After a circuit has been laid out, one can utilize the back-annotation (BA) method to simulate the design and obtain an accurate estimate of performance. However, this can lead to major design changes. It is therefore preferable to eliminate potential problems early in this process. IFA, the Intelligent Front Annotation program, assists in verifying the timing of the ASIC early in the design process.

Many difficulties can arise during ASIC design processes. In a synchronous design, both long-path and short-path problems can be present. In a modern ASIC, the delays through gates are very dependent on loading. This loading has two main components: the capacitance of the gates being driven and the capacitance of the metal tracks (wires). When using GaAs gate arrays, the capacitance of the metal lines is often the dominating factor. In addition, the

resistance-capacitance delay through a wire of submicron width is significant. Inasmuch as the lengths of wires are unknown before they are placed on and routed across an entire circuit chip, these considerations would seem to force the designer to postpone any realistic verification of timing until near the end of the design process, and obviously such postponement is undesirable.

The IFA program estimates the delays in an ASIC before layout. Currently, the program is designed for Vitesse GaAs gate arrays and Valid computer-aided-engineering workstations, but the algorithm is appropriate for ASIC's and computers of many different types. IFA is especially useful for devices, the delays in which are extremely dependent on the interconnection wiring in them. IFA estimates the lengths of the interconnections from information supplied by the user and information in the netlist. The resulting lengths are also used to constrain a placement-and-routing program, ensuring reasonable results.

IFA takes locality into account to give a better estimate of lengths of wires as well as such known factors as fanout and drive. Although the exact location of a cell is not known, an estimate of the length of wire can be calculated from the location of the net in the ASIC-design-structure hierarchy. The length of each net is estimated by use of the IFA program. This length is then used to run timing analysis or simulation on the design, further using the delay values estimated by IFA. The length of each net is also used to define constraints for the placement-and-routing program, which uses the constraints as limiting values, along with floor-plan information, to assist the placement.

IFA is written in C language for Sun-series computers running SunOS. Sample executable codes for Sun4-series computers are provided with the distribution medium. IFA requires 32M of random-access memory for execution. The standard distribution medium is a 0.25-in. (6.35-mm) stream-

ing-magnetic-tape cartridge in UNIX tar format. Documentation is included in the price of the program. IFA was developed in 1992 and is a copyrighted work with all copyright vested in NASA.

This program was written by Gary Burke, Jeffrey Nesheiwat, and Ling Su of Caltech for NASA's Jet Propulsion Laboratory. For further information, write in 49 on the TSP Request Card. NPO-19025.



Electronic Systems

Event/Time/Availability/Reliability-Analysis Program

This program computes the reliability, maintainability, and availability characteristics of complicated systems.

ETARA is an interactive, menu-driven program that performs simulations for the analysis of reliability, availability, and maintainability. Given a reliability block diagram representation of a system, the program simulates the behavior of a system during a specified interval. Monte Carlo methods are used to generate failure and repair times of components represented by blocks in the diagram as functions of exponential and/or Weibull distributions. The ETARA computer program was written to evaluate the performance of the electrical power system of the Space Station *Freedom*, but the methodology and software can be applied to any system that can be represented by a block diagram.

ETARA can calculate such availability parameters as equivalent availability, state availability (percentage of time at a particular output state capability), continuous duration of a given state, and number of occurrences of a given state. The pro-

gram can simulate the initial allotment of spare parts and the replenishment of spare parts on a resupply cycle. The numbers of failures of blocks are tabulated both individually for each block and by type of block. The total downtime, repair time, and time waiting for spares are also tabulated. The number of technician-hours per year required for maintenance and the reliability of the system, with or without repair, at or above a particular output capability can also be calculated.

ETARA requires the development of a reliability or availability block diagram. The block diagram is a logical representation of the block configuration necessary for the accomplishment of a function. Each block can represent a component, a subsystem, or a system that performs a function that must be represented as either available or unavailable. The blocks do not have to be physically connected equipment in the real system to be connected in the block diagram. The block need only have a role in contributing to the availability of the system. There are no restrictions on the number of total blocks or on the number of blocks in a series, parallel, or *M-of-N* parallel subsystem. In addition, the same block can appear in more than one subsystem if such an arrangement is necessary for an accurate model.

ETARA version 3.3 was developed in 1990. The program is written in IBM APL for an IBM PC-series computer with a math coprocessor.

IBM and IBM PC are registered trademarks of International Business Machines.

This program was written by L. A. Viterna and D. J. Hoffman of Lewis Research Center and Thomas Carr of Northwestern University. For further information, write in 22 on the TSP Request Card. LEW-15083.

Fabrication Technology

Weld-Fill Program

ROCKFILL helps a technician make a weld conform to specifications.

ROCKFILL is a package of software that calculates key robot weld information. Its easy-to-use menu system enables the robot operator to estimate better the number of passes, amount of wire, arc time, and amount of heat that will be put into the particular weld. The software is designed to operate on the work-cell personal computer of the robot and requires no docu-

mentation or training. ROCKFILL is intended for use as a shop aid in the Rocketdyne robotic welding effort, and is not a software tool for design. The program was written under the assumption that the welding process is the gas/tungsten (pulsed/non-pulsed) arc welding (GTAW), commonly referred to as TIG welding.

The significant features of ROCKFILL include the capability to (1) determine whether the robot has enough filler available to make the weld, (2) determine

whether the weld can be completed by the end of the shift, (3) ascertain weld-pass heat inputs, (4) enable the operator to control the number of weld passes needed to fill the weld joint, and (5) enable the operator to make the weld conform better to the weld specifications of the joint. The four main modules of ROCKFILL are the weld-joint menu, the reinforcement amount, the weld-parameter menu, and the program output. Input parameters include the type of material,

Data Acquisition *to GO*

Whether you're acquiring data from a car, lab, or oil well, IOtech's DaqBook™ data acquisition systems for notebook PCs are the most compact solutions available. Battery or AC operable, the 8½" x 11" x 1½" DaqBooks fit neatly beneath your notebook PC. What's more, they offer bidirectional communication at >700 Kbytes/s via your PC's parallel port.

Our DaqBook family includes signal conditioning cards for measuring thermocouples, strain gages, and other transducers.

Software. All DaqBook models include DaqView2™, a Microsoft® Windows™-based data-logging application; Windows DLLs for Visual Basic™ and C; and DOS drivers for Quick Basic™, C, and Pascal. Snap-Master™, Labtech Notebook™, and LabVIEW® support are also available.

Priced from \$695.

Contact us today for your free DaqBook family data sheet and Snap-Master™ for Windows™ demo disk.

(216) 439-4091 • Fax (216) 439-4093

IOtech, Inc.
25971 Cannon Road • Cleveland, Ohio 44146

The following are trademarks of their respective holders: Windows, Visual Basic, Visual C++, Quick BASIC, Microsoft Corporation; Snap-Master, HEM Data Corporation; LABTECH NOTEBOOK, Laboratory Technologies; LabVIEW, National Instruments.

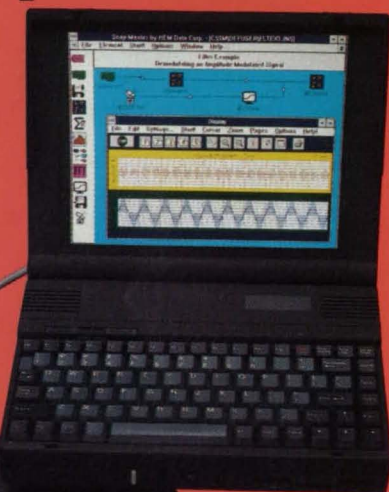

PCMCIA
interface
available
soon

Analog Inputs:

- 12- or 16-bit A/D
- 8 DE or 16 SE channels, expandable up to 256
- 100K sample/s continuous throughput to PC
- 512-location randomly programmable channel/gain sequencing, 10 μs/channel
- Analog & digital triggering
- Many transducer option cards

Analog Outputs:

- Two 12-bit D/A converters

Digital I/O:

- 24 programmable I/O lines, expandable to 192
- Sixteen 100 kHz digital input lines

Frequency/pulse I/O:

- Five 16-bit programmable counter/timers, up to 7 MHz operation



diameter of the wire, and length of the weld. ROCKFILL includes representations of the four basic weld joints that satisfy nearly 99 percent of the basic shop needs — V-groove, J-groove, square (butt) groove, and generic. The use of the generic-joint representation requires no groove-angle input and is the selection of choice for quick calculations. ROCKFILL can be made to reside in memory so that it is automatically loaded when power is first supplied to the computer. Program outputs can be printed easily.

ROCKFILL is written in C Language for IBM PC and compatible computers running MS-DOS. The source code can be compiled properly only with the Aztec C v3.2 compiler; however, an executable code is provided on the distribution disk. The standard distribution medium for this program is one 5.25-in. (13.34-cm) 360K diskette in MS-DOS format. ROCKFILL was developed in 1989. Some documentation is available, showing the basic menu screens, but ROCKFILL is intended as a stand-alone program.

IBM-PC is a registered trademark of International Business Machines Corp. MS-DOS is a registered trademark of Microsoft, Inc.

This program was written by John E. Maslakowski of Rockwell International Corp. for Marshall Space Flight Center. For further information, write in 21 on the TSP Request Card. MFS-29716.

and two directions (bivariate) are considered. These interpolations are associated with linear or cubic Lagrangian/Hermite/Bezier polynomial functions. The algebraic grids can subsequently be smoothed by use of an elliptic-PDE-solving algorithm. For an elliptic grid system, the PDE can be in the form of Laplace (zero forcing function) or Poisson. The forcing functions in the Poisson equation come from the boundary or the entire domain of the initial algebraic grids.

A graphics-interface procedure that uses the Silicon Graphics (GL) Library is included to enable the user to view the variations of a grid at each iteration. This will help the user to modify the grid interactively to match the applications.

TDIGG is written in FORTRAN 77 for Silicon Graphics IRIS-series computers running IRIX. This package requires either MIT's X Window System, Version 11, Revision 4, or SGI (Motif) Window System. A sample executable code is provided on the distribution medium. It requires 148K of random-access memory for execution. The standard distribution medium is a 0.25-in. (6.35-mm) IRIX streaming-magnetic-tape cartridge in UNIX tar format. This program was developed in 1992.

This program was written by Bruce T. Vu of Marshall Space Flight Center. For further information, write in 55 on the TSP Request Card.

Inquiries concerning rights for the commercial use of this invention should be addressed to the Patent Counsel, Marshall Space Flight Center [see page 20]. Refer to MFS-28848.

structure for the design problem. DeMAID displays the modules in the format of an $N \times N$ matrix (called a design structure matrix). As used here, "module" denotes any process that requires input and generates an output. A module could also be a process (e.g., an initialization process) that generates an output but does not require an input. Although DeMAID requires an investment of time to generate and refine the list of modules for input, it could save a considerable amount of money and time in the total design process, particularly in a new design problem in which the order of the modules has not been defined.

The decomposition of a complex design system into subsystems depends on the judgment of the design manager. DeMAID reorders and groups the modules on the basis of the links (interactions) among the modules, helping the design manager make decomposition decisions early in the design cycle. The modules are grouped into circuits (the subsystems) and displayed in an $N \times N$ -matrix format. Feedback links, which indicate an iterative process, are minimized and occur only within a subsystem. Since there are no feedback links among the circuits, the circuits can be displayed in a multilevel format. Thus, a large amount of information is reduced to one or two displays that are stored for later retrieval and modification. The design manager and leaders of the design teams then have a visual display of the design problem and the intricate interactions among the different modules.

The design manager could save a substantial amount of time if circuits on the same level of the multilevel structure are executed in parallel. DeMAID estimates the time saved on the basis of the number of available processors. In addition to decomposing the system into subsystems, DeMAID examines the dependencies of a problem with independent variables and dependent functions. A dependency matrix is created to show the relationship.

DeMAID is based on knowledge-base techniques to provide flexibility and ease in adding new capabilities. Although DeMAID was originally written for design problems, it has proved to be very generally capable in solving any problem that contains modules (processes) that take inputs and generate outputs. For example, one group is applying DeMAID to gain understanding of the flow of data associated with a very large computer program. In this example, the modules are the subroutines of the program.

The design manager begins the design of a system by determining the level of modules that must be ordered. The level is the "granularity" of the problem. For example, the design manager may wish to



Mechanics

Program Generates Two-Dimensional Computational Grids

TDIGG enables the user to view the results of each iteration.

TDIGG is a fast and versatile computer program for generating two-dimensional computational grids for use in programs that solve equations of flow by finite-difference methods. Both algebraic and elliptic grid-generation systems are included. The method for generation of a grid by algebraic transformation is based on an interpolation algorithm, and the elliptic generation of a grid involves, among other things, solving an elliptic partial differential equation (PDE).

Nonuniform grid distributions are carried out by use of a hyperbolic-tangent stretching function. For algebraic grid systems, interpolations in one direction (univariate)

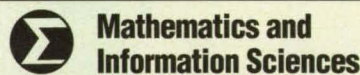

Mathematics and Information Sciences

Program Helps Decompose Complex Design Systems

DeMAID groups modular subsystems on the basis of interactions among them.

Many engineering systems are large and multidisciplinary. Before the design of such new complex systems as large platforms in outer space can begin, the possible interactions among subsystems and their parts must be determined. Once this is done, the proposed system can be decomposed to identify its hierarchical structure.

The DeMAID (A Design Manager's Aid for Intelligent Decomposition) computer program is a knowledge-based software system for ordering the sequence of modules and identifying a possible multilevel

examine disciplines (a coarse model), analysis programs, or the data level (a fine model). Once the system is divided into these modules, the input and output of each model is determined, creating a data file for input to the main program.

DeMAID is executed through a system of menus. The user can choose to plan, schedule, display the $N \times N$ matrix, display the multilevel organization, or examine the dependency matrix. The main program calls a subroutine that reads a rule file and a data file, asserts facts into the knowledge base, and executes the inference engine of the artificial intelligence/expert systems program, CLIPS (C Language Integrated Production System).

To determine the effects of changes in the design process, DeMAID includes a trace-effects feature. Two methods are available to trace the effects of a change in the design process. The first method traces forward through the outputs to determine the effects of an output with respect to a change in a particular input. The second method traces backward to determine what modules must be re-executed if the output of a module must be recomputed.

DeMAID is available in two machine versions: a Macintosh version written in Symantec's Think C 3.01, and a Sun version written in C language. The Macintosh version requires system software 6.0.2 or later and CLIPS 4.3. The source code for the Macintosh version is not compilable under version 4.0 of Think C; however, a sample executable code is provided on the distribution media. QuickDraw is required for plotting. The Sun version requires GKS 4.1 graphics libraries, OpenWindows 3, and CLIPS 4.3. Since neither machine version is compatible with CLIPS 5.0 or later, the source code for CLIPS 4.3 is included on the distribution media; however, the documentation for CLIPS 4.3 is not included in the documentation package for DeMAID. It is available from COSMIC separately as the documentation for MSC-21208. The standard distribution medium for the Macintosh version of DeMAID is a set of four 3.5-in. (8.89-cm), 800K Macintosh-format diskettes. The standard distribution medium for the Sun version of DeMAID is a 0.25-in. (6.35-mm) streaming-magnetic-tape cartridge in UNIX tar format. Both versions include sample input. DeMAID was originally developed for use on VAX VMS computers in 1989. The Macintosh version of DeMAID was released in 1991 and updated in 1992. The Sun version of DeMAID was released in 1992.

This program was written by James L. Rogers, Jr., of Langley Research Center and Laura E. Hall of UNISYS

Corp. For further information, write in 40 on the TSP Request Card. LAR-15018.

HYPERSAMP

This program demonstrates a sampling system based on the hypergeometric distribution.

The Hypergeometric Attribute Sampling System Based on Risk and Fraction Defective (HYPERSAMP) computer program demonstrates an attribute sampling system developed to determine the minimum sample size required for any preselected value for consumer's risk and fraction of nonconforming units. This statistical method can be used in place of MIL-STD-105E sampling plans when a minimum sample size is desirable, such as when tests are destructive or expensive. HYPERSAMP utilizes the hypergeometric distribution and can be used for any fraction nonconforming. The program employs an iterative technique that circumvents the obstacle presented by the factorial of a nonwhole number. HYPERSAMP provides the required hypergeometric sample size for any equivalent real number of nonconformances in the lot or batch under evaluation.

Many currently used sampling systems, such as the MIL-STD-105E, utilize the binomial or the Poisson equations to estimate the hypergeometric distribution when performing inspection by attributes. However, this is primarily because of the difficulty in calculation of the factorials in the hypergeometric distribution. Sampling plans based on the binomial or Poisson equations result in the maximum sample size possible with the hypergeometric distribution.

The difference between the sample sizes in the Poisson or binomial cases on the one hand and the hypergeometric case on the other hand can be significant. In the example of a lot of 400 devices with an error rate of 1.0 percent and a confidence of 99 percent, a sample of 400 (all units) would be needed for the binomial-based sampling plan, and only 273 for a hypergeometric-based sampling plan. The hypergeometric-based sampling plan saves 127 units — a significant reduction in the required sample size.

HYPERSAMP is a demonstration program and is limited to sampling plans with zero defectives in the samples (acceptance number of zero). Since it is a demonstration program, the determination of sample sizes is limited to sample sizes of 1,500 or less.

The Hypergeometric Attribute Sampling System demonstration code is a spreadsheet program written for IBM PC-compatible computers running DOS and Lotus

1-2-3 or Quattro Pro. This program is distributed on a 5.25-in. (13.34-cm), 360K, MS-DOS-format diskette, and the program price includes documentation. This statistical method was developed in 1992.

This program was written by Louis J. DeSalvo of Kennedy Space Center. For further information, write in 66 on the TSP Request Card.

Inquiries concerning rights for the commercial use of this invention should be addressed to the Patent Counsel, Kennedy Space Center [see page 20]. Refer to KSC-11607.



Physical Sciences

Software for Analysis of SAR Data

This program synthesizes images and computes statistical measures of image data.

MacSigma0 is an interactive program for the Macintosh computer that enables the user to display and make computations from data collected by the JPL AIRSAR, ERS-1, JERS-1, and Magellan radar systems. The JPL AIRSAR system is a multipolarimetric airborne synthetic-aperture radar system developed and operated by the Jet Propulsion Laboratory. It includes a single-frequency L-band sensor mounted on the NASA CV990 aircraft and its replacement, the multifrequency P-, L-, and C-band sensors mounted on the NASA DC-8 aircraft. MacSigma0 works with data in the standard JPL AIRSAR output-product format, which is the compressed Stokes-matrix format.

ERS-1 and JERS-1 are single-frequency, single-polarization spaceborne synthetic-aperture radar (SAR) systems launched by the European Space Agency and NASDA, respectively. To be usable by MacSigma0, the data must have been processed at the Alaska SAR Facility and must be in the "low-resolution" format.

Magellan is a spacecraft mission to map the surface of Venus with imaging radar. The project is managed by the Jet Propulsion Laboratory. The spacecraft carries a single-frequency, single-polarization SAR system. MacSigma0 works with framelets of the standard MIDR CD-ROM data products.

MacSigma0 provides four basic functions: synthesis of images (if necessary), statistical analysis of selected areas, analysis of corner reflectors as a calibration measure (if appropriate and possible), and

informative mouse tracking. For instance, the JPL AIRSAR data can be used to synthesize a variety of images such as a total-power image. The total-power image displays the sum of the polarized and unpolarized components of the backscatter for each pixel. Other images that can be synthesized are HH, HV, VV, RL, RR, HHVV*, HHHV*, HVVV*, HHVV* (where H, V, L, and R denote horizontal linear, vertical linear, left circular, and right circular polarization, respectively; one letter in each pair denotes the transmitting polarization, and the other letter in each pair denotes the receiving polarization) phase and correlation-coefficient images. For the complex and phase images, phase is displayed by use of color, and magnitude is displayed by use of intensity.

MacSigma0 can also be used to compute statistics from within a selected area. The statistics computed depend on the type of image. For JPL AIRSAR data, the HH, HV, VV, HHVV* phase, and correlation-coefficient means and standard deviation measures are calculated. The mean, relative standard deviation, minimum, and maximum values are calculated for all other types of data. A histogram of data pertaining to the selected area is also calculated and displayed. The shape of the selected area can be rectangular, linear, or polygonal. The user can select multiple rectangular areas, but not multiple linear or polygonal areas. The statistics and histogram are displayed to the user and can be either printed or saved as a text file.

MacSigma0 can also be used to analyze corner reflectors as a measure of the calibration for data of the types produced by JPL AIRSAR, ERS-1, and JERS-1. It computes a theoretical radar cross section and the actual radar cross section for a selected trihedral corner reflector. The theoretical cross section, the measured cross section, the ratio between them in decibels, and other information are displayed to the user and can be saved into a text file.

For ERS-1, JERS-1, and Magellan data, MacSigma0 simultaneously displays the current location of the cursor in data coordinates and in latitude and longitude coordinates. It also displays the radar cross section, the angle of incidence (for Magellan data), the original pixel value (for Magellan data), and the noise-power value (for ERS-1 and JERS-1 data).

Gray-scale computed images can be saved in a byte format (a headerless format that saves the image as a string of byte values) or a PICT format (a standard format readable by other image-processing programs for the Macintosh). Images can also be printed.

MacSigma0 is written in C for use on the Macintosh series of computers. The minimum configuration requirements for

MacSigma0 are System 6.0, Finder 6.1, 1 Mb of random-access memory, and at least a 4-bit color or gray-scale-graphics display unit. MacSigma0 is also compatible with System 7. Apple's Macintosh Programmers Workshop (MPW) 3.2 and version 3.2 of the MPW C-language compiler are needed to compile the source code. The source code will not be compileable with a later version of the compiler; however, the compiled application program that will run under the minimum hardware configuration is provided on the distribution medium. In addition, the distribution medium includes an executable code that runs significantly faster but requires a 68881-compatible math coprocessor and a 68020-compatible central processing unit. Since JPL AIRSAR data files can be very large, it is often desirable to reduce the size of a data file before transferring it to the Macintosh computer for use in MacSigma0. A small FORTRAN program that can be used for this purpose is included on the distribution medium.

MacSigma0 can print statistics on any output device that supports QuickDraw, and it can print images on any output device that supports QuickDraw or PostScript. The standard distribution medium for MacSigma0 is a set of five 1.4-Mb Macintosh-format diskettes. This program was developed in 1992 and is a copyrighted work with all copyright vested in NASA. Version 4.2 of MacSigma0 was released in 1993.

This program was written by Lynne Norikane, Anthony Freeman, and Howard A. Zebker of Caltech for NASA's Jet Propulsion Laboratory. For further information, write in 35 on the TSP Request Card. NPO-19060.



Materials

Predicting Properties of Composite Materials

MICSTRAN computes overall thermoelastic parameters and stresses by micromechanical analysis.

Composite materials are being utilized in aerospace and many other high-technology applications. The ability to tailor the properties of a composite by the appropriate selection of its fiber and matrix constituents is a major advantage. The Micromechanical Combined Stress Analysis (MICSTRAN) computer code provides the

materials engineer with an easy-to-use personal-computer-based software tool to calculate overall properties of a composite, given the properties of the fibers and matrix.

To assess the ability of the composite to carry structural loads, the design engineer needs to calculate the internal stresses in the composite. MICSTRAN can calculate such internal stresses within a composite ply under combined thermal and mechanical loading. It is based partly on the assumption that the fibers have a circular cross section and are arranged either in a repeating square or diamond pattern within a ply. It uses a classical elasticity solution technique and has been demonstrated to calculate stresses accurately.

Input to MICSTRAN consists of such transversely isotropic fiber properties and isotropic matrix properties as moduli of elasticity and rigidity, Poisson's ratios, and coefficients of thermal expansion, plus volume fractions of fibers and matrix. Loading input consists of a temperature change and ply stresses. All six stress components can be specified as input to analyze a complete three-dimensional stress state in a ply.

Output consists of overall thermoelastic constants and stresses. Computed stresses that can be requested as outputs include those along the fiber/matrix interface, along the model boundaries, along circular arcs, or at points specified by the user and located anywhere in the model. The MICSTRAN program takes advantage of the MicroSoft WINDOWS graphical user interface program.

MICSTRAN is written in FORTRAN 77 for IBM PC-series and compatible computers running MS-DOS. This program is designed to run on MicroSoft WINDOWS 3.0 or later and contains calls to the MicroSoft QuickWin libraries that are available with MicroSoft FORTRAN v5.1. A sample executable code is included on the distribution media. It requires 2.5 Mb of random-access memory for execution. The standard distribution medium for this program is one 5.25-in. (13.34-cm), 360K, MS-DOS-format diskette. It is also available on a 3.5-in. (8.89-cm), 720K MS-DOS-format diskette. The contents of the diskettes are compressed by use of the PKWARE archiving software tools. The utility to unarchive the files, PKUNZIP.EXE, is included. An electronic copy of the user's manual is included on the distribution media in MicroSoft WORD for WINDOWS format. Paper documentation consists of the user's manual plus a 33-page theory manual, NASA Technical Memorandum 107575. MICSTRAN was developed in 1992.

This program was written by Rajiv A. Naik of Analytical Services and Materials, Inc., for Langley Research Center. For further information, write in 41 on the TSP Request Card. LAR-15005.



Adjustable Deflector for Ultrasonic C-Scan

Modification of a two-axis scanner is an economical alternative to a more-complicated scanner.

Goddard Space Flight Center, Greenbelt, Maryland

An adjustable deflector increases the versatility of an ultrasonic C-scan system equipped with a two-axis (x - y) translation stage. The adjustable deflector enables the system to scan along an additional axis that can be perpendicular (z axis) or tilted (z' axis) with respect to the y axis. For example, with the help of the adjustable deflector, the system can execute a rectilinear raster scan of an inclined surface like that of an I beam that is tilted with respect to the y axis of the x - y translation stage. Thus, modifying a two-dimensional scanner by equipping it with the adjustable deflector is an economical alternative to installation of a more-complicated scanning mechanism that may have three translational and two rotational degrees of freedom.

Figure 1 illustrates the use of the adjustable deflector in scanning an angled plate or beam specimen that is oriented with one of its axes along the x axis of the translation stage and is tilted to angle α with respect to the y axis. The deflector is immersed, along with the specimen, in a tank of water or other ultrasound-coupling medium. The incident and return ultrasonic beams are vertical (they propagate along the z axis) at the ultrasonic probe, which is mounted on the x - y translation stage. (Alternatively, the tank can be mounted on the translation stage.) A typical motor-driven x - y translation stage for an ultrasonic system also includes a manual z -axis adjustment.

To obtain a valid C-scan image, it is necessary to make the incident and return ultrasonic beams perpendicular to the surface of the specimen at the spot being scanned. In this case, the angles of incidence and reflection needed to satisfy this condition are obtained by orienting the deflector with one of its axes oriented along the x axis and tilting its other axis to an angle $\beta = \frac{1}{2}(\alpha + \pi)$ with respect to the y axis. With the adjustable deflector thus oriented, motion of the ultrasonic probe (or of the tank) along the x axis produces an ultrasonic C-scan axis line image of the specimen, while an increment of motion along the y axis (as in moving to the next

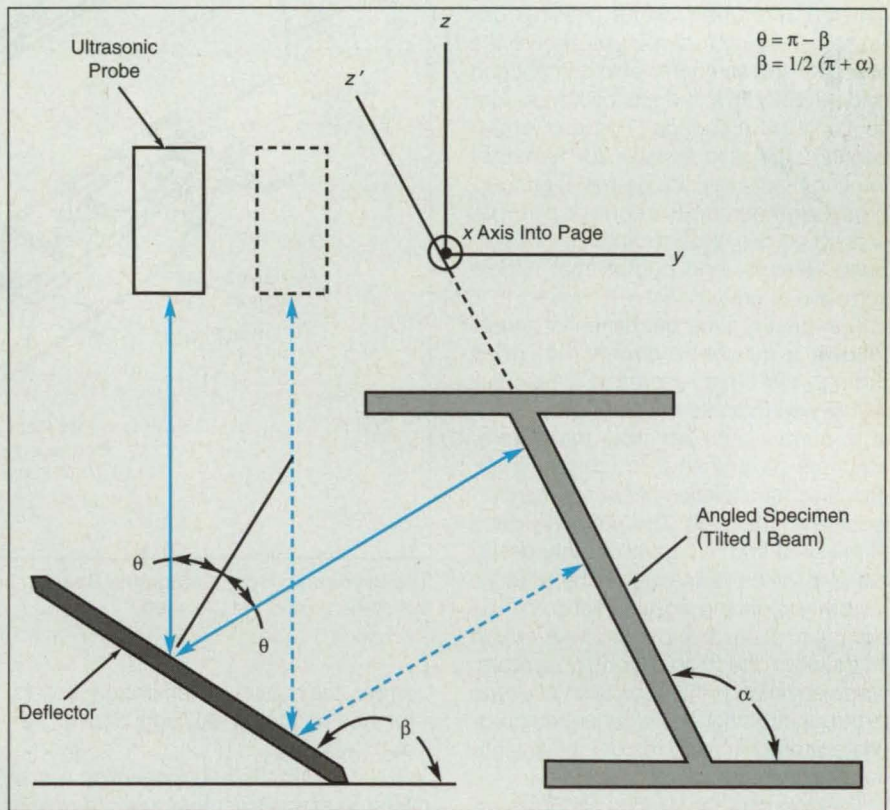

Figure 1. The **Adjustable Deflector Is Tilted** to angle β to turn the ultrasonic beam to normal incidence upon the specimen. A typical specimen could be, for example, a tilted I beam, a composite-material stiffener, or a composite-material tube of parallelogram cross section.

line in the raster) results in an increment of position along the z' axis. Thus, the standard x - y scan has been converted to an x - z' scan.

Figure 2 illustrates a sun-and-planetary-gear mechanism that can be used to adjust the deflector. The deflector should have a fine surface finish and should be made of a material (e.g., glass) that has a high acoustic impedance in comparison with water. The length of the deflector along the x axis should be at least the length of the scan, and the height of the deflector should be at least equal to that of the specimen.

This work was done by E. James Chern of Goddard Space Flight Center. No further documentation is available. GSC-13591.

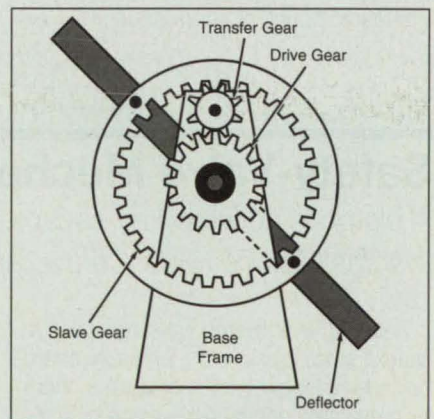

Figure 2. The **Deflector Mechanism** is an accessory to the x - y C-scan assembly. It is placed in the specimen-immersion tank with its axis of rotation parallel to the x scan axis.

Cryogenic Hybrid Magnetic Bearing

Permanent magnets provide suspension, while electromagnets provide control.

Lewis Research Center, Cleveland, Ohio

The cryogenic hybrid magnetic bearing (see figure) is an example of a class of magnetic bearings in which permanent magnets and electromagnets are used to suspend shafts. The electromagnets provide active control of the position of the shaft. This bearing can operate at temperatures from -320°F (-196°C) to 650°F (343°C); it is designed for possible use in rocket-engine turbopumps, where the effects of the cryogenic environment and fluid severely limit the lubrication of conventional ball bearings. This and similar bearings are also suitable for terrestrial rotating machinery; for example, gas-turbine engines, high-vacuum pumps, canned pumps, precise gimbals that suspend sensors, and pumps that handle corrosive or gritty fluids.

The flux from the permanent magnets follows a magnetic circuit that goes through the shaft, providing a bias flux that serves to make the force proportional to current. The flux from the electromagnets also goes through the shaft, providing for alteration of the net magnetic force on the shaft. The lateral deviation of the shaft from a central or other designated position is measured by precise, rapidly responding position sensors. The position data are processed by an associated electronic control system, which commands the application of power to the electromagnets to generate appropriate lateral forces to restore the shaft to the designated position.

The design of the bearing also includes the following notable features:

- The magnetic field and circuit have a homopolar configuration, which suppresses eddy-current losses.
- The overall electromechanical design takes account of resonances; for ex-

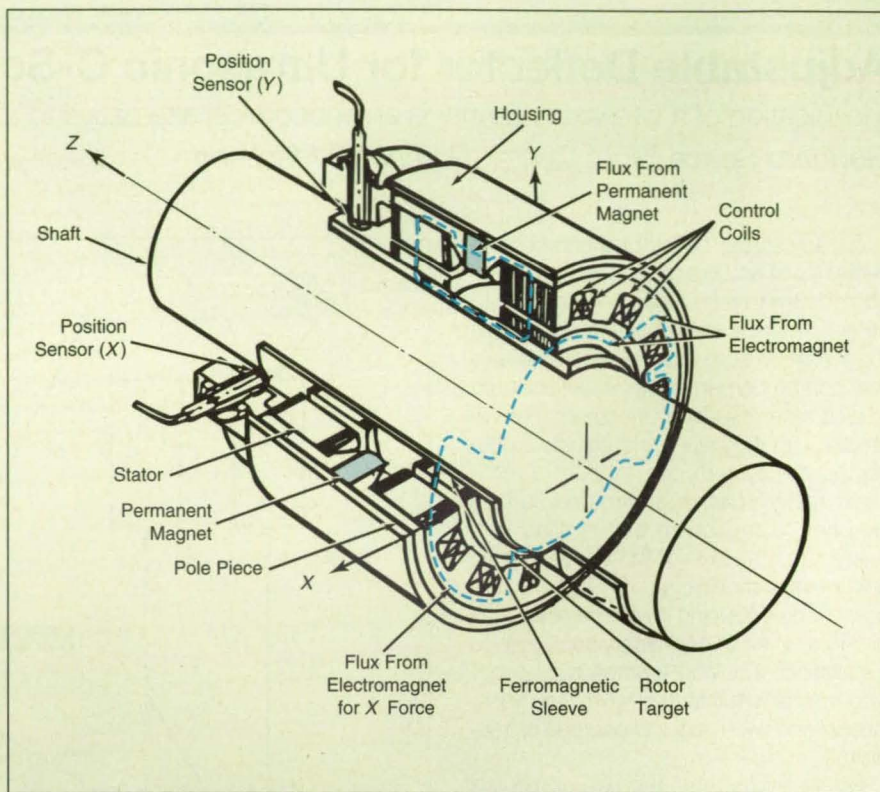

The Cryogenic Hybrid Magnetic Bearing provides noncontact suspension and active control of the position of the shaft.

ample, the control system includes filters for use in tuning through critical frequencies.

The cryogenic hybrid magnetic bearing offers several advantages over the most nearly equivalent commercial magnetic bearing: Its optimized magnetic circuit reduces eddy-current heating and losses by a factor of more than 10, enabling operation at greater speeds without compromising the structural integrity of the shaft.

Its control circuitry is much smaller and consumes much less power than does the control circuitry of the commercial unit. Its weight is less than that of the commercial unit.

This work was done by Crawford R. Meeks of AVCON and Eliseo DiRusso and Gerald V. Brown of Lewis Research Center. For further information, write in 24 on the TSP Request Card. LEW-15517.

Safety-Valve Mechanism for Pressure-Vessel Window

A piston is activated by escaping gas.

Marshall Space Flight Center, Alabama

A pressure-activated valve mechanism seals a small window in a pressure chamber if the window cracks or breaks, thereby preventing continued leakage or sudden decompression. The window is used in experiments that involve the optical observation (e.g., Raman scattering of a laser beam) of processes in the chamber.

The valve mechanism is activated by pressure from gas leaking through the window. The mechanism includes a piston connected through a crank linkage to a 90° plug valve. The piston rides in a cylinder, the axis of which is concentric with the window (see figure). The housing that contains the mechanism also contains the

source of light and other optical and electronic components used to observe through the window. The electrical connections for these components pass through sealed fittings in the wall of the housing to the outside.

If gas leaks from a crack in the window, pressure builds up inside the hous-

ing. When the pressure is high enough to overcome the friction on the piston, the piston moves away from the window, turning the crank and thereby closing the plug valve, which seals the window and the pressure vessel against further leakage.

The housing does not have to withstand the full pressure in the vessel — only the relatively low pressure needed to start the piston moving. It therefore can be relatively small, lightweight, and thin-walled.

This work was done by E. J. McCoomb of United Technologies Corp. for Marshall Space Flight Center. No further documentation is available.

Inquiries concerning rights for the commercial use of this invention should be addressed to the Patent Counsel, Marshall Space Flight Center [see page 20]. Refer to MFS-28760.

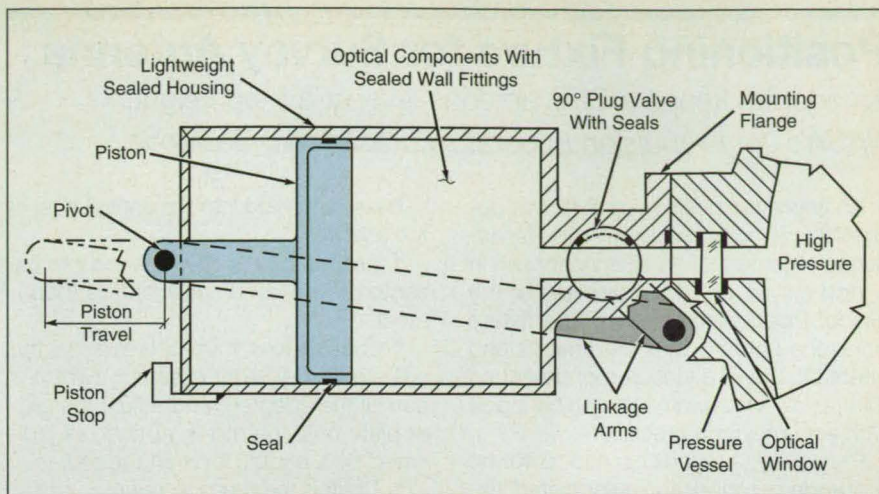

The **Piston Slides to the Left** as pressure builds in the housing. By the time the piston reaches the piston stop, it has turned the crank linkage and closed the plug valve. Parts of the pressure vessel and mounting flange are shown cut away to give a clearer view of the linkage arms.

Torsion and Bending Alleviator

This device couples two shafts while relieving excessive loads between them.

Lyndon B. Johnson Space Center, Houston, Texas

The mechanical device shown in the figure couples two shafts called the "upper shaft" and the "mounting shaft," while limiting the torsional and bending loads that can be transmitted between them. A bending moment in the upper shaft is transmitted to the wobble plate, which, in response, pivots at a point of contact between its rounded edge and the inside of the lip at the upper end of the outer housing. This pivoting action forces the thrust pin downward against the spring plate, thereby compressing the Belleville springs.

The springs absorb the bending moment and tend to restore the wobble plate to its original position. The Belleville springs can be preloaded — that is, they can be compressed by a preset amount when the coupling is assembled — so that the device transmits a bending moment until it exceeds a preset limit.

Torsional moment in the upper shaft is transmitted to the outer housing through serrations (not shown in the figure) in the edge of the wobble plate that mate with serrations in the lip of the outer housing. The outer housing is directly attached to the ball housing, which contains spring-loaded balls that ride on a cammed outer surface of the mounting shaft. The force of the springs on the balls tends to drive them down the ramps of the cammed surface so that they resist the circumferential displacement caused by the torsional moment. The ball springs can also be preloaded, allowing transmission of a preset torsional moment before they slip

past the tops of the cammed surfaces and thereby relieve the torsional moment.

This work was done by Thomas R. Doebbler and Preston E. Kent of Lock-

heed Engineering & Sciences Co. for Johnson Space Center. For further information, write in 32 on the TSP Request Card. MSC-22275.

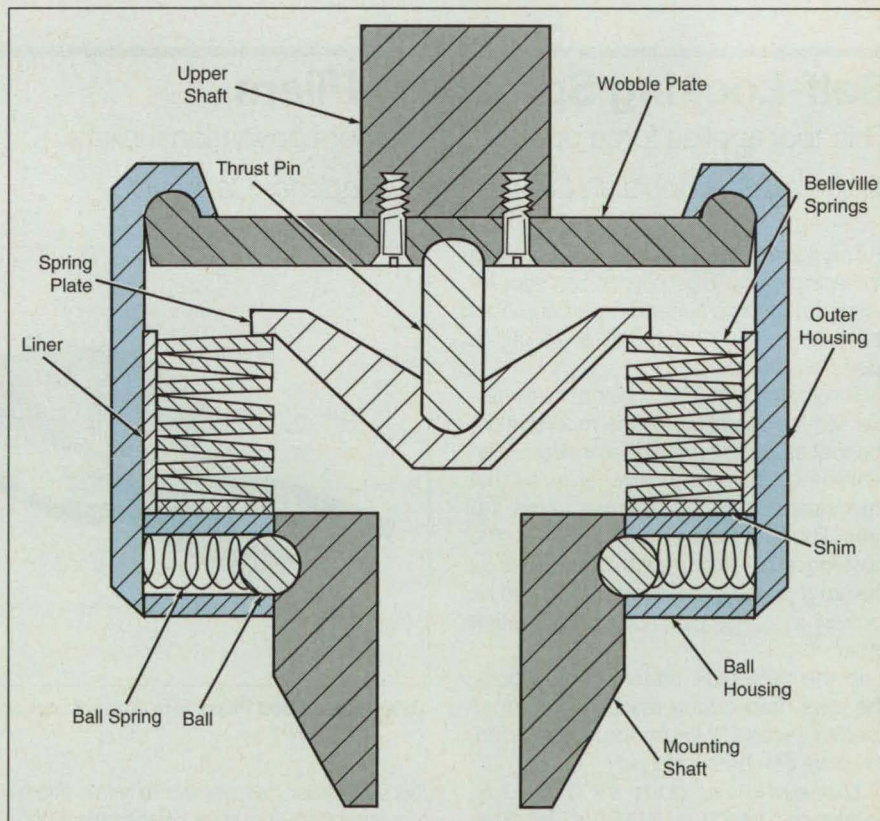

Torsion and Bending Loads between the upper and mounting shafts are relieved in the coupling by the ball springs and Belleville springs, respectively. Both sets of springs can be adjusted so as not to relieve loads below preset limits.

Positioning Fixture for Survey Antenna

An adapter keeps a GPS antenna level at a fixed height.

NASA's Jet Propulsion Laboratory, Pasadena, California

An improved positioning fixture is designed to simplify and accelerate the accurate alignment of an antenna for use in a land survey aided by satellites of the Global Positioning System. The fixture holds the antenna at a fixed height and orientation over a station monument so that survey measurements can be made with accuracy and precision.

Previously, a technician had to set up a standard tripod and associated fixtures — a painstaking and time-consuming chore for an inexperienced technician. Moreover, the setup alignment could easily be lost without the technician's knowledge.

The improved positioning fixture includes an adapter that fits on a standard survey tripod, plus a fixed-height rod. These components are used to center and level the antenna (see figure). To use the fixture, the technician follows these steps:

- Set up the tripod so that it is approximately centered over the monument; neither the adapter nor the tripod head has to be level at this point.

- Insert the rod into the central hole of the adapter.

- Insert the lower tip of the rod into the center of the benchmark on the monument.

- Loosen four thumbscrews on the adjustable x-y slider assembly (which is part of the adapter), and adjust the slider plate until the rod is vertical, as indicated by a bubble level on the rod.

- Tighten the thumbscrews.

- Slowly rotate the rod through a full circle. The bubble should stay centered.

- If the bubble drifts from center during rotation, adjust two of the three screws on the bottom of the bubble level, and rotate the rod again. Repeat this until the bubble stays centered. When it does, the antenna is positioned and oriented properly.

This work was done by Steven J. DiNardo and Mark A. Smith of Caltech for NASA's Jet Propulsion Laboratory.

For further information, write in 72 on the TSP Request Card. NPO-18919.

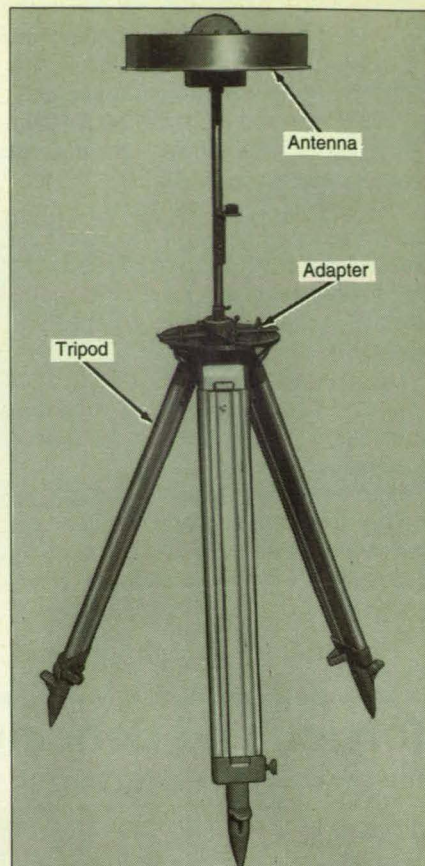

The **Adapter and Tripod** hold a rod that, in turn, holds an antenna. The rod is inserted in the survey station monument under the tripod.

Self-Locking Spreading Pliers

This tool applies force opposite to that of conventional pliers.

NASA's Jet Propulsion Laboratory, Pasadena, California

The figure shows a pair of self-locking spreading pliers. This tool can be used, for example, to force surfaces apart and hold them at a fixed separation or to grip a tube from the inside.

The tool is a modified pair of commercial self-locking pliers. In the modification, the tool as supplied is disassembled, then reassembled with crossover arms so that the gripper jaws face outward (see figure). The arms can be locked in place pushing away from each other, just as the arms on the unmodified version can be locked in place pushing toward each other.

In the prototype shown in the figure, the jaws have a long reach but produce useful leverage. If larger force is needed, the jaws can be shortened.

This work was done by Donald B. Bickler of Caltech for NASA's Jet Propulsion Laboratory. No further documentation is available.

In accordance with Public Law 96-517,

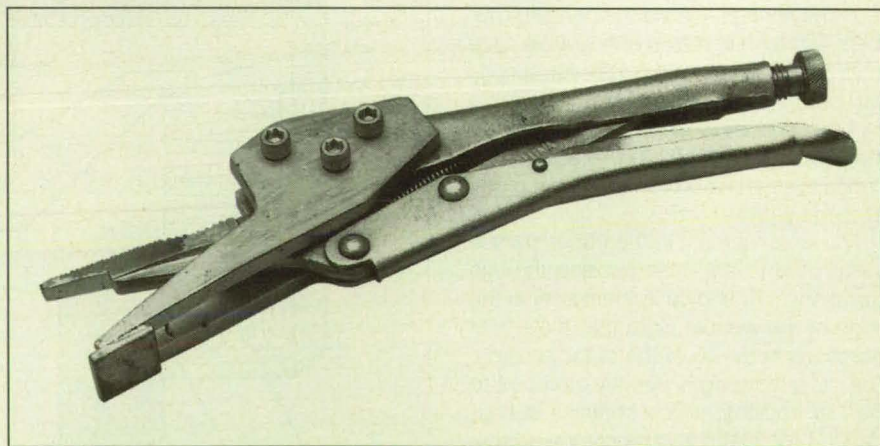

Jaws of Modified Pliers face outward instead of inward.

the contractor has elected to retain title to this invention. Inquiries concerning rights for its commercial use should be addressed to: William T. Callaghan; Manager; Technology Commercialization; JPL-301-

350; 4800 Oak Grove Drive; Pasadena, CA 91109.

Refer to NPO-18953, volume and number of this NASA Tech Briefs issue, and the page number.

Spring- and Air-Suspension Mechanism for Testing Structures

Motion of the test article is relatively unconstrained in all six degrees of freedom.

Langley Research Center, Hampton, Virginia

The figure illustrates a test structure connected at one end to a mechanism that supports the weight of that end but otherwise allows it to move relatively freely in translation along, and rotation about, all three principal coordinate axes. Mechanisms of this type are called "zero-spring-rate mechanisms" (ZSRM's) because they are designed to support the structure in the manner of a spring suspension that exhibits approximately zero stiffness (zero spring rate) within some range of motion about a nominal equilibrium or central support position. ZSRM's are used to minimize mechanical interactions between supports and structures under test, so that the vibrational, rotational, and translational characteristics of the structures can be measured accurately, with minimal spurious dynamics introduced via the supports.

Unlike some older ZSRM's, this suspension mechanism does not include overhead cables, which necessitate large amounts of overhead clearance and overhead support structures: this suspension mechanism is more compact (it can be much smaller than the structure) and supports the structure from below. In comparison with most older ZSRM's, this one provides a wider range of relatively unconstrained motion in some degrees of freedom. The major structural members of this mechanism can be made of lightweight composite (e.g., graphite-fiber/epoxy) materials to reduce further its effects on the overall dynamics. In addition, this mechanism is simple and can be constructed easily.

As shown at the bottom of the figure, pressurized air is supplied via a flexible hose to the base of the suspension mechanism. The air bleeds out through holes on the bottom surface of the base, forming an air cushion that minimizes the frictional resistance to horizontal motion. Thus, the suspension mechanism allows essentially unconstrained translation along the x and y axes and rotation about the z axis.

The mechanism includes a coupling rod attached to the test structure via a threaded rod. A support plate at the top of the mechanism includes a large hole (hidden in the figure) that allows a fairly wide range of horizontal motion of the upper end of the coupling rod. Two predominantly vertical tension springs attached to the support plate and the cou-

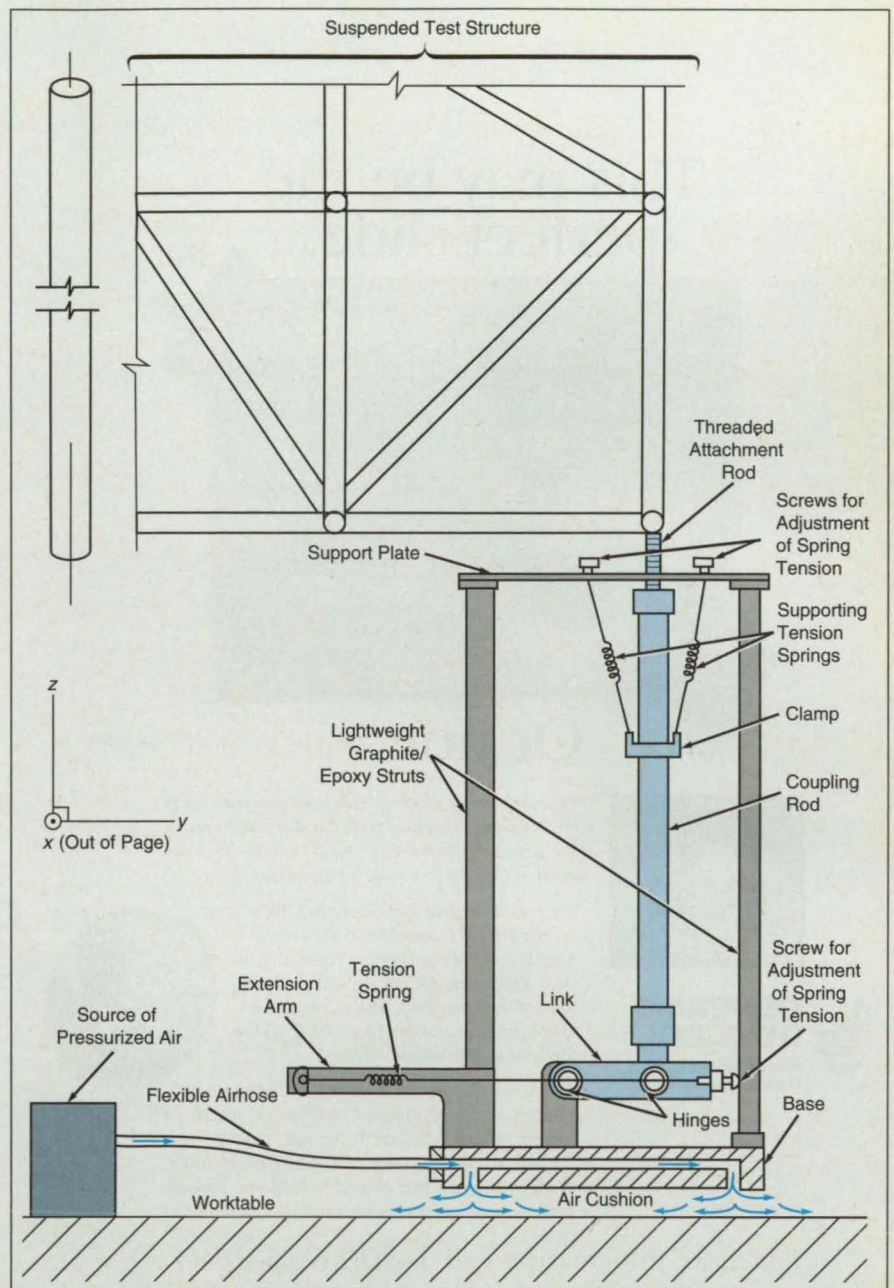

This **Spring- and Air-Suspension Mechanism** supports the weight of one end of the test structure, yet allows that end to move almost completely unhindered as though it were weightless and not attached to a suspension.

pling rod support the weight of the structure, the rods, and hinges and a link at the bottom of the coupling rod. The hinges and link allow essentially free vertical motion of the rods. Two predominantly horizontal tension springs (only one can be seen in the figure) connected between a horizontal extension arm and

one end of the link counteract the stiffness of the supporting tension springs when the structure and coupling rod are displaced vertically from the nominal equilibrium or central support position. Thus, there is very little spring stiffness against free vertical (z-axis) translation of the structure.

This may be the perfect slide.



Or not.

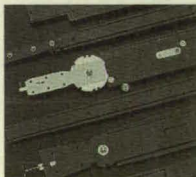

1410 S. Post Road
P.O. Box 39100
Indianapolis, Indiana
46239-0100

FAX 317.898.2917

Because, when it comes to slides, one size does not fit all. But General Devices probably does have exactly the low-cost Chassis Trak® solid bearing slides you need — in stock and ready for immediate shipment.

Slides with detents and pivots that allow your equipment to be opened and tilted down for easy inspection or service. Slides that fit your application exactly, to make specifying and ordering easy. Slides designed for quick, easy installation. Slides made to last for years of dependable service.

And if by chance we don't have the standard product you need, General Devices will modify or custom manufacture exactly the right slides for you. To find out more, contact General Devices today. We'll send you a free catalog to help you find the perfect electronic packaging solutions.

For more information call 1-800-626-9484

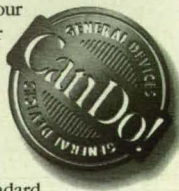

Ultrasonic Measurement of Elastic Constants of Composites

Principal measured quantities are times of flight and critical angles.

NASA's Jet Propulsion Laboratory, Pasadena, California

An ultrasonic testing system yields data on the elastic constants of a matrix/fiber laminated composite material. This system is related to the one described in "Ultrasonic System Measures Elastic Properties of Composites" (NPO-18729), *NASA Tech Briefs*, Vol. 17, No. 11 (November 1993), pages 76-77. The tests performed with this system are nondestructive, and they involve access by ultrasonic probes to only one side of a material specimen. In comparison with some other available ultrasonic testing systems, this system is relatively inexpensive, and it is based on a testing technique that is simpler and rapidly yields more-accurate results.

This system (see figure) is controlled by a personal computer, which also processes the measurement data. The specimen is immersed in a tank of water along with a transmitting and a receiving ultrasonic transducer. The positions and orientations of the transducers relative to the specimen are controlled to obtain the desired polar angle of the incident ultrasonic beam relative to the orientation of the fibers and to maintain the angle of measured reflection equal to the angle of incidence.

The remaining two degrees of freedom are rotations about the x and y axes. At the coupling rod, these rotations are resolved into combinations of horizontal and vertical translations, which are essentially unrestrained as explained above. Thus, the suspension mechanism allows essentially unrestrained motion in all six degrees of freedom.

This work was done by Stanley E. Woodard of Langley Research Center. For further information, write in 17 on the TSP Request Card.

Inquiries concerning rights for the commercial use of this invention should be addressed to the Patent Counsel, Langley Research Center [see page 20]. Refer to LAR-14684.

Two sequences of measurements are taken on a given specimen. First, one of the transducers is set to function as both a transmitter and receiver at normal incidence, and pulse/echo time-of-flight measurements are taken to determine the speed of bulk waves propagating through the laminate. Next, the two transducers are set to operate in pitch/catch mode at various angles of incidence and reflection and various polar angles with respect to the fibers: the resulting measurement data include times of flight (equivalently, speeds of propagation) and critical angles for total reflection.

For the purpose of analysis, the composite specimen is assumed to be an ideal transversely isotropic material, which can be characterized by five independent constants that represent aspects of its elasticity at various orientations. Equations that express the relationships among the five constants, the mass density of the material, the critical angles, and the speeds of propagation at various angles, are incorporated into a program that is executed on the computer. The program combines the data from the two sequences of measurements and processes them into values of the elastic constants. The combination of computer analysis and control

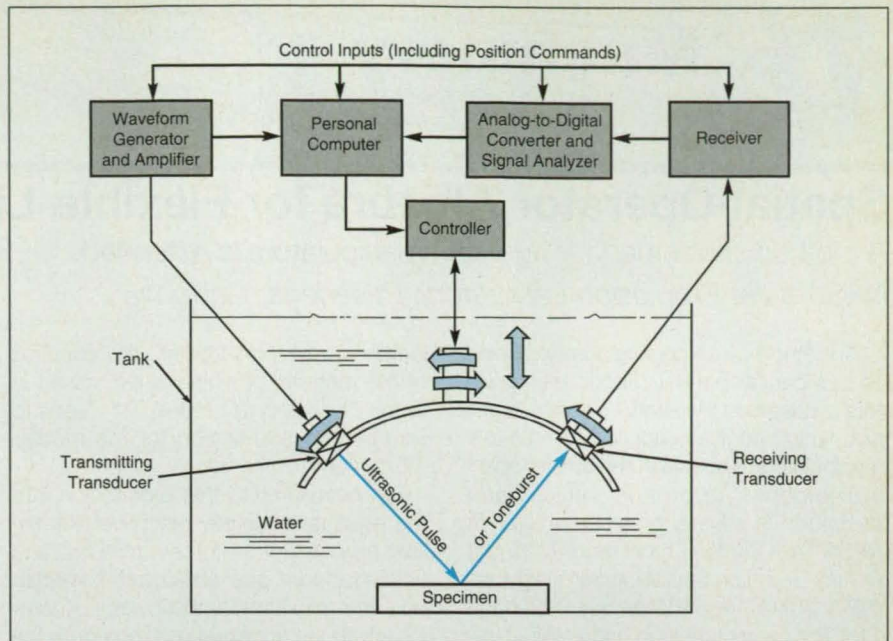

This **Ultrasonic Testing System** performs measurements that yield data on the five elastic constants of a specimen of orthotropic material.

also facilitates the cross-checking of measurements and computations.

This work was done by Yoseph Bar-Cohen of Caltech and Ajit K. Mal of

UCLA for NASA's Jet Propulsion Laboratory. For further information, write in 70 on the TSP Request Card. NPO-18908.

When the problem is nonlinear, the solution is VisSim™

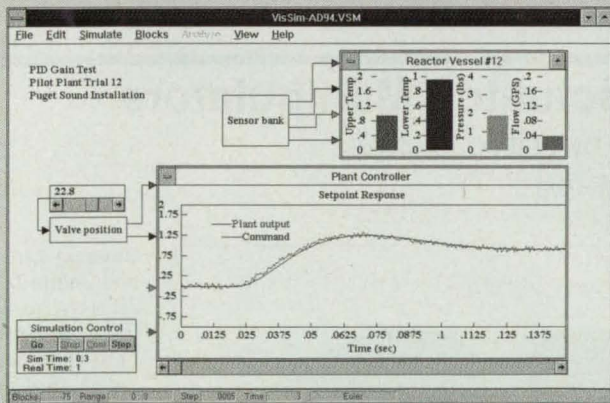

Change parameter values while the simulation runs and see the results instantly.

VisSim is the most powerful simulation software for modeling the behavior of complex, nonlinear systems, like industrial processes, servo systems, and drive systems. Its advanced visual interface lets you build system models more easily, shorten design cycles, and reduce prototyping costs. Your learning time is minimal.

VisSim runs on MS/Windows™, MS/WindowsNT™, and Unix®/X™ platforms.

Call today and see how VisSim can help solve your problems.

For a free working demo, call 508/392-0100.

VisSim companion software includes VisSim/Analyze™, VisSim/C-Code™, VisSim/Neural-Net™, and VisSim/RT™.

"VisSim [1.2] is powerful. RECOMMENDED."

Jerry Pournelle
BYTE Magazine
January, 1994

VisSim Features

- Visually programmed diagram language
- Hierarchical design
- 80+ built-in block functions
- Integrate custom blocks in C or Fortran
- Extensible toolbox libraries
- Nonlinear and linear
- Parameter optimization **NEW**
- Hybrid, continuous, and discrete multi-rate
- 7 integration methods for fixed step, adaptive step, and stiff systems
- Multi-input/multi-output state-space
- Multi-channel 20mA/10V real-time (opt.)
- DDE and ASCII file import/export
- Linearization, zero & pole finder, and root locus & Bode plots (opt.)
- Meters and dynamic bar graphs **NEW**
- Time history, FFT, XY plots, strip charts **NEW**

Visual Solutions
INCORPORATED

487 Groton Road
Westford, MA 01886
508/392-0100
508/692-3102 FAX

Australia/New Zealand: +61-3-866-1766
Belgium: +32-2-384-73-09
Brazil: +55-48-433-6348
Denmark/Scandinavia: +45-4-22-51-77
France: +33-1-42-46-00-42
Germany/Austria/Switzerland: +49-69-25-22-55
Israel: +972-3-491-922
Italy: +39-22-62-60-208

Japan: +81-3-3496-1544
Korea: +82-2-704-5378
The Netherlands: +31-16-505-74-17
Spain/Portugal: +34-3-217-44-56
South Africa: +27-12-66-34-500
Taiwan: +86-62-20-57349
UK/Ireland: +44-462-480-055



Spatial-Operator Algebra for Flexible-Link Manipulators

A method developed for rigid-link manipulators is extended.

NASA's Jet Propulsion Laboratory, Pasadena, California

A method of computing the dynamics of multiple-flexible-link robotic manipulators is based on the spatial-operator algebra, which originally applied to rigid-link manipulators. Aspects of the spatial-operator-algebra approach have been described in several previous articles in NASA Tech Briefs — most recently "Robot Control Based on Spatial-Operator Algebra" (NPO-17918), Vol. 16, No. 9, (1992) page 115. The present method unifies the analysis for the rigid- and flexible-link cases in a more-general version of the spatial-operator algebra that accommodates the complexity of the dynamics, yet promotes economy of representation and computation.

As explained more fully in the previous articles on this topic, the spatial operators are high-level representations of how forces, torques, velocities, and accelerations propagate from link to link along manipulator arms. In the extension of the spatial-operator algebra to manipulators with flexible links, each link is represented by a finite-element model: the mass of a flexible link is apportioned among smaller,

lumped-mass rigid bodies, the coupling of the motions of which is expressed in terms of vibrational modes. This leads to an operator expression for the modal-mass matrix of the link.

By incorporating this expression into the equations for the recursive (link-to-link) propagation of forces, torques, and accelerations, one obtains the spatial-operator algorithm for the inverse dynamics (given the accelerations, compute the forces and torques needed to produce them) of the manipulator. These equations include an operator equation for the mass matrix of the entire manipulator. This mass matrix can be computed by a composite-body-based recursive algorithm similar to the corresponding algorithm for a rigid-link manipulator.

The forward-dynamics problem is to compute the accelerations, given the forces and torques applied to the joints of the manipulator, and the solution requires the inverse of the mass matrix. For this purpose, an alternative factorization of the mass matrix has been derived. Each of

the factors in this factorization is invertible and can therefore be used in an operator equation for the inverse of the mass matrix. The recursive implementation of this operator equation leads to a recursive algorithm that solves the forward-dynamics problem.

The amount of computation required by the inverse- and forward-dynamics algorithms is approximately proportional to the number of links, resulting in significant computational savings for flexible systems with a large number of degrees of freedom.

This work was done by Abhinandan Jain and Guillermo Rodriguez of Caltech for NASA's Jet Propulsion Laboratory. For further information, write in 53 on the TSP Request Card.

This invention is owned by NASA, and a patent application has been filed. Inquiries concerning nonexclusive or exclusive license for its commercial development should be addressed to the Patent Counsel, NASA Resident Office — JPL [see page 20]. Refer to NPO-18499.

Algorithm for Control of Underactuated Manipulators

Complexity of underactuated systems is managed by unified analysis.

NASA's Jet Propulsion Laboratory, Pasadena, California

An algorithm for the improved control of underactuated multiple-link robotic manipulators has been developed via the spatial-algebra-operator approach. Aspects of this approach have been described in several previous articles in NASA Tech Briefs — most recently "Robot Control Based on Spatial-Operator Algebra" (NPO-17918), Vol. 16, No. 9 (1992), page 115. Heretofore most of the research and development in robotics have focused on fully-actuated manipulators, in which there is an actuator associated with each degree of freedom. An underactuated manipulator is one that has fewer actuators than it has degrees of freedom.

The concept of underactuated manipulators has greater significance than its modest name connotes: It has implica-

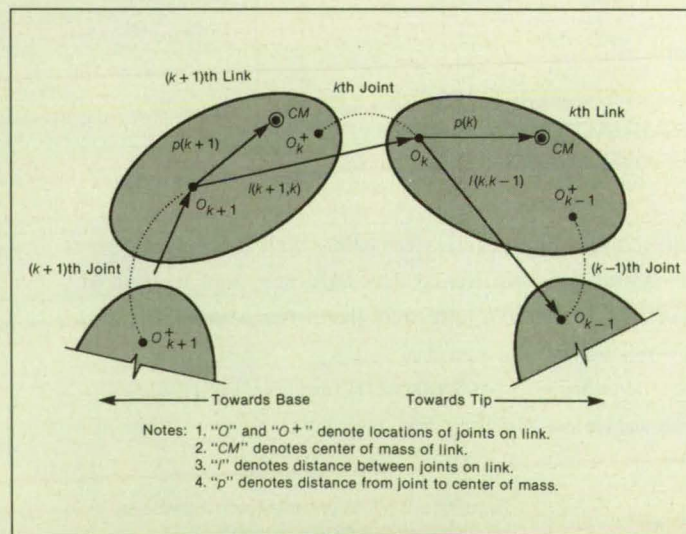

Several Links and Joints of a serial-link manipulator are shown here schematically. Spatial operators could also be used to analyze manipulators that have tree-like structures.

tions for fault-tolerant control, and many practical manipulators are underactuated. Examples include manipulators that have flexible joints and/or flexible links; space/underwater robots; manipulators that operate with some actuators that turned off because of failure or because of a need to conserve energy; manipulators that grasp objects loosely, and manipulators that grasp objects that have internal degrees of freedom (e.g., plungers, rollers).

Of course, the kinematics and dynamics of underactuated manipulators are more complicated than are the dynamics of fully actuated manipulators. The control problem is compounded by the fact that motion in some degrees of freedom can be totally or partly uncontrollable. As explained more fully in the previous articles on spatial-operator algebra, the spatial operators are so named because they

are high-level representations of the kinematics and dynamics that show how forces, torques, velocities, and accelerations propagate through space from link to link along the manipulator arms. The spatial-operator algebra provides a theoretical framework for the kinematical and dynamical analysis and modeling of multiple-link robotic manipulators in general, and it accommodates the complexity of underactuated manipulators.

The development of the algorithm for control of an underactuated manipulator begins with the use of the spatial-operator algebra to derive equations for the generalized Jacobian, mass matrix, and dynamical equations. A projection operator that characterizes the relationship between corresponding quantities for partly and fully actuated manipulators was identified. Efficient recursive algorithms for the

inverse dynamics (given the accelerations, find the forces and torques needed to produce them) and the forward dynamics (given the forces and torques, find the accelerations) were derived. Showing that these algorithms are hybrids of the inverse- and forward-dynamics algorithms is one of the important contributions of the spatial-operation approach.

This work was done by Abhinandan Jain and Guillermo Rodriguez of Caltech for NASA's Jet Propulsion Laboratory. For further information, write in 109 on the TSP Request Card.

This invention is owned by NASA, and a patent application has been filed. Inquires concerning nonexclusive or exclusive license for its commercial development should be addressed to the Patent Counsel, NASA Resident Office—JPL [see page 20]. Refer to NPO-18498.

Permanent-Magnet Meissner Bearing

Stacked Permanent magnets provide spatially alternating end fields in a stable configuration.

Marshall Space Flight Center, Alabama

The figure illustrates a rotary permanent-magnet Meissner bearing. Meissner bearings are so named because they are based on the Meissner effect — the exclusion of a magnetic field from the interior of a superconductor.

Cylindrical permanent magnets with axial magnetization are stacked coaxially on the rotor with alternating polarity. Typically, rare-earth magnets are used. The magnets are machined and fitted together to form a conical outer surface. Conical pressure plates face the conical surfaces of the rotor, separated from the rotor by small gaps. The facing surfaces of the pressure plates are covered by a material that is superconductive at and below the temperature of liquid nitrogen. Each pressure plate is part of a chamber that is kept full of liquid nitrogen.

The left liquid-nitrogen-chamber-and-pressure-plate assembly is held in a fixed position. The right liquid-nitrogen-chamber-and-pressure-plate assembly is free to translate a short distance axially, and is pressed toward the left by a set of springs. Because of the Meissner effect, the alternating-polarity magnetic field at the ends of the magnets cannot penetrate the pressure plates. Instead, it becomes squeezed into the gaps between the conical surfaces of the rotor and the pressure plates.

Any increase in load that tends to push the rotor laterally or axially toward a pres-

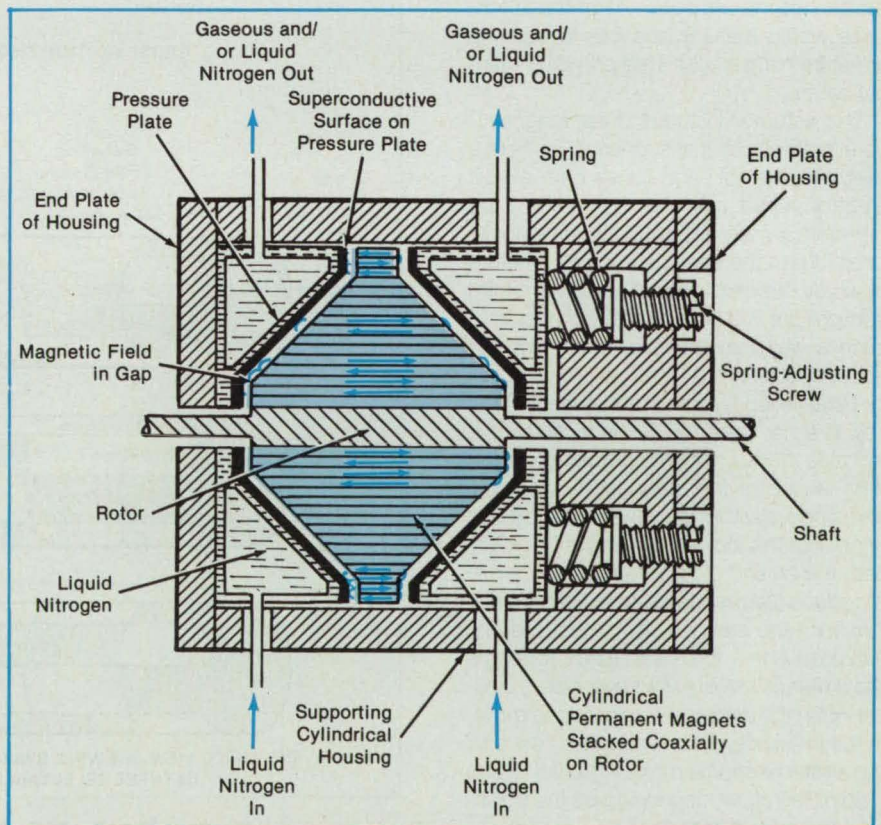

This Permanent-Magnet Meissner Bearing features an inherently stable, self-centering conical configuration.

sure plate squeezes the magnetic field further, resulting in a compensating increase in magnetic pressure in the gap. Thus, the magnetic field acts as a cushion between the rotor and the pressure plates. The conical configuration of the facing rotor and pressure-plate surfaces

ensures an inherently stable, axially and radially centering magnetic-levitation force field. The bearing can be made stiffer or less stiff by selection of the magnets, springs, and spring adjustments.

This work was done by Glen A. Robertson of **Marshall Space Flight**

Center. For further information, write in 50 on the TSP Request Card.

Inquiries concerning rights for the commercial of this invention should be addressed to the Patent Counsel, Marshall Space Flight Center [see page 20]. Refer to MFS-28603.

Linear Electromagnetic Actuator With Manual Override

The armature and magnets can be hermetically sealed.

Marshall Space Flight Center, Alabama

The figure illustrates various aspects of a conceptual permanent-magnet-assisted electromagnetic linear actuator that could be used, for example, to set the axial position of a metering component in a valve. As in other linear electromagnetic actuators, the position of the armature can be controlled by applying a current of appropriate magnitude and polarity to electromagnet coils. One notable feature of the actuator is an external pole-piece subassembly that could be swiveled manually about the axis of linear motion (which is also the axis of cylindrical symmetry) to vary the distribution of magnetic flux in such a way as to override the aforementioned electrical position control. The small magnetic flux that extends to outside the main body of the actuator could be monitored to determine the position of the armature. All of these features would make it possible to seal the armature hermetically while providing manual control.

The actuator includes outer magnetic-core (pole) pieces that support fluxes from a magnet assembly and fluxes from a split electromagnet coil. The fluxes from the permanent magnets circulate in opposite directions in the core pieces and armature at axially opposite ends. The halves of the split coil are wound and interconnected in such a way that the flux induced by the coil circulates in one direction, with a polarity established by that of the current in the coil. In either case, the flux induced by the coil aids the flux from the permanent magnets in one of the magnetic-flux circuits and opposes it in the other. The net flux generates magnetomotive forces in the air-gap at each end of the armature, of a sense to reduce the respective gap. Without any flux from the coil, the permanent-magnet flux produces a force that tends to toggle the armature toward whichever pole is closest when the armature is released to move. In the presence of flux induced by the coil, the armature can be made to stroke to one pole or the other, depending on the polarity of the current in the coil.

The midlength outer-pole-piece subassembly is the one that can be swiveled

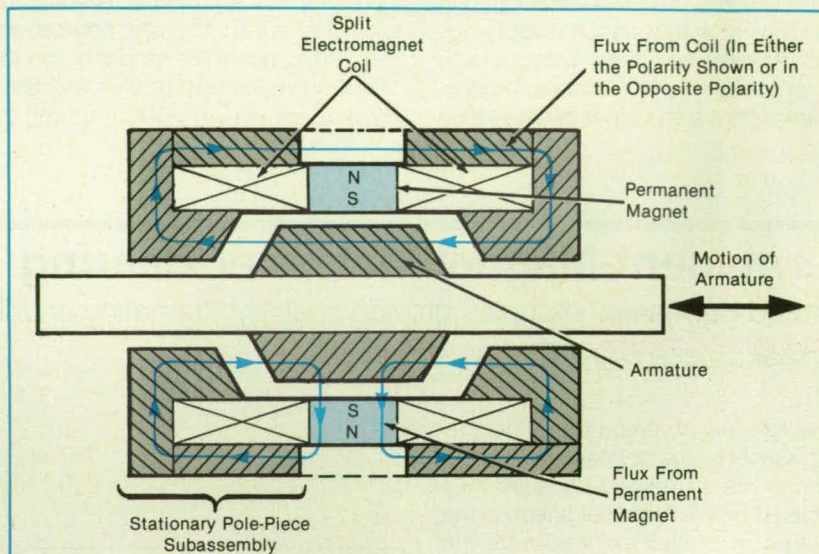

CROSS SECTION SHOWING FLUX PATHS

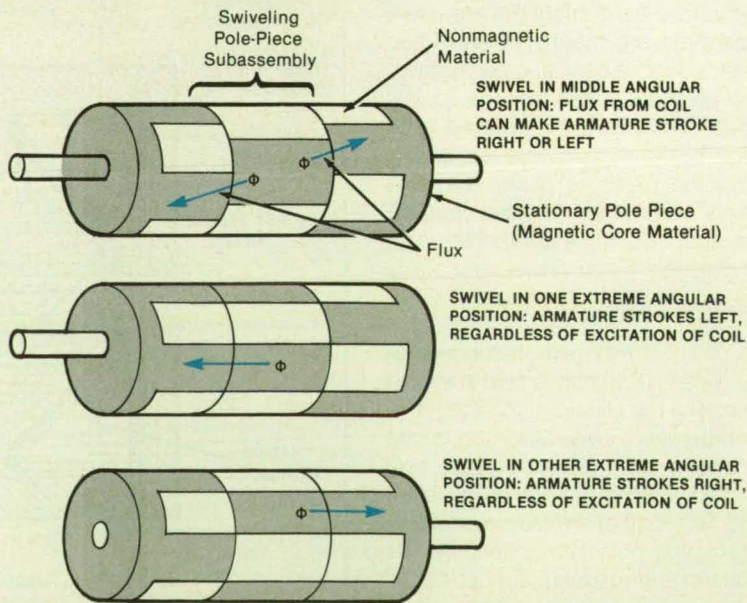

SIMPLIFIED VIEW SHOWING SWIVELING POLE-PIECE SUBASSEMBLY IN THREE SELECTABLE ANGULAR POSITIONS

The Distribution of **Magnetic Flux Could Be Controlled** electrically (by application of current to the split electromagnet coil) or manually (by setting the angular position of the swiveling pole-piece subassembly) to toggle the armature to the leftmost or rightmost position.

to effect manual override. Its effect on the distribution of magnetic flux is so great that swiveling it from one extreme axial position to the other causes the armature to toggle from one extreme linear position to the other, even when no electrical current is applied. When the swiveling sub-assembly is in the middle (nominal or null) angular position, the position of the armature can be controlled by applying the electrical current of appropriate magnitude and polarity. If the swiveling subassembly is maintained at either extreme angular position, the electrical current cannot generate sufficient flux to overcome the prevailing flux condition. The armature remains in

the position commanded by manual override.

The position-monitoring function is available when the swivel is in the middle angular position. A compasslike device placed just outside the main body of the actuator can indicate the direction of prevailing flux and thus the position of the armature. Alternatively, the position of the armature can be deduced from the outputs of Hall-effect devices or other sensors that measure fringing magnetic fields at small gaps near opposite ends of the stationary pole-piece subassembly.

This work was done by Stephen G. Abel of Allied-Signal Aerospace Co. for Marshall

Space Flight Center. No further documentation is available.

Title to this invention has been waived under the provisions of the National Aeronautics and Space Act [42 U.S.C 2457(f)], to the Allied-Signal Aerospace Co. Inquiries concerning licenses for its commercial development should be addressed to: Joseph R. Black; Allied-Signal Aerospace Company; 111 South 34th Street; P. O. Box 5217; Phoenix, AZ 85010.

Refer to MFS-28678, volume and number of this NASA Tech Briefs issue, and the page number.

Self-Calibrating, Variable-Flow Pumping System

Accurate flows are needed for mixing.
Marshall Space Flight Center, Alabama

A pumping system provides accurate, controlled flows of two chemical liquids that are to be mixed in a spray head and that react to form rigid or flexible polyurethane or polyisocyanurate foam. It is compatible with currently used polyurethane-based coating materials and gas-bubble-forming agents (called "blowing agents" in the industry) and is expected to be compatible with materials that will be used in the near future. For example, it can handle environmentally acceptable substitutes for chlorofluorocarbon foaming agents.

The system produces a fixed or variable rate of output of each liquid as required. Fixed output is defined and established in a closed-loop control scheme in which the sensed and controlled output is either the speed of the pump or the rate of flow; the system strives to maintain either at a designed fixed value (set point). Variable output can be established by use of a programmed table of up to 700 set points, either entered by the user or computed from a polynomial relationship. Alternatively, variable output can be obtained by use of an analog voltage from an external control device or derived from a computation; this method gives closed-loop control in real time.

The system (see figure) includes, for each liquid, a pressurized tank, metering and pressurizing pumps, meters, servomotors, and encoders. The metering pumps are of the variable-displacement, multielement, axial-piston type, selected for accuracy and reliability in an industrial environment. The pump housings were modified so that residues of the pumped chemicals can be flushed out at the end of a job or when

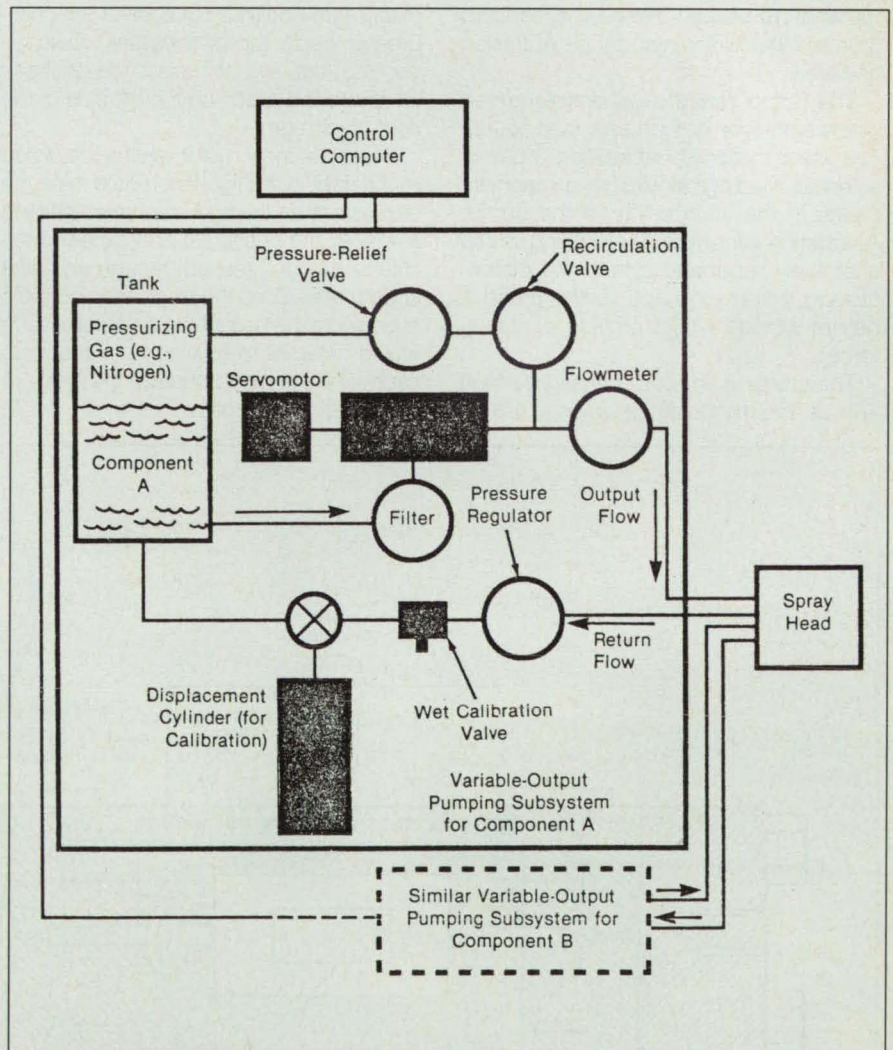

The **Variable-Output Pumping System** produces metered recirculating or nonrecirculating flows of two liquids (Component A and Component B) that are to be mixed in the spray head to make spray-on foam insulation.

materials are changed. The pump displacement can be varied to give an output range of 5 to 100 lb/min (2.3 to 45 kg/min).

A volumetric calibration subsystem includes electronically instrumented displacement cylinders that measure the flow in each component output stream. Periodically, a return flow of each stream is diverted to the calibration subsystem, where mechanically coupled optical en-

coders determine the resultant displacement of the cylinders. Controlled back pressure is applied to each displacement cylinder to prevent premature vaporization of the blowing agent and the consequent frothing that would distort the measurement. The automatic calibration ensures accurate mixing despite changes in pressure, temperature, and viscosity. It also makes it possible to use a wide variety of

materials in the spray equipment.

This work was done by Joe T. Walls of Martin Marietta Corp. for **Marshall Space Flight Center**. For further information, write in 54 on the TSP Request Card.

Inquiries concerning rights for the commercial of this invention should be addressed to the Patent Counsel, Marshall Space Flight Center [see page 20]. Refer to MFS-28662.

Hermetically Sealed Compressor

All moving parts are sealed within the compressor housing.

Lyndon B. Johnson Space Center, Houston, Texas

A proposed hermetically sealed pump would compress a fluid to a pressure up to 4,000 atm (400 MPa). The pump would employ a linear electric motor instead of a rotary motor to avoid the need for leakage-prone rotary seals. In addition, the linear-motor-powered pump would not require packings to seal its piston. The concept thus eliminates a major cause of friction and wear.

The pump would be a double-ended diaphragm-type compressor (see figure). The linear motor would include a pair of solenoid windings encircling a magnetic piston in the main cavity of the pump. Alternating currents in the winding would alternately repel and attract the piston, moving it from one end to the other. A pair of springs would provide centering forces.

The cavity of the pump would be filled with oil. The motion of the piston to the left

in the figure would create a low pressure on the left side of the diaphragm in the right heads. This would draw the diaphragm inward against the compressor body, thereby drawing the fluid to be compressed through an inlet check valve in the cavity in the right headplate. Once the diaphragm bottoms out against the compressor body, the oil pressure would go very low, drawing oil through the oil check valve into the space on the left side of the right diaphragm.

When the linear motor returns the piston to the right in the figure, it would raise the oil pressure on the right diaphragm, forcing it against the headplate and expelling the fluid to be compressed through an outlet check valve. Once the diaphragm bottoms out against the headplate, an oil relief valve would allow oil to flow back to the main cavity of the pump to equalize the pressure in the right end again. The cycle would

then repeat. While the right head would be drawing in low-pressure fluid, the left head would be discharging high-pressure fluid, and vice versa.

To allow for contraction or expansion of the oil with changes in temperature, the compressor body would contain a bellows. As the oil changes in volume, so would the bellows. It would thereby maintain the pressure in the main cavity near 1 atm (0.1 MPa).

This work was done by Mark T. Holtzapple of Texas A. & M. University for **Johnson Space Center**. For further information, write in 1 on the TSP Request Card.

In accordance with Public Law 96-517, the contractor has elected to retain title to this invention, covered by U. S. Patent number 5,106,274. Refer to MSC-21427, volume and number of this NASA Tech Briefs issue, and the page number.

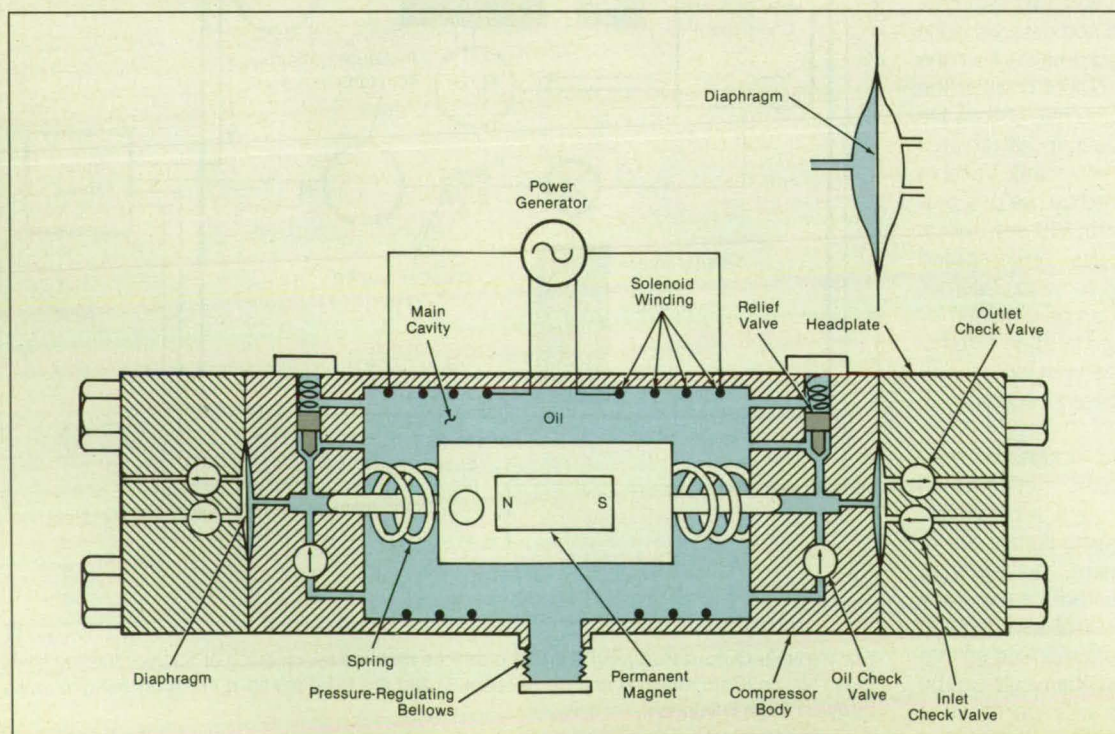

The Reciprocating Piston and its linear motor would be contained in a hermetically sealed housing. The unit was adapted from a nonhermetic commercial unit.



System Grows Single-Crystal Fibers

Single or multiple single-crystal fibers can be grown to various lengths.

Lewis Research Center, Cleveland, Ohio

The award-winning Melt Modulation™ system (see figure) produces single or multiple fibers of any of a variety of single-crystal materials in continuous or discrete lengths. The system was developed specifically to produce research quantities of fibers for strong, lightweight composite materials that can withstand high temperatures in aerospace applications. The system could also be used to grow such single-crystal materials as high-temperature superconductors and fiber-optic materials. Modifications could enable the system to apply conformal coats to fibers as they are being grown, producing fibers for a greater number of composites in which the coatings provide thermal and chemical compatibility between the fiber and matrix materials.

The fiber is produced from feed-rod stock that is introduced to a molten zone suspended between the feed rod and a single-crystal seed. The feed rod is flexible and continuous, made of a material of homogeneous composition and doped as needed for the intended application. The thermal energy to melt the feed rod is supplied by a laser beam focused onto and scanned across the molten zone.

The technique used to generate, focus, and control the laser energy is a major feature of the Melt Modulation™ system. The innovative beam-delivery technique provides thermal control that makes possible the sharp reduction of diameter from that of the feed rod to that of the grown fiber, thereby enabling shorter lengths of feed rod to yield greater lengths of fiber. The linear laser energy distribution produced by the Melt Modulation™ results in more laser energy input into larger cross sections and less energy into smaller cross sections. This energy distribution minimizes overheating and stabilizes the shape of the molten zone. The stabilized molten zone allows greater attenuation between the solidified fiber and the feed rod.

The rate of growth of fiber is governed by microprocessor control of motors on the fiber and feed-rod pull heads. The system can grow one fiber or several fibers simultaneously; five fibers have been grown simultaneously to a length greater than 2 m. Growth speeds in excess of 2 m/h have been achieved.

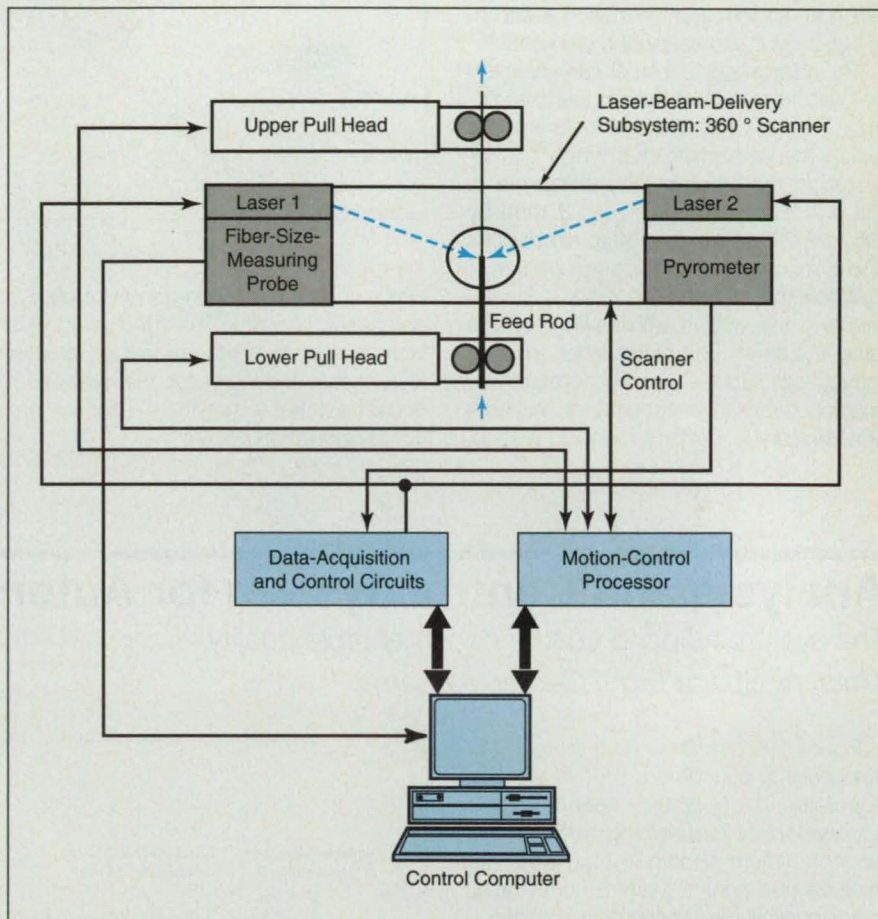

Single-Crystal Fibers that have superior properties are produced in this Melt Modulation™ fiber-growth system.

The thermal uniformity of the Melt Modulation™ process results in fibers without voids and with otherwise superior properties. For example, this system produced single-crystal fibers of sapphire that had tensile strengths of $5,385 \pm 896$ MPa at a temperature of 25°C , $1,517 \pm 262$ MPa at $1,000^\circ\text{C}$, and $1,043 \pm 228$ MPa at $1,200^\circ\text{C}$; in contrast, commercial sapphire fibers made by an edge-defined growth technique exhibited corresponding tensile strengths of only $2,434 \pm 503$ MPa, 724 ± 26 MPa, and 606 ± 54 MPa, respectively. Moreover, the edge-defined growth process involves a crucible and orifice that remain in contact with the molten material being grown. Such a contact can result in contamination of the melt and thus severely limits the number of materi-

als that can be evaluated for the development of new fibers. In contrast, no foreign material is placed in contact with the molten material in the Melt Modulation™ system, because in this system, the feed rod supports the melt. The Melt Modulation™ system is available commercially from Peachtree Scientific, Inc., and was recognized as one of the 100 most-significant technological developments of 1993 by R & D Magazine's "R & D 100" Award.

This work was done by Leonard Westfall of Lewis Research Center, Ali Sayir of Case Western Reserve University, and Wayne Penn of Peachtree Scientific, Inc. For further information, write in 37 on the TSP Request Card. LEW-15782.

Wire Stripper Holds Insulation Debris

A commercial tool is modified by attaching a small collection box to one of the jaws.

John F. Kennedy Space Center, Florida

An attachment to a standard wire-stripping tool catches bits of insulation as they are removed from electrical wire and retains them for proper disposal. The attachment prevents insulation particles from falling at random, contaminating electronic equipment and soiling the workspace.

The attachment is a small box mounted on one of the jaws of the stripper (see figure). The box has a single opening into which the wire protrudes when it is inserted in the stripper. The prototype of the box measures $1\frac{1}{2}$ in. (≈ 3.8 mm) by $1\frac{1}{8}$ in. (≈ 27 mm) in two of its dimensions and is made of Lexan™ polycarbonate.

When the stripper has cut the insulation and the wire is withdrawn from the jaws, the short tube of insulation thus removed falls into the box. By collecting insulation debris, the attachment makes it unnecessary to perform manual cleanup,

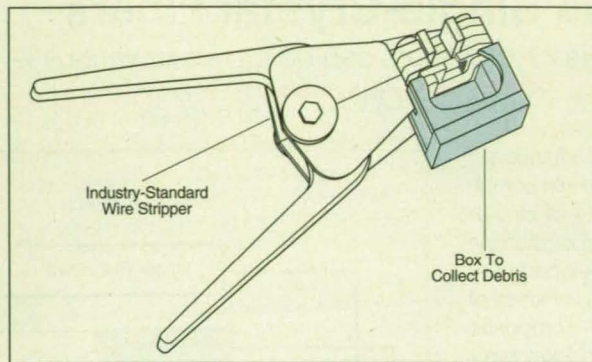

The **Small Box on One Jaw of the Wire Stripper** catches insulation clippings and holds them until it is intentionally emptied. One wall of the box is cut away in this view to show internal details.

which is time consuming and not always completely effective. The attachment thus increases productivity, promotes greater cleanliness, and increases the reliability of equipment that is sensitive to contamination by insulation debris.

This work was done by Allen D. Cook, Henry S. Morris, and Laverne Bauer of Lockheed Space Operations Co. for Kennedy Space Center. No further documentation is available. KSC-11658.

Analysis and Control System for Automated Welding

The system helps to ensure documentable quality.

Marshall Space Flight Center, Alabama

Figure 1 illustrates an automated variable-polarity plasma arc (VPPA) welding apparatus that operates under electronic supervision by the welding analysis and control system shown in Figure 2. The analysis and control system performs all major monitoring and controlling functions. It acquires, analyzes, and displays weld-quality data in real time and adjusts process parameters accordingly. It also records pertinent data for use in post-weld analysis and documentation of quality.

The motion of the torch in three dimensions is provided by the weld fixture and drive mechanism, the cross-slide assembly, and the axial-slide assembly. The torch can also be rotated by a mechanism (not shown) in the torch-mounting assembly. The motors in all three mechanisms are controlled by the host data processor via the motor-control interface and motor controller.

The stereoscopic-vision seam-tracker sensor head acquires image data for tracking seams, including tight butt joints that have not yet been welded and thus exhibit minimal profiles. The profiler sensor head acquires image data for computing cross-sectional profiles of the weld bead. The profiler can be used (1) in place of or in

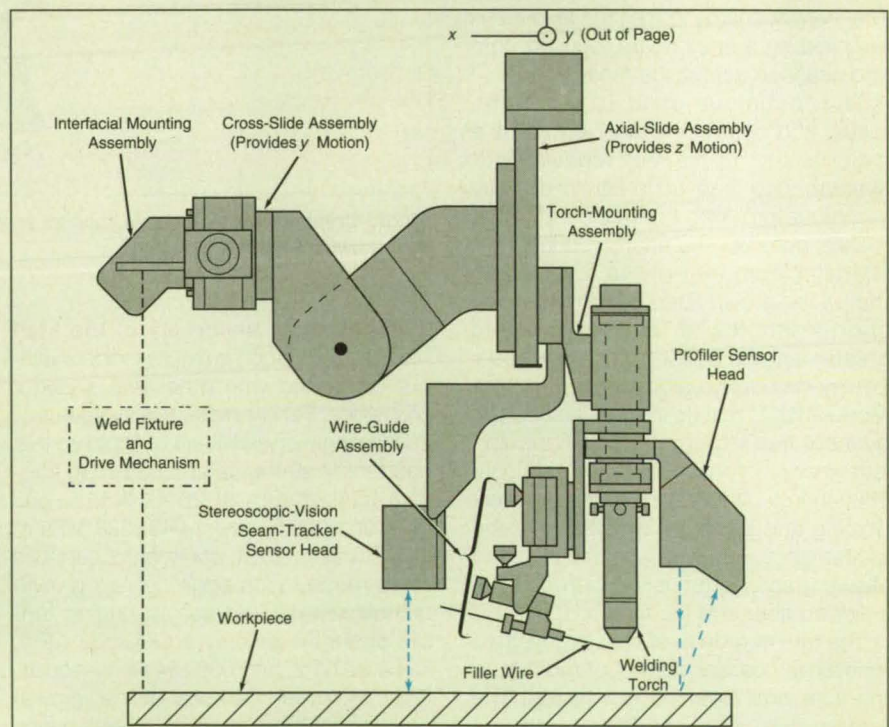

Figure 1. This **Welding Apparatus** operates under electronic control by the system of Figure 2. Figure 2. The **Welding Analysis and Control System** includes optoelectronic sensors and data processors that provide feedback control of the welding process plus data on the quality of the weld.

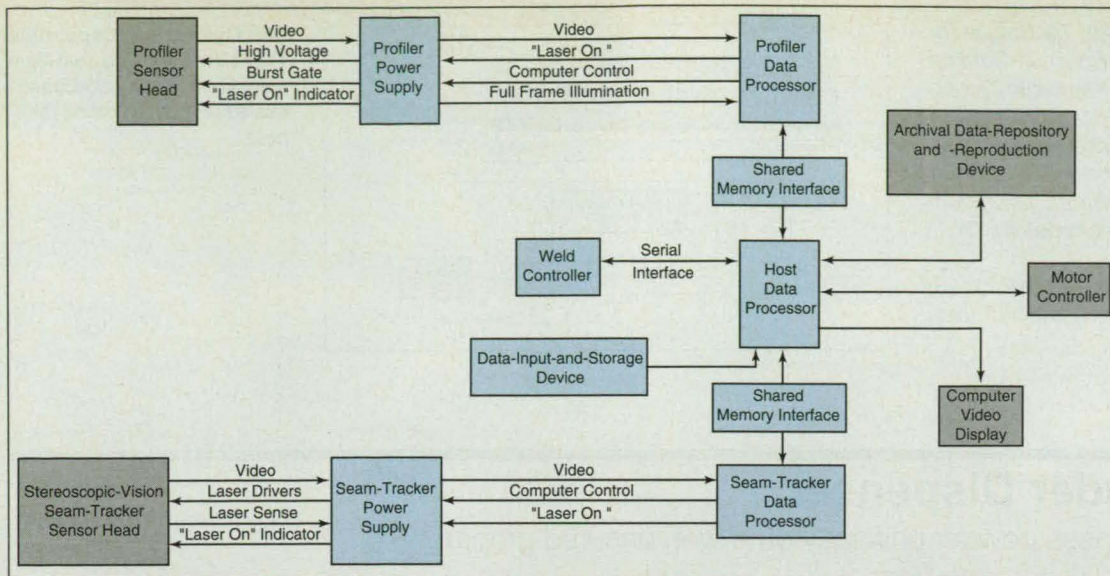

Figure 2. The **Welding Analysis and Control System** includes optoelectronic sensors and data processors that provide feedback control of the welding process plus data on the quality of the weld.

addition to the seam tracker as a preweld sensor for tracking a grooved, unwelded or partially welded seam, or (2) to obtain the profile and specified geometrical parameters of a weld bead.

The output of the profiler can be used as feedback in a feedback control loop to adjust the parameters of the welding process (e.g., the welding-torch current and the distance between the torch and the workpiece). Occasionally, direction of the centerline of the jet of plasma from the welding torch abruptly changes by a few degrees, causing asymmetry in the weld bead. The profiler detects this asymmetry, thus providing a feedback signal that can be used to rotate the torch to restore symmetry.

The seam-tracker and profiler data processors communicate with the host data processor via a shared memory interface, which is a region of memory to which the processors all have access as though it resides in whichever processor is interacting with it at the moment. In addition to performing tracking and other feedback-control functions, the host data processor communicates with an archival data-repository and -reproduction device, in which all critical process parameters and data on the operations of the welding apparatus are recorded for selective review after completion of the welding process. Such a review can substitute for destructive testing to determine the quality of the weld.

This work was done by Bradley W. Powell, Ivan A. Burroughs, Larry Z. Kennedy, Michael H. Rodgers, and K. Wayne Goode of Applied Research, Inc., for Marshall Space Flight Center. For further information, write in 42 on the TSP Request Card.

In accordance with Public Law 96-517, the contractor has elected to retain title to this invention. Inquiries concerning rights for its commercial use should be addressed to: Applied Research, Inc.; 6700 Odyssey Drive; Research Park West; Huntsville, AL 35806.

Refer to MFS-26241, volume and number of this NASA Tech Briefs issue, and the page number.

Capacitive Measurement of Coating Thickness on Carbon Fibers

Capacitance measured with a cylindrical transducer varies linearly with thickness.

Langley Research Center, Hampton, Virginia

A technique for gauging the coating thickness during prepreg processing of carbon fibers has been developed. The technique is based on measurement of the capacitance of a cylindrical condenser through which a bundle of prepregged fibers is passed axially. Empirical results indicate that the capacitance is linearly related to the thickness of the polymer coat on the fibers in the bundle. A capacitive transducer has been used successfully to measure the thickness of polymer coats on several test bundles of fibers under static conditions.

The transducer (see figure) includes an aluminum cylinder containing a polytetrafluoroethylene tube. A bundle of about 3,000 polymer-coated graphite

fibers is passed axially through the transducer. The aluminum cylinder thus constitutes an outer electrode of a cylindrical capacitor; the graphite fibers act collectively as an inner cylindrical electrode; and the polytetrafluoroethylene tube, the intervening layer of air, and the polymer coat on the fibers act collectively as the capacitor dielectric medium.

In experiments, the capacitive transducer was employed to sense a stationary axially positioned bundle of 3,000 polymer-coated graphite fibers. The capacitance was measured by use of a precise digital capacitance bridge capable of resolving ± 0.1 pF. As theorized, the capacitance of the gauge was found to be related linearly to the weight of the

polymer coat on the fiber. If this transducer is calibrated by use of known values of polymer loading on the graphite fibers, it can provide real-time sensing of the thickness of the polymer coat. However, the measured capacitance shows considerable scatter at lower coating levels. For real-time monitoring at these low levels, a time-averaging filter should be used. This technique can lead to better control of processing variables to optimize properties of carbon-filled composites.

This work was done by Abe Eftekhari of Analytical Services and Materials, Inc., and John J. Chapman of Langley Research Center. Further information may be found in NASA TM-101682 [N90-

14533/TB], "A Capacitive Technique for Real-Time Monitoring Polymer Coating Thickness on Carbon Filaments During Prepregging Process."

Copies may be purchased [prepayment required] from the NASA Center for AeroSpace Information, Linthicum Heights, Maryland, Telephone No. (301) 621-0394.

Rush orders may be placed for an extra fee by calling the same number. LAR-14396.

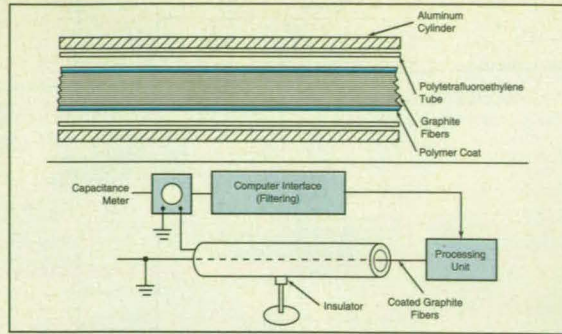

The **Cylindrical Capacitive Transducer** yields real-time measurements of capacitance related directly to coating thickness.

Resin-Powder Dispenser

This device dispenses powder uniformly onto wet, uncured prepregs.

Langley Research Center, Hampton, Virginia

A resin-powder dispenser is used at NASA's Langley Research Center for processing of composite-material prepregs. The dispenser evenly distributes the powder (resin polymer) and other matrix materials in powder form) onto wet uncured prepregs. Previously, resin powder was placed onto prepregs manually during layup, before molding. In the manual method, powder could not be placed on a wet uncured prepreg: it could be placed on only one side of the prepreg, and the distribution of powder was uneven. The dispenser applies a predetermined amount of resin solid in powder form onto a fiber tow during the prepreg operation.

The dispenser includes a plastic bottle with a funnel shape on one end and a closing top on the other end, as shown in the figure. A small motor is attached to the closing top end. A shaft attached to the motor extends through a nipplelike piece that fits onto the funnel end. The motor turns the shaft, causing the powder to be dispensed through the nipple. The size of the hole in the nipple piece determines the amount of powder that is dispensed. There are several interchangeable nipples with diameters ranging from roughly 0.15 to 0.20 in. (3.8 to 5.1 mm).

The resin-powder dispenser provides versatility in the distribution of solid resin in the prepreg operation. Its use enables the powder to be distributed evenly, to be placed on a wet uncured prepreg, and to be placed on the top or bottom of the prepreg or between prepreg fibers.

The resin powder dispenser can be used wherever there is a requirement for an even, continuous distribution of a small amount of powder.

This work was done by Clarence E. Standfield of **Langley Research Center**. No further documentation is available. LAR-14589.

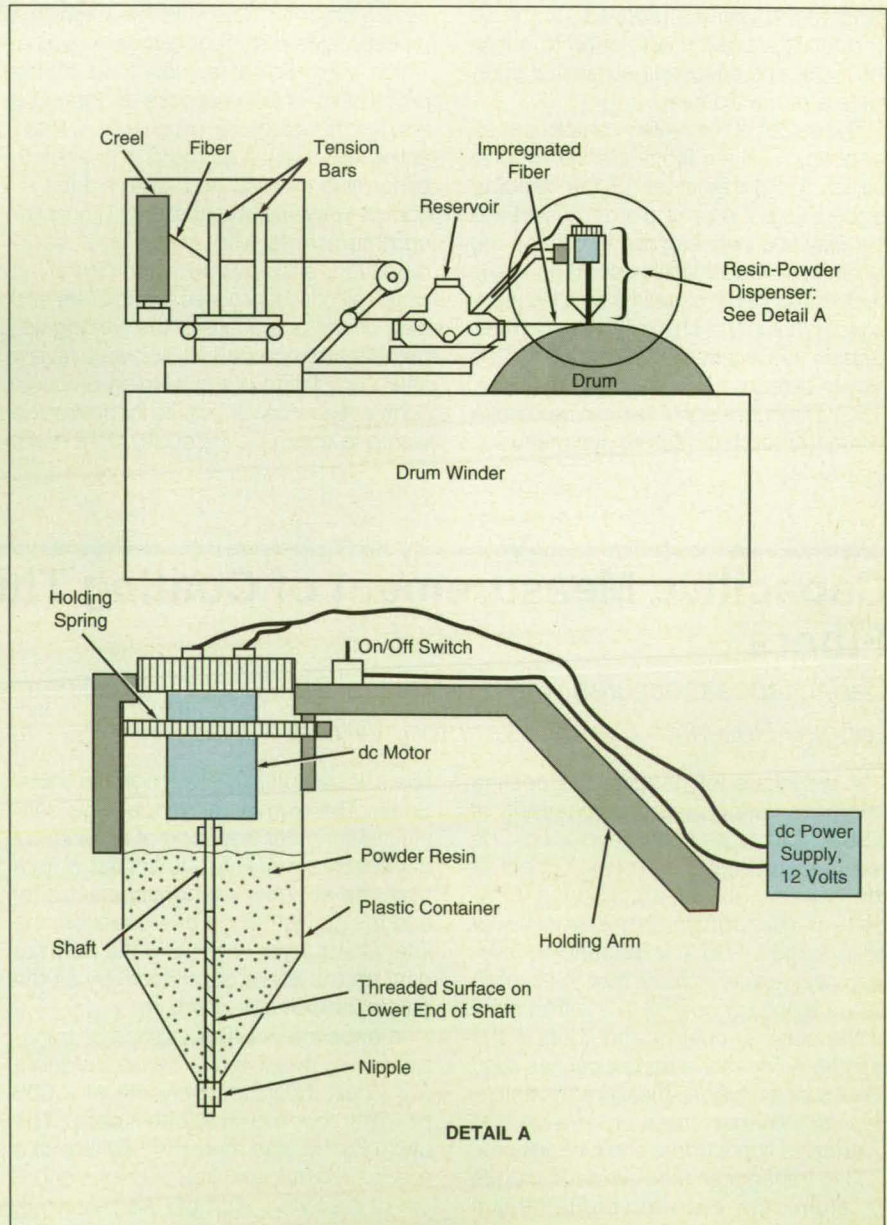

Resin Powder Is Metered through the opening in the nipple by a rotating threaded shaft.

Multiple Pages Intentionally Left
Blank



Mathematics and Information Services

Method of Predicting Size of Software Under Development

A metric called "function mass" has been proposed.

NASA's Jet Propulsion Laboratory, Pasadena, California

A method of estimating the size and complexity of a large computer program under development is based on a metric called "function mass." "Function Mass" is a simplification of Demarco's "function bang" metric. The size of a completed program is usually expressed in terms of the number of lines of code (SLOC), which has been shown in previous research to be highly correlated with the amount of development effort and is therefore an important predictor of development cost. The proposed method of estimating the ultimate size of a program is an intermediate product of continuing research on the estimation of size and the structured analysis of developmental software. This research is motivated largely by the need to refine estimates of size during the planning phases of software-development projects: heretofore, estimates have often been high or low by factors as large as 2.

The derivation of the present method begins with a modern system-development structured approach to identification and mathematical modeling of the requirements that the software must satisfy. The requirements are typically represented in a data-flow diagram (see figure) as a hierarchical set of functions represented by bubbles, with interfaces between bubbles shown as data-flow arrows. Higher-level bubbles encapsulate sets of lower, more-detailed functions, and this hierarchical scheme continues down to the level of modules, which are somewhat loosely defined but can be considered as "black boxes" that perform cohesive sets of functions that can be executed by subprograms or subroutines.

Implicit in such a hierarchical decomposition scheme is the assumption that the combination of (1) the cumulative set of all lowest-level bubbles in a data-flow diagram and (2) the cumulative set of inputs and outputs as specified in a data dictionary completely specifies the software system to be developed. The lowest-level bubbles are described in terms of elementary functions that, collectively, describe the function performed by the bubble. Therefore, the size of the software can be represented as $S = S(B, I, O)$, where B is the number of bubbles at the lowest level, I is the number of inputs

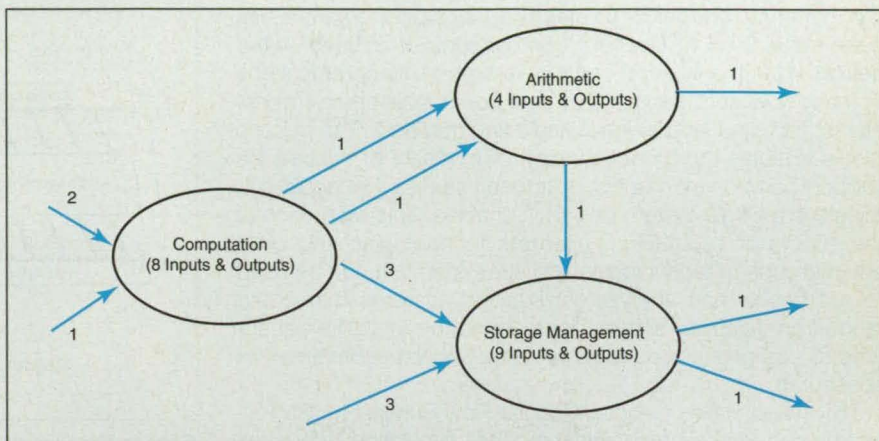

This **Portion of a Data-Flow Diagram** contains three nodes represented as bubbles, each labeled according to its functional classification. The number next to each arrow denotes the number of tokens transferred along the corresponding link between nodes.

needed by the bubbles, and O is the number of outputs generated by the bubbles. The parameters I and O are measured at the lowest level at which they are defined in the data dictionary.

One matter of concern in this approach is the leveling problem, which pertains to the differences among bubbles with regard to the granularity of the decomposition. A data-flow diagram produces a hierarchical functional decomposition such that a level i bubble encapsulates the cumulative set of functions at level $i + 1$. The basic guideline has been to continue breaking out the functionality until some metric of the size of a bubble is approximately equal for all bubbles or until the average has reached a minimum. This is often not practical because there is often not enough time and information to do a complete analysis when an estimate of cost must be made. Instead, in the present method, the relative size of a bubble is represented approximately by the number of requirements (R) associated with it. R is then used as the metric of size in the hierarchical decomposition.

Another important concept in the present method is that of the structural complexity (SC), which is quantified on a scale of 1 to 12. The SC of a bubble is computed by an algorithm that starts at 1 and adds 1 for each positive answer to a set of 11 questions about the function(s) to be per-

formed by the bubble. For example, the first question is whether the input data must be kept in a specified order, and the fifth question is whether the precision of the computation is important.

In the foregoing context, the function mass (FM) is defined in functional form; namely,

$$FM = FM(S, SC)$$

where

$$S = S(B, I, O, R)$$

The precise functional forms of FM and S are not yet clear, and three tentative forms have been tested with respect to ability to predict SLOC:

- (1) $FM = \ln(I + O) \cdot R \cdot SC$
- (2) $FM = (I + O) \cdot R \cdot SC$
- (3) $FM = (I + O)^a \cdot R^b \cdot (SC)^g$

where a , b , and g are obtained by statistical fits to information about real software development tasks. The results of the tests found that these functions are statistically significant measures of SLOC. The software size metric "function mass" is currently being used to evaluate the size and development costs of subsystems of the Deep Space Network.

This work was done by Jairus M. Hihn and Subramanyam K. Murthy of Caltech for NASA's Jet Propulsion Laboratory. For further information, write in 56 on the TSP Request Card. NPO-18846.



Life Sciences

Mathematical Modeling of Life-Support Systems

A generic model represents biological, physical, and chemical functions.

NASA's Jet Propulsion Laboratory, Pasadena, California

A generic hierarchical model of a life-support system has been developed to facilitate comparisons of options in the design of such a system. The model represents combinations of interdependent subsystems that could support microbes, plants, fish, and land animals (including humans). The generic model enables rapid configuration of a variety of specific life support component models for tradeoff studies that could culminate in a single system design. It enables rapid evaluation of the effects of substituting alternate technologies and even entire groups of technologies and subsystems. It can be used to synthesize and analyze life-support systems that could range from relatively simple, nonregenerative units like aquariums to complex closed-loop systems aboard submarines or spacecraft.

The model, called Generic Modular Flow Schematic (GMFS), can be coded in such chemical-process-simulation languages as Aspen Plus and can be expressed as a three-dimensional spreadsheet. With the help of the GMFS, one can optimize a life-support system in terms of a prescribed total weight, total power requirement, or total cost. An extension of an earlier

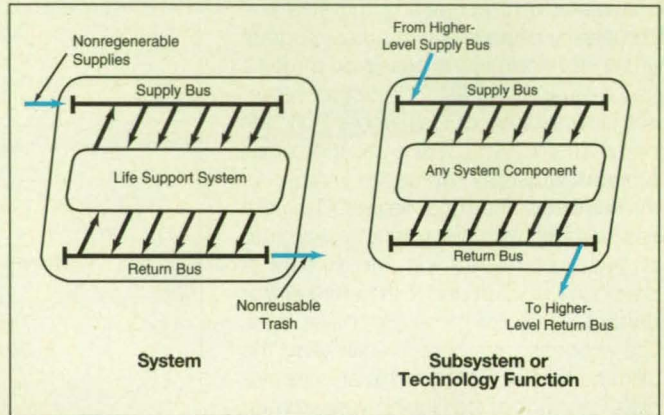

Generic Modules interconnected by supply and return buses are used to represent both the entire system and its subsystems.

model that represented physical and chemical processes only, the updated GMFS also represents biological processes.

The GMFS has a top-down hierarchical, modular structure (see figure), within which modules are connected to each other via bus lines for flows of materials and heat; only minimal functional overlap among modules is allowed. The overall hierarchical structure is divided into four levels, as follows:

- Level 0 represents the overall life-support system and its interfaces with the outside world. A description of level 0 would include the weight, volume, and other parameters of the entire system and the flows of heat and material between the system and the outside world.

- Level 1 breaks the system down into subsystems for humans, plants, aquaculture, microbes, and animals. For example, a subsystem for humans could include a habitat with associated temperature and humidity controls, air-revitalization equipment, and water-treatment equipment. Each subsystem would be described in terms of its weight, volume, and inflow and outflow of heat and materials.

- Level 2 breaks the subsystems down into functional elements. Each element is generic so that choices from among a variety of technologies can be made. As in the two higher levels, each functional element is regarded as a module that can be described in terms of its weight, volume, and inflows and outflows of heat and materials.

- Level 3 breaks the functional elements down into actual hardware. This level is nongeneric in that the hardware modules represent choices of specific technologies. Hardware items would be listed and, as in the three higher levels, treated as modules that can be described in terms of their weights, volumes, and inflows and outflows of materials and heat.

This work was done by Panchalam K. Seshan, Balasubramanian Ganapathi, Darrell L. Jan, Joseph F. Ferrall, and Naresh K. Rohatgi of Caltech for NASA's Jet Propulsion Laboratory. For further information, write in 23 on the TSP Request Card. NPO-18889.

SALI - 1700°C The Leading Hot Face Insulation

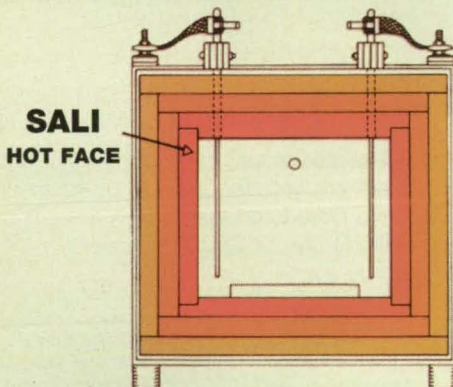

- Rapid Cycle Furnaces
- Systems for Lab & Production Sizes
- Best Hot Strength
- Low Conductivity
- Chemical Resistance
- Standard/Custom Designs



ZIRCAR PRODUCTS INC.
110 N. Main St. - PO Box 458
Florida, New York 10921-0458
(914) 651-4481 • Telex 996608
FAX (914) 651-3192

Call • Fax • or Write
For more information.
Ask for a Sales Engineer or
Technical Bulletin #ZPI-308

Books & Reports

These reports, studies, and handbooks are available from NASA as Technical Support Packages (TSPs) when a Request Card number is cited; otherwise they are available from the NASA Center for Aerospace Information.



Electronic Components and Circuits

Milliwatt Electric Power Sources Would Last for Years

A report discusses the design of proposed radioisotope thermoelectric generators, each of which would produce about 30 mW of electric power for decades, would fit in a package about the size of a D cell, and would have a mass of only 70 g. These small sources could be distributed around a small spacecraft to replace a centralized power plant. They could also energize the new generation of smaller, cheaper autonomous instruments, landers and microrovers.

This work was done by Arthur Chmielewski, Alexander Borshchevsky, and Cronin Vining of Caltech for NASA's Jet Propulsion Laboratory. To obtain a copy of the report, "Milliwatt Isotope Power Source for Microspacecraft," write in 12 on the TSP Request Card. NPO-19042.



Mathematics and Information Sciences

Normalization of Thermal-Radiation Form-Factor Matrix

A report describes an algorithm that adjusts the form-factor matrix in the TRASYS computer program, which calculates intraspacecraft radiative interchange among the various surfaces and environmental heat loading from sources such as the sun. The adjustments performed by the algorithm are intended to compensate for errors in the form factors, which are computed from simplified geometric models and used in computing flux-

es of heat between nodes in simplified thermal mathematical models.

This work was done by Glenn T. Tsuyuki of Caltech for NASA's Jet Propulsion Laboratory. To obtain a copy of the report, "TRASYS Form Factor Matrix Normalization," write in 25 on the TSP Request Card. NPO-18921.



Materials

Fingerprinting of Materials

A collection of three reports surveys the emerging technology of chemical fingerprinting, which can be defined, loosely, as the systematic application of modern methods of analysis to determine the elemental or molecular compositions of materials, measure the relative amounts of constituents of materials, and/or measure other relevant properties of materials. Chemical fingerprinting can include, for example, (1) the use of such instrumental chemical-analysis techniques as Fourier-transform infrared spectroscopy, high-performance liquid chromatography, nuclear magnetic resonance, and x-ray fluorescence spectroscopy; (2) the use of statistical techniques to optimize the acquisition and interpretation of data from instruments; and (3) the use of data-base-management techniques to store the acquired data and to identify the material under study by comparison of the acquired data with "signature" data on file.

This work was done by Gary L. Workman of the University of Alabama in Huntsville for Marshall Space Flight Center. To obtain copies of the reports, "Fingerprinting of Materials," "Chemical Fingerprinting — An Important TQM Tool for Control of Materials," and "Fingerprinting of Materials Technical Supplement," write in 58 on the TSP Request Card. MFS-27311.



Mechanics

Recent Developments in Theory of Balanced Linear Systems

A report presents a theoretical study of some issues of controllability and observability of a system represented by a linear, time-invariant mathematical model of the form

$x = Ax + Bu$, $y = Cx + Du$, $x(0) = x_0$ where x is an n -dimensional vector that

represents the state of the system; u is a p -dimensional vector that represents the control input to the system; y is a q -dimensional vector that represents the output of the system; n, p , and q are integers; $x(0)$ is the initial (zero-time) state vector; and the set of matrices (A, B, C, D) is said to constitute the state-space representation of the system. One example of such a system is a structure that can vibrate and that is equipped with vibration sensors and/or actuators that could be connected with a control system to measure and/or suppress vibrations.

This work was done by Wodek Gawronski of Caltech for NASA's Jet Propulsion Laboratory. To obtain a copy of the report, "Reduction and Assignment of Systems and Structures," write in 85 on the TSP Request Card. NPO-18753.



Fabrication Technology

Magnetic Subassembly for Directional-Solidification Furnace

A report describes the initial phase of development of a directional-solidification furnace that would grow nearly perfect single-crystal ingots of semiconductor materials in microgravity. The furnace assembly would include magnets: Lorentz force caused by the interaction between the magnetic field and convection currents in the electrically conductive melt would suppress the convection currents. (Even the minute accelerations of a spacecraft in adjustments of its orbit and attitude can give rise to residual convection, which adversely affects the homogeneity and structure of a solidifying crystal.)

The report discusses primarily the magnetic subassembly, which would be built with permanent magnets instead of electromagnets to keep the weight and power consumption as low as possible.

This work was done by Bill R. Aldrich of Microgravity Systems, Inc., for Marshall Space Flight Center. To obtain a copy of the report, "High Field Low Mass Permanent Magnet Furnace and Shielding Development for Applications in Space," write in 52 on the TSP Request Card.

In accordance with Public Law 96-517, the contractor has elected to retain title to this invention. Inquiries concerning rights for its commercial use should be addressed to: Microgravity Systems, Inc.; c/o TBG; Bill R. Aldrich, President; P. O. Box 07007, MS #150; Huntsville, AL 35807. Refer to MFS-26253, volume and number of this NASA Tech Briefs issue, and the page number.

LITERATURE SPOTLIGHT

Free catalogs and literature for NASA Tech Briefs' readers. To order, write in the corresponding number on the Readers Information Request Form (page 81).



WASHERS AND SPACERS

FREE! Boker's 32-page catalog offers 11,000 non-standard sizes with no tooling charges. Outside diameters of 0.080" to 2.631", a wide variety of inside diameters and thicknesses, and 2,000 material variations create millions of

possibilities. Materials include low carbon, cold rolled strip and sheet steel; five types of spring steel; stainless steel; aluminum; brass; copper; nickel silver; and such non-metallic materials as Delrin®, Teflon®, Mylar®, and nylon. Metric sizes also. Tel: 1-800-927-4377; Fax: 612-729-8910.

Bokers, Inc.

For More Information Write In No. 300



RAPIDSYN STEP MOTORS

American Precision Industries' 20 page product guide is a complete source for technical, application and product data for selecting/applying Rapidsyn step motors. Sections include Construction and Technology, Formulas and General Motors Specifications, Size 23, 34, and 42 Step Motors, AC Synchronous Motors and General Driver information. Contact American Precision Industries, Rapidsyn Division, 3229 Roymar Road, Oceanside, CA 92054. Tel: 619-439-7500; Fax: 619-722-5428.

American Precision Industries

For More Information Write In No. 301



PRECISION MOTION CONTROL

API's 132 page motor systems catalog is a complete source for motion control technical, application, and product data. Definitions, market applications, comparison charts, specifications and diagrams simplify the selection/application

process. API products range from full/half step driver modules to high performance microstep systems. Contact American Precision Industries, Controls Division. Tel: 716-631-9800; Fax 716-631-0152.

American Precision Industries

For More Information Write In No. 302

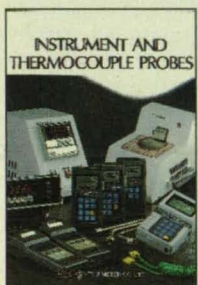

TEMPERATURE MEASUREMENT INSTRUMENTS AND PROBES

Over 3000 units for measuring temperature up to 2400 °F are detailed in this 72-page catalog. Accuracy of 0.2%, response time 0.2 sec. Temperatures of fluids

& gases, stationary & moving surfaces, moving wires, ICs can be measured. Measurement of flat, round & irregular surfaces. Probes for use in the plant, lab or field. Accuracy traceable to NIST. Tel: 800-457-2999.

Anritsu Meter Co. of America

For More Information Write In No. 303



A NEW APPROACH TO SCIENTIFIC DATA ANALYSIS

Analysis Advisor is a free interactive analysis software tutorial that includes demonstrations of graphical and traditional programming methodologies for analysis. You can investigate Digital signal processing, Digital filtering, Windowing, Curve fitting, Signal averaging, Simulation, Interpolation, and Descriptive statistics. Requires Windows 3.1 and 8 MB of memory. Tel: 512-794-1100, 800-433-3488 (US and Canada); Fax: 512-794-8411.

National Instruments

For More Information Write In No. 304

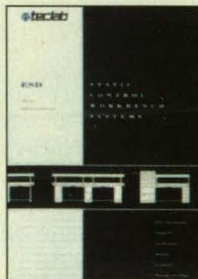

TECLAB ESD WORKSTATION CATALOG

Kalamazoo Technical Furniture's 8-page 4/color brochure details the Teclab line of static protective workbenches, workstation systems, and ESD controlled workstation accessories. Included are color options, product specifications, and various levels of ESD protection available. Teclab also offers a Free Planning and Design Service. Teclab, the "professional's bench." Tel: 1-800-832-5227. Fax: 616-372-6116.

Kalamazoo Technical Furniture

For More Information Write In No. 305

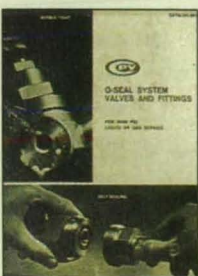

O-RING-SEALED FITTINGS AND VALVES

A full line of flat-faced, O-ring-sealed fittings and valves offering the leak-proof integrity of heat-sealed connections plus slip-in/slip-out accessibility is described. The

O-SEAL SYSTEM fittings and valves, in tube and pipe sizes from 1/8" to 2 1/2", are for liquid and gas service from vacuum to 6,000 psi, from -20 °F to +225 °F. Valves have some of the highest flow characteristics of any hand-operated valves. CPV Mfg., Inc., Tel: 215-386-6508; Fax: 215-397-9043.

For More Information Write In No. 306



PRECISE MOTION CONTROLS

1994 catalog describes full line of servo motion controllers. Includes box-level industrial controllers and multi-axis plug-in boards. PC/XT/AT, STD, VME and RS-232 interfaces available. Linear and circular interpolation, gearing, programmable I/O and memory. Also power amplifiers, servo motors, and support software. Call toll-free: 1-800-377-6329.

Galil Motion Control, Inc.

For More Information Write In No. 307



An eight-page illustrated corporate profile from Yaskawa Electric America provides details about the company's wide range of industrial activities. The color brochure provides information on Yaskawa's motion control products, the Yasnac computer numerical controls, industrial automation products, robotics products and specialty products and services.

Yaskawa Electric America, Inc., 2942 MacArthur Blvd., Northbrook, IL 60062-2028. Tel: 800-633-5756 or 708-291-2340; Fax: 708-291-3457.

Yaskawa Electric America, Inc.

For More Information Write In No. 308



TOOLING COMPONENTS AND CLAMPS

This 500-page catalog contains an assortment of components including toggle clamps, modular fixturing, clamping devices, power workholding, chuck jaws, pins, knobs, drill bushings, leveling feet, power workholding, and much more.

Carr Lane Mfg.

For More Information Write In No. 310

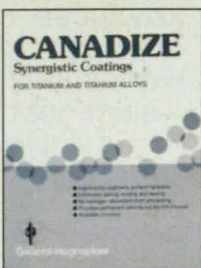

COATINGS PROTECT TITANIUM PARTS

CANADIZE® hydrogen-free super-hard surface-enhancement coatings significantly increase the abrasion resistance and wear life of titanium and produce permanently dry-lubricated surfaces that eliminate galling, binding, and seizing. Protect against corrosion and chemical attack. Unusually wide operating temperature ranging from -200 °F to +1200 °F. Call 908-862-6200. Fax: 908-862-6110. Address is 1331 Route 1, Linden, NJ 07036.

General Magnaplate Corp.
For More Information Write In No. 311



PRECISION COUPLING COMPONENTS

Featuring a wide range of coupling devices in a variety of materials, this 32 page brochure is the latest from Berg. Designed to complement the Inch and Metric catalogs it contains Information Transmitting, Shock Absorbing, Misalignment Couplings. All designed and manufactured to meet the exacting demands of modern industry.

W.M. Berg Inc.

Tel: 516-596-1700; Fax: 516-599-3274.

For More Information Write In No. 312



CATALOG OF CLEANROOM PRODUCTS

TUI's 1,024-page, full-color catalog features pricing and application information on cleanroom products, work stations, controlled atmospheres, storage systems and laboratory equipment, along with microelectronics

manufacturing devices. Informative technical side-bars provide useful references on applications in many industries, including microelectronics/SMT manufacturing, aerospace, and avionics.

Terra Universal Inc.

For More Information Write In No. 313



NEW 1995-96 COLE-PARMER® INSTRUMENTS CATALOG

The new, free 1995-96 Cole-Parmer instruments catalog contains over 1700 full-color pages and features more than 40,000 products covering scientific instruments, equipment, and supplies. The catalog includes a detailed 40-page product index and table of contents, informative introductory pages for many of the catalog sections, "Hot Tips," and an 8-page section of late-breaking products. Contact Cole-Parmer Instrument Company—in the USA or Canada, call toll-free 1-800-323-4340.

For More Information Write In No. 314



GPS-SYNCHRONIZED TIMING PRODUCTS

TrueTime's Precision Timing Devices catalog features GPS-Synchronized Clocks in rackmount, portable, and board-level configurations. Includes illustrations and product specifications for our complete line of Synchronized Clocks, Time Code Products, and Remote Displays to fit a variety of time and frequency applications.

TrueTime, Inc.

For More Information Write In No. 315



MECHANICAL COMPONENTS CATALOG

PIC Design, manufacturer of precision gears, pulleys, and many other mechanical components, has issued their biggest catalog yet. At 240 pages, Catalog 42 now includes a new section of Linear Motion products covering a range of precision

lead screws, precision ground shafting with associated support rails, hangers, and linear bearings. Other new products include Flexible Zero-Backlash Couplings, linear slide guides and economical commercial grade positioning tables with up to 8" of travel. PIC Design, Tel: 203-758-8272; Fax: 203-758-8271.

For More Information Write In No. 316

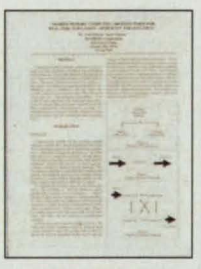

NEW REAL-TIME PRODUCT!

Introducing the SCRAMNet®-LX Network, a real-time communication system based on a replicated, shared-memory concept. Our new ASIC chip reduces board size to a single slot. Call for your FREE paper. SYSTRAN Corporation, Tel: 1-800-252-5601.

SYSTRAN Corporation

For More Information Write In No. 317



MANUAL & MOTORIZED POSITIONING SYSTEMS

Daedal's new 300-page catalog provides specifications for cross roller and ball slides; center and side drive cross roller tables; closed and open frame motorized tables; rail tables; manual and motorized rotary tables; digital micrometer stages; single and multi-axis motion controllers; and half-step, microstepping, and servo motor drives; and optical positioners and hardware.

Daedal Div., Parker Hannifin Corp.

Tel: 800-245-6903; Fax: 412-744-7626.
For More Information Write In No. 318



DSO FEATURES DIFFERENTIAL INPUTS

Model DL3100B is a two channel DSO with true differential inputs, 12-bit vertical resolution, 25 MS/s digitizing and up to 1-Meg of memory. FFT and mathematical computing functions make scope

ideal for electro-mechanical and biomedical applications. Call Yokogawa Corporation of America at 800-258-2552 for a brochure.

Yokogawa Corporation of America

For More Information Write In No. 319

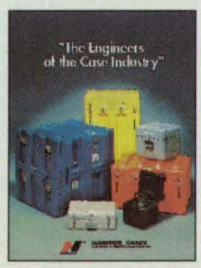

Hardigg Cases offers over 225 standard rotationally molded transit cases, including a full line of 19" EIA rack mount cases, deck cases, and flange-mount cases. Hardigg's expert engineering, manufacturing, and test facilities provide start to finish custom design capability. A complete list of standard cases allows for rapid delivery...

...as few as three working days! Take advantage of over thirty years of experience...design a Hardigg case into your next project!

Hardigg Cases

Tel: 1-800-JHARDIGG; Fax: 413-665-8061

For More Information Write In No. 320

UTILITIES FOR COMPUTER VISION



Two Program Libraries for CADDS-4X and CADDS 5.0. One has 1000s of fasteners and other parts for 3D models, plus AUTOMATIC BILL OF MATERIALS GENERATION. The other has 18 programs, integrated with layer lists. Full DEMO programs are available.

Design Solutions Software Co.

20 Concord Creek Rd., Glen Mills, PA 19342
Tel: 610-358-4054

For More Information Write In No. 321



NEW! OPTICAL REFERENCE CATALOG

Edmund Scientific's free 236-page, full-color annual reference catalog features one of the largest selections of precision off-the-shelf optics and optical instruments, plus a complete line of components and accessories for both large volume OEM users as well as smaller research facilities and optical laboratories. It contains over 8,000 hard-to-find items, including a large selection of magnifiers, magnets, microscopes, telescopes, and accessories. Tel: 609-573-6280; Fax: 609-573-6295

Edmund Scientific Co.

For More Information Write In No. 322



ADVANCED COMPOSITE WORKSHOPS —SINCE 1983

The brochure describes eleven "hands-on" workshops in advanced composite materials technology. These workshops cover fabrication, repair, manufacturing, tooling, blueprint reading, adhesive bonding, engineering design for specialized repairs, and ultrasonic inspection of composites. Emphasis is on prepreg carbon and aramid fiber materials and processes. REFRESHER WORKSHOPS OFFER-ED. Call toll-free: 1-800-638-8441. Fax: 702-827-6599.

Abaris Training Resources, Inc.

For More Information Write In No. 323

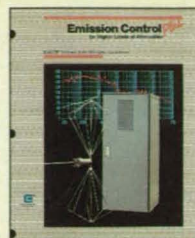

EMCOR FEATURES EMI/RFI ENCLOSURES FOR ALL TYPES OF REQUIREMENTS

Emcor Products offers two lines of modular enclosures to control emissions: The FCC Level Series is used in commercial and industrial requirements and the TEMPEST-style series is used when higher levels of attenuation are required. Both have been tested to MIL-STD-285 at a certified test facility. Tel: 507-289-3371.

Emcor Products

For More Information Write In No. 324



FREE ELECTRONIC HARDWARE CATALOG

Broadest selection of quality hardware for electronic assemblies. 350-page catalog includes a full range of standoffs, captive screws and nuts, chassis fasteners, handles, ferrules, spacers and washers. Special sections include new/unusual products, metric information, and Mil-plating specifications. Full inventory, fast turnaround samples. Accurate Screw Machine Co., 10 Audrey Pl/Box 10095, Fairfield, NJ 07004-6095. Tel: 1-800-237-0013; Fax: 201-244-9177.

Accurate Screw Machine Company

For More Information Write In No. 325

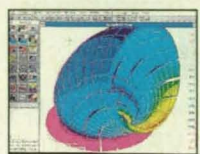

NEW FEA WINDOWS SOFTWARE

EASY: 100% Windows-based modeler with icon toolbar and full point and click operation.

+OPEN: Interfaces to AutoCAD/DXF, IGES

Power Solver

and 18 FEA packages—protects your current investment. +POWERFUL: Fast, new 32 Bit NonLinear solver with Dynamic Memory Allocation and much more. -VALUE: Unlimited Professional Version \$6,995. NT and UNIX versions also available. FOR INFO AND DEMO, CALL 412-826-3470.

Aegis Software Corporation

For More Information Write In No. 326



SINGLE SOURCE DESIGN SOLUTIONS FROM AMP

Brochure 65953 offers a design service available from AMP that provides front-end simulation, analysis design and delivery of turnkey systems by managing the whole process. It eliminates numerous prototype design cycles and is supported by qualified interconnection systems engineers.

AMP Incorporated

For More Information Write In No. 327



This 32-page selection guide includes motor specifications, technical drawings and engineering notes on Anorad's new generation of Anoline® linear servo motors. Motors range from a low-cost brush-type version to brushless sinusoidal motors with velocity above 5 m/sec and forces to 9000 N.

ANORAD

For More Information Write In No. 328



FREE SAMPLES/CATALOG ON PLASTIC CAPS & PLUGS

New 1994 Caplugs Catalog lists specs and ordering information from America's leading manufacturer of protective closures. Includes handy postcards for

ordering free samples of over 800 stock caps, plugs, edge liners, grommets, finishing parts, nettings, load-bearing furniture glides, and ESD protectors. Tel: 716-876-9855; Fax: 716-874-1680.

Caplugs Division, Protective Closures Co., Inc.
For More Information Write In No. 329

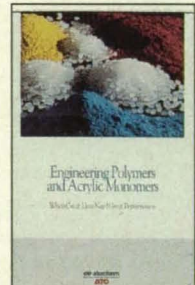

POLYMERS & ACRYLIC MONOMERS

A new, 12-page four-color brochure titled "Engineering Polymers and Acrylic Monomers." Included are polymers and monomers family of products, including Rilsan® 11 and 12 polyimides; Rilsan® powder coatings; Pebax® thermoplastic elastomer resins, Platamid® and Platherm® hot melt adhesives; Platilon® hot melt film, and acrylic monomers. Product description, background, and a sampling of applications are also provided.

Elf Atochem North America, Inc.

For More Information Write In No. 330

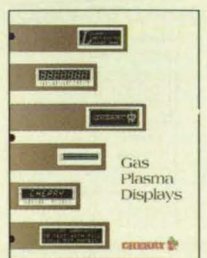

GAS PLASMA DISPLAYS

This new 4C 24-page catalog describes Cherry's Gas Plasma Displays. It highlights Cherry's Plasmodot™ Full Field Dot Matrix Displays, Smart Interface Controllers, DC-DC Converters, Segmented (Numeric and Alphanumeric), and Bar Graph Displays.

Typical applications include: equipment instrumentation (medical, home, office), amusement (arcade/game systems, lottery terminals), process control instrumentation, and other markets (vending machines, ATM, point-of-sale terminals). Tel: 708-662-9200; Fax: 708-662-3566.

Cherry Electrical Products

Write In No. 331 For Immediate Need or No. 369 For Future Need

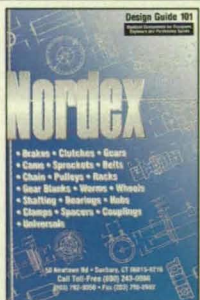

THE ULTIMATE DESIGN GUIDE

FREE!! The new Design Guide 101 from Nordex offers 500 pages of standard, specialized & unique instrument grade mechanical components.

Gears, Racks, Sprockets, Gear Boxes & Speed Reducers; Precision Linear and Radial Bearings; Precision Ground Shafting & Supports; Assorted Belts & Pulleys; Couplings, Clutches; Precision Hardware and much more from a vast stock!!

Modified Standards and Build to Print components and assemblies are our specialty. Nordex Inc., Tel: 800-243-0986, in CT: 203-792-9050.

For More Information Write In No. 332



FREE DESIGN AID

Save layout time and eliminate detailing with this 16 page Template catalog. This catalog shows FULL SIZE drawings of many tooling components used in designing jigs and fixtures. It includes Spring & Ball Plungers, Nuts, Bolts, Washers, Knobs and many

other items, all with sizes and part numbers. Also included will be a copy of the current catalog listing these and additional items, along with prices. Northwestern Tools, Inc., Tel: 513-298-9994; Fax: 513-298-3715.

Northwestern Tools, Inc.

For More Information Write In No. 333



TOOLING COMPONENTS & EQUIPMENT

New 400 page reference catalog offers a full range of tooling components and equipment. Items include handwheels, handles, knobs, spring & ball plungers, leveling pads, clamps, set up accessories, locating devices, cutting tools, rivets, thread inserts, hard to find tools and metric items. Contains complete specifications and pricing. All items are stocked for same day shipment. Reid Tool Supply Company, 2265 Black Creek Rd. Muskegon, MI 49444. Tel: 800-253-0421; Fax: 800-438-1145.

Reid Tool Supply Company
For More Information Write In No. 334

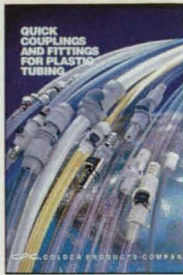

QUICK COUPLINGS FOR PLASTIC TUBING

Colder Products Company's New 48-page Catalog of quick disconnect couplings and fittings for plastic tubing. Six new designs, over 700 sizes and configurations in thermo-plastic or chrome-plated brass for 1/16" to 3/4" plastic tubing. Couplings for pipe thread, panel mount or in line. Straight thru flow, single- or double-sided shutoffs, gamma resistant and multiple flow path couplings. New HFC High Flow™ plastic couplings for 3/8", 1/2" and 3/4" tubing. Tel: 612-645-0091.

For More Information Write In No. 335



SAVE ON PRESSURE TRANSDUCERS

\$50 off list price on 1800 Series pressure transducers. Total error band of ±1.5% FSP, including zero and span offset internally corrected errors from -55 °C to 125 °C. MIL-STD/DO-160 qualified. Solid state silicon sensors. Pressure ranges to 5000 psi. Respond by August 31, 1994. Tel: 612-892-4024; Fax: 612-892-4430.

Rosemount Aerospace Inc.
For More Information Write In No. 336

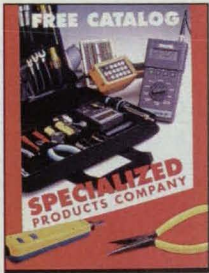

TOOLS, TOOL KITS, CASES & TEST EQUIPMENT

Installation/repair tools, tool kits, test equipment, telecom equipment, LAN testers & instrument/shipping cases are detailed in this 300+ page full-color catalog. Includes products for field service & depot repair. Indexed catalog features over 100 standard tool kits & complete information on "customizing" to meet specific customer requirements. Complete specs & prices are provided for all products. Tel: 800-866-5353; Fax: 800-234-8286.

Specialized Products Co.
For More Information Write In No. 337

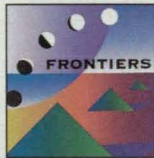

TWO GREAT DATA ANALYSIS TOOLS

Spyglass presents two great data analysis tools for the price of one: the Spyglass Frontiers CD and The Data Handbook—both for just \$39.95. Frontiers shows you how other researchers are using visualization to analyze and present their data. Frontiers also contains the original data which can be read by any of the Spyglass software tools; and many exciting scientific After-Dark™ screen savers. The Data Handbook is an invaluable, 229-page desktop reference that presents what every technical person should know about computers, how they handle numbers, and what this means for organizing and visualizing data. To order, call 1-800-647-2201.

Spyglass
For More Information Write In No. 338



The 1994 REMCOR® Catalog describes the new line of water Chillers and Recirculators. The easy to read tables and graphs make applications, and Chiller identification simple and convenient. Send for the complete Chiller Catalog today. Remcor Products Company, 500 Regency Drive, Glendale Heights, IL 60139. Tel: 708-980-6900; Fax: 708-980-8511.

Remcor Products Company
For More Information Write In No. 339

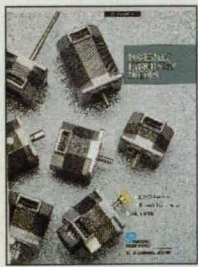

STANDARD AND CUSTOM POWERMAX™ STEP MOTORS

New 18-page specifier's guide features Powermax™, the highest torque available from NEMA 23 hybrid step motors. Illustrates standard motors and dozens of popular modifications made economical by flexible manufacturing. Pacific Scientific, Rockford, IL. Tel: 815-226-3100. Fax: 815-226-3080.

Pacific Scientific
For More Information Write In No. 340



NEW ALGOR PRODUCT GUIDES AVAILABLE

Find out why Algor is the choice of more than 10,000 engineers in 50 states and over 60 countries. Product Guide Part 1 has details on Algor's latest design and modeling products, including exclusive Merlin mesh enhancement technology and Hexagen fully-automatic, 8-node solid "brick" mesh generator. Part 2 offers a complete technical overview of Algor's analysis capabilities.

Algor
For More Information Write In No. 341



MSC/NASTRAN is the world's leading comprehensive FEA software. A powerful, highly flexible analysis and optimization program on an open architecture, MSC/NASTRAN analyzes the stress, vibration, and heat transfer characteristics of structures and mechanical components. The MacNeal-Schwendler Corporation, 815 Colorado Blvd., Los Angeles, CA 90041-1777; Tel: 800-642-7437, ext. 500.

MacNeal-Schwendler Corporation
For More Information Write In No. 342



PRECISION SYRINGE DRIVE MODULE (PSD/2)

The PSD/2, designed specifically for OEMs, is a highly integrated, self-contained, syringe drive module. Combine it with Hamilton syringes, valves, and valve positioners to create an optimized turnkey system, providing exceptional accuracy and precision. Tel: 800-648-5950.

Hamilton Company
For More Information Write In No. 343



MODULAR VALVE POSITIONER (MVP)

Hamilton's MVP is a self-contained, bi-directional valve positioner used for fluid manipulation/distribution. It allows you to direct fluids manually, with TTL output, or via RS-232 communication. It's easily configured for use with any of 16 Hamilton valves. Tel: 800-648-5950.

Hamilton Company
For More Information Write In No. 344



SURFACE ROUGHNESS/THICKNESS TESTER

The DEKTAK³ provides extremely accurate measurements of surface roughness and film thickness for microelectronic and other thin film applications. It is used to control and monitor surface roughness, thin film deposition and etching in semiconductor, magnetic media, and flat panel manufacturing.

Veeco/Sloan Technology
For More Information Write In No. 345

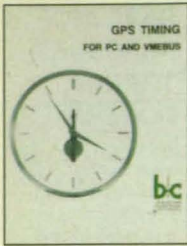

GPS TIMING FOR PC VMEBUS

This information folder from Bancomm describes new PCbus and VMEbus board-level Global Positioning System (GPS) Satellite Receivers. These products provide worldwide precision time (100 nanosecond) and frequency (1 part in 10E7) references inside the host computer.

Bancomm

For More Information Write In No. 346

Z ELEVATOR POSITIONER

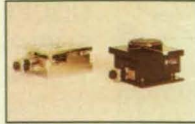

- Low Profile: 2.5" collapsed height
 - Horizontal Lifting Surface: objects mount to the top of our Z Elevator so they are fully supported
 - High Resolution: to 4 micrometers
 - Embedded Theta Option: for fine angular alignment
- NEAT's new Z Elevator stage is ideal for many applications including semiconductor and biological inspection and probing, digital laser imaging, flip chip bonding, autofocus, and laser testing. For more information or to discuss your application requirement, please contact our Sales Engineering staff at 1-800-227-1066.

New England Affiliated Technologies
For More Information Write In No. 347



B92 CATALOG RELEASE

The latest catalog from W.M. Berg, Inc., coincides with Berg's silver anniversary. Founded in 1967, Berg has grown to become a recognized industrial leader of miniature precision mechanical components. A significant number of new items are added as well as expanding previous product lines. Featuring 50,000 standard components, 80% of which we are able to ship from stock within 24 hours. Available in metric version too: M92. Tel: 516-596-1700; Fax: 516-599-3274.

W.M. Berg

For More Information Write In No. 348

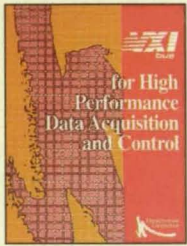

VXI HIGH PERFORMANCE DATA ACQUISITION

FREE BROCHURE from the world's leading producer of VXI high performance data acquisition and control solutions. Topics: Is VXI right for you? Meet the "Silver Bullet" VXI products*, How plug&play keeps your options open, DAQ software—what do you really need? Plus, new ways to handle large channel counts and high data throughput using fiber optics. Tel: 800-DATA-NOW; Fax: 815-838-4424. *Named "Best Hardware Product" by "VXI Newsletter," 1993.

KineticSystems Corporation

For More Information Write In No. 349



FREE FOAM SAMPLE MATERIALS

Included are separate specification sheets, as well as a standard-grade property comparison chart listing

sizes, densities, strengths, and other properties for the usage and selection of foams. Sample pieces feature: Volara—irradiation crosslinked polyolefin; Volara S-types—second-generation cross-linked foams, Volextra—a composite that has been enhanced, and Minacel. 100 Shepard St., Lawrence, MA 01843. Tel: 508-685-2557. Fax: 508-685-9861.

Voltek, Div. of Sekisui America Co.

For More Information Write In No. 350

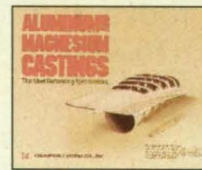

LIGHTWEIGHT MAGNESIUM ALUMINUM CASTINGS

Brochures describe unique prototype, pre-production and production capabilities of this modern foundry.

Quality system complies with ISO 9000, automotive, aerospace and government specifications. Uses sand, Investocure, gravity, die and squeeze processes. Offers both low and high volume SPC controlled production. Complete in-house laboratory and testing facilities. Call 216-581-9200. Fax: 216-475-6611.

Thompson Casting Co., Inc.

For More Information Write In No. 351



PICO SCOPEMAN, A UNIQUE VIDEO MICROSCOPE

Magnify 25x to 600x with this compact, lightweight video microscope. Weighing less than two pounds, PICO Scopeman can be hand-held or stand mounted for flexible usage. PICO displays a sharp, clean image on a video monitor for easy inspection. For more information, contact Moritex USA, Inc. at 1-800-548-7039.

Moritex USA, Inc.

For More Information Write In No. 352

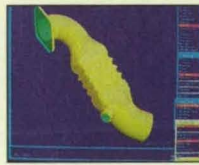

NON-STOP FROM PRO/E TO ANALYSIS & OPTIMIZATION

COSMOS/M ENGINEER makes it easy and affordable to include analysis and optimization on every design itinerary. Its seamless interface to Pro/E fully integrates the design, preprocessing and postprocessing features of Pro/E with the analysis and optimization power of COSMOS/M: statics, buckling, frequency, heat transfer, optimization, nonlinear, advanced dynamics, a super fast solver and two meshing capabilities. Starting at \$6500! Call 310-452-2158 (west) or 412-635-5100 (east).

COSMOS/M

For More Information Write In No. 353

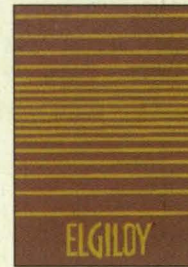

PRECISION STRIP/WIRE

Elgilloy® is a combination strip and wire mill. We process a variety of alloys including Inconel®, Hastelloy®, Monel®, MP35N®, Titanium and Stainless. Our sales and engineering staff are qualified to handle your custom material requirements, and our on site testing lab assures you of prompt deliveries. Tel: 708-695-1900; Fax: 708-695-0169.

Elgilloy® Limited Partnership

For More Information Write In No. 354



NEW 8 1/2 DIGIT DMM

Keithley Instruments introduces the Model 2002 Digital Multimeter, with extremely high resolution and high accuracy specifications. It offers 2 ppm DC stability, 6 ppm basic DC voltage accuracy, 8 ppm basic ohms accuracy, and 300 ppm basic AC voltage accuracy. The 2002 also offers frequency measurements to 15 MHz with an adjustable trigger. Keithley Instruments, Inc., 28775 Aurora Rd., Solon, OH 44139. Tel: 1-800-552-1115.

Keithley Instruments, Inc.

For More Information Write In No. 355

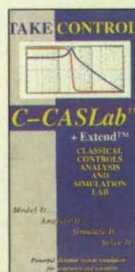

CONTROLS SYSTEMS MODELING & DYNAMIC SIMULATION LAB

388 preprogrammed blocks ready to drag-&-drop, connect to form a model, and simulate. Build 95% of models in both Ogata (90) & Nise's (92) books. Empirical & ODE solutions. Included: the powerful custom block development application, Extend. Very friendly dialogs, enhanced animation, message handlers, include files, sensitivity analysis, customized reporting, plotters, advanced math, pop-ups & much more. Build your own.

AC Engineering Systems, Inc.

Tel: 219-489-2226

For More Information Write In No. 356

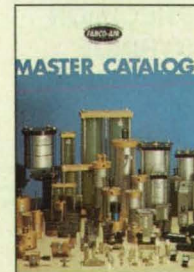

PNEUMATIC COMPONENTS

210-page catalog #CV5 details a broad product line including Pancake®, Multi-Power®, other cylinders, special purpose and directional control valves, port-mounted flow controls, manifolds, vacuum generators, barbed fittings, and air presses. Fabco-Air Inc., 3716 NE 49 Rd., Gainesville, FL 32609. Tel: 904-373-3578; Fax: 904-375-8024.

Fabco-Air Inc.

For More Information Write In No. 357



TROMPETER'S NEW 24-PAGE SP1 CATALOG

A new way to order Trompeter products! High quality, premium value RF interconnect components... Coax/Twinax/Triax Patching, Connectors and Cables.

- Complete part numbers to use the standard parts price list
- 100 other products on New SP1 Standard Parts Price List
- Large inventory, quick delivery
- New Customer Order Form available
- Call toll-free (800) 217-2020
- Sales department support
- Use SP1 Standard Parts Price List
- Fax to your order (919) 705-1040

with our new SPL1 Standard Parts Price List. • Large inventory for quick delivery. • New custom order forms and 800 toll-free number. • Low \$25 minimum order.

Trompeter Electronics, Inc.
Tel: 1-800-217-2020; Fax 818-706-1040.
For More Information Write In No. 358



RECIRCULATING CHILLERS

64-page catalog features a complete line of recirculating chillers for cooling water-cooled equipment. These chillers offer steady cooling with heat load removal up to 75 kW, spanning temperature ranges of +5 °C to +35 °C. Chillers feature 1) ozone-friendly refrigeration systems, 2) LED display, 3) operating status gauges, 4) and easy access to internal components. Also available is CFC-free Constant Temperature Equipment. Call toll-free at 1-800-258-0830.

NESLAB Instruments, Inc.
For More Information Write In No. 359

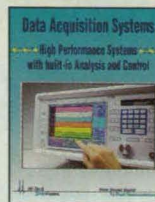

COLOR WORKSTATION FOR DATA ACQUISITION AND ANALYSIS

The HT600 combines internal math algorithms with high speed, high resolution digitizing of analog signals. A built-in VGA color graphics interface with touch panel, mouse or keyboard entry increases ease of use. It boasts sampling rates from 1 sample/sec. to 200 Megasamples/sec. with memory sizes 2k to 32 Meg and digitizers from 8 bits to 16 bits. From \$15,500, depending on digitizers & memory length. Delivery: 30-45 days ARO. Contact: Garry Williams, 1-800-248-1633.

Hi-Techniques, Inc.
For More Information Write In No. 360

NEW DISPLACEMENT MEASURING INTERFEROMETER SYSTEM

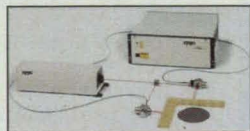

Zygo's ZMI-1000 provides high-resolution, noncontact, displacement measurement for precision motion systems. Resolution is 0.6 nm at velocities up to 1.1 m/s. Also measures angular rotations up to 60 degrees with 0.1 mrad resolution. Brochure available.

ZYGO CORPORATION

Laurel Brook Road, Middlefield, CT 06455-0448
Tel: 203-347-8506

For More Information Write In No. 309

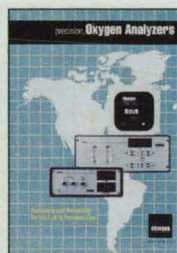

OXYGEN ANALYZERS

A full-color brochure introduces a complete line of oxygen analyzers for the laboratory or process line. They are ideally suited for monitoring the oxygen levels in all types of gas streams. Trace oxygen levels from ppb to 100% are accurately determined by these ruggedly constructed instruments. No periodic maintenance or special operator skills are required. Intrinsicly-safe and battery-operated models are also available.

these ruggedly constructed instruments. No periodic maintenance or special operator skills are required. Intrinsicly-safe and battery-operated models are also available.

Illinois Instruments Inc.

For More Information Write In No. 361



CURRENT PREAMPLIFIER

The SR570 is a low noise (5 fA/√Hz) transimpedance preamplifier capable of current gains as large as 10³ V/A. Two configurable filters offer high-pass, lowpass, or bandpass signal conditioning over the instrument's 1 MHz bandwidth. The amplifier can be operated from the AC line or from its internal rechargeable batteries, which provide up to 15 hours of operation.

the instrument's 1 MHz bandwidth. The amplifier can be operated from the AC line or from its internal rechargeable batteries, which provide up to 15 hours of operation.

Stanford Research Systems

For More Information Write In No. 362



ULTRA-HARD MATERIALS FABRICATION

Insaco's brochure describes the custom manufacture of components in sapphire, ruby, quartz, ceramics of all types including glass-ceramics, alumina, zirconia, carbides, and nitrides. The company routinely

fabricates these materials for applications in optics, chemistry, vacuum, bearings, electronics, nuclear, space and medicine. Tolerances are measured in millionths of an inch with surface finishes in angstroms and flatness to fractions of a wavelength. Tel: 800-959-0264; Fax: 800-959-0267.

Insaco, Inc.

For More Information Write In No. 363



ELECTRO-MAGNETIC DESIGN SOFTWARE

The legendary Vector Fields suite of software, including the TOSCA, ELEKTRA and OPERA packages, combines classical finite element techniques with user friendly interactive graphics for high accuracy 2D and 3D simulation and design of all types of electromagnetic equipment.

Vector Fields Inc.

1700 North Farnsworth Avenue
Aurora, IL 60505

Tel: 708-851-1734 Fax: 708-851-2106

For More Information Write In No. 364

UV-LASER FOR MICROMACHINING

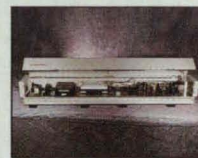

The Model 266DP-0 Q-switched UV Nd:YAG Laser provides diffraction-limited output power of 600 milliwatts at 266 nm and 8 watts at 532 nm. Applications are micromachining of silicon, glass, diamond, polyimide and ceramic materials. Tel: 516-273-6900; Fax: 516-273-6958.

Excel Quantronix

For More Information Write In No. 365

Best of All Worlds...

In Ruggedized Video Cameras

Ruggedized Qualified

- 7 G's RMS Vibration
- 470 TV Lines Resolution
- Color (NTSC or Y/C)
- Miniature, Only 1" x 1" x 5"
- Weighs Less than 6 ozs.
- Low Light 4.5 Lux
- Remote Head, Right Angle or Straight Versions



SEKAI INTERNATIONAL

14535-H Valley View Avenue • Santa Fe Springs, CA 90670-5234

Tel: 310 • 921-7775; Fax: 310 • 921-7875

For More Information Write In No. 366

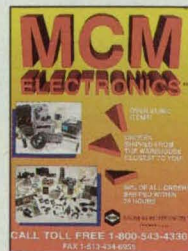

MCM ELECTRONICS OFFERS NEW 288 PAGE CATALOG FREE!

MCM Electronics, the industry leader in the distribution of consumer electronic repair parts and accessories. Catalog #33 contains more than 21,000 items, including semiconductors, speakers, test equipment, computer products, audio, TV, VCR and appliance repair parts. This catalog is a "must have" for all service technicians and electronic enthusiasts. Call TOLL FREE, 1-800-543-4330.

including semiconductors, speakers, test equipment, computer products, audio, TV, VCR and appliance repair parts. This catalog is a "must have" for all service technicians and electronic enthusiasts. Call TOLL FREE, 1-800-543-4330.

MCM Electronics

For More Information Write In No. 367



FELTON CAPABILITIES & PRODUCT DESIGN

Felton Brush Inc. is offering a new, four-color brochure that outlines its extensive application, product development, machine design and quality production strengths. The company features innovative technology in metal strip brush design and production for OEM applications. Brush design parameters and construction options are detailed. Featured are: metal strip brushes including nylon brush seals, machine guards and Flex-Guard™ flexible containment seals.

novative technology in metal strip brush design and production for OEM applications. Brush design parameters and construction options are detailed. Featured are: metal strip brushes including nylon brush seals, machine guards and Flex-Guard™ flexible containment seals.

Felton Brush Inc.

For More Information Write In No. 368

SONEX. 400% BETTER.

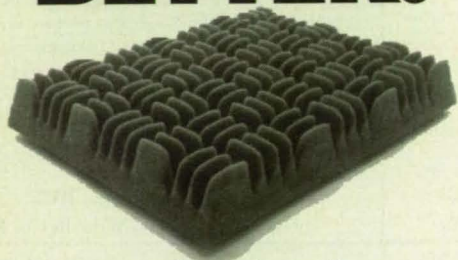

So unique, so advanced, so effective, SONEX is 400% better than other noise control products. Find out why. Send for your free brochure.

FREE BROCHURE!

illbruck

Minneapolis, Minnesota

**1-800-662-0032
(612)520-3620**

For More Information Write In No. 435

Thermofoil™ Heater/Sensors

FORM

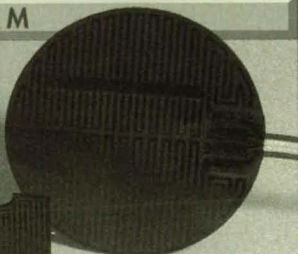

FIT

Medical diagnostic instrumentation • Aerospace devices

FUNCTION

Flexible heaters have their own built-in temperature sensors for fast response and tight control.

- Kapton, silicone rubber, polyester insulation
- Resistance thermometers with platinum and other elements, thermocouples, and thermistors
- Irregular shapes and profiled heat patterns adapt to any heat sink

7300 Commerce Ln.
Minneapolis, MN
55432-3177 USA

MINCO
PRODUCTS, INC.

Phn: 612/571-3121
Telex: 687-9025
FAX: 612/571-0927

For More Information Write In No. 436

New on the Market

Indalloy® #227 **lead-free solder** has been formulated by Indium Corporation of America, Utica, NY, to serve as a replacement for Sn63Pb37, Sn60Pb40, and Sn62Pb36Ag2 without any changes in equipment, process chemicals, or reflow temperatures. The compound compares favorably with common lead-based solders in electrical and thermal conductivity, thermal coefficient of expansion, tensile strength, metallization compatibility, and wettability.

For More Information Write In No. 711



The RB-1000PC **virtual reality board** from Synthetic Images Inc., Orlando, FL, is the first to employ the company's Reality Blaster™ technology uniting RISC, DSP, and custom processor hardware with advanced math algorithms. The RB-1000PC is a standard IBM PC-compatible full-length ISA card that can hold an entire virtual world in its onboard memory and then render it at high resolution (640 x 480 VGA) at 30 frames per second.

For More Information Write In No. 700

Version 2.0 of TAPP, a **database listing the thermochemical and physical properties of more than 17,000 materials**, has been released by E S Microware, Hamilton, OH. Properties listed—for both organic and inorganic solid, liquid, and gas compounds—include crystal structure, density, thermal expansion, elasticity, thermal conductivity, diffusivity, electrical resistivity, viscosity, surface energy, vapor pressure, and specific heat.

For More Information Write In No. 713

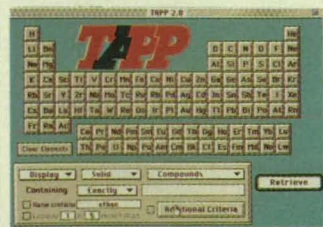

The industry's first locking, rotatable **flange** was designed by Varian Associates Inc., Palo Alto, CA, to simplify and speed the assembly of ultra-high vacuum systems. The patented ConLok™ flange holds the rotatable receiver in place on the stationary insert of the flange, making it easier to install the bolts.

For More Information Write In No. 712



Control Techniques Drives Inc., Grand Island, NY, has announced the Quantum III, a compact micro-computer-based **digital DC drive** that gains flexibility from a universal AC input line voltage (208-480 VAC) and a 5-1000 HP range in both regenerative and nonregenerative models. All control loops are handled in real-time software, and the drive automatically tunes the current loop parameters specific to its DC motor for fast, reliable start-up.

For More Information Write in No. 706



The 5500A multiproduct **calibrator** introduced by Fluke Corp., Everett, WA, offers electrical work-load coverage to calibrate a broad range of DC/low-frequency instrumentation, including digital and analog multimeters, oscilloscopes to 200 MHz, ScopeMeter® test tools, thermometers, and power harmonics analyzers. The unit sources DC and AC voltage to 1000 V, DC and AC current to 11 A, frequencies from 2 Hz to 2 MHz with multiple waveforms, variable resistance from a short to 220 MΩ, and variable capacitance from 330 pF to >1 μF.

For More Information Write In No. 705

To reduce battery drain in automotive and portable electronic equipment, Cherry Semiconductor Corp., East Greenwich, RI, has developed a **dual-voltage linear regulator** that draws just 70 μA of quiescent current when circuitry is in the idle mode. The CS-8147 provides a primary output of 10 V, ±2.5% with a 500 mA capability to drive lamps, displays, and other high-voltage components, and a secondary output of 5 V, ±5% with a 70-mA capability to power microprocessors, memory, and logic circuitry.

For More Information Write In No. 704

New on the Market

Intergraph Corp., Huntsville, AL, has announced a new version of its Engineering Modeling System (EMS) of **integrated computer-aided design, manufacturing, and engineering software tools**. EMS 3 offers enhanced capabilities in variational solid modeling, mechanical design, finite element and kinematic analysis, plastics engineering, fabrication, numerical control programming, and multiple-system interoperability. The package supports hardware from Intergraph, Silicon Graphics, and Sun Microsystems.

For More Information Write In No. 708



ChemOffice software introduced by OMEGA Engineering, Stamford, CT, integrates **chemical structure drawing, molecular modeling, and information management**. A 3D feature enables users to analyze and visualize compounds stored in chemical databases, build molecular models using any element, convert 2D structures to 3D models, and work with 5000+ atom models.

For More Information Write In No. 701



Warner Electric, Bristol, CT, has introduced the Model SS2000D12 SLO-SYN[®] high-performance, high-power **step motor drive**. Offering power up to 3 HP, the unit operates directly from a 230 VAC line—as a result, the 350 VDC bus voltage produces maximum torque and speed for applications such as material forming, spring winding, machining, and parts positioning.

For More Information Write In No. 702

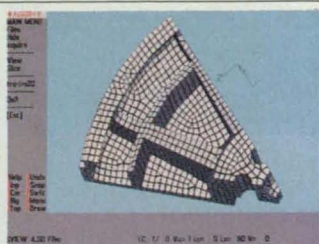

Algor Inc., Pittsburgh, PA, has released Houdini, the first software to offer fully automatic **generation of eight-node "brick" finite elements** directly from a CAD solid modeling source. The program works with a broad array of CAD/CAM design systems, including Pro/ENGINEER, AutoCAD, Aries, Unigraphics, Cadkey, Catia, SDRC, and Intergraph, and can export to any CAE software.

For More Information Write In No. 710

Cog-Buster **hysteresis brakes and clutches** from Placid Industries Inc., Lake Placid, NY, make slip torque smooth under virtually all operating conditions. Hysteresis brakes—which offer highly repeatable torque, long-term stability, and a wide speed range—are subject to cogging. Brakes with the patented Cog-Buster feature can be decoupled automatically with a single turn of the shaft, regardless of the torque.

For More Information Write In No. 709



A new **digital memory module** from NAC Visual Systems, Woodland Hills, CA, quickly transforms any of the company's HSV-500 cameras—color or monochrome—into **digital high-speed video recording systems**. This option enables continuous loop recording, immediate image recall, higher resolution, and easy integration with other digital computer-based motion analysis tools.

For More Information Write In No. 707

The RGB FASTFilter[™], an electrically switchable **color filter** for use in field sequential color display systems, has been unveiled by Displaytech Inc., Boulder, CO. The device can be combined with high-resolution, black-and-white CRT tubes to create small full-color display systems for such applications as helmet- and head-mounted displays, miniature color displays, and portable display systems.

For More Information Write In No. 703

Smallest position sensor ever



For the tightest installations, Kaman's 0.080-inch diameter sensor lets you resolve microscopic displacements down to 4 microinches at 50 kHz, without contact. Ideal for both magnetic and non-magnetic materials, this sensor is only one of Kaman's 24 standard sensors that let you see small changes in position. Call us for details.

*Kaman Instrumentation, 1500 Garden of the Gods Road, Colorado Springs, Colorado 80907
Phone 719-599-1825, Fax 719-599-1823
800-552-6267*

KAMAN

For More Information Write In No. 420

Make sure the air filter does justice to your O.E.M. design

Specify Universal, and get air filters custom designed to:

- Meet your specs precisely
- Keep your product clean
- Be easily maintained
- Withstand serious abuse

...air filters custom manufactured with a wide choice of media, to close tolerances, under strict quality control, by people who value their reputation.

Phone or Fax now while you're thinking about it, for a free sample filter and technical data. Call 1-800-541-3478 or 618-271-7300, or Fax 618-271-8808.

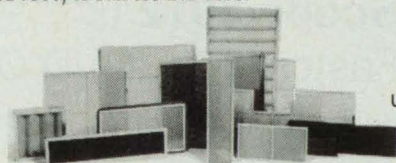

U.L. Listed

On spec . . . on time . . . everytime

Universal air filter company



3400 Missouri Avenue P.O. Box 853
East St. Louis, Illinois 62203

For More Information Write In No. 421

THERMALLY CONDUCTIVE EPOXY



MASTER BOND EP21TCHT-1 EPOXY SYSTEM

- Outstanding electrical insulation
- Passes NASA outgassing specs
- Fast room temperature cure
- Heat resistance up to 400°F
- Superior environmental protection
- High dimensional stability
- Convenient packaging

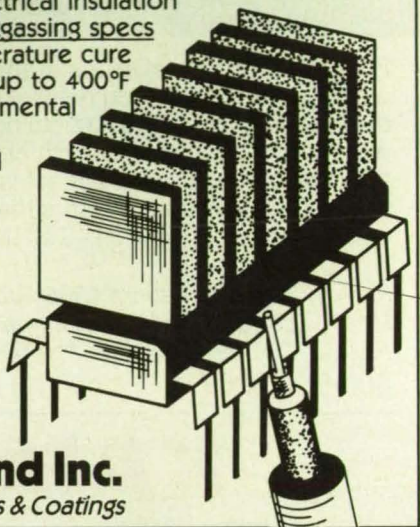

For information, call or write:
Master Bond Inc.,
154 Hobart St.
Hackensack, NJ 07601
201-343-8983

Master Bond Inc.
Adhesives, Sealants & Coatings

For More Information Write In No. 422

60 MSPS 12 BIT A/D CARD

- ◆ 61 dB SNR
- ◆ 30 MSPS on 2 ch.
- ◆ Very Deep Buffers
- ◆ Up to 32 ch. Systems

Drivers in
C, Pascal,
BASIC,
Windows DLL,
LabVIEW,
LabWindows,
DasyLab,
HyperSignal ...

CompuScope 6012 World's Fastest 12 Bit A/D Card

CSLITE	8 bit / 40 MSPS / 16K	\$595
CS220	8 bit / 40 MSPS / 256K	\$1,995
CS250	8 bit / 100 MSPS / 32K	\$3,500
CS1012	12 bit / 20 MSPS / 512K	\$4,995
CS6012	12 bit / 60 MSPS / 512K	\$6,995

CALL 1-800-567-GAGE

Gage Applied Sciences Inc.

5465 Vanden Abeele, Montreal, Quebec, Canada H4S 1S1
From outside North America, call + 1-514-337-6893
Fax: (514) 337-8411, BBS: (514) 337-4317

GAGE

For More Information Write In No. 423

New Literature

Four application notes published by National Instruments, Austin, TX, highlight **programming tools and techniques for developing instrumentation systems** under Microsoft Windows. Available in LabWindows®/CVI application development software, these tools simplify writing ANSI C programs for controlling data acquisition and instrumentation hardware from a PC. Topics include GUI techniques, debugging tools, and object modules.

For More Information Write In No. 718



A 288-page catalog and reference guide to **PC-based data acquisition hardware and software** is available from Keithley MetraByte, Taunton, MA. New products, many of which are optimized for use with Microsoft Windows, include the DAS-1800 and DAS-800 families of plug-in data acquisition boards, the DAS-TC thermocouple input board, and Visual-DAS™ custom control software.

For More Information Write In No. 716

The Dash 10, a new 10- to 30-channel **field and laboratory recorder**, is showcased in a brochure from Astro-Med Inc., West Warwick, RI. The unit features a bright vacuum-fluorescent monitor, an internal rechargeable battery, 300-dpi laser-quality printing, built-in signal conditioning, a 1.44-MB floppy disk drive, and 1.2 MB of RAM per channel. It records signals ranging from 50 mV to 500 V peak (isolated) at frequencies from DC to 25 kHz.

For More Information Write In No. 717

A **scan converter buyer's guide** released by Communications Specialties Inc., Hauppauge, NY, is designed to assist both novices and those familiar with video scan conversion technology. Sections include "Six Common Misconceptions About Converting Computer to Video," which provides basic knowledge, and "Eleven Questions You Should Ask Before Buying a Computer Video Scan Converter."

For More Information Write In No. 720



StatiCon Inc., Englewood, CA, has published a brochure highlighting its transparent plastic sheets and films for rapid **static control** in sensitive electronic, medical, and micromanufacturing environments. Also described is the use of StatiCon's AC-300 cast acrylic sheet as a replacement for glass to eliminate sodium ion emissions in clean rooms and mini-environments.

For More Information Write In No. 715

Shell Chemical Company, Houston, TX, has introduced the **Resins & Curing Agents Physical Properties Guide** describing more than 300 high-performance **resins** for coating, structural, electronic, and composite applications. Products include EPON® resins, EPI-REZ® waterborne resins, EPI-CURE® curing agents, HELOXY® modifiers, and COMPIMIDE® bismaleimide resins.

For More Information Write In No. 719

The 1994 **scientific and laboratory products** catalog from Newport Corp., Anaheim, CA, features 20 new application notes. More than 300 new products are described, including inch-dimensional versions of Micro-Control positioning and motion control products, low-GVD optics for ultrafast laser systems, the PX-D7 ultrafast photodetector, and a dual-channel optical multimeter.

For More Information Write In No. 714

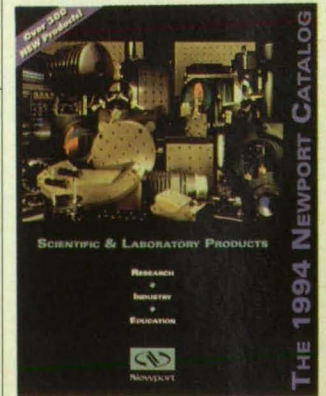

POSITIONS WANTED

Ex-NBS/NASA physicist/engineer. Productive researcher in atomic physics, time/frequency, spectroscopy, remote sensing, STM, energy conservation, highway safety. Enthusiasms: advanced control logic, efficient vehicles. Innovator in measurement science, especially optical and electronic instrument design and calibration. Designer of data acquisition and analysis HW/SW. VA-DC-MD area. **Box number 88C**

BS communications engineer, designer hardware & software, analog and digital circuit, data acquisition. Printed circuit manufacturing, design, layout. A/D and D/A converter application. Seeking computer-aided electronic design position with opportunity for advancement. Very familiar with programming and applications software. Tel: Alexandria, Egypt 011-20-3-854746. **Box number 89C**

BSE in biomedical engineering, MS and Ph.D in materials science and MBA. Excellent technical, business and interpersonal skills. Experience in emerging technology (engineering and physical sciences) licensing, sales, marketing, strategic analysis, R&D. Involved in review/preparation of business plans for technology-based businesses. Interested in new business development opportunity. **Box number 90C**

Ph.D (1992) in optics. Graduate experience in bulk and surface nonlinear wave mixing. Postdoctoral experience in stabilized diode lasers and magneto-optic atom traps. Background in laser systems, optical instrumentation, computer-assisted data acquisition and analysis, and numerical modeling. 10 publications. Seeks laboratory R&D position. AT&T Easy Reach: 10-ATT-0-700-613-3636. **Box number 91C**

Program/engineering manager with BSME, PE, DOD clearance, SBI, 19+ years of government/commercial experience in analysis, design/facilities/test engineering, project/program/construction/engineering/laboratory management, business development, proposals, government procurement, scheduling, budget control, MRP II, TQM & concurrent engineering seeks new challenges. **Box number 92C**

Ph.D in applied physics (1992), BSEE (1987). Seeks experimental nonlinear optics, electro-optics, laser diagnostics position. Industrial/postdoctoral experience with lasers, multichannel detectors, optical equipment, analog/digital electronics, control/data acquisition software. 23 publications/conference presentations. Fluent in French and Turkish. **Box number 93C**

Design engineer—robotics and automation. BSIE with 33 years experience in aerospace, industrial and military systems. Strong in autonomous and lunar/mates, as well as UAV-UGV systems. Have TS and Q clearance. Past chair of COS-SAR, assoc. fellow-AIAA. **Box number 94C**

Ph.D experimental physicist, Auger, x-ray photoelectron spectroscopy and ultra-high vacuum experience. High temperature strain gage data acquisition and analysis. Designed instrumentation to measure electrical resistance of ceramic thin films at high temperature. Excellent computer skills, PC and Mac, hardware and software, FORTRAN, BASIC, and assembly languages. CAD experience. **Box number 95C**

Ph.D mechanical engineer with record of accomplishments in medical products. Project management experience in R&D, experimentation, design, manufacturing. Strong technical, analytical abilities; excellent communicator. Self-starter, creative, results-oriented, team player. Skilled in new product development. Seeking senior-level medical/scientific product development position. **Box number 96C**

Registered PE with BSME, MBA. 20+ years in aerospace, oil field/mining equipment, forged/mechanical parts, worldwide manufacturing, hands-on field engineering management, manufacturing process control. Used budgets of \$650 MM+, start-up/turn-around management skills, recruiting, training, structuring cost-efficient manufacturing, managed 500-4,000 employees, profits of \$MM+.

Ph.D in chemistry with 12 years industrial, national lab, postdoctoral experience. Broad background in physical, inorganic, and materials chemistry to address materials compatibility and develop for high temperature applications. Expertise in processing, thermal analysis, x-ray diffraction, crystal growth, and phase equilibria. Excellent written/oral communication skills. Tel: 804-525-7414. **Box number 98C**

Ceramic engineer. 14 years of R&D and operations management in ceramic catalyst carriers and mass transfer products. Responsible for experimental designs, TQM training, SPC training, team building, supplier-customer quality teams, and ISO 9000 preparation. Trouble-shooter for extrusion processing and sphere formation. Will relocate. Tel: 409-693-2214. **Box number 99C**

Ph.D experimental solid state physicist with 20 years of industrial and university R&D experience. Excellent communicator with broad background in ultrasonics, heat transfer, magnetics, and micro-electronic packaging. Adept at mathematics with computer modeling experience. Numerous patents and technical papers. Seeks industrial/university R&D position. Willing to relocate. **Box number 1D**

Graduate PE registered in six states and member of ASHRAE. 30+ years in all phases of engineering: management, construction, teaching, design, specification writing, marketing, sales and maintenance. Worked extensively with defense-related industry, heavy chemical plants, paper and pulp, cement, public health

engineering, water treatment plants, HVAC, plumbing and fire protection. **Box number 2D**

Ph.D in mechanical engineering with strong background in R&D of microelectronic packaging, hybrid microelectronics, SMT and through-hole manufacturing, mechanical behavior of materials, machine design, FEA, CAD, composite materials, experimental technique, stress analysis, fracture and fatigue, computer simulation, and thermal analysis. Seeks an academic or R&D position. **Box number 3D**

25 years in power generation, pipelines, pipeline compressor stations, rotating equipment and mechanical design engineering, technically oriented financial analysis, engineering sales, cogeneration, gas compressors (both reciprocating and centrifugal, including aerotypes), packaging of generator sets with gas turbines, natural gas fueled engines, and diesels for onshore/offshore. **Box number 4D**

Broadbrush technical/managerial professional in specialty chemicals seeks technical (product development, operations, technical service, quality, regulatory) or business (marketing, product management, sales, customer service, training) challenges. Expertise: pharmaceuticals, cosmetic materials, polymers, coatings, inks, pigments, food additives, and electromechanical equipment. **Box number 5D**

Strategic planner with 16 years in software, hardware and chemical industries. Enthusiastic, innovative, and hard-working professional with successful track record in corporate planning, research, product development, marketing, and sales. Expert planning ability, strong leadership skills and effective communicator who gets the work done. BS in business administration, MA in management. **Box number 6D**

Technical, energetic, creative front-line customer relations support engineer; BSEET. Solved down-time situations in the high-tech medical devices arena for over 8 years; dialysis, ultrasound, electroshock wave and pulse dye laser. Looking for a hands-on field operation to manage in the medical field, prefer lasers. Brad Gilmore, 1948 S. Gold St., Wichita, KS 67213-5039; Tel: 316-265-0069. **Box number 7D**

BS in aerospace engineering and BA in physics with two years experience in NDT design seeks position in aircraft or spacecraft subsystems R&D, Project leader for JSC ACRV design program in college. Good computer skills in FORTRAN, BASIC, Pascal, and CAD. Excellent communications skills and tenacious at problem solving. Willing to relocate. **Box number 8D**

BSEE graduate seeks position in digital or analog design. Strong interest in signal processing, control system design, optical engineering, and circuit simulation. Senior design project involved building transmitter/receiver radio. C programming, UNIX, FORTRAN, Pascal. Mathematica, Orcad, PV Waves, Autosketch, AutoCad. IBM PCs, Sun SPARCstation. Will relocate. Tel: 516-221-1442. **Box number 9D**

Retired Ph.D colloid chemist available for consultation. Has authored and edited several books and articles in refereed journals. Inventor of record on over 30 US and foreign patents in jet and rocket fuels, safety fuels, fire fighting emulsions, and emulsion breaking. **Box number 11D**

Recently graduated, MS in engineering materials. Seeking materials/manufacturing/quality engineering position. Publications, over 6 years experience in quality/manufacturing aerospace industry. Entry level for materials engineering. **Box number 13D**

To Request Resumes:

To obtain resumes corresponding to the above ads, fill out this form and mail to: Gregg McQueen, NASA Tech Briefs, 41 East 42nd St., New York, NY 10017; or call 1-800-944-NASA and ask for Gregg McQueen.

Send resumes for the following box numbers (limit 5):

Box _____ Box _____ Box _____

Box _____ Box _____

Name: _____

Company Name: _____

Street Address: _____

City/State/Zip: _____

HOW TO SIMPLIFY MOUNTING OF P.C. BOARDS



Specify PEM KEYHOLE® standoffs. They are designed so a PC board or panel can be quickly slipped into place and then removed from an assembly by simply sliding the board sideways and lifting it off. To secure the board or component against any unwanted movement, just use a standard PEM threaded standoff to accept a screw used with the keyhole standoffs. For your free self-clinching fastener guide and KEYHOLE® bulletin, circle the number below. For a complete PEM catalog contact Penn Engineering & Manufacturing Corp., Box 1000, Danboro, PA 18916. FAX: 215-766-0143 or CALL: 1-800-237-4736.

Clinch it with PEM
FASTENERS & PRESSES

For More Information Write In No. 503



FREE! 130 Page Catalog

"Optics for Industry"

Free 130 page product catalog from Rolyon, world's largest supplier of "Off-the-Shelf" optics. 24-hour delivery of simple or compound lenses, filters, prisms, mirrors, beamsplitters, reticles, objectives, eyepieces plus thousands of other stock items. Rolyon also supplies custom products and coatings in prototype or production quantities. **ROLYN OPTICS Co.**, 706 Arrowgrand Circle, Covina, CA 91722-2199, (818)915-5707, FAX (818)915-1379

For More Information Write In No. 505

EXPRESS

Best Value in the World for **POLYIMIDE & FR4**
1 to 5 DAY TURN
1 to 12 Layers
PRINTED CIRCUIT PROTOTYPES

2 PIECE PRICES FOR FR4 .062 Th.						
LAYERS	1	2	3&4	5&6	7&8	
SQUARE	15	\$233	\$292	\$639	\$787	\$935
INCH	30	264	330	724	891	1059
UP TO	60	311	389	853	1049	1137
	90	358	448	980	1207	1434
	120	385	486	1044	1311	1559

■ 5 PIECES x 1.34 ■ 5 DAY PRICES ABOVE
■ 10 PIECES x 1.67 ■ UL LISTED

EXTRAS **CAPABILITIES** **DISCOUNTS**

- Photo Plotting
- Testing
- Gold Contacts - \$50
- 25% - Below 8 Mil Hole
- Below 15 Mil Hole
- SMOBC & LPT - \$50
- Buried & Blind Vias
- Polyimide Multilayer
- Full Body Gold
- Carbon Paste
- Tin nickel burn-in boards
- SMT-SMOBC
- Up to 22 layers
- Impedance control boards

5% COD
10%

FOR MORE INFORMATION CALL OR FAX
Ken Bahl ■ 1108 W. Evelyn Ave., Sunnyvale, CA 94086
Phone (408)735-7137 FAX (408)735-1408 Modem (408)735-9842

For More Information Write In No. 506

4MEG VIDEO™ Model 12

Flexible Image Capture, Processing, & Display Board for the PC

- 8,000 - 4 Pixels per Line
- 16,000 - 1 Lines/Image
- 50MHz - 2 MHz Sampling & Display Rate
- Configurable 64, 16, or 4 MB Image Memory
- On-Board DSP
- Programmable Non-Standard, RS-170, & CCIR Video Formats
- Area or Line Scan Input
- Extensive Software

EPIX
381 Lexington Drive
Buffalo Grove, IL 60089
Tel / 708 465 1818
Fax / 708 465 1919
© 1994 - EPIX, Inc., U.S.A.

For More Information Write In No. 501

Motion Control

Windows, DOS & Macintosh

- PC/AT ISA Bus
- Macintosh NuBus
- DSP Based Servo
- MicroStepping
- 32 Bit Processor
- Digital I/O & Limits
- Free Windows S/W
- Great LabVIEW Vt's

Free Demo Disk Call: 617-444-7680

High Performance DSP Servo & Micro-Stepper Boards for PC/AT ISA Bus and NuBus. 1-4 axes of control with Powerful Servo Amps, Bipolar Stepper Drivers & Interface Units. **Easy-To-Use pcRunner** Windows software, DLLs, LabVIEW Motion VIs, Visual Basic Code, QuickBasic drivers and "C" motion libraries.

nuLogic
475 Hillside Ave • Needham • MA • 02194

For More Information Write In No. 504

RUGGED, HIGH PERFORMANCE AND LIGHT WEIGHT SYSTEM WITH FLAT PANEL VGA DISPLAY

ST-3000EL STANDARD FEATURES INCLUDE

- 12 SLOT PASSIVE BACK PLANE. 300W POWER SUPPLY
- 80486DX CPU CARD AT 50/66 MHZ. UP TO 32MB RAM
- 640x480 RESOLUTION. 16 GRAY LEVELS. 10" AMBER ELECTROLUMINESCENT DISPLAY
- 1.2 MB AND 1.44 FLOPPY DRIVES. DUST PROTECTED
- FIXED OR REMOVABLE HARD DISK FROM 200MB TO 2.1GB FULLY SHOCK AND VIBRATION PROTECTED

ALSO AVAILABLE WITH PASSIVE OR ACTIVE COLOR LCD VGA DISPLAY AND PENTIUM 60/66 MHZ CPU CARDS IN VARIOUS AND CUSTOM CONFIGURATIONS. FOR FURTHER DETAILS CONTACT:

IBI SYSTEMS INC. 6842 NW 20 AVE
FT. LAUDERDALE, FL 33309
305-978-9225 FAX: 305-978-9226

For More Information Write In No. 502

4 reasons you should use YSI thermistors

- NASA qualification
- ISO 9001 certification
- Packaged as standard or custom probes
- FREE Temperature Handbook

Call us at **800 765-4974.**

YSI INCORPORATED
Yellow Springs
Ohio 45387

For More Information Write In No. 507

PARIS AIR SHOW T-SHIRT

Only \$14.95 each.

Official commemorative T-shirt of the 40th Paris Air Show features a striking full-color design on a black shirt (design is on back of actual shirt). Adult sizes available.

Rush me ___ Paris Air Show T-shirts at \$14.95 each plus \$4.00 postage and handling. (NY residents add sales tax to total.)

Total Enclosed: \$ _____ (check or MO payable to NASA Tech Briefs)

Size(s): ___ S ___ M ___ L ___ XL

Name _____

Company _____

Address _____

City/St/Zip _____

Mail to: NASA Tech Briefs, Dept. F., 41 East 42nd St., #921, New York, NY 10017
For credit card orders call (212) 490-3999

Low Cost Miniature Controllers

Save time. Save money.

Our wide range of C-programmable miniature controllers are ideal for control applications, data acquisition, and test and measurement. Compact and low in price (the Little PLC™ above is 2"x3" and \$195), these controllers are programmed with our easy-to-use Dynamic C™ development system. Our controllers feature digital I/O, ADCs and DACs, relays and solenoid drivers, RS232 and RS485 serial ports, battery-backed memory and time/date clock, LCDs, keypads, enclosures and more!

1724 Picasso Ave.
Davis, CA 95616
916.753.0618. Call 916.757.3737
from your FAX. 916.753.5141 FAX

For More Information Write In No. 508

ADVERTISERS INDEX

3M Electrical Specialties Division (RAC 402,403)	49,51	Macysma Inc. (RAC 409)	16
Abaris Training Resources, Inc. (RAC 323)	88	The MacNeal-Schwender Corporation (RAC 422)	89
AC Engineering Systems, Inc. (RAC 356)	90	Master Bond, Inc. (RAC 422)	94
Accurate Screw Machine Company (RAC 325)	88	Mathworks, Inc. (RAC 641)	COV IV
Aegis Software Corporation (RAC 326)	88	MCM Electronics (RAC 367)	91
Algor, Inc. (RAC 518,341)	7,89	Merlin Engineering Works (RAC 426)	59
American Precision Industries (RAC 301,302)	86	Minco Products, Inc. (RAC 436)	92
AMP Incorporated (RAC 327)	88	Moritex USA, Inc. (RAC 352)	90
Anorad (RAC 328)	88	National Instruments (RAC 636)	COV II,
Anritsu Meter Co. of America (RAC 303)	86	Corporation 405,304)	44,86
Ansoft Corporation (RAC 638)	COV III	National Technology Transfer Center (RAC 408)	12
Astro-Med, Inc. (RAC 662)	11	Neslab Instruments (RAC 359)	91
Bancomm (RAC 346)	90	Networks Expo Dallas (RAC 640)	19
W.M. Berg Inc. (RAC 312,348)	87,90	New England Affiliated (RAC 347)	90
Bokers, Inc. (RAC 300)	86	Nordex Inc. (RAC 332)	88
Carr Lane Mfg. (RAC 310)	87	Northeast Photonics Commercialization Conference	98
Cherry Electrical Products (RAC 331)	88	Northwestern Tools, Inc. (RAC 333)	88
CM Furnaces Inc. (RAC 417)	59	nuLogic, Inc. (RAC 504)	96
Colder Products Company (RAC 335)	89	Numerical Algorithms Group (RAC 414)	37
Cole Parmer Instrument Company (RAC 314)	87	Pacific Scientific (RAC 340)	89
Contemporary Cybernetics (RAC 658)	5	Parker Hannifin Corp., Daedal Div. (RAC 318)	87
CPV Mfg., Inc. (RAC 306)	86	Patton & Patton Software Corporation (RAC 430)	15
Data Translation, Inc. (RAC 642)	21	Penn Engineering & Manufacturing Corp. (RAC 503)	96
Design Solutions Software Co. (RAC 321)	87	PIC Design (RAC 316)	87
Digi-Key Corporation (RAC 609)	3	Pittman (RAC 415)	24
Eaton Corporation (RAC 643)	9	Protective Closures Co., Inc. Caplugs Div. (RAC 329)	88
Edmund Scientific Co. (RAC 322)	88	Reid Tool Supply Company (RAC 334)	89
Elf Atochem North America, Inc. (RAC 330)	88	Remcor Products Company (RAC 339)	89
Elgiloy Limited Partnership (RAC 354)	90	RGB Spectrum (RAC 431)	8
Elmo Manufacturing Corporation (RAC 412)	39	Rolyn Optics Company (RAC 505)	96
Emcor Products (RAC 324)	88	Rosemount Aerospace (RAC 336)	89
EPIX, Inc. (RAC 501)	96	Science Accessories Corporation (RAC 404)	43
Evans (RAC 407)	10	Sekai Electronics of America (RAC 366)	91
Excel Quantronix (RAC 365)	91	Sierra Circuits, Inc. (RAC 506)	96
Fabco-Air Inc. (RAC 357)	90	Specialized Products Co. (RAC 337)	89
Felton Brush Inc. (RAC 368)	91	Spyglass (RAC 338)	89
Gage Applied Sciences, Inc. (RAC 423)	94	Stanford Research Systems (RAC 362)	91
Gaill Motion Control (RAC 307)	86	Strawberry Tree (RAC 401)	55
General Devices (RAC 428)	70	Structural Research and Analysis Corp. (RAC 353)	90
General Magnaplate Corp. (RAC 311)	87	Systran Corporation (RAC 317)	87
Graphite Metallizing Corporation (RAC 424)	97	Technology 2004	25-32
Hamilton Company (RAC 343,344)	89	Tektronix (RAC 406)	45
Hardigg Industries, Inc. (RAC 320)	87	Terra Universal Inc. (RAC 313)	87
Hewlett-Packard Company (RAC 639,416)	1,34,35	Thompson Casting (RAC 351)	90
Hi-Techniques, Inc. (RAC 360)	91	Trompeter Electronics Inc. (RAC 358)	91
IBI Systems, Inc. (RAC 502)	96	TrueTime, Inc. (RAC 315)	87
IEE/Inspec (RAC 425)	97	United Technologies Microelectronics Center (RAC 411,432)	38
Illbruck (RAC 435)	92	Universal Air Filter Company (RAC 421)	93
Illinois Instruments Inc. (RAC 361)	91	Vector Fields Inc. (RAC 364)	91
Indium Corporation of America (RAC 637)	13	Veeco/Sloan Technology (RAC 345)	89
Insaco, Inc. (RAC 363)	91	Visual Solutions, Inc. (RAC 427)	71
Intergraph Corporation (RAC 632)	2	Voltek, Div. of Sekisui America Co. (RAC 350)	90
IOtech, Inc. (RAC 413)	61	Yaskawa Electric America, Inc. (RAC 308)	86
Kalamazoo Technical Furniture (RAC 305)	86	Yokogawa Corporation of America (RAC 319)	87
Kaman Instrumentation (RAC 420)	93	YSI, Inc. (RAC 507)	96
Keithley Instruments, Inc. (RAC 355)	90	Z-World Engineering (RAC 508)	96
Kinetic Systems Corporation (RAC 349)	90	Zircar Products Inc. (RAC 429)	84
Knowledge Express (RAC 698)	17	Zygo Corporation (RAC 309)	91

*RAC stands for Reader Action Card. For further information on these advertisers, please write in the RAC number on the Reader Action Card in this issue. This index is compiled as a service to our readers and advertisers. Every precaution is taken to insure its accuracy, but the publisher assumes no liability for errors or omissions.

GRAPHALLOY[®] Since 1913

BUSHINGS WORK

—Where Others Won't



A Graphite/Metal Alloy to solve your bearing problems in hostile environments:

- Corrosive liquids and vapors
- Cryogenic to high temperatures
- Wet or dry

Anywhere grease, oil, or plastics are failing. You benefit from:

- Reduced maintenance
 - Superior performance...
- in equipment like pumps, ovens, mixers, screens, dampers, valves, plating and coating tanks, ...

What's YOUR bearing problem?

We have solutions for you! Call us!

GRAPHITE METALLIZING

CORPORATION

1050 Nepperhan Avenue, P.O. Box 110, YONKERS, NY 10702 U.S.A.

© 1994 K Tel: 914-968-8400 · FAX: 914-968-8468

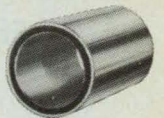

For More Information Write In No. 424

MATLAB[®] Toolboxes and Applications for Control

A.J. Chipperfield and P.J. Fleming (Eds.)

\$75.00

MATLAB[®] is a widely accepted tool for computer-aided design of control systems (and many other diverse computation applications) as its structure enables users to devise and customize toolboxes and applications. This book introduces MATLAB and describes the major control toolboxes. It features new work on nonlinear control software, a model-based expert system and PID tuning. Application-specific work describes how MATLAB is used in robotics, automotive and aerospace control system design. MATLAB is a registered trademark of The MathWorks, Inc.

251pp., 234x156mm, Casebound - 1993 ISBN: 0 86341 290 4 - CE048



IEEE Service Center
IEEE/INSPEC
445 Hoes Lane
Piscataway, NJ 08855-1331
Telephone: (908) 562-5553
Fax: (908) 562-8737

REGISTER NOW FOR

NORTHEAST PHOTONICS COMMERCIALIZATION CONFERENCE AND WORKSHOP

Creating New Business
Opportunities In Optoelectronics

SEPTEMBER 15-16, 1994

Sturbridge Host Hotel/Conference Center, Sturbridge, Massachusetts

Sponsored by:

- NASA Goddard Space Flight Center Office of Commercial Programs
- *Laser Tech Briefs*
- NASA Northeast Regional Technology Transfer Center — Center for Technology Commercialization

In cooperation with CONNECT: the New England Alliance for Photonics Technology Deployment

Photonics industry attendees at this one-and-a-half-day conference/workshop, the first in a planned series, will come face to face with advanced laser, optoelectronic, and imaging technologies developed initially for the space program that hold promise for commercial exploitation. The program will feature:

- Inventors and technical program managers from Goddard Space Flight Center in individual and roundtable sessions;
- Researchers, patent counsel, and technology transfer experts available for one-on-one discussions of commercialization opportunities;
- A "networking reception" for all participants on September 15.

BRINGING TOGETHER

From NASA Goddard Space Flight Center:

- Researchers and scientists from the Photonics Branch (Laser Ranging and Altimetry, Remote Sensing), Optics Research and Design Branch, Solid State Device Development Branch, Electronic Systems Branch (Data Processing, Signal Processing), Environmental Sensors Lab, and more.

From the Regional Photonics Industry:

- Designers, engineers, and technology managers whose companies are searching for innovative ways to develop and test new products, improve manufacturing/production processes, initiate new business lines.

For more information on attending, write in 692
on the Reader Information Request Form.

THE TECHNOLOGY CONNECTION

To Advertise Call (800) 944-NASA

Engineering & Scientific Software

SCIENTECH

For Engineering,
Scientific & Technical
Software...

The best value on over
1,500 products!

Call *Software for Science*
1.800.622.3345
for a free catalog!

SciTech Software for Science
2231 N. Clybourn Ave., Chicago, IL 60614
Ph 312.472.0444 FAX 312.472.0472 **SciTech**

Technology Transfer Publications

PUBLISHING IDEAS

Associated Business Publications is seeking contributors for a proposed series of newsletters and magazines focusing on a wide variety of technologies. Excellent profit sharing opportunity for experienced professionals with detailed knowledge in specific technical fields. Any technical field will be considered. We welcome your comments and suggestions.

Contact: William Schnirring, President,
Associated Business Publications,
41 E 42nd St., Suite 921, New York, NY 10017
Tel: 212-490-3999; Fax: 212-986-7864.

Contracting Opportunities

SBIR PROPOSAL-WRITER SOFTWARE

The SBA Small Business Innovation Research Program provides innovative research and development opportunities for small high tech firms. SBIR PROPOSAL-WRITER SOFTWARE assists firms in preparing winning proposals for Department of Defense SBIR Program contracts. The cost of the software is \$39.00. To order, send check to: Associated Business Publications, 41 East 42nd St., Suite 921, New York, NY 10017.

Call For Articles

Important Announcement For All Federal Laboratory Technologists & Contractors

Associated Business Publications is now accepting article submissions for the premiere edition of Federal Lab Tech Briefs, a new series of publications reporting on government-sponsored technologies for transfer in a variety of high-tech fields. The first edition, focusing on Test & Measurement innovations, will be published in November. For more information write in no. 431 or call Joe Pramberger at (212) 490-3999.

Call For Nominations

SBIR Technology Of The Year Awards

The first annual Small Business Innovation Research (SBIR) Technology of the Year Awards will be presented this November in Washington, DC in conjunction with the Technology 2004 national technology transfer conference & exposition. Phase II and III SBIR companies that have developed novel, commercially-important technologies and products through SBIR funding are invited to submit nominations and exhibit at Technology 2004. For a complete nomination package, write in no. 424 or call Wayne Pierce at (212) 490-3999.

NASA Tech Briefs, ISSN 0145-319X, USPS 750-070, copyright© 1994 in U.S., is published monthly by Associated Business Publications Co., Ltd., 41 E. 42nd St., New York, NY 10017-5391. The copyrighted information does not include the (U.S. rights to) individual tech briefs which are supplied by NASA. Editorial, sales, production and circulation offices at 41 East 42nd Street, New York, NY 10017-5391. Subscription for non-qualified subscribers in the U.S., Panama Canal Zone, and Puerto Rico, \$75.00 for 1 year \$125.00 for 2 years; \$200.00 for 3 years. Single copies \$10.00. Foreign subscriptions one-year U.S. Funds \$150.00. Remit by check, draft, postal, express orders or VISA, MasterCard, or American Express. Other remittances at sender's risk. Address all communications for subscriptions or circulation to NASA Tech Briefs, 41 East 42nd Street, New York, NY 10017-5391. Second Class postage paid at New York, NY and additional mailing offices.

POSTMASTER: please send changes to NASA Tech Briefs, 41 E. 42nd Street, Suite 921, New York, NY 10017-5391.

NASA Tech Briefs, August 1994



On Target!

Maxwell® SI Eminence solves your high-speed circuitry and EMI/EMC design problems.

Maxwell SI Eminence combines the signal integrity analysis and modeling power of Maxwell SI Spicelink with the ability to characterize full-wave radiative effects. Solve the whole spectrum of high speed design issues ranging from signal integrity to electromagnetic compatibility with a single integrated package.

Analyze EMC/EMI problems such as ICs, PCBs, cables and loops, cabinets, apertures, and radiating structures such as antennas (microstrip, wire, slot, horn).

Analyze Signal Integrity design issues including ground bounce, crosstalk, parasitic parameters, power and ground plane placement, and electromigration.

Don't miss the mark, call Ansoft for information on the Maxwell SI products.



Ansoft Corporation
Four Station Square
Suite 660
Pittsburgh, PA 15219-1119 USA
TEL (412) 261-3200
FAX (412) 471-9427
Internet: Slinfo@ansoft.com

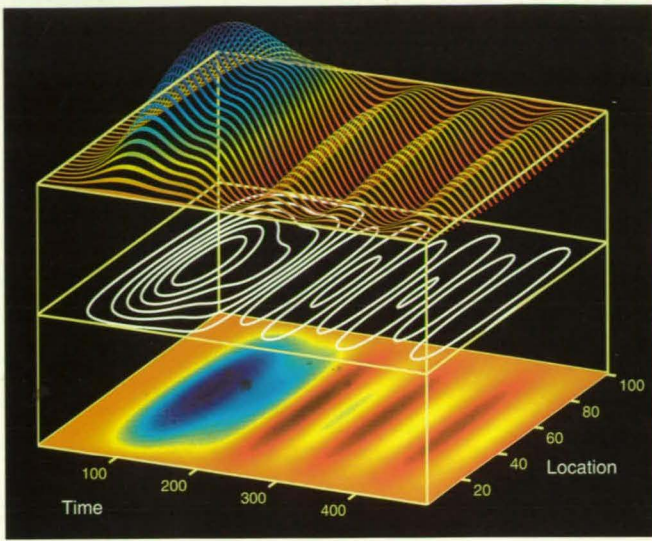

Three views of bending forces on a magnetic levitation train guideway. Analysis was one part of an 80th-order differential equation modeled with MATLAB. Data courtesy of Grumman Corp.

Add it all up— nothing else equals MATLAB® for technical computing.

When you need to solve tough technical problems, math is only part of the equation. MATLAB gives you math and more. It's a complete, extensible *technical computing environment* that provides computation, visualization, and application-specific toolboxes.

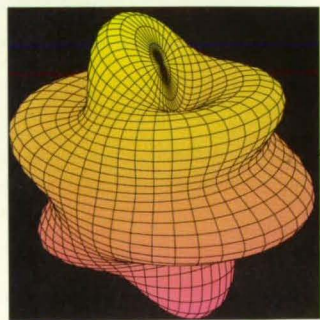

Visualization of a spherical harmonic function, created with the new Symbolic Math Toolbox.

High-performance numeric computation

MATLAB puts over 500 math, scientific, and engineering functions at your fingertips, all designed to deliver high-performance numeric computation to your desktop. With MATLAB, you can quickly and easily crunch huge data sets and evaluate complex models.

Stunning 3-D graphics to sharpen your insight

MATLAB's advanced 3-D visualization tools have no peer. They're interactive and tightly coupled to the math functions, so you can freely analyze, transform, and visualize.

A simple, powerful, open programming language

MATLAB is the natural language to express technical concepts, design algorithms, and prototype solutions. Rich with built-in functionality, MATLAB lets you develop technical applications in a fraction of the time it takes with Fortran or C.

Powerful GUI tools let you build intuitive, interactive displays, complete with sound and animation.

With MATLAB's open approach, you can inspect source code and algorithms, change existing functions, or create your own. You can also link MATLAB with your C or Fortran programs, exchange data with other applications.

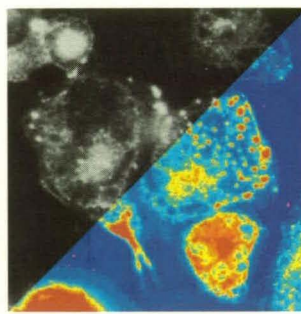

Enhancement of a cell micrograph using density slicing with the new Image Processing Toolbox.

Leading-edge toolboxes give you a head start

MATLAB Toolboxes are the product of world-class research in engineering and science. Easily combined and customized, toolboxes provide comprehensive collections of MATLAB functions for specialized application areas. The MATLAB toolbox family includes:

- Signal Processing
- System Identification
- Nonlinear Optimization
- Neural Networks
- Spline Analysis
- Control System Design
- Robust Control Design
- μ -Analysis and Synthesis

New MATLAB Toolboxes

Symbolic Math Toolbox

- High-performance symbolic algebra and calculus
- Equation solving and simplification
- Variable precision arithmetic
- Includes Maple V® kernel

Image Processing Toolbox

- Advanced 2-D filter design and filtering
- Color and morphological operations
- 2-D transforms
- Image analysis, enhancement, and restoration

Statistics Toolbox

- Interactive data analysis and graphics
- Descriptive statistics
- Regression analysis
- Probability modeling and random number generation

The Ultimate Technical Computing Environment™

MATLAB allows you to work and share your results across PCs, Macs, workstations, minicomputers, and supercomputers.

To learn how MATLAB accelerates the pace of discovery and development, call today and ask for your technical brochure:

508/653-1415

The
MATH
WORKS
Inc.

24 Prime Park Way/ Natick, MA 01760
Tel: 508/653-1415 Fax: 508/653-6284

Email: info@mathworks.com

Mosaic: <http://www.mathworks.com>

The MathWorks is represented in the following countries:
Australia: +61-2-922-6311 • Brazil: +55-11-816-3144
France: +33-1-45-34-23-91 • Germany: +49-241-26041
India: +91-80-2-260-260 • Israel: +972-3-561-5151
Italy: +39-11-24-85-332 • Japan: +81-3-5978-5410
Portugal: +34-3-415-49-04 • Scandinavia: +46-8-15-30-22
Spain: +34-3-415-49-04 • South Korea: +82-2-517-1257
Switzerland: +41-31-998-44-11 • Taiwan: +886-2-501-8787
For Belgium, Luxembourg, The Netherlands, United Kingdom and Republic of Ireland call Cambridge Control, Ltd: +44-223-423-200 or Rapid Data, Ltd: +44-903-821-266

MATLAB is a registered trademark of The MathWorks, Inc.