

270V Battery Using COTS NiCd Cells For Manned Spacecraft

Eric Darcy, NASA-Johnson Space Center, Houston, TX, USA

Frank Davies, Lockheed Martin, Houston, TX, USA

Leigh Hummer, AZ Technology, Huntsville, AL, USA

Brad Strangways, Symmetry Resources, Arab, AL, USA

Abstract

A high power (>35 kW at 215V), low capacity (5.2 Ah), and compact (45L) NiCd battery was developed for the X-38 Crew Return Vehicle (CRV), which is an experimental version of the lifeboat for the International Space Station (ISS). A simple design and innovative approach using a commercial-off-the-shelf (COTS) NiCd cell design enabled the design, qualification, and production of 4 flight units of this highly reliable and safe spacecraft battery to be achieved rapidly (2 years) and cheaply (\$1.7M).

Introduction

This battery powers the vehicle's electromechanical actuators, which move its flight control surfaces. The battery also powers the vehicle's winches, which steer its very large parafoil. The actuators require power peaks of > 35 kW (170A) for 100 ms each, delivered at a voltage exceeding 203V during the re-entry of the vehicle. The winches require sawtooth power peaks rising from 6 to 55A over 15 seconds maximum during steering maneuvers. Since the average baseline current of this battery is 6A for less than 45 minutes, less than 5.2 Ah are required from the battery. The location of the battery in the nose of the vehicle imposed very tight volume constraints (Figure 1). Each battery module could not exceed a width of 25.25" (64.1 cm), a height of 6.75" (17.1 cm), and a depth of 16.25" (41.3 cm). However, center of gravity requirements for the vehicle did not constrain battery mass.

The X-38 will be launched on a manned spacecraft (Space Shuttle) and is intended to demonstrate a point design for the operational lifeboat. Reliability and safety requirements impose a two-failure tolerance on both battery system performance and in preventing catastrophic hazards. Additionally, exposure to high voltage contacts external to the battery is prohibited. The reliability is achieved by providing 3 independent battery modules and 270V buses, each capable of the meeting all vehicle requirements. Cost and schedule constraints were challenging and prohibited any cell design development.

The high voltage requirement coupled with the low pressure environment during re-entry makes insulation breakdown due to corona discharge effects a very real concern, which required special attention to the electrical design and materials selection.

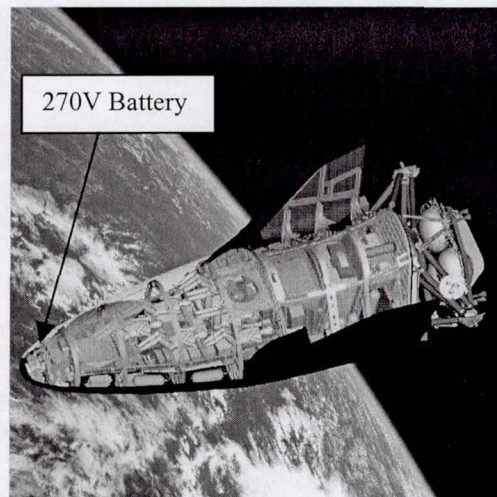

Figure 1. CRV with 270V battery in non-pressurized nose compartment.

Design Solution

The job of designing, assembling, qualifying and delivering the flight battery modules and ground support chargers for the X-38 was contracted by NASA-Johnson Space Center to AZ Technology, in Huntsville, AL, teaming with Symmetry Resources, in Arab, AL. Lockheed Martin helped define the design requirements of the battery electronics for NASA.

Cell selection – Short and long term cost drivers dictated the use of a standardized commercially available cell size that is available from multiple sources. Operationally, the CRV would be returned to earth for refurbishment after spending its required 3-years of service docked to the ISS. Therefore, over the 30-year life of the ISS, ten battery refurbishments are envisioned, requiring that the cell design selection must be made with prevention of obsolescence in mind. Several commercially available lead-acid, NiMH, and NiCd candidate cells were evaluated on the basis of capacity and pulse power test performance, and NiCd subC cells were found to be the building block cell with the smallest volume battery [1]. After further evaluation of NiCd subC cells from Sanyo Energy Corp, model number CP-2400SCR was down selected. This cell weighs 58 g and has a diameter of 22 mm and a height of 42.5 mm. It delivers 2.2 Ah at a C-rate to 1.0V at room temperature and kicks out 80A, 10s pulses and up to 20A continuously. Destructive physical analysis of cells revealed that the design utilizes sintered positive and negative electrodes with a nylon separator. The cell

vent consists of a disc backed with a spring. The insulator material of the crimp seal is nylon.

Battery Configuration – To perform within the 203 to 300V performance window and not exceed 300V during 85A charging pulses, strings of 210 cells in series are needed. These charging pulses can occur when aerodynamic forces accelerate the flight surfaces and result in regenerative pulses. To meet the capacity and power requirements, 4 parallel strings are needed. This configuration is shown in Figure 2 and yields at 8.8 Ah battery at a C-rate, room temperature discharge to 210V.

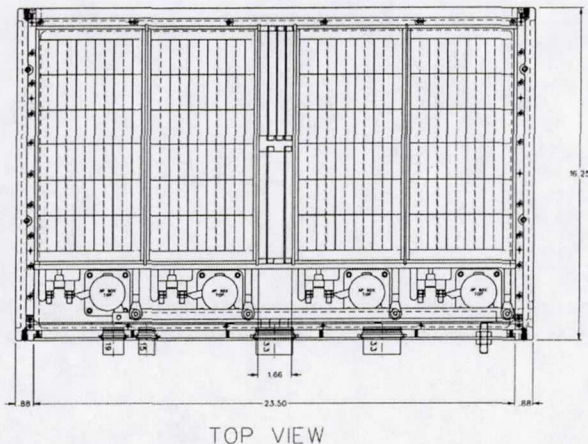

TOP VIEW

Figure 2. Top view of battery module showing the 4 strings each with 210 series cells along with shunts, and contactors in the front section.

Deadfacing – Since the output of this battery exceeds 42V, the high voltage connectors are required to be “deadfaced” to prevent accidental human exposure. This is achieved by placing contactors in series between the string power outputs and the external power connectors of the battery. In order to charge each string in the battery one at a time, each string is in series with a contactor (Model # Kilovac AP90X-09 from CII). A block diagram of the battery module is shown in Figure 3. The contactors require 28V input power to be closed and open whenever this power is removed. Furthermore, a series of jumper wire interlocks for the 28V power loop are embedded in each high voltage connector to preclude closing any contactors without all battery module high power connectors mated with their mates or safety caps.

Safety – The abuse tolerance of the selected cells was determined by short circuit, overcharge, reversal, and heat to vent tests. For each test, the polyvinyl chloride (PVC) shrink wrap provided by Sanyo was removed. The cell suffered very little external damage during all of these tests. No cell explosions, ruptures, or flaming vents occurred. In addition, the vent and burst pressure of the cell design was determined to be 190-310 psid and 800-850 psid, respectively. This was determined by drilling a hole in the side of the cell can and making a

connection to a nitrogen gas pressure system. The burst pressure was determined by a similar test but with the cell vent plugged with an epoxy adhesive. The results indicate that the cell meets NASA-JSC structural requirements for sealed containers in that the cell can design is leak-before-burst and its vent pressure < 2.5 x its burst pressure.

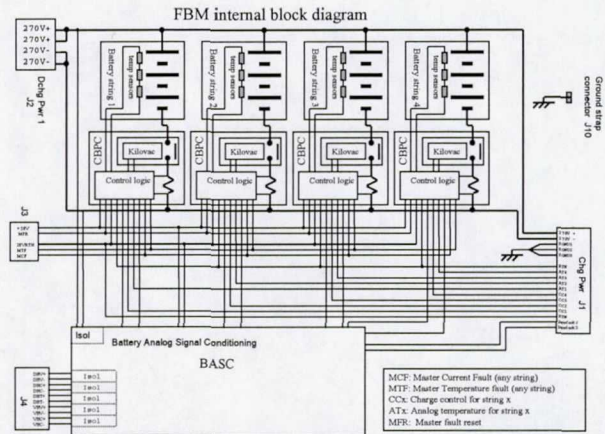

Figure 3. Block Diagram of the Flight Battery Module (FBM) showing 4 parallel cell strings isolated with contactors

Each contactor is controlled by a Circuit Breaker Power Control (CBPC) module which measures the string current and temperature and trips open when 50A and 80°C are exceeded, respectively. Note that the temperature threshold is only active during charging. Since this only provides one level of control for short circuit failure modes, the resulting hazard must not be a catastrophic hazard.

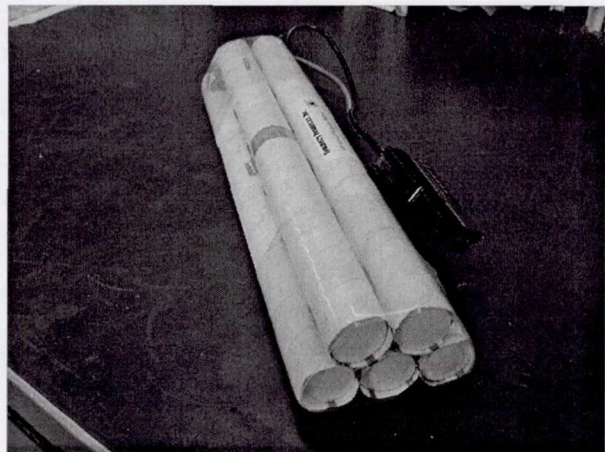

Figure 4. A 30 cell-in-series bundle consisting of 5 sticks of 6 series cells. This photo was taken after the short circuit.

Therefore, this battery design depends on proper high temperature (200 °C) material selection for the construction of the cell strings to limit the hazard of short circuit to cells venting or leaking KOH electrolyte. With this approach, shorted cells get hot but do not cause a propagation of more short circuits due to

melting or burning materials external to the cells in the battery. No fire, flame, cell rupture, or explosion is permissible. This result was demonstrated through a short circuit test of a 6-cell stick at 5 mohms and a 30 cells-in-series bundle at 105 mohms (Figure 4). Peak currents of 240A and maximum temperatures of 140 °C were achieved with the cells venting mostly water vapor and without incurring any external damage.

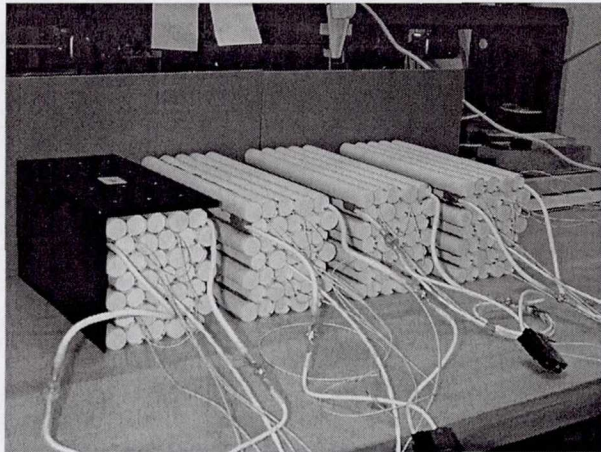

Figure 5. Four 210-cell strings.

Strings of 210 cells were assembled by stacking and gluing 7 of 30-cell bundles into tight packages as shown in Figure 5. A top and side aluminum plate were adhered to the strings to add strength and help with heat dissipation when in the battery module housing.

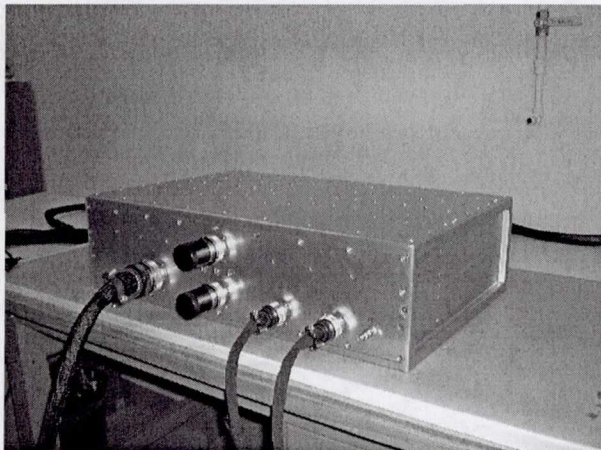

Figure 6. The 270V NiCd qualification battery module.

Corona Mitigation – Special precautions taken to mitigate corona discharge arcing which leads to insulation breakdown include

- (1) Eliminating sharp edges on conducting surfaces on all bus bars and shunts
- (2) Proper wiring (size, type, insulation type and thickness, termination)
- (3) Proper conductor shielding, separation, routing, and placement
- (4) Selecting lowest outgassing materials possible
- (5) Minimizing gaseous leaks or vents

- (6) Proper ventilation of battery housing to prevent trapping any gases

Charging – The battery modules are recharged one string at a time at C-rate using a reverse pulse charge waveform terminating on a voltage inflection or a temperature slope. Switching from string to string is achieved automatically via a programmable logic controller which monitors the charge termination control status. Each string receives a “Fast Charge”, followed by a second “Fast Charge/Topping Charge” to ensure each string is fully charged. Both charge regimes are sequenced to minimize string overheating. This charging process is completed by connected the battery to a Ground Support Equipment (GSE) charger. The GSE charger also has the necessary resistive load banks to discharge the battery module and perform internal resistance measurements.

Cell Acceptance

Over 5700 cells were screened to enable the assembly of the 5 battery modules, perform cell lot qualification tests, and have spare cells for engineering assemblies of 30-cell bundles. The plan for acceptance, shown in Figure 7, includes 100% screens for capacity, internal resistance, self-discharge, overcharge tolerance, leakage, mass, dimensions, and visual appearance. Overall, the performance of the lot was very homogenous [2]. Average C-rate discharge capacity was found to be 2.247 Ah with a standard deviation of 0.040 Ah (or 1.8%). The average internal resistance determined with a 100 ms, 24A pulse was found to be 5.211 mohms with a standard deviation of 0.169 mohms (or 3.2%).

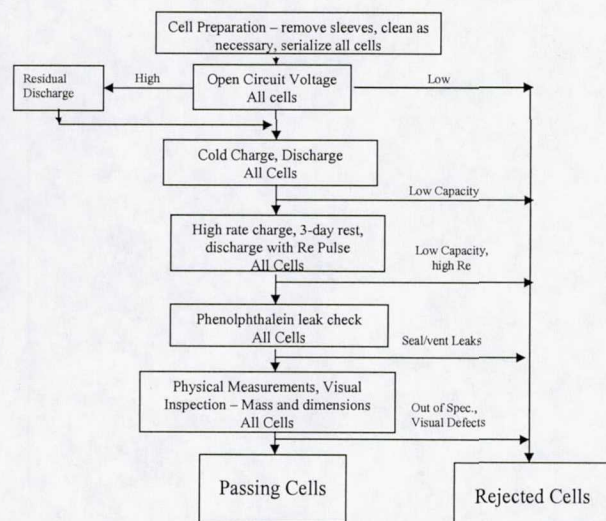

Figure 7. Cell acceptance flow chart.

Only 9 cells were rejected due to reasons other than visual discrepancies. Specifically, 2 cells each failed the initial capacity test and the leakage test, 1 cell each failed the self-discharge test and internal resistance test, and 3 cells failed the height dimensional test presumably due to bulging caused by poor recombination kinetics during overcharge.

The leakage test is achieved by cold charging the cell at C/10 for 16 hours at 0 °C which causes pressure build-up by reducing the kinetics of oxygen recombination.

The pressure stresses the seals of the cell and leakage is detected with a phenolphthalein indicator for KOH. We arrived at this method by performing a series of charge tests with cells connected to pressure transducers. The connection was achieved at the center of the bottom of the cell can and great care was taken to minimize the increased cell void volume by the plumbing. Figure 8 shows that equilibrium pressures of 47 to 61 psia were achieved on three separate N-1900SCR cells from Sanyo. This cell design was the precursor to the CP-2400SCR design.

These results are a good agreement with a snapshot measurement of cell pressure after 16 hours. In that independent experiment on the same cell design, cell pressures averaged 67 psia and were taken immediately after the 16-hour charge by puncturing the cell to measure its internal pressure at that state-of-charge.

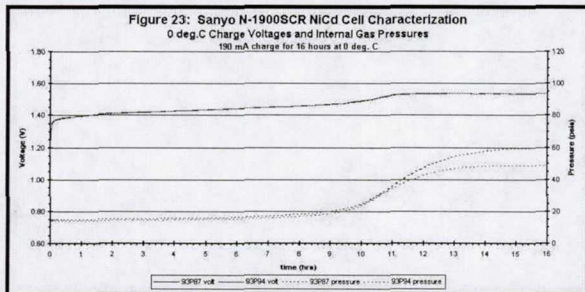

Figure 8. Voltage and cell pressure during a C/10 charge at 0 °C for 16 hours with the Sanyo N-1900 SCR cell.

Since the cell vent begins to operate at 190 psia, the 67 psia means that the cells are in essence proof tested at only 1/3rd of the vent pressure. However, this test creates a pressure differential across the cell seals that is four times greater than the 15 psid that the cells will see in space vacuum storage.

Interestingly, lowering the temperature to -15 °C during the C/10 charge test, produced lower equilibrium pressures than at 0 °C. Furthermore, with C-rate charging at room temperature, after 100 minutes equilibrium pressures of 95 to 116 psia were achieved with cell temperatures reaching around 45 °C, but is considered detrimental to the cell performance, and thus, not appropriate for acceptance of flight cells.

Battery Performance

Acceptance tests of the 210 cell strings to ¼ of the battery mission profile indicate that the design driving pulse is the last 170A EMA pulse. At a string level, these 42A, 100 ms pulse which occur every 1 second over a 240 second period, cause the voltage to sag to 215V when testing within hours after recharging. As shown in Figure 9, a 14-day rest period after the last

charge, causes a noticeable voltage depression and capacity degradation which causes the minimum voltage to sag to 208V under the same current profile.

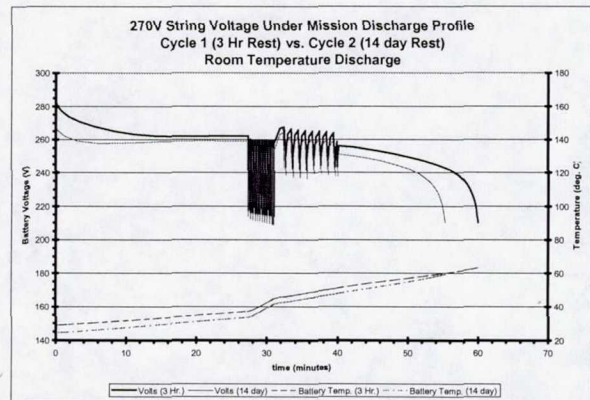

Figure 9. Comparison 210-cell string discharge voltage performance under the mission profile with a 3-hour and 14-day rest after the last recharge.

A thermal analysis of the battery module for the anticipated worst case hot case (re-entry) indicates the cell temperature should not exceed 70 °C, with the boundary condition imposed and using cell heat capacity and heat generation determined by calorimetry at Sandia National Labs [3]. The module's large mass (187 lbs) provides it with adequate thermal capacitance. This will be verified during environment testing under this worst case hot condition.

Conclusions

The battery design approach utilizing small commercial cells as the building block cell can be successful for demanding aerospace applications like the CRV for the ISS. This approach saves considerable development time because it utilizes a commercially established cell design that requires no further development. The approach also increases reliability because the failure of one cell would only cripple ¼ of the battery module rather than the same failure in a single string battery approach. Lots of the selected commercial cell from Sanyo performed with very little cell-to-cell variations.

References

- [1] High Power Commercial Cell Evaluation for the Crew Return Vehicle, SRI report, Job #78C, 1997.
- [2] Cell Acceptance Testing, SRI report Job #11X, 2001.
- [3] Thermal Property Measurements of SubC Ni/Cd Cells for the X-38 Crew Return Vehicle, E.P. Roth and E. Darcy, 2002 Power Sources Conference, Cherry Hill, NJ, 2002.