

# NASA Tech Briefs

*The Design/Engineering Technology Digest*

**Technology  
2005: The  
Future on  
Display**

**Focus on  
Sensors**

**Advanced  
Computing: New  
Alternatives To  
Traditional Techniques**

ABX 7962  
JOHN F. KENNEDY SPACE CENTER LIBRARY  
DOCUMENTS DEPARTMENT  
CIRCULATION COPY





**Test and Measurement**

"Programming in LabVIEW reduced the development time of our system from the expected 16 months to four months and allowed us to quickly make changes to our system."

Keith Simmons  
Electrical Engineer

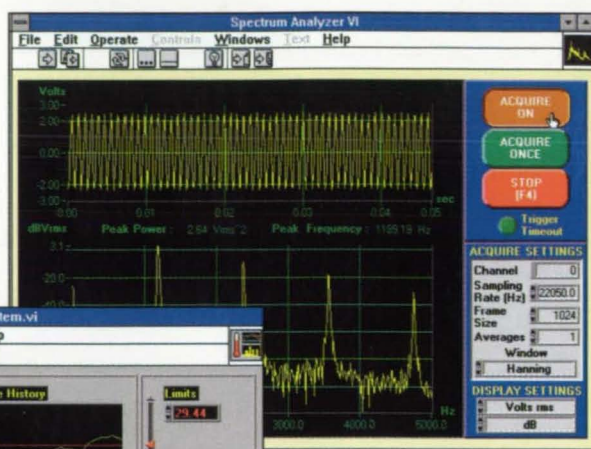

**Virtual Instrumentation**

"LabVIEW handles the 'nuts and bolts' of computer programming without my knowledge of the details. That makes it what I call an engineer's and scientist's programming language."

John O'Neal  
Laboratory Automation Specialist

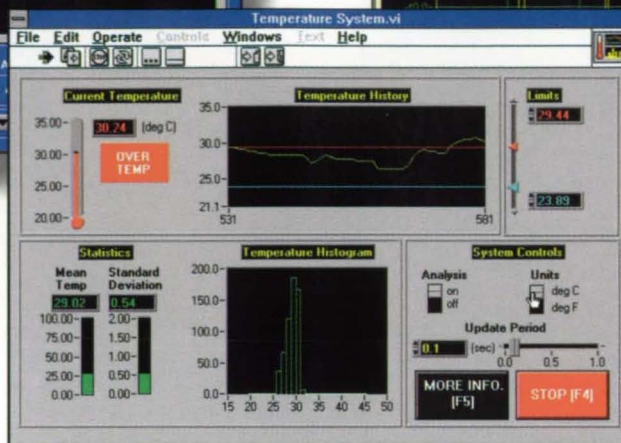

**Process Monitoring and Control**

# LabVIEW<sup>®</sup>

## Proven Productivity for Your Industry

To increase productivity and reduce time to market, you need software that's easy to use, yet versatile enough to handle your demanding applications. Whether you're in research, production, automation, or test, the key to success is software – software that empowers your organization to build higher quality products faster and for less money. That's where LabVIEW comes in.

### Software Innovation – for Your Applications

LabVIEW, the leading graphical programming language, gives you the software to automate your measurement, control, and analysis applications. LabVIEW pioneered Virtual Instrumentation almost a decade ago and continues to deliver proven productivity through breakthrough innovations and years of customer feedback.

### Flexible I/O – for Your Instrumentation

LabVIEW communicates with thousands of I/O devices, including our complete line of data acquisition hardware, GPIB and

VXI instruments, serial devices, PLCs, and much more. Take advantage of the hundreds of instrument drivers and ready-to-run programs included with LabVIEW.

### Solutions Worldwide – for Your Industry

Today, LabVIEW is making a difference in many industries, including automotive, telecommunications, semiconductor, electronics, aerospace, chemical, and education. Industry leaders worldwide use LabVIEW because it delivers proven productivity over and over again. For specialized needs, hundreds of third-party Alliance Program companies are ready with their LabVIEW expertise.

If you want to learn more about LabVIEW, give us a call. We'll show you how you can benefit from the graphical programming power of LabVIEW – **It's Proven Productivity for Your Industry.**



Call (800) 433-3488  
today for **FREE** LabVIEW  
demo software.



**U.S. Corporate Headquarters:** Tel: (512) 794-0100 • Fax: (512) 794-8411 • E-mail: info@natinst.com • WWW: http://www.natinst.com

**Branch Offices:** Australia 03 9 879 9422 • Austria 0662 45 79 90 0 • Belgium 02 757 00 20 • Canada 519 622 9310 • Denmark 45 76 26 00  
Finland 90 527 2321 • France 1 48 14 24 24 • Germany 089 741 31 30 • Hong Kong 2645 3186 • Italy 02 48301892 • Japan 03 5472 2970  
Korea 02 596 7456 • Mexico 95 800 010 0793 • Netherlands 03480 33466 • Norway 32 84 84 00 • Singapore 2265886 • Spain 91 640 0085  
Sweden 08 730 49 70 • Switzerland 056 20 51 51 • Taiwan 02 377 1200 • U.K. 01635 523545

© Copyright 1995 National Instruments Corporation. All rights reserved. Product and company names listed are trademarks or trade names of their respective companies.

**For More Information Write In No. 503**



- ✓ Special Edition for Purchasing Agents
- ✓ Over 3,100 Full-Color Pages
- ✓ Expanded Comprehensive Subject and Part Number Indexes
- ✓ Thousands of New Exciting Products
- ✓ Complete Ordering Information and Prices Included

**PURCHASING AGENTS!**  
**REQUEST YOUR FREE**  
**2-VOL. SET OF**  
**OMEGA'S PURCHASING AGENT**  
**EDITION TODAY!**

Circle No. 615 for Handbook request form or request Document #9993 from the OMEGafax<sup>SM</sup> Service

# OMEGA Proudly Announces the Arrival of our Newest Editions!

More Than 40,000 Items Offered for Process Measurement and Control with Prices and Ordering Information

**OMEGAfax<sup>SM</sup>**

OMEGA's 24-Hour-a-Day, On-Demand Publishing Service  
**Dial 1-800-848-4271**

from any Touch-Tone phone, and just enter document # 9993. A Handbook request form will be sent to you automatically. Don't forget to have your fax number handy!

For Sales and Service Call:

**1-800-82-66342<sup>SM</sup>**  
**1-800-TC-OMEGA**

**OMEGA Engineering, Inc.**

One Omega Drive, P.O. Box 4047  
 Stamford, CT 06907-0047  
 Tel: (203) 359-1660 Fax: (203) 359-7700

© COPYRIGHT 1996 OMEGA ENGINEERING, INC. ALL RIGHTS RESERVED.



**NEW!**  
 See OMEGA on  
 The WORLD WIDE WEB!

**OMEGAnet<sup>SM</sup>**  
 ON-LINE  
 SERVICE

<http://www.omega.com>



**Ω OMEGA<sup>®</sup>**

# The Answers to Your Questions...

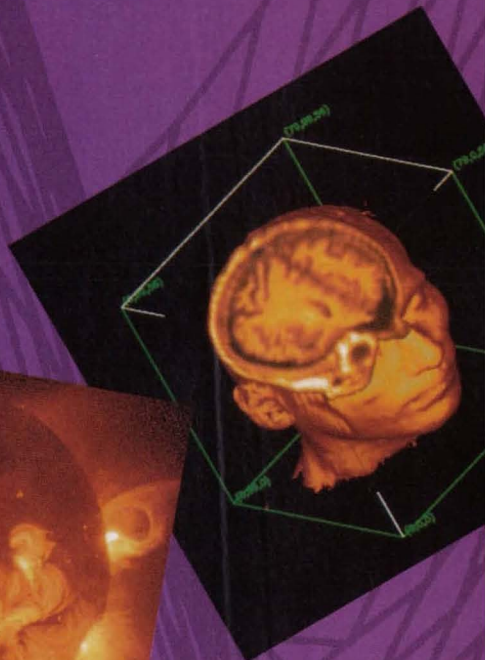
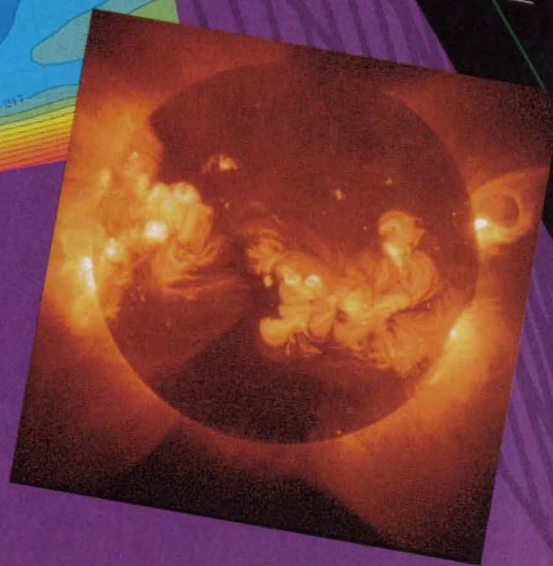
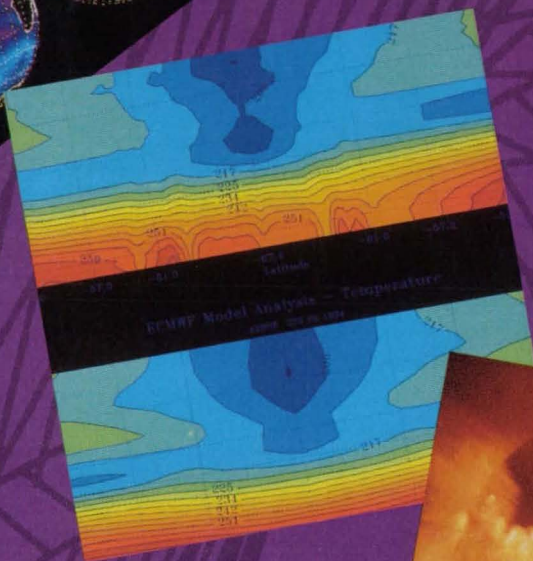
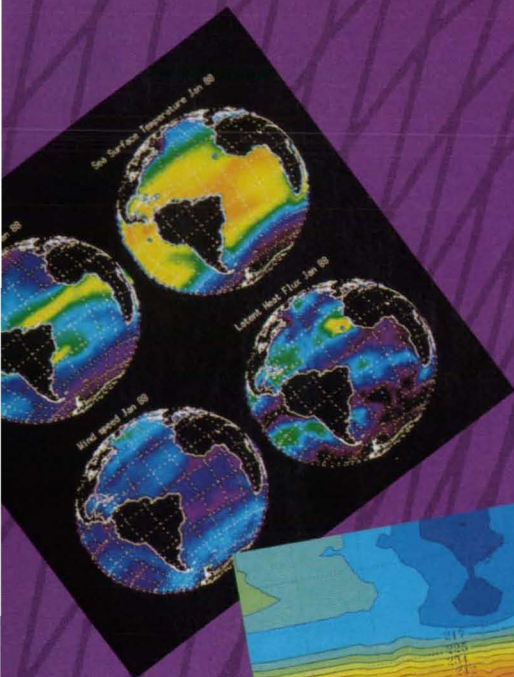

 IDL<sup>®</sup>

Immediately gain insight from your data with IDL, the pioneering software for interactive analysis and application development. If you analyze data from tests, experiments, simulations, or images – or write applications for others to use – IDL will give you clear results faster.

Dramatically improve your productivity using IDL for visual data analysis, rapid prototyping, or application development. Nothing else provides the speed, flexibility, and breadth of built-in functions for access, manipulation, and display of scientific and engineering data.

See results "on the fly" with integrated

graphics, image processing, mathematics, and statistics. Quickly turn your ideas into powerful applications using IDL's high-level, array-oriented programming language and cross-platform GUI tools.

A few lines of IDL code can do the job of hundreds of lines of C or Fortran, without sacrificing flexibility or performance. Plus, you can call functions in other languages or link IDL to your C or Fortran applications.

IDL programs are portable. You can deliver complete solutions on UNIX<sup>®</sup>, VMS<sup>™</sup>, Windows, Windows NT<sup>™</sup>, Macintosh<sup>®</sup>, and Power Macintosh, while writing programs only once.

So why waste time starting from scratch? Exploit IDL and find the answers – in less time, with less programming, and less hassle.

## SEE THE ANSWERS FOR YOURSELF

For a free evaluation copy, call

**303-786-9900**

Email: [info@rsinc.com](mailto:info@rsinc.com)/Fax: 303-786-9909

Software  Vision<sup>..</sup>



**Research Systems, Inc.**

2995 Wilderness Place  
Boulder CO 80301

Research Systems, Inc. is represented by the following distributors: **GERMANY** CREASO, GmbH 49 8105 25055 • **FRANCE** Fast Parallel Solutions 33 1 46 87 25 22 • **UK** Floating Point Systems UK Ltd. 44 734 776333  
• **ITALY** Alliant Computer Systems SRL 39 39 6091766 • **JAPAN** Adam Net Ltd. 81 35802 2251 • **BRAZIL** SulSoft 55 51 488 22 57 • **KOREA** InterSys 82 42 869 4746

For More Information Write In No. 577

# A World of Possibilities



Call, write, fax or  
visit us on the Internet  
for your  
**FREE CATALOG today!**

# Digi-Key

**1-800-344-4539**

Digi-Key Corporation  
701 Brooks Ave. South  
Thief River Falls, MN 56701  
Fax: 218-681-3380

<http://www.digikey.com>

For More Information Write In No. 532

**Your Ultimate Source For  
Quality Electronic Components!**

- #1 for Availability of Product
- #1 for On-Time Delivery
- #1 for Overall Performance



On orders placed by  
5:00 pm central time.

# WHO DOESN'T USE OUR DC/DC CONVERTERS?

Hughes does.

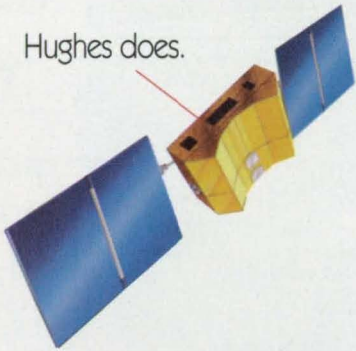

McDonnell Douglas does.

Rockwell does.

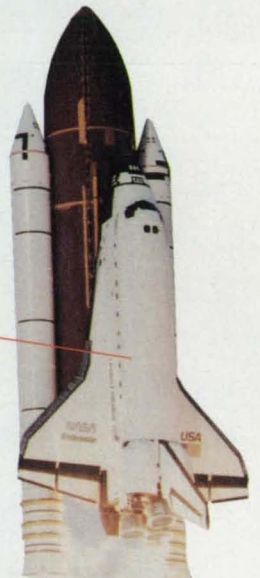

Lockheed Martin does.



**Them.**



Boeing does.



Loral does.



**If you ever had any doubts** about which converters to spec, rest assured our customers haven't. They're some of the biggest names in defense and aerospace. And you can bet they've done their homework.

We have over 60 DC/DC products on the DESC/SMD source list. All types have been tried and tested in mission-critical applications. Our AHE 2800, AHF 2800, ATO 2800 and ATW 2800 Series devices offer single, dual and triple-channel designs, with power outputs from 5 to 120 watts. And we manufacture in an automated MIL-STD-1772 certified facility with full military screening.

For details on our models, call (408) 988-4930 or fax (408) 988-2702. And if you've got an application we don't fit, don't worry. Chances are we're working on it.

**LAMBDA**  
Advanced Analog Inc. 

# Make quick cash from surplus test equipment.



## FREE TEST EQUIPMENT CATALOG

RF & microwave equipment, spectrum analyzers, synthesizers, oscilloscopes, environmental chambers, power supplies and more!

Calibrated & NIST Traceable Used Equipment,  
Factory Authorized New Equipment

## RAG Buys Test Equipment

To sell test equipment  
you're no longer using,  
call RAG  
and ask for purchasing.

RAG Electronics, Inc.

# 1-800-590-3457

To order a FREE catalog call...  
2450 Turquoise Circle, Newbury Park, California, U.S.A. 91320-1200 • FAX 805-498-3733 • Tel: 805-498-9933  
For More Information Write In No. 508

# Contents

**NASA** Tech Briefs

Official Publication of the National  
Aeronautics and Space Administration

## FEATURES

### 20 Technology 2005 Show Roundup

## TECHNICAL SECTION

### 24 Special Focus: Sensors



- 24 Reducing Tilt-Related Errors of Inductive Proximity Sensors
- 26 Fiber-Optic Differential Displacement Sensor
- 28 Advanced Triangulation Displacement Sensors
- 29 CMOS Active-Pixel Image Sensor With Intensity-Driven Readout
- 32 High-Speed Binary-Output Image Sensor

### 34 Electronic Components and Circuits



- 34 Ion-Accelerator Grids With Elongated Holes
- 35 Lightweight Cathodes for Nickel Batteries
- 38 Megavolt, Multigigawatt Pulsed Plasma Switch
- 40 Mode Orientation Control for Sapphire Dielectric Ring Resonator
- 40 Perforated-Layer Implementation of Radio-Frequency Lenses
- 42 Coding for Increased Density of Binary Data Stored on Disks
- 44 Hybrid-Circuit Module for dc-to-dc Power Converter
- 44 Thin-Ribbon Tapered Couplers for Dielectric Waveguides

### 46 Electronic Systems



- 46 Automatic Phase-Compensation Modules for Antennas
- 50 Measuring Motor-Shaft Clearance and Wobble During Operation

### 52 Physical Sciences



- 52 Phase-Conjugate Mirror Removes Wave-Front Distortions
- 54 Liquefaction of Coal With Surfactant and Disposable Catalyst

- 55 Computing Noise Temperature in a Beam Waveguide
- 56 Water-Repellency Probe
- 56 Apparatus Tests Peeling of Bonded Rubbery Material
- 58 Mass-Flow-Meter Leak-Testing System
- 60 Oven Evaporates Isopropyl Alcohol Without Risk of Explosion
- 60 Oxygen-Mass-Flow Calibration Cell

### 62 Materials



- 62 Polyimides That Contain Pendent Siloxane Groups
- 64 Cleaning Spectralon™ to Maintain Reflectance Properties

### 65 Computer Programs



- 65 Program Simulates a Modular Manufacturing System
- 65 Program Computes Receiver Gain and Noise Profiles
- 66 Quantifying Danger to Spacecraft Crews From Orbital Debris
- 66 Windowing System for Test and Simulation

(continued on page 8)



Following the presentation of his Keynote Address at Technology 2005, held October 24-26, NASA Administrator Daniel Goldin (left) toured the exhibits hall to view the latest design and engineering innovations on display. Robert Moreland of NASA's Johnson Space Center describes the function of the Left Ventricular Assist Device (LVAD) developed at JSC. For highlights from the sixth annual technology transfer conference and exposition, see page 20.

Photo by Bill Ingalls/NASA



# Make Short Work Of Backup With 200 MB Per Minute Speed.



The CY-8505 is the latest in a long line of 8mm tape drives that have provided reliable, unattended backup to businesses worldwide. Backwards compatible with all earlier models and scalable to a 2.8 TB library, the CY-8505 gives you something that's nice to find in the computer industry: *investment protection*.

The CY-8505 can store 7 GB on a single tape — up to 35 GB with hardware data compression. Two or more drives can work together with our Advanced SCSI Processor to give you *striping, mirroring, off-line copy/verify, cascade, and independent* modes of operation — and speeds of up to 200 MB per minute. Or, choose a tape library for unattended backup of *terabytes* of data.

Plug compatible with virtually every computer system, our 8mm tape drives offer more than performance in a custom configuration.



Our CY-8505 can store up to 7 GB native, up to 35 GB with data compression.

**Need to access files quickly?**  
We offer Accelerated File Access.

**Need hands-free control  
of a tape library?**  
We've got the Robotic Control Software to do it.

**Need to protect sensitive data?**  
It's as simple as adding  
Data Encryption.

## True Compatibility With:

Alliant	Parallel Port
Alpha Micro	PC 386/ix
Altos	PC MS-DOS
Apollo	PC Xenix/Unix
Arix	Pertec
AT&T	PICK
Basic-4	Plexus
Concurrent	Prime
Convergent	Pyramid
Data General	Sequent
DEC	Silicon Graphics
Gould/Encore	STC
HP	Stratus
IBM	Sun
ICL	Texas Instruments
Intergraph	Unisys
Macintosh	Ultimate
McDonnell Douglas	Wang
Motorola	Windows NT
NCR	- and more
NeXT	
Novell	
OS/2	
PS/2	

With a MTBF of 160,000 hours and a bit error rate of less than 1 in  $10^{17}$ , our subsystems give you unbeatable reliability and data integrity.

Easy to cost-justify and backed by a two year warranty that includes unlimited in-house technical support from our



Our CY-CHS10A features one or two tape drives and can store up to 385 GB on eleven tapes—without tape handling

engineering group, there's no smarter way to store data — today and tomorrow — than the family of CY-8505 tape subsystems.

Call today  
for a custom  
configuration and quote at...  
**(804) 833-9000.**

## CYBERNETICS

Tera One • Yorktown, Virginia 23693  
Fax: (804) 833-9300

# Contents *(continued)*

## DEPARTMENTS

NASA Commercial Technology Team .....	14
New Product Ideas .....	16
New on the Market .....	83
New Literature .....	84
New on Disk .....	85
Advertisers Index .....	87

### 68 Mechanics



- 68 SR-71 Experiment on Propagation of Sonic Booms
- 70 Assembling Precise Truss Structures With Minimal Stresses
- 72 Mechanism Attaches to Special Fixture
- 73 Rod Has High Tensile Strength and Low Thermal Expansion

### 74 Machinery/Automation



- 74 Jet-Engine Exhaust Nozzle With Thrust-Directing Flaps
- 75 High-Current Rotating Contactor
- 75 Aqueous-Spray Cleaning System

### 76 Manufacturing/Fabrication



- 76 Ultrasonic Inspection of Welds on Tube Fittings
- 76 Push/Push Fastener
- 78 Adhesion Casting in Low Gravity

### 79 Mathematics and Information



- Sciences**
- 79 Fast Neural Solution of a Nonlinear Wave Equation
- 80 An Efficient Variable-Length Data-Compression Scheme

### 82 Books and Reports



- 82 Improvement in Ball-Screw Linear Actuators
- 82 Space-Suit-Sizing Device

### 1a-8a Federal Laboratory Computing Tech Briefs

- 1a CyberSight True 3D Motion Imaging System
- 2a Development Tool to Improve Information Integration and Management
- 4a Computer-Assisted Trolley Fault Detection Using Neural Networks
- 6a Interactive Manufacturability Analysis and Critiquing System (IMACS)
- 6a Mobile Robot Radiation Mapping (RADMAP)
- 7a Reviewer's Assistant Helps Find Potential Design Problems

#### ***On the cover:***

*Using innovative computational approaches combining quantum and classical mechanics methods, the behavior of enzymes can be simulated. The 3D atomic structure for malate dehydrogenase (MDH) at the energy barrier or transition state for the proton transfer was simulated at Cornell University's Theory Center by Paul Bash of Argonne National Laboratory. See the special supplement of Federal Laboratory Computing Tech Briefs following page 64 for more computing advances.*

(Visualization by Richard Gillilan)  
Photo courtesy of Cornell Theory Center

This document was prepared under the sponsorship of the National Aeronautics and Space Administration. Neither Associated Business Publications Co., Ltd. nor the United States Government nor any person acting on behalf of the United States Government assumes any liability resulting from the use of the information contained in this document, or warrants that such use will be free from privately owned rights. The U.S. Government does not endorse any commercial product, process, or activity identified in this publication.

Permissions: Authorization to photocopy items for internal or personal use, or the internal or personal use of specific clients, is granted by Associated Business Publications, provided that the flat fee of \$3.00 per copy be paid directly to the Copyright Clearance Center (21 Congress St., Salem, MA 01970). For those organizations that have been granted a photocopy license by CCC, a separate system of payment has been arranged. The fee code for users of the Transactional Reporting Service is: ISSN 0145-319X/94 \$3.00+.00

NASA Tech Briefs, ISSN 0145-319X, USPS 750-070, copyright © 1996 by Associated Business Publications Co., Ltd. Copyright is not claimed for the individual "tech briefs" contained in this publication. The U.S. Government has a paid-up license to exercise all rights under the copyright claimed herein for governmental purposes. NASA Tech Briefs is published monthly by Associated Business Publications Co., Ltd., 317 Madison Ave., Ste. 921, New York, NY 10017-5391. Editorial, sales, production, and circulation offices at 317 Madison Ave., New York, NY 10017-5391. Subscription for non-qualified subscribers in the U.S., Panama Canal Zone, and Puerto Rico, \$75.00 for 1 year; \$125 for 2 years; \$200.00 for 3 years. Single copies \$10.00. Foreign subscriptions one-year U.S. Funds \$150.00. Remit by check, draft, postal, express orders or VISA, MasterCard, and American Express. Other remittances at sender's risk. Address all communications for subscriptions or circulation to NASA Tech Briefs, 317 Madison Ave., New York, NY 10017-5391. Second-class postage paid at New York, NY and additional mailing offices.

**POSTMASTER: Please send address changes to NASA Tech Briefs, P.O. Box 10523, Riverton, NJ 08076-0523**

# For Information on Finite Element Design and Analysis



Stop by Our Place

# WWW.ALGOR.COM

Algor's Internet Home is the fastest way to find out about:



Houdini: CAD/FEA Integration with 8-node "Bricks"



Finite Element Design and Analysis Software



Plant and Piping System Design and Analysis Software



Multimedia Products for Engineers (books, videos, etc.)



Speed-Mesh: CAD to 8-node "Brick" Modeling Service



Algor Education Seminars

## When you visit you can...

- Learn more about FEA, whether you're a novice, or a "guru"
- Download free software - real software, not just demos
- Find the information you need fast with Algor's Magellan Search Commander
- Compare notes with other engineers through Algor's application illustrations
- Try your hand at a variety of verification problems
- Get the latest update and new product information for Algor customers
- Communicate directly with Algor sales, engineering and development people
- Do something new every time you return

E-mail: [info@algor.com](mailto:info@algor.com)

Phone: +1 (412) 967-2700

Fax: +1 (412) 967-2781

For More Information Write In No. 525

# Introducing a new way for workstations to think.



PENTIUM<sup>®</sup>.PRO  
PROCESSOR

It's the Intel Pentium<sup>®</sup> Pro processor. And it's the brains behind some of the most powerful new workstations available.

Whether you're creating 3-D graphics for a hot new Web site or authoring a multimedia title, designing with CAD applications or developing new software,



PENTIUM® PRO  
PROCESSOR

Intel's Pentium Pro processor delivers the  
The Intel Pentium Pro processor. It's the  
stations in a long time. For more information  
<http://www.intel.com/>

performance you need.  
brightest idea to hit work-  
visit our Web site at

**intel**®  
The Computer Inside.™

# CREATE A WALL-SIZED COMPUTER DISPLAY

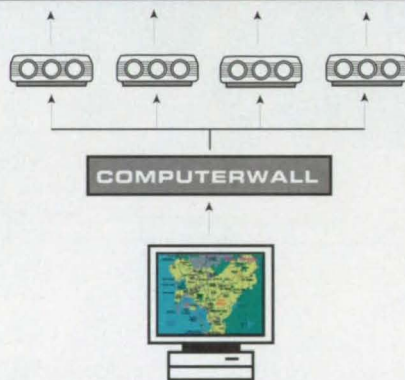

## COMPUTERWALL®

SPLITS COMPUTER IMAGES  
ACROSS MULTIPLE SCREENS FOR  
SIMULATION AND CONTROL  
ROOM APPLICATIONS

- Auto-synch to all computers**
- Inputs up to 1280 x 1024 pixels**
- Compatible with all software**
- Full 24-bit color**



**SPECTRUM®**  
a visual communications company™

950 Marina Village Parkway, Alameda, CA 94501  
Tel: (510) 814-7000 Fax: (510) 814-7026

Published by .....	Associated Business Publications
President/Chief Executive Officer .....	Bill Schnirring
Publisher .....	Joseph T. Pramberger
Senior Editor .....	Linda L. Bell
Editor, Federal Lab Tech Briefs .....	Robert Clark
Production Manager .....	Donna Pituras
Advertising Coordinator .....	Margery Koen
Art Director .....	Lois Erlacher
Production Artist .....	Brian Edgar
Circulation Director .....	Martin J. Horan
Assistant Circulation Director .....	Lori Coppin
Telemarketing Specialist .....	Evelyn Mars
Assistant to Reader Service Manager .....	Damiana Garcia
Sales Support .....	Joanna Lipton

**BRIEFS & SUPPORTING LITERATURE:** Written and produced for NASA by  
**Advanced Testing Technologies, Inc., Commack, NY 11725**

Technical/Managing Editor .....	Ted Selinsky
Sr. Technical Analyst .....	Dr. Larry Grunberger
Art Manager .....	Eric Starstrom
Administrator/Chief Copy Editor .....	Greg Galitzine
Staff Writers/Editors .....	Dr. Theron Cole, George Watson, Howard Falk, Gail Pyke
Graphics .....	Robert Simons
Editorial & Production .....	Joan Schmiemann, Caroline Weaver, Becky D. Bentley

**NASA:**

NASA Tech Briefs are provided by the National Aeronautics and Space Administration, Technology Transfer Division, Washington, DC:	
Administrator .....	Daniel S. Goldin
Director, Commercial Technology .....	Robert Norwood
Deputy Director .....	Carl Ray
Manager, Technology Transfer Office, NASA Center For AeroSpace Information .....	Walter M. Heiland

**ASSOCIATED BUSINESS PUBLICATIONS**

317 Madison Avenue, Suite 921, New York, NY 10017-5391  
(212) 490-3999 FAX (212) 986-7864

President/Chief Executive Officer .....	Bill Schnirring
Executive Vice President/Chief Operating Officer .....	Domenic A. Mucchetti
Treasurer .....	Joseph T. Pramberger
Credit/Collection .....	Felecia Lahey
Staff Accountant .....	Larry Duze
Trade Show Director .....	Wendy S. Corvi
Exhibition Sales .....	Wayne Pierce
Trade Show Coordinator .....	Tracy A. Wenz
Human Resources Manager .....	Lourdes Del Valle
MIS Manager .....	Ted Morawski
Assistant MIS Manager .....	Pak Tong
MIS Data Entry .....	Roxanne Portella
Office Manager .....	Sylvia Valentin
Mailroom Operations .....	Alfredo Vasquez, Thomas C. Snyder, Rose D'Addozio
Administrative Assistant .....	Christine Saluzzi
Receptionist .....	Joanna Lipton

**NASA TECH BRIEFS ADVERTISING ACCOUNT EXECUTIVES**

Headquarters .....	(212) 490-3999
PA, DE, NJ (Area Code 908, 609), VA, DC, MD, WV .....	Tara Morie at (610) 640-3118
Eastern MA, NH, ME, RI .....	Paul Gillespie at (508) 429-8907
Western MA, CT, VT .....	Bill Doucette at (508) 429-9861
Southeast, South Central .....	George Watts at (802) 875-3310
OH, MI, IN, KY, Western NY .....	Robert Hubbard at (910) 299-7754
IL, WI, MO, IA, MN, ND, SD, NE, KS .....	Louise Clemens at (216) 397-7477
N. Calif., CO .....	Melinda Mead at (312) 296-2040
WA, OR, ID, MT, WY .....	Bill Hague at (415) 974-1211
S. Calif., (Area Codes 909, 818, 805, 213, 310), NV, UT .....	Bill Madden; Bill Hague at (206) 858-7575
S. Calif., (Area Codes 619, 714), AZ, NM .....	Tom Stillman at (310) 372-2744
Japan .....	Richard Ayer; Jane Hayward at (714) 366-9089
	Akio Saijo at 03 (5691) 3335

**How To Reach Us On Line**

Letters to the editor: [ntb\\_edit@interramp.com](mailto:ntb_edit@interramp.com)  
To find out about advertising opportunities:  
[ntb\\_advertise@interramp.com](mailto:ntb_advertise@interramp.com)  
NASA Tech Briefs home page: <http://www.keds.com/ntb>



# NASA

launches **Fortran PowerStation** from  
Alabama **desktop**.

No, it isn't science fiction; the folks at NASA really do run compute-intensive programs on their PCs. The secret is new Microsoft® Fortran PowerStation 4.0. It brings UNIX workstation-caliber performance to the desktop without workstation premiums.

Each day, Dr. Stephens (seen below) and his colleagues at the NASA Marshall Space Flight Center download terabytes of data from orbiting satellites. The data is then fed into PCs for analysis, using massive models written in Fortran. This helps them make the cosmos, well, less cosmic. It also helps them make their operating budget less of a black hole.

Since it's built expressly for 32-bit platforms like Microsoft Windows® 95 and Windows NT™ operating systems, Fortran PowerStation 4.0 delivers true multithreading, preemptive multi-tasking, and symmetrical multi-processing. And with language extensions for IBM®, DEC,™ and Cray, migrating legacy code is never a problem.

As you would expect, Fortran PowerStation 4.0, Professional Edition, comes with the Microsoft IMSL® library of nearly 1,000 mainframe-class mathematical and statistical functions. It also comes with the same Microsoft Developer Studio that ships with the Visual C++ development system 4.0. Developer Studio is an integrated development environment that includes an editor, debugger, browser, and profiler, as well as complete online documentation. Which makes building and debugging applications a lot easier even if you're not a rocket scientist.

To learn more about Fortran PowerStation 4.0, visit us at <http://www.microsoft.com/fortran>. To order a free Test Drive CD-ROM, or to locate a reseller near you, call (800) 899-0435, Dept. 66Y.\*

A small **step** for  
mankind



*"Fortran PowerStation 4.0 allows us to downsize. Now we can use lower-cost Intel®-based PCs to solve complex problems that previously required UNIX® workstations or even a Cray® supercomputer."*

Dr. Briscoe Stephens  
Adv. Scientific Systems Coordinator  
Space Science Laboratory  
NASA Marshall Space Flight Center  
Huntsville, Alabama



*Hosts/targets  
Windows 95  
& Windows NT  
Workstation*



*32-bit compiler  
& linker with  
4 GB addressable  
memory*



*Language  
extensions for  
easy code  
migration*



*Interoperable  
with Microsoft  
Visual C++™ 4.0 and  
Visual Basic® 4.0*



*Full support  
for Fortran 90*

\*Only in the 50 United States and Canada. Test Drive CD-ROM offer expires 4/31/96. Allow 2-4 weeks for delivery. ©1995 Microsoft Corporation. All rights reserved. Microsoft, Visual Basic, and Windows are registered trademarks and Visual C++, Where do you want to go today?, and Windows NT are trademarks of Microsoft Corporation. Cray is a registered trademark of Cray Research Inc. DEC is a trademark of Digital Equipment Corporation. IBM is a registered trademark of International Business Machines Corporation. IMSL is a registered trademark of Visual Numerics, Inc. Intel and Pentium are registered trademarks of Intel Corp. UNIX is a registered trademark in the U.S. and other countries, licensed exclusively through X/Open Company, Ltd.

## Microsoft®

WHERE DO YOU WANT TO GO TODAY?™

For More Information Write In No. 502

## NASA Commercial Technology Team

NASA's R&D efforts produce a robust supply of promising technologies with applications in many industries. A key mechanism in identifying commercial applications for this technology is NASA's national network of commercial technology organizations. The network includes ten NASA field centers, six Regional Technology Transfer Centers (RTTCs), the National Technology Transfer Center (NTTC), business support organizations, and a full tie-in with the Federal Laboratory Consortium (FLC). We encourage all businesses with technical needs to contact the appropriate organizations for more information. NASA's Commercial Technology Network now provides information services on the World Wide Web. For the purposes of readability and organization, NASA has chosen to use some "extended Web form" commands. To reach the network the way it is intended to appear, you will need to use a "forms-compatible browser." There are several such browser tools commercially available. Information on one such tool, Netscape, can be obtained by sending an E-mail request to [info@netscape.com](mailto:info@netscape.com) or by calling 415-528-2555. (It is not the intent of this message to influence anyone's choice of an Internet browser. Other browsers are available.) The URL for the NASA Commercial Technology Home Page is <http://nctn.hq.nasa.gov>.

## NASA's Technology Sources

If you need further information about new technologies presented in *NASA Tech Briefs*, request the Technical Support Package (TSP) indicated at the end of the brief. If a TSP is not available, the Commercial Technology Office at the NASA field center that sponsored the research can provide you with additional information and, if applicable, refer you to the innovator(s). These centers are the source of all NASA-developed technology.

### Ames Research Center

Selected technological strengths: Fluid Dynamics; Life Sciences; Earth and Atmospheric Sciences; Information, Communications, and Intelligent Systems; Human Factors.  
*Syed Shariq*  
(415) 604-0753  
[syed\\_shariq@qm.gate.arc.nasa.gov](mailto:syed_shariq@qm.gate.arc.nasa.gov)

### Dryden Flight Research Center

Selected technological strengths: Aerodynamics; Aeronautics; Flight Testing; Aeropropulsion; Flight Systems; Thermal Testing; Integrated Systems Test and Validation.  
*Lee Duke*  
(805) 258-3119  
[duke@louie.dfrf.nasa.gov](mailto:duke@louie.dfrf.nasa.gov)

### Goddard Space Flight Center

Selected technological strengths: Earth and Planetary Science Missions; LIDAR; Cryogenic Systems; Tracking; Telemetry; Command.  
*George Alcorn*  
(301) 286-5810  
[galcorn@gsgf-mail.nasa.gov](mailto:galcorn@gsgf-mail.nasa.gov)

### Jet Propulsion Laboratory

Selected technological strengths: Near/Deep-Space Mission Engineering; Microspacecraft; Space Communications; Information Systems; Remote Sensing; Robotics.  
*Wayne Schober*  
(818) 354-2240  
[wayne.r.schober@jpl.nasa.gov](mailto:wayne.r.schober@jpl.nasa.gov)

### Johnson Space Center

Selected technological strengths: Artificial Intelligence and Human Computer Interface; Life Sciences; Human Space Flight Operations; Avionics; Sensors; Communications.  
*Hank Davis*  
(713) 483-0474  
[hdavis@gp101.jsc.nasa.gov](mailto:hdavis@gp101.jsc.nasa.gov)

### Kennedy Space Center

Selected technological strengths: Emissions and Contamination Monitoring; Sensors; Corrosion Protection; Bio-Sciences.  
*Bill Sheehan*  
(407) 867-2544  
[billsheehan@ksc.nasa.gov](mailto:billsheehan@ksc.nasa.gov)

### Langley Research Center

Selected technological strengths: Aerodynamics; Flight Systems; Materials; Structures; Sensors; Measurements; Information Sciences.  
*Charlie Blankenship*  
(804) 864-6005  
[c.p.blankenship@larc.nasa.gov](mailto:c.p.blankenship@larc.nasa.gov)

### Lewis Research Center

Selected technological strengths: Aeropropulsion; Communications; Energy Technology; High Temperature Materials Research.  
*Walter Kim*  
(216) 433-3742  
[wskim@lirms01.lerc.nasa.gov](mailto:wskim@lirms01.lerc.nasa.gov)

### Marshall Space Flight Center

Selected technological strengths: Materials; Manufacturing; Nondestructive Evaluation; Biotechnology; Space Propulsion; Controls and Dynamics; Structures; Microgravity Processing.  
*Harry Craft*  
(800) USA-NASA  
*Susan Van Ark*  
[susan.van.ark@msfc.nasa.gov](mailto:susan.van.ark@msfc.nasa.gov)

### Stennis Space Center

Selected technological strengths: Propulsion Systems; Test/Monitoring; Remote Sensing; Nonintrusive Instrumentation.  
*Anne Johnson*  
(601) 688-3757  
[ajohnson@ssc.nasa.gov](mailto:ajohnson@ssc.nasa.gov)

## NASA Program Offices

At NASA Headquarters there are seven major program offices that develop and oversee technology projects of potential interest to industry. The street address for these strategic business units is: NASA Headquarters, 300 E St. SW, Washington, DC 20546.

*Gene Pawlik*  
**Small Business Innovation Research Program (SBIR)**  
(202) 358-4661  
[gpawlik@oact.hq.nasa.gov](mailto:gpawlik@oact.hq.nasa.gov)

*Bill Smith*  
**Office of Space Sciences (Code S)**  
(202) 358-2473  
[wsmith@sm.ms.ossa.hq.nasa.gov](mailto:wsmith@sm.ms.ossa.hq.nasa.gov)

*Robert Norwood*  
**Office of Space Access and Technology (Code X)**  
(202) 358-2320  
[rnorwood@oact.hq.nasa.gov](mailto:rnorwood@oact.hq.nasa.gov)

*Bert Hansen*  
**Office of Microgravity Science Applications (Code U)**  
(202) 358-1958  
[bhansen@gm.olmsa.hq.nasa.gov](mailto:bhansen@gm.olmsa.hq.nasa.gov)

*Philip Hodge*  
**Office of Space Flight (Code M)**  
(202) 358-1417  
[phodge@osfms1.hq.nasa.gov](mailto:phodge@osfms1.hq.nasa.gov)

*Granville Paules*  
**Office of Mission to Planet Earth (Code Y)**  
(202) 358-0706  
[gpaules@mtpe.hq.nasa.gov](mailto:gpaules@mtpe.hq.nasa.gov)

*Gerald Johnson*  
**Office of Aeronautics (Code R)**  
(202) 358-4711  
[g\\_johnson@aeromail.hq.nasa.gov](mailto:g_johnson@aeromail.hq.nasa.gov)

## NASA's Business Facilitators

NASA has established several organizations whose objectives are to establish joint sponsored research agreements and incubate small start-up companies with significant business promise.

*Lee Rivers*  
**National Technology Transfer Center**  
(800) 678-6882

*Dr. William Gasko*  
**Center for Technology Commercialization**  
(800) 472-6785 or  
(508) 870-0042

*Gary Sera*  
**Mid-Continent Technology Transfer Center**  
Texas A&M University  
(800) 472-6785 or  
(409) 845-8762

*Chris Coburn*  
**Great Lakes Industrial Technology Center**  
Battelle Memorial Institute  
(800) 472-6785 or  
(216) 734-0094

*Dr. Richard Johnson*  
**American Technology Initiative**  
Menlo Park, CA  
(415) 325-5353

*John Gee*  
**Ames Technology Commercialization Center**  
Sunnyvale, CA  
(408) 734-4700

*Robert Stark*  
**Far-West Technology Transfer Center**  
University of Southern California  
(800) 642-2872 or  
(213) 743-2353

*J. Ronald Thornton*  
**Southern Technology Applications Center**  
University of Florida  
(800) 472-6785 or  
(904) 462-3913

*Lani S. Hummel*  
**Mid-Atlantic Technology Applications Center**  
University of Pittsburgh  
(800) 472-6785 or  
(412) 648-7000

*Jill Fabricant*  
**Johnson Technology Commercialization Center**  
Houston, TX  
(713) 335-1200

*Dan Morrison*  
**Mississippi Enterprise for Technology**  
Stennis Space Center, MS  
(800) 746-4699

**Easy Access To The FLC:** Call (206) 683-1005 for the name of the Federal Laboratory Consortium Regional Coordinator in your area. The Regional Coordinator, working with the FLC Locator, can help you locate a specific laboratory to respond to your needs.

If you are interested in information, applications, and services relating to satellite and aerial data for Earth resources, contact: Dr. Stan Morain, **Earth Analysis Center**, (505) 277-3622. For software developed with NASA funding, contact **NASA's Computer Software Management and Information Center (COSMIC)** at (706) 542-3265, fax (706) 542-4807. If you have a questions...**NASA's Center for AeroSpace Information** can answer questions about NASA's Commercial Technology Network and its services and documents. Use the Feedback Card in this issue or call (410) 859-5300, ext. 245.



# PCI-EZ™ is the standard—others will follow.

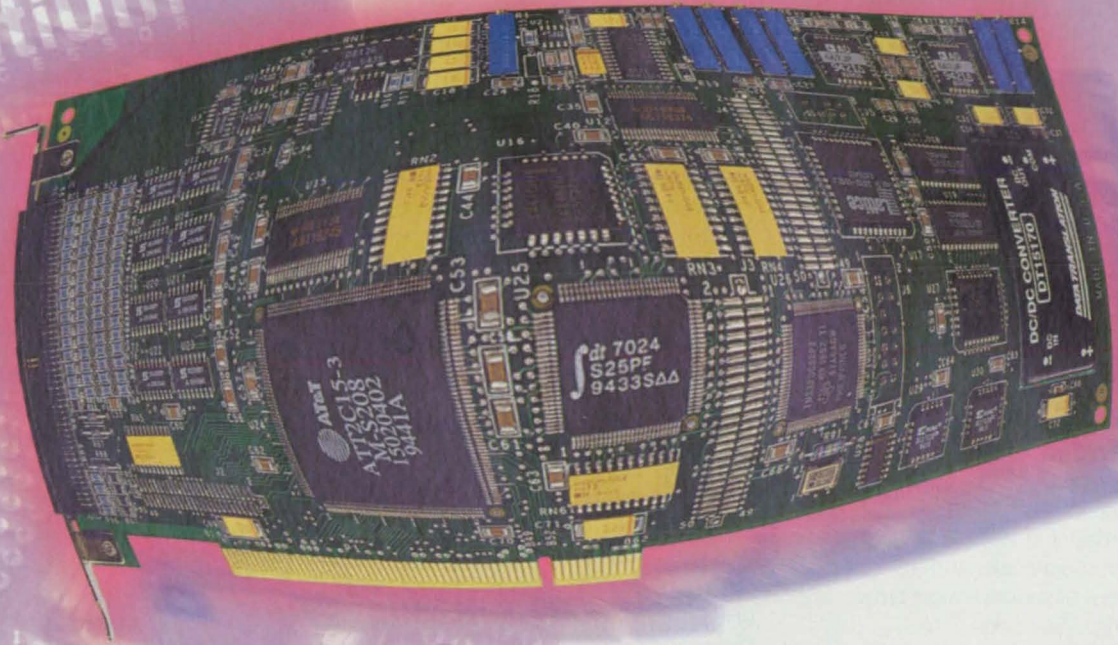

## Packed with performance, it's the first PCI data acquisition board for your Pentium™

### The rest must follow the leader.

PCI-EZ is a cutting-edge series of low-cost, multi-function, data acquisition boards for the PCI Bus within your PC. You'll clearly see the difference in performance.

### Filled with benefits.

One of the greatest advantages to the PCI Bus is that it operates at a higher priority than other peripheral buses, giving PCI-compatible boards first shot at system resources like RAM, the hard disk, and the CPU. Also,

PCI's higher bandwidth allows all subsystems on a board to operate simultaneously, resulting in speeds up to 15 times that of the ISA Bus. In addition, PCI devices can access memory without involving the CPU, letting you run other applications or perform data processing concurrent with PCI data acquisition. All of these benefits, combined with PCI's support of true Plug 'N Play, gives you a leading advantage to develop first-rate test and measurement applications.

Standards following standards:  
PCI-EZ supports DT-Open Layers.

DT-Open Layers is a set of open standards for developing integrated, modular software under Microsoft Windows. Not only does it allow access to our hardware at the touch of a button, but it ensures support of all hardware upgrades and new functions for the future — including those on standard PC buses like PCI, ISA and PCMCIA. That's why we call DT-Open Layers the insurance policy that comes with every Data Translation purchase.

Model	Channels	Analog Inputs		Analog Outputs		Digital I/O Lines	
		Resolution (bits)	Gain	Throughput (kHz)	Throughput (kHz)		
DT3001	16SE/8DI	12	1, 2, 4, 8	330	2 DACs	200/DAC	8
DT3002	32SE/16DI	12	1, 2, 4, 8	330	—	—	8
DT3003	64SE/32DI	12	1, 2, 4, 8	330	2 DACs	200/DAC	8
New	16SE/8DI	16	1, 2, 4, 8	100	2 DACs	200/DAC	8

So call us today, and discover for yourself why the competition follows our standards.

# 1-800-525-8528

INTERNET: <http://www.datx.com>



World Headquarters: (508) 481-3700, UK Headquarters: (01734) 793838, Germany Headquarters: (07142) 95 31-0, Italy Headquarters: (030) 2425696.

Sales Offices: Argentina 322-3791; Australia (02) 9979 5643; Austria 13697660; Belgium 02-5 69 56 47; Brazil (011)564-6024; Canada (508) 481-3700, (416) 625-1907; Chile 638 7806; China 8428276, 10 833 1145; Denmark 48 14 14 88; Finland (90) 351 1800; France (1) 69 07 92 12; Greece (301)3846200; Hong Kong 2515-0018; India (22) 2831040; Israel 9-581860; Japan (03) 5489-3871; Korea (02) 718-9521; Malaysia (03) 261 6786; Mexico (5) 575-6091; The Netherlands 010-47 95 700; New Zealand 94158362; Norway 2243 4150; Portugal 01/793 48 34; Singapore 773 4300; South Africa 12803 7680; Spain 91-555.8112; Sweden 08-765 02 80; Switzerland 01/908 13 13; Taiwan (02) 561-2211; Thailand (02) 668-5080; Turkey (21) 288 6213 10/10/95

For More Information Write In No. 530



## New Product Ideas

New Product Ideas are just a few of the many innovations described in this issue of *NASA Tech Briefs* and having promising commercial applications. Each is discussed further on the referenced page

in the appropriate section in this issue. If you are interested in developing a product from these or other NASA innovations, you can receive further technical information by requesting

the TSP referenced at the end of the full-length article or by writing the Commercial Technology Office of the sponsoring NASA center (see page 14).

### Advanced Triangulation Displacement Sensors

In comparison with other optoelectronic sensors, these are highly miniaturized, more stable, more accurate, and relatively easy to use. In principle, these sensors could be mass produced at a relatively low unit cost. (See page 28.)

### CMOS Active-Pixel Image Sensor With Intensity-Driven Readout

A proposed sensor would automatically generate readouts from pixels of decreasing illumination intensity. Its unique function would be useful in diffractive laser range finding, three-dimensional imaging, event-drive readout of sparse sensor arrays, and star tracking. (See page 29.)

### Lightweight Cathodes for Nickel Batteries

Fibrous cathode mats currently under development accommodate more charge per unit mass than sintered nickel plaque cathodes. Nickel/hydrogen cells made with the fibrous cathodes exhibit specific energy of 90 W-h/kg, as opposed to 50 W-h/kg from the sintered cathodes. (See page 35.)

### Measuring Motor-Shaft Clearance and Wobble During Operation

A system produces an early warning of oncoming bearing failure and also prevents unnecessary replacements. The bearings can be replaced on an as-needed basis, without catastrophic failures or costly premature scheduled maintenance. (See page 50.)

### Mechanism Attaches to Special Fixture

A new mechanism grasps a striker bar with hooks, pulling itself inward so that its pads press against a structural member. Such a mechanism may be useful for temporary attachment of various items to structures or machines. (See page 72.)

### Rod Has High Tensile Strength and Low Thermal Expansion

A thoriated tungsten extension rod replaces a stainless-steel extension rod that had been attached to a linear variable-differential transformer in a gap-measuring gauge. The new rod is better in applications encountered in measuring gaps in rocket motors. (See page 73.)

Choosing math software is easy – compare **Macsyma** with the runners up.

<b>New</b> Macsyma 2.1 for Windows 95	<b>Macsyma 2.0.8</b>	<b>Maple V.3</b>	<b>Math'a 2.2.3</b>
Score on largest test of math software*	108	90.5	88
<b>Ease of Use / On-Line Help</b>			
Execute demos from menus	yes (800)	no	no
Fill-in templates	yes (500)	no	no
Autoloading	yes	no	no
<b>Formatted Math Display</b>	yes	no	no
<b>Edit Graphics in Notebooks (Hyper)Text Processing</b>	yes	no	no
Format letters, paragraphs	yes	no	no
User-defined hypertext	yes	no	no
<b>Price</b>	low	mid	high

\* Wester, M., *Computer Algebra Netherlands*, Dec. 1994. Or see ftp.math.unm.edu/pub/cas/Paper.ps . Scores of ±1, 0 mean correct / incorrect and no answer.

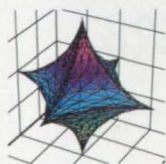

"Macsyma is now the leader in the math program marketplace." - PC Magazine

"Macsyma is the heavy artillery ... remarkably easy to use." - IEEE Spectrum

"No other math software has such satisfying on-line help" - MC Extra (Germany)

Solving engineering problems with finite elements was never so easy!

### **New** PDEase 2.5 with eigenanalysis

- **Flexible...**
  - Single equations or systems
  - (Non)linear, static/dynamic and eigenvalue problems
  - Many boundary conditions
- **Easy to use...**
  - Simple input language
  - Smart adaptive grid generator
  - 90 executable demonstrations
- **Powerful...**
  - Tens of thousands of nodes
  - Model solids, fluids, diffusion, reactions, waves and electro-magnetics together.
  - Uniquely adaptable to cross-disciplinary problems.
- **Affordable**

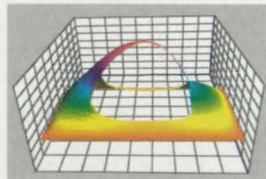

• "PDEase is a breakthrough on two counts: flexibility and cost." - IEEE Spectrum

• "PDEase is a unique program in a class by itself ... an unbeatable deal." - Design News

• "... After a few hours of exercises, the arsenal of finite elements is at your fingertips." - Computers in Physics

Call 800-macsyma for a free demo disk or workstation trial today.



Macsyma Inc.  
20 Academy Street  
Arlington, MA 02174

info@macsyma.com  
http://www.macsyma.com

800-622-7962  
tel: 617-646-4550  
fax: 617-646-3161



PDEase is a registered trademark of SPDE, Inc.

What does technology transfer mean to the U.S. manufacturer struggling to compete in a changing global marketplace?



By Lee W. Rivers, Executive Director  
National Technology Transfer Center

As a result of the efforts of the National Technology Transfer Center (NTTC), it means taking advantage of world class resources made possible by the federal government and available for use in efforts to improve manufacturing processes.

Those resources take the form of 700 federal laboratories where 100,000 researchers utilize \$25 billion worth of R&D investment every year. Other resources result from an annual \$11 billion federal investment in university research. The purpose of the NTTC is to enhance the competitiveness of American industry in the global marketplace.

The *free* gateway service is accessed by calling (800) 678-6882. U.S. companies can gain quick and accurate access to the wealth of information resident in the federal laboratory system.

The NTTC's gateway system consists of a team of technology access agents with specialties ranging from nuclear science to electrical engineering. Each caller's request is

handled individually by a technology access agent who: identifies the specific needs of the caller; uses the Center's information resources and alliances to locate current and completed research; and provides laboratory contacts which the caller may use to secure answers to technical questions, explore licensing opportunities and pursue Cooperative Research and Development Agreements (CRADA).

The NTTC's technology access gateway operation has handled more than 10,000 requests since it opened in October 1992. Most gateway successes to date have been in the area of technical assistance.

However, some commercial successes and significant collaborations have been reported. For example:

**E.A. Fischione Instruments, Inc., Export, PA.** Fischione called the gateway in November 1992 to ask for help in developing an ion mill for thinning microscope specimens. The NTTC technology agent referred the company to the Lawrence Berkeley Laboratory. In six months of nearly weekly telephone discussions with an LBL specialist in ion technology and argon plasma, the company was guided through crucial stages of product development.

"It was real, fundamental R&D support," said Bob Spelic, Fischione's VP for Engineering. "The product that came out of this investigation should double our sales..."

In addition to the gateway, the NTTC offers an electronic bulletin board system, *Business Gold*. This system is an easy, convenient way to access the latest information on the newest technologies available through the R&D programs at the federal laboratories.

On an average, 25,000 people

log-on to *Business Gold* a month. This includes those looking for licensing opportunities, searching federal databases or seeking information about a particular federal laboratory.

*Business Gold* can be accessed through the World Wide Web @ <http://www.nttc.edu>. Information available includes:

- Current SBIR, STTR, & TRP solicitations
- State technical assistance programs
- New technologies available for licensing
- Searchable databases

Only a portion of federal research can be made available on a public access bulletin board. The NTTC technology agents have access to many additional databases. If you cannot find what you need on-line, contact our gateway service at (800)678-6882.

Training programs are provided by the NTTC to government laboratory personnel that give assistance in identifying technologies ready for commercialization and attracting industry to interest in their technologies.

The NTTC is also providing training to industrial extension agents to foster the sharing and application of best practices and enhance and improve the interpersonal and critical thinking skills of the agents.

Meanwhile, our economic development efforts help improve U.S. technology transfer by recognizing and disseminating best practices, assisting in the development of strategic partnerships, and addressing state and local issues.

For more information call:



National Technology Transfer Center  
Wheeling Jesuit College  
316 Washington Avenue  
Wheeling, WV 26003

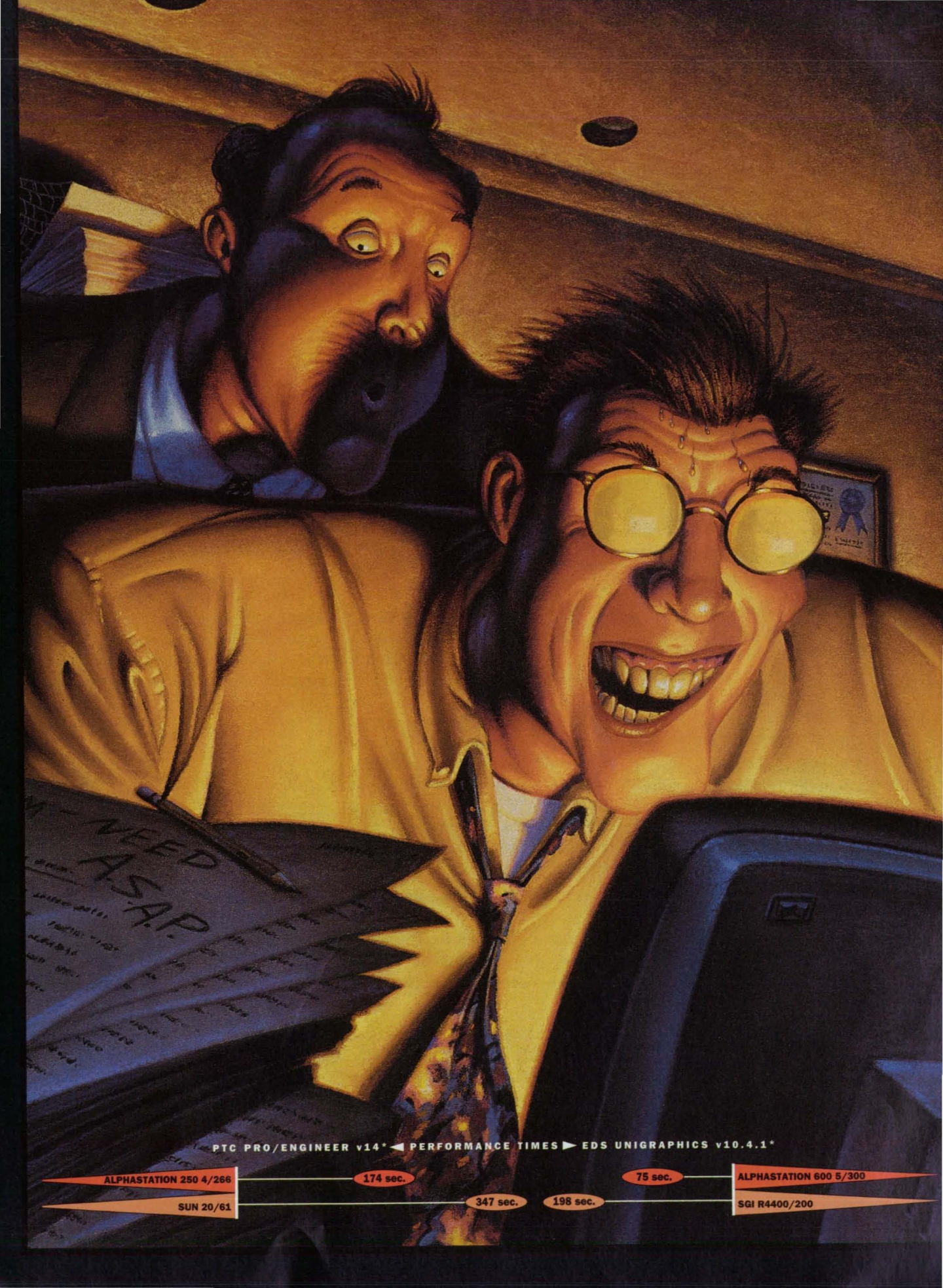

PTC PRO/ENGINEER v14\* ◀ PERFORMANCE TIMES ▶ EDS UNIGRAPHICS v10.4.1\*

ALPHASTATION 250 4/266

174 sec.

75 sec.

ALPHASTATION 600 5/300

SUN 20/61

347 sec.

198 sec.

SGI R4400/200

**ENJOY INDUSTRY-LEADING PRICE/PERFORMANCE FROM PRO/ENGINEER, CADDs 5, UNIGRAPHICS...**

*Astounding visualizations. Unprecedented speed. Unlimited collaboration. Though*

**IN ENGINEERING** *they may quibble*  
**TERMS: MAKE** *over terms, MCAD*  
**COOLER** *veterans would agree that the*  
**STUFF HAPPEN** *AlphaStation™ family is a leap beyond 32-bit workstations. From our*  
**WAY FASTER.** *entry-level machine to our*  
*fastest-in-the-universe*  
*AlphaStation 600 system, these 64-bit*

*demons deliver superior performance from a host of MCAD applications—*  
*and unbeatable price/performance as well. AlphaStation systems offer superb*  
*networking capabilities, too. So team members can share files in “white board”*  
*fashion, even at remote locations. Of course, the coolest thing about all this is*  
*that you’ll do more iterations in less time, so you’ll get to market sooner and*

**THE ALPHASTATION FAMILY.**  
**WARP-SPEED MCAD.**

*leave your competitors with a face full of dust.*

*(Technically speaking.) To learn more cool stuff about the*

*AlphaStation family, and our powerful, fully compatible*

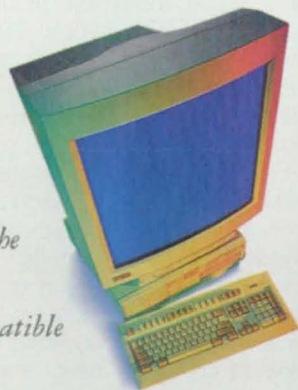

**digital™**

*AlphaServer™ systems, call one*

*The AlphaStation 250 System*

*of our Business Partners, or phone 1-800-DIGITAL, press 4, for specs. And check*  
*out our Web site, <http://www.digital.com>, or send e-mail to [moreinfo@digital.com](mailto:moreinfo@digital.com).*

©1995 Digital Equipment Corporation. Digital, the DIGITAL logo, AlphaStation and AlphaServer are trademarks of Digital Equipment Corp. All other products are trademarks or registered trademarks of their respective companies. \*Based on Digital's latest internal testing. Timings are geometric means of several tests. Details available upon request.

# Technology 2005 Roundup

More than 6000 industry and government leaders gathered in McCormick Place to share America's best new design and engineering ideas.



**NASA Administrator Daniel Goldin emphasized the agency's role as an information systems organization in his keynote address to Technology 2005 attendees.**

**T**echnology 2005 swept into Chicago October 24-26, showcasing the latest products and technologies from NASA, the military, other federal agencies, and commercial industry. NASA Administrator Daniel S. Goldin officially opened the sixth annual national technology transfer conference and exposition with his keynote address.

Goldin's address focused on the importance of American space exploration ten to 30 years from now, and how NASA is positioning itself as a long-term organization. "NASA is about the future," said Goldin. "It's about going to the cutting edge and doing things you'd never even dream about. We want to open up the space frontier, and when we do, we need to share the riches or NASA hasn't earned its way."

Goldin said that although NASA's budget is decreasing, its productivity has increased. "People judge the vitality of a program by how fast its budget is growing," he stated. "I don't want to measure input. I want to measure output."

The address emphasized NASA's role as an information systems organization,

as well as the commercial implications of the \$120 million spent annually by NASA on the Small Business Innovation Research (SBIR) program. "People think of NASA in terms of belching rockets, but we're about information systems, biotech, and biomed. Every time we do something, it leads to another discovery," said Goldin. "It's crucial that NASA connect with industry to develop long-range products that we can use for the space program. There is a necessity and an obligation for us to take the technology we have and transfer it to you to make dual-use products." That way, Goldin explained, "we benefit, you benefit, and the American people benefit."

## Digital Doctoring

Wednesday's plenary session, "Communications 2005: The Future is Digital," featured a demonstration of a telemedicine system introduced by NASA, the University of Texas Health Science Center at San Antonio (UTHSCSA), VTEL, and Sprint. Dr. James D. Legler, an associate professor in UTHSCSA's Department of Family Medicine, conducted a live consultation with a physician at South Texas Hospital (STH) and her young leukemia patient.

The project is designed to serve indigent Hispanic children with cancer living in the medically underserved areas of South Texas near the Mexican border who have no consistent access to pediatric oncology specialists. Telemedicine provides direct visual examination by specialists, including examination of x-rays and blood smear samples, and bone marrow aspiration slides.

The network system in Texas consists of two VTEL 227M video teleconferencing units—one located within UTHSCSA's Department of Pediatrics and the other in the outpatient clinic at STH. The machines are connected via a T-1 communications linkage. The system incorporates two auxiliary inputs: a document camera for transmitting x-ray images, and

a microscope camera that permits transmission of bone marrow biopsy slides.

Currently, there are 50 to 100 telemedicine systems installed in the US. Future plans are to establish a site in Monterrey, Mexico, and to conduct consultations via a VTEL desktop-based system.

(For more information, contact Dr. James Legler; Tel: 210-270-3911; E-mail: legler@uthscsa.edu)

## Small Business Stars

Five companies took home 1995 Small Business Innovation Research (SBIR) Technology of the Year Awards; established by Associated Business Publications and the Technology Utilization Foundation to recognize important new technologies with strong commercial potential developed through the government's SBIR grant program. Awards were presented at the 1995 Technology Transfer Awards Dinner held in conjunction with Technology 2005.

The 1995 Grand Award went to Martek Biosciences Corp. of Columbia, MD (410-740-0081), for an infant formula supplement called Formulaid, developed under a National Institutes of Health SBIR. Martek identified microorganisms that produce oils rich in two single-cell long-chain polyunsaturated fatty acids believed by many researchers to be critical to infant mental and visual development. When added to formula, Formulaid provides these essential fatty acids in the natural triglyceride form, matching the composition of breast milk without any of the drawbacks of other sources such as fish oils and egg yolks.

Five companies, including Wyeth-Ayerst, the Mead Johnson Division of Bristol-Myers Squibb, and Maarbarot Products Ltd. of Israel, have licensed use of the supplement for their infant formulas, and Nutricia launched a preterm formula containing it last year. Martek is currently studying ways of processing the oils for over-the-counter sales as a dietary supplement.

Awards were presented in four technology categories. The winner in the Environment, Energy & Resource Management category was PDA Inc. of Midlothian, VA (804-744-0604), whose work was supported by a US Army grant. Its patented electrically enhanced filtration (EEF) maintains the filtering medium



**Dr. Javier R. Kane (left) of the University of Texas Health Science Center at San Antonio confers with nurse Tracy Meyers at South Texas Hospital via a telemedicine system demonstrated at Technology 2005. Registered nurse John Drake assists in the consultation.**

within an ionizing field, resulting in extremely high biocidal effects on *E coli* and other bacteria. Unlike electrostatically enhanced methods, EEF combines extremely high filtration efficiency with low flow resistance and is not subject to spark discharge toward the filter. It will find primary applications in high-performance cleanrooms; residential, commercial, and hospital heating, ventilation, and air conditioning; industries such as printing and paint booths; and clean manufacturing zones, especially for biotech/medical systems. Enabling up to two orders of magnitude higher performance at a cost comparable with conventional technology, it is expected to have a quick impact in the cleanroom, HVAC, and military markets.

In the Industrial/Manufacturing category, the winner was Silicon Mountain Design Inc. of Colorado Springs, CO (719-599-7700). With the help of an Army Research Laboratory award, the company developed a high-speed CCD camera to analyze flight dynamics of missiles and kinetic weapons. Making use of a multiport parallel-output architecture, the system enables instant playback and real-time adjustment of focus and light level. Demonstration of the Phase II prototype led to commercial development with Teledyne Brown Engineering to adapt it to machine vision applications. SMD also is working with Thomson of France to apply the camera to cardiac catheterization and angiography.

The award in the Computers/Electronics category went to Thermacore Inc., Lancaster, PA (717-569-6551), whose Thermal Products Operation produces high-performance heat pipes to cool Pentium chips in notebook computers. The technology and the ability to predict device performance stem from a series of SBIR contracts with NASA, the Air Force, and the Army. These heat pipes transfer

heat by means of a condensate, which returns to the evaporator through a powder metal wick, so the user of a notebook computer can operate it in any position without loss of performance. Production rates of these cost-competitive devices were expected to pass 5000 per day by the end of 1995.

Taking home the prize in the Health/Medicine category was Transcience Associates Inc. of Evanston, IL (708-475-1125). Developed with a grant from the National Institutes of Health, the MicroFlo™ rubber-gear pump serves as the heart of a 3-axis robotic pipettor/dispenser system that can load microliter volumes into multiwell immunoassay microplates. The invention eliminates the slow and fatiguing manual loading of cavities in the standard 96-microwell immunoassay plate in universal use.

*(For information on the SBIR Technology of the Year Awards competition, contact Wayne Pierce at the Technology Utilization Foundation; Tel: 212-490-3999; Fax: 212-986-7864.)*

### **Transportation Tomorrow**

A focal point of the Technology 2005 exhibits hall was the Transportation Tomorrow pavilion, which featured cutting-edge automotive, marine, mass transport, and aviation vehicles, and advanced engine/propulsion systems.

Among the vehicles on display were the Patriot hybrid electric race car (see *NASA Tech Briefs*, June 1995, pg. 12) from Chrysler (810-576-8095); the SuperNatural® Corvette

LeMans, a 500+ horsepower race car with carbon-carbon engine parts from Callaway (860-434-9002); and Buick's XP2000 concept car featuring voice-activated satellite navigation, and docking ports to plug in personal computers (517-546-5524).

The CarterCopter, a craft combining the vertical take-off and landing capabilities of helicopters with the speed efficiency and altitude capabilities of fixed-wing aircraft, was unveiled by CarterCopters of Wichita Falls, TX (817-691-0819). When completed, the copter will be able to carry five people, take off vertically, cruise nonstop coast-to-coast at over 300 mph, and land vertically without the need for a normal runway. James Dunn, co-executive director of NASA's Center for Technology Commercialization, predicted that the new design "could revive the general aviation market."

Orbital Engine Company Inc. of Tecumseh, MI (517-423-6623) exhibited the Orbital Combustion Process (OCP) engine technology which has been licensed to Ford, General Motors, and Fiat, and to marine engine manufacturers including Mercury Marine and Outboard Marine Corp. The 50% lighter engine reduces emissions and improves fuel consumption by 30% (depending on emissions requirements) while retaining the packaging, weight, and power advantages of the two-stroke engine operating principle.

### **Laser-Based 3D Display**

The RDT&E Division of the Naval Command, Control and Ocean Surveillance Center in San Diego, CA, presented a second-generation 3D volumetric



**Federal Laboratory Consortium Chair Tina McKinley presents the SBIR Technology of the Year Award Grand Winner plaque to Claus Becker of Martek Biosciences Corp. at the Technology Transfer Awards Dinner held in conjunction with Technology 2005.**

# THE WORLD'S SMALLEST SIX-AXIS FORCE/ TORQUE SENSOR

Our new NANO F/T:

- **measures six axes** (Fx, Fy, Fz, Tx, Ty, Tz) of force and torque.
- **is ultra-small**...17mm diameter x 14.5 mm height.
- **is extra-strong**...up to 3000% overload protection.
- **is very quiet**...silicon gages provide high noise immunity.
- **speaks your language**...our intelligent controller outputs data in RS-232, parallel and analog formats.



**F/T**  **Force  
Torque**  
**SENSOR SYSTEM**

Call today to discuss your application with our engineers.



Assurance Technologies, Inc.

503D Highway 70 East • Garner, NC 27529  
Phone: 919-772-0115  
Fax: 919-772-8259

display that enables several observers to view data, information, and scenes in a 3D volume of image space from any position with the naked eye. The device provides, in real time, an actual physical volume of images having height, depth, and width.

Incorporating a 36" diameter double helix that spins at approximately 10 revolutions per second, the device provides a means to address a cylindrical volume. Under computer control, a laser beam is directed to illuminate certain discrete volume points (voxels) on the helix needed to create a scene. The laser light scatters from the surface of the helix, so, to the observer, each voxel appears to emanate from specific points in space.

Potential applications for 3D volumetric display technology include air traffic

(NASA 60%, Rockwell 40%) to develop and demonstrate a durable, lightweight thermal protection system (TPS). A key provision of the new policy set forth in NASA's Access to Space study of 1993 was that, where core technologies were concerned, operations must be a design driver and not merely a goal. Thus, the focus of the TPS program is to reduce the operational costs of reusable vehicles.

Quilted flexible blankets, once under consideration as thermal protection for the RLV, are used on the space shuttle orbiter, but they are unsuitable for the lower surfaces of the launch vehicle, where temperatures are highest and maximum smoothness is required. The leading candidate today is TABI (Tailorable Advanced Blanket Insulation), an integrally woven, fluted core

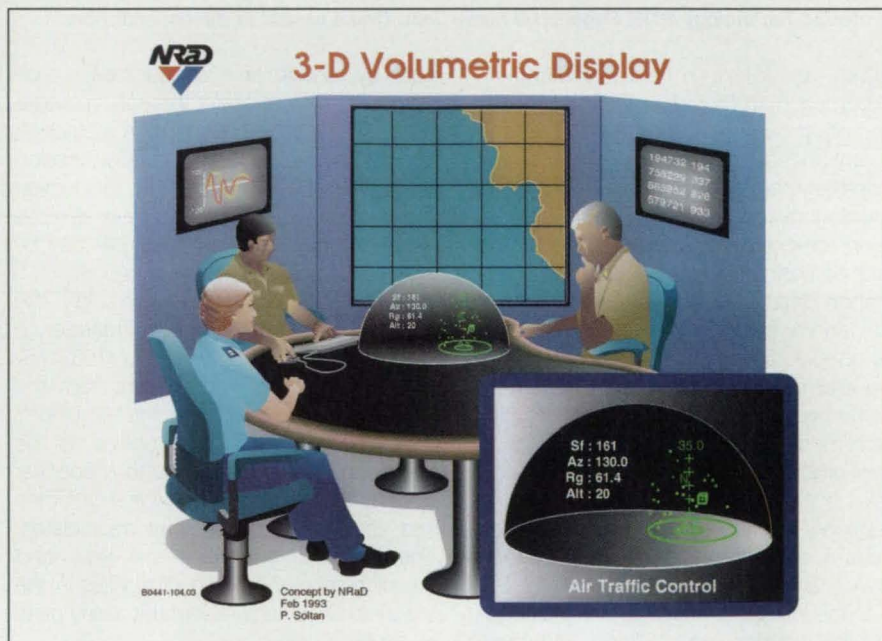

**One potential application of the Navy's laser-based 3D volumetric display system is control and management of air traffic in a volume of aerospace for the FAA, Air Force, or Navy.**

control, military battle management, medical imaging, and 3D television, which would allow viewers to watch from all sides, without special 3D glasses.

(For more information, contact Parviz Soltan at NCCOSC Research & Development; Tel: 619-553-3584.)

## A New Kind of Cooperation

In a session titled "Tech Transfer Success Stories: Profit from Experience," Carol W. Carroll of NASA Ames Research Center described "A New Way of Doing Business: NASA Ames-Rockwell Partnership to Develop Reusable Launch Vehicle Thermal Protection Systems." The partners are united by the aims of making production of reusable launch vehicles (RLVs) viable commercially, reducing government spending, and improving government-industry teaming. In 1994, they entered into a cost-sharing arrangement

structure made of high-temperature ceramic fiber filled with fibrous ceramic insulation to form a flexible blanket. Invented at NASA Ames in the 1980s, it was transferred to Rockwell and currently is baselined on the X-33 Advanced Technology Development Demonstrator Vehicle slated for launch before the end of the decade. The blankets have been subjected to numerous test environments, and the results to date have been encouraging. The partners are taking a similar approach to the issues of waterproofing and TPS integrated health management. Altogether the project is an example of cooperative R&D in action: government performing the fundamental science and basic research tasks, coupled with industry focusing on application and operations issues.

(For more information, contact Carol W. Carroll of NASA Ames Research Center; Tel: 415-604-0267.)



## If You Missed These Exhibitors at Technology 2005

Write in their numbers on the Information Request Form (preceding page 65) for details on their products and services.

Aeromobile, Inc. ....	800	Imi-Tech Corp. ....	834	Rockwell Space Systems Division .....	872
Aerospatiale .....	801	Information Development, Inc. ....	836	Sonoscan Inc. ....	873
Air Force Phillips Laboratory .....	802	Ingenieurschule Biel .....	837	Sophia Systems and Technology .....	874
American Heuristics Corp. ....	803	Innovative Insulation Inc. ....	838	Southco, Inc. ....	875
American Institute for Research and Development .....	804	Institute of Environmental Sciences .....	839	Superior Manufacturing Division .....	876
Ames Laboratory .....	805	Intec Research Inc. (Delta One Corp.) .....	840	Sybase, Inc. ....	877
Applied Research Laboratory/The Pennsylvania State University .....	806	Integrated Sensors, Inc. ....	841	Technology Access Report .....	878
Argonne National Laboratory .....	807	Invention Machine Corp. ....	842	Thermo Electron Tecomet .....	879
Armstrong Laboratory (US Air Force) .....	808	Kinesix .....	843	Thiokol .....	880
Austrian Trade Commission .....	809	Knowledge Express Data Systems .....	844	Third Wave Systems/Institute of Industrial Technology .....	881
BF Goodrich Aerospace/Aircraft Integrated Systems .....	810	Kollmorgen Inland Motor .....	845	Tiodize Co., Inc. ....	882
BHK, Inc. ....	811	Lawrence Berkeley Laboratory .....	846	US Air Force (Science & Technology) .....	883
Best Manufacturing Practices .....	812	Los Alamos National Laboratory .....	847	US Army Armament Research Development & Engineering .....	884
BMDO Office of Technologies .....	813	Machida Inc. ....	848	US Army ATC Aberdeen Test Center .....	885
Bosma Machine and Tool Corporation .....	814	Meridian Laboratory Inc. ....	849	US Army Dept. of Army Research Labs .....	886
Brookhaven National Laboratory .....	815	Micro Surface Corporation .....	850	US Army TARDEC/ National Automotive Center .....	887
Center for Research on Parallel Computation ..	816	Moscow Space Club (Russian Space Agency) ..	851	US Department of Agriculture, Agricultural Research Service .....	888
Centro Estero Camere Commercio Piemontesi .....	817	NASA .....	852	US Department of Commerce .....	889
College, Industry, Government Technology Transfer Committee (ASEE) .....	818	Nanophase Technologies Corp. ....	853	US Department of Energy, Kansas City Plant (operated by Allied Signal) ..	890
COSMIC Dept./University of Georgia .....	819	National Security Agency .....	854	US Department of Energy, National Renewable Energy Lab (EERE) .....	891
CSERIAC .....	820	National Space Society .....	855	US Department of Energy, Office of Clean Coal Technology .....	892
Cybernet Systems .....	821	National Technology Transfer Center .....	856	US Department of Energy, Office of Special Technology .....	893
DOE Nevada Laboratories(EG&G Energy Measurement) .....	822	Naval Research Laboratory .....	857	US Department of Energy, Office of Technology Utilization .....	894
DuPont Company .....	823	Navy Research, Development, Test, and Evaluation .....	858	US Department of Energy, OTD/Triodyne .....	895
EWI (Edison Welding Institute) .....	824	Novespace .....	859	US Department of Interior (US Bureau of Mines) .....	896
Electronic Displays Inc. ....	825	Oak Ridge Centers for Manufacturing Technology .....	861	United States Industry Coalition, Inc. ....	897
Environmental Protection Agency .....	826	Office of Naval Research/PEBB Program .....	860	United States Navy SBIR Program .....	898
Federal Aviation Administration Technology Transfer Office .....	827	Olympus America Inc./ Industrial Fiberoptics Div. ....	862	University of Wisconsin—Madison .....	899
Federal Highway Administration .....	828	Optics Technology, Inc. ....	863	USBI .....	900
Federal Laboratory Consortium .....	829	Orbital Sciences Corp. ....	864	Van Nostrand Reinhold .....	901
FLIR Systems .....	830	Pallintest .....	865	Vector Fields, Inc. ....	902
Force Imaging Technologies, Inc. ....	831	Phillips Business Information, Inc. ....	866	Westinghouse Savannah River Company .....	903
GCATT (Gulf Coast Alliance for Technology Transfer) .....	832	Physical Optics Corp. ....	867		
Hasson Productions Inc. ....	833	Powertronic Systems Inc. ....	868		
Idaho National Engineering Laboratory .....	835	Princeton University Plasma Physics Laboratory .....	869		
		Proto Mfg. ....	870		
		Ramot - University Authority for Applied Research & Industrial Development ..	871		

**NEW!**

## High Resolution Digital Color Imaging

**New  
Models**

### FEATURES

- Models with up to 40,500 pictures per second
- Color and monochrome models available
- Instant slow motion replay
- Powerful post-event analysis and data reduction
- Quality, test, manufacturing, research and design

### BENEFITS

- Increase product reliability
- Production line troubleshooting
- Shorten design cycle
- Speed prototype evaluations

For more information call:

**EASTMAN KODAK COMPANY**  
MOTION ANALYSIS SYSTEMS DIVISION  
800-462-4307, Ext. 7001



**HIGH  
SPEED  
MOTION  
ANALYSIS  
FROM  
KODAK**





# Special Focus: Sensors

## Reducing Tilt-Related Errors of Inductive Proximity Sensors

Hemispheres centered in the sensing coils enable more accurate placement of the sensors.

*Marshall Space Flight Center, Alabama*

A simple modification of an inductive proximity sensor nearly eliminates the tilt-related readout error that occurs when the sensor is used to measure the thickness of a dielectric layer on a metal substrate (e.g., to measure the thickness of an insulating blanket on a boiler). The modification can take any of several forms, all of which are equivalent to the addition of a hemispherical contact surface, as explained in more detail below.

As shown in the left part of Figure 1, an inductive proximity sensor is calibrated to read zero distance from the metal substrate when the sensing coil

lies at a nominal small distance, called the "zero-offset distance," from a flat metal substrate. The sensor is also calibrated at a number of other known distances. During the zero calibration and in use, the sensing coil is fitted with a dielectric "zero ring" — a shoe that, when placed in contact with the substrate, keeps the probe at the zero-offset distance.

At small tilt angles, the sensor reading is nearly independent of the tilt per se. However, the reading depends on the perpendicular distance from the center of the probe coil to the surface of the metal substrate, and this distance can

depend on the tilt under some circumstances. For example, the right part of Figure 1 shows how a tilt-related error can occur when the sensor is used to measure the minimum thickness of an uneven dielectric layer. Because of the unevenness in the thickness and the resulting tilt, the perpendicular distance is altered such that the zero-offset location of the probe corresponds to a thickness greater than the minimum thickness that one seeks to measure. As a result, the thickness reading of the sensor is too high.

Figure 2 shows a sensor modified to reduce the tilt-related error. The zero

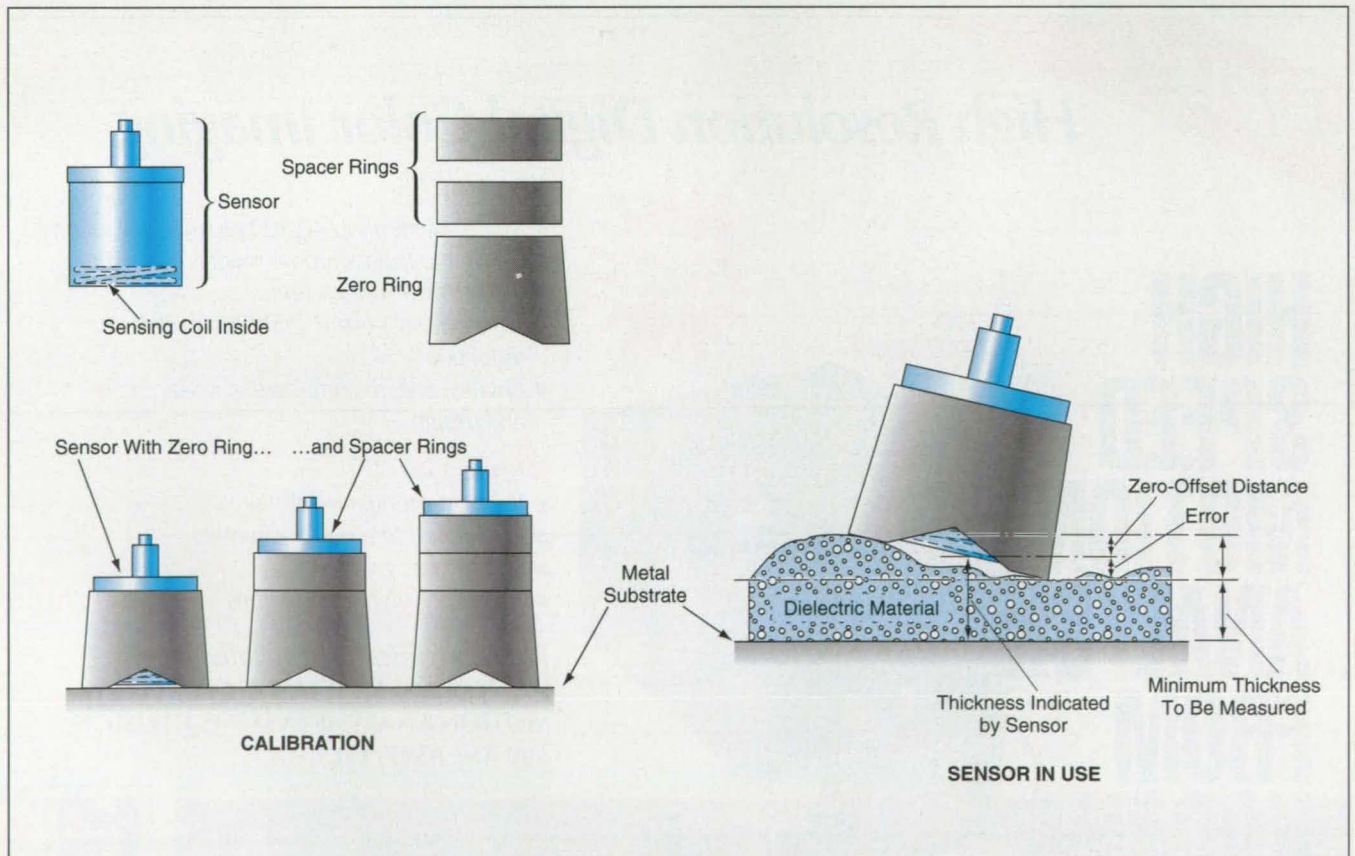
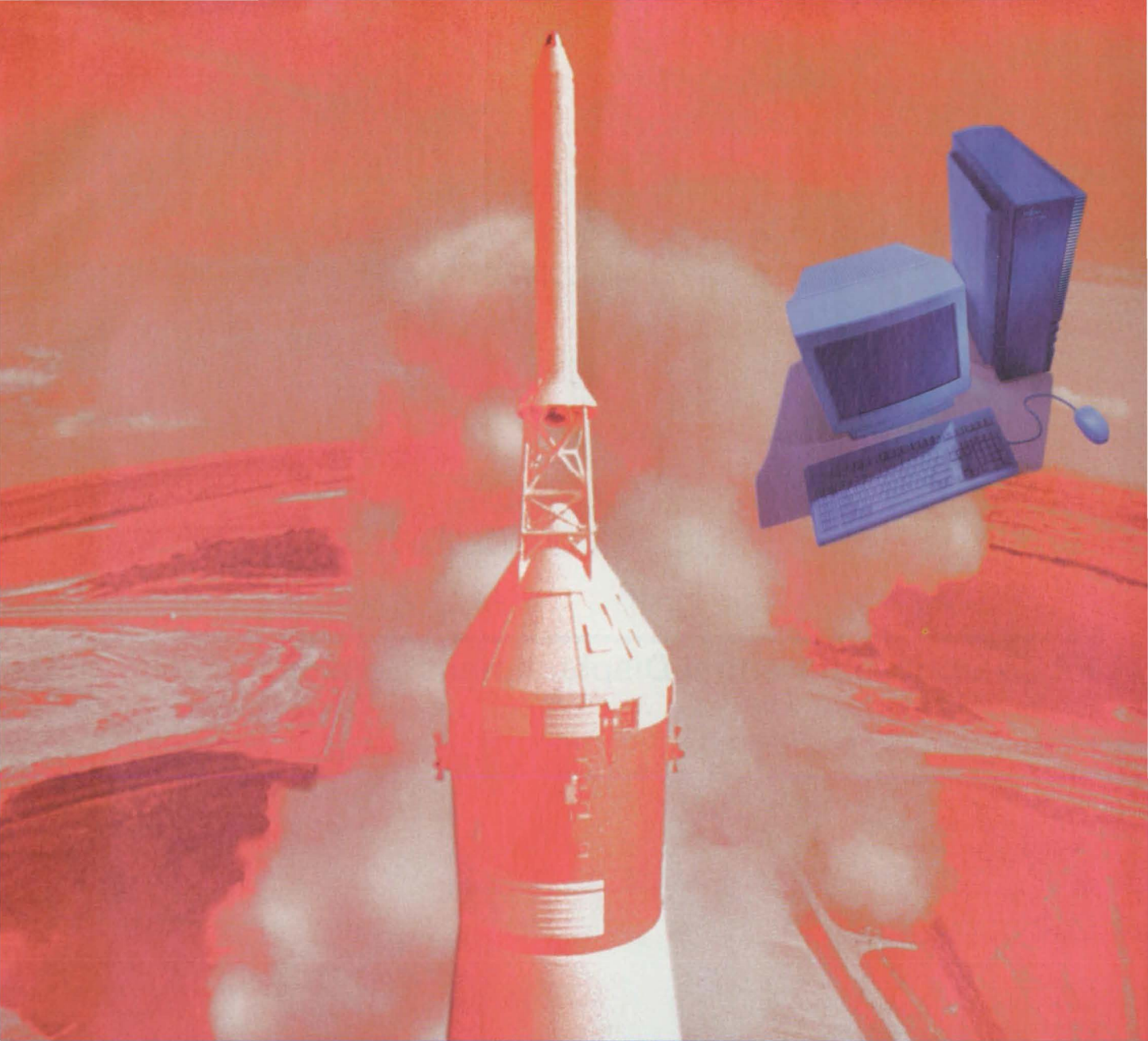

Figure 1. The **Thickness Indicated by the Sensor** differs from the minimum thickness that one seeks to read when the surface of the dielectric layer is uneven.



## Actually, you do have to be a rocket scientist to appreciate it.

Introducing the Fujitsu™ HALstation™ 300 Series.

A system that can do in hours what others would be lucky to accomplish in days.

We're not suggesting that using the HALstation 300 will get you the Nobel Prize — but it will get you in the running that much faster.

After all, we're talking about the world's first 64-bit SPARC™/Solaris® — compatible workstation. An environment that can blow right past 32-bit workstations as if they were standing still.

At the heart of the system is the first 64-bit implementation of Solaris 2.4,

our very own SPARC 64/OS™ 2.4. An OS capable of making your existing applications fly.

One that's so compatible, we guarantee it'll run your favorite Solaris programs, or your money back.

Here's something else to consider. Responsive service and support. We've got it where the other SPARC environments don't even come close.

The HALstation 300 Series. It may not be the normal way to work, but it's probably the ideal way for somebody with a sizable I.Q. like yours.

Don't be normal. Call today for more information, 1-800-425-0329.



Not your norMAL WorkStatiON.

For More Information Write In No. 623

ring is removed; in its place, a dielectric contact knob with a hemispherical surface is attached. The hemispherical surface is centered at the center of the coil and has a radius equal to the zero-offset distance. The contact knob can be placed in contact at the desired measurement location on the dielectric layer to be measured, ensuring that the center of the coil lies at the correct zero-offset perpendicular distance from the desired measurement point. Thus, the perpendicular distance indicated by the probe readout equals the thickness that one seeks to measure.

This work was done by Glenn M. Cotty, Jr., of Lockheed Martin for Marshall Space Flight Center. For further information, write in 77 on the TSP Request Card. MFS-31092

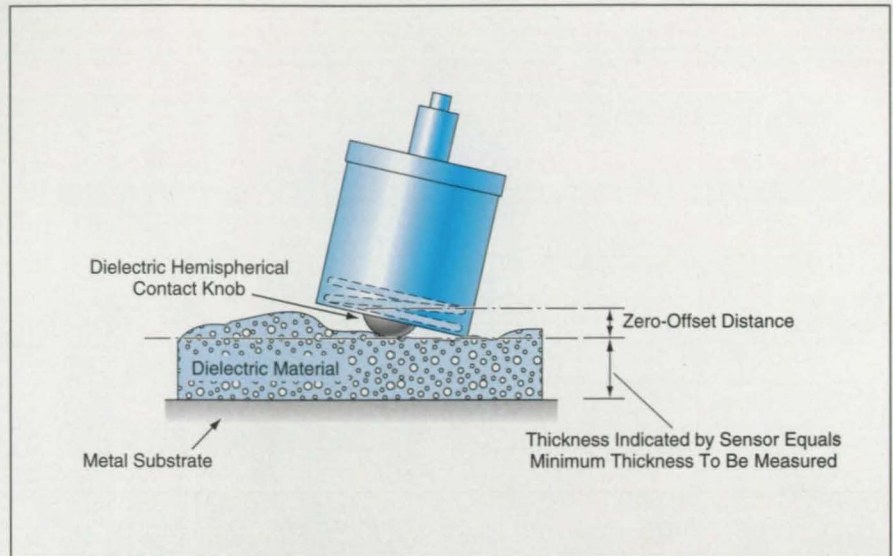

Figure 2. The Sensor Indicates the True Thickness when equipped with a hemispherical contact knob that ensures the correct zero-offset distance at the measurement location.

## Fiber-Optic Differential Displacement Sensor

Sensitivity to displacement is increased, while sensitivity to temperature is decreased.

Langley Research Center, Hampton, Virginia

The figure illustrates schematically a dual fiber-optic sensor for measuring small relative displacements of two proximate objects along a common surface. In the original application for which the dual sensor was devised, the displacement is that in a skin-friction balance on an aerodynamic surface.

The dual sensor comprises two fiber-optic sensors in a differential configuration that increases its sensitivity to displacement while decreasing its sensitivity to thermal expansion and contraction. Each component sensor includes a gradient-index-of-refraction (GRIN) lens mounted on one of the two proximate objects, an opaque/clear grating attached to the lens, and an opaque/clear grating attached to a reflective surface on the other object.

In the case of a single sensor, light supplied via a multimode optical fiber is collimated by the lens, then travels to the reflective surface, then is returned to the lens. The lens focuses the returned light into the optical fiber. The light then travels back along the fiber to a photodetector. The amount of light returned to the lens and, thus, the output of the photodetector, varies in proportion to the degree of overlap of the gratings. Therefore, a change in the output is indicative of the relative lateral displacement of the two gratings and the objects on which they are mounted.

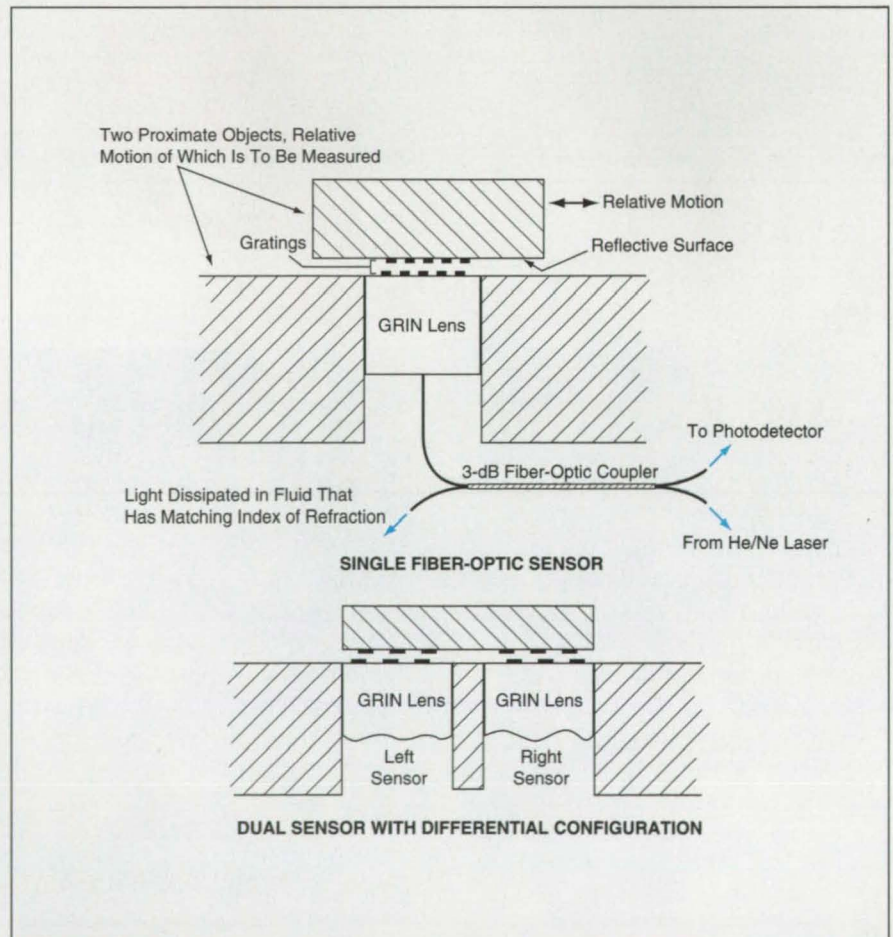

In this Fiber-Optic Differential Displacement Sensor, the differential configuration doubles (in comparison with a single sensor) the sensitivity to displacement and cancels the effect of a change in temperature.

OK, so power supplies aren't the most *exciting* things in the world.



\$995  
U.S. list price

©1996 Hewlett-Packard Co. T1MP10031/AS/ATB

But programmability, triple outputs and clean power at this price is at least *interesting*, isn't it?

**Getting more than you expect for less than you expect is never boring.**

We don't think you'll jump up and dance at the news, but we do think you'll recognize the great value offered by the new HP E3631A triple dc output supply.

The triple outputs with 80 W total power (0 to ±25V, 1A; 0 to 6V, 5A) give you lots of flexibility. The built-in HP-IB and RS-232 ports make it ready for automation.

And low noise and tight 0.01% regulation give you clean power you can count on for better measurements.

**This family's full of interesting characters.**

The HP E3631A is part of the HP E3600-series, value-priced bench power supplies that offer a wide range of functions and power ratings. The engineers at HP DIRECT can help you select the one that fits your needs perfectly.

Take advantage of our on-line pre-sales service for help with all your power supply purchasing questions. E-mail us at [tmo\\_help@hp-usa-om7.om.hp.com](mailto:tmo_help@hp-usa-om7.om.hp.com), and we'll send you answers within 24 hours.

**HP DIRECT: the fast, easy way to put more power on your bench.**

**"Let's talk power supplies."  
1-800-452-4844, Ext. 1265.**

Check out our on-line HP Basic Instruments (BI) Catalog at <http://www.hp.com/info/bi01>.



There is a better way.

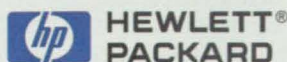

In the case of the dual sensor, two identical gratings are attached to the reflective surface, each one facing one of the fiber-optic sensors. The two sets of grating patterns are arranged as mirror images of each other, so that when the two objects move relative to each other, the grating overlap in one sensor increases (with consequent increase in output) while the overlap in the other sensor decreases (with consequent decrease in output). The output of one sensor is sub-

tracted from the other, yielding double differential output; that is, double the sensitivity of a single sensor.

Moreover, the arrangement is such that when the two objects are in the nominal middle or neutral relative position, the overlap in both gratings is 50 percent. Thus, subtracting the outputs of the photodetectors of the two sensors at the middle position yields a null reading.

If the temperature of either proximate object changes, then thermal expansion

or contraction causes the degrees of overlap of the gratings in both sensors to increase or decrease by equal amounts. Consequently, both photodetector outputs increase or decrease by the same amount, and the net output signal obtained by subtracting them does not change.

*This work was done by Ping Tcheng of Langley Research Center. No further documentation is available. LAR-14241*

## Advanced Triangulation Displacement Sensors

Measurements are expected to be accurate to within nanometers.

*Marshall Space Flight Center, Alabama*

Advanced optoelectronic triangulation displacement sensors are undergoing development. In comparison with other optoelectronic triangulation displacement sensors, these are highly miniaturized, more stable, more accurate, and relatively easy to use. Moreover, these sensors incorporate wide-band (frequency response up to 10 kHz) electronic circuits that are suitable for real-time monitoring and control of displacements. In principle, these sensors could be mass-produced at relatively low unit cost.

A typical sensor of this type (see figure) contains as many as three laser diodes of different wavelengths for generating beams of light to be used in triangulation. Beam splitters combine the three laser beams, then transmitting lenses collimate the combination beam into a narrow beam that makes a small spot of light on the surface, the displacement of which is to be measured. Light reflected from the surface at the spot is intercepted by receiving lenses, which focus the light to a small spot on a position-sensitive photodetector (PSP). By the basic principle of triangulation, the position of the spot of light on the PSP is related in a known way to the distance from the sensor to the spot of light on the surface.

The lenses are fabricated, variously, as binary and/or gradient-index optics; they feature precise optical designs that correct for astigmatism and provide light-spot sizes that range from 1  $\mu\text{m}$  to 1 mm, depending on the required fineness or coarseness of detail required. With suitable design of the lenses, spatial filtering of the transmitted and reflected beams of light, and the choice of a super-linear-response PSP, it should be possible to measure the sensor-to-surface distance to within 2 nm.

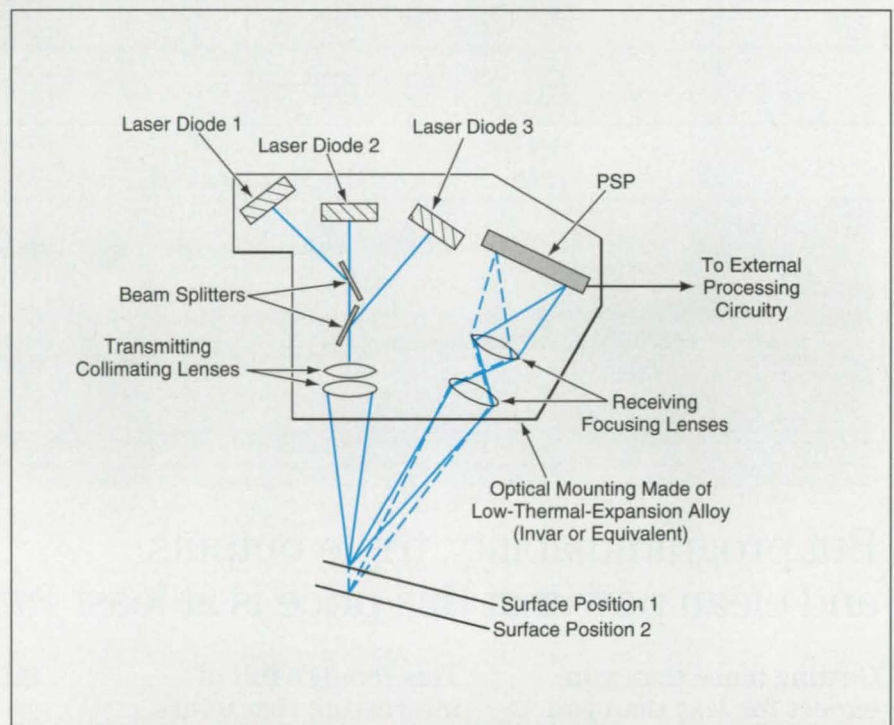

An **Advanced Triangulation Sensor** is typically 1/100 to 1/10 the size of triangulation sensors that have been used until now.

The analog output of the PSP is amplified, conditioned, and digitized for processing by external circuitry. It should be noted that changes in the finish and/or color of the surface in question do not affect accuracy to first order, because it is the position, rather than the intensity or color of the spot of light that is measured. Digital processing of the output includes corrections for nonlinearities in the response of the PSP and for the effects of variations of temperature. These corrections are obtained initially by taking calibration measurements, and are stored in firmware (a programmable read-only memory that is part of the

digital processing circuitry).

The reason for including more than one laser diode is that by performing triangulation measurements at more than one wavelength and using the known values of the index of refraction of a transparent or semitransparent surface layer at those wavelengths, one can measure not only the distance to the surface but also the thickness of the surface layer. For this purpose, the outputs of the laser diodes are modulated at different phases, so that the corresponding PSP outputs can be processed in synchronism to obtain the triangulation data for the different wavelengths.

Potential applications for these advanced triangulation sensors are numerous. For example, the surface of a precise mirror undergoing fabrication can be measured directly to better than 1/12 of a wavelength of 830 nm by scanning such a sensor over the surface, using the same mounting structure that has been used to generate and polish the mirror surface. Semiconductor wafers can be measured before and after processing to measure stress-induced warp and bow. Because of their wideband electrical characteristics, these sensors could be used as real-time position sensors or precise feedback control of scanning, chopping, and focusing motions of optical components, including focusing

of secondary mirrors of astronomical telescopes. A possible industrial application might lie in measuring runout of a rotating shaft or other moving part during fabrication in a "zero-defect" manufacturing system, in which the measured runout is automatically corrected.

*This work was done by Wade M. Poteet and Harold K. Cauthen of System Specialists, Inc., for Marshall Space Flight Center. For further information, write in 10 on the TSP Request Card.*

*Inquiries concerning rights for the commercial use of this invention should be addressed to the Patent Counsel, Marshall Space Flight Center; (205) 544-0021. Refer to MFS-26324.*

## CMOS Active-Pixel Image Sensor With Intensity-Driven Readout

Readings from pixels would be taken in order of decreasing intensity.

*NASA's Jet Propulsion Laboratory, Pasadena, California*

A proposed complementary metal oxide/semiconductor (CMOS) integrated-circuit image sensor would automatically provide readouts from pixels in order of decreasing illumination intensity. Heretofore, no image sensor was capable of performing this function; the closest

approximation to this function was provided by image sensors that gave the addresses of pixels above preset threshold levels.

The proposed image sensor could be operated in an integration mode. Its unique function would be particularly

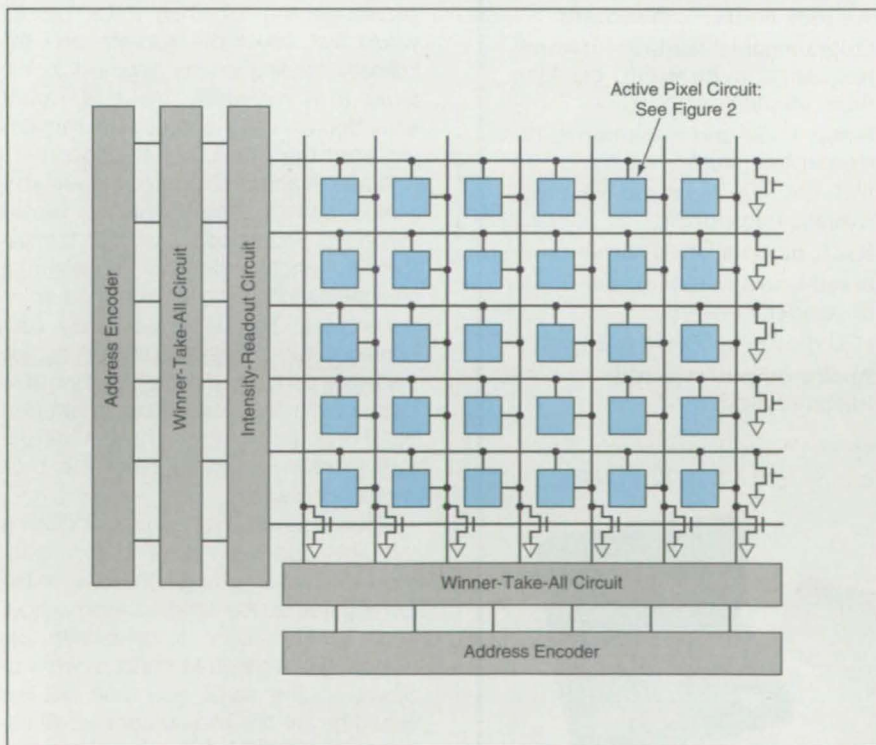
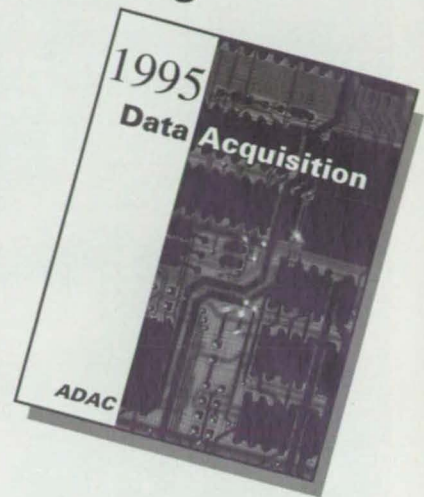

Figure 1. This CMOS Integrated-Circuit Image Sensor would provide readouts from pixels in order of decreasing intensity.

## FREE Data Acquisition Catalog



PC and VME data acquisition catalog from the inventors of plug-in data acquisition. Featuring new low-cost A/D boards optimized for Windows, DSP Data Acquisition, and the latest Windows software. Plus, informative technical tips and application notes. Call for your free copy 1-800-648-6589

## ADAC

American Data Acquisition Corporation  
70 Tower Office Park, Woburn, MA 01801  
phone 617-935-3200 fax 617-938-6553  
info@adac.com

# Polaroid Ultrasonic Sensing Enters a New Frontier.



## Piezo Transducers

Polaroid welcomes you to a new age of ultrasonics. Our rugged 9000 Series Piezo transducer is designed for sensing in challenging environments. It lets you use ultrasonics where you may never have thought possible, even in level measurement involving abrasive substances or corrosive chemicals.

- Applications include: automotive vision assistance, security/lighting, agricultural equipment and level measurement
- Features include: Sealed, water-resistant durability, 15° x 40° asymmetrical beam pattern, high sensitivity and flexible mounting

## Developer's Kit

Now, integrating ultrasonic sensors with your OEM applications is easier and faster than ever. Specialized configuration software and a microprocessor let you program ranging parameters, a process that once took hours . . . in seconds.

- Programmable features: transmit frequency; pulse width; blanking time; amplifier gain
- Range 1" - 50' and resolution  $\pm 1\%$  over entire range
- Includes new Piezo and two electrostatic transducers
- RS232 port/socketed eeprom
- Bread board suited for user-developed circuitry
- LCD display in Metric or English
- Analog output/externally triggered input

Original Designer's Kit, OEM Kit and components are also available. For technical assistance call 617-386-3965. To order call 1-800-225-1000.

Price is ~~\$345.00~~

Special price **\$299.00**

Limited time offer.

Price subject to change without notice.

# Polaroid®

©1993 Polaroid Corporation  
Polaroid®



useful in a number of image-sensing tasks, including diffractive laser range-finding, three-dimensional imaging, event-driven readout of sparse sensor arrays, and star tracking. In these tasks, it is desirable to determine the location and intensity of the brightest pixel in an image as quickly as possible and to then read out the rest of the pixels in order of decreasing intensity for use in an integration mode.

The proposed image sensor (see Figure 1) would include a two-dimensional array of active pixel circuits, plus intensity-read-out, winner-take-all, and address-encoder

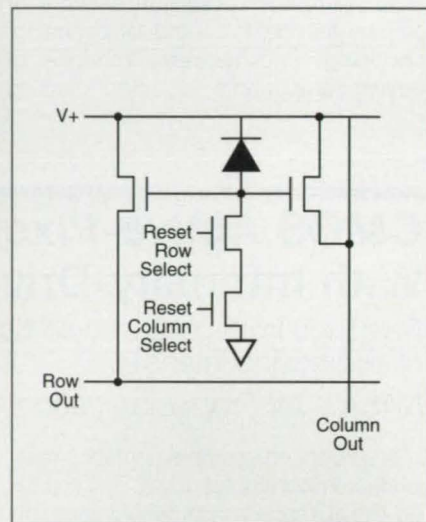

Figure 2. An **Active-Pixel Circuit** like this one would be located at the intersection of each row and column.

circuits. Acting together, these circuits would first select the address and the intensity reading of the brightest in the array, then repeatedly make a similar selection of the brightest pixel remaining after the previous selection.

A typical active pixel circuit in the proposed sensor (see Figure 2) would include a photodiode and four transistors. The photodiode would consist of a reverse-biased  $p^+$ -doped region in an  $n$ -doped well. The diode would be connected to two  $n$ -channel gates in source followers connected to a common row and column line. The diode would also be connected to two  $n$ -channel transistors in series used to reset the pixel when selected.

After all pixels in the array (including this one) had been reset to 0 V, photocurrent would charge the source-follower gates during an integration period, causing the source follower with the highest gate voltage to conduct while all others in the same row and column would be cut off. The winner-take-all circuits would select the column and row that intersect at the pixel with the great-



**New From Astro-Med... World Leader in Chart Recorders**

# NO CHART!

## **INTRODUCING AstroDAQ™**

Astro-Med's new AstroDAQ is a complete and *ready-to-use* system for acquiring, conditioning, analyzing, and networking data from a wide variety of applications in industry, aerospace, and science.

Up to 30 channels of data can be acquired by each AstroDAQ and up to 10 AstroDAQ systems can be networked for recording up to 300 channels of information. The data is

acquired and conditioned with Astro-Med's advanced DSP-based "front end". The internal hard drive of the AstroDAQ stores the data for immediate or subsequent analysis on a PC.

And, if continuous hard copy is required, a *real-time* recorder featuring Astro-Med's famous direct thermal technology is a convenient option.

- AstroDAQ is a *total system*, ready-to-use, complete with Windows based AstroLINK™ software for control and data review
- Internal sampling and hard drive (1 or 4 Gigabyte) offloads your PC for other duties and guarantees the bandwidth
- DSP built into each signal conditioner provides virtually unlimited programmable filtering
- High speed network interface accommodates up to 10 AstroDAQs with a total of 300 channels
- Sample rate up to 5 kHz unaffected by number of channels acquired
- Internal battery comes standard and provides a UPS
- Real-time hard copy with optional Astro-Graph® direct thermal recorder
- Portable as well as rack mount versions

Call, fax, or write for brochure today!



**Astro-Med, Inc.**

Astro-Med Industrial Park  
West Warwick, Rhode Island 02893  
Phone: (401) 828-4000 • Toll Free (800) 343-4039  
Fax: (401) 822-2430 • In Canada Telephone 1-800-565-2216

**Astro-Med is System Certified to ISO 9001**

**Sales and Service Centers throughout the U.S., Canada and Europe. Dealers located throughout the world.**

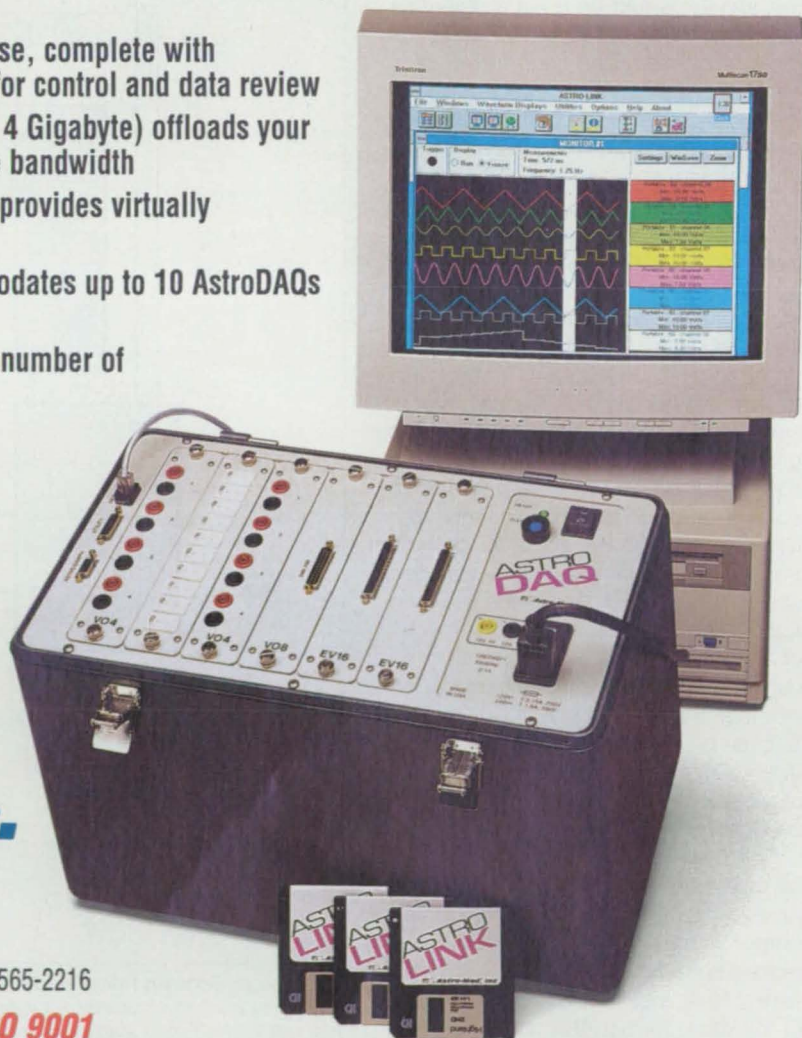

est output (the winning pixel). The intensity reading and the encoded address of the winning pixel would be read out, and the winner-take-all circuits would enable the "select" signals to reset the winning pixel, removing it from the selection

process. The foregoing functions would then be repeated until the intensity signals from a desired number of pixels had been read out.

*This work was done by Harry T. Langenbacher, Eric R. Fossum, and*

*Sabrina Kemeny of Caltech for NASA's Jet Propulsion Laboratory. For further information, write in 61 on the TSP Request Card. NPO-19539*

## ▶ High-Speed Binary-Output Image Sensor

Photodetector outputs are digitized by circuitry on the same integrated-circuit chip.

*NASA's Jet Propulsion Laboratory, Pasadena, California*

A developmental special-purpose binary-output image sensor is designed to capture up to 1,000 images per second, with a resolution greater than  $10^6$  pixels ( $1,024 \times 1,024$  to be precise) per image. A lower-resolution but higher-frame-rate (8,000 images per second) prototype of the sensor contains a  $128 \times 128$  array of photodiodes on a complementary metal oxide/semiconductor (CMOS) integrated-circuit chip. In the special application for which it is being developed, this sensor would be used to examine helicopter oil to determine whether the amount of metal and sand in the oil is sufficient to warrant replacement. In this application, pulsed laser light at a wavelength of 850 nm would be directed through a sample of oil and onto the array of photodiodes.

The figure illustrates the major functional blocks of the sensor. During operation, the photodiodes are reverse-biased, and are partially discharged, from their reset voltage, by photogenerated electrons. In response to timing and control signals, a row shift register selects the current row of pixels (photodiodes). An active in-pixel source-follower buffers the photodiode voltage and drives the column line. Circuitry on all 128 columns detects the resulting changes in the voltages across the photodiodes at the selected row/column intersections. A digital "1" or "0" is produced by comparator circuitry for each column, depending on whether the pixel signal in question is above or below an externally set threshold level. Either 1-bit or 2-bit representations of the analog signals can be obtained.

The resulting binary data signals for all columns in the current row are loaded in parallel into a register, for output in either of two formats. In one higher-speed format, the data are available as a serial stream of 16 Mb/s; in the other format, the data are multiplexed at a width of 8 bits at a clock

rate of 16 MHz for a 128 Mb/s effective data rate.

*This work was done by Eric Fossum, Roger A. Panicacci, Sabrina E. Kemeny, and Peter D. Jones of Caltech for*

**NASA's Jet Propulsion Laboratory.** For further information, write in 92 on the TSP Request Card. NPO-19520

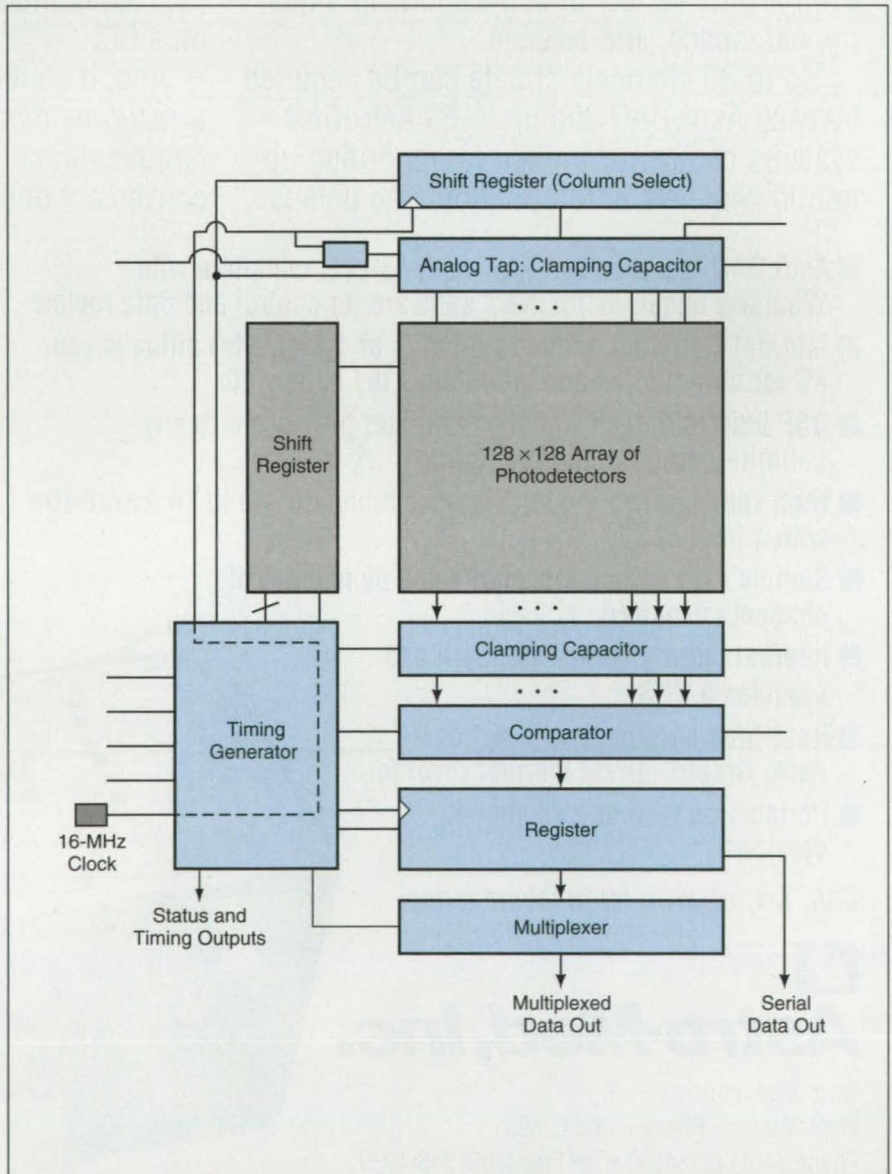

This **Image-Sensing Integrated-Circuit Chip** generates most of its internal control and timing signal from an externally supplied 16-MHz clock signal. The chip also produces chip-status and frame-timing signals. The short lines at the right and left sides of the figure indicate various control and bias connections.

# The fast track from idea to implementation.

## SIMULINK<sup>®</sup>

**Figure** CD-ROM disk magnified 13,000 times, showing "data pits" struck by the laser beam (red circle).

**Requirement** Track following within  $1 \times 10^{-7}$  meters during portable operation. (Like driving a car at mach four and staying on course within half a millimeter.)

(Photograph courtesy of Philips Electronics N.V., Netherlands.)

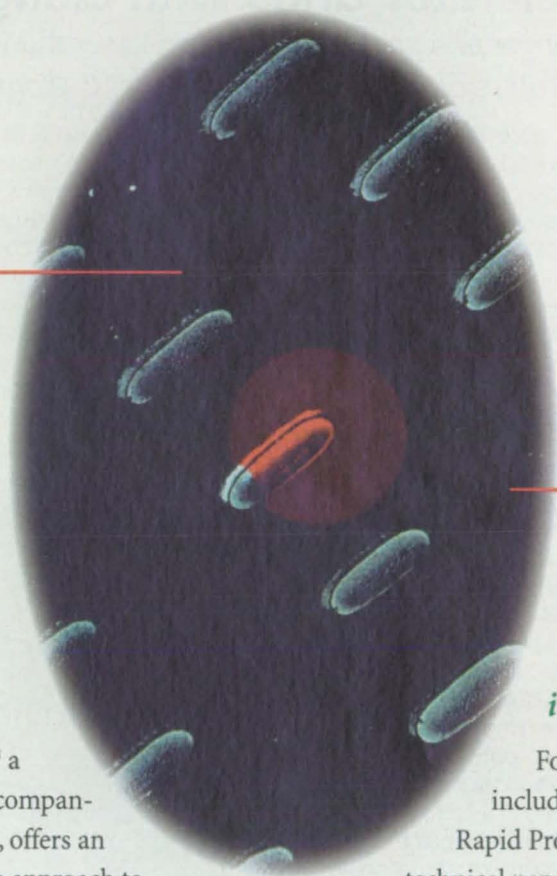

**S**IMULINK is a powerful, interactive environment for system modeling, analysis, and simulation. Over 10,000 engineers worldwide have proven SIMULINK to be effective in the design of powertrains, aircraft, satellites, and industrial-process control systems.

### Create models graphically

With SIMULINK's intuitive GUI, systems can be modeled quickly and easily. Just drag and drop icons into block diagrams—without writing a single line of code.

### Extensive block libraries

Over 200 built-in blocks, including linear, nonlinear, continuous-time and discrete-time, help simplify model building and provide accurate simulations.

Additional blocksets are also available for DSP design or fixed-point modeling and simulation.

### Real-time testing

Real-Time Workshop<sup>™</sup>, a SIMULINK companion product, offers an open system approach to rapid prototyping by generating optimized, highly portable C code directly from block diagrams.

SIMULINK provides the right tools to model and simulate your entire system including the plant, controller, actuators, and sensors.

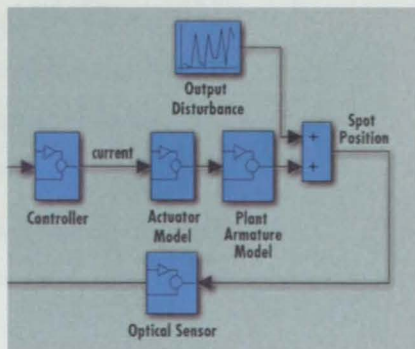

### Call for free technical information

For a free kit that includes a Guide to Rapid Prototyping, a technical paper on servo track following, and the SIMULINK brochure, please call:  
**(508) 653-1415**



**Result** "Design and Implementation of a QFT Controller for a Compact Disc Player," *Journal of Systems Engineering*, Vol. 4, 1994.

**MathWorks Products Used** SIMULINK, MATLAB<sup>®</sup>, QFT Toolbox, and other toolboxes.

The  
**MATH  
WORKS**  
Inc.

developers of MATLAB and SIMULINK

24 Prime Park Way, Natick, MA 01760  
Tel: (508) 653-1415 Fax: (508) 653-6284

E-mail: info@mathworks.com Web: http://www.mathworks.com



# Electronic Components and Circuits

## Ion-Accelerator Grids With Elongated Holes

Grids are stronger and costs of fabrication lower than for grids with circular holes.

NASA's Jet Propulsion Laboratory, Pasadena, California

Ion-accelerator grids have been designed and fabricated with elongated holes instead of the circular holes used heretofore. Although the grids are made of lightweight carbon/carbon composites and were conceived for use in ion thrusters for spacecraft, they could also be made of other materials and installed in industrial ion accelerators for material-processing applications. In comparison with circular holes, the elongated holes offer advantages of lower costs of fabrication and the option to increase the open-area fractions of the grids, thereby increasing the output ion currents that can be extracted through the grids.

As shown in the upper part of the figure, each hole has a length  $l$  and consists of a rectangular center section of width  $h$  with semicircular end segments. Adjacent holes are separated by a web of thickness  $w$ . The dimensions  $l$ ,  $h$ , and  $w$  can be varied to obtain a specified open-area fraction and to obtain a specified number of holes in a grid of a specified diameter. Fewer elongated holes are needed to obtain the same open-area fraction as that provided by circular holes of a given diameter and spacing.

Typically, the holes are cut one at a time by electrical-discharge machining, which takes the same amount of time to make an elongated hole as to make a circular hole. Thus, an elongated-hole design offers the opportunity to reduce fabrication time and cost in approximate proportion to the reduction in the number of holes relative to a circular-hole design.

The following example illustrates the advantages of the elongated-hole concept. A state-of-the-art ion-engine grid of 15-cm diameter contains approximately 4,500 circular holes, with an open-area fraction of 67 percent. The diameter of the holes is about 1.9 mm, and the thicknesses of the webs between holes can be as little as 0.3 mm. These dimensions impose severe design requirements and make fabrication expensive. The same open-area fraction can be achieved with only 1,100 elongated holes like those shown in the lower part of the figure, for which  $l = 6.35$  mm,  $h = 1.9$  mm, and  $w = 0.56$  mm.

Thus the same open-area fraction can be maintained with a webbing thickness almost twice as large as for the circular holes. Therefore, a grid using an elongated hole design is stronger and easier to fabricate than one using a circular hole design because the webs are thicker. The number of elongated holes being slightly less than 1/4 the number of circular holes, machining of the elongated holes should cost only about 1/4 as much.

In cases in which smaller  $w$  can be tolerated, open-area fractions could be increased, with corresponding increases in output currents.

*This work was done by Juergen Mueller of Caltech for NASA's Jet Propulsion Laboratory. For further information, write in 38 on the TSP Request Card. NPO-19336*

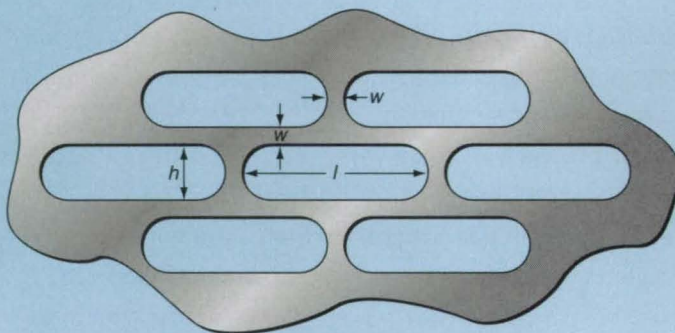

ELONGATED HOLE PATTERN

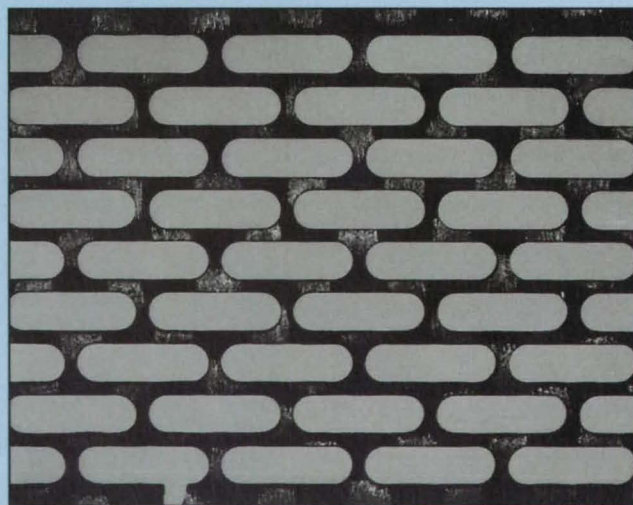

PHOTOGRAPH OF ELONGATED HOLES IN A CARBON/CARBON COMPOSITE GRID

**Elongated Holes** can be designed to provide open-area fractions equal to or greater than those of circular holes.

## Lightweight Cathodes for Nickel Batteries

Fibrous cathode mats accommodate more charge per unit mass.

Lewis Research Center, Cleveland, Ohio

Lightweight cathodes for rechargeable nickel-based electrochemical cells are undergoing development. In these cathodes, mats of nickel fibers (instead of the sintered nickel plaques in older cathodes) are the substrates that provide structural support of, and electrical contact with, the active cathode material. The fibrous nickel cathodes offer specific energies greater than those of sintered nickel plaque cathodes; for example, a representative 48-A·h nickel/hydrogen cell made with a fibrous nickel cathode exhibits a specific energy of 90 W·h/kg, while the same cell made with a sintered nickel plaque cathode exhibits a specific energy of 50 W·h/kg.

The fibrous cathodes could be used in a variety of nickel-based cell systems, including nickel/cadmium, nickel/zinc,

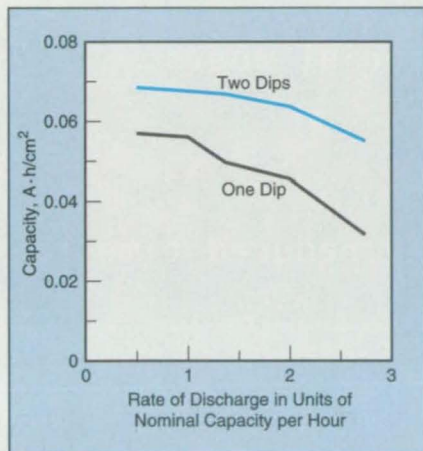

**Two Dips** in a solution of cobalt nitrate have been found to increase the capacity of a fibrous-nickel-substrate cathode even more than does a single dip.

nickel/metal hydride, and nickel/hydrogen. These electrodes are expected to be used in rechargeable batteries for applications in which weight is a major concern, including laptop computers, cellular phones, flashlights, soldiers' backpacks, and electric vehicles.

Like a sintered nickel cathode substrate, a fibrous nickel cathode substrate provides ample surface area for a coating with nickel hydroxide, which is the active electrode material. However, in comparison with a sintered substrate of the same capacity, a fibrous nickel substrate weighs less. Typically, the nickel fibers are 2  $\mu\text{m}$  in diameter. In fabrication of a cathode, a mat of nickel fibers is electrochemically impregnated with nickel hydroxide in an aqueous

solution of 1.5 molar nickel nitrate, 0.175 molar cobalt nitrate, and 0.075 molar sodium nitrite at a current density of between 40 and 54  $\text{mA}/\text{cm}^2$  for an interval between 5 and 7 h at a temperature between 95 and 100  $^{\circ}\text{C}$ .

A 20-min postimpregnation dip in a solution of 1.8 molar cobalt nitrate increases the initial charge/discharge capacity of the cathode. The cathode is

then subjected to eight cycles of 20-min charge and 20-min discharge at a current density of 70  $\text{mA}/\text{cm}^2$  in a solution of 26 percent potassium hydroxide. This charge/discharge treatment removes impurities from the active cathode material and gives the active material the electrochemical analogue of

(continued on page 38)

# WHY

► When a customer has a problem monitoring, measuring and recording *specific* information, we make it a point to be part of the solution.

# IT PAYS

► As a result, our Info Loggers have flown in airplanes, raced with Indy Drivers, driven with truckers and have even been into outer space. Our loggers operate on top, under and in buildings, in tropical and sub-zero temperatures, in and out of water and just about any place a mind can imagine.

# TO TALK WITH

► They monitor, measure and record temperature, relative humidity, AC and DC current, Pulse Counts, Voltage, Pressure, Flow, RPM's and more.

# THE SOLUTION PEOPLE

► Compatible software downloads all stored information to a PC for quick data analysis using graphical and spreadsheet presentation formats. Special requirement? Talk to *the solution people* at ACR Systems Inc. Your affordable solution may be closer than you think.



**AT ACR**  
**SYSTEMS INC.**

Unit 210, 12960 84th Avenue  
Surrey, British Columbia, V3W 1K7 Canada

Phone: (604) 591-1128 or 1-800-663-7845. Fax: (604) 591-2252

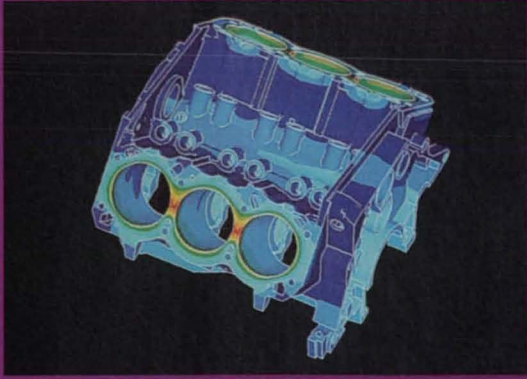

# This is the engine that Jack built.

This is the engine that Jack built using whiz-bang flexible engineering software. This is the engine that Jack built using whiz-bang flexible engineering software that slashed development time. This is the engine that Jack built using whiz-bang flexible engineering software that slashed development time and whacked the heck out of material costs. This is the engine that Jack built using whiz-bang flexible engineering software that slashed development time, whacked the heck out of material costs, and dramatically reduced time to market. This is the engine that Jack built using whiz-bang flexible engineering software that slashed development time, whacked the heck out of material costs, dramatically reduced time to market, and got the highest octane ratings from Jack's boss. This is the engine that Jack built using whiz-bang flexible engineering software that slashed development time, whacked the heck out of material costs, dramatically reduced time to market, got the highest octane ratings from Jack's boss, and set the design world on fire. This is the engine that Jack built using whiz-bang flexible engineering software that slashed development time, whacked the heck out of material costs, dramatically reduced time to market, got the highest octane ratings from Jack's boss, set the design

world on fire, and put the screws to the competition. This is the engine that Jack built using whiz-bang flexible engineering software that slashed development time, whacked the heck out of material costs, dramatically reduced time to market, got the highest octane ratings from Jack's boss, set the design world on fire, put the screws to the competition, and put Jack's company on the cover of every automotive magazine on the planet. This is the engine that Jack built using whiz-bang flexible engineering software that slashed development time, whacked the heck out of material costs, dramatically reduced time to market, got the highest octane ratings from Jack's boss, set the design world on fire, put the screws to the competition, put Jack's company on the cover of every automotive magazine on the planet, and turbo-charged Jack's career. This is the engine that Jack built using whiz-bang flexible engineering software that slashed development time, whacked the heck out of material costs, dramatically reduced time to market, got the highest octane ratings from Jack's boss, set the design world on fire, put the screws to the competition, put Jack's company on the cover of every automotive magazine on the planet, turbo-charged Jack's career, and earned Jack a raise, a window office and his own pace car at the Indy 500.

The ANSYS logo consists of the word "ANSYS" in a bold, sans-serif font. The letters "A", "N", "S", and "Y" are white, while the letter "S" is yellow. A registered trademark symbol (®) is located to the upper right of the final "S". The logo is set against a dark rectangular background.

This is the software Jack used to build his engine.

To learn more, contact us at 1.800.937.3321. Or <http://www.ansys.com>

For More Information Write In No. 622



UL HAS CERTIFICATION REGARDING ALL COMMERCIAL PRODUCTS

exercise. After the eight charge/discharge cycles, the cathode is dipped again in cobalt nitrate solution to increase the capacity even more (see figure). Finally, the cathode is installed in a cell, along with a sintered nickel plaque

anode, an asbestos separator between these two electrodes, and an electrolyte.

This work was done by Doris L. Britton of Lewis Research Center. For further information, **write in 60** on the TSP Request Card.

Inquiries concerning rights for the commercial use of this invention should be addressed to the Patent Counsel, Lewis Research Center; (216) 433-2320. Refer to LEW-15817.

## Megavolt, Multigigawatt Pulsed Plasma Switch

An inverse-pinch configuration would provide for dispersal of current over a relatively large area. Langley Research Center, Hampton, Virginia

The figure illustrates a plasma switch that has been proposed for use in a high-voltage, high-current pulse power system. The switch is required to hold off a potential of 1 MV when not triggered. The switch is required, when triggered, to transfer pulses with energies of 36 kJ apiece and durations of 1  $\mu$ s (corresponding to a peak power of about 36 GW) at a repetition frequency of 10 Hz from a pulse-forming transmission line that has an impedance of 2  $\Omega$ . This severe combination of requirements can be satisfied only by a spark-gap switch near the upper limit of its performance. The proposed switch would be a spark-gap switch but would differ radically from conventional spark-gap switches. It has been designed not only to outperform a conventional spark-gap switch but also to be relatively compact and lightweight.

Flat-plate input and output transmission lines would be connected to the switch and would be immersed in oil to satisfy high-voltage and impedance-matching requirements. The main current-carrying electrodes would be (1) an outer electrode shaped like a cylindrical cup with a hole in the bottom and (2) a mushroom-shaped inner electrode surrounded by (3) an insulator and a skirt of multiple ring electrodes separated by uniform gaps. This multiple-ring-electrode configuration would serve, in conjunction with pressurized SF<sub>6</sub> dielectric gas, to resist electrical breakdown and thereby satisfy the 1-MV hold-off requirement. The dimensions of the electrodes are chosen, not only with regard to the hold-off requirement, but also to minimize the inductance and capacitance of the switch to achieve high switching speed (rise time required to be < 0.1  $\mu$ s).

A discharge would be triggered by use of a trigger electrode located at the base of the outer electrode. A high-voltage trigger pulse would be fed to the trigger electrode, causing a

flashover on an adjacent ceramic disk insulator. This would generate a plasma ring, which would puff up axially toward the lowest ring electrode, where it would initiate breakdown current from the outer to the inner electrode via the multiple ring electrodes; the gaps in series in the multiple-ring-electrode structure would break down simultaneously because of overvoltage caused by plasma closing of the lowest gap.

The switch is designed in an inverse-pinch configuration, which has been used in other plasma devices, but not in spark-gap switches. In the inverse-pinch configuration, the electrode and insulator surfaces are arranged so

that the ponderomotive force of the current upon itself would act to sweep the current sheet radially outward and axially upward from its initial discharge path along the multiple-ring-electrode structure. Thus, once a discharge was triggered, the current would sweep over the broad electrode surfaces instead of constricting the current sheet into filaments that cause hot spots, as in conventional spark gaps.

This work was done by Ja H. Lee of Langley Research Center and Sang H. Choi and Kyo D. Song of Source Tek, Inc. For further information, **write in 71** on the TSP Request Card. LAR-14422

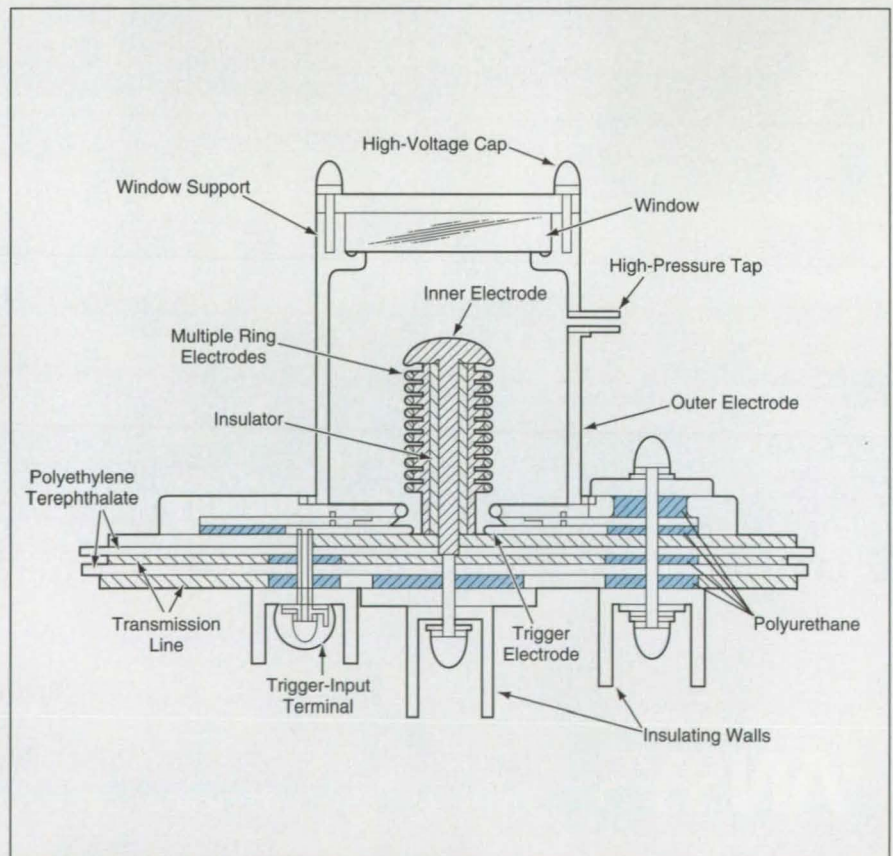

The **Plasma Switch** would feature an inverse-pinch configuration to prevent constriction of current sheets into filaments, plus a multiple-ring-electrode structure to resist high-voltage breakdown.





# COLE-PARMER® 1995-1996

CALL TOLL-FREE (800) 323-4340

Serving the Research & Technical Communities Worldwide



## COLE-PARMER® serving the RESEARCH & TECHNICAL COMMUNITIES WORLDWIDE

COLE-PARMER® gives you quality service. Our Sales associates, Application Specialists, and Customer Satisfaction representatives are always ready to give you prompt assistance.

The COLE-PARMER® catalog gives you a wide selection of more than 40,000 products for Research, Industry, and Education and it's . . .

# FREE!

The COLE-PARMER® catalog also gives you information that you can use everyday. This 1760-page resource includes technical information, conversion tables, and chemical resistance charts.

To receive your FREE 1995-1996 COLE-PARMER® catalog, fax back the coupon at left or call our literature hotline.

## (800) 443-3434

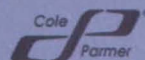

Cole Parmer®  
Instrument Company

625 E. Bunker Court Vernon Hills, IL 60061

Send us the "FAX" to get your FREE Cole-Parmer Catalog!

**FAX: (708) 549-7676**

Name: \_\_\_\_\_

Title/Mail Stop: \_\_\_\_\_

Company: \_\_\_\_\_

Address: \_\_\_\_\_

City: \_\_\_\_\_ State: \_\_\_\_\_ Zip: \_\_\_\_\_

Phone: \_\_\_\_\_ Fax: \_\_\_\_\_

NASA 1/96

For More Information Write In No. 528

For More Information Write in No. 528

# Mode Orientation Control for Sapphire Dielectric Ring Resonator

A tuning wedge breaks a quasi-degeneracy of two modes and allows selective coupling to just one mode.

NASA's Jet Propulsion Laboratory, Pasadena, California

A small sapphire tuning wedge is used in a technique for solving a mode-purity problem associated with a sapphire dielectric-ring resonator that is part of a cryogenic microwave frequency discriminator. Such a resonator is typically used to stabilize the frequency and ensure the spectral purity of a microwave signal generated by frequency multiplication from a 5-MHz quartz-crystal oscillator.

The mode-purity problem can be summarized as follows: The resonator supports whispering-gallery electromagnetic modes, which present mode degeneracies common to any circularly symmetric waveguide. Because of small geometrical imperfections that are difficult to identify, the sapphire cavity resonates in a pair of quasi-degenerate modes split by a few kHz. The random angular orientation of these modes results in uncontrolled coupling of the modes to a fixed waveguide port, whereas selective coupling of one of these modes to the port is required.

The mode orientation can be controlled by adding a perturbation that is greater than that of the geometric imperfections. In the present technique, the perturbation is added by installing a sapphire tuning wedge above the sapphire ring (see figure).

The sapphire tuning wedge changes the configuration of the dielectric medium that supports standing waves outside the resonator. The dielectric perturbation introduced by the tuning wedge becomes the dominant effect that deter-

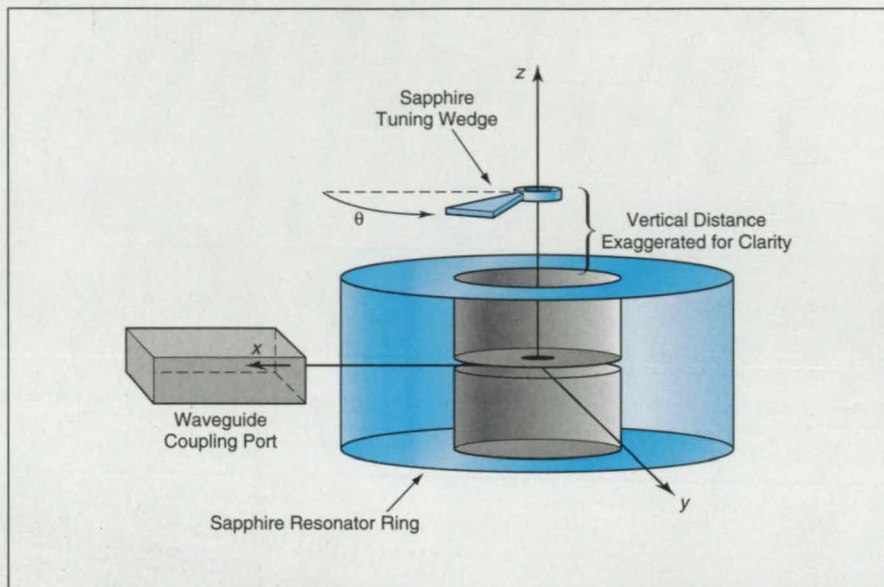

The **Small Sapphire Tuning Wedge** above the sapphire resonator ring introduces a dominant perturbation that breaks a mode degeneracy and controls angular orientation of the modes. Selective coupling to just one mode is obtained by turning the wedge to the desired angle,  $\theta$ ; the frequency is adjusted by moving the wedge to the desired height,  $z$ .

mines the circumferential alignment of the modes with respect to the waveguide coupling port. Thus, by rotating this tuning wedge, one can rotate the resonant standing-wave pattern with respect to the port to obtain coupling to only the desired mode. In addition to providing coupling control, the tuning wedge increases the frequency separation between the two quasi-degenerate modes to about 56 kHz — a feature that further reduces coupling to the undesired mode. The tuning wedge can be

mounted on an axle that enters the resonator cavity and can be rotated while the resonator is cryogenically operating in a vacuum. Furthermore, the axle can also be moved vertically to tune the resonant frequency.

This work was done by David G. Santiago and G. John Dick of Caltech, and Aluizio Prata of the University of Southern California for **NASA's Jet Propulsion Laboratory**. For further information, write in 28 on the TSP Request Card. NPO-18933

# Perforated-Layer Implementation of Radio-Frequency Lenses

The perforation pattern would be designed to achieve the required spatial variation of permittivity.

NASA's Jet Propulsion Laboratory, Pasadena, California

Luneberg-type radio-frequency dielectric lenses would be made of stacked perforated circular dielectric sheets, according to a proposal. (A Luneberg lens is a dielectric sphere, the index of refraction of which varies with distance from the center such that a beam of parallel rays incident on one face of the sphere is focused to a point on the

opposite face.) The perforations would consist of round holes distributed across the face of each sheet in a "Swiss-cheese" pattern, plus straight or curved slots that would break up the outer parts into petals in a "daisy-wheel" pattern (see figure). The holes and slots would be made by numerically controlled machining.

The basic idea is to choose the distribution of holes and slots such that at any given location within the lens, the effective local relative permittivity  $\epsilon_{\text{eff}}$  equals the square of the index of refraction prescribed by the Luneberg-lens formula. The requirement is expressed by  $\epsilon_{\text{eff}} = 2 - [(h^2 + r^2)^{1/2} / R]$ , where  $R$  is the radius of the sphere,  $h$  is the distance

# Data Acquisition Direct To Tape At 15 MBS.

51 GB *uncompressed*  
tape capacity

15 MBS sustained  
throughput,  
*uncompressed*



Fast/Wide SCSI, ESCON,  
IBM Channel, and Parallel  
Data Channel Interfaces

Rack mount configuration  
available

Built to match the speed of the fastest computer systems while providing the high capacity needed to handle massive amounts of data, the CY-9000 half-inch digital DTF drive is a performance breakthrough.

Store 51 GB on a single tape, *uncompressed*.

Save time and resources by writing directly to tape at a record-breaking speed of 15 MB per second — 54 gigabytes per hour — over a *terabyte* every day.

Choose from Fast/Wide SCSI, ESCON, IBM Channel, and Parallel Data Channel interfaces for plug

compatibility with the widest range of systems.

Available in a desktop or rack mount configuration, the drive features a 32 MB data buffer. An optional Digital Data Recorder interface provides up to 128 MB of variable rate buffer to ensure a smooth flow of data from host to drive, regardless of fluctuations in the data source.

Whatever configuration you choose, the drive will be up and running when you need it with a MTBF of 200,000 hours — the best reliability in the industry.

You'll also like the fact that the compact cartridges are widely available and easy to organize, ship, and store.

If you need it, 100% lossless data compression is available to boost tape capacity to up to 153 GB and speed to 20 MBS.

If you're serious about data acquisition, get the tape drive that's serious about performance.

Call today for more information.  
**(804) 833-9000**

**CYBERNETICS**

Tera One • Yorktown, VA 23693 • Fax (804) 833-9300

(along the optical axis) of the layer in question from the center of the sphere, and  $r$  is the distance of the location in question from the center of the layer (equivalently, the lateral distance from the optical axis).

For the purpose of this concept,  $\epsilon_{\text{eff}}$  is considered to be the volume-average permittivity in a small neighborhood around the location of interest and is given by  $\epsilon_{\text{eff}} = (\epsilon_m - 1)(1 - v) + 1$ , where  $\epsilon_m$  is the relative permittivity of the dielectric material and  $v$  is the local volume fraction of holes and slots. The distribution of the volume fraction of holes and slots that yields the required distribution of  $\epsilon_{\text{eff}}$  is given by  $v = \{\epsilon_m - 2 + [(h^2 + r^2)^{1/2} / R]\} / (\epsilon_m - 1)$ .

Of course, the validity of this concept depends on the use of a sufficient number of holes and/or slots to justify a volume average. Furthermore, each hole or slot must be much smaller than a wavelength at the radio frequency of interest so that no single one significantly affects the propagation of the electromagnetic waves passing through it.

The patterns of holes and slots must satisfy some additional practical requirements: When the layers are stacked, there must be no sealed pockets in which pressurized gas could be trapped. The holes and slots in adjacent layers

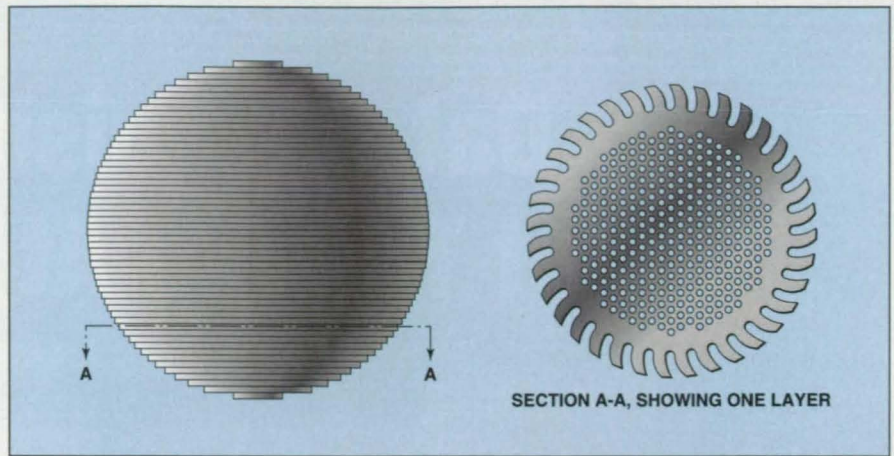

**Circular Layers of Dielectric Material** containing holes and slots would be assembled and bonded together to form a spherical dielectric lens. To save machining time, multiple sheets with identical patterns of holes and slots (e.g., sheets at the same latitude in both hemispheres) could be machined together.

must not be concentric with or parallel to each other, respectively, or else they could effectively form larger holes and slots that could affect propagation to an unacceptable degree. The patterns must also be chosen to minimize the cost of machining; for example, the number of different drill sizes should be minimized.

In stacking the perforated layers to assemble a lens, the holes could be used as alignment surfaces. The layers would

preferably be bonded together by ultrasonic welding; adhesive bonding would not be acceptable because it would introduce solvents that could affect dielectric properties.

*This work was done by Benjamin P. Dolgin of Caltech for NASA's Jet Propulsion Laboratory. For further information, write in 69 on the TSP Request Card. NPO-19217*

## Coding for Increased Density of Binary Data Stored on Disks

Interleaved bit patterns provide for bit density with low readout rates.

*NASA's Jet Propulsion Laboratory, Pasadena, California*

Interleaved bit patterns have been proposed as the basis of a scheme for increasing the density of binary data stored on disks. Unlike in some other schemes for increasing data-storage

density, the readout rate would not necessarily have to increase proportionally to the density and thus there may not be a need for correspondingly faster readout circuitry.

The bit densities of computer data-storage disks are increased to increase overall data-storage capacities. To enable rapid access to data stored on the disks, the speeds of rotation of the

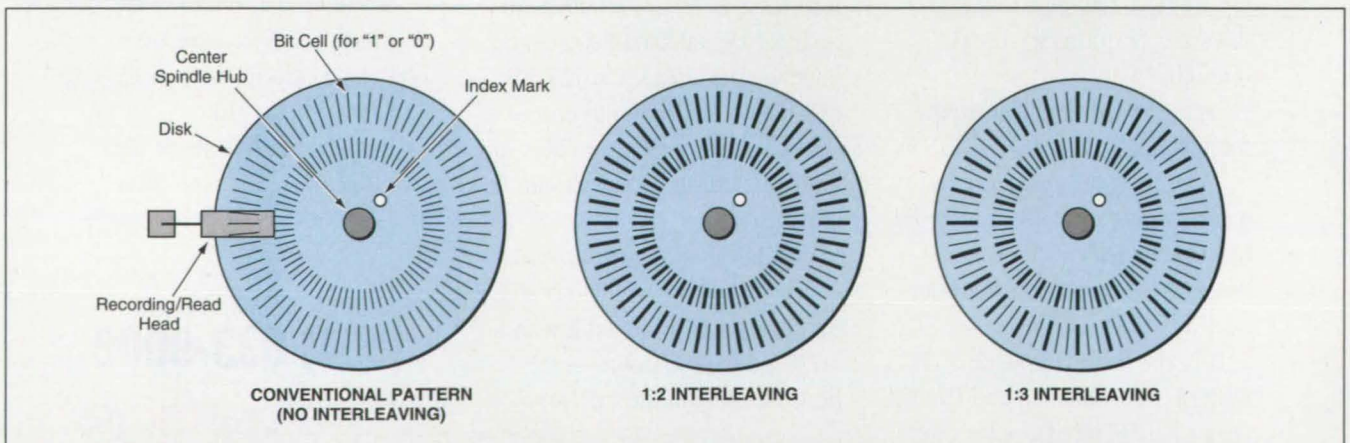

**Data Would Be Stored in Interleaved Patterns** instead of the conventional noninterleaved pattern of sequential bits in adjacent cells. For the sake of clarity, only two tracks are shown, with the numbers of bit cells greatly reduced. In the interleaved patterns, each bit cell shown in bold is logically (sequentially) related to the next bit cell shown in bold.

# MSC and Silicon Graphics:

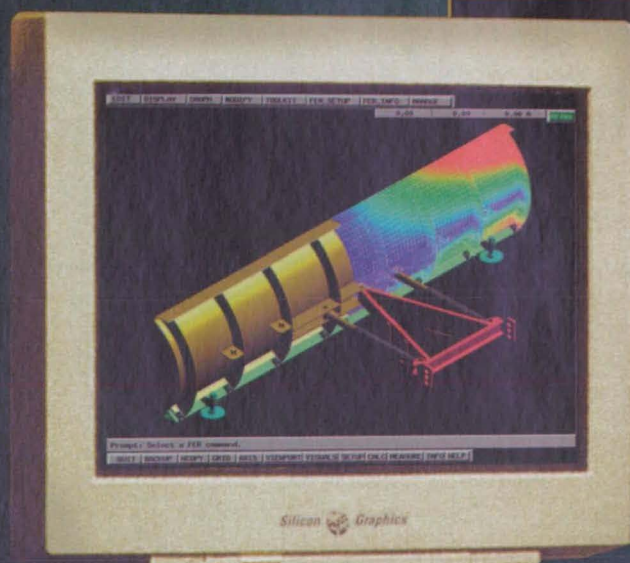

## The Powers That Be.

### Together, Giving You The Power To Do.

When MSC and Silicon Graphics collaborate, the results are impressive: Blistering analysis speed. Superior graphics. Unmatched reliability. Smooth interaction with geometry and results. And greatly compressed design cycles.

Now analysts and design engineers can extract the ultimate MSC/NASTRAN performance from highly advanced Silicon Graphics® computers. MSC/NASTRAN has been extensively customized for superior, seamless performance from the expandable POWER Indigo2™ workstation up to the POWER CHALLENGE™ parallel processing server. As a result, the most complex stress, vibration, and heat transfer problems can now be solved in a fraction of the time.

MSC and Silicon Graphics. Joining forces to give you the power to do the undoable. For MSC information, call 800-642-7437, ext. 2500 or visit MSC's website at <http://www.macsch.com>. For more information about Silicon Graphics products, call 800-800-7441, or visit the Silicon Graphics website at <http://www.sgi.com>.



**SiliconGraphics**  
Computer Systems



The  
**MacNeal-Schwendler**  
Corporation

Silicon Graphics and the Silicon Graphics logo are registered trademarks, and POWER Indigo2 and POWER CHALLENGE are trademarks, of Silicon Graphics, Inc.

Snow plow image courtesy of FISHER Engineering. FISHER® is a registered trademark of Douglas Dynamics L.L.C.

For More Information Write In No. 561

disks are also increased. With increases in both bit density and disk speed, the rates at which data flow to and from disks increase. These data rates can become too high for cost-effective electronics to handle.

The proposed interleaved bit patterns would contain bits at high density, except

that the bits written in adjacent bit cells would belong to different sequences, and the bits in any given sequence would be written at intervals of  $N$  bit cells, where  $N$  denotes the depth of interleaving (see figure). Thus, the data in any given sequence would be read out at a rate equal to the readout rate for data stored

at  $1/N$  of the actual high density.

*This work was done by Romney R. Katti of Caltech for NASA's Jet Propulsion Laboratory. For further information, write in 91 on the TSP Request Card. NPO-19036*

## Hybrid-Circuit Module for dc-to-dc Power Converter

External components determine output voltage and provide dc isolation.

*NASA's Jet Propulsion Laboratory, Pasadena, California*

A small, high-efficiency hybrid module is designed to provide many of the functions of a dc-to-dc, dc-isolating power converter. This is a general-purpose module that contains all of the power- and signal-switching and analog signal-processing circuits that are likely to be needed. A circuit designer can add input and output filters, an isolation transformer, and a feedback compensation network (see figure) to obtain a complete dc-to-dc power converter.

A power converter that incorporates this module can operate at a maximum input voltage of 50 V. The output can be adjusted from 2.5 to 12 V. A 5-V (0- to 6-A) converter, switching at 50 kHz, with a 23- to 35-V input bus, has a maximum efficiency of 92 percent. Switching frequency can be adjusted up to several hundred kHz by the choice of  $R_T$  and  $C_T$ . Alternatively, the switching can be synchronized with an externally generated clock signal. If an isolation transformer with additional secondary windings is provided, multiple slave outputs can be obtained.

*This work was done by Vatche Vorperian, Robert Detwiler, and Dan Karmon of Caltech for NASA's Jet*

**Propulsion Laboratory.** For further information, write in 6 on the TSP Request Card. NPO-19411

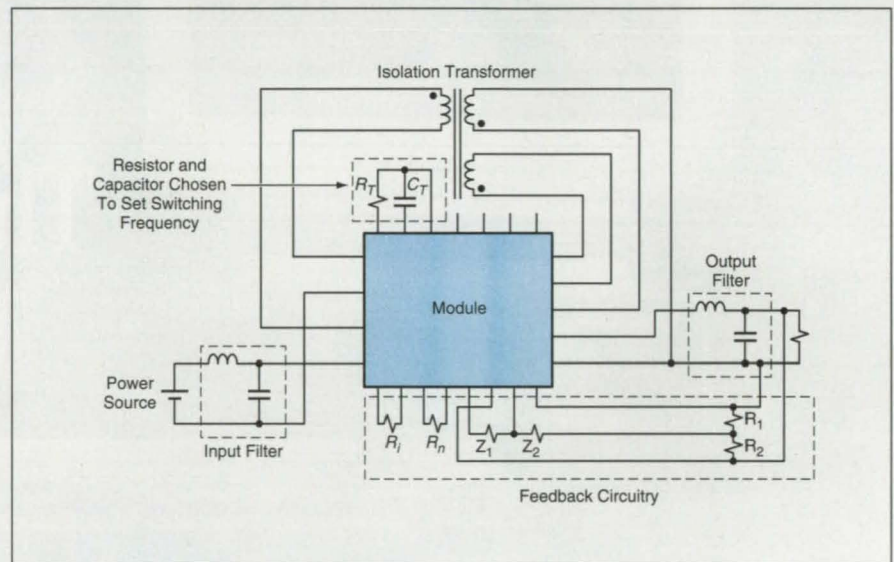

The **Power Hybrid Module** is a general-purpose power-switching module that provides flexibility in design and application. A complete dc-to-dc power converter can be constructed by adding the input/output filters and feedback circuitry to this module to suit the specific application.

## Thin-Ribbon Tapered Couplers for Dielectric Waveguides

Coupling efficiencies would exceed those of older tapered couplers.

*NASA's Jet Propulsion Laboratory, Pasadena, California*

Thin-ribbon tapered couplers have been proposed for launching electromagnetic waves into dielectric waveguides, which could include optical fibers. These couplers are intended especially for use with ribbon dielectric waveguides that are (1) designed for operation at millimeter or submillimeter wavelengths, (2) made of high-relative-permittivity, low-loss materials (e.g., TiO<sub>2</sub> with relative permittivity of 100 and loss tangent of  $2.5 \times 10^{-4}$ ), and (3) have thicknesses comparable to or less than the free-space design wavelengths.

These tapered couplers would offer coupling efficiencies greater than those of couplers that were designed according to the older concept of tapering the coupling end of a dielectric waveguide down to a single, sharp apex. For ribbon dielectric waveguides, this older concept is not practical when a material has a relative permittivity  $\gg 1$ . This is because in the case of such a high relative permittivity, the cross-sectional dimensions of the taper must be made very small to achieve good impedance matching between the dielectric wave-

guide and free space. This requirement, in turn, makes it difficult to handle and align the taper.

Moreover, the stability of those mode(s) of the electromagnetic field that adhere to the taper becomes questionable. In other words, it is difficult to excite a guided wave along the tapered section of a high-relative-permittivity dielectric waveguide, even when good impedance matching is present. It appears that the surface area of the tapered section is too small for efficient capture of the incident

# Connector Cleaner Plus

It's a Miller-Stephenson and Monsanto perfect match!

brings you state of the art total Connector treatment

Cleans, Protects and Extends Connector Life!



By combining the superior lubricating qualities of Monsanto's Polyphenyl Ether (PPE) with the dynamic cleaning power of our solvents, Miller-Stephenson has created Connector Cleaner Plus; a product line that provides the most advanced total treatment for connectors. Advantages:

- Cleans, lubricates and protects multi-pin connectors.
- Reduces insertion forces.
- Greatly increases mating cycles, (especially important where high pin counts are involved).
- Extends connector life by preventing corrosion and galling.
- Removes contaminants and oxides.
- Forms no residue, even at high temperatures.
- Is non-migrating - contains no silicones.
- Nonflammable.
- Available with a UV indicator.
- No interference in electrical continuity.
- NSN 6810-01-367-8095 (Aerosol)

TECHNICAL SUPPORT: 1-800-992-2424 (8-4 Eastern Time).  
IN CANADA 1-800-323-4621 (8-4 Eastern Time).

milller-stephenson chemical company, inc.

**CALIFORNIA**  
12261 Foothill Boulevard  
Sylmar, California 91342  
818 896-4714

**ILLINOIS**  
6348 Oakton Street  
Morton Grove, Illinois 60053  
708 966-2022

**CONNECTICUT**  
George Washington Highway  
Danbury, Connecticut 06810  
203 743-4447

**CANADA**  
514 Carlingview Drive  
Rexdale, Ontario M9W 5R3  
416 675-3204

COMPLETE COUPON BELOW

PLEASE SEND



AEROSOL

SAMPLE



BULK SAMPLE

16oz.

8oz. 183N

Enclose \$10.00 for each sample. Mail to:



**milller-stephenson chemical co., inc.**  
George Washington Highway  
Danbury, Connecticut 06810 U.S.A.

INTENDED USE \_\_\_\_\_

NAME \_\_\_\_\_

DEPT./TITLE \_\_\_\_\_

COMPANY \_\_\_\_\_

ADDRESS \_\_\_\_\_

1107-2P/5

NTB/1Q

For More Information Write in No. 406

wave and transformation of the incident wave into a guided wave.

A thin-ribbon tapered coupler according to the present concept would be formed by forming a dielectric waveguide into a wide, thin, flattened section. Typically, waves would be launched into the dielectric waveguide from a metal waveguide with an end taper fitted to that of the dielectric waveguide. Optionally, the transition region could be extended by use of a comblike structure at the end (see figure). The dimensions of the dielectric waveguide and its coupling taper would be chosen to obtain the required impedance match and coupling efficiency; for this purpose, the propagation of waves and conversion modes would be analyzed by use of conventional waveguide mode equations with some simplifying assumptions.

Because of its large surface area, the dielectric taper could easily be supported mechanically without noticeable perturbation of the electromagnetic field. In comparison with a narrow taper of the older type, this taper would feature a much larger surface area, which would enable the guided surface wave to attach itself better to the waveguide, thereby increasing the launching efficiency.

This work was done by Tom Y. Otoshi, Fred I. Shimabukuro, and Cavour Yeh of Caltech for NASA's Jet

Propulsion Laboratory. For further information, write in 7 on the TSP Request Card. NPO-19296

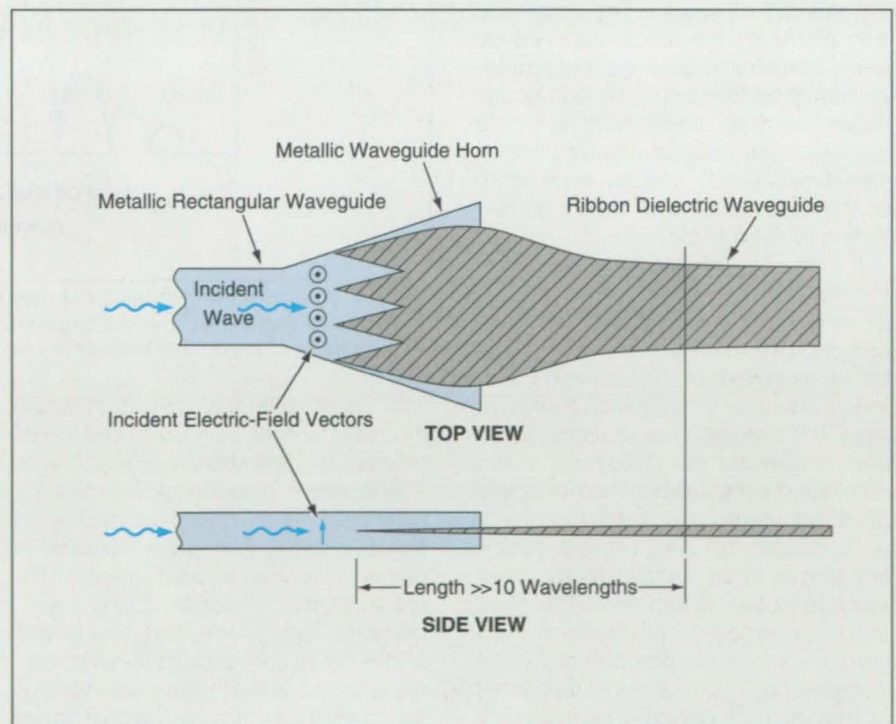

The End of a Dielectric Waveguide Would Be Tapered to a wide, thin, flattened section to enhance coupling of electromagnetic waves from a metal waveguide (or from free space).



## Automatic Phase-Compensation Modules for Antennas

The modules would be used to correct for distortions in antenna reflectors.

*Lewis Research Center, Cleveland, Ohio*

Automatic amplitude-controlling and phase-shifting modules are being developed in order to adaptively compensate for distortions in the reflectors of microwave communication antennas. An antenna of the type in question would include a phased array of radiating antenna elements in the focal plane of an off-axis paraboloidal or similar reflector. A module of the type in question would lie on the path of the radio-frequency feed between each antenna element and the radio-frequency transmitting/receiving equipment (see Figure 1).

The objective of the compensation scheme is to make the transmitted far field closely approximate a plane wave, despite deviations of the reflector from the ideal paraboloidal or other design figure. First, the antenna would be made to receive a plane wave by aiming it at a distant radio source of the desired frequency. The amplitude and phase of the signal received by each element would be measured. Inasmuch as this amplitude and phase would be that associated with the actual received electromagnetic field, it would necessarily include a measure of the electromagnetic effects of distortion in the reflector.

A control computer associated with the phased array would use the phases and amplitudes measured during reception to compute the excitations to be supplied to the antenna elements during subsequent transmission. The computed excitations would compensate for the distortions in the reflector on the basis of the principle of direct conjugate field matching. According to this principle, the excitation that must be supplied to each element to obtain a transmitted far field that approximates a plane wave has a complex amplitude proportional to the complex conjugate of signal measured at that element during reception.

Each automatic amplitude-controlling and phase-shifting module would include an automatic phase-conjuga-

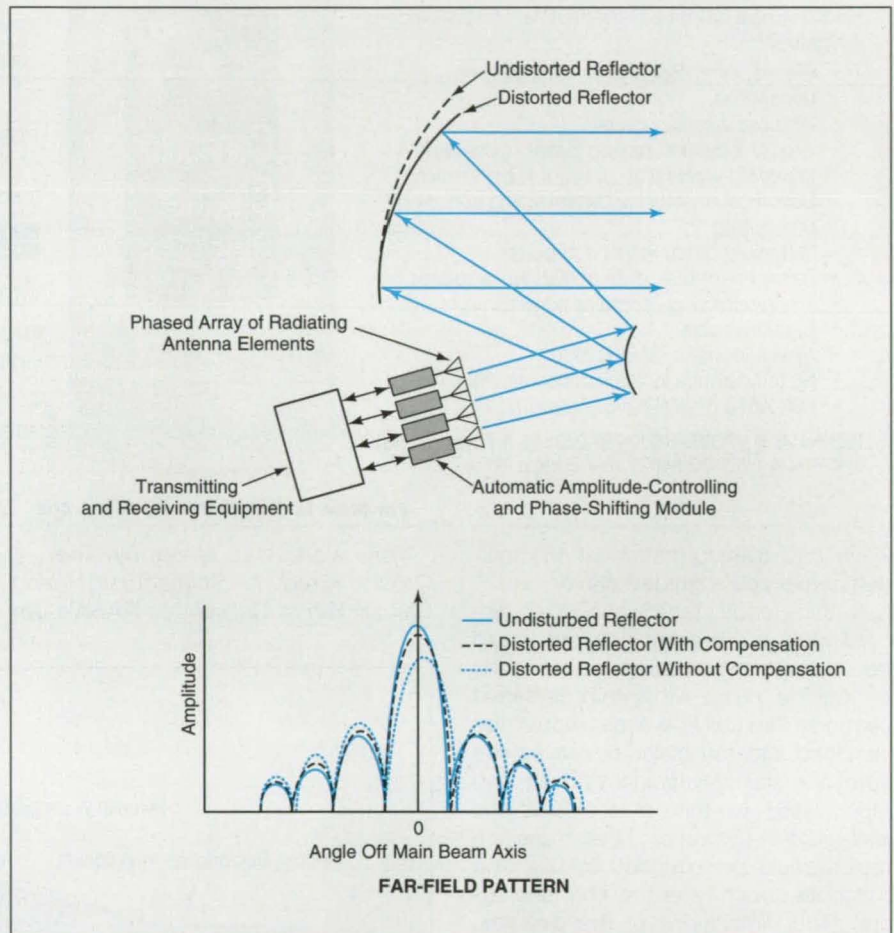

Figure 1. **Automatic Amplitude-Controlling and Phase-Shifting Modules** in the phased array of radiating elements would compensate for distortions in the reflector to obtain an approximation of the desired far radiation field.

tion submodule that would measure the amplitude and phase of the signal received by its antenna element. Figure 2 is a block diagram of a prototype submodule that has been built and tested. The submodule includes a phase shifter that is used to adjust the phase of the excitation during transmission. During reception, the phase shift is set to zero and the received signal is mixed with a local-oscillator signal to shift the received signal to an intermediate frequency (IF). The IF signal is amplified, then digitized at a sampling rate equal to a multiple of the IF.

A microcomputer multiplies the digital IF received-signal samples by digital samples of in-phase and quadrature versions of a synchronizing IF sinusoid that is supplied in common to all the modules. The microcomputer performs discrete-product integrations by summing the products of these multiplications. The results of the discrete-product integrations are an in-phase component ( $p_i$ ) and a quadrature component ( $p_q$ ) proportional to those of the received signal. The

*(continued on page 50)*



## Low-cost piezo-film accelerometers make life's ups, downs, and sudden turns manageable.



*Off-the-shelf piezo-film accelerometers: our low-cost, high-performance packages are ready to design in, and available in volume.*

The big news in sensors: our lineup of low-cost, high-performance accelerometers based on piezoelectric polymer technology. The good news for you: a big choice of off-the-shelf, ready-to-go sensors—in full production, with immediate availability.

Take a look at our very affordable single-axis versions for big-volume applications as diverse as car alarms, vibration/shipping-damage sensing, even musical instrument pickups. Small and lightweight. Buffered, low-impedance output. Wide frequency response and dynamite dynamic range.

If life keeps adding new twists, turn to our low-cost multi-axis types. Very small, very light, these true “smart sensors” are the smart choice for appliance, automotive, and security applications,

and are already in use by the millions for disk drive shock sensing. Digital and analog output. Integrated, programmable electronics for filtering, amplification, and trigger-level control.

For needs beyond OEM, take a look at our instrumentation-grade, low-noise, high-output types, with fully integrated electronics (no charge amplifier or power supply worries). Very competitively priced. Ideal for demanding applications from machine health to modal analysis—or just about any spot you need a top-performance accelerometer.

We'd like to let you check out all the specs for yourself, and to help you get a handle on at least a few of life's ups and downs. Just call.

AMP is a trademark.

For more information, call 610-666-3500 (fax 610-666-3509). AMP, Harrisburg PA 17105-3608. In Canada, call 905-470-4425.

For More Information Write In No. 517

# AMP

# EVERYTHING ABOUT PARTS HAS EXCEPT OUR C

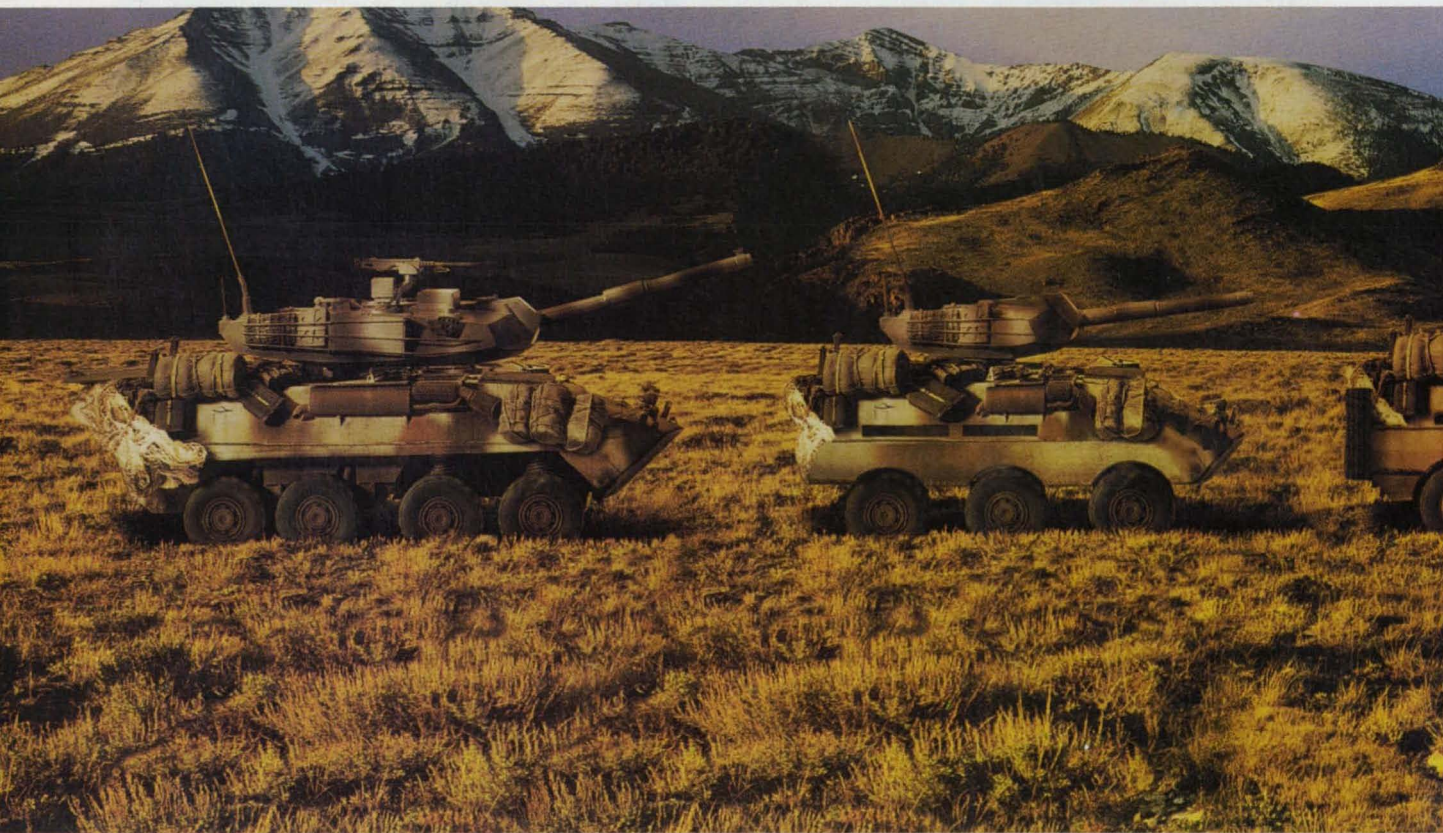

© 1996 Xilinx, Inc., 2100 Logic Drive, San Jose, CA 95124. Europe, 44 (932) 549401; Japan, 81 (3) 2579191; Asia, 852 (3) 721-0900.

The need for high-reliability parts hasn't gone away.

But you'd never know it by the number of suppliers who have.

Fortunately for a lot of companies in defense electronics, aerospace, avionics — even in the auto industry — the leading supplier of

programmable logic isn't going anywhere.

After all, applications like electronic surveillance, radar and passenger airplanes require a higher caliber of parts than toaster ovens.

And as we

all know, the need for these applications is going to be around

for a long, long time. That's why Xilinx is expanding its support.

We're adapting technologies and developing products to meet ever-changing demands in the market.

Currently, we're delivering the highest-performance,

Current Xilinx Hi-Rel FPGA Products	
Product	Features
XC4003A XC4006 XC4010 XC4013	<ul style="list-style-type: none"> <li>• Highest density/feature-rich family</li> <li>• 3000-13000 gates (current)</li> <li>• Up to 192 user-definable I/Os (current)</li> <li>• Extensive system features include: on-chip user RAM, built in 1149.1 test, fast carry logic</li> </ul>
XC3142A XC3190A XC3195A	<ul style="list-style-type: none"> <li>• Highest performance family</li> <li>• 2500-7500 gates</li> <li>• Up to 144 user-definable I/Os</li> </ul>
XC3020 XC3042 XC3090	<ul style="list-style-type: none"> <li>• 1000-6000 gates</li> <li>• Up to 144 user-definable I/Os</li> </ul>
XC2018	<ul style="list-style-type: none"> <li>• 1000-1500 gates</li> <li>• Up to 74 user-definable I/Os</li> </ul>

*How's this for commitment? Xilinx offers the widest selection of Hi-Rel parts in the business. No ifs, ands or maybes.*

# T HIGH RELIABILITY CHANGED, OMMITMENT.



Xilinx is a registered trademark, all XC designations are trademarks, and The Programmable Logic Company is a service mark of Xilinx, Inc. All other trademarks or registered trademarks are the property of their respective holders.

most reliable PLDs that ever met a circuit board. With densities of 13,000 gates today, 25,000 next year and plenty more down the road.

Which means, you won't have any shortage of Hi-Rel parts to choose from.

What's more, Xilinx

gives you the widest selection of speed, packages and temperature grade options, plus a powerful set of design tools with features that give you more flexibility, routing and gate utilization than ever before.

In other words, if you need options,

you need Xilinx.

And if anybody says there's no future in Hi-Rel, don't get mad.

Just tell 'em to take their chips and go build some toaster ovens.

For more information about the widest selection of Hi-Rel parts in the business, call 1-800-231-3386.

Or check out our home page at <http://www.xilinx.com> And Xilinx?

If this ad is any indication, we're here for the long haul.

No matter where that happens to take us.

 **XILINX**<sup>®</sup>

The Programmable Logic Company.™

phase ( $\beta$ ) of the received signal is then computed from  $\beta = \tan^{-1}(\rho_o/\rho_i)$  and a number ( $l$ ) proportional to the amplitude of the received signal is computed from  $l = (\rho_o^2 + \rho_i^2)^{1/2}$ . Applying the principle of direct conjugate field matching, the amplitude of the signal supplied to the radiating element during subsequent transmission would be adjusted to be proportional to  $l$ , while the phase of the signal would be shifted by the amount of  $-\beta$ .

This work was done by John D. Terry and Richard R. Kunath, Jr., of **Lewis Research Center**. For further information, write in 86 on the TSP Request Card. LEW-15719

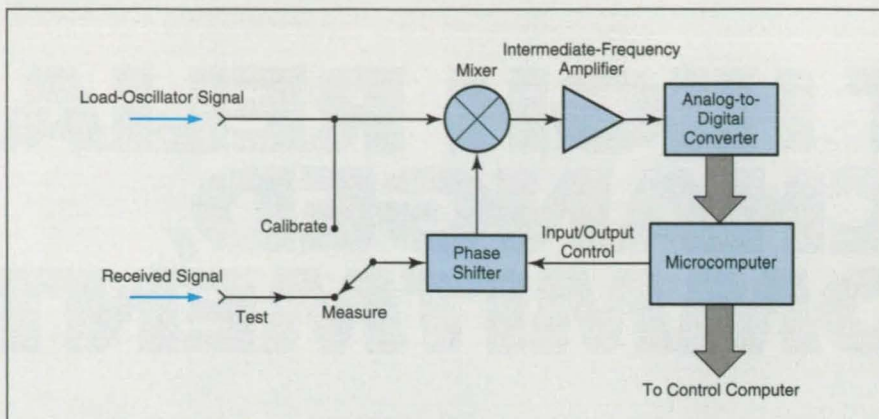

Figure 2. This **Automatic Phase-Conjugation Submodule** is a prototype of identical units that would be incorporated into the automatic amplitude-controlling and phase-shifting modules of Figure 1.

## Measuring Motor-Shaft Clearance and Wobble During Operation

The rate of rotation can also be measured.

Goddard Space Flight Center, Greenbelt, Maryland

The figure illustrates a system for real-time measurement of the distance and small variations of the distance between two mechanical components that are designed to be maintained at a precise, fixed distance. In particular, the system is intended for use in measuring the lateral clearance and variations in the lateral clearance (that is, wobble) of a motor shaft relative to the motor housing while the shaft is turning. Measurement of wobble provides an early indication of wear in the motor bearings; wobble that exceeds a maximum allowable level can serve as cause for replacement of the bearings. In a systematic program for maintenance of critical machinery, it is more cost-efficient to replace bearings for cause than it is to wait for the bearings to fail or to replace bearings on a regular schedule without cause.

In this system, the lateral position of the shaft is measured by use of any of a variety of noncontact electromagnetic or capacitive proximity sensors. The sensor is mounted in a fixed position in the motor housing with its sensing tip near the lateral surface of the shaft. The surface of the shaft must be electrically conductive. If it is not conductive, then a circumferential strip of conductive or semiconductive material can be applied to the surface to provide the necessary conductivity.

Preferably, the sensor is a commercial, pencil-shaped eddy-current liftoff probe. As its name suggests, an eddy-current liftoff probe is designed to exploit the eddy-current liftoff effect, which is a

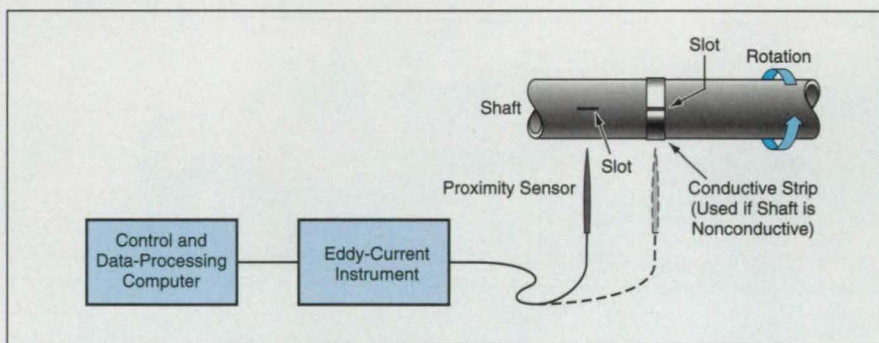

A **Noncontact Proximity Sensor** — preferably an eddy-current liftoff probe — provides a real-time indication of the wobble of a motor shaft in its bearings.

variation in the output voltage or impedance reading(s) of the probe with distance from an electrically conductive surface like that of the shaft. The tip of such a probe can have a diameter as small as 0.04 in. (1 mm), making it possible to fit the probe into a typical confined space inside a machine.

The system includes an eddy-current instrument, which contains electronic circuits that excite the probe and process the probe reading(s) into digital data. A personal computer that controls the system receives these data and processes them into distance measurements via a calibration algorithm. Measurements obtained in this way can be as accurate as 0.0004 in. (0.01 mm). The measurements can be displayed in real time in digital and/or graphical format. Optionally, the data can be processed further to analyze wobble or display indications of wobble in alternative forms or formats.

A slot or slots can be machined into the shaft or in the conductive or semiconductive strip on the shaft at one or more points on the circumference to provide an eddy-current discontinuity that can be used to measure the rotation of the shaft. By processing the eddy-current readings to extract and count the number of passages of the discontinuity during an observation interval, one obtains a number proportional to the speed of rotation.

This work was done by Engmin James Chern of **Goddard Space Flight Center**. For further information, write in 12 on the TSP Request Card.

This invention is owned by NASA, and a patent application has been filed. Inquiries concerning nonexclusive or exclusive license for its commercial development should be addressed to the Patent Counsel, Goddard Space Flight Center; (301) 286-7351. Refer to GSC-13570.

Space...The Final Frontier

# SUPER-SLIM PHOTOELECTRIC SENSORS

SUNX EX-10 SERIES

## DIMENSIONS

Height .....14.5 mm  
Length .....13 mm  
Depth .....3.5 mm

## PERFORMANCE DATA

Response time .....Maximum 0.5 ms  
Repeatability .....Maximum 0.05 mm  
Minimum sensing object .....0.1 mm  
Sensing range (Through beam) ..Up to 500 mm  
Sensing range (Diffuse beam) ....2 to 25 mm

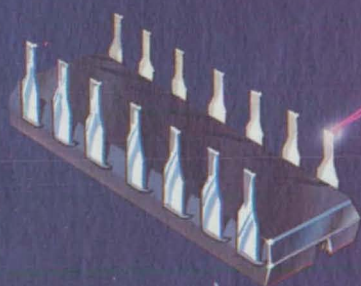

## Maximize Work Space With The Smallest Sensor On The Market

And in addition to saving space, the SUNX EX-10 series offers these benefits:

- Self-contained output allows the EX-10 to be connected directly to PLC to reduce component and space requirements.
- Front and side mounting options offer functional flexibility.
- Unaffected by background objects for greater reliability.
- Dark-object detection enhances performance.
- Waterproof IP67.



Pioneer in Sensor Systems

P.O. Box 65310 ■ 1207 Maple Street  
West Des Moines, IA 50265  
1-800-280-6933 ■ FAX (515)-225-0063

Call  
**1-800-280-6933**  
For Free EX-10 Information



## Phase-Conjugate Mirror Removes Wave-Front Distortions

Potential applications include multistage laser systems.

*Goddard Space Flight Center, Greenbelt, Maryland*

Phase-conjugate mirrors can remove distortions or aberrations from wave fronts in laser beams. Distortions of a laser beam can be caused, for example, by thermal effects in the atmosphere, inhomogeneities in crystals, and imperfect finishes on optical surfaces. A phase-conjugate mirror is essentially a bulk index-of-refraction diffraction grating formed by the interaction between a laser beam and a nonlinear optical medium in which the beam propagates. The beam reflected back along the direction of the incident laser beam is the phase conjugate of the input beam: therefore, as it travels back through the optical media that introduced the distortions into the incident laser beam, the distortions are removed.

Phase-conjugate mirrors could be used, for example, to prevent the degradation of a laser beam that is amplified to higher power in multiple laser stages, each of which can introduce aberrations into the beam. With the help of phase-conjugate mirrors, one can obtain high-power laser beams of diffraction-limited quality. One potential application is in NASA's proposed Geoscience Laser Ranging System for an Earth-observing satellite. This instrument will include compact, efficient solid-state lasers that will be required to produce pulses of 20 to 250 mJ lasting 0.1 to 50 ns. Multistage power amplification (with its concomitant potential for introducing aberrations) will be needed to produce such pulses.

Phase-conjugate mirrors can be implemented by use of stimulated Brillouin scattering or four-wave photorefractive mixing. (Four-wave mixing can also be used in laser communications and fiber optics.)

Stimulated Brillouin scattering can occur when an intense, pulsed, laser beam is focused into a gas or liquid. The beam interacts with the electrostrictive forces of the gas or liquid by locally heating a small volume of the material and changing its index of refraction. This interaction creates a density-and-index-of-refraction grating that travels through the material at the

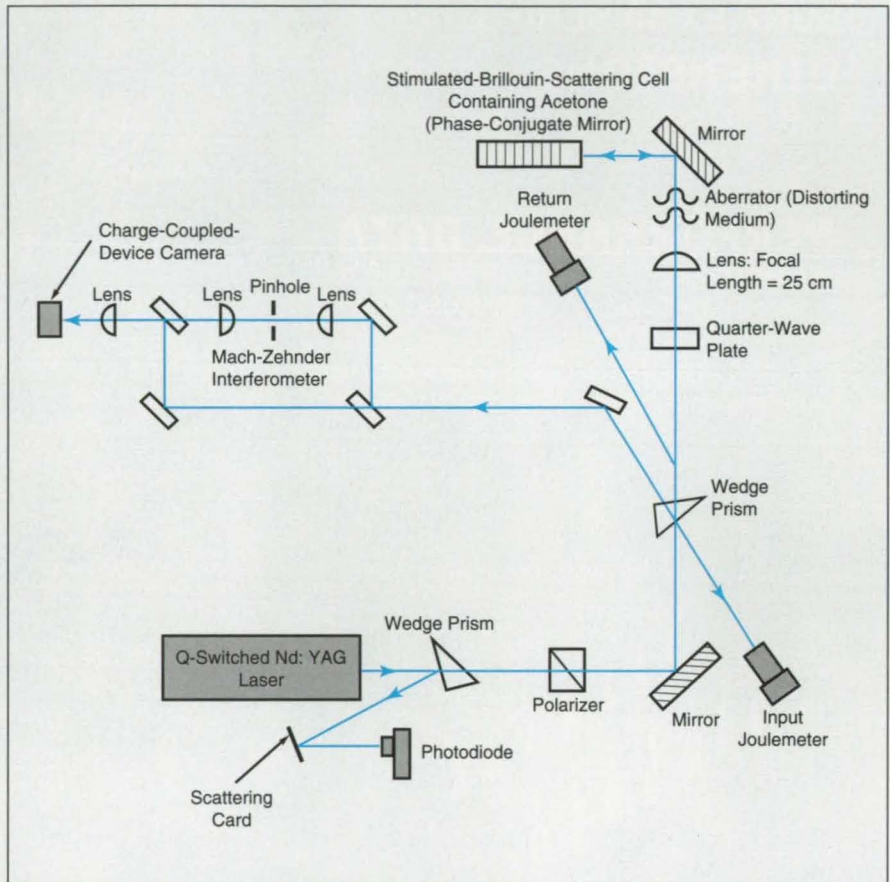

Figure 1. This **Laboratory Setup** can be used to demonstrate a phase-conjugate mirror.

speed of sound. The laser beam is Bragg-scattered off the moving grating, giving rise to a phase-conjugate backward-going (reflected) beam. The phase-conjugate/wave-front-reversal property and the associated ability to remove distortions can be used to compensate for aberrations in a double-pass amplifier by placing the phase-conjugate mirror behind the amplifier, where a conventional mirror would otherwise have been placed.

Figure 1 shows the layout of an experiment to demonstrate a stimulated-Brillouin-scattering phase-conjugate mirror for a pulsed laser system. A Q-switched neodymium:yttrium aluminum garnet (Nd:YAG) laser with a 60-mJ output pulse of 20-ns duration was used as the laser source, and acetone as the

stimulated-Brillouin-scattering medium. Stimulated-Brillouin-scattering reflectivities as high as 60 percent were achieved. In the experiment, the cross-sectional area of a phase-conjugate beam produced by photorefractive four-wave mixing was compared with that of the return from a conventional mirror after passing back through the aberrating medium (see Figure 2). The phase-conjugate beam returned with a cross-sectional area equal to that of the unaberrated beam, but the cross section of the return from the conventional mirror was elongated.

Photorefractive four-wave mixing also gives rise to phase conjugation, but it involves the use of a continuous-wave (instead of pulsed) laser beam and a crystal (instead of a liquid or gas). The

# Count it! Measure it! Stat it! Fit it! Plot it! We've got it!

WINDOWS 95  
COMPATIBLE  
32 BIT VERSION



## Introducing the latest generation of the Jandel software family

Jandel Scientific Software announces a new generation of our product family—including many fast new 32-bit versions for Windows 95 and NT. Now, with OLE 2, you can use an Excel spreadsheet inside SigmaPlot and SigmaStat—or you can directly edit an embedded graph within Microsoft Word. Jandel Scientific—the leading family of scientific and engineering software since 1982.



### SigmaPlot FLEXIBLE SCIENTIFIC GRAPHING

From nonlinear regressions to multiple axes per graph, more than 75,000 researchers depend on award-winning SigmaPlot's flexibility and power to analyze and graph their technical data the way they need to.

Mac 625 Win 626

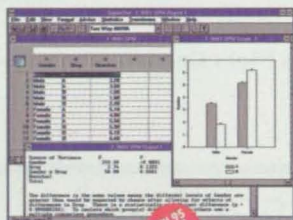

### SigmaStat ADVISORY STATISTICAL SOFTWARE

Advises on the test to use, checks for violations in underlying assumptions, runs the test, and explains the results. Handles messy data. Like having a professional statistical consultant at your fingertips.

Write In No. 627

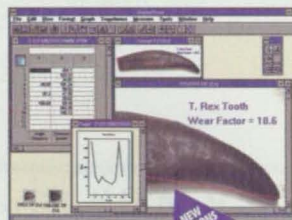

### SigmaScan IMAGE MEASUREMENT SigmaScan Pro IMAGE ANALYSIS

Easy, accurate and low-cost. SigmaScan for manual image measurements or SigmaScan Pro for automated measurements, counting, and image analysis.

Write In No. 628

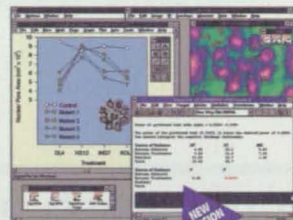

### SigmaSuite INTEGRATED GRAPHING, STATISTICS & IMAGE MEASUREMENT

The power of SigmaPlot, SigmaStat, and SigmaScan at a Suite price! Measure images, run statistics, and create graphs using SigmaLink for seamless data sharing in all three products.

Write In No. 629

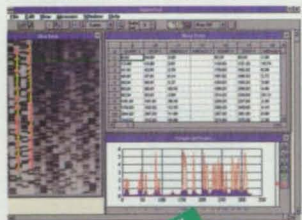

### SigmaGel GEL ANALYSIS SOFTWARE

Gel analysis—spot, lane, molecular weight, and DNA—on your lab or office PC. Works with inexpensive hand or desktop TWAIN-compatible scanners and imaging devices. Quality and speed previously available only in higher priced systems.

Write In No. 630

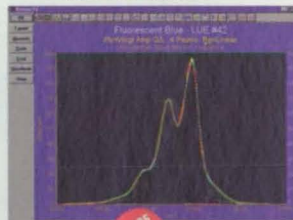

### PeakFit AUTOMATED NONLINEAR PEAK SEPARATION AND ANALYSIS

Automatically smoothes, finds, separates, fits, and analyzes Spectroscopic, Chromatographic, and Electrophoretic peaks. 91 built-in equations. Up to 15 UDFs. Advanced baseline subtraction and much more...

Write In No. 631

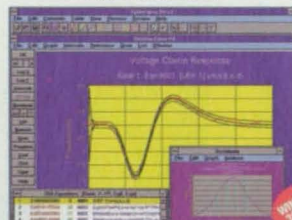

### TableCurve 2D & 3D AUTOMATED EQUATION DISCOVERY AND FITTING FOR EMPIRICAL DATA

2D fits 3,456 equations (XY)  
3D fits 453,697,365 (XYZ)  
They statistically rank each fit and allow the user to pick the best one, including up to 15 UDFs. All in seconds!

Write In No. 632

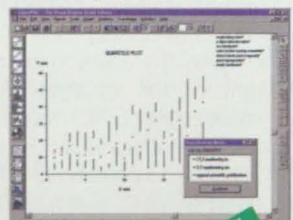

### Visual Display Graph Library

Dr. Edward Tufte designed The Visual Display Graph Library using the unique flexibility of new SigmaPlot. This new graph library includes: *The Visual Display of Quantitative Information* book, data density meter, style guidelines, fonts, and templates.

Write In No. 633

**TO GET IT CALL 1-800-4-JANDEL (1-800-452-6335)**

FOR MORE INFORMATION PLEASE CALL, FAX OR E-MAIL:  
Jandel Scientific: 2591 Kerner Blvd., San Rafael, CA 94901  
415-453-6700 Fax 415-453-7769 Internet: sales@jandel.com  
In Europe: Jandel Scientific, Schimmelbuschstrasse 25, 40699  
Erkrath, Germany 02104/9540 02104/95410 (FAX).

International Dealers: Australia 2 958 2688, Brazil 11 453 5588,  
Canada 519 767 1061, Chile 56 2 635 2422, Hong Kong 852 739 2001,  
India 40 31 3368, Israel 972 349 0823, Japan 3 3590 2311, 3 5689 8000,  
Korea 822 886 3983, Kuwait 965 242 1851, Malaysia 603 777 2597,  
Mexico 525 513 0399, South Africa, 12 660 2884, Taiwan 2 788 6777,  
2 705 1590 All company and/or product names are trademarks of their  
respective companies. ©1995 Jandel Corporation.

**Jandel**  
SCIENTIFIC SOFTWARE

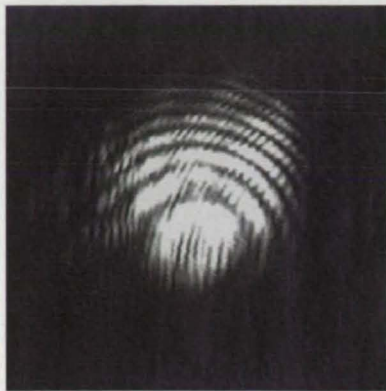

INTERFERENCE PATTERN FORMED FROM RETURN OF UNABERRATED BEAM



INTERFERENCE PATTERN FORMED FROM PHASE-CONJUGATE RETURN OF ABERRATED BEAM



INTERFERENCE PATTERN FORMED FROM RETURN OF ABERRATED BEAM VIA CONVENTIONAL MIRROR

Figure 2. These **Interference Patterns** were produced in the Mach-Zehnder interferometer of the apparatus shown in Figure 1. The effectiveness of the phase-conjugate mirror in removing most of the aberrational effects is apparent.

beam is focused into the crystal (which could be barium titanate for example) and interacts with the crystal via its photorefractive properties, giving rise to a grating. As in stimulated Brillouin scatter-

ing, the beam is then reflected off the grating and becomes the phase conjugate of the input beam.

This work was done by Bernard D. Seery of **Goddard Space Flight Center,**

Barbara J. K. Zukowski of Hughes STX Corp., and Babak Saif of EER Systems. No further documentation is available. GSC-13554

## Liquefaction of Coal With Surfactant and Disposable Catalyst

Fuels derived from coal may become more competitive with petroleum products. NASA's Jet Propulsion Laboratory, Pasadena, California

An improved coal-liquefaction process exploits the synergistic effects of a disposable iron oxide catalyst and a cheap anionic surfactant. The efficiency of conversion achieved in this process is significantly higher than the efficiencies obtained with the addition of either the surfactant or the catalyst alone. No costly pretreatment is necessary, and the increase in conversion is achieved under processing conditions milder than those used heretofore in liquefaction of coal. The quality of the distillates obtained after liquefaction in this process is expected to be superior to that of distillates obtained after liquefaction by older techniques. Further development of this process may eventually reduce the costs of fuels derived from coal enough to make such fuels competitive with petroleum products.

Fuels derived from coal have not been competitive with fuels derived from petroleum because of the high pressures and temperatures necessary to liquefy coal by older techniques, and because of the poor quality of the distillates. The state-of-the-art optimized process involves the use of supported

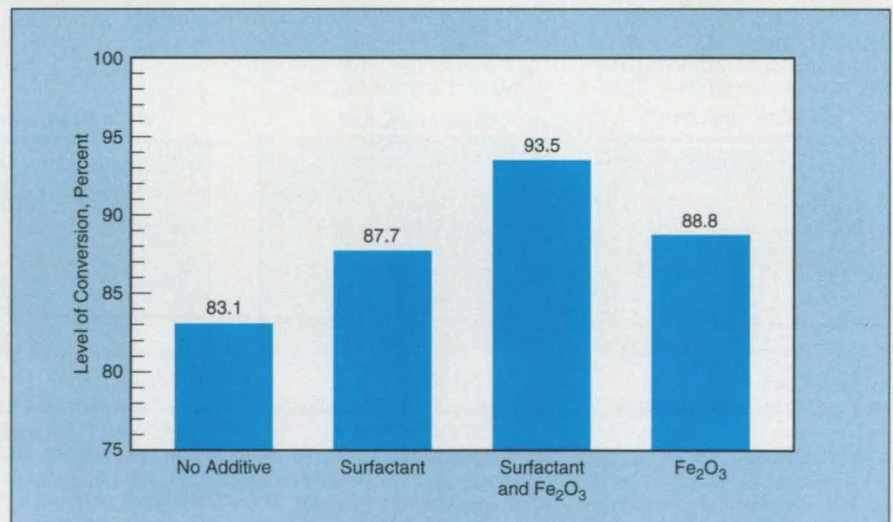

The **Level of Conversion** achieved by addition of both the surfactant and the catalyst is greater than that achieved by addition of either alone.

molybdenum and nickel/molybdenum-based catalysts in two-stage ebullating-bed reactors. The degree of conversion in this process lies in the range of 90 to 95 percent when the temperature in the reactors is 420 °C and the gauge pressure of hydrogen in the reactor is 2,200 psi (≈15 MPa).

Coal fragments tend to disperse poorly in nonpolar and mildly polar solvents and tend to agglomerate into aggregates of high molecular weight. In previous research directed toward breaking up these aggregates, the addition of surfactants was investigated. Conversion levels of about 90 percent were



obtained when sodium lignosulfonate was added as a surfactant in a noncatalytic process.

In experiments that led to the improved process, specimens of coal were treated, variously, by addition of either (a) no additive, baseline case, (b) 1 percent of surfactant, (c) 1 weight percent of finely ground (particle size less than 20  $\mu\text{m}$ ) iron oxide powder as the catalyst, or (d) both 1 percent iron oxide and 1 percent

surfactant. The process was run at a temperature of 375  $^{\circ}\text{C}$ , with hydrogen at a gauge pressure of 1,800 psi ( $\approx 12$  MPa) for 1 hour. The levels of conversion achieved in cases (a), (b), (c), and (d) were 83.1, 87.7, 88.8, and 93.5 percent, respectively (see figure): This result indicates that addition of the iron oxide and surfactant can exert a positive synergistic effect on the liquefaction of coal. It has been conjectured that the surfac-

tant improves the hydrodynamics in the reactor, enabling the coal to come into more intimate contact with the catalyst.

*This work was done by Gregory S. Hickey and Pramod K. Sharma of Caltech for NASA's Jet Propulsion Laboratory. For further information, write in 80 on the TSP Request Card. NPO-19221*

## Computing Noise Temperature in a Beam Waveguide

Contributions from spillover are treated semiempirically.

NASA's Jet Propulsion Laboratory, Pasadena, California

A method of computing the noise temperature in a beam waveguide system (see figure) involves both theoretical and experimental elements. The method circumvents the problem of computing the noise temperature exactly from first principles: in the case of a typical practical system, the noise-temperature problem is so complex and difficult that an exact solution is impossible.

In this method, the noise temperature,  $T_{\text{BWG}}$ , is expressed as a sum of two parts:  $T_{\text{BWG}} = T_m + T_{\text{spill}}$ . Similarly, the total beam power,  $P_{\text{BWG}}$ , is expressed as  $P_{\text{BWG}} = P_m + P_{\text{spill}}$ .  $P_m$  is that part of the beam power that is always confined inside all mirrors.  $P_{\text{spill}}$  is the sum of each mirror that is mainly dissipated and converted to noise by multiple reflections and absorption in the shroud and behind the mirrors.  $T_m$  and  $T_{\text{spill}}$  are the contributions

to  $T_{\text{BWG}}$  associated with  $P_m$  and  $P_{\text{spill}}$ , respectively.  $T_m$  is given by  $T_m = \alpha_m \beta$ , where  $\alpha_m = P_m/P_{\text{BWG}}$  and  $\beta$  is a function of the frequency of the beam and the temperature and electrical resistivity of the mirrors. The value of  $\alpha_m$  and  $\beta$  can be computed accurately. However, because of the complexity of the multiple reflections and absorptions  $T_{\text{spill}}$  cannot be computed analytically. The technique used to compute  $T_{\text{spill}}$  will be described next. The noise temperature  $T_{\text{spill}}$  is given in a form  $T_{\text{spill}} = \alpha_{\text{spill}} T_0$  where  $\alpha_{\text{spill}} = P_{\text{spill}}/P_{\text{BWG}}$  and  $T_0$  is an effective noise temperature (in Kelvins) seen by

$P_{\text{spill}}$  and determined empirically.

Combining results from the foregoing equations, the total noise temperature can be expressed as  $T_{\text{BWG}} = \alpha_m \beta + \alpha_{\text{spill}} T_0$ . If at least one measurement of  $T_{\text{BWG}}$  in a beam waveguide of representative design is available, it can be used to compute  $T_0 = (T_{\text{BWG}} - \alpha_m \beta) / \alpha_{\text{spill}}$ . Thereafter, it is not necessary to repeat measurements of  $T_{\text{BWG}}$ . Instead, one can use the computed value of  $T_0$ , under the assumption that it is applicable to any beam waveguide of similar design, including a shroud structure with nearly the same electrical resistivity and frequency.

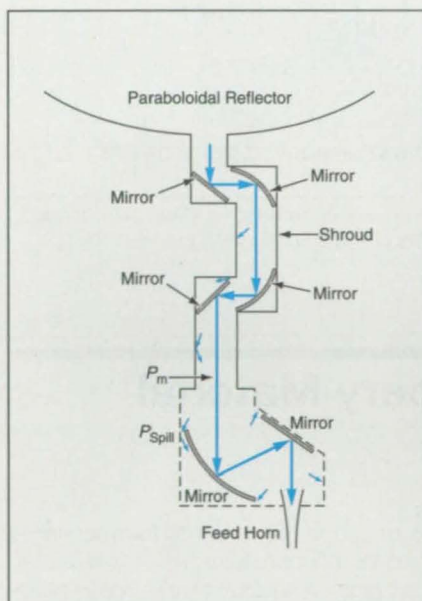

A Beam Waveguide System associated with a large paraboloidal antenna includes mirrors enclosed in a shroud. Contributions to noise are associated with the transmitted power,  $P_m$ , and the spillover power,  $P_{\text{spill}}$ .

## RevPoint 3D Systems

### Interactive 3D design

Affordable, real time 3D input is available right now. SoftWorld International has taken the best products from Europe and the United States and combined them in an affordable, intuitive package that you can use now.



The RevPoint 3D Systems is a complete package that provides real time 3D input with all of the software you'll need for Reverse Engineering, Rapid Prototyping, 3D Modelling, or Design. As simply as you would use a tablet stylus, place the 3D probe on the surface of an existing part and you are now working in 3D.

- Hand held Flexibility
- Portable
- Stable, interactive input
- 0.005"/0,1 mm. resolution, 0.012"/0,3 mm. accuracy
- Low cost
- Easy to use real time input and commands

You'll be surprised at how affordable the RevPoint 3D System is. Call today for a free brochure and price list.

**SoftWorld**  
INTERNATIONAL

The 3 Dimensional Solutions Company  
133 admiral Street, Bridgeport, CT. 06601,  
USA, Tel.: (203) 367-7789 Fax.: (203) 367-8331  
European office: SoftWorld Aps.  
Tel.: 45 45 41 00 77 Fax.: 45 42 42 03 88

In the case of a long and/or complicated beam waveguide, more accurate results can be obtained by dividing  $\alpha_{\text{spill}}$  into  $\alpha_1$  and  $\alpha_2$  and the corresponding noise-temperature coefficients into  $T_1$

and  $T_2$ . Then  $T_{\text{spill}} = \alpha_1 T_1 + \alpha_2 T_2$ , the 1 and 2 components representing contributions from different parts of the waveguide structure.

This work was done by Watt Verut-

tipong and Manuel M. Franco of Caltech for NASA's Jet Propulsion Laboratory. For further information, write in 88 on the TSP Request Card. NPO-19119

## Water-Repellency Probe

A simple measurement reveals the presence or absence of waterproofing material in a blanket.

Lyndon B. Johnson Space Center, Houston, Texas

An instrument yielding the presence or absence of waterproofing agent at any given depth in a blanket has been developed. In its original application, the blankets in question were part of the space shuttle thermal protection system. The instrument was utilized to determine the extent of waterproofing "burnout" due to re-entry heating and adverse environment exposure. Areas which do not have substantial waterproofing removal become candidates for elimination of this process in the following flow.

The instrument (see figure) includes two needles which are electrically insu-

lated except for the very tip. The needles are connected to an ohmmeter to measure electrical conductance between the two probes. A small amount of deionized water is applied to the surface of the blanket. The water creates an electrically conductive media in the non-waterproofed region of the blanket. The needles are slowly removed from the surface of the blanket at a consistent rate. When the needles penetrate the boundary between the nonwaterproofed and waterproofed regions, the electrical conductivity between the probes decreases. When the conductivity decreases below a predetermined

setpoint, an alarm indicates the waterproofed region has been reached. A linear potentiometer provides a digital readout of the waterproofing burnout depth. The measurement is repeated at several points in each blanket from which an average burnout depth is obtained.

This work was done by Charles D. Rosen, Shirley M. Mitchell, Stanley R. Jolly, Richard G. Jackson, Scott T. Fleming, William J. Roberts, and Daniel R. Bell III of Rockwell International Corp. for Johnson Space Center. For further information, write in 22 on the TSP Request Card. MSC-22295

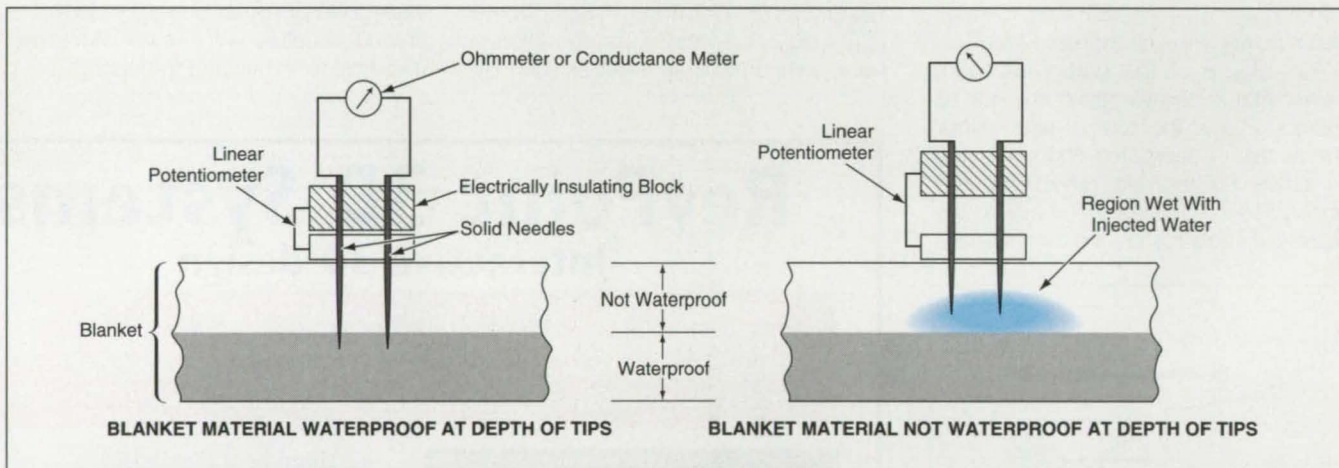

**Nonwaterproof Blanket Material Wicks Injected Water**, allowing the path between the tips of the needles to become electrically conductive. Waterproof blanket material does not wick injected water, preventing the formation of an electrically conductive path between the tips.

## Apparatus Tests Peeling of Bonded Rubbery Material

Growth of a blister under pressure is measured.

Marshall Space Flight Center, Alabama

The figure illustrates an instrumented hydraulic constrained blister-peel apparatus used to obtain data on the degree of bonding between a specimen of rubbery material and a rigid plate. (In the original application, the rigid plate is made of steel, and the specimen of rubbery material is a rectangular layered

slab of solid rocket propellant, liner, and insulator material bonded to the plate with an adhesive material.) The data from blister-peel tests can be used to determine critical fracture-energy release rates of such bonds.

In preparing the specimen and the rigid plate, a thin polytetrafluoroethylene disk

is placed at the center to form a central circular unbond from which the blister can grow. A liquid (typically, water) pressurized by a piston is admitted to the blister through a central hole in the rigid plate. Growth of the blister is constrained by a thick poly(methyl methacrylate) plate, which is transparent. A video cam-



Introducing Sun Ultra 1. A box so revolutionary,  
it allows you to think outside of it.

Forget incremental  
advancements. Forget  
compromises. In short,  
forget everyone else.

UltraComputing™ is here, and  
the only way you can get it is  
the Sun™ Ultra™ 1. The new workstation  
that converges all the best computing  
technology. A powerful 64-bit processor, real-time  
video and audio, imaging, 2D and 3D graphics, and the  
ability to run over 10,000 existing applications. It even offers  
networking that's 10 times faster than today's standards.  
And with supercomputing power on your desktop, you can  
collaborate in ways once thought impossible. Sun Ultra 1. You'll  
never look at computing the same way again. To learn more,  
call 1-800-786-0785, Ext. 360. Or see us at <http://www.sun.com>



era observes the growth of the blister through the transparent plate.

Pressure in the water or other liquid is measured by a pressure transducer. The volume of liquid pumped into the blister is measured and controlled via displacement of the piston. The volumetric rate can also be measured and controlled; this is important because the blister-peel behavior of a specimen can be highly dependent on the rate of growth.

Time, pressure, and volume data are recorded digitally during the test. The size of the blister is computed from the digitized video image of the blister captured by a video frame grabber. From the foregoing data, a computer calculates the total energy released in each increment of growth of the blister.

*This work was done by Russell A. Crook and Robert Graham of Thiokol Corp. for Marshall Space Flight Center. For further information, write in 3 on the TSP Request Card. MFS-28878*

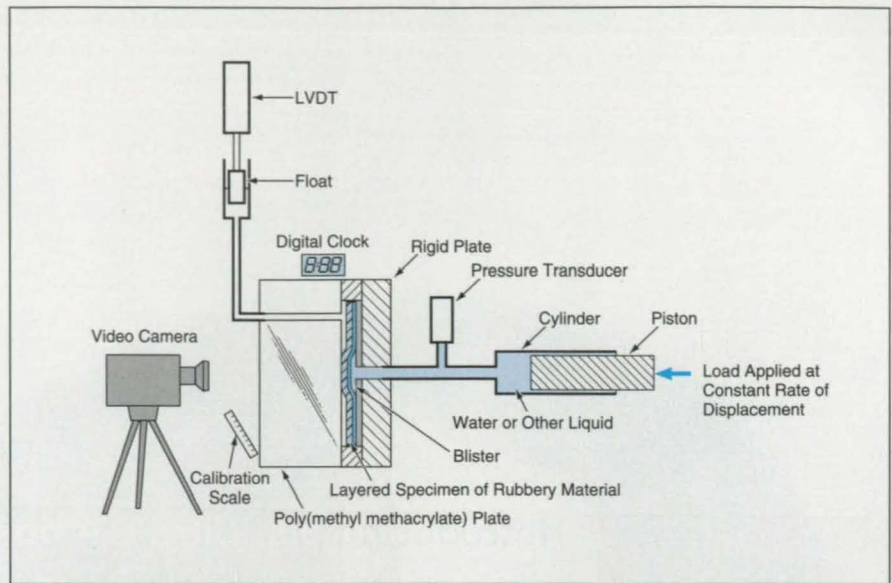

**Growth of a Blister** is tracked by a video camera, digital clock, pressure transducer, and a piston-displacement sensor. Cylinder pressure is controlled by a hydraulic actuator system. The linear variable-differential transformer (LVDT) and float provide a second, independent measure of change in blister volume that can be used as more precise volume feedback in a low-growth-rate test.

## Mass-Flow-Meter Leak-Testing System

This system provides more data, more accurately, in less time than did its predecessor.

*Marshall Space Flight Center, Alabama*

An improved leak-testing system incorporates a mass-flow meter as the primary sensor for measurement of the leakage rate. The system was developed to replace a leak-testing system based on measurement of pressure-decay rate after initial pressurization of a joint or vessel to be tested. In comparison with its predecessor, the improved system is easier to use and more reliable and it enables leak tests to be completed in 30 to 40 percent less time. In addition, it produces test data that are more plentiful, more accurate, and better suited to leak detection and diagnosis.

In the improved system, nitrogen (the testing gas) is supplied at regulated pressure to the vessel or joint to be tested, and the rate of flow of nitrogen through the vessel or joint is measured to obtain an indication of the size of the leak. The nitrogen is fed to the mass-flow meter and the test article via a tube bundle that is immersed in a tank of water for thermal stability (see figure). The tube bundle is standard tubing wrapped in a compact shape which acts as a reservoir, thereby facilitating regulation of the pressure.

The mass-flow meter contains a heated sensor tube through which the nitrogen flows. Temperature sensors in the heated tube produce readings indicative

of the rate at which the flowing nitrogen carries away heat from the tube. The rate of flow is related to the heat-transfer rate in a known way and is thus computed from these readings.

The leak-testing system is controlled by a computer in which expert-system software monitors sensor data in real time and alerts personnel to out-of-tolerance test conditions. Software controls pretest and posttest verification of integrity of the instrumentation, controls the test procedures, and monitors the configuration of hardware and the test parameters.

The system operates over a range of test conditions, including pressures from atmospheric to 1,000 psi (0.1 to 6.9

MPa), temperatures from 50 to 120 °F (10 to 49°C), and volumes from < 1 in.<sup>3</sup> to 22 in.<sup>3</sup> (<16 cm<sup>3</sup> to 361 cm<sup>3</sup>). The system is even sensitive enough to measure absorbed gas seeping from O-ring seals after test pressure has been released.

*This work was done by Eric B. Sorensen of Marshall Space Flight Center; Andre V. Polidori, Joe R. Heman, and Holland L. Dresser of Thiokol Corp.; and John Hellum of Cooper Oil Tool. For further information, write in 84 on the TSP Request Card.*

*Inquiries concerning rights for the commercial use of this invention should be addressed to the Patent Counsel, Marshall Space Flight Center; (205) 544-0021. Refer to MFS-31002.*

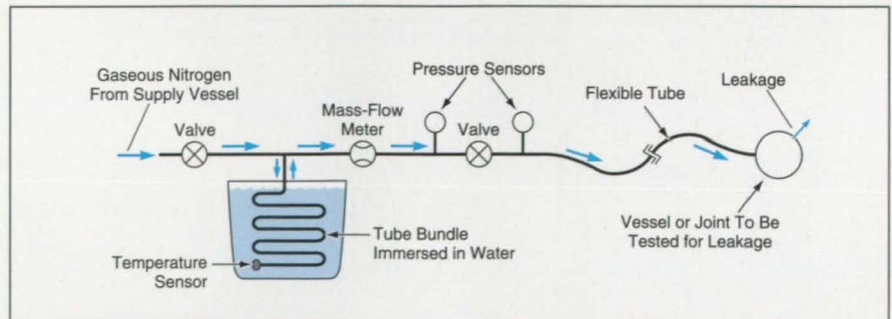

**Nitrogen Is Supplied at Regulated Pressure** to a sealed joint or vessel to be tested for leakage. Rate of flow indicated by the mass-flow meter serves as a measure of the size of the leak.

# FROM SUPERCOMPUTER TO PC

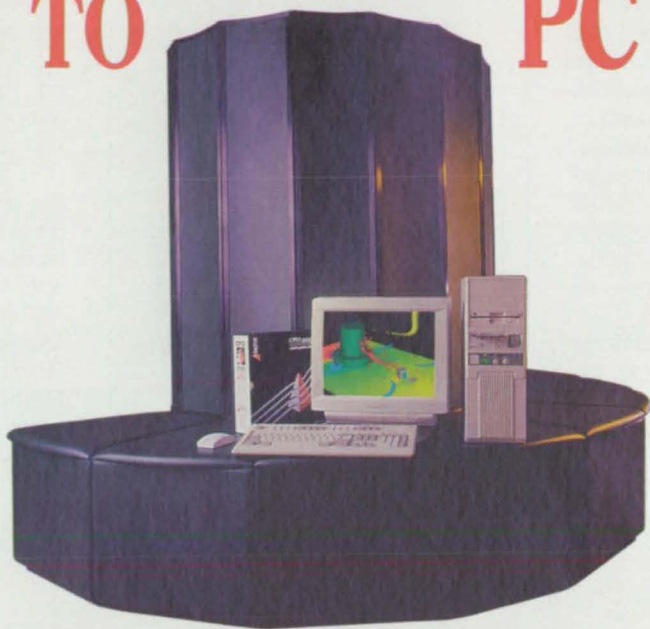

**Take the power of CFD into your own hands, the way you work, where you work — at your own desk!**

**Adaptive's newest version of CFD2000 can meet you on almost any platform: your PC, your workstation, or your supercomputer.**

Now, computer simulations of physical processes involving fluid dynamics coupled with heat transfer can be performed on your desktop. With CFD2000™, full 3D viscous Navier-Stokes flow — once achievable only via the supercomputer — is at your fingertips.

As a leader in computational fluid dynamics for over 20 years, Adaptive delivers software with advanced simulation capabilities,

## CFD SOLUTIONS *FLOW.*

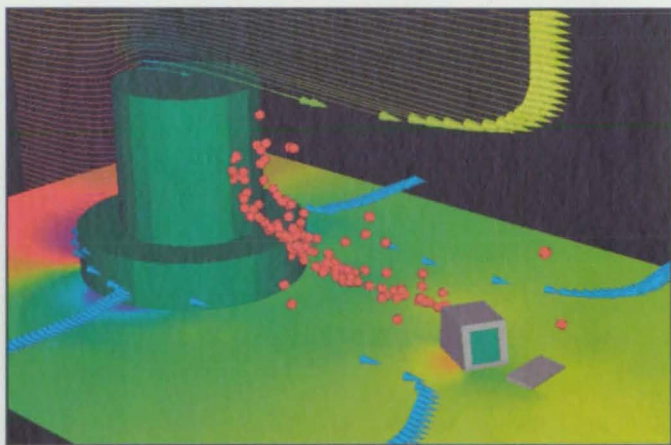

accomplished through continuous development and application. The results: CFD2000™.

Today's advances in computer memory and computer speed, in conjunction with CFD2000's™ revolutionary advances in numerical methods and user interface graphics tools, provide an enabling technology for designers and analysts who are addressing real problems in engineering mechanics.

Equip yourself with the tools that make engineering solutions flow. Call your Adaptive Technical Sales Engineer today to

find out how to solve your design challenges using computational fluid dynamics.



*"Adapt or Die."*

205 • 830 • 2620 4960 Corporate Drive, Suite 100-A • Huntsville, Alabama 35805, U S A • FAX 205 • 830 • 2628

For More Information Write In No. 524

# Oven Evaporates Isopropyl Alcohol Without Risk of Explosion

A convection oven can be made explosion-proof at relatively low cost.

*Marshall Space Flight Center, Alabama*

An ordinary convection oven with a capacity of 1 ft<sup>3</sup> (0.028 m<sup>3</sup>) has been modified for use in drying objects that have been washed in isopropyl alcohol. The oven can probably also be used to evaporate other flammable solvents. The oven costs \$375; the materials used in modifying it to make it explosion-proof for evaporating isopropyl alcohol cost less than \$200. In contrast, a typical commercial explosion-proof oven costs at least \$10,000 (1993 prices).

The modifications were (see figure) the installation of equipment to purge the interior of the oven with gaseous nitrogen, the addition of a catch pan over the heater unit, and the installation of a safety flow switch and a door interlock. The safety flow switch keeps the oven turned off unless the nitrogen is flowing.

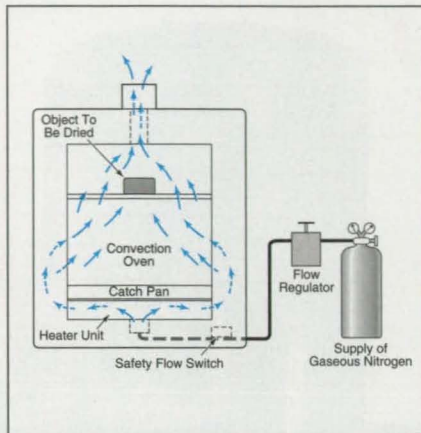

**Nitrogen-Purge Equipment** and safety interlocks are added to a convection oven to prevent explosive ignition of flammable solvent evaporating from the object to be dried.

An object to be dried is placed on the top shelf of the oven and the door is closed. The flow of nitrogen is turned on, then the oven is turned on. The temperature in the oven is monitored and is not allowed to exceed 250 °F (121 °C). Typically, the object is kept in the oven at the maximum temperature for at least 90 min. The oven is allowed to cool to 100 °F (38 °C) before the door is opened.

*This work was done by Gene E. Morgan and William S. Hoult of Rockwell International Corp. for Marshall Space Flight Center. For further information, write in 57 on the TSP Request Card. MFS-30050*

# Oxygen-Mass-Flow Calibration Cell

The flow of oxygen ions in a solid electrolyte would be proportional to the applied electric current.

*NASA's Jet Propulsion Laboratory, Pasadena, California*

A proposed calibration standard for the mass flow rate of oxygen would be based on the conduction of oxygen ions through a solid electrolyte membrane made of zirconia and heated to a temperature of 1,000 °C. An electric current applied through such a membrane in the presence of oxygen causes oxygen to be transported through the membrane at a rate proportional to the current, the proportionality being one oxygen molecule (O<sub>2</sub>) for every four electrons. An oxygen-mass-flow calibration cell based on this concept could be used to calibrate a variety of medical and scientific instruments that are required to operate with precise rates of flow of oxygen.

Older mass-flow-rate calibration standards are based, variously, on measurements of temperatures, pressures, and volumes, all of which affect each other. Errors in these measurements tend to be cumulative and to affect the final calibration mass flow rates. In contrast, the proposed standard would be unaffected by variations in temperature and pres-

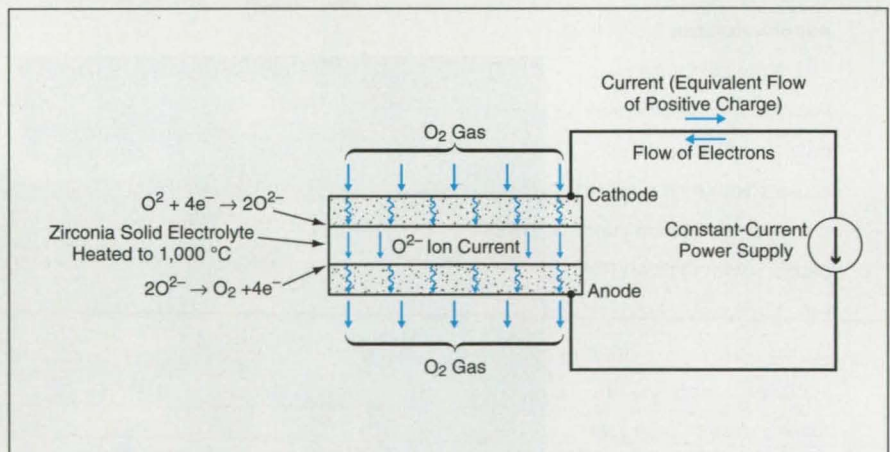

**Oxygen Ions Would Be Transported** through heated zirconia by the applied electric current. One oxygen molecule would be pumped through the zirconia membrane for every four electrons pushed around the circuit by the power supply.

sure, and would not require measurement of volume; electric current is the only parameter that would affect the rate of flow. Thus, by maintaining a constant, precise direct current, one could maintain a precise mass flow rate of oxygen; in principle, the flow could be main-

tained at the desired rate with an error much smaller than 1 percent.

*This work was done by Robert E. Martin of Caltech for NASA's Jet Propulsion Laboratory. For further information, write in 64 on the TSP Request Card. NPO-19327*



First, we invented optical fiber.  
Next, we built the devices.  
Later, we engineered the systems...  
Now, we're giving you more options to improve network  
performance and design.

# OFC<sup>®</sup>'96

## Optical Fiber Communication Conference and Exhibit

February 25 - March 1, 1996  
San Jose Convention Center  
San Jose, California

The backbone for the future of telecommunications.

For more information contact:

OFC '96

c/o Optical Society of America

2010 Massachusetts Avenue, NW Washington, DC 20036-1023

Call: 1-800-723-4OFC, 1-800-723-4632 or (202) 223-0920

Via e-mail: [ofcex@osa.org](mailto:ofcex@osa.org)

Sponsored by:

Optical Society of America

IEEE Communications Society

IEEE/Lasers and Electro-Optics Society



Join Fiberman in 1996



## Polyimides That Contain Pendent Siloxane Groups

The pendent siloxane groups impart properties that are desirable in some applications.

Langley Research Center, Hampton, Virginia

Polyimides that contain pendent siloxane groups (PISOXs) can be synthesized from polyimides that contain hydroxy groups (PIOHs) according to either of two alternative approaches. The addition of pendent siloxane groups to a polyimide decreases its dielectric constant, and decreases its absorption of moisture: these changes in properties are advantageous in some electronic applications. The pendent siloxane groups on polyimides also enhance resistance to atomic oxygen in that they undergo slight degradation to form thin protective silicon oxide coats when exposed to atomic oxygen.

Experiments that demonstrated both alternative approaches to the synthesis of PISOXs began with the synthesis of the precursor PIOHs. Each synthesis of a PIOH (see Figure 1) began with the reaction of an aromatic dianhydride with a diaminobenzohydroly compound in dimethyl acetamide (DMAc) at a temperature of 23 °C to obtain a poly(amide acid). The poly(amide acid) was then added to a solution of DMAc and xylenes refluxing at a temperature of 150 °C to effect thermal cyclization to effect thermal cyclization of the poly (amide acid) to the PIOH. A PIOH prepared in this way remains soluble, whereas a poly(amide acid) that is cast into a thin film and then thermally cyclized cannot be redissolved in DMAc or other suitable solvents (the PIOH must remain soluble in order to use it to synthesize a PISOX).

Figure 2 illustrates the two alternative approaches to the synthesis of a PISOX from a PIOH. In one approach, a hydrogen-terminated siloxane compound or oligomer dissolved in toluene was added to a DMAc solution of the PIOH containing a catalytic amount of chloroplatinic acid (H<sub>2</sub>PtCl<sub>6</sub>·6H<sub>2</sub>O). The reaction mixture was stirred at room temperature for about 16 h under nitrogen. The solution was subsequently cast and dried to obtain the polymer product in the form of a thin solid film. The other approach was similar except that chloroplatinic acid was not used; a chloro-terminated silicon compound or

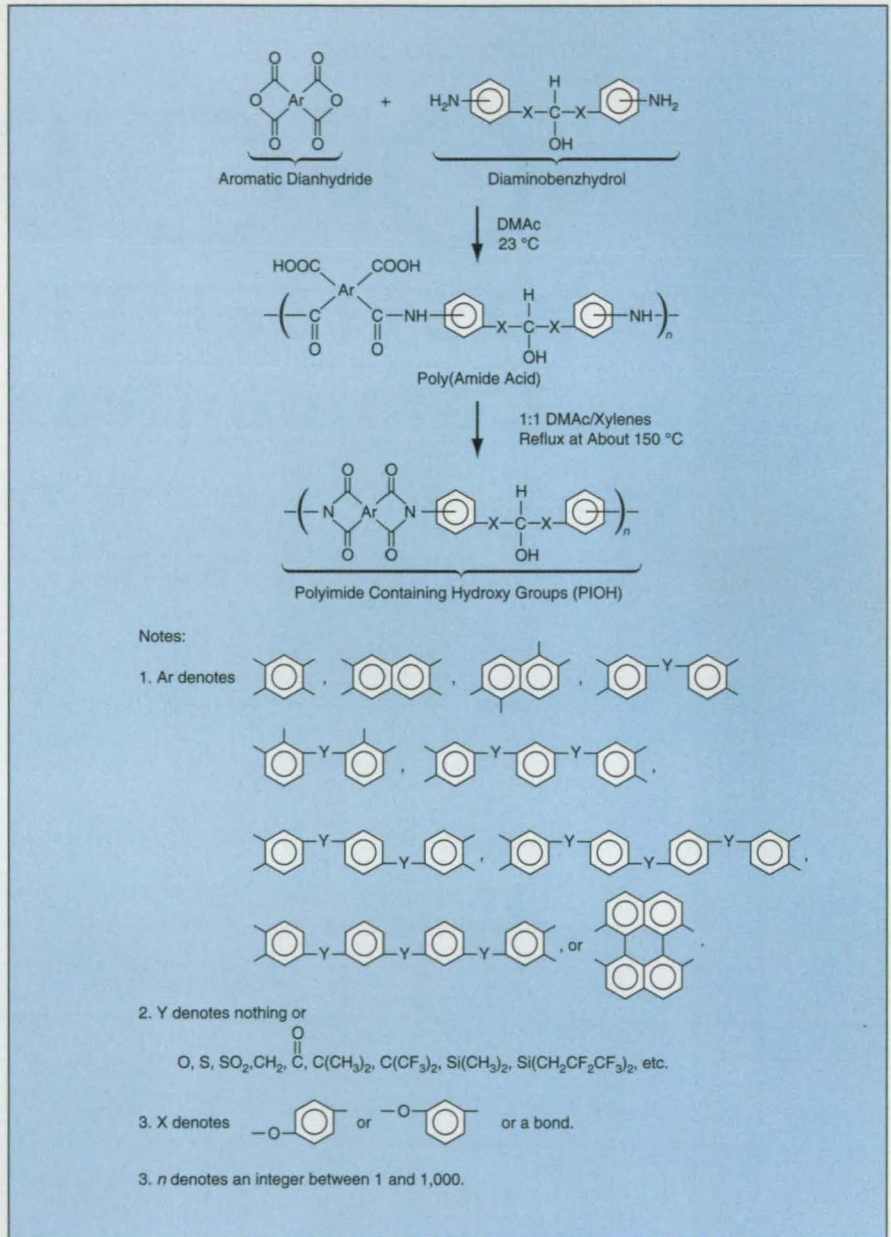

Figure 1. Polyimides Containing Hydroxy Groups (PIOH) are synthesized as soluble precursors to polyimides that will contain pendent siloxane groups.

oligomer was used instead of the hydrogen-terminated siloxane compound or oligomer, and hydrochloric acid was evolved during the reaction.

The PISOX films thus formed were translucent, with colors varying from tan to light brown. The glass-transition tem-

peratures of the PISOXs ranged from 167 to 235 °C. Thermogravimetric analysis showed 5-percent losses of weight at temperatures near 380 °C in both air and nitrogen. The tensile strengths and tensile moduli of the films were in the range of 8.2 to 15.6 kpsi (57



# EMSS Quantum Leap

## FOR MECHATRONICS

### TRANSIENT SOLUTIONS FOR ELECTROMECHANICAL SYSTEM SIMULATION

**EMSS** is a technology breakthrough in the design and analysis of electromechanical systems. This leap in technology combines finite element analysis (FEA), mechanical dynamics and electronic circuit equations in a comprehensive, easy-to-use software package for electrical and mechanical engineers.

With EMSS, electromagnetic devices designed with Ansoft's Maxwell software are simulated under true operating conditions. Voltage and current excitations from the drive circuitry combined with electrical and mechanical loads and mechanical motion are accurately simulated on MS Windows based PCs and Unix workstations.

Ansoft, the leader in electromagnetic analysis, has bridged the gap between electrical, mechanical and electronic engineers with one easy-to-use software package that drastically reduces time to market. Applications include: solenoids, transformers, sensors, and a host of other electromechanical devices.

EMSS includes a schematic capture module to drive transient simulations, offering graphical editing of electrical circuit models with automatic node numbering. The equivalent electrical circuit can be solved in either Maxwell SPICE or exported to Analog's Saber format.

Once the circuit has been defined and solved, the results can be viewed in the signal post processor. Magnetic FEA simulations need only be completed once and used for both initial conditions and time domain simulations - saving critical design time.

**TAKE THE LEAP. Call 412-261-3200 for a FREE 30 day evaluation package.**

For More Information Write In No. 526

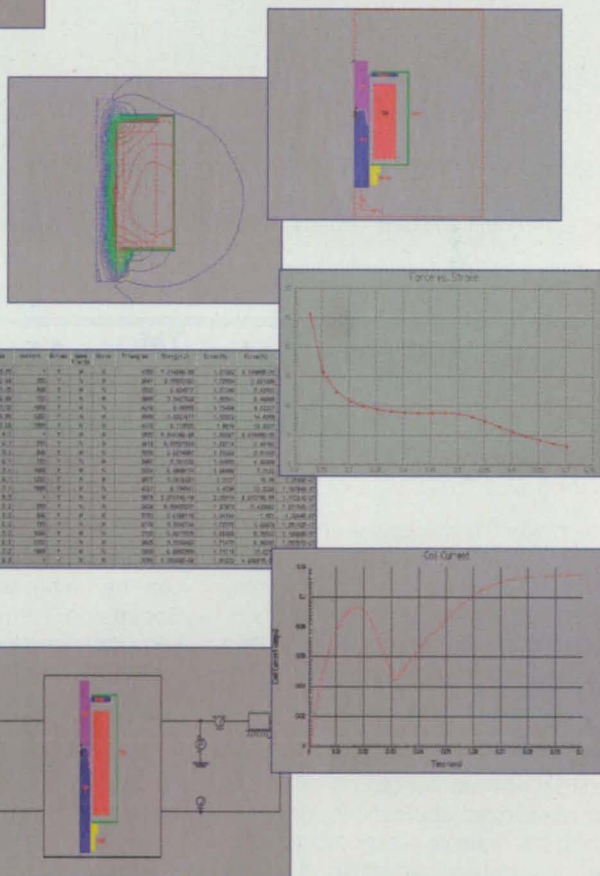

**Ansoft Corporation**  
Pittsburgh, PA 15219-1119 USA  
TEL (412) 261-3200  
FAX (412) 471-9427  
Internet: [EMinfo@ansoft.com](mailto:EMinfo@ansoft.com)  
<http://www.ansoft.com>

to 108 MPa) and 248 to 453 kpsi (1.71 to 3.12 GPa), respectively.

This work was done by John W. Connell, Terry L. St. Clair, and Paul M. Hergenrother of **Langley Research**

**Center**. For further information, **write in 83** on the TSP Request Card.

This invention has been patented by NASA (U.S. Patent No. 5,304,627). Inquiries concerning nonexclusive or

exclusive license for its commercial development should be addressed to the Patent Counsel, Langley Research Center; (804) 864-3521. Refer to LAR-14638.

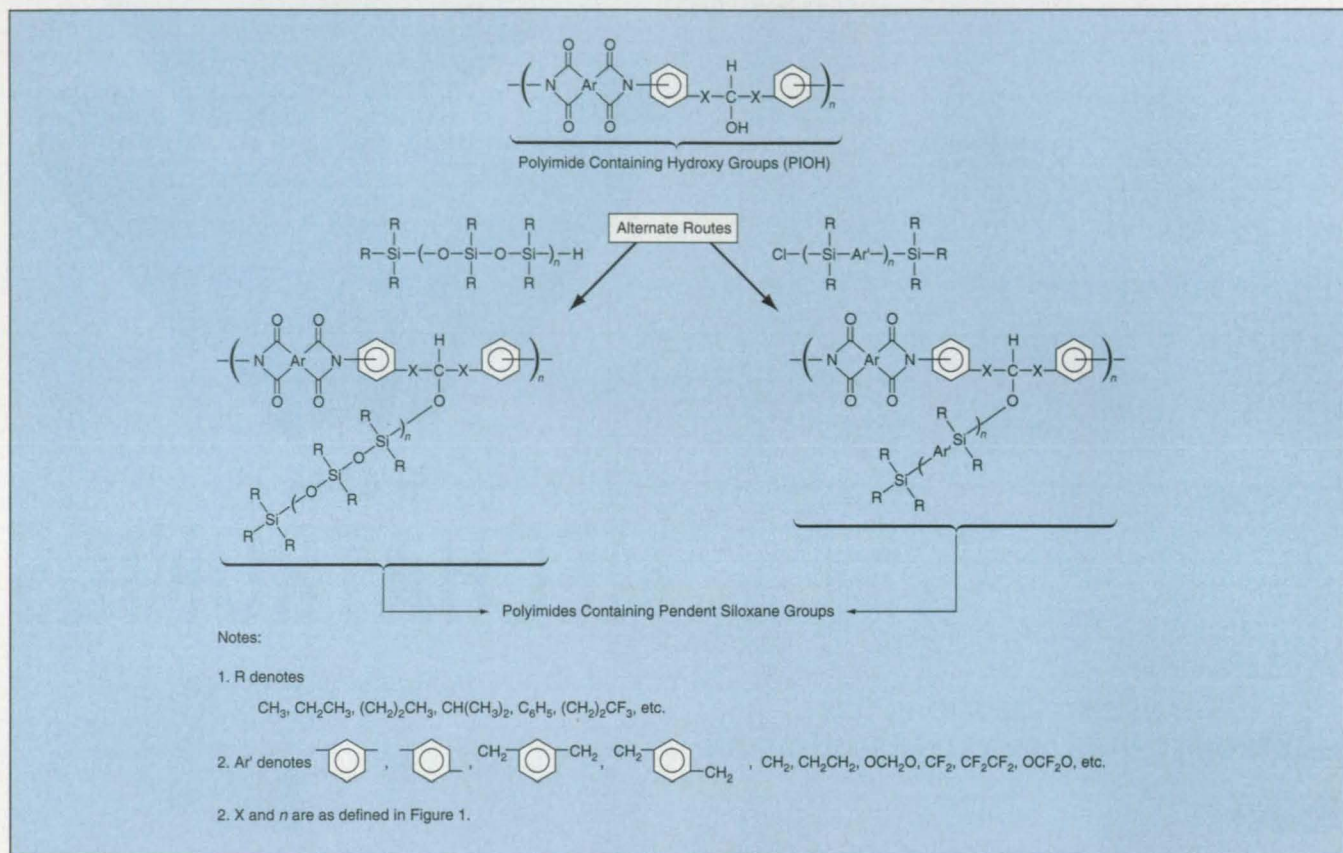

Figure 2. Pendent Siloxane Groups of two different types are incorporated according to two alternative approaches.

## Cleaning Spectralon™ to Maintain Reflectance Properties

Vacuum baking removes impurities that participate in photochemical degradation under ultraviolet light.

NASA's Jet Propulsion Laboratory, Pasadena, California

Spectralon™ is a unique and potentially important reflectance material for space applications due to its highly Lambertian reflectance distribution function, which is maintained over a long wavelength range. As supplied by the manufacturer, Spectralon™ is quite stable and retains its reflectance properties indefinitely in most terrestrial and extra-terrestrial environments.

For specialized applications, however, in which the material is exposed to ultraviolet or vacuum ultraviolet radiation, degradation in its reflectance properties, particularly in the low wavelength region of the spectrum, is observed. These changes are due to trace amounts of volatile hydrocarbon impurities, inherent in the resin used to manufacture Spectralon™, that, upon irradiation, con-

vert into a yellow absorbing layer on the surface. These hydrocarbon impurities can be removed and the stability of Spectralon™ towards ultraviolet and vacuum-ultraviolet radiation greatly enhanced by baking the material at 90 °C for 24 h in a vacuum of  $10^{-5}$  torr (about  $10^{-4}$  Pa). After the vacuum bake, the material should be handled with white cotton, lint-free gloves in a clean environment (preferably a cleanroom). As the material has a tendency to reabsorb volatile organic compounds, it should be stored and transported only in clean, airtight (preferably glass or oil-free metal) containers. The material should not be placed in plastic containers or bags because plasticizers and organic antistatic agents can readily leach from those containers and recontaminate the materials.

Spectralon™, cleaned and handled in the described manner, is photochemically stable and maintains its reflectance properties, even after extensive exposure to solar ultraviolet light. It should be noted that, except for these trace volatile hydrocarbons, Spectralon™ is a very pure material, and cleaning procedures which utilize washing, particularly with organic solvents, can frequently increase the contamination level and should be avoided.

This work was done by Albert Stiegman, Carl Bruegge, and Gary Plett of Caltech for NASA's Jet Propulsion Laboratory. For further information, write in 79 on the TSP Request Card. NPO-19048

# FEDERAL LAB Computing TECH BRIEFS

Supplement to *NASA Tech Briefs*  
January 1996 Issue Published by Associated Business Publications

## CyberSight True 3D Motion Imaging System

A digital system generates time sequences of high-resolution 3D surfaces of moving objects.

*Lawrence Livermore National Laboratory, Livermore, California*

Using a stereo video camera system and sophisticated computer software, researchers at Lawrence Livermore can digitally capture and display moving three-dimensional subjects to a high degree of realism. The technology, dubbed CyberSight, could lead to improved health care, better multimedia and manufacturing techniques, and more realistic cinema.

CyberSight, an exacting 3D motion imaging system, takes a step beyond the available active marker-based motion tracking systems and allows true three-dimensional images of electronic figures digitized from real actors to be manipulated using computer graphics techniques.

The 3D surface generated by CyberSight represents the true dimensionality of moving objects and thus can be used to quantify the dynamics and kinematics of moving objects. Accurate biomechanical measurements such as velocity, force, and torque can be estimated from the 3D surface models. With this technology, biomechanical analysis of disabled and geriatric patients and patients suffering from repetitive stress syndrome, as well as sports analysis, can be performed more accurately and with better visualization for diagnostics. CyberSight can also be used for 3D analysis of lip movements for speech recognition and speech therapy.

CyberSight begins with stereo computer-vision techniques. The basic hardware includes a pair of CCD cameras separated by a small baseline, which capture two images from slightly different perspectives; real-time framegrabbing and image storage boards; a light projector that projects a set of line patterns as landmarks for stereo registration; and a host computer.

The system extracts line patterns from each image using a zero-crossing algorithm to obtain subpixel alignment accuracy, and then matches them with their

counterparts in the stereo pair of images. Pixel-to-pixel match between the lines is optimized based on image intensity cues.

Spatial location of a pair of matched image points is calculated using the principle of triangulation. The surface textural prop-



**A Single Reconstructed 3D Frame** displayed with texture overlay (left) and without, from two different perspectives, front view (top) and side view.

erties can be extracted from the original stereo images and used as texture overlay for the 3D reconstructed surfaces.

In its current configuration, CyberSight uses 512-X-512-resolution cameras, 12-mm lenses, and 17-cm baseline separation of the stereo pair. The real-time framegrabbing board captures stereo images at the video rate of 30 fps, and stores up to 1.5 s of motion sequences. In this configuration, the optimal operating range is between 1-3 m from the cameras. At 1.5 m, a single reconstructed human face contains approximately 15,000-20,000 3D data points that can be rendered and visualized using 3D graphics software. The reconstruction takes one minute on a SPARC-10 workstation. The reconstruction accu-

racy is 0.2 mm on the average for a planar object facing directly into the camera. Error increases as the angle of the surface increases. Experiments are currently being conducted to quantify the accuracy of curved surfaces.

*This work was done by Shin-ye Lu and Robert K. Johnson of Lawrence Livermore National Laboratory, Livermore, CA. Inquiries may be directed to Shin-ye Lu at (510) 422-6882.*

*A patent application on this invention has been filed. Inquiries concerning rights for the commercial use of this invention should be addressed to the Technology Transfer Initiative Program, Lawrence Livermore National Laboratory; (510) 422-6416.*

## Development Tool to Improve Information Integration and Management

Application Interface Engine makes programming easier.

Argonne National Laboratory, Argonne, Illinois

Argonne's Application Interface Engine (AIE) provides a flexible software design environment that overcomes the limitations of single-function commercial tools for developing database interfaces and mapping systems. Such tools can restrict software developers who need to solve problems that require multifunctional and complex applications, including interfaces to existing code, distributed databases, and heterogeneous networks.

To solve these problems, developers must integrate existing software and new programs into a single, cohesive system. By using AIE, developers can improve overall information integration and management. With AIE, application engineers can focus on end-user requirements instead of being distracted by the low-level details of programming. The developers can also use rapid prototyping methodologies to quickly demonstrate the application to end users. As a result, users can be fully involved in the development process, from defining initial requirements to refining the appearance and overall flow. The finished computer applications are graphically oriented, easy to use, and most importantly meet the users' requirements.

The AIE lets applications engineers program in an object-oriented language that is specially designed to represent user interfaces and graphical applications. The baseline AIE system consists of component modules that access different resources and perform various functions. These modules display user interface windows; draw geometric objects, presentation graphics, and cartographic information; access multimedia data from distributed databases; and communicate with other programs across a computer network. The system runs on both Sun workstations (XWindows) and PC compatibles (Microsoft Windows). Since its initial development in 1991, AIE has been used successfully to develop many models and information management systems. Argonne is currently enhancing AIE to increase its functionality for mapping and visualization.

Researchers have developed a strategic plan and procedures guide for formal quality assurance/configuration management during the further development of AIE. This plan will guide the addition of new features, so that AIE keeps pace with advances in the computer field. Some features being explored are animation and simulation that make use of emerging artificial intelligence techniques.

*This work was done at Argonne National Laboratory, Argonne, IL. For technical information, contact James Peerenboom at (708) 252-8994 or Mary Ann Widing at (708) 252-3798.*

*This software is copyrighted and is available for licensing. For more information on licensing, contact Don Knight of Argonne's Industrial Technology Development Center at (708) 252-6128.*

## Monitor Shields

**A Few Shields Or A Few Thousand —  
We're Geared For Any Production Peak.**

**M**agnetic shielding — *that's our specialty.*

And we are equipped to handle any

monitor shield-

ing requirement

you may have.

It's a matter of

applying our

experience with

our production

facilities to

produce

your monitor

shielding

needs on the most demanding schedule. We can

prove it. Please request our latest catalog.

*The Problem Solving Magnetic Shielding Specialists*

**AD-VANCE MAGNETICS, INC.**



625 Monroe Street  
Rochester, Indiana 46975  
(219) 223-3158 • FAX (219) 223-2524

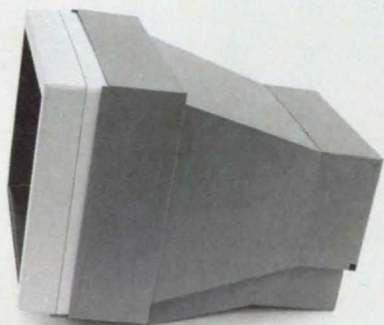

# The World's Most Rugged Laptop!

## FieldWorks 7000 Series Field WorkStations



Patented backplane/card cage design allows up to 3/6 ISA slots or 3+3 ISA and PCI slots (FW 7600P).

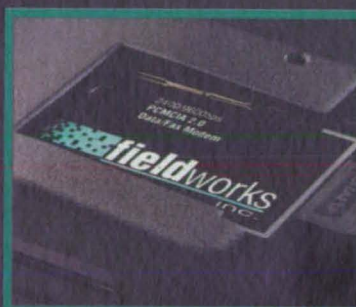

Integral type I-IV PCMCIA slot permits use of credit-card sized removable hard drives, RAM, Fax-modems, LAN adapters and other functions without the need to utilize any card cage slots.

**FieldWorks introduces** the first professional field computing platforms designed specifically for Field Service, Field Sales, and other professions requiring high-powered mobile computing in a lightweight, ruggedized design. The FieldWorks FW 7000 Series Field WorkStations™ were designed to meet military electronics specifications while providing 6 open IBM standard ISA slots for auxiliary test, measurement, diagnostic, Multi-media, and/or communications cards. High strength and low weight is achieved through the use of a Magnesium and Aluminum structure much like today's aircraft spaceframe/skin concept. The 100MHz DX4 486 or Pentium processors provide state of the art speeds under AC(Mains), battery, or 12VDC output power. Integral CD ROM option, type I-IV PCMCIA card expansion, 64Mb on-board RAM capability, VGA Color Screen, ISA expansion slots and the unique Field MousePad technology make FieldWorks WorkStations the logical choice for integrated field automation systems.

- 100g Operating Shock (Mil-Spec 810C)
- 100 MHz 486 DX4 and Pentium Options
- 3/6 ISA Slots or 3+3 ISA/PCI Slots
- 1 PCMCIA Slot (type I-IV): More Optional
- Integral CD-ROM Drive
- Sealed Mouse Pad Pointing Device
- One Piece Magnesium Chassis
- Battery Options
- Removable Hard Drive Options

For More Information Write In No. 450

# fieldworks

inc.

1 Valley View Road ■ Eden Prairie, MN 55344, U.S.A. ■ Phone: 612-947-0856 Fax: 612-947-0859  
Federal Business: Phone: 703-913-4800 Fax: 703-913-4801  
Sales Department/Customer Service: 612-947-0137 ■ Designed and Manufactured in the U.S.A.



# Computer-Assisted Trolley Fault Detection Using Neural Networks

A system detects trolley faults not discernible to existing circuit protection devices.

Pittsburgh Research Center, US Bureau of Mines, Pittsburgh, Pennsylvania

The Bureau of Mines is currently investigating the electrical characteristics of arcing and other types of faults on mine DC trolley systems. One approach permits the detection of such faults without the addition of significant hardware on the trolley systems or vehicles. Similar detection systems may also be used for other types of electrically powered rail systems.

Trolley systems constrained to move on a network of steel track are used in mining operations for the transportation of personnel and supplies. Such systems typically employ a suspended trolley wire energized at 300 or 600 VDC. Occasionally, roof falls and other accidents may force the trolley line down close to the rail. Electrical arcing between the line and the rail may then induce fires. These fires are not preventable by conventional circuit protection because the arcing currents can be significantly smaller than typical circuit-breaker settings.

Research tests are continuing on trolley systems at cooperating coal mines.

Trolley rectifier voltage and current signatures are recorded during normal loading (light, medium, and heavy traffic), during induced fault conditions (resistive and arcing faults), and during transitions between the two.

The data signals are low-pass filtered and digitized via a 12-bit analog to-digital converter (ADC). This digital data is then analyzed using commercially available software. The analysis focuses upon the magnitude components of the frequency spectra generated by fast Fourier transforms (FFTs). For each test, successive FFTs are generated using a window size of 1024 samples. As an additional noise reduction measure, the FFTs are grouped into sequential sets of four and averaged.

The frequency spectra generated from the DC voltage signal exhibit a prominent fundamental frequency at 360 Hz. This represents the ripple generated from the fully rectified three-phase AC input to the rectifier. This component and its harmonics tend to obscure the lesser components of interest in the spectrum.

Because this effect is less evident in the DC current spectrum, and it is the current that must be interrupted if a fault is detected, the bulk of the analysis focuses on the DC-current signal recordings.

The results indicate that there is sufficient spectral information in the range from DC (0 Hz) to 10 kHz to differentiate between normal operation of the trolley system and fault conditions. The FFTs of the data generated under fault conditions illustrate significantly more leakage, or blurring, between frequencies than data collected under normal conditions. This broadens the lobes of the spectrum and offers obvious visual evidence of the difference.

The spectral data for the DC current is used to train and verify the operation of an artificial neural network. The input patterns for this network consist of the spectral frequency magnitude components up to 9960 Hz, including the DC component. Because of the ADC sampling rate (61,440 samples/second) and the window size (1024 samples), a magnitude component is generated from DC to 9960 Hz in 60-Hz increments. To train the neural network, precise extractions are made from the test data to capture particular conditions on the system. These include normal traffic, no traffic, induced faults, and combinations of these conditions. This group of patterns is then split to provide one set for training the neural network and the other for verifying performance.

The neural network is trained to produce an output of +1 for normal operation and -1 to indicate a fault condition. The system is designed to operate in quasi-real time, reading a window of data, then analyzing and classifying it as normal or faulted. To avoid nuisance tripping, e.g., classifying a normal pattern as faulted and interrupting current flow, a condition was added not to interrupt the current until the neural network indicated a fault for three consecutive scans. Using these criteria, the network proves to be accurate 92% of the time.

*This work was done by Michael R. Yenchek, J. Shawn Peterson, and Gregory P. Cole of the Pittsburgh Research Center, US Bureau of Mines. Inquiries should be sent to J. Shawn Peterson, US Bureau of Mines, Pittsburgh Research Center, PO Box 18070, Cochrans Mill Rd., Pittsburgh, PA 15236-0070.*

## SoftwareWedge™

Automatically inputs any serial data directly into any PC application.

Any Windows, DOS, NT, or Win'95 Application

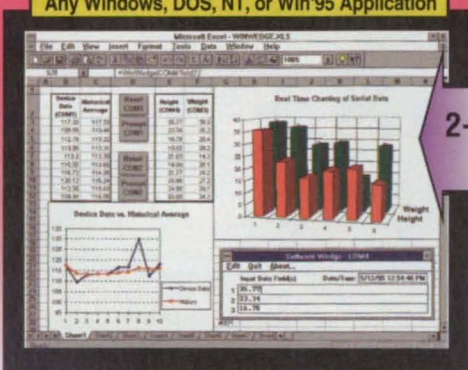

Capture data from:  
Industrial, laboratory, & medical instruments ...  
data loggers ... analyzers ...  
PLCs ... gages ...  
bar code readers ...  
electronic balances ...  
sensors ... modems ...  
telephone systems ...  
**Any Serial Device!**

2-WAY  
I/O

Now Also For  
WINDOWS 95!

- Add serial data acquisition and instrument control to any Windows or DOS application.
- Input real-time serial data into Excel, Lotus, Quattro, VB, SPC, LIMS, control programs, etc.
- No programming. No special hardware.
- Powerful DDE support in Windows
- Extremely easy to set-up and use.
- Unlimited free technical support.
- NEW! Powerful "Pro" versions.
- Risk-free 90-day guarantee.

Call toll-free:  
800/722-6004

TAL TECHNOLOGIES, INC.  
2027 Wallace St., Philadelphia, PA 19130  
Tel: 215/ 763-7900 Fax: 215/ 763-9711  
E-mail: tal1@taltech.com  
Home page: <http://www.taltech.com>

**TAL**  
InstrumentAL Software™

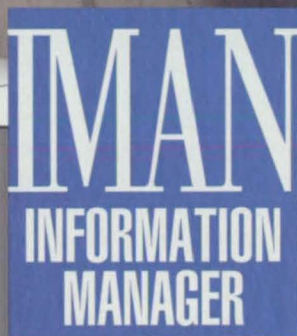
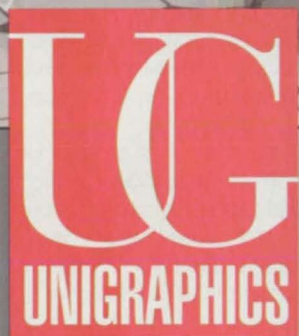

# Pure Speed

**Design, Analysis, Mockup, Prototyping, Manufacture**

*"Regarding modeling, the Unigraphics approach to integration of surfacing with solids represents possibly the best solution in the industry.*

D.H. Brown, August 1995

*"IMAN has a very full toolkit and a strong architectural foundation. The product also boasts the industry's best CAD integration..."*

D.H. Brown, May 1995

Pure speed—like the Benetton Formula 1 race car—just doesn't roll off the assembly line. The right combination of technologies, teams and processes makes it happen. That's why Benetton uses EDS Unigraphics' products, and that's why our unique strengths extend far beyond CAD/CAM/CAE.

■ Unigraphics' Hybrid Modeler provides pure speed in modeling and ultimate handling on the tightest of curves and surfaces. Complex design challenges are attacked with the most powerful solid, surface, wireframe and feature-based parametric modeling tools. Legacy data can be quickly edited and parameterized, and assemblies of more than 1,000 parts readily manipulated. The drafting engine makes it easy, even intuitive, to document designs. And unique CAM strengths enable extremely complex freeform shapes to be cut with confidence and accuracy.

■ The IMAN product data management (PDM) system provides ultimate control in a product's race to market, and through a long life cycle of improvements. IMAN's modular structure is ideal for a phased implementation. An open architecture delivers the flexibility to be customized, if needed, to a company's particular needs. IMAN's link to geometric modeling is unparalleled, for example, direct links can be readily made between geometric parts in an assembly and bills of material.

But pure speed is far more than software. It's your team driving high-performance manufacturing practices supported by appropriate communications technology. Here, our parent company EDS continues to help set the track record for customer performance worldwide with proven systems development, integration and operations.



EDS Unigraphics

Experience pure speed with EDS Unigraphics and Hewlett-Packard. Drive EDS Unigraphics software on HP 9000 Series 700 workstations. For more information, call 314-344-2687. Also, check out our World Wide Web site at <http://www.ug.eds.com>.

EDS, Unigraphics and IMAN are trademarks or registered trademarks of Electronic Data Systems Corporation. All other trademarks or registered trademarks belong to their respective holders. Copyright © 1996 EDS. All rights reserved.

**For More Information Write In No. 451**

# FEMAP

Finite Element  
Modeling and  
Post-Processing

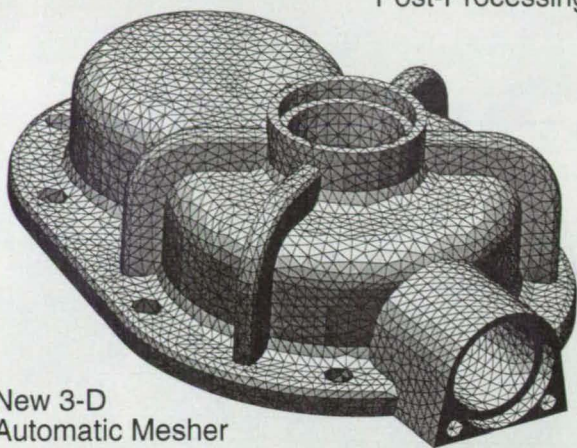

New 3-D  
Automatic Mesher

Direct Interfaces with:

- AutoCAD R13
- AutoCAD Designer
- MicroStation Modeler
- Stereo-Lithography
- IGES, DXF

Available for:  
Windows  
Windows 95  
Windows NT  
and UNIX

Supports Twenty Finite Element Analysis Programs

**ENTERPRISE SOFTWARE PRODUCTS, INC.**

610-594-2454 • 610-594-7579 FAX • femap@pond.com E-Mail

FEMAP ADVANCED MESHING MODULE utilizes ACIS software by SPATIAL TECHNOLOGY INC.  
All Product Names are Trademarks or Registered Trademarks of their respective owners.

For More Information Write In No. 462

## Still strain-gauging your parts?



Next time measure your stresses  
nondestructively. Because if it's not  
broken, why break it.

**TEC** PRODUCTS and LAB SERVICES  
10737 Lexington Drive, Knoxville, TN 37932  
423-966-5856 fax: 423-675-1241

For More Information Write In No. 463

## Interactive Manufacturability Analysis and Critiquing System (IMACS)

An automated designer's aide evaluates  
the manufacturability of machined parts.

*Institute for Systems Research, University of  
Maryland, College Park, Maryland*

Because of pressing demands to reduce lead time for product development, it is becoming increasingly important to analyze the manufacturability of proposed products during the design stage. By so analyzing machined parts once the geometry and tolerances have been specified, IMACS will help in creating designs that not only satisfy the functional requirements but are also easy to manufacture.

IMACS can identify manufacturing difficulties, interactively, as the designer creates a design. It is currently being extended so that it will propose design alterations that improve manufacturing cost and time. IMACS works by generating and evaluating alternative operational plans, in order to see whether one exists that can create the design, what the best operation plan is, and what kinds of machining problems might occur. Since many such problems can only be detected at the planning level, existing rule-based commercial systems often have difficulty in capturing them.

Fundamental components of this system are: (1) a module for recognition of machining features from a CAD model (which IMACS represents using ACIS, a solid-modelling system from Spatial Technologies Inc.); (2) a module for generating and evaluating operation plans from the features returned by (1); and (3) a module for suggesting design modifications to the designer to improve manufacturability while maintaining the functional intent. The first two modules have been implemented; implementation of the third is under way.

*IMACS represents a collaborative effort among faculty and students from several University of Maryland departments, including the Institute for Systems Research, the Computer Science Department, and the Mechanical Engineering Department, with funding from the National Science Foundation. Personnel include Dana S. Nau (project leader), Diganta Das, Satyandra K. Gupta, Ioannis Minis, William C. Regli, and Guangming Zhang.*

*Inquiries concerning rights for the commercial use of IMACS should be addressed to Bob Karig, Institute for Systems Research, University of Maryland, College Park, MD 20742; (301) 405-6604; E-mail: karig@isr.umd.edu.*

## Mobile Robot Radiation Mapping (RADMAP)

The technique allows for real-time display of  
alpha, beta, and gamma radiation information.

*Savannah River Technology Center, Aiken,  
South Carolina*

A software package developed at Savannah River Technology Center enhances mobile robotic systems used for radiation detection and waste inspection. Mobile Robot Radiation Mapping (RADMAP) reads radiation data gathered by a robot and



displays it on a remote computer screen as a color-coded two-dimensional map overlaid onto a building's floor plan.

RADMAP displays data in an easily digested format and, in its latest version, allows for real-time display of alpha, beta, and gamma radiation information. Operators of a robot such as the technology center's SWAMI (Stored Waste Autonomous Mobile Inspector) can follow the robot's path, for example, through a warehouse containing drums of radioactive waste and see the data collected in real time.

With RADMAP, the operator can recognize instantly where high radiation points are and then can use the software to inspect the points. All radiation data are plotted in the exact shape, position, and orientation of the detector when the readings are taken, so the operator can tell exactly what areas were surveyed.

A movie feature built into RADMAP allows for the animation of data and the display of the robot's exact path. Also to be added is a simulation capability that graphically displays a robot's path beforehand to ensure thorough inspection of an area. Data gathered manually from places where the robot cannot go, such as corners, can be entered easily into the RADMAP program.

Other RADMAP features include full pan and zoom capabilities and a mode to "bubble up" higher radiation readings to prevent them from being obscured on screen. If unusually high levels are detected, a warning window alerts operators.

RADMAP is updated and improved as new projects warrant, and work on a third version is under way. A copyright is pending, and the software should be available this year. The latest RADMAP package will be available for SUN computers running SunOS v4.1.3, X1 1R5, and Motif v1.2.

This work was done by Clyde Ward for the **Savannah River Technology Center**. The Center, operated for the Dept. of Energy by Westinghouse Savannah River Company, is the applied research and development laboratory serving the Savannah River Site.

Inquiries concerning rights for the commercial use of this invention should be addressed to the Economic Development Division, Westinghouse Savannah River Co., 227 Gateway Drive, Aiken, SC 29803; (800) 228-3843; FAX (803) 652-1898.

### COMING IN FEBRUARY

In next month's issue *NASA Tech Briefs* will announce the winner of the 1995 Product of the Year Award, chosen by reader ballot from among the year's featured Products of the Month in "New on the Market."

## Reviewer's Assistant Helps Find Potential Design Problems

"Case-based reasoning" aids in review of architectural and engineering designs.

*Construction Engineering Research Laboratories (CERL), Army Corps of Engineers, Champaign, Illinois*

During the architectural and engineering design of facilities, there are several points at which project stakeholders are given an opportunity to comment on partially completed plans and speci-

cations. These opportunities are critical to successful project outcomes, since future builders, occupants, and maintenance personnel may suggest improvements to the plans and specifications

# NEW!

## Save Time & Money with the FREEPOINT 3D Digitizer

The Most Versatile and Affordable 3D Digitizer for:

- Rapid Prototyping
- Reverse Engineering
- Modeling
- Design
- Animation
- Measurement
- Inspection

**Freedom to Digitize in 3 Dimensions**

**Unique Digitizing Features:**

- Large Volume – up to 16 x 8 x 8 ft.
- Digitize any material – including metals
- Hand-held Flexibility
- Portable

**Broad Software Compatibility:** Works with most leading 3D CAD software.

Call for a FREE brochure or demonstration!  
410-381-6688

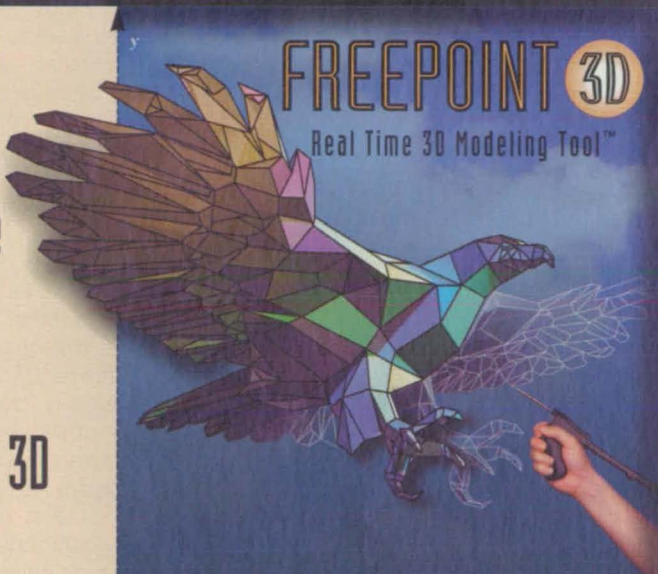

**SCIENCE ACCESSORIES**  
New Dimensions In Digitizing

7125 RIVERWOOD DR. COLUMBIA, MD 21046  
TEL 410-381-6688 FAX 410-290-9065

# Low-Pass Filters

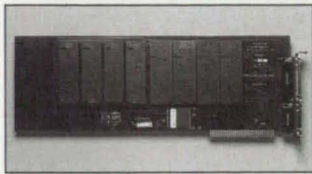

Alligator Technologies' low-pass filter boards work with any A/D, solve your aliasing and noise problems, and give you improved data accuracy. We offer:

- **PC Filter/Amplifier Cards**
- **Precision Analog Filters for Rackmount and VXI/VME Systems**
- **RS-232 Programmable Boards for Harsh Environments**

Call us today for applications assistance.



2900 Bristol, E-101, Costa Mesa, CA 92626, FAX 714-850-9987

**714-850-9984**

For More Information Write In No. 465

of the facility these stakeholders ultimately will have to build, live in, and maintain. These opportunities, called design reviews, are part of most public and private organizations' design processes and are recommended by design professionals. There are, for example, a minimum of two design reviews on US Army Corps of Engineers projects, one at the concept design stage and one at the final design stage.

The goals of the design reviews include identification of potential problems related to errors, omissions, and inconsistencies in future construction plans and specifications that may keep contractors from providing reasonable project bids; avoidance of increases in construction costs due to inappropriate use of materials and/or building methods; and avoidance of additional operation and maintenance expenses through incorrect installation of components and/or building systems. In addition, the reviews must consider the complex infrastructure of local and regional codes, historical preservation requirements, environmental compliance regulations, and other requirements under which the project will be built, operated, and maintained.

Experienced design reviewers are under great pressure to conduct timely and complete reviews. These experienced personnel rely on their understanding of past problems with similar building components or systems to identify problems with new projects. Ultimately the similar problem areas should be identified and specifications adjusted to remove this repetition. The time pressures to conduct reviews and the number of comments that must be evaluated to identify repetitive items make the experienced design reviewer's task very challenging.

Less experienced reviewers, or those who do it infrequently, are often not sure where to start when faced with the review of a large set of plans and specifications. These personnel need a way to access captured expertise to find potential problems. They may also need access to the comments that others have made in the past or to reference materials that pertain to a portion of the design being reviewed.

The innovative set of ideas forming the basis for this project is called "case based reasoning." Through such an approach, the user identifies comments, with computer-assisted techniques, as belonging to specific components, systems, or categories of projects. If he is encountering a similar situation, he can draw upon the reviewer's past experi-

ence. The program that makes this possible is named Reviewer's Assistant. A supplemental program, the Lessons-Learned Generator, identifies frequently used comments and classifies them as a set according to common elements.

Reviewer's Assistant is easy to operate once the user is comfortable using a computer. It can run on a 286 personal computer that has at least 640k random access memory and a color monitor. A recommended platform is a 386/33 machine, however. Depending on the application, it may also run under a Windows environment.

Improving the efficiency of design reviews should not only increase customer satisfaction upon moving into a new facility, but also decrease the largest costs—those associated with maintaining a facility over an average 30-year life span. While there is a minimal first cost required to train Reviewer's Assistant system users—it takes about 4 hours—the benefit in returned construction contingency funding and reduction in life-cycle facility costs should be significant. There is no investment for the software, which has already been sent to more than 600 government and private-sector architectural/engineering organizations to provide input for enhancements.

Reviewer's Assistant is the second in a series of projects conducted by CERL to enhance design quality. The first effort, the Automated Review Management System (ARMS), provides tools for planning and executing design reviews. Since project participants may be scattered across the continent or in different countries, the ability to centrally track comments and route them to all project participants is vital for a complete design review. ARMS users have indicated that a 5-percent decrease in construction contingency has resulted from the use of this electronic tracking and transmission system.

CERL seeks to commercialize the Reviewer's Assistant software in two ways: by licensing the existing DOS environment product and by entering into a cooperative research and development agreement to develop a Windows version.

*This work was done at the Construction Engineering Research Laboratories, Army Corps of Engineers. Inquiries should be addressed to E. William East, COMM, USACERL, PO Box 9005, Champaign, IL 61826-9005; (217) 373-6710; (800) USA-CERL; FAX (217) 373-6724.*

## LITERATURE SPOTLIGHT

Free catalogs and literature for *Federal Lab Computing Tech Briefs'* readers. To order, write in the corresponding number on the Reader Information Request Form (after page 64).



### MACINTOSH IN ENGINEERING

Everything you wanted to know about the Macintosh in engineering and science. Free issue *SciTech Journal*. Application articles, technology briefings, new products, OS Wars column, and more. Check out our Web site at <http://www.macscitech.org/>.

MacSciTech Association, 49 Midgley Lane, Worcester, MA 01604; Tel: 508-755-5242; Fax: 508-795-1636; Web: <http://www.macscitech.org/>.

**MacSciTech Association**

For More Information Write In No. 300



# Computer Programs

## COSMIC: Transferring NASA Software

COSMIC, NASA'S Computer Software Management and Information Center, distributes software developed with NASA funding to industry, other government agencies and academia.

COSMIC's inventory is updated regularly; new programs are reported in *Tech Briefs*. For additional information on any of the programs described here, write in the appropriate TSP number.

If you don't find a program in this issue that meets your needs, call COSMIC directly for a free review of programs in your area of interest. You can also purchase the annual *COSMIC Software Catalog*, containing descriptions and ordering information for available software.

COSMIC is part of NASA's Technology Transfer Network.

COSMIC® —

Timothy L. Peacock, Director

Phone (706) 542-3265;

FAX (706) 542-4807

The University of Georgia,

382 East Broad Street,

Athens, Georgia 30602

## Manufacturing/ Fabrication

### Program Simulates a Modular Manufacturing System

All machine operators are assumed to be equally trained and capable.

SSE is a computer program that provides a simulation environment for modeling manufacturing systems that contain relatively small numbers of stations and operators. As a result, the simulation model need not be complex, with the exception of those parts that represent movements of machine operators. SSE has been designed to simulate manufacturing of apparel, but can also be used in other manufacturing domains. SSE is an excellent simulation software package for small or medium-size firms including those that lack the expertise to develop detailed models or have only minimal knowledge in describing manufacturing systems and in analyzing the results of simulations on mathematical models. The user does not need to know a simulation language to use SSE. SSE has been used by a number of apparel-manufacturing firms to design new modules and to evaluate existing modules.

SSE can be used to design and evaluate a modular manufacturing system with one line and a maximum of 18 stations in a series. Each station can include a maximum of eight machines performing identical operations in parallel. A maximum of 26 operators is allowed, and all are assumed to be cross-trained and to be able to work at any station at the same efficiency. SSE can include unlimited space for work in process in front of each station. There must always be enough items in front of the first station to prevent a delay while

waiting for an item. Work is done in lots; a lot can consist of one or many items. SSE also incorporates the assumption that there are no machine breakdowns.

This program was originally written in Turbo C v2.0 for IBM PC-compatible computers running MS-DOS and has been successfully implemented by use of Turbo C++ v3.0. Sample MS-DOS executable codes and sample input/output files are included on the distribution medium. The program requires a VGA graphics display and at least 128K of random-access memory for execution. The standard distribution medium for this program is one 5.25-in. (13.335-cm), 360K MS-DOS-format diskette. This program was developed in 1992.

*This program was written by Bernard J. Schroer and Jian Wang of the University of Alabama in Huntsville for Marshall Space Flight Center. For further information, write in 75 on the TSP Request Card. MFS-26245*



## Electronic Systems

### Program Computes Receiver Gain and Noise Profiles

Performance figures are presented on a spreadsheet.

RCVRPROF computer program is a computer-aided-design (CAD) software tool useful in the analysis and design of communication receivers and downconverters. RCVRPROF provides a customized spreadsheet with formulas and graphs that provide a detailed description of performance of a receiver. Such performance parameters as noise temperature, gain, noise power, noise spectral density, and dynamic range are ana-

lyzed for the contribution of each to overall performance of the receiver.

The spreadsheet is constructed by listing each component of the receiver in order, beginning with the antenna. Each component is described as either "amp" or "pad." If the component has independent gain and noise temperature, then it is of "amp" type (gain in dB can be positive or negative). If the component is passive and its noise temperature and gain are related, it is of the "pad" type, and the only parameter that one need enter is its gain (negative in dB).

The RCVRPROF spreadsheet contains input and output columns, as well as two charts that graphically represent the data. The input parameters are component name, noise temperature, gain, output 1-dB compression point, bandwidth, and signal level. The output parameters are system noise temperature, total system gain, noise power spectral density, total noise power in the band, dynamic range, and headroom. Graphically, one chart shows the contribution of each component to the receiver system noise temperature, while the other shows a gain profile of the receiver chain with the signal level compared to the 1-dB compression point and the receiver noise floor. The charts can be tailored for the specific application.

RCVRPROF has been implemented as a spreadsheet program by use of Lotus 1-2-3 v1.0 and Microsoft Excel v4.0, both for Microsoft Windows v3.1. The standard distribution medium for RCVRPROF is a 3.5-in. (8.89-cm), 1.44MB MS-DOS-format diskette. Documentation is included in the price of the program. RCVRPROF was released in 1994 and is a copyrighted work with all copyright vested in NASA.

*This program was written by Dalia McWatters of Caltech for NASA's Jet Propulsion Laboratory. For further information, write in 49 on the TSP Request Card. NPO-19472*

## Digital Quartz Crystal Pressure Instrumentation

# 0.01% Accuracy

### Digiquartz®

Transducers	Barometers
Transmitters	Manometers
Lab Standards	Depth Sensors

Multiple pressure ranges with one part-per-million resolution to meet your needs in ....

Hydrology  
Aerospace  
Meteorology  
Oceanography  
Process Control  
Energy Exploration  
Laboratory Instrumentation  
ISO 9001

For application / engineering support-call:

## Paroscientific, Inc.

4500 148th Avenue N.E. Tel: (206) 883-8700  
Redmond, WA 98052 Fax: (206) 867-5407



## Mathematics and Information Sciences

### Quantifying Danger to Spacecraft Crews From Orbital Debris

Probabilities of crew injury or loss are estimated by Monte Carlo-style simulations.

The MSCSurv computer program is designed to quantify the conditional probability of losing one or more crew members following the remote likelihood of penetration of orbital debris into a cluster of spacecraft modules that contain crew members. Contributions to the probability of losing one or more crew members are quantified from three significant penetration-induced hazards: rupture of a pressure wall (explosive decompression), injuries induced by fragments, and "slow" depressurization. MSCSurv uses a Monte Carlo-style subroutine to simulate the penetration of thousands of orbital debris particles of various sizes, velocities, and angles of approach (selected according to their NASA-based environment distribution) into a spacecraft of selected exterior geometry. The file of data that specifies this exterior geometry can be created and/or altered by use of a simple spreadsheet program.

Other MSCSurv input files include crew position as a function of time and interior constructions (i.e., protective capabilities) of the spacecraft. In addition to the input files, MSCSurv is programmed to query the user on a variety of assumptions that can alter the probability of losing one or more crew members (crew sleep position, hole-size model, critical crack length prior to rupture of a pressure wall, and the like).

Outputs from the program include (1) values of the probability of losing one or more crew members, both for the entire spacecraft and for each individual module and (2) locations of crew injuries and losses throughout the spacecraft. Through alteration of input assumptions, the user can identify which alterations of the design of the interior of the spacecraft and which alterations of crew protocols can quantifiably improve overall spacecraft safety for occupants following penetration by orbital debris.

MSCSurv was written in FORTRAN 77 for IBM PC-series and compatible computers running MS-DOS. It has been successfully implemented on a DECpc 486-series computer running MS-DOS 6.2. The Microsoft FORTRAN compiler v4.0 or higher is necessary for recompilation of the source code. The standard distribution medium for MSCSurv is a 3.5-in. (8.89-cm), 1.44MB, MS-DOS-format diskette. MSCSurv was released in 1994 and is a copyrighted work with all copyright vested in NASA.

*This program was written by Joel Williamsen of Marshall Space Flight Center. For further information, write in 27 on the TSP Request Card. MFS-31022*

### Windowing System for Test and Simulation

The application programmer's interface is simple, small, and powerful.

The Windowing System for Test and Simulation (WFI) computer program is a Turbo-Pascal-class library that enables the easy and flexible writing of data to window-type displays. Many windowing systems require large amounts of memory and processing time for bit-mapped graphics, and include complicated application-programming interfaces. By using

character-based graphics, WFI lessens the load on both the central processing unit and on the bus. The application programmer's interface in WFI is simple, small, and powerful, eliminating the steep learning curve of other window programming systems. Each routine has been specifically designed to operate in real-time testing and measurement environments or as a part of a simulation process.

This package of software is intended to be embedded in the user's own software for development of application programs. In many cases, functionality may be extended or modified, without changing the source code as it is written, by use of object-oriented programming techniques.

Three window object types are derived from the base-class BCEWindow: VDT, VST, and HelpWindow. The VDT (Virtual Dumb Terminal) object contains methods for simple text display, automatic logging, and scrolling. The VST (Virtual Smart Terminal) object provides a functional equivalent of the Turbo Pascal screen, with a simple user interface, cursor addressing, a variety of text colors and attributes, and logging. The Help Window is used for viewing text files, which are typically help files or source code.

These three window types, when created, are placed on a heterogeneous list called "Wall." The Wall object points to a linked list of all window objects. Wall methods are defined to enable operations common to all windows with only a single user command. Operations that can be performed by Wall include window redraws, turning logs on and off, supplying window information, and dumps to disk or printer.

WFI is written in Turbo Pascal v6.0 for IBM PC-series and compatible computers running MS-DOS. Turbo Pascal v6.0 or v7.0 (Borland) is required to compile the source code. Five demonstration executable codes with source code are provided on the distribution medium. These executable codes require at least 34K of random-access memory and DOS 3.1 or higher. The standard medium for distribution of this program is one 3.5-in. (8.89-cm), 1.44MB, MS-DOS-format diskette. An electronic copy of the documentation is provided in ASCII format on the distribution medium. WFI was developed in 1993.

*This program was written by R. Katz of Goddard Space Flight Center. For further information, write in 14 on the TSP Request Card. GSC-13632*

# Engineered for Your Environment

**EE Engineering Environments™** – An innovative furniture system designed to optimize your technical work environment.

- Increases productivity by organizing equipment for instant access
- Unmatched strength and stability support the heaviest instrumentation
- Superior cable management • Countless configuration choices
- Integrated ESD controls for sensitive environments • Lifetime Warranty

For NEW Color Brochure: Call 800-225-7348 or 508-852-4300. FAX 508-853-8904.



W R I G H T • L I N E technical furniture solutions

For More Information Write In No. 429

**Product of the Month**



**KP-D50**

Hitachi scores with the KP-D50, a DSP color camera providing enhanced performance for image processing applications. The unit is fully RS232 controllable and features 768x494 pixels on a 1/2-inch Interline Transfer CCD. White suppression, black stretch, contour compensation and 2H enhancement provide the highest quality pictures under adverse conditions. The KP-D50 has NTSC, Y/C and RGB outputs as well as external sync capability. With 470 line resolution and 50db S/N ratio, this camera is a winner!

Call for a demonstration.

**HITACHI**

**Hitachi Denshi, Ltd.  
Hitachi Denshi America, Ltd.**

▲ New York 516-921-7200  
▲ Los Angeles 310-328-6116

▲ Atlanta 404-242-3636  
▲ Dallas 817-488-4528

▲ Chicago 708-250-8050  
▲ Canada 416-299-5900



## SR-71 Experiment on Propagation of Sonic Booms

Data will be used to soften sonic booms from supersonic aircraft.

*Dryden Flight Research Center, Edwards, California*

A flight experiment was recently conducted at NASA's Dryden Flight Research Center in Edwards, California, using an SR-71, an F-16XL, and a YO-3A airplane (see Figure 1) to study the propagation of sonic booms. This work is geared toward developing a high-speed civil transport (HSCT) aircraft for operational use early in the next century.

At supersonic speed, an aircraft generates numerous shock waves that emanate from such major components as the nose, canopy, inlets, wings, and vertical tails. These multiple shock waves tend to merge into a strong bow shock and a strong tail shock as they propagate through the atmosphere. At present, supercomputers and wind tunnels are used to predict the structures of these shock waves, but only within a few body lengths of the aircraft. Other computational techniques are then used to determine the propagation and merging of these shock waves down to ground level. To verify and enhance the quality of these computational propagation techniques, a data base of sonic-boom measurements at various altitudes was gathered for use by the aerospace industry, universities, and NASA research centers. These organizations will use the enhanced computational techniques in the design of the HSCT. Varying the design of an HSCT could help soften the intensities of sonic booms at ground level.

In the experiment, an SR-71 (commonly known as the Blackbird) airplane, was used to generate the sonic booms. The SR-71 flew at speeds from mach 1.25 to 1.60, altitudes from 31,000 to 48,000 ft (9.4 to 14.6 km), and gross weights from 73,000 to 118,000 lbf (325 to 525 kN) in steady, level flight. The F-16XL flew below and behind the SR-71, probing in and out of the shock waves generated by the SR-71. Sensitive pressure transducers measured the pressure changes from these shock waves. By flying the F-16XL in formation with the SR-71, the spatial resolution of the shock wave measurements was maximized and



Figure 1. These **Airplanes Were Used** to gather data on sonic booms. From top to bottom, they are the SR-71, F-16XL, and YO-3A.

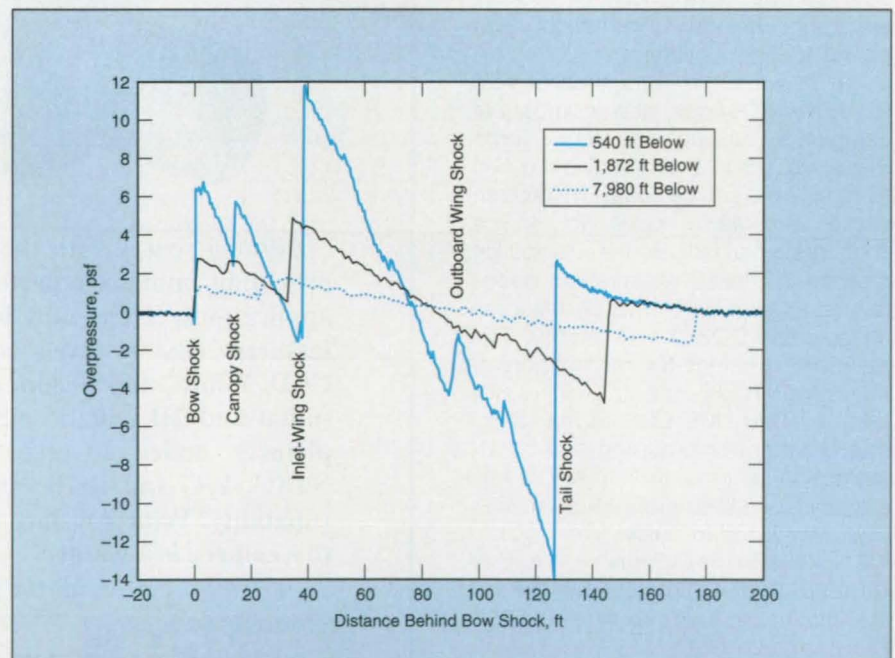

Figure 2. These **Sonic-Boom Signatures** are based on preliminary measurement data acquired by flying the F-16XL at several distances below the SR-71. The SR-71 was flying at mach 1.25 and an altitude of 31,000 ft (9.4 km).

the F-16XL gathered 105 probings during only 7 flights. These probings were measured from close to the SR-71 to more than 8,000 ft (2.4 km) below. Both aircraft carried differentially corrected carrier-phase Global Positioning System (GPS) receivers. Subtracting the position of the F-16XL from that of the SR-71 gave relative position and distance with an accuracy on the order of 1 ft (0.3 m).

A large array of sonic-boom recorders was deployed on the ground under the flight track of the SR-71 to measure the sonic-boom signatures. During eight SR-71 flights, 172 separate ground-level signatures were recorded. Sonic booms are affected by temperature, wind, humidity, and turbulence as they propagate through the atmosphere. In particular, the turbulent atmospheric layer near the ground distorts the sonic-boom signatures. To provide undistorted data at low altitude, the low-speed YO-3A airplane was flown at an altitude of 10,000 ft (3 km) to record the sonic booms above the turbulent atmospheric layer. Sensitive microphones were located at each wing tip and at the tip of its vertical tail. The YO-3A recorded 17 passes of the SR-71. Sonic booms that had first been reflected from the ground and then propagated upward to the YO-3A were also recorded. Atmospheric data were gathered for use in analysis of flight data and in computing codes for predicting the propagation of sonic booms. The flight-test techniques used in the experiment to measure pressures and relative aircraft separation accurately are also under consideration for use in other flight research unrelated to sonic booms.

Preliminary analysis of the data shows the attenuation and lengthening of the sonic boom signatures as they propagate through the atmosphere, as well as the merging of individual shock components. The mach number, altitude, and gross weight (which translates into lift) all affect the propagation characteristics. Analysis of the flight data and ground-recorded signatures continues, but preliminary results have been published in papers from the NASA High Speed Research Program's 1995 Sonic Boom Workshop.

*This work was done by Edward A. Haering, Jr., of Dryden Flight Research Center. For further information, write in 58 on the TSP Request Card. DRC-95-32*

**A**fter more than 25 years manufacturing this remarkable family of products we continue to be amazed at how our customers utilize them to improve their designs. We thought you might be interested in just a few.

# Metal Belt & Drive Tape APPLICATIONS

## Plain & Perforated Belts

Conveying, Casting,  
Imaging, Sealing,  
Timing, Positioning, Indexing,  
Vacuum Conveying, Drying

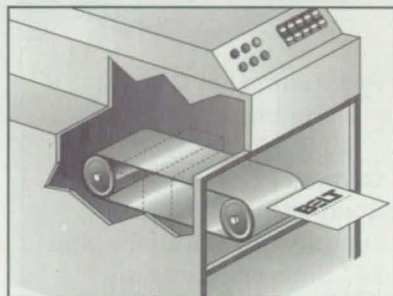

## Belts with Attachments

Packaging,  
Timed Transfer Lines,  
Lead Frame Drives,  
Automated Assembly Indexing

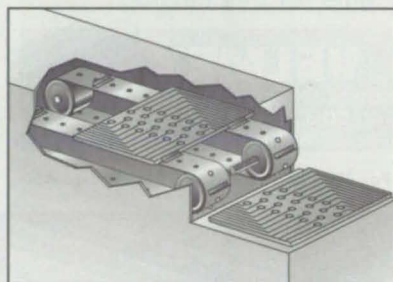

## Combination Belts

Timed Parts Nesting,  
Automated Inspection,  
Oriented Component Conveying,  
High Speed Packaging

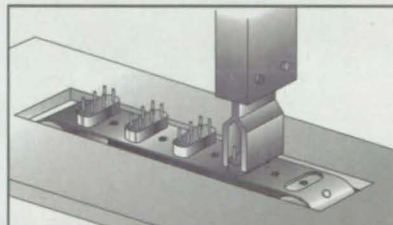

## Drive Tapes

Carriage Positioning,  
Plotter Head Drives,  
Robot Arm & Hand Manipulation,  
Optical Element Drives

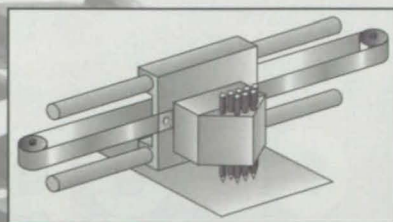

Ask us how these clean,  
precise, repeatable, strong, light  
weight products can enhance  
your designs.

**BELT**  
TECHNOLOGIES

11 Bowles Road, P.O. Box 468  
Agawam, MA 01001-0468 USA  
(413) 786-9922 Ext. 14  
FAX (413) 789-2786



**Metal Belts That Drive Productivity**

Computer controllable  
UniSlide® X-Y table

**\$1,890** complete

includes table, step motors  
and control / driver

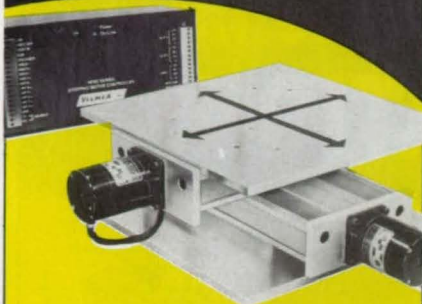

- ✓ Programmable Control plugs into any PC with RS-232C interface
- ✓ Compact & Simple Design
- ✓ Scanning and Feeding
- ✓ Testing and Manufacturing
- ✓ 747 different Models
- ✓ Send for free catalog

**VELMEX** INC.

P.O. BOX 38 • E. BLOOMFIELD, NY 14443  
TOLL FREE 800/642-6446  
IN N.Y.: 716/657-6151

For More Information Write In No. 430

## Assembling Precise Truss Structures With Minimal Stresses

Tapered pins that fit in tapered holes indicate deviations from prescribed lengths.

*NASA's Jet Propulsion Laboratory, Pasadena, California*

An improved method of assembling precise truss structures involves the use of simple devices that indicate the devi-

ations of the lengths of members (distances between node points) from the prescribed lengths. The method both

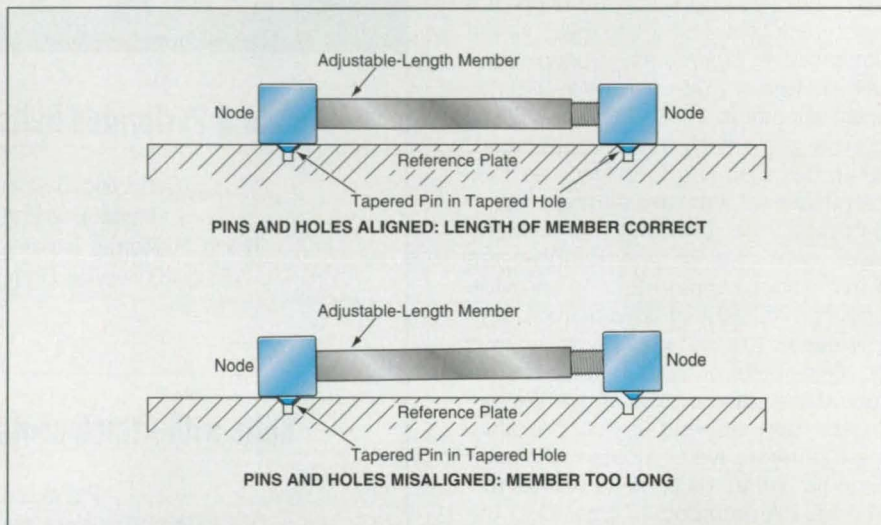

Figure 1. Misalignment Between One or More Pin(s) and Hole(s) is clearly visible as an indication that the length of the member deviates from the precise design value.

Flexibility,  
Sensitivity  
and Accuracy  
with...

# couplings

Servometer Flexible Shaft Couplings are indispensable for Robotic, Encoder, Resolver, Computer and Servomotor applications.

- Zero backlash
- Zero cyclic speed variation during 360° rotation
- Very low elastic wind-up
- Low side thrust on bearings
- Set screw or split hubs available

Call for a  
free brochure.

**SERVOMETER®**

501 Little Falls Road • Cedar Grove, NJ 07009  
(201) 785-4630 • Fax (USA): (800) 785-0756 • Fax: (201) 785-0756

helps to ensure the precision of the finished structures and to minimize residual stresses within the structures.

Previously, in the laboratory setting in which the method was devised, precision of a truss was enforced during assembly by securing selected node points of the truss to designated locations on a reference plate. Any residual compressive or tensile stresses in the members between node points were borne and thus hidden by the reference plate. Consequently, when the node points were released, these residual stresses were no longer resisted by the reference plate, and the structure became distorted.

In the improved method, the node points are not secured to a reference plate or to any other fixture that could temporarily resist and thus mask substantial residual structural stresses. In this method, conically tapered pins that are oriented facing downward are installed at measurement points on the nodes of horizontal members of the truss. Conical holes that mate with these pins are machined into a horizontal reference plate at positions that correspond to the precise design configuration of the horizontal truss members (see Figure 1). Similarly, tapered pins that face outward are installed at other mea-



urement points on the nodes of nonhorizontal members of the truss. A reference bar that functions as a reference plate for the nonhorizontal members is made by machining conical holes at the precise design distances along a square-cross-section aluminum tube.

The horizontal members are assembled on the reference plate with node pins inserted in the conical holes. The pins are thus pushed gently into the holes by the weight of the structure, but are not otherwise forced into an alignment that places the members under substantial stresses. Similarly, the reference bar is held against the nodes at the ends of a nonhorizontal member, so that the pins are pushed gently into the mating holes (see Figure 2).

When the length of any member deviates from the design value by more than 0.005 in. (0.13 mm), the misalignment between the pin and hole at either or both ends of the member is clearly visible. The lengths of the members can be adjusted until the structure is in the required configuration, as indicated by alignment of all pins with their reference holes. Thereafter, the structure retains its precise configuration because unlike in the previous method, the completion of the assembly and alignment process

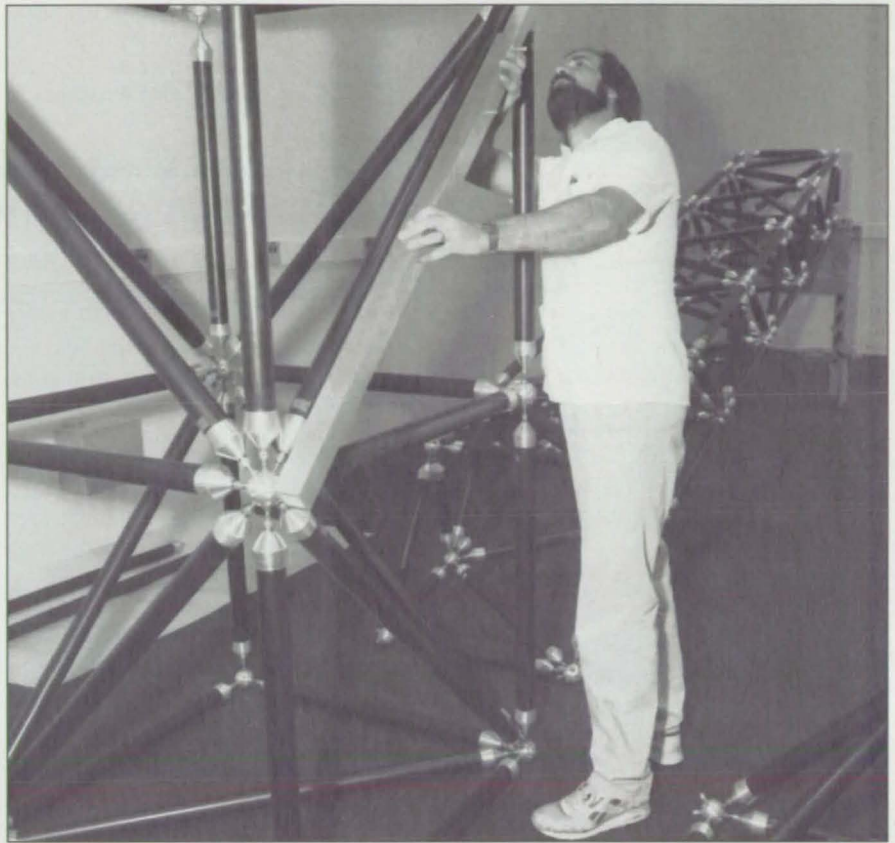

Figure 2. The Technician Holds the Reference Bar, which functions similarly to the reference plate shown in Figure 1.

## Solid Modeling Simplified

**CAD without clutter or complexity.** Intergraph's **SOLID EDGE** gives you all of the capability and none of the confusion of traditional CAD systems. High-performance mechanical modeling in the comfortable, familiar Microsoft Windows® environment lets you spend more time designing, and less time operating a CAD system.



**Next-generation interactive design tools.** **SOLID EDGE** helps you design faster with innovative, intuitive mechanical modeling that is easy to learn and use. If you want to shorten learning curves, improve productivity, and reduce training costs, the clear choice is **SOLID EDGE**.

For the ease-of-use advantage, call **800-546-5550** or reach us on the Internet at <http://www.intergraph.com/mech/solidedge.shtml>.

**INTERGRAPH**  
SOFTWARE SOLUTIONS



**INTERGRAPH**  
**SOLID EDGE**

Intergraph and the Intergraph logo are registered trademarks and Solid Edge is a trademark of Intergraph Corporation. Microsoft and Windows are registered trademarks of Microsoft Corporation. Copyright 1995 Intergraph Corporation.

# TECHNOLOGY ACCESS REPORT

OUR MISSION...

... To help  
you speed  
innovation  
from lab  
to market



**Q.** Have you wanted to explore federal and university technologies?

**Q.** Are you curious about how much your own technologies would fetch?

**Q.** Would you like to know the prospects for R&D-based firms after the 104th Congress?

**Q.** Submerged in the day-to-day, do you ever long for a "periscope" (and the time) to scan the technology horizon?

**A.** If you answered yes to any of these questions, then you'll profit from **Technology Access Report**—for eight years the only independent, practical newsletter devoted to the tech transfer process.

**YES!** Send me twelve 16-24pp monthly issues packed with leads, opportunities and advice. Upon payment, send me your "Key Resource List" and a handsome padded binder, all for just \$397—**\$100 off the regular price.** Satisfaction guaranteed or all my money back. (Outside N. America, add \$90 for air mail delivery.)

Name \_\_\_\_\_

Title \_\_\_\_\_

Organization \_\_\_\_\_

Address \_\_\_\_\_

City \_\_\_\_\_

State \_\_\_\_\_ Zip \_\_\_\_\_

Phone ( ) \_\_\_\_\_

Fax ( ) \_\_\_\_\_

## TECHNOLOGY ACCESS

16 Digital Dr., Suite 250  
Novato, CA 94949-5760

800/733-1556 (415/883-7600)

or fax to 415/883-6421

E-mail: info@techaccess.com

NASA

does not involve a substantial alteration in the state of stress in the structure.

This work was done by Lee F. Sword of Caltech for **NASA's Jet Propulsion**

**Laboratory.** For further information, write in 106 on the TSP Request Card. NPO-19114

## Mechanism Attaches to Special Fixture

Hooks and bumper pads hold the device in place.

Lyndon B. Johnson Space Center, Houston, Texas

The figure illustrates a mechanism designed for attachment to a special fixture on a round structural member. In the original application, the special fixture is a striker bar, the round structural member lies at the end of a remote manipulator on the space shuttle, and the mechanism is used to attach a foot restraint for use by an astronaut during extravehicular activity. On Earth, similar mechanisms and fixtures with suitably modified dimensions might be useful for temporary attachment of various items (e.g., safety harnesses) to structures or machines.

The mechanism is initially brought into approximate alignment with the striker bar or other fixture. The knob on top of the mechanism is turned to pull the hooks into firm contact with the

striker bar, thereby bringing the bumper pads into firm contact with the bearing surfaces on the structural member near the brackets that support the striker bar. The item to be attached to the structural member (the foot restraint in the original application) is attached via a socket in the mechanism.

This work was done by Ronald James Zaguli of **Johnson Space Center.** For further information, write in 21 on the TSP Request Card.

This invention is owned by NASA, and a patent application has been filed. Inquiries concerning nonexclusive or exclusive license for its commercial development should be addressed to the Patent Counsel, Johnson Space Center; (713) 483-4871. Refer to MSC-21885.

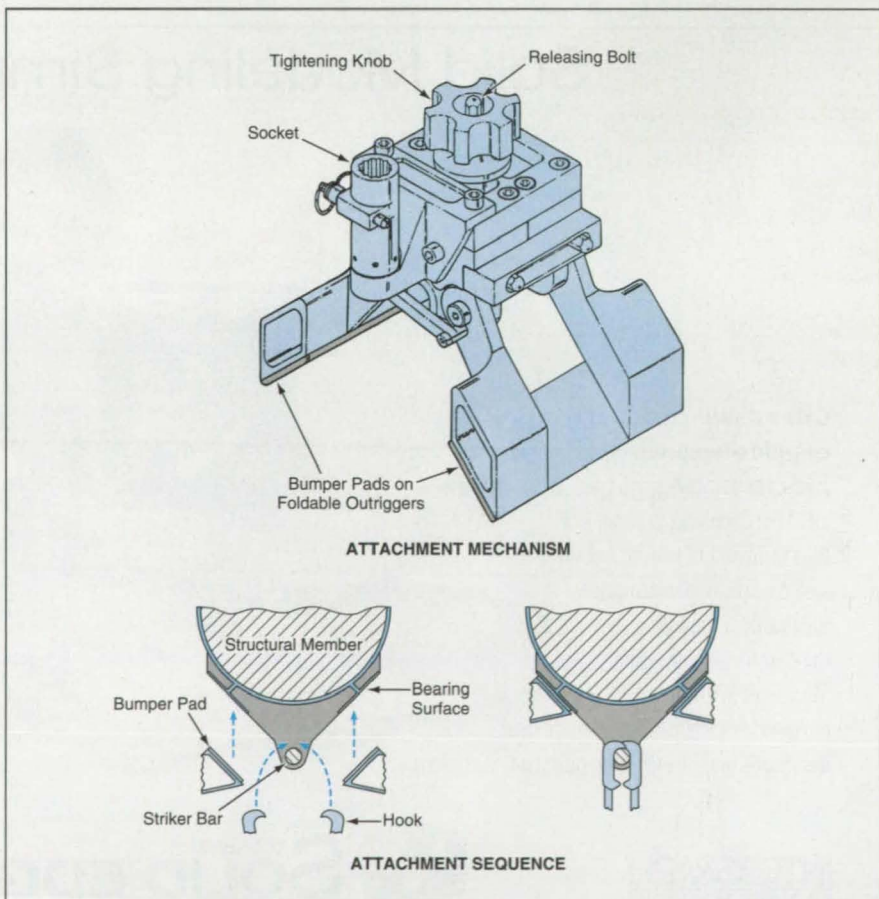

The **Attachment Mechanism** grasps the striker bar with hooks, pulling itself inward so that its pads press against the structural member.

# Rod Has High Tensile Strength and Low Thermal Expansion

Thoriated tungsten is turned and threaded to form an extension rod for a gap gauge.

*Marshall Space Flight Center, Alabama*

A thoriated tungsten extension rod has been fabricated to replace a stainless-steel extension rod attached to a linear variable-differential transformer in a gap-measuring gauge. The extension rod and adjacent parts of the gauge are required to withstand temperature as high as 1,000 °F (≈540 °C) and differential pressure as high as 2.2 kpsi (≈15 MPa). (In the original application, the gauge is used to measure a gap in a rocket motor.) Thoriated tungsten was chosen over stainless steel and other candidate rod materials because it offers a more nearly optimum combination of properties including, most notably, a low coefficient of thermal expansion [ $2.5 \times 10^{-6}/^{\circ}\text{F}$  ( $4.5 \times 10^{-6}/^{\circ}\text{C}$ )], high tensile strength [590 kpsi (≈4.1 GPa)], nonmagnetism, and some ability to withstand shock accelerations.

The rod is made from thoriated tungsten TIG (Tungsten Inert Gas) welding-electrode stock 0.125 in. (≈3.2 mm) in diameter, containing 2 percent thoriated tungsten. The stock is held in a drill

guide on a lathe, where it is turned at a speed of 478 r/min, with a removal rate of 0.003 in. (≈0.08 mm) per revolution, to machine it down to a diameter of 0.060 in. (≈1.5 mm). One end of the rod is then threaded (see figure) at 80 threads per inch (≈3.1 threads per millimeter). The threading operation is performed with the help of a special threading guide at a machine speed of 125 r/min, using a 90° end mill rotating at 400 r/min to form the notch, which is cut at 0.0005 in. (≈0.013 mm) per pass. Special care must be taken in these machining operations: small deviations from the recommended machining speeds and feeds cause shattering of the tungsten rod into several pieces.

*This work was done by D. E. Smith, R. L. Everton, E. Howe, and M. O'Malley of Thiokol Corp. for Marshall Space Flight Center. For further information, write in 43 on the TSP Request Card.*

*Inquiries concerning rights for the commercial use of this invention should be addressed to the Patent Counsel,*

*Marshall Space Flight Center; (205) 544-0021. Refer to MFS-28891.*

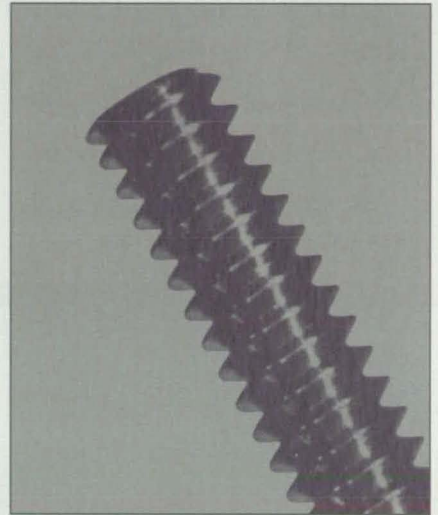

**Threads Are Formed** on the end of the thoriated tungsten rod by machining with special fixtures and a carefully chosen combination of speeds and feeds.

## Freedom of Assembly

### CAD for assembly.

Intergraph's **SOLID EDGE** goes beyond the part modeling approach of traditional CAD systems to improve assembly design productivity and quality. With specialized assembly design tools, you can model part-to-part relationships, analyze interference, and experiment with assembly configurations.



### Design within the assembly.

With **SOLID EDGE**, you build a digital assembly prototype that helps you identify and eliminate design problems. Unique assembly navigation and management aids help you move quickly through large models, select the environment for your design task, and collaborate with assembly project teams. You can even build assemblies using parts from other CAD systems!

**INTERGRAPH**  
SOFTWARE SOLUTIONS



**INTERGRAPH**  
**SOLID EDGE**

Intergraph and the Intergraph logo are registered trademarks and Solid Edge is a trademark of Intergraph Corporation. Copyright 1995 Intergraph Corporation.

For the assembly design advantage,  
call **800-546-5550**  
or reach us on the Internet at  
[http://www.intergraph.com/  
mech/solidedge.shtml](http://www.intergraph.com/mech/solidedge.shtml).



## Jet-Engine Exhaust Nozzle With Thrust-Directing Flaps

Large attitude-control forces are produced, with minimal loss of performance.

*Langley Research Center, Hampton, Virginia*

An experimental convergent/divergent jet-engine exhaust nozzle has a cruciform divergent passage containing flaps that can be moved to deflect the flow of exhaust in either or both planes perpendicular to the main fore-and-aft

In the nondeflecting ("cruise" or "unvectored") mode of operation, the flaps are arranged symmetrically to form a convergent/divergent exhaust nozzle. In the single-axis deflecting ("thrust-vectoring") mode of operation (see Figure 2), the

internal-thrust and mass-flow performances competitive with those of previous nozzles. The thrust performance of the cruciform nozzle with single-axis thrust vectoring was 1 to 2 percent lower than the thrust performances of other

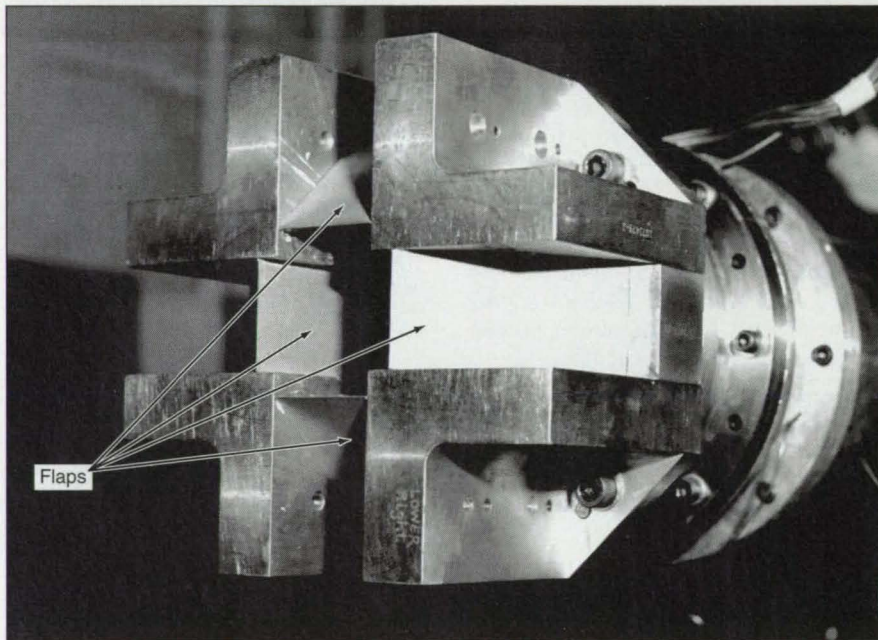

Figure 1. The **Cruciform Nozzle** is shown here mounted on a test stand, with the diverging flaps positioned symmetrically for "unvectored" (nondeflecting) operation.

axis of undeflected flow. This nozzle is a prototype of thrust-vector-control nozzles that would be installed in advanced, high-performance airplanes to provide large pitching (usually, vertical) and yawing (usually, horizontal) attitude-control forces independent of the attitude-control forces produced by the usual aerodynamic control surfaces. Other nozzles have been considered for this purpose in recent years, but their combined pitch/yaw thrust-vector capabilities have been limited by physical interference between flaps and by asymmetries.

The nozzle contains four sets of hinged convergent and divergent flaps positioned to form the top, bottom, left, and right sides of the nozzle. Four L-shaped corner pieces form channels within which the divergent flaps are moved to obtain the desired deflection (see Figure 1).

upper and lower (or the right and left) diverging flaps are both turned in the same direction to create a component of thrust in the vertical (or horizontal, respectively) plane of deflection. In the two-axis thrust-vectoring mode, both pairs of opposing flaps are deflected simultaneously to create both vertical and horizontal components of thrust. To prevent physical interference between adjacent flaps during large simultaneous deflections in both planes, the two pairs of convergent/divergent flaps for either the horizontal or the vertical plane are shifted laterally with respect to the main axis of the nozzle: This feature is essential to the capability to produce large, essentially equal components of thrust along both axes perpendicular to the main fore-and-aft axis.

In experiments, in the unvectored mode, the cruciform nozzle exhibited

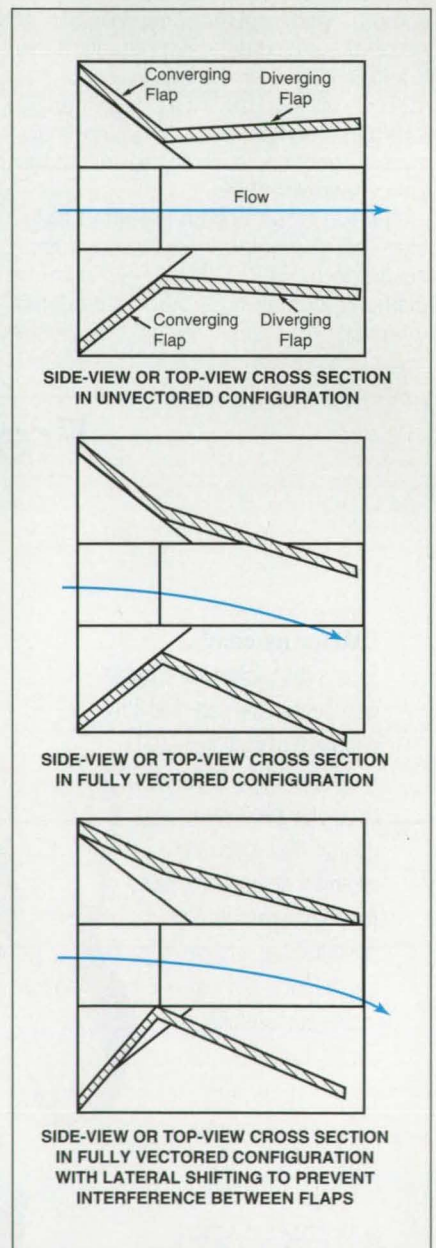

Figure 2. The **Flaps Are Positioned and Oriented** to control the direction of flow of the exhaust and thus the direction of thrust.

comparable two-dimensional convergent/divergent nozzles; loss being attributed to splitting of the flow. Additional loss of thrust was observed in two-axis

thrust vectoring, and was attributed to some turning of supersonic flow.

This work was done by David J. Wing of **Langley Research Center**. For fur-

ther information, **write in 34** on the TSP Request Card. LAR-14692

## High-Current Rotating Contactor

Marshall Space Flight Center, Alabama

A rotating electrical contactor capable of carrying 1,000 amperes of current has been built for use in rotating a large workpiece in an electroplating bath. Electrical contact is made by use of 24 automotive starter motor brushes adapted to match the inside diameter of a

shell electrode. This contactor replaces a previous contactor in which current was conducted via a stationary electrode and a shell electrode via a mercury bath. After nearly 500 h of use, no signs of degradation of the contactor were observed.

This work was done by David W. Hagan and Edwin D. Wolff of Rockwell International Corp. for **Marshall Space Flight Center**. For further information, **write in 90** on the TSP Request Card. MFS-30063

## Aqueous-Spray Cleaning System

Marshall Space Flight Center, Alabama

A simple aqueous-spray cleaning system with overall dimensions comparable to those of a large kitchen refrigerator has been constructed for use in cleaning hardware in a shop. If mass-produced, the system would likely be competitive with similar currently available commercial aqueous-spray cleaning systems that are sold for about \$20,000 (1995

prices). The system is made of commercially available parts and materials; the only unusual major part is its spray cabinet, which contains spinner-type sprayers and is a surplus unit that was originally used for steam cleaning. The system incorporates an economical cleaner-and-rinse-recycling subsystem, as well as a programmable logic-con-

troller device for either manual or automatic operation.

This work was done by Gene E. Morgan, William S. Hoult, and Gareth L. Simpson of Rockwell International Corp. for **Marshall Space Flight Center**. For further information, **write in 52** on the TSP Request Card. MFS-30074

## Open, Plug-and-Play CAD

**CAD without boundaries.** Intergraph's **SOLID EDGE** breaks the barriers between CAD and your other software.

It works hand-in-hand with spreadsheets, word processors, e-mail, and CAD/CAM/CAE programs.

With **SOLID EDGE** you can take advantage of a seamless, productive desktop for mechanical design that brings together all of your computer-aided tools.



**A new way to integrate.**

**SOLID EDGE** brings you revolutionary plug-and-play integration with hundreds of business, technical, and personal productivity applications. With simple drag-and-drop, cut-and-paste techniques, you can

readily link programs and freely share data. It's an entirely new paradigm for CAD integration that can dramatically change the way you automate design.

For the plug-and-play advantage, call **800-546-5550**

or reach us on the Internet at <http://www.intergraph.com/mech/solidedge.shtml>.

**INTERGRAPH**  
SOFTWARE SOLUTIONS

**INTERGRAPH**  
**SOLID EDGE**

Intergraph and the Intergraph logo are registered trademarks and Solid Edge is a trademark of Intergraph Corporation. Copyright 1995 Intergraph Corporation.



### Ultrasonic Inspection of Welds on Tube Fittings

An ultrasonic scanner is designed for the specific items to be inspected.

*Marshall Space Flight Center, Alabama*

A scanning ultrasonic apparatus is designed for use in nondestructive inspection of electron-beam welds between a heat-exchanger tube and its end fittings. The apparatus (see figure) includes an ultrasonic probe, a scanning mechanism, ultrasonic-signal-generating and -processing circuits, and computers. It is not necessary to immerse any part of the apparatus or tube/fitting assembly in water during the ultrasonic inspection.

The scanning mechanism is designed to be mounted on the fitting to be inspected. The mechanism inserts the probe axially into the fitting, rotates the probe 360°, and indexes the probe axially to scan the entire weld. The output ultrasonic-test signals can be displayed on a computer to reveal defects. To aid in identification of defects, signals obtained from the inspected fitting can be compared with those from a standard

fitting that contains simulated defects in the form of notches and holes of various sizes. The scanning function provides data on the positions of flaws, which can then be reworked as needed.

*This work was done by Arjun N. Ray and John L. Nummelin of Rockwell International Corp. for Marshall Space Flight Center. For further information, write in 72 on the TSP Request Card. MFS-29848*

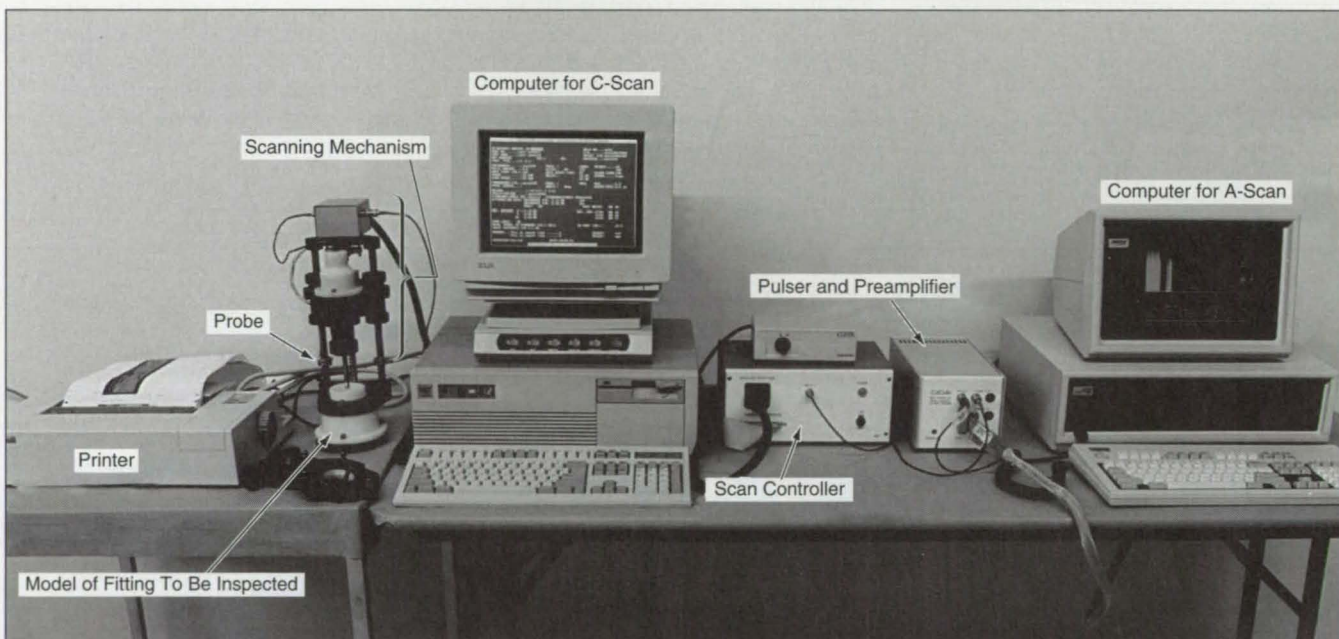

The **Ultrasonic-Testing Apparatus** is designed specifically for use in inspecting welds in tube fittings. The scanning mechanism is shown here attached to a model of a fitting on the table; in a real inspection, it would be attached to a fitting welded on the end of a tube.

### Push/Push Fastener

Pushing from one side tightens the fastener; pushing from the other side loosens it.

*Lyndon B. Johnson Space Center, Houston, Texas*

The figure illustrates a modified version of a Nylatch (or equivalent) commercial quick-connect/quick-disconnect fastener for joining flat panels. In the original version, the fastener is tightened or loosened by pushing or pulling, respectively, on a knob on one side (shown as left) of the joined panels. In the mod-

ified version, the fastener is tightened by pushing on the knob on one side and loosened by pushing on the knob on the other side.

The push/push operation of the modified fastener is advantageous because grasping and pulling a small knob can be difficult, especially in cold or other-

wise hostile environments where gloves must be worn, in underwater operations, or if the person is handicapped. Of course, to be able to both tighten and loosen the modified fastener, one must have access to both sides.

Before the fastener is actually used to join the two panels, preliminary opera-

tions are performed: (1) Different sized holes are made in the panels to be joined; (2) The grommet is popped into the hole in the removable panel only; (3) The threaded end of the plunger is inserted through the grommet and threaded into the right knob. The panels are put together by inserting the right knob through, and the grommet into, the hole in the fixed panel, thus providing a "soft dock." Note that the diameter of the right knob is slightly less than the diameter of the larger hole in the fixed panel. The dimensions of the holes, plunger, and grommet are chosen to provide a loose fit to accommodate any misalignments that might be present during insertion and before tightening.

To tighten the fastener, joining the panels securely, one pushes the left knob rightward (toward the panels), causing the plunger to expand the grommet against the edges of the hole in the fixed panel. To loosen the fastener, one simply pushes the right knob leftward (again, toward the panels).

This work was done by Steven A. Jackson of McDonnell Douglas Corp. for Johnson Space Center. For further information, write in 82 on the TSP Request Card.

This invention is owned by NASA, and a patent application has been filed. Inquiries concerning nonexclusive or exclusive license for its commercial

development should be addressed to the Patent Counsel, Johnson Space Center; (713) 483-4871. Refer to MSC-22329.

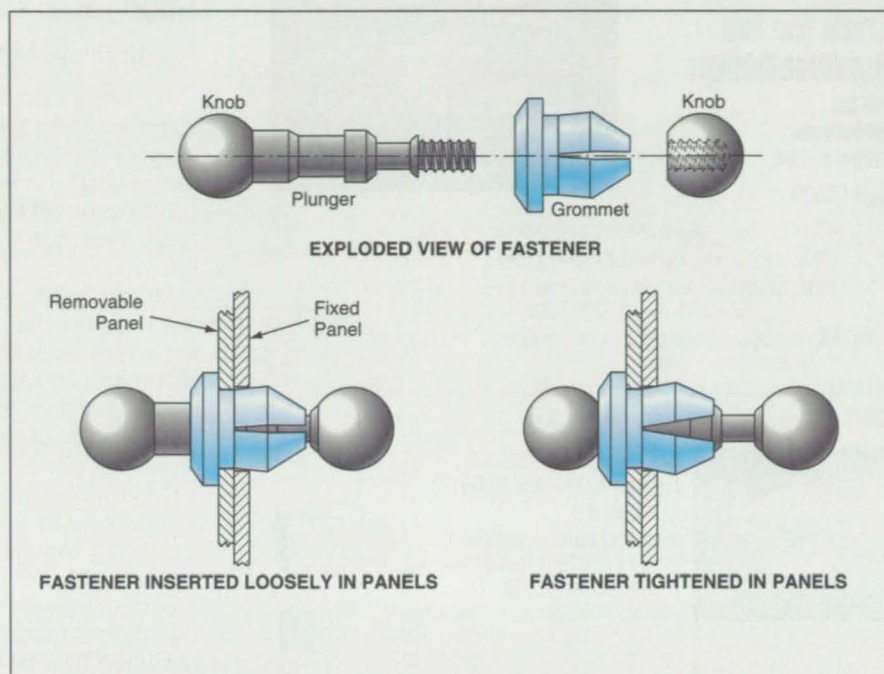

The Modified Fastener is tightened by pushing the left knob rightward and loosened by pushing the right knob leftward.

## CAD for the Leading Edge

### Next-generation mechanical CAD.

Intergraph's **SOLID EDGE** brings you the productivity and time-to-market advantages of leading-edge mechanical design technology. Innovative assembly design tools. A new standard for power and ease of use. Revolutionary plug-and-play software integration.

**INTERGRAPH**  
SOFTWARE SOLUTIONS

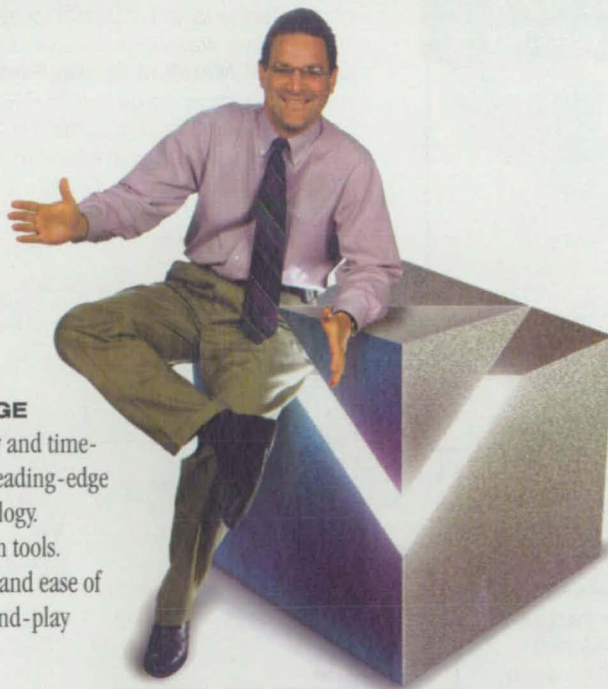

**INTERGRAPH**  
**SOLID EDGE**

### Leading-edge value.

**SOLID EDGE** delivers breakthrough performance at a surprisingly affordable price. Built on advanced capabilities of the world's most popular, productive, and cost-effective computing environment, **SOLID EDGE** is an exceptional value that can help you gain and keep a competitive edge.

For the leading edge advantage, call 800-546-5550 or reach us on the Internet at <http://www.intergraph.com/mech/solidedge.shtml>.

Intergraph and the Intergraph logo are registered trademarks and Solid Edge is a trademark of Intergraph Corporation. Copyright 1995 Intergraph Corporation.

# PC Data Acquisition Solutions

**VISUAL  
DESIGNER™**  
BEYOND PROGRAMMING...

Create Your Data  
Acquisition Solutions

For Test,  
Measurement,  
Control & More.

USER FRIENDLY -



- SELECT** - Application Function Blocks then Drag & Drop
- CONNECT** - Function Blocks to Complete Custom FlowGrams
- ACQUIRE** - Choose Run and your Data Acquisition is Up and Running in RECORD TIME

**POWERFUL** - Analog and Digital I/O, Data Streaming, Real Time Displays, Controls and Interfaces

**FLEXIBLE** - Supports Infinite Number of Custom Data Acquisition Applications

**SAVES** - Development Time and Reduces Costs



**NEW—Free CD Evaluation Package**

Try Your Application Today!  
Call (800) 885-9911

Intelligent Instrumentations, Inc.  
6550 E Bay Colony Dr. MS130  
Tucson, Arizona 85706

Sales and Information: 800-685-9911  
Technical Support: 520-573-3504  
FAX: 520-573-0522  
International Fax: 520-573-9671

<http://www.instrument.com>



**INTELLIGENT  
INSTRUMENTATION™**

A Burr-Brown Company



Visual Designer™, Intelligent Instrumentation, Inc., Windows®, Microsoft Corporation.

For More Information Write In No. 419

## Thermal-Ribbon RTD's fast response surface sensing



S17422  
0.1 second response

S17624 Thin film RTD

S651 Miniature platinum RTD

Thin, flexible resistance temperature detectors • Wire wound or thin-film • Pt, Cu, Ni, Ni-Fe curves • 0.1 second time response • Rugged laminated construction • -200 to 220°C range • Many sizes & styles in stock

Stable, accurate, dependable measurement • Install with self-stick backing, tapes, or cements • Avionics • Process lines • Medical devices • Aircraft windows • Stator windings • Thermal processing equipment

**MINCO** PRODUCTS, INC.

7300 Commerce Lane • Minneapolis, MN 55432-3177 U.S.A.  
Telephone: (612) 571-3121 • FAX: (612) 571-0927

## Adhesion Casting in Low Gravity

Stronger and lighter materials could be made.  
Marshall Space Flight Center, Alabama

Adhesion casting in low gravity has been proposed as a technique for making new and improved materials. The advantages of low-gravity adhesion casting, in comparison with adhesion casting in normal Earth gravity, would come from better control over, and greater uniformity of, the thicknesses of the liquid films that form on and adhere to solid surfaces during casting.

In low gravity, the magnitudes of capillary forces would be much greater than those of gravitational forces, so that capillary effects would be magnified. This enhancement of capillary action could be exploited to achieve more nearly uniform liquid coating on solid surfaces and/or more nearly uniform liquid impregnation of porous solids or beds of solid particles. It should be possible to exploit these effects to achieve greater strength-to-weight ratios in adhesion-cast materials.

A conceptual generic low-gravity adhesion-casting apparatus would include a controlled-temperature crucible and a reservoir of the liquid to be cast. A porous substrate, chemically compatible with the liquid, would be immersed in the liquid in the crucible, then removed with the liquid adhering to it. The liquid would then be polymerized or otherwise solidified by thermal, chemical, or optical means.

An experiment that demonstrated some of the relevant physical effects was performed in an airplane flying on repeating parabolic arcs to simulate low gravity ( $\approx \pm 10^{-2}g$ , where  $g$  = normal gravitational acceleration on the Earth) for about 25 seconds alternating with double Earth gravity (2g) for about 20 seconds and normal Earth gravity (1g) for about 20 seconds. In this experiment, a soap froth was used to illustrate the effects of capillary and gravitational forces (see figure).

This work was done by David A. Noever and Raymond J. Cronise of Marshall Space Flight Center. For further information, write in 46 on the TSP Request Card.

Inquiries concerning rights for the commercial use of this invention should be addressed to the Patent Counsel, Marshall Space Flight Center; (205) 544-0021. Refer to MFS-28908.

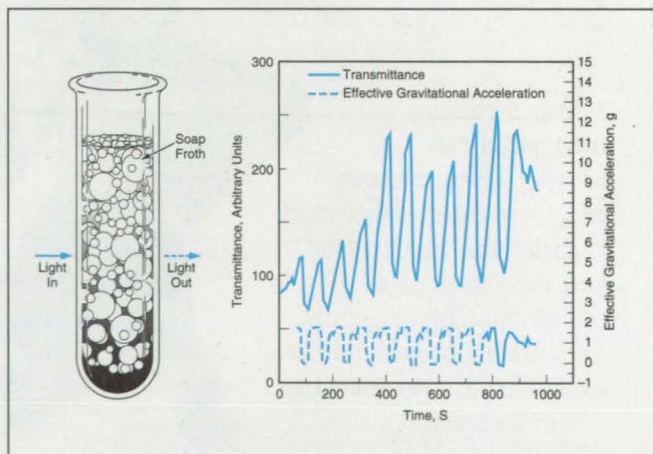

The Spectral Transmittance of the soap froth was measured along with the effective gravitational acceleration during cycles of alternating low and high simulated gravity. During low gravity, capillary forces predominated, causing the liquid to become more nearly evenly distributed in the foam. During high gravity, excess fluid was drained, resulting in coarsening of the foam, with consequent increase in the amount of light transmitted through the foam.





## Fast Neural Solution of a Nonlinear Wave Equation

The numerical solution by a simulated neural network closely approximates the exact solution.

NASA's Jet Propulsion Laboratory, Pasadena, California

A neural algorithm for the simulation of a class of nonlinear wave phenomena has been devised. The algorithm numerically solves a special one-dimensional case of the Korteweg-deVries equation, which is a nonlinear wave equation that describes gravity waves like one-dimensional shallow water waves with finite amplitudes. The algorithm is intended to be executed rapidly by a neural network implemented as a charge-coupled-device/charge-injection device, very-large-scale integrated-circuit analog data processor of the type described in "CCD/CID Processors Would Offer Greater Precision" (NPO-18972), NASA Tech Briefs, Vol.19, No.10 (Oct. 1995), page 38.

The special one-dimensional Korteweg-deVries equation in question is  $u_t + 6uu_x + u_{xxx} = 0$ , where  $u$  is the amplitude at time  $t$  and position  $x$ , and the subscripts represent partial differentiation with respect to the noted variables. This equation was chosen because its exact solution is known; therefore, one can determine the accuracy of the numerical solution produced by the neural network. The exact solution is

$$u(x,t) = 2k^2 \operatorname{sech}^2(kx - 4k^3t + \eta_0)$$

where  $k$  and  $\eta_0$  are constants, with  $k > 0$ . This solution represents a solitary wave of amplitude  $2k^2$  initially located at  $x = -\eta_0/k$ , moving with velocity  $4k^2$ .

The derivation of the algorithm begins with the reformulation of the special one-dimensional Korteweg-deVries equation into a discretized form with  $2N$  points at equal intervals along the  $x$  axis, a pseudospectral (quasi-Fourier-transform) representation of the spatial dependence, and a leap-frog discretized approximation of the temporal derivative. The equation is reformulated further into a matrix-vector form suitable for computation on the CCD/CID neural network.

The heart of the neural network is a matrix of CCD/CID cells that performs matrix-vector multiplication. To recapitulate from the noted prior article: One of the gates of each cell is connected by a

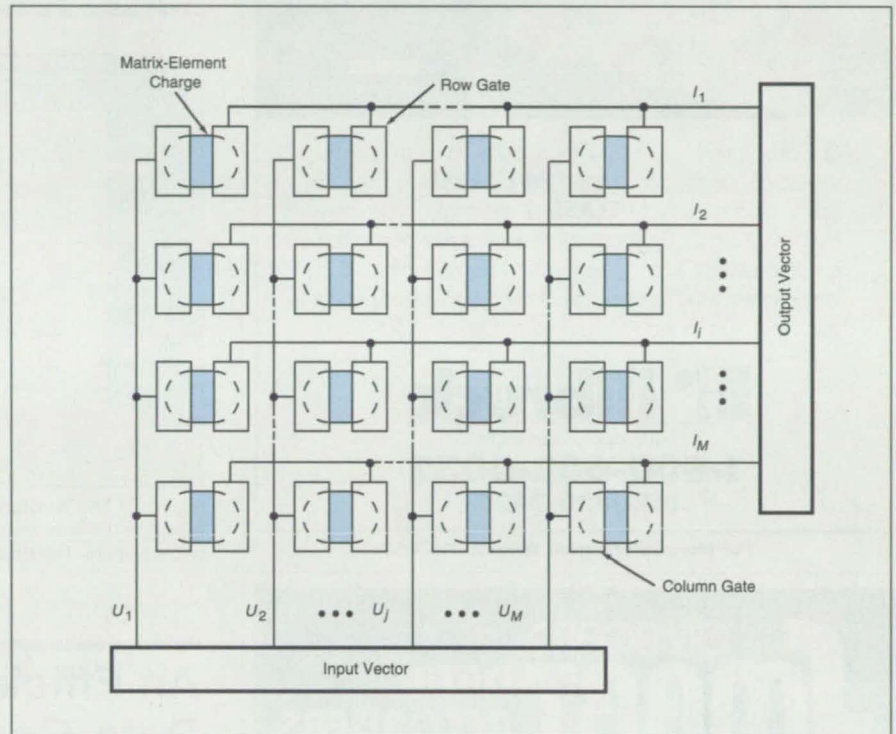

Figure 1. The CCD/CID Processor performs matrix-vector multiplication in one clock cycle.

column electrode to the corresponding gates of all other cells in the same column. Similarly, another gate of the cell is connected by a row electrode to the corresponding gates of all other cells in the same row. The charge stored beneath the row and column gates of each cell encodes the matrix element represented by the cell, while the column and row electrodes represent the input vector and the output vector, respectively. In its most basic configuration, shown in Figure 1, such a circuit computes the product of a binary input vector and an analog matrix of charge. The computation done by each cell in the matrix is a multiplication and accumulation in which the matrix-element charge,  $Q_{ij}$ , is multiplied by a binary input vector element,  $U_j$ , encoded on the column line and this product is summed with other products in the same row to form  $I_i$ . Multiplication by a binary number is equivalent to adding or not adding the charge at a particular matrix element to

its associated row line. Since all column electrodes are pulsed at the same time and the associated changes in voltage are then capacitively summed on the row lines in parallel, the entire matrix-vector multiplication is accomplished in one clock cycle. Many improvements have been incorporated into this basic structure, the most important being the ability to handle digital input and output. A prototype circuit of  $256 \times 256$  elements is expected to handle  $10^{12}$  arithmetic operations per second per bit of precision.

Pending completion of the CCD/CID circuit, the neural algorithm was implemented as a computer program. For this purpose, the spatial region  $[-20, +20]$  was divided into 64 intervals, and the initial condition (at  $t = 0$ ) was chosen to be that of a solitary wave located at  $x = 0$  and moving with a speed of 3.2 spatial intervals per unit time. The integration time step was chosen to be 0.005. As shown in Figure 2, the numerical results

**It doesn't take a rocket scientist to control noise. No offense.**

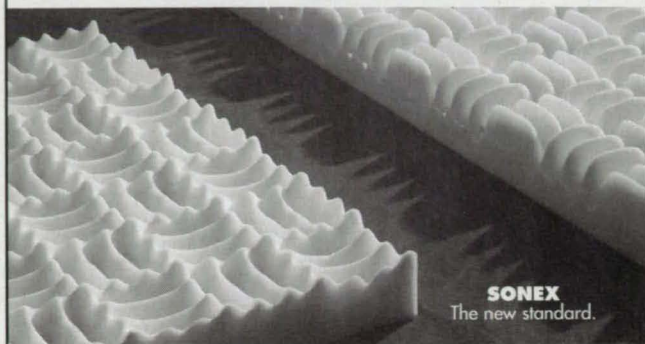

**SONEX**  
The new standard.

illbruck's family of SONEX products is setting new standards, with completely **FIBER-FREE** acoustical solutions in exclusively **CLASS 1** materials. Our new and improved SONEX combines exceptional absorption properties with Class 1 fire-resistant materials for the safest environment. You'll get peace of mind, as well as peace and quiet. Send today for a free brochure.

**illbruck**  
Minneapolis, Minnesota  
**1-800-662-0032**  
**(612)520-3620**

For More Information Write In No. 423

closely approximated the exact solution.

This work was done by Jacob Barhen and Nikzad Toomarian of Caltech for **NASA's Jet Propulsion Laboratory**. For further information, **write in 56** on the TSP Request Card.

In accordance with Public Law 96-517, the contractor has elected to retain title to this invention. Inquiries concerning rights for its commercial use should be addressed to:

William T. Callaghan, Manager  
Technology Commercialization  
Jet Propulsion Laboratory  
4800 Oak Grove Drive  
Pasadena, CA 91109

Refer to NPO-18906 volume and number of this NASA Tech Briefs issue, and the page number.

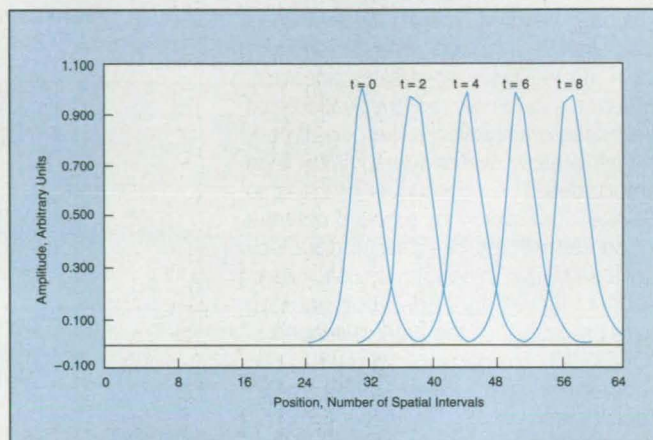

Figure 2. The Numerical Solution obtained by the neural simulation overlaps the exact solution so closely that one cannot distinguish the two solutions from each other on this plot.

## ON BOARD SMART DATA RECORDERS

Compact, PC-programmable, acceleration data recorders for multi-channel, multi-event field data acquisition. Self-contained 1 & 3-axis, and 9-channel units offering up to 24MB data storage. Fully user-configurable digitization (30Hz - 24kHz), triggering, and signal conditioning allow for truly "smart" field operation. Recorder setup and data playback & analysis on your PC! Battery powered for self-contained operation for **30-60 days!**



- VEHICLE VIBRATION
- ACCEL: DECEL PROFILES
- CRASH RECORDING
- SUSPENSION VIBRATION
- ENGINE VIBRATION

- ORV SHOCK & VIB LEVELS
- CRASH DUMMY TESTS
- SHOCK ABSORBER TESTING
- RIDE QUALITY
- SHIPMENT MONITORING

If you're looking for turn-key, integrated & calibrated sensing and recording systems for on-board, 3-D acceleration measurements:

**IST** Instrumented  
Sensor  
Technology  
4704 Moore St., Okemos, MI 48864

CALL, WRITE, OR FAX:  
(517) 349-8487  
FAX (517) 349-8469

## An Efficient Variable-Length Data-Compression Scheme

Either ARH or Huffman coding is chosen, depending on the characteristics of the data stream.

NASA's Jet Propulsion Laboratory,  
Pasadena, California

An adaptive variable-length coding scheme for compression of a stream of independent and identically distributed source data involves the use of either a Huffman code or an alternating run-length Huffman (ARH) code, depending on the characteristics of the data. This scheme enables the efficient compression of the output of a lossless or lossy precompression process, with speed and simplicity greater than those of older coding schemes developed for the same purpose. In addition, this scheme is suitable for parallel implementation on hardware with a modular structure, provides for rapid adaptation to a changing data source, is compatible with block orientation to alleviate memory requirements, ensures efficiency over a wide range of entropy, and can be easily combined with such other communication schemes as those for containment of errors and for packetization.

The need for schemes of this type arises in connection with low-entropy sources. In a typical data-compression application, one data symbol often occurs much more frequently than others do. For example, in predictive coding, the error samples tend to be small, and in transform-based coding systems, the

signal energy is usually more concentrated in the low-frequency components. In each of these cases, the data are quantized before compression, and the quantized data often constitute a low-entropy data source consisting of long runs of zeros interspersed with small nonzero values. The basic problem in this situation is how to achieve efficient coding of a low-entropy data source; that is coding at a rate less than 1 bit per sample. A well-known drawback of Huffman coding in this situation is that while the entropy may be near 0, the rate of a Huffman code can never be less than 1 because the Huffman code assigns a code word to every source symbol.

In an ARH code, one Huffman code represents the lengths of runs of the dominant symbol, while another Huffman code represents the remaining symbols. This run-length code enables the representation of the instances of the most frequent symbol using, on the average, less than one bit per sample. In ARH coding, the redundancy approaches zero as the probability ( $P$ ) of the most frequent symbol approaches 1.

In the present method, the choice of which code (Huffman or ARH) to use in a given application is dictated by a determination of which is more efficient, given the probability-of-occurrence characteristics of the data source. This determination can be made by use of the following four criteria derived from a theoretical analysis based on fundamental principles of Huffman coding:

1. If  $P < 1/3$ , then Huffman coding is more efficient.
2. If  $P$  lies between  $1/3$  and  $2/5$ , then the efficiency of ARH coding is less than or equal to that of Huffman coding, depending on the probability distribution of symbols in the data source.
3. If  $P$  lies between  $2/5$  and  $(5^{1/2} - 1)/2$  [the reciprocal ( $\approx 0.618$ ) of the "golden ratio" known since ancient times], then ARH and Huffman coding are equally efficient.
4. If  $P > (5^{1/2} - 1)/2$ , then ARH coding is more efficient.

The figure illustrates the results of the theoretical analysis and application of the criteria to a test case.

This work was done by Kar-Ming Cheung and Aaron B. Kiely of Caltech for NASA's Jet Propulsion Laboratory. For further information, write in 13 on the TSP Request Card. NPO-19576

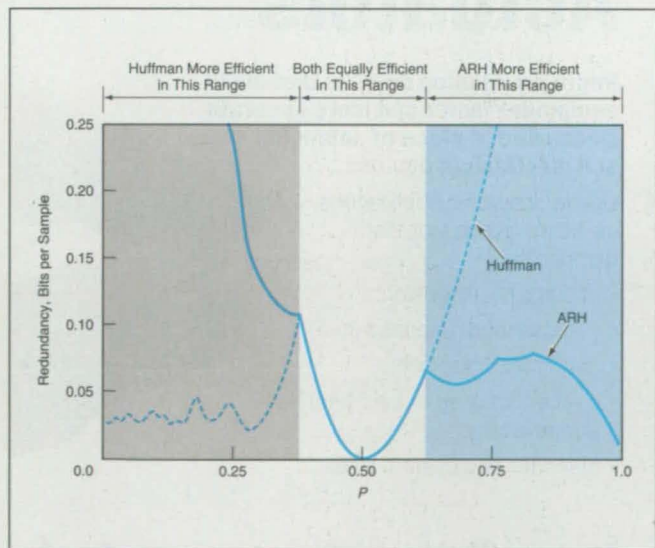

The Redundancies of the Two Codes as functions of the probability ( $P$ ) of occurrence of the most frequent symbol were calculated for a source in which the alphabet of code symbols is the set of non-negative integers and the source statistics are characterized by the distribution probability  $f[j] = P(1 - P)^j$ .



SOLID STATE IS OUR BUSINESS

# NOW!

## COTS Plastic SSR Switches & Protects AC & DC Loads



### OUR RELAYS ARE SOLID IN EVERY WAY

Circuit insurance for critical applications. The SR75's design provides a compact, rugged, solid state relay with short circuit protection. This SR75 plastic 16 pin DIP relay switches high voltage DC loads. It also switches and protects AC loads through a diode bridge. The unit has a short circuit protected 300V power FET switch that is optically isolated. It is rated at 0.75 amp @25°C. The unit is temperature rated at -55°C to +105°C. All units are available with a choice of screening to assure reliable performance. This competitively priced relay is available for delivery now!

**TELEDYNE RELAYS**  
Solid State Products

Innovations In Solid State Switching Technology  
See our products in EEM 1995, Vol. B, Pages B. 1602-1605



12964 Panama Street, Los Angeles, California 90066-6534  
Telephone: 310-577-3825 • FAX 310-574-2015

OVERSEAS: GERMANY +49 (0611) 9276-0; ENGLAND ++ (0) 181-571-9596;  
JAPAN +81 (05) 3+23-1051



# Books & Reports

These reports, studies, and handbooks are available from NASA as Technical Support Packages (TSPs) when a Request Card number is cited; otherwise they are available from the NASA Center for Aerospace Information.



## Machinery/Automation

### Improvements in Ball-Screw Linear Actuators

A report describes modifications of the design of a type of ball-screw linear actuator driven by a dc motor, with linear-displacement feedback via a linear variable-differential transformer (LVDT). The actuators are used to position spacecraft engines to direct thrust. Actuators of the original design were used on the Viking mission to Mars, and the modified design is intended to satisfy the more exacting requirements of the Cassini mission to Saturn. The modifications are directed toward ensuring reliable and predictable operation during a planned 12-year cruise and an interval of hard use at the end of the cruise.

*This work was done by Theodore Iskenderian, Benjamin Joffe, and Robert*

*Summers of Caltech for NASA's Jet Propulsion Laboratory. To obtain a copy of the report, "Ball Screw Linear Actuator," write in 39 on the TSP Request Card. NPO-19685*



## Mechanics

### Space-Suit-Sizing Device

A report that consists of the main text of U.S. Patent 5,409,331 describes a device for adjusting the length of an arm or leg portion of a space suit to fit more than one astronaut. The device includes a stationary ring to which an inner impermeable layer of the suit is sealed, a short tube that is mounted on ball bearings in a circumferential groove on the stationary ring so that it can be turned freely, and an axially translatable (but not rotatable) ring attached to outer layers of the suit.

The outer portion of the translatable ring engages a threadlike groove on the inner surface of the rotatable tube via recirculating balls that travel in the groove, so that turning the tube causes the translatable ring to translate axially to lengthen or shorten the outer layers of the sleeve. As the affected portion of the suit is shortened or lengthened, the impermeable inner layer is simply folded into or withdrawn from the space between the inner surface of the tube and the astronaut's arm or leg.

*This work was done by Hubert C. Vykukal of Ames Research Center. To obtain a copy of the report, "Space Suit Sizing Device," write in 11 on the TSP Request Card.*

*This invention has been patented by NASA (U.S. Patent No. 5,409,331). Inquiries concerning nonexclusive or exclusive license for its commercial development should be addressed to the Patent Counsel, Ames Research Center; (415) 604-5104. Refer to ARC-13377.*

## 12 BIT, 60 MSPS A/D Card For IBM PC

12 Bit, 60 MSPS A/D

8 Bit, 250 MSPS A/D

Up to 16 Cards in one chassis  
Drivers in C, BASIC, DLL,...

Up to 16 Meg Memory  
Low Noise  
FREE Scope Software

World's Fastest  
A/D Cards  
Also Available on  
PCI Bus !!!

Ultra-Fast D/A Cards  
Also Available

CSLITE	ISA Bus 8 bit / 40 MSPS / 16K	\$595
CS250	ISA Bus 8 bit / 100 MSPS / 32K	\$3,500
CS2125	ISA Bus 8 bit / 250 MSPS / 256K	\$4,995
CS1012	ISA Bus 12 bit / 20 MSPS / 512K	\$4,995
CS6012	ISA Bus 12 bit / 60 MSPS / 512K	\$6,995
CS6012/PCI	PCI Bus 12 bit / 60 MSPS / 512K	\$8,995

U.S. Prices listed above. International prices may vary.

# GAGE

## 1-800-567-GAGE

Gage Applied Sciences Inc.

Ask for extension 3405

5610 Bois Franc Street, Montreal, Quebec, Canada H4S 1A9

Tel: (514) 337-6893. Fax: (514) 337-8411, BBS: (514) 337-4317

e-mail: prodinfo@gage-applied.com. ftp site: ftp.gage-applied.com (cd clients/gage-applied/public)

## Multi-layered Piezoelectric Actuators

Micro positioning devices that make equipment faster and more accurate when used in place of solenoids and mechanical devices.

Use in ultrasonic applications, including active vibration dampening.

- microns of expansion
- microsecond response time
- nanometer resolution
- co-fired for greater load bearing and reliability.
- standard and custom sizes

### Morgan Matroc Inc

▲Electro Ceramics Division

232 Forbes Road  
Bedford, Ohio 44146 USA  
(216) 232-8600  
Fax: (216) 232-8731



## New on the Market

Assurance Technologies Inc., Garner, NC, offers the Nano-F/T **force/torque sensor** that provides six axes of force and torque sensing. For use in robotics, medical instrumentation, and articulated fingers, the sensor is available in calibrations to 50 N of force and 0.5 N-m of torque. It comes with an intelligent controller featuring various data output modes.

**For More Information Write In No. 700**



The Daniel Woodhead Co., Northbrook, IL, has introduced the Brad Harrison® **Mini-Change® sensor connection tee** for sensor bus systems. Using flex circuit technology, the tee eliminates unnecessary connection points and minimizes bus line resistance. Its contact design features four female contact beams and a stainless steel sleeve. Pins, sockets, and epoxy-coated coupling nuts are corrosion-resistant.

**For More Information Write In No. 703**

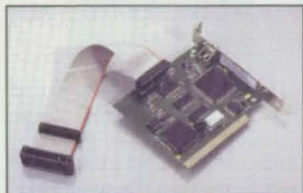

The ME1000 **vidiMate multimedia computer card** from Methode Electronics, dataMate Division, Chicago, IL, displays multimedia presentations on a standard television receiver or records them on a VCR. It converts VGA computer graphics and CAD images into standard NTSC video output. The card can be plugged into any 386/486/Pentium computer using an ISA bus and a graphics card with a feature connector.

**For More Information Write In No. 701**



Wavetek Corp., San Diego, CA, has introduced the Model 296 **50-MHz waveform generator** with up to four independent channels and sequencing that can link up to 4096 waveform segments. Features include a mouse-controlled graphical user interface and waveform editing tools. Waveforms can be downloaded from digital storage oscilloscopes.

**For More Information Write In No. 702**



Omega Engineering, Stamford, CT, offers the OS1553 self-contained **fiber-optic infrared transmitter** with a linear 4 to 20 mA output for monitoring, datalogging, or controlling product temperature via noncontact surface temperature measurements. The device can measure where direct line-of-sight is not possible, and operates from 800° C to 1600° C.

**For More Information Write In No. 707**

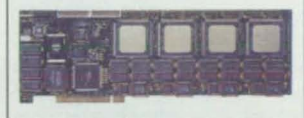

The PCI/C44 **digital signal processing card** from Spectrum Signal Processing Inc., Burnaby, BC, provides a platform for high-speed parallel processing and real-time embedded systems. Larger systems can be constructed by connecting additional boards to the card's communication ports. The card provides an interface to application-specific I/O expansion options.

**For More Information Write In No. 708**



CyberOptics Corp., Minneapolis, MN, has introduced the CyberGage™ **digital laser triangulation sensor**. Producing data in ASCII format for import to a standard PC, it generates up to 2000 readings per second. The device provides noncontact height measurement for custom-designed automated systems, process controls, and quality control equipment. Three interchangeable sensors are available with resolutions from 0.3 to 2.0 microns.

**For More Information Write In No. 711**

Foxboro/I.C.T. Inc., San Jose, CA, has introduced the Model 2600 ISO-Technology® **Dual In-line Pin (DIP) pressure transducer** with a 316L stainless steel diaphragm for process control and medical instrumentation. Measuring 19 mm in diameter, the button transducer is available for gauge pressure ranges of 0-10 to 0-100 psi. The unit is available in compensated or uncompensated versions.

**For More Information Write In No. 706**



Force Imaging Technologies, Chicago, IL, has introduced the UniForce **Experimenter's Kit** for portable force sensing **data acquisition**. Paper-thin sensors are combined with a PC-based data acquisition card and software to form a single-channel force measurement system. The kit includes nine sensors in three force ranges: ISA, PCMCIA, or parallel port I/O expansion cards; a connector cable; and interactive real-time software for displaying calibrated sensor output.

**For More Information Write In No. 704**



The IR Junior **noncontact sensor** from Watlow Electric Manufacturing Co., St. Louis, MO, has a temperature sensing range from 0 to 538° C, and can withstand ambient temperatures from 0 to 80° C. It provides a thermocouple, linear voltage, or current signal output and is available with a right-angle mirror for use in tight spaces.

**For More Information Write In No. 705**

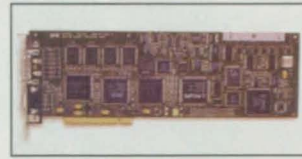

The Pulsar **monochrome PCI frame grabber** from Matrox, Dorval, Quebec, captures from RS-170/CCIR camera and nonstandard video sources. It includes a 16-bit digital data interface and optional input module for 16-bit RS-422 data. The board provides real-time transfer directly to system RAM or on-board display at up to 60 Mb per second.

**For More Information Write In No. 713**



3M Electrical Specialties Division, Austin, TX, has introduced a **heat-shrink tubing kit** for electronics and design engineers to use on small R&D projects or prototype development. The kit contains 133 pieces of 6-inch-long FP-301 polyolefin heat-shrinkable tubing in six diameters and seven colors.

**For More Information Write In No. 709**



Clippard Instrument Laboratory Inc., Cincinnati, OH, offers a **dual flow control valve** with a springless design for low back-flow cracking pressure. Flow controls are contained in the same housing but function independently, allowing separate pressures and/or gasses to be used. Made of anodized aluminum, the valve features 303 stainless steel compound angle needle stems, a nickel-plated valve sleeve, and Buna-N® rubber seals.

**For More Information Write In No. 710**



Edmund Scientific Co., Barrington, NJ, has introduced the K2 and KV **miniaturized long-distance microscopes**. The K2 is used for remote vacuum chamber viewing and on-line process control; the KV is for video-only applications. Featuring a direct C-mount coupling, a manual iris provides illumination and depth-of-field control. Distances from 2" to 60" can be viewed with variable focus.

**For More Information Write In No. 712**

Rustrak Instruments, East Greenwich, RI, has introduced the Rustrak Ranger IV microprocessor-based **data loggers** for monitoring valves, motors, and process variables. Universal input modules allow DC, AC, thermocouple, RH, and RTD measurement. It is available with four, eight, 12, or 16 channels.

**For More Information Write In No. 714**

## New Literature

A specification sheet from Ball Screws & Actuators, San Jose, CA, describes AC- and DC-powered **electro-mechanical actuators** called "Supermovers." They come in six styles with load capacities from 25-1000 lb. and stroke lengths from 2-24 in.

For More Information Write In No. 715



Extech Instruments, Waltham, MA, has released a catalog on **test, measurement, calibration, datalogging, and control products**. Included are multimeters/data acquisition systems, true RMS multimeters, thermocouple and current/voltage calibrators, and pH and conductivity meters.

For More Information Write In No. 716

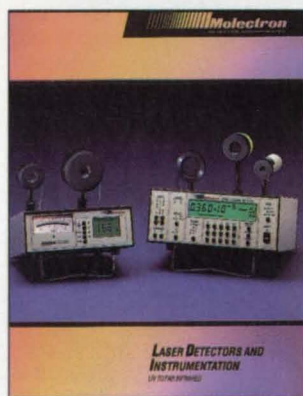

Moletron Detector Inc., Portland, OR, offers a brochure describing **laser detectors and instrumentation** spanning the wavelength range from ultraviolet to far infrared. Described are EnergyMax pulsed laser joulemeter probes and instruments and PowerMax laser power meters, as well as pyroelectric hybrid detectors and thin-film IR polarizers.

For More Information Write In No. 717

An eight-page design guide from Rivnut Engineered Products Inc., Kendallville, IN, provides engineering data and technical specifications on its **internally threaded rivet fastening system**. Also included is information on hand and power installation tools.

For More Information Write In No. 720

The 1995-1996 catalog from OptoSigma Corp., Santa Ana, CA, describes **optics**, including broadband and laser-line mirrors, lenses, beam splitters, polarizers, prisms, microscope objectives, and microlenses. A miniature optical mounting system with stages and component mounts is featured.

For More Information Write In No. 719

Literature from Optrand Inc., Ann Arbor, MI, describes **fiber-optic combustion pressure sensor systems**, including single- and multichannel analog measurement and monitoring devices, a digital sensor interface/data acquisition system for field applications, and ruggedized sensors for differing pressure ranges.

For More Information Write In No. 724



General Extrusions Inc., Youngstown, OH, offers a six-page capabilities brochure describing services in design and production of **extruded aluminum components**. The company offers fabrication, finishing, and assembly capabilities as well.

For More Information Write In No. 721



A 54-page catalog from Wilcoxon Research Inc., Gaithersburg, MD, describes **industrial vibration sensors**. A new product section provides information on sensors and accessories, followed by details and specifications on accelerometers, piezoelectricity transducers, and other products.

For More Information Write In No. 722

The Micro Switch Division of Honeywell, Freeport, IL, has released a revised edition of Catalog 15, "Pressure and Airflow Sensors." Featured are unamplified and amplified pressure **sensors**, temperature sensors, and microbridge airflow sensors, all based on semiconductor technology.

For More Information Write In No. 727



An eight-page booklet from International Electronic Research Corp., Burbank, CA, features schematics, specifications, and information on **heat dissipators and clips** designed for high-speed P6™ microprocessors. The brochure enumerates design features, including IERC's proprietary Super Clip attachment technology.

For More Information Write In No. 729

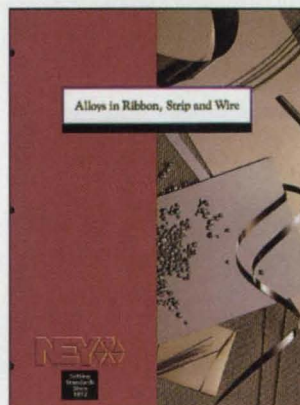

**Alloys in ribbon, strip, and wire form** from J.M. Neyo Co.'s Electronics Division, Bloomfield, CT, are featured in a brochure that provides specifications and application information on Paliney palladium-based and Neyoro gold-based alloys. Each of the six products that comprise these lines is characterized with six key properties.

For More Information Write In No. 718

American Precision Industries, Amherst, NY, offers a catalog of **motion control products**, including step, servo, and brushless DC motors; clutches; gearheads; and operator interfaces.

For More Information Write In No. 730

### Integrated Thermal Spray Systems



Miller Thermal, Inc.

A six-page brochure from Miller Thermal Inc., Appleton, WI, outlines its custom services as a single-source supplier of **thermal spray equipment**. Installation, training, coating development, and metallurgical testing are described.

For More Information Write In No. 723



Wyko Corp., Tucson, AZ, has released a six-page brochure including information about and specifications for its **RST PLUS surface measurement system**. The unit combines phase-measuring interferometry with vertical scanning interference microscopy.

For More Information Write In No. 726

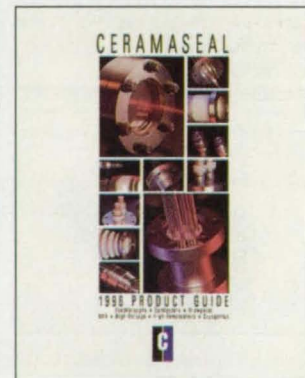

A 1996 catalog from Ceramaseal, New Lebanon, NY, describes **precision-engineered feedthroughs, connectors, viewports, thermocouples**, and other specialty components. A reference section includes information on materials, attachment, technical performance, and installation options.

For More Information Write In No. 728

## New on Disk

### Product of the Month

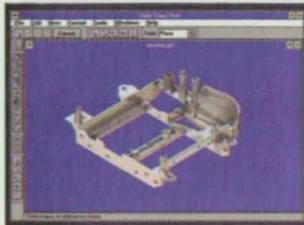

Solid Edge™, new CAD software for mechanical assembly and part modeling from Intergraph Corp., Huntsville, AL, was developed specifically for Windows® 95 and Windows NT™ operating systems. It addresses fundamental mechanical design issues involving parts systems, such as part-to-part interface, interference, and assembly configuration. Solid Edge includes object linking and embedding data server software that enables the user to link, view, and locate models created with other CAD systems. It also incorporates Spatial Technology's ACIS® solid-modelling kernel for advanced 3D mechanical design. It is priced at \$5995.

For More Information Write In No. 737



Ansoft Corp., Pittsburgh, PA, has released Maxwell® Strata, a tool for design and analysis of microwave, millimeter-wave, and radio frequency IC, as well as planar, antennas. Based on the space-domain Method of Moments, Maxwell Strata can solve for the X, Y, and Z parameters and radiation for 2D, 2.5D, and true 3D traces and structures, which can lie either on or within layered dielectric substrates.

For More Information Write In No. 731

Algor Inc., Pittsburgh, PA, has introduced a new version of its mechanical engineering analysis and design optimization software, called the WIN line, that uses the full 32-bit capacity of Windows 95 and runs on Windows NT. Algor offers all of its finite element analysis software in WIN versions; kinematics and rigid-body dynamics will eventually be available in WIN versions too.

For More Information Write In No. 732

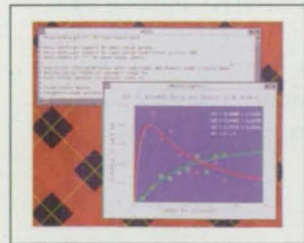

A new version of MLAB mathematical and statistical modeling software from Civilized Software Inc., Bethesda, MD, runs on both Windows 3.1 and Windows 95. Curve-fitting, differential equations, statistics, and graphics are among its capabilities. MLAB for Windows also features the new MLAB Server Program, which will enable program developers to design their own products using MLAB internally. The full MLAB with all extension packages retails for \$1495.

For More Information Write In No. 733

Loral Test & Information Systems, San Diego, CA, says its Visual Telemetry System™ software, the VTS 200, is the first Windows-based telemetry software package to support data acquisition, processing, archiving, display, and distribution in a network-based operating environment. An Ethernet accelerator distributes data for real-time display and processing.

For More Information Write In No. 734

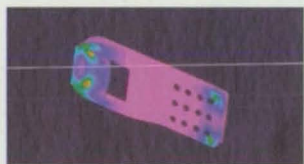

MacNeal-Schwendler Corp., Los Angeles, CA, has announced Version 2 of MSC/NASTRAN for Windows, its integrated finite element analysis and modelling program. The new version includes significant performance improvements in addition to functional enhancements, according to the company. Optional packages for nonlinear analysis and dynamic analysis also are available. A CAD integration option allows ACIS 3D and 2D geometry in SAT files to be imported directly. Version 2 costs \$4995.

For More Information Write In No. 735

Synthesis MKBS, the latest automated drafting and design software from Synthesis Co., Bellingham, WA, is compatible with AutoCAD Releases 12 and 13 for both DOS and Windows. Once a master drawing has been created in AutoCAD and saved in a DXF format, Synthesis' SpecSheet permits the user to create an unlimited number of new drawings within the MKBS program. Price: \$5500.

For More Information Write In No. 736

SPSS Inc., Chicago, IL, is offering Neural Connection™, its new neural network computing product. It is designed for serious analysts involved with prediction, classification, time series analysis, and data segmentation. Suggested retail price is \$995.

For More Information Write In No. 738

# Control

Loss of it can be disastrous. In a high-efficiency, cost-competitive market there's no room for error. CUI Stack's line of optical and magnetic encoders gives you the quality and reliability you need to



MEL Series

maintain your competitive edge. Our innovative development has produced the new MEL series,

an optical encoder with a magnetic drive. No shaft to couple, no alignment concerns, no vibration, no stress on the bearings.



If you need an optical, magnetic, mechanical, shaft, shaftless or contactless encoder, CUI Stack has the value you are looking for in:

## ENCODERS

CUI Stack, Inc.

9640 SW Sunshine Ct.

Beaverton, OR 97005

(503)643-4899 Fax: (503)643-6129

For More Information Write In No. 414

## FREE CATALOG PRECISION OPTICS, LASERS & OPTICAL INSTRUMENTS

Inside you'll find:

- Optical Components
- Test Equipment
- OEM Optics
- Video Systems
- Machine Vision
- Critical Measuring
- Positioning Equipment
- Lasers & Laser Optics
- Magnifiers & Comparators
- Microscopes & Telescopes

OVER 8,000  
OPTICAL  
PRODUCTS



At Edmund Scientific, we specialize in providing technical design and research solutions with our extensive line of precision optics and optical instruments—all of which are in stock and available for immediate delivery. Call today for your FREE 236 page catalog.

**Edmund Scientific Co.**

Dept. 16B1, N954 Edscorp Bldg., Barrington, NJ 08007-1380

Phone: 609-573-6250 Fax: 609-573-6295

CALL FOR YOUR FREE COPY 1-609-573-6250

For More Information Write In No. 415

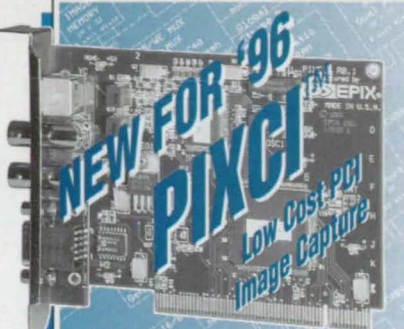

**NEW FOR '96**  
**PIXCI**  
Low Cost PCI Image Capture

- PCI Bus Master
- S-Video, NTSC, PAL, CCIR, RS-170 Inputs
- ± 2 Nanosecond Pixel Jitter
- 8 Strobe/Trigger Signals
- Extensive Processing Software

**EPIX**  
381 Lexington Drive  
Buffalo Grove, IL 60089  
Tel. 708 465 1818  
Fax 708 465 1919  
epix@epixinc.com

© 1996 - EPIX, Inc., USA

For More Information Write In No. 580

## Eliminate Damaging ESD with Staticide®

Staticide is a long-term topical anti-stat that prevents costly damage caused by electrostatic discharge.

- Inexpensive and easy-to-use
- Apply to walls, ceilings, floors, fixtures, work surfaces, equipment & clothing
- Non-flammable, non-toxic and non-staining
- Completely biodegradable
- Available in refillable quart bottle w/trigger spray or gallon bottle
- Meets MIL-B-81705B and NFPA-56A electrostatic decay criteria.



**ACL Staticide**  
Specialists in Static Control  
1960 E. Devon Ave., Elk Grove Village, IL 60007  
**1-800-782-8420**

For More Information Write In No. 581

## DATA ACQUISITION

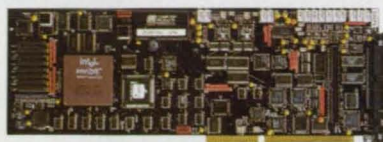

### DAP 3200e™ with onboard 486

- High Speed I/O
- DSP Commands
- Multiboard Systems
- Most PC Software
- Control Loop < 1 ms
- Windows, OS/2 Warp
- External Expansion
- DLL, VBX, Delphi
- DAPtools for HP VEE
- DASYLab, LabVIEW

206-453-2345  
206-453-3199 fax  
info@mstarlabs.com  
www.mstarlabs.com/mstarlabs/

**MICROSTAR LABORATORIES™**  
the onboard intelligence company

For More Information Write In No. 582



**FREE!**  
**130**  
**Page**  
**Catalog**  
-----  
**"Optics**  
**for**  
**Industry"**

Free 130 page product catalog from Rolyon, world's largest supplier of "Off-the-Shelf" optics. 24-hour delivery of simple or compound lenses, filters, prisms, mirrors, beamsplitters, reticles, objectives, eyepieces plus thousands of other stock items. Rolyon also supplies custom products and coatings in prototype or production quantities. **ROLYN OPTICS CO.**, 706 Arrowgrand Circle, Covina, CA 91722-2199, (818)915-5707, FAX (818)915-1379

For More Information Write In No. 583

## 100 MFLOP OEM-DSP \$889 QTY 100

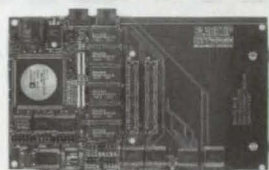

### BLACKTIP

- Analog Devices ADSP-2106x
- SHARC floating-point DSP
- Up to 512K x 48 external SRAM
- Flexible high-speed I/O site
- Two external link ports
- Half-length ISA card
- Free evaluation packages from Hyperception, Ixthos, and Wideband Computers with purchase of development SW

**BITWARE RESEARCH SYSTEMS**  
The SHARC Tamers.  
**800-848-0436**  
33 North Main Street • Concord, NH 03301  
FAX: 603-226-6667 • E-Mail: bitware@bitware.com

For More Information Write In No. 584

## Quit Guessing. Simulate it!

**VisSim™** *New Version 2.0!*

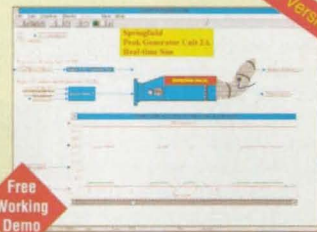

Free Working Demo

VisSim is the ideal environment for nonlinear dynamic simulation, automatic optimization, real-time simulation, and control.

- IIR/FIR Filter Design
  - Fast Real-Time I/O
  - Vector Operations
  - 2000+ real-time I/O points
- VisSim is the best simulation software I've ever used.*  
Robert Josselson, Ph.D.  
Staff Engineer  
Alliant TechSystems

**Visual Solutions INCORPORATED** (508)392-0100  
487 Groton Rd., Westford, MA 01886

For More Information Write In No. 585

# flash memory



Products start at \$79 qty 1

Now get C-programmable miniature controllers with non-volatile "flash" memory. Our **Dynamic C™** development system makes it easy—only \$195. Call our AutoFAX today! Dial 916.753.0618 from your FAX and request catalog #18.

1724 Picasso Ave.  
Davis, CA 95616  
916.757.3737  
916.753.5141 FAX

**ZWORLD ENGINEERING**

For More Information Write In No. 586

## You Can Turn Your PC Into A Waveform Recorder!

Today's most advanced data recording systems are not paper chart recorders. They're paperless, PC-based data acquisition systems from Dataq Instruments. We've replaced traditional instruments in a variety of applications with low-cost and flexible alternatives that save our customers thousands in paper costs alone. Factor in the productivity gains of computer-based analysis, and you have a solution you can't afford to ignore.

- ◆ Battery-powered and desktop solutions
- ◆ Hard copy to any graphics printer
- ◆ Sample rates of 1 to 500,000 Hz
- ◆ Connects from 1 to 240 channels to any PC

**DATAQ INSTRUMENTS, INC.**  
**800-553-9006**

For More Information Write In No. 587

CALL FOR FREE INFORMATION

FULL LINE CATALOG

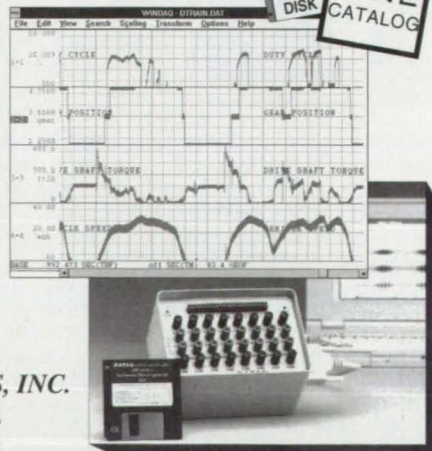



# ADVERTISERS INDEX

## ARE YOU STILL TRYING TO MEASURE VERY THIN GAPS THE HARD WAY?

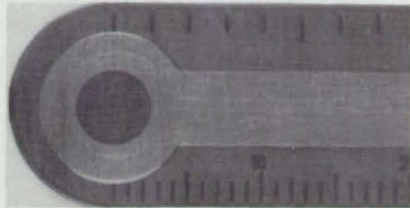

Capacitec HPS Series of thin (back to back) sensors can measure gaps as small as 0.0085" (.22mm) inboard 84" (2133.6mm) with accuracies of 0.0003" (7.6µm), without scratching delicate surfaces.

### Capacitec

P.O. Box 819, 87 Fitchburg Rd., Ayer, MA 01432 U.S.A.  
Tel. (508) 772-6033 • Fax (508) 772-6036

For More Information Write In No. 588

## POSITION ACCURACY to ±0.5 arc second!

Inductosyn® transducers provide absolute or incremental position data to ±0.5 arc second (Rotary) or ±40 microinches (Linear). Resolution to 26 bits.

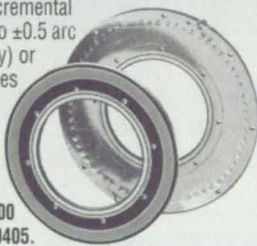

For brochure, call 914/761-2600 or fax 914/761-0405.

**FARRAND CONTROLS**  
DIVISION OF RUHLE COMPANIES, INC.  
99 Wall Street, Valhalla, NY 10595

For More Information Write In No. 589



**Official NASA Tech Briefs Cap**

Sporty poplin cap perfect for golf or any outdoor activity. Red and black NASA Tech Briefs logo on white cap. Size adjustable. \$9.95

Name \_\_\_\_\_  
Address \_\_\_\_\_  
City \_\_\_\_\_  
State \_\_\_\_\_ Zip \_\_\_\_\_

Mail with payment to: Associated Business Publications  
317 Madison Avenue, Ste 921, New York, NY 10017.  
For credit card orders call (212) 490-3999

ACL Staticide.....(RAC 581).....86	Intergraph Corporation (RAC 408,409,411,412).....71,73,75,77
ACR Systems.....(RAC 405).....35	Jandel Scientific Software.....(RAC 625-633).....53
Adaptive Research.....(RAC 524).....59	Lambda Advanced Analog Inc.....(RAC 551).....4
Ad-Vance Magnetics, Inc.....(RAC 460).....2a	MacNeal-Schwendler Corporation.....(RAC 561).....43
Algor, Inc.....(RAC 525).....9	MacSciTech Association.....(RAC 300).....8a
Alligator Technologies.....(RAC 465).....8a	Macsyma Inc.....(RAC 401).....16
American Data Acquisition Corporation (ADAC).....(RAC 403).....29	Master Bond Inc.....(RAC 432).....88
AMP.....(RAC 517).....47	MathWorks, Inc.....(RAC 500).....32a-32b,33
Ansys, Inc.....(RAC 622).....36-37	Microsoft.....(RAC 502).....13
Ansoft.....(RAC 526).....63	Microstar Laboratories.....(RAC 582).....86
Assurance Technologies, Inc.....(RAC 402).....22	Miller Stephenson.....(RAC 406).....45
Astro-Med.....(RAC 609).....31	Minco Products, Inc.....(RAC 420).....78
Belt Technologies.....(RAC 413).....69	Morgan Matroc, Inc.....(RAC 416).....82
Bitware Research Systems.....(RAC 584).....86	NASA Technology CD-ROM.....COV III
Capacitec.....(RAC 588).....87	National Instruments Corporation.....(RAC 503).....COV II
Cole-Parmer Instrument Company.....(RAC 528).....39	National Technology Transfer Center.....(RAC 611).....17
CUI Stack, Inc.....(RAC 414).....85	Optical Society of America.....(RAC 670).....61
Cybernetics.....(RAC 504,603).....7,41	Omega Engineering, Inc.....(RAC 615).....1
Data Translation.....(RAC 530).....15	Paroscientific, Inc.....(RAC 421).....66
Dataq Instruments, Inc.....(RAC 587).....86	Polaroid Corporation.....(RAC 404).....30
Digi-Key Corporation.....(RAC 532).....3	RAG Electronics.....(RAC 508).....5
Digital Equipment Corporation.....18-19	Research Systems.....(RAC 577).....2
Eastman Kodak Company.....(RAC 434).....23	RGB Spectrum.....(RAC 400).....12
Edmund Scientific Co.....(RAC 415).....85	Rolyn Optics Co.....(RAC 583).....86
EDS Unigraphics.....(RAC 451).....5a	Science Accessories.....(RAC 464).....7a
Enterprise Software Products, Inc.....(RAC 462).....6a	Servometer Corporation.....(RAC 424).....70
EPIX, Incorporated.....(RAC 580).....86	Softworld.....(RAC 407).....55
Farrand Controls.....(RAC 589).....87	Sorbothane, Inc.....(RAC 417).....88
Fieldworks Inc.....(RAC 450).....3a	Sun Microsystems Inc.....(RAC 567).....57
Gage Applied Sciences Inc.....(RAC 428).....82	SUNX Sensors.....(RAC 600).....51
Gould Instrument Systems Inc.....(RAC 539).....COV IV	T.A.L. Technologies, Inc.....(RAC 461).....4a
HAL Computer Systems.....(RAC 623).....25	TEC Products and Lab Services.....(RAC 463).....6a
Hewlett-Packard Company.....(RAC 533).....27	Technology Access.....(RAC 418).....72
Hitachi.....(RAC 410).....67	Teledyne Relays.....(RAC 438).....81
illbruck.....(RAC 423).....80	Velmex, Inc.....(RAC 430).....70
Instrumented Sensor Technology.....(RAC 425).....80	Visual Solutions, Inc.....(RAC 585).....86
Intel Corporation.....10-11	Wright Line.....(RAC 429).....67
Intelligent Instrumentations, Inc.....(RAC 419).....78	Xilinx, Inc.....(RAC 683).....48-49
	Z World Engineering.....(RAC 586).....86

\*RAC stands for Reader Action Card. For further information on these advertisers, please write in the RAC number on the Reader Action Card in this issue. This index is compiled as a service to our readers and advertisers. Every precaution is taken to insure its accuracy, but the publisher assumes no liability for errors or omissions.

# Shock & Vibration Damping.

Sorbothane® patented visco-elastic material absorbs and dissipates unwanted energy and outperforms rubber and other materials by providing:

- Impact Absorption  
Vibration Isolation
- Sound Damping
- Excellent Memory
- Quick & Cost-Effective Custom Molding

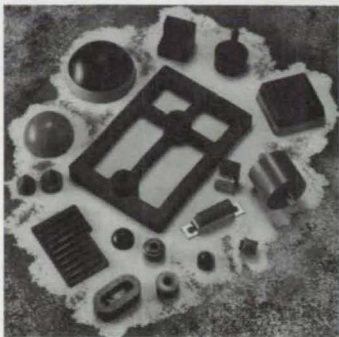

The Solution to all your energy dissipation needs.

For a free brochure and prototype sample.  
**216.678.9444**

**Sorbothane Inc.**

2144 State Route 59, PO Box 178, Kent, Ohio 44240  
216.678.9444 Fax 216.678.1303

For More Information Write In No. 417

# LOW OUTGASSING ADHESIVES

Designed To Your Specifications

## MASTER BOND SUPREME 10HT EPOXY

- One-part system
- Outstanding bond strength
- Fast cures at moderate temperatures
- 400°F thermal stability
- Void free cures
- Long storage stability without refrigeration
- Passes NASA outgassing test

For information, call or write:  
Master Bond Inc.  
154 Hobart Street  
Hackensack, NJ 07601  
201-343-8983

**Master Bond Inc.**  
Adhesives, Sealants & Coatings

For More Information Write In No. 432

## The Technology Connection

To Advertise Call (800) 944-NASA

### Connecting with Consultants

#### East

Robert P. Bell  
Robert Platt Bell, P.C.  
P.O. Box 19668  
Alexandria, VA 22320  
(703) 683-8822

Attorneys specializing in patent application preparation and prosecution, copyright, and trademark matters.

### Engineering Catalog

**80/20 Inc.** FAST  
Manufacturers of The Industrial Erector Set®  
**T-SLOT ALUM. EXTRUSIONS**  
for Machine Frames, Work Stations, Shop Projects, Guarding, Enclosures, Etc.  
Free catalog with over 1400 building components!  
Internet - <http://www.fwi.com/8020>  
**(219) 248-8030 • FAX 248-8029**  
1701 South 400 East • Columbia City, IN 46725

### Partnership Opportunities

**Super-Resolution MM-Wave Imaging, Concealed Weapon Detection, MM/IR Sensor, MM-Wave Multi-Media Communication Module**

Contact Dr. Yu-Wen Chang, Pres.  
Chang Industry, Inc.  
(909) 596-7888 FAX (909) 596-8388

**Carbon-Carbon Heat Sink Components For High Density Electronics Packaging**

Contact: Joseph Garibotti, Pres.  
Applied Material Technologies, Inc.  
(714) 545-8825 FAX (714) 545-2401

**Carbon Composites; Reinforcements; Coatings; Specialty Metal Alloy Powders; Fullerenes; Batteries; Plasma Coated Fibers; Thermal Management**

Contact: Robert Mallia  
Materials & Electrochemical Research  
(520) 574-1980 FAX (520) 574-1983

### 1996 NASA Calendar

Each month features a **full-color photo of the space shuttle in action**. Includes historic launch dates from the 1960s to present. \$10.95 each plus \$5.00 shipping/handling.



Name \_\_\_\_\_  
Company (if applicable) \_\_\_\_\_  
Address \_\_\_\_\_  
City/St/Zip \_\_\_\_\_  
Phone No. \_\_\_\_\_ Fax No. \_\_\_\_\_

**Mail with payment to:** Associated Business Publications,  
317 Madison Avenue, Suite 921, New York, NY 10017.  
Credit card orders call (212) 490-3999.

NASA Tech Briefs, ISSN 0145-319X, USPS 750-070, copyright© 1996 by Associated Business Publications Co., Ltd. Copyright is not claimed for the individual "tech briefs" contained in this publication. The U.S. Government has a paid-up license to exercise all rights under the copyright claimed herein for government purposes. NASA Tech Briefs is published monthly by Associated Business Publications Co., Ltd., 317 Madison Ave., Ste. 921, New York, NY 10017-5391. Editorial, sales, production and circulation offices at 317 Madison Ave., New York, NY 10017-5391. Subscription for non-qualified subscribers in the U.S., Panama Canal Zone, and Puerto Rico, \$75.00 for 1 year \$125.00 for 2 years; \$200.00 for 3 years. Single copies \$10.00. Foreign subscriptions one-year U.S. Funds \$195.00. Remit by check, draft, postal, express orders or VISA, MasterCard, or American Express. Other remittances at sender's risk. Address all communications for subscriptions or circulation to NASA Tech Briefs, 317 Madison Ave., New York, NY 10017-5391. Second Class postage paid at New York, NY and additional mailing offices.

**POSTMASTER: please send changes to NASA Tech Briefs, P. O. Box 10523, Riverton, NJ 08076-0523.**

# THE NASA TECHNOLOGY CD-ROM

## Now Available for the First Time:

The NASA Technology CD-ROM features searchable databases and computer programs representing the best of NASA technology over the last 20 years.

## 800 Previously Unpublished NASA Software Programs

Abstracts to 800+ NASA technical reports with source code listings... reports little known outside of NASA libraries. Million+ lines of FORTRAN, C, Basic, and Pascal code: expert systems, CAD/CAM, aerospace analysis, robotics, materials analysis, and more.

## Abstracts to 90,000+

**NASA Technical Reports** A treasure chest of engineering solutions and new product ideas from the nation's greatest technical minds.

**Front Pages and Claims to 2800+ NASA Patents** Covers patented technologies from the last 20 years.

**Plus These Engineering and Scientific Software Programs Included at No Additional Charge:** **INVICID** flow solver and streamline/pressure graphical display; **CARMS** Markov reliability analysis with spreadsheet/graphical interface; **STARS** for viewing constellations and other objects in the nighttime sky; **TRACK** Earth orbiting satellite tracking display; **QField 2D Finite Element Analysis Program** for heat/stress/electromagnetics; and the **COSMIC Software Catalog**.

**SPECIAL BONUS:** NASA's popular CLIPS expert system with source code and documentation, a \$350 value if purchased separately.

**EXTRA:** The Patent Office is making all US patent abstracts since the mid-1970s available electronically. To help you benefit from this wealth of knowledge, this unique CD-ROM also has: **ManClass** hypertext searchable version of the Patent Office Manual of Classification; **IPNS Archive** — 2 MB of news stories from the Internet Patent News Service; and a hypertext **Manual of Patent Examining Procedure**.

**ALL ON ONE CD-ROM AT THE SPECIAL PREPUBLICATION PRICE OF JUST \$195.00**

**ONLY 1000 WILL BE PRESSED AT THIS SPECIAL PRICE!**

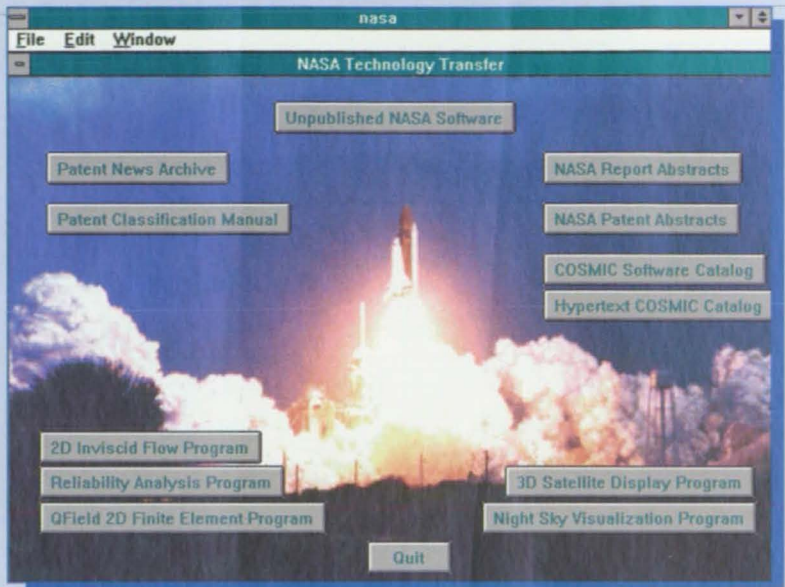

Yes! Send me the NASA TECHNOLOGY CD-ROM at only \$195 (US). (NY residents add sales tax.) CD-ROMS will be shipped January 1996.

Check enclosed (payable to JB Data)

Charge my VISA Card (complete information below and sign)

VISA Card No. \_\_\_\_\_ Exp. date \_\_\_\_\_

Signature \_\_\_\_\_ Date \_\_\_\_\_

Name/Company \_\_\_\_\_

Address \_\_\_\_\_

City/St/Zip \_\_\_\_\_

Phone \_\_\_\_\_

Mail to: JB DATA, 317 Madison Ave., Ste. 921, New York, NY 10017  
Or Fax to: (212) 986-7864/E-mail Order to: pp000531@interramp.com

# Mix multiple instruments into your data acquisition brew and you might conjure up something you wouldn't want to live with!



Used to be, you had to conjure up a variety of test instruments to overcome the inherent limitations of single function products. The result was a monster of different instruments, data formats, cables and user interfaces that increased the headaches, time and cost of design testing.

Now, there's a better way. With the ACQuLab™ Data Acquisition System from Gould Instrument Systems, all critical test functionality is combined in a single system, controlled by a single graphic user interface for enhanced data acquisition, new perspectives and real-time answers to challenging test applications.

Only ACQuLab provides functionality in all five critical areas of data acquisition: input signal conditioning, continuous data acquisition, real-time monitoring, real-time hard copy, and data playback and analysis. With ACQuLab, all



these capabilities are fully integrated and easily transported to remote test locations. And, since ACQuLab converts raw data to useful information at the time and place of acquisition, you make the most effective use of valuable test cell resources.

ACQuLab takes the monster off your bench-top and replaces it with a comprehensive, efficient, real-time data acquisition system.

See how the ACQuLab Data Acquisition System will solve your testing problems. Call (800) 468-5365 today.



**GOULD**  
Instrument Systems

Gould Instrument Systems, Inc.  
8333 Rockside Road  
Valley View, Ohio 44125