

NASA Tech Briefs

National Aeronautics and
Space Administration

March 1987
Volume 11 Number 3



MISSION ACCOMPLISHED:
The America's Cup Comes Home

MAGINATION

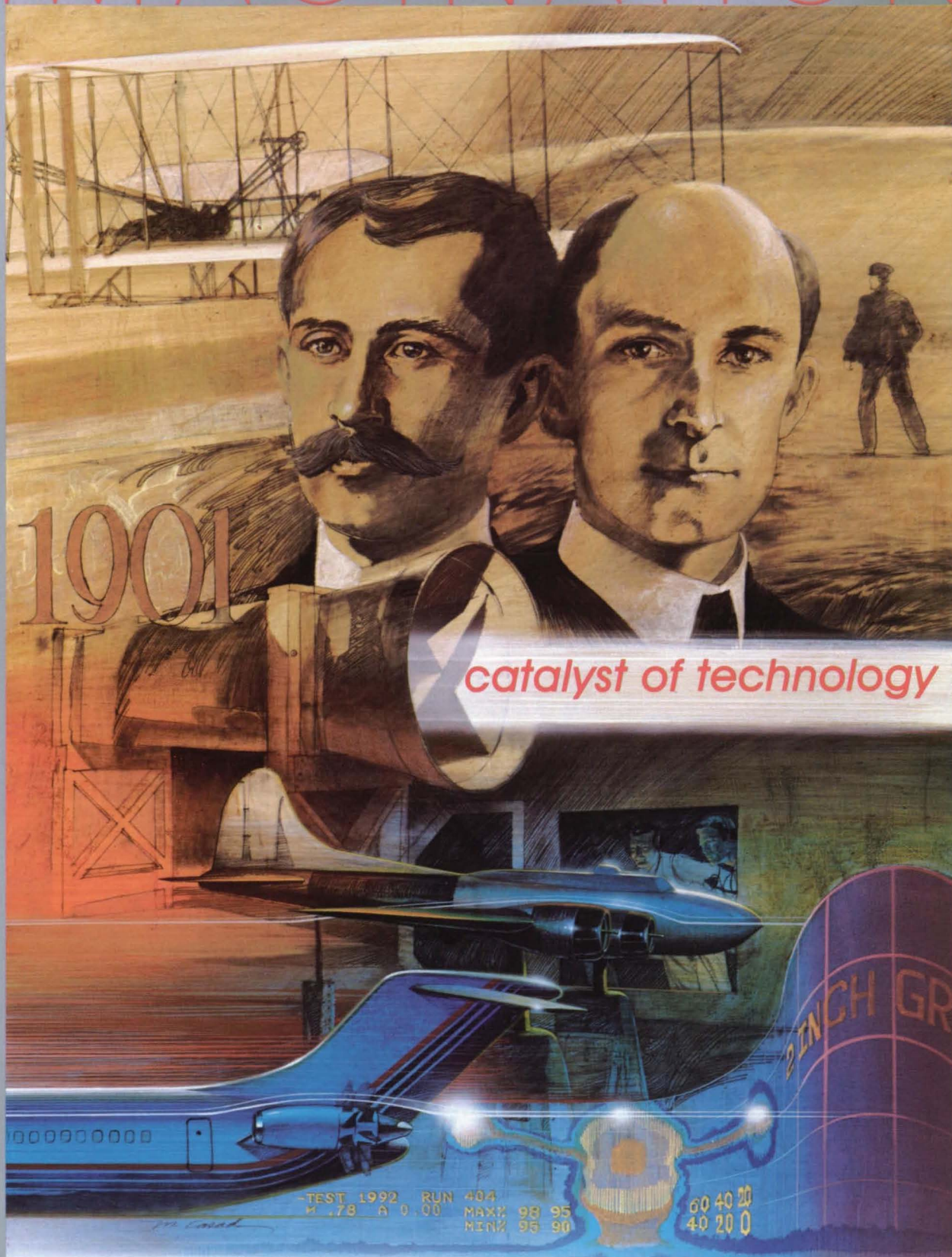

catalyst of technology

The Wright Brothers: Innovators who conquered the wind. In their tradition, Boeing Technology Services offers state-of-the-art wind tunnel testing for your subsonic, transonic, supersonic and hypersonic designs. Wake imaging, model design and fabrication, real-time final data presentation, and more. If you're going higher, farther or faster...call us. We're Boeing Technology Services, The Boeing Company's broker for the technology you need.

**BOEING
TECHNOLOGY
SERVICES**

1-800-237-9555

D. R. Richardson, Marketing Manager; P.O. Box 3707, M/S 9R-28, Seattle, WA 98124; (206) 237-4490

Circle Reader Action No. 367

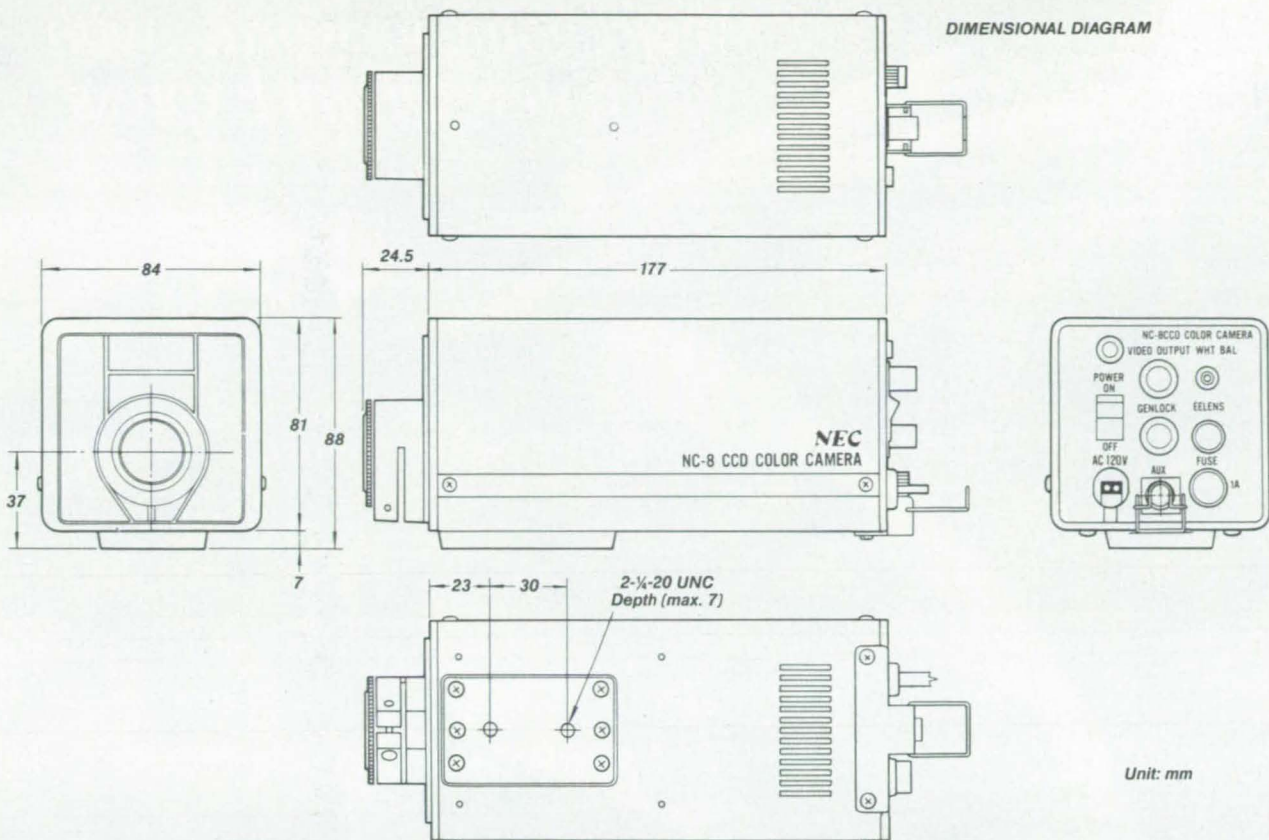

OUR DESIGN FITS YOUR SPECS.

NEC invites you to take a look inside the NC-8 single chip color camera — the camera designed with your specifications in mind. With the lightweight, flexible NC-8, you get high definition and resolution, very low lag and no burn in. It resists shocks, is immune to magnetic distortion, and because its pixels are arranged in a high precision matrix, there is no geometric distortion. It includes Gen Lock as a standard feature. It is equipped for any C-mount lens including auto iris.

This durable little camera is a match for any of your toughest video camera requirements and is easily adaptable to a wide variety of settings.

NEC, the world's largest manufacturer of semiconductors, offers an entire line of solid state industrial cameras—all high quality, hard-working products from a respected source.

NEC

IMAGINE WHAT WE'LL DO FOR YOU



C&C

COMPUTERS AND COMMUNICATIONS

Specifications

Pickup	Interline transfer type CCD x1
Number of picture element	H427xV492
S/N ratio	47dB (illumination channel, standard recording conditions, AGC: off)
Resolution	Horizontal: 280 lines Vertical: 350 lines
Sensitivity	1,600 Lux F4.0
Minimum illumination	10 Lux F1.4 AGC: ON (20% signal output level)
White balance adjustment	Manual/Remote
Lens mount	C-Mount
Power consumption	Approx. 6.5W (less than 9VA)
Weight	Approx. 1.4kg [3.1 lbs] (excluding lens)

For more information about the NC-8, TI-22AII, TI-22PII and TI-26A industrial cameras, contact the Industrial Video Group, Broadcast Equipment Division, NEC America, Inc., 1255 Michael Drive, Wood Dale, IL 60191
Toll free 1-800-323-6656. In Illinois phone 312/860-7600.

Circle Reader Action No. 369

We are going for Mars... with
a new Orient Express™

Ronald Reagan—Feb. 1986
State of the Union Address



Propulsion developers of the future rely on instrumentation from PSI

The success of the Aerospace Plane, *The Orient Express*, depends on the development of the hypersonic scramjet engine.

During the past 8 years at NASA Langley, pressure instrumentation from PSI has played a key role helping engineers evaluate inlet geometry, combustor performance, and nozzle design on prototypes of the hypersonic powerplant.

At Rockwell International, pressure scanning systems from PSI are used to study turbine blade and bearing wear on the shuttle's main engine fuel pumps. *Each 775 lb. turbo-pump develops 77,000 horsepower to deliver over 16,000 gallons of hydrogen per minute to the shuttle's main engine.* Rocketdyne engineers are working to increase the useful life of these incredible performers.

The next generation of propulsion systems must be lighter, faster, and more fuel efficient. This requires a complete understanding of static engine performance and operational transients during throttle excursions. This

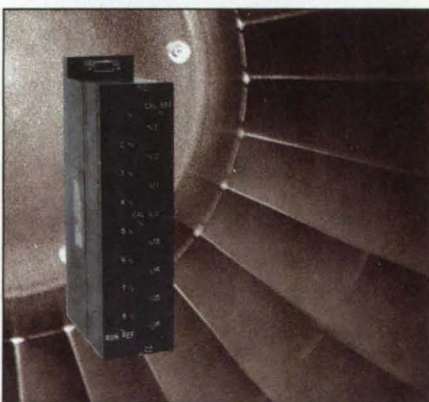

The ESP-16BP pressure scanner has rugged design, transducer compensation, field repairability and it can be mounted on or near an operating engine.

dynamic measurement requires that pressure scanners be located on or near the test engine.

Which is why PSI developed BP (Bullet

Proof) technology. Rugged pressure scanners built to handle the harsh extremes of temperature and vibration *inside* engine test chambers.

As the industry modernizes for the future, PSI's pressure scanning systems have been selected by General Electric, Pratt & Whitney, and Garrett Turbines. In fact, 8 of the 9 major U.S. turbine developers upgrading their test facilities and research labs have chosen PSI.

Moreover, PSI, the developer of electronic pressure scanners for wind tunnels, has installed over 100,000 channels in 10 countries. Our product line has become the standard measurement system for airframe developers, the system of choice for most private and government facilities worldwide.

To find out more, call or write for our free videocassette "Pressure Scanning for Propulsion Developers". Pressure Systems Inc., 34 Research Drive, Hampton, Va. 23666, 804-865-1243 Telex 901-406.



PRESSURE SYSTEMS
Partners in propulsion development

Circle Reader Action No. 378

Special Features and Departments

- 8 Editorial Notebook
- 10 **Back to Basics:**
Materials Research at Lewis
Research Center
- 16 Product Ideas
- 82 Mission Accomplished
- 84 Feedback
- 84 Advertiser's Index
- 86 About This Publication



"Mission Accomplished" describes how NASA-derived technology helped Stars and Stripes recapture the America's Cup. Story by J.T. Pramberger and Robin DuCharme begins on page 82. Cover and additional photos of Stars and Stripes by Tom Martin/Aspen.



During processing, beryllium material is welded into a steel can prior to being rolled into a sheet. Used wherever light and stiff metals are called for, metallic beryllium is produced by Brush Wellman, of Cleveland, OH. (Photo courtesy Brush Wellman).

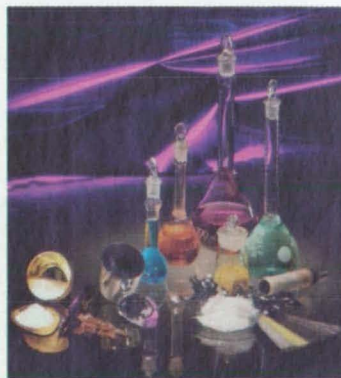













Cooking from scratch, the Lewis Research Center Way. Our story on the Materials Division at Lewis begins on page 10.

This document was prepared under the sponsorship of the National Aeronautics and Space Administration. Neither Associated Business Publications Co., nor anyone acting on behalf of Associated Business Publications Co., nor the United States Government nor any person acting on behalf of the United States Government assumes any liability resulting from the use of the information contained in this document, or warrants that such use will be free from privately owned rights. The U.S. Government does not endorse any commercial product, process, or activity identified in this publication.

NASA Tech Briefs, ISSN 0145-319X, copyright © 1987 in U.S., is published monthly except July/August and November/December (10x per year) by Associated Business Publications Co., 41 E. 42nd St., New York, NY 10017-5391. The copyrighted information does not include the individual Tech Briefs which are supplied by NASA. Editorial, sales, production and circulation offices at 41 E. 42nd Street, New York, NY 10017-5391. Subscriptions for non-qualified subscribers in the U.S., Panama Canal Zone, and Puerto Rico, \$75.00 for 1 year; \$125.00 for 2 years; \$200 for 3 years. Single copies \$15.00. Remit by check, draft, postal or express orders. Other remittances at sender's risk. Address all communications for subscriptions or circulation to NASA Tech Briefs, 41 E. 42nd Street, New York, NY 10017-5391. Application to mail at second-class postage rates is pending at New York, NY 10017 and additional mailing offices.

POSTMASTER: please send address changes to NASA Tech Briefs, 41 E. 42nd Street, Suite 921, New York, NY 10017-5391.

Technical Section Thumb Index

- 18 **NASA TU**
Services 
- 16 **New**
Product
Ideas 
- 20 **Electronic**
Components
and Circuits 
- 26 **Electronic**
Systems 
- 30 **Physical**
Sciences 
- 34 **Materials** 
- 40 **Computer**
Programs 
- 44 **Mechanics** 
- 62 **Machinery** 
- 68 **Fabrication**
Technology 
- 76 **Mathematics and**
Information
Sciences 
- 78 **Life**
Sciences 
- 86 **Subject**
Index 

Thumb Index Technical Section

REMOTE POSITIONING to 0.10 μm ...



With the ORIEL microprocessor based controller for operating up to 3 Encoder Mike DC motor drives.

The controller provides digital position readout to 0.10 microns with resolution of up to 0.02 microns. Full RS232C built in interface allows easy operation with computers such as IBM, Apple, Hewlett Packard, etc. Constant speed scanning is easily accomplished with digital keyboard control of speeds from 0.5 to 200 microns/sec. If you need motorized positioning for alignment, remote control, scanning or point by point positioning, you should know about our 18011 Controller.

See pages 190-191 of Vol. 1, or contact us for information.



Canadian customers call us direct!

ORIEL
CORPORATION

250 LONG BEACH BLVD., P.O. BOX 872, STRATFORD, CT 06497 • (203) 377-8282

FEDERAL REPUBLIC FRANCE UNITED KINGDOM SWITZERLAND OF GERMANY

Circle Reader Action No. 488

NASA Tech Briefs

National Aeronautics and
Space Administration

NASA Tech Briefs:

Published by **Associated Business Publications**
 Editor-in-Chief/Publisher **Bill Schnirring**
 Associate Publisher **Frank Nothaft**
 Managing Editor **R.J. Laer**
 Associate Editor **Leo D. Kluger**
 Technical Advisor **Dr. Robert E. Waterman**
 Art Director **Melanie Gottlieb**
 Associate Art Director **Michelle Schmitz**
 Production Manager **Rita Nothaft**
 Traffic Manager **J.T. Pramberger**
 Circulation Manager **Anita Weissman**
 Controller **Neil B. Rose**

Technical Staff:

Briefs prepared for National Aeronautics and Space Administration by **Logical Technical Services Corp.**, NY, NY
 Technical Editor **Ted Selinsky**
 Art Director **Ernest Gillespie**
 Managing Editor **Theron Cole, Jr.**
 Administrator **Elizabeth Teixeira**
 Chief Copy Editor **Joe Renzler**
 Staff Editors **James Boyd, Larry Grunberger, Jordan Randjelovich, George Watson**
 Graphics **Luis Martinez, Huburn Proffitt**
 Editorial & Production **Lorne Bullen, Bill Little, Frank Ponce, Ivonne Valdes**

NASA:

NASA Tech Briefs are provided by the National Aeronautics and Space Administration, Technology Utilization Division, Washington, DC:
 Administrator **Dr. James C. Fletcher**
 Assistant Administrator for Commercial Programs ... **Isaac T. Gillam IV**
 Director Technology Utilization Division ... **Henry J. Clarks**
 Publications Manager **Leonard A. Ault**

Associated Business Publications

41 East 42nd Street, Suite 921
New York, NY 10017-5391
(212) 490-3999
 President **Bill Schnirring**
 Executive Vice President **Frank Nothaft**
 Vice President **John K. Abely**

Advertising:

New York Office: (212) 490-3999
 Sales Manager **Robin DuCharme**
 Account Executive **Dick Soule**
 Account Executive **Carol-Lynne Cox**
 Advertising Assistant **Erving Dockery, Jr.**

Los Angeles Office: (213) 477-5866

ABP

BPA

THINK SMART.

T**E****K**

Hundreds of leading edge organizations develop practical applications using Tek's Family of AI Workstations. The 4400 Series offers you excellent productivity for rapid prototyping, expert systems building and advanced software development.

This productivity results from Tek's commitment to practical research and development goals. Goals we can help you achieve with tools like Common Lisp and Prolog as well as object-oriented languages like Smalltalk. All optimized to run on Tek's low-cost, high-performance 32-bit workstations.

Add to this the outstanding training and support, and you know why more and more innovative developers are selecting Tek AI systems when they want to think smart.

For more information, circle the reader service card or write to: Tektronix, Inc., AI Marketing, P.O. Box 1000, M.S. 63-635, Wilsonville, OR 97070.

Copyright ©1986, Tektronix, Inc. All rights reserved. VTT-101

Tektronix
COMMITTED TO EXCELLENCE

Circle Reader Action No. 462

200 MB/SEC I/O: APTEC BLOWS AWAY THE SPEED LIMIT

A photograph of a race track at night. The track is illuminated by lights, and there are several cars on the track. In the background, a speed limit sign is visible, showing the number '55'. The sky is dark blue, and there are some lights or sparks in the air.

Introducing Aptec's IOC System 200: blazing fast I/O that blows past the limits of host computer and peripheral throughput.

Until now, 40 MB/sec was the fastest clocking for an I/O bus in real-time environments.

But the IOC-200—Aptec's newest, multi-processor I/O Computer—off-loads I/O from VAX™/VMS™ or other hosts at speeds of up to 200 MB/sec, sweeping away all previous barriers to peak system performance.

Now you can design systems to interact at peak speed with multiple I/O disks. With supercom-

puters. With multiple A/D converters, array processors, custom devices, and more. All performing concurrently at maximum transfer rates.

There's virtually no I/O slow-down. Not even for the most strenuous real-time applications in data acquisition. Simulation. Signal or image processing.

VAX and VMS are trademarks of Digital Equipment Corporation. Aptec participates in Digital Equipment Corporation's Cooperative Marketing Program. Specifications subject to change without notice. OEM arrangement available.

Copyright © 1987 Aptec Computer Systems, Inc.

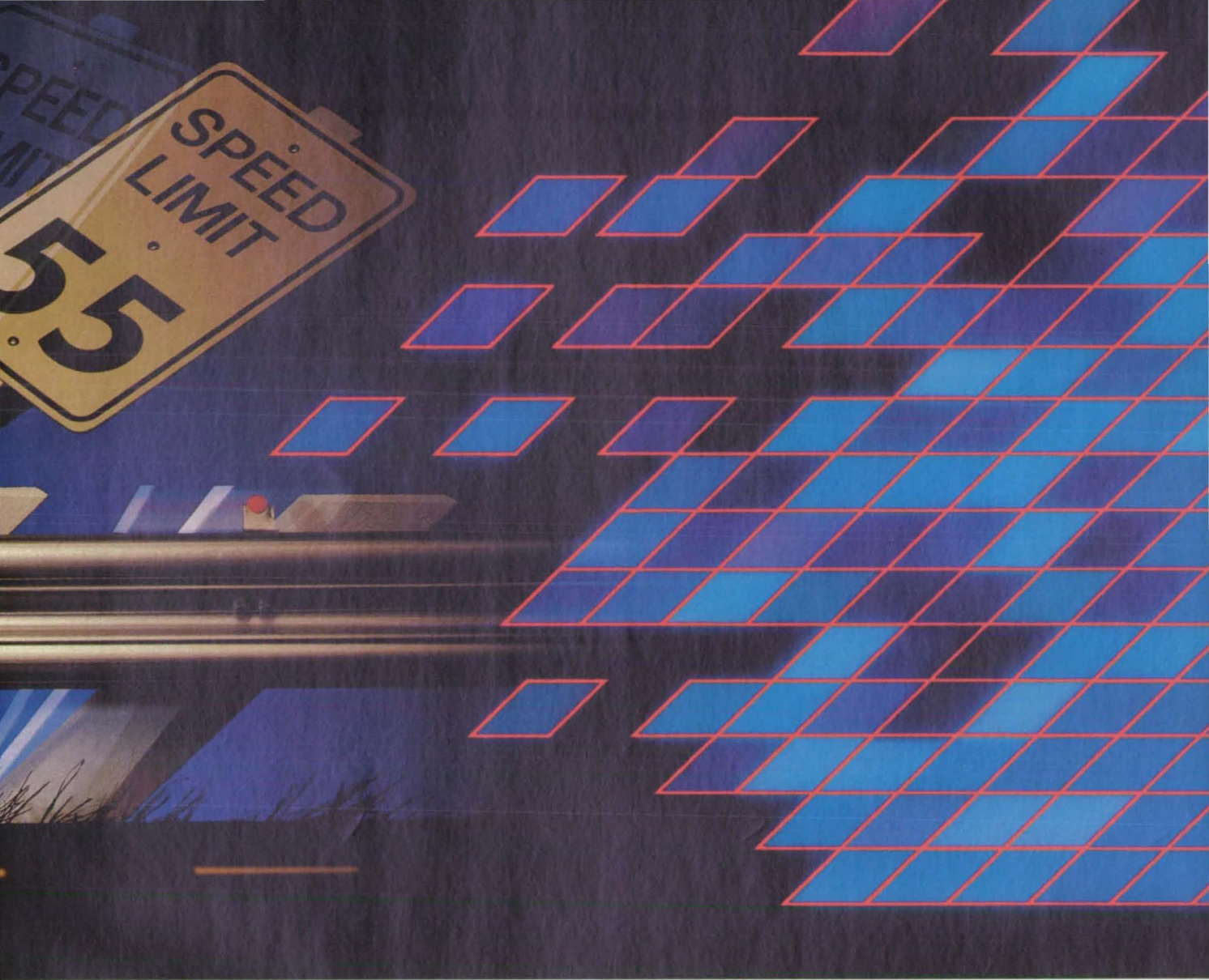

Measure Aptec performance by the company we keep. Boeing, General Electric, Honeywell, Hughes Aircraft, JPL, Lockheed, Naval

Research Laboratories—these are just a few of our *repeat* customers: proof of our product reliability and system support.

Learn how you can push your system to unprecedented limits. Call Aptec today: 1-800-552-7832.

A QUANTUM LEAP FROM THE I/O COMPUTER LEADER

P.O. Box 6750
Portland, Oregon
97228-6750
(503) 626-9000
Telex: 467167



The Mission Accomplished story in *NASA Tech Briefs* has particular relevance this month. Dennis Conner, the skipper of *Stars & Stripes*, the successful challenger for the America's Cup this year, was truly a man on a mission. Ever since he became the first man to lose the Cup, to the Australians in 1983, his mission has been to win it back. This year he did just that.

The mission was accomplished with help from the successful transfer of

NASA-derived technology. It gave all of us at *NASA Tech Briefs* and those associated with technology transfer a boost to know that the technology used by *Stars & Stripes* was first published in the pages of *NASA Tech Briefs*, and then featured in Spinoffs. Riblet film, the technology to which I'm referring, was said to have added as much as 1/2 knot to the speed of *Stars & Stripes*. That's like having a supercharger over the course of a 24 mile sailboat race.



The success of *Stars & Stripes* points out once again that it's the little things that make the difference. When I picked up a piece of the riblet film that was applied to the hull of the yacht, I wasn't able to discern by touch any riblet or anything. It felt as smooth as a regular piece of tape.

Many readers have written to tell us that the general public ought to know more about the benefits we have all derived from the technology developed through NASA's efforts. We live in a society that places great emphasis on sports and nationalism, and when the two combine as they have in this instance, it makes excellent newspaper, magazine and television copy. Personally I'm looking forward to the day when the invention of a rechargeable pace maker or a programmable, implantable medication system will make equivalent headlines in the consumer media. I am told I may be looking forward for quite some time... but that's the subject for another editorial.

A Few Housekeeping Announcements

Those of you who have written in to ask how you can tell when your subscription expires will be happy to know that plans are afoot to make the top set of numbers on your address label comprehensible to anyone with a reading knowledge of Arabic. Numbers that is. We have received a tentative blessing from the Post Office to change the labels so that you'll be able to know easily when you need to fill in the re-qualification form. Stay tuned, it's coming. As are real peel-off labels and cards that don't require herculean strength to remove from the magazine. We hear you, and we're working on making the magazine better. □

Brie Scheraga
NASA Tech Briefs, March 1987

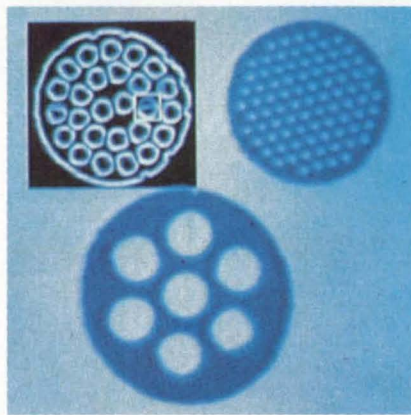

Industrial image processing: detection of fault in electrical connector

Vista-IPS

IMAGE PROCESSING DEVELOPMENT SOFTWARE

If you are developing image processing techniques, then you should know about Vista-IPS™ for:

- remote sensing
 - industrial inspection
 - infra red
 - sonar
 - data compression
 - X-ray
- and many other applications.

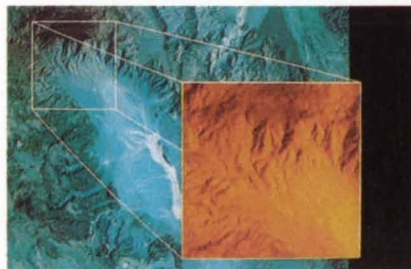

Information extraction from Landsat satellite images: Death Valley, California

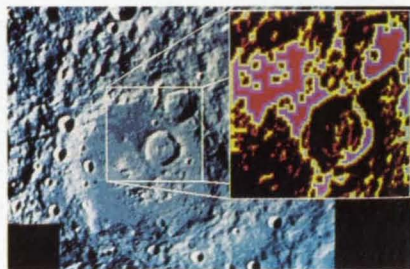

Features extracted from a moon image

For more information contact-

LOGICA INC
372 Washington St.
Wellesley Hills MA 02181
tel (617) 235-2424

Outside USA, Vista-IPS is sold under the name LUCID. Call Logica UK at +44 1 637 9111 or your local Logica office.

logica

THE KLINGER ARGUMENT AGAINST COMPROMISE:

**ONLY WE LET YOU SELECT FROM OVER
200 DIFFERENT STAINLESS STEEL LINEAR STAGES THAT
GUARANTEE POSITIONING TO 1 MICRON OR BETTER.**



Whether your work involves laser machining, semiconductor probing, inspection, optical systems, or any other positioning application, Klinger's high accuracy MR/MRT stages provide cost-effective solutions to the most demanding design problems.

From the smallest manually operated stage made to one capable of carrying 150 pounds, these linear positioners offer a choice of drive methods which include precision micrometers, fine pitch screws, or digital micrometers.

Our MRS linear stages are provided without any drive mechanism allowing you to devise your own method of actuation.

All of our linear stages use a precision-ground bear-

ing system that guarantees their trajectory accuracy, and they can be assembled for XY or XYZ applications. Options include preparation for vacuum and clean room environments.

Don't compromise. The best is always a bargain. Klinger standards of engineering and manufacturing, as exemplified by our manually operated linear stages, have made us the world leader in micropositioning systems. Get our free 212-page micropositioning handbook for complete specifications on these and thousands of other components.

Write or call Klinger Scientific Corporation, 110-20 Jamaica Avenue, Richmond Hill, NY 11418 (718) 846-3700.

KLINGER SCIENTIFIC



Worldwide Network to Meet Your Needs • France: Micro Controle, Evry, (tel.) 6-077-82-83 • West Germany: Spindler & Hoyer, Gottingen, (tel.) 49/551/620/16
Canada: Optikon Corp. Ltd., Waterloo, Ontario, (tel.) 519/885/2551 • England: Unimatic Engineers Ltd., London, (tel.) 44/1/455.00.12
Netherlands: Elmekanic N.V., Hilversum, (tel.) 31/35/43.070 • Sweden: Martinsson & Co. Hagersten, (tel.) 08/744/03/00
Switzerland: G.M.P.S.A., Lausanne, (tel.) 41/21/33/33/28 • Italy: Leitz Italiana, Milano, (tel.) 39/2/27/55/46 • Japan: Hakuto Co. Ltd., Tokyo, (tel.) 03/341/2611.

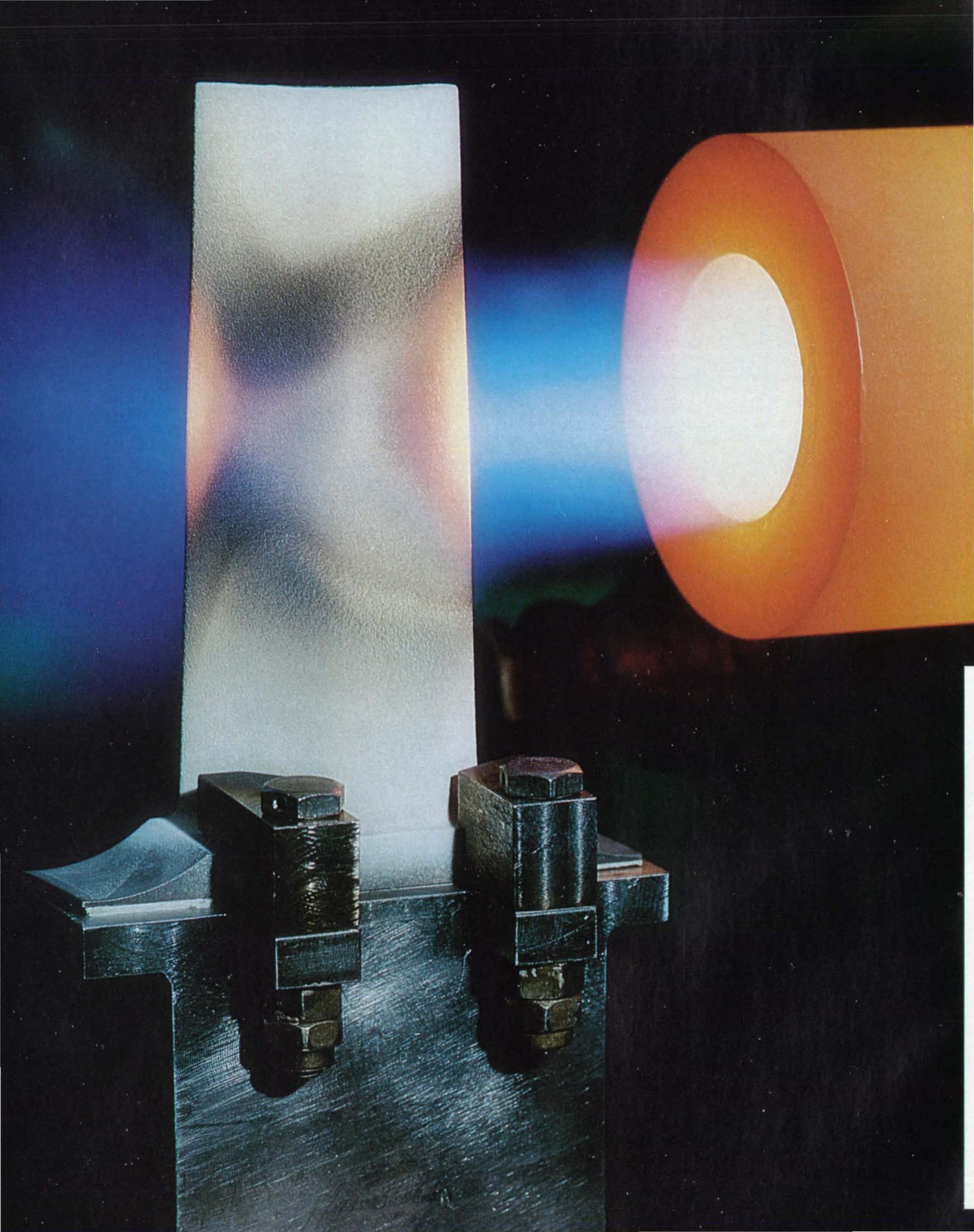

Back to Basics

Materials Research at NASA's Lewis Research Center

In the never-ending push for higher performance and improved efficiency, NASA continues to create lighter, more durable and reliable materials that can withstand higher temperatures and greater stress. Current Agency-wide research in support of these goals has focused on improved monolithic materials and metal and ceramic matrix composites, the synergistic ideal.

At Lewis Research Center, in Cleveland, Ohio, developing high performance aerospace propulsion and power systems calls for state-of-the-art materials research. With world-class facilities, the Materials Division at Lewis develops and tests the best in materials, concepts and processes. "We're pushing the very edges of where materials can be applied," says J. Stuart Fordyce, Director of Aerospace Technology at Lewis.

The Metals Science Branch

A tough metal is hard to find. Rather than settling with known metals for new and demanding applications, or trying through trial and error to come up with the right composition, Lewis metallurgists design for the application, predicting the correct combination of raw materials that will give the desired final product. This efficient alchemy requires a complete understanding of how a metal's microstructure determines its mechanical properties.

Comprehension is key at Lewis' Metals Science Branch.

According to Hugh Gray, Branch Chief, "we seek a basic understanding of advanced materials and processes, from rapid solidification of metallic materials to fatigue testing of metallic composites."

The Metals Science Branch also investigates single crystal composite materials, seeking to understand their microstructure. In the microgravity science area, Lewis metal researchers explore convection in melted metals. Applying that information to normal gravity situations will improve earth-based materials and processes.

Advanced Metallics Branch

Just as steel bands improve the durability and utility of rubber tires, metals benefit from reinforcing fibers. The Advanced Metallics Branch, head- ▶

Testing Ceramic coatings at 1400° F at Lewis Research Center. The inset shows the Material Division's arc-spray monotape fabrication technique, which garnered them an IR-100 award in 1986.

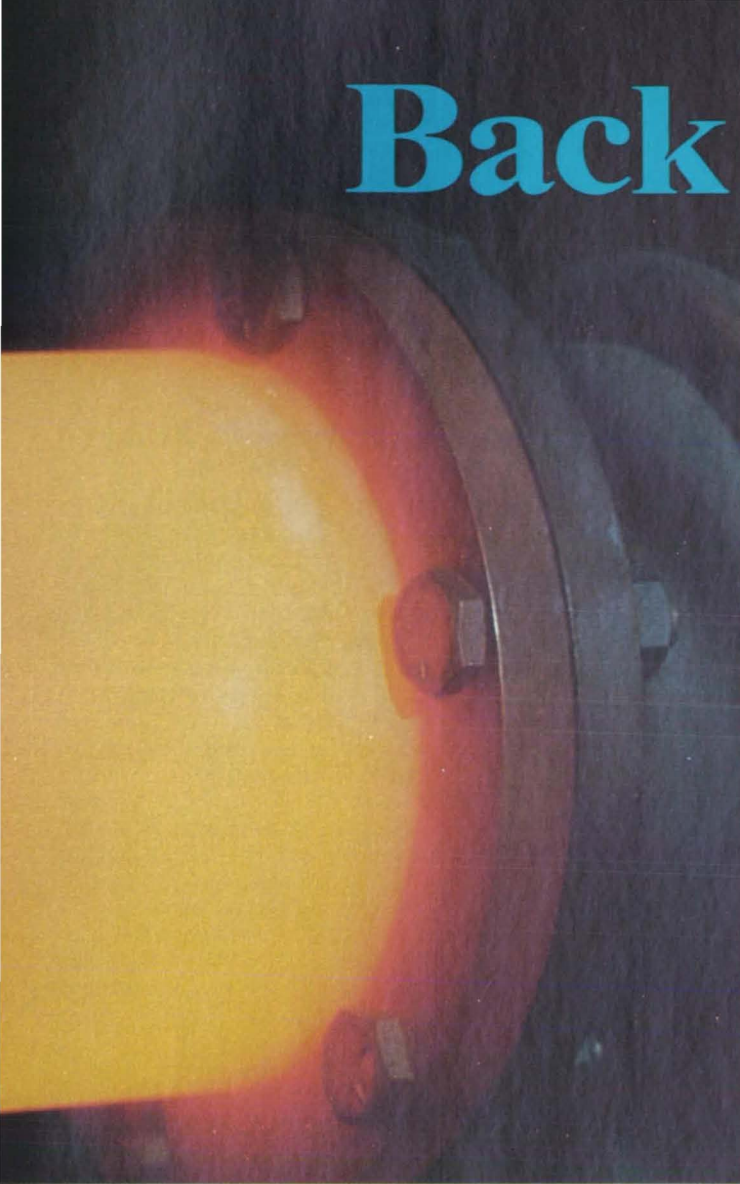

ed by Joe Stephens, researches metal matrix composites using conventional alloys such as copper and fibers of metal, graphite or silicon carbide.

Lewis intermetallic research brought them one of their three IR-100 awards in 1986, the arc spray monotape fabrication technique. In this process, liquid metal sprays onto an array of fibers, producing a thin composite monotape.

Polymer Branch

In the realm of polymer matrix composites, Lewis Materials Division researchers in the Polymer Branch produce advanced composites, whose quality of stiffness is measured in modulus. Polymer resins make up the matrix, with the fibers composed of carbon, glass, boron or aramid. After the fibers are impregnated with resin, the composite hardens, ready for assembly into prepreg panels.

Additional polymer research examines intercalation, the insertion of guest atoms between the graphite planes of a graphite fiber-epoxy composite to change the properties of the end material. Bruce Banks, a Lewis Researcher, intercalates bromine atoms to make the fiber-epoxy composite electrically conductive. Because the bromine doesn't compromise the composite's mechanical

properties, it can serve several functions, filling structural, thermal and electrical requirements.

The Ceramics Branch

Less reactive to the environment than metals, monolithic ceramics are commonly used as thermal barrier coatings, extending the life of turbine blades. Different thermal coatings are easily tested, only minimally influencing other turbine design considerations. "A thermal barrier coating can be added on pretty much after the fact," says Carl Lowell, Deputy Chief of the Materials Division. Current Lewis research in this area concentrates on improving the durability of the bond between the coating and the metal's surface.

Monolithic ceramics are often made from zirconium oxide, which changes volume as it heats and cools. These changes are minimized through the addition of yttrium oxide. By using *ytterbium* oxide, Lewis ceramicists have improved stability, an innovation that led to another of their 1986 IR-100 awards.

Though monolithic ceramics are the best material for a number of structural applications, processing-induced flaws can limit their utility. Placing fibers in the ceramic matrix reduces this problem.

Lewis researchers in the Ceramics Branch are currently improving the silicon carbide fibers used in silicon-nitride matrix composites. "We think that our ceramic composite has the best properties of anything in the world that we know of; it has potential for use up to 2500 degrees Fahrenheit and has better high temperature strength retention than any of the commercially available composites," says Lowell.

Environmental Durability Branch

In a jet engine, temperatures often reach 2000 degrees Fahrenheit or greater. Materials engineers must create materials that can stand these extreme environments, while keeping them as light as possible.

The task requires a complete understanding of the high temperature environment and the forces at play. The Environmental Durability Branch reduces these variables to quantifiable equations. The durability of various materials are also evaluated, as are the suitability of coatings that extend the life of suitable materials. According to Branch Deputy Chief Leslie Greenbauer-Seng, "We have a continuing effort on thermal barrier coatings (TBCs). We have pretty good temperature



ELECTROMAGNETIC INTERFERENCE
ELECTRONIC CORES



carbonyl iron powders

"The Right Stuff"

POWDER METALLURGY
INJECTION MOLDING

GAF is the sole domestic manufacturer of Carbonyl Iron Powders. For more detailed information, contact GAF Corporation, Chemical Division, 1361 Alps Road, Wayne, NJ 07470, (201) 628-3000.

INVEST IN ONE OF OUR NEW FT-IR SPECTROMETERS.

IT'LL GROW ON YOU.

When you invest in a Digilab FT-IR spectrometer you're getting an instrument that's expandable with accessories and software to meet virtually any application you'll ever encounter.

For example, should you ever need expanded IR range, we have additional optical benches (and kits): one for near-IR, another for far-IR, and a vacuum bench for the most demanding far-IR work.

We cover the whole scope of applications by offering the largest range of accessories. These include photoacoustic, diffuse reflectance, three high performance FT-IR microscopes, and ATR for liquids and solids. Our high sensitivity GC/IR system, with full spectrum library search, characterizes complex mixtures rapidly and routinely.

Additional software packages apply four advanced quantitative algorithms to perform accurate multicomponent analyses.

As your laboratory's work load increases, we offer external sample compartments where additional accessories and experiments may be permanently set up. And with desktop Spectroscopic Productivity Centers, you can store and examine spectra with full software power without tying up the spectrometer.

So, when we say "it'll grow on you," we speak not just of your affection for your new FTS spectrometer. We refer as well to its seemingly endless capacity to meet your applications needs and solve your analytical problems.

Call (800) 225 1248 ext. 150 today (in Massachusetts call (617) 868 4330) for more information. Or write Bio-Rad, Digilab Division, 237 Putnam Avenue, Cambridge, MA 02139.

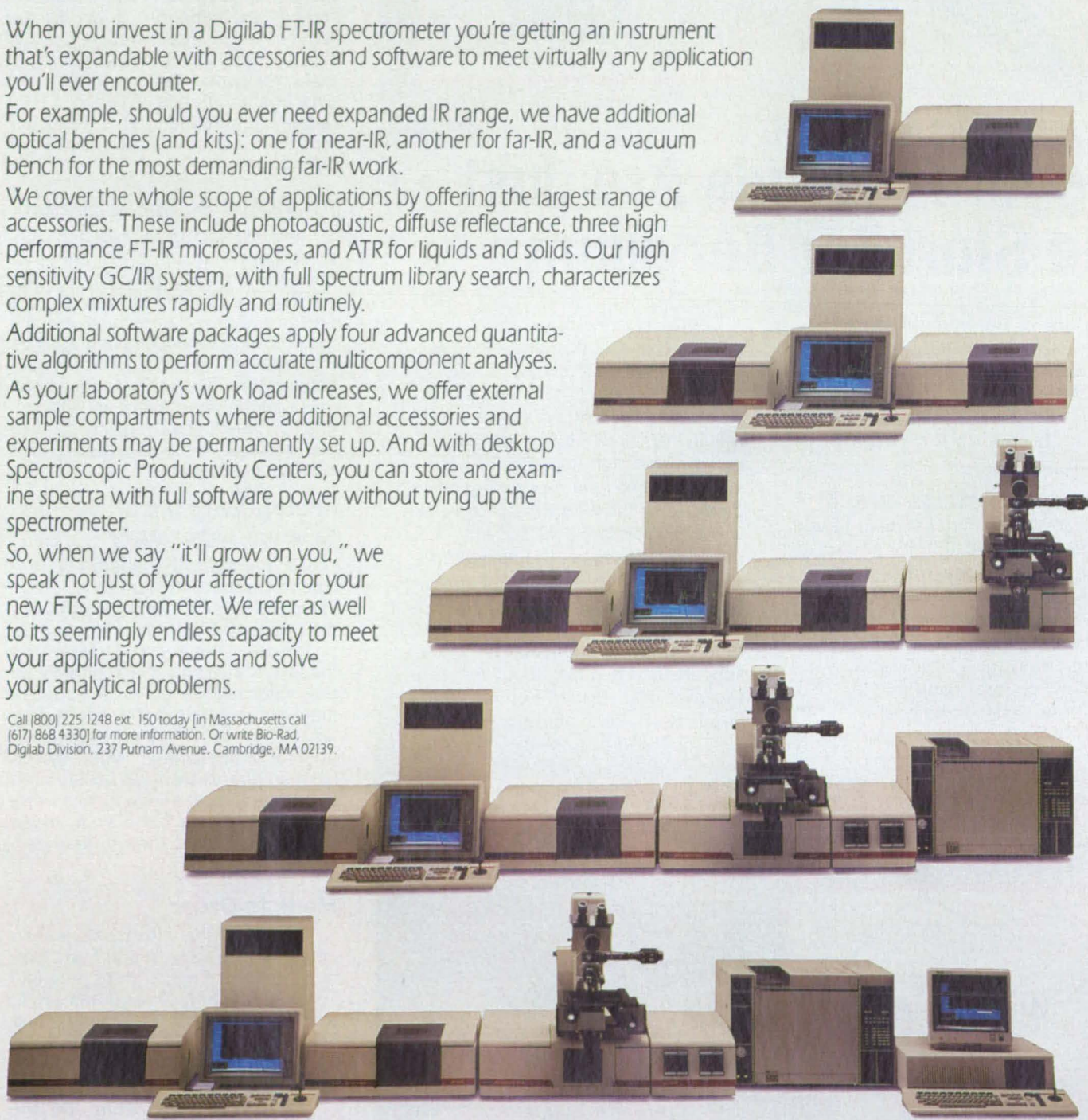

Another optical bench for near or far-IR.

The FTS 60 FT-IR Spectrometer, including research-grade optical bench and expandable data system.

External sample compartment and UMA 300 microscope.

High sensitivity GC/IR accessory (shown with Hewlett-Packard GC).

Spectroscopic Productivity Center for data storage and analysis.

BIO-RAD

**Digilab
Division**

Circle Reader Action No. 485

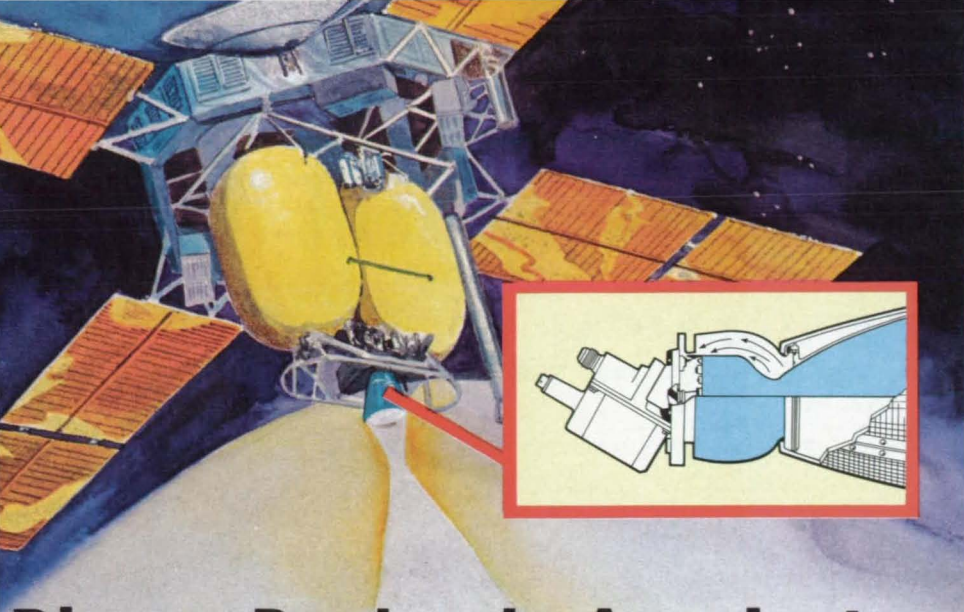

Bigger Payloads Are Just The Start For Beryllium

As one of the lightest structural metals known, beryllium is a logical choice for many payload-sensitive parts. But just as important is the excellent performance of this material once it's off the launch pad.

Beryllium engines for directional thrusters, for instance, have proven highly reliable for station keeping and maneuvering in space. The five year odyssey of the Viking Mars probe is just one outstanding example. With a melting point of 2345°F and excellent thermal conductivity, beryllium easily handles the 450°F hot core in these engines.

On the space shuttle, the navigation base and the two adapter plates for the star tracker boom must be extremely stiff and stable to provide the critical alignments needed for accurate space navigation. The high specific stiffness and excellent heat dissipating qualities of beryllium help combat the inertial, vibro-acoustic and thermal stresses on the beryllium window frames, brakes and umbilical door components.

Beryllium is even more versatile than these two applications suggest. Learn more about the material from Brush Wellman Inc. South River Road, Elmore, Ohio, 43416, (419) 862-2745.

BRUSHWELLMAN
ENGINEERED MATERIALS

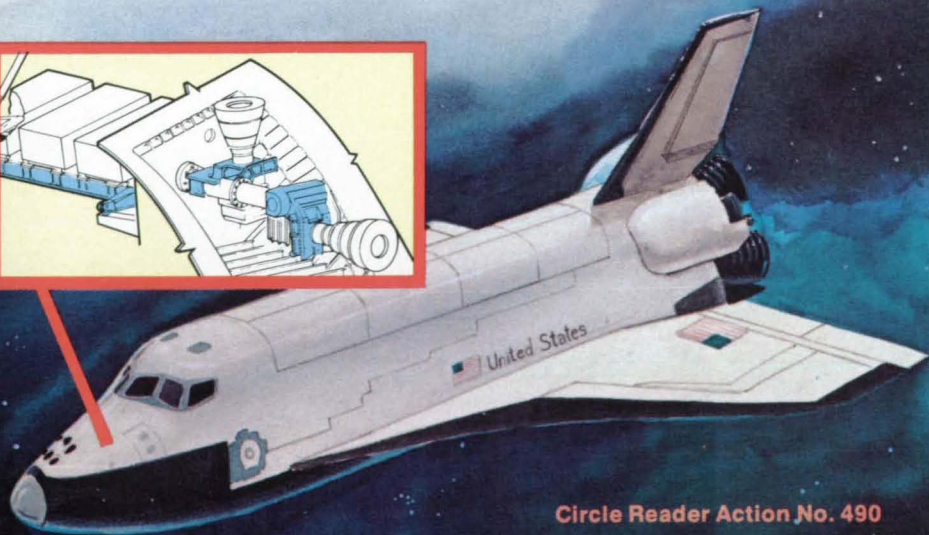
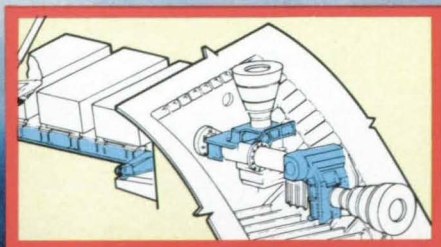

Circle Reader Action No. 490

capability up to about 2100 degrees Fahrenheit, but we'd like to push it above 2200 degrees."

Surface Sciences Branch

Studying the interactions of solid surfaces to each other and to the environment enables Lewis researchers in the Surface Science Branch to accurately predict how a material will degrade under different conditions. "We have a strong expertise in looking at the fundamentals of surface and interface phenomenon, down to the atomic level," says Lowell. A result of this expertise is a plasma-sprayed solid lubricant with good friction and wear characteristics up to about 1700 degrees Fahrenheit. This lubricant won them a third of their three IR-100 1986 awards.

Analytical Sciences Branch

The Analytical Sciences Branch provides analytical support to the other branches of the Materials Division. According to Robert Davies, Branch Chief, "We provide chemical and microstructural services to characterize the materials produced and investigated by the research branches here, using techniques such as spectrography, metallography, gas and chemical analysis, x-ray diffraction, and electron microscopy."

Microgravity Materials Science Laboratory

The microgravity laboratory provides an opportunity for Lewis researchers and outside investigators to test their ideas that might lead to space experiments. "We try to sharpen the focus of a microgravity experiment so that when we do go to orbit, we're more certain of getting the information we want," says Thomas K. Glasgow, director of the facility. "Our research lab is unique in that it was constructed to provide a service not only to government researchers but also to those from industry and the universities," he adds.

Made to Order

The exactitude with which researchers at Lewis can predict and produce materials holds great promise. Turning handfuls of sand and metal ore into the stuff of industry and aerospace stands as a far cry from the first man-made composites of straw-reinforced bricks. □

For further information on the Microgravity Materials Science Laboratory, and to obtain an application for use of its facilities, contact Thomas K. Glasgow, NASA Lewis Research Center, Mail Stop 105-1, 21000 Brookpark Road, Cleveland, OH 44135, (216) 433-5013.

Gould's new thermal array technology expands your recording limits.

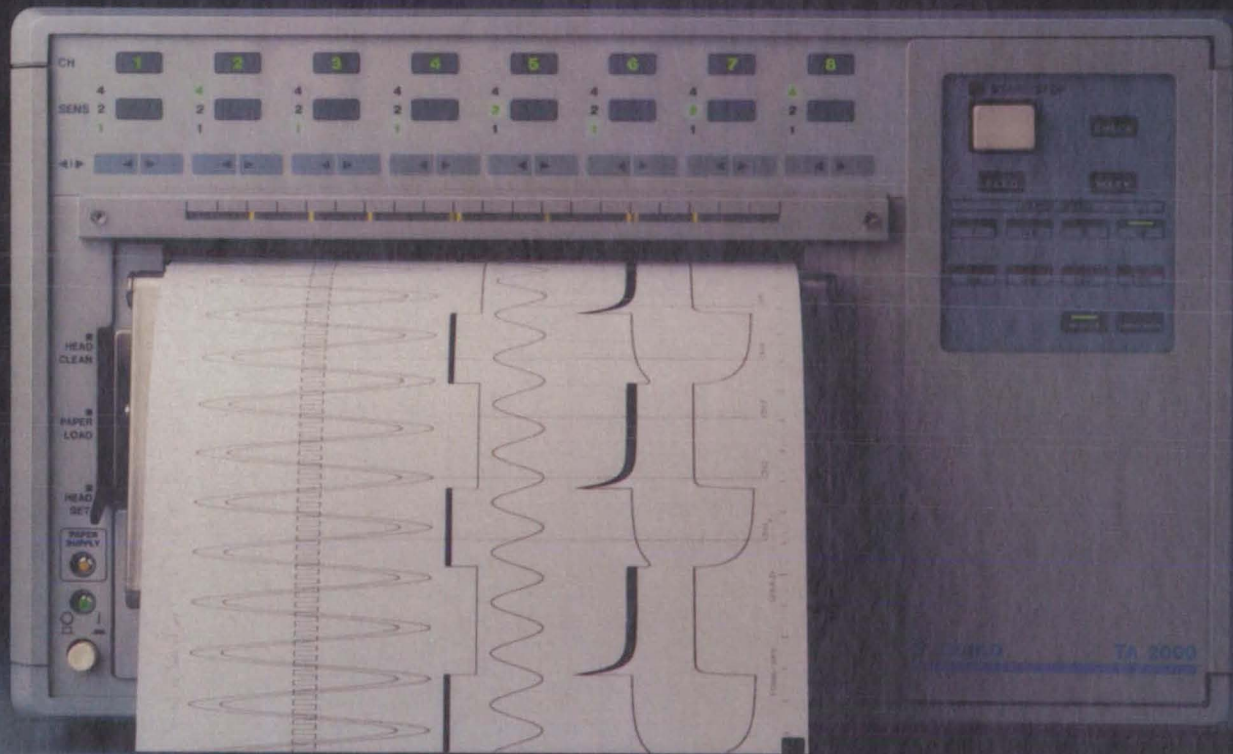

With Gould's new eight-channel TA 2000 Thermal Array Oscilloscope, you'll get high recording performance and increased flexibility with less effort.

Unpack your TA 2000 and use it immediately. You'll find a front panel with instantly recognizable keys, organized in a familiar, traditional design.

Its penless digital writing system provides increased flexibility in chart formatting. Use front-panel controls to overlap traces and to expand them over the full 200-mm

chart width. And, to position individual channels in exact 1-cm increments. An LED array follows trace position and verifies signal amplitude in real-time, eliminating the need to run the chart drive during setup.

The 200-dots/mm resolution makes even complex traces easy to read, and the 200-mm/s maximum chart speed expands signals for accurate analysis. Further, frequency response up to 2.5 kHz and peak capture of events 150 μ s or longer expand

the range of applications you can address.

The TA 2000 offers comprehensive annotation and it's compatible with Gould's more than 40 general- and special-purpose signal conditioners.

To schedule your in-person demonstration of the benefits of Gould's new TA 2000, call **1-800-GOULD-10**, or write Gould Inc., Recording Systems Division, 3631 Perkins Avenue, Cleveland, OH 44114.

 **GOULD**
Electronics

New Product Ideas



New Product Ideas are just a few of the many innovations described in this issue of *NASA Tech Briefs* and having promising commercial applications. Each is discussed further on the referenced page in the appropriate section in this issue. If you are interested in developing a product from these or other NASA innovations, you can receive further technical information by requesting the TSP referenced at the end of the full-length article or by writing the Technology Utilization Office of the sponsoring NASA center (see page 19). NASA's patent-licensing program to encourage commercial development is described on page 19.

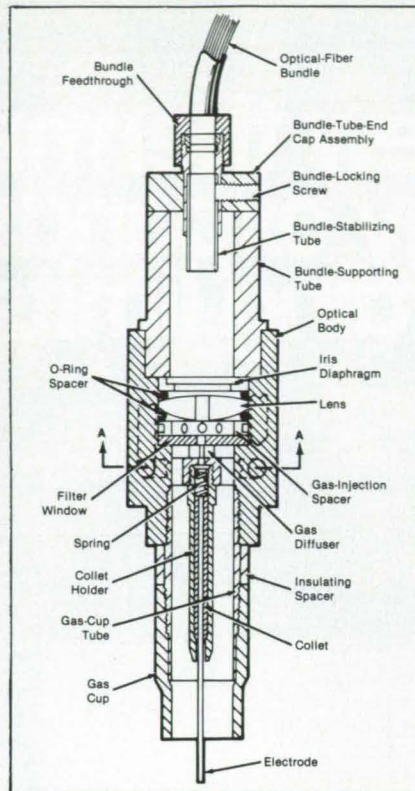

Optical Welding Torch

A gas/tungsten-arc welding torch supports an electrode at its center while enabling the viewing of the weld area along the torch axis. The gas torch accommodates a lens and optical fibers — all part of a vision system for a welding robot. The main component of the torch is the optical body. The optical body includes openings for coaxial viewing and support, electrical contact, and heat removal from the electrode, which is held by a collet screwed into the hub of the spoked structure. (See page 68).

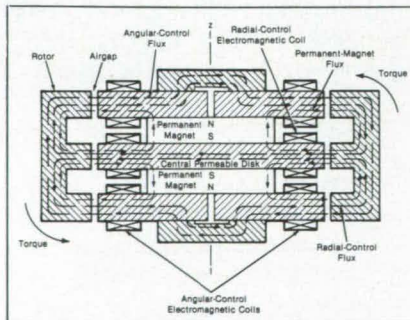

Magnetic Bearing With Radial and Angular Control

An active magnetic bearing stably levitates its rotor against radial (lateral) and axial motion and points the rotor axis in a controllable direction, yet allows the rotor to turn freely about its own axis. As in other magnetic-bearing systems, the rotor is the only moving part, and the absence of mechanical contact between the rotor and the stator assures long life.

The adjustable magnetic bearing would be particularly useful in high-speed rotating devices, robotic joints, and supports for optical elements. (See page 62).

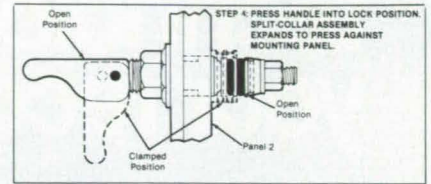

Quick-Release Panel Fastener

A quick-release fastener for panels can be actuated with just one hand. The new panel fastener is a self-contained unit that extends through congruent holes in the two panels to be joined. The unit contracts to clamp the panels together and expands to release them. (See page 44).

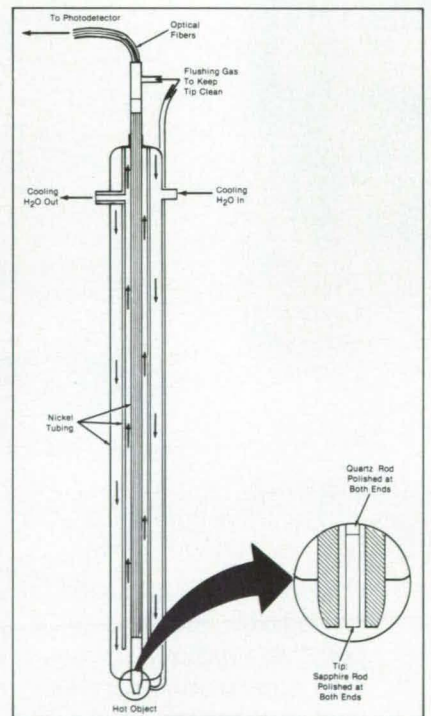

Water-Cooled Optical Thermometer

A water-cooled optical probe measures the temperature of a nearby radiating object. It is intended primarily for use in a silicon-growing furnace for measuring and controlling the temperatures of the silicon ribbon, meniscus, cartridge surfaces, heaters, or other parts. Cooling water and flushing gas cool the fiber-optic probe and keep it clean. The fiber passes thermal radiation from the observed surface to a measuring instrument. (See page 30).

IS YOUR WEAK LINK LUBRICATION?

It might have been before we invented TUFOIL Compu-Lube, TUFOIL Lightning Grease, TUFOIL Gun-Coat, TUFOIL Lubit-8 and TUFOIL for engines!

AT LAST!

Lubrication catches
up with the
microcomputer
age!

Until the day
you eliminate all
moving parts,
lubrication is
your weak link.

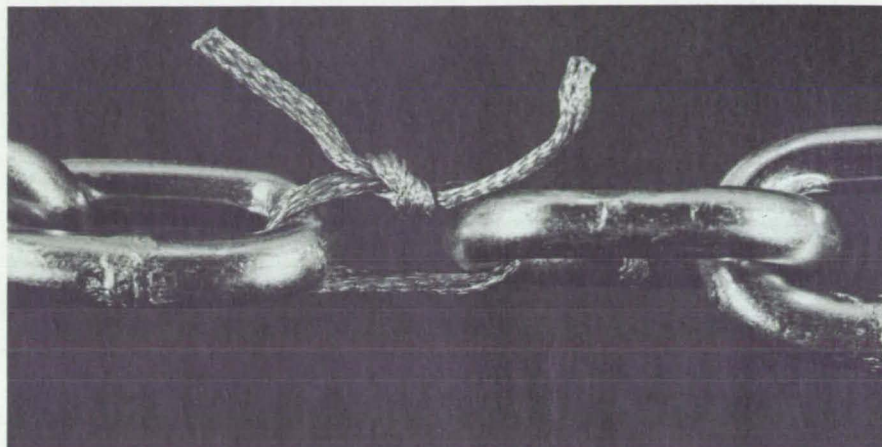

You may not think that anything as prosaic as lubrication oil has any role to play in these days of solid-state electronics.

But think again!

Amidst all that sophisticated computer wizardry, you have mechanical disk drives, daisy wheels, tractor feeds, robot arms, servos, strike solenoids, steppers, XY-recorders . . . all have precision bearings, gears or sliding mechanisms that can succumb to friction and bring down your whole system.

Lubrication is critical to continued smooth-running micro-computers; but until now, these most sophisticated devices in the history of technology have depended on thin films of oil based on technology as outdated as the vacuum tube.

To major oil companies, developing the right lubricant to be used in almost invisible amounts didn't promise sales big enough to fund their research efforts. Fortunately, at Fluoramics, we were already producing TUFOIL—a lubricant so advanced that it does for the science of lubrication what the transistor did for electronics.

For the past 15 years, we have been inventing and patenting special lubricants based on PTFE (Teflon® or Fluon®) dispersions. You may have seen one of them marketed as TUFOIL, an engine oil additive. Laboratory tests show extraordinarily low friction and wear with our products. Six U.S. Patents have been granted so far to protect our technological break-throughs . . . more are pending.

Tests on TUFOIL by the U.S. Government's National Bureau of Standards confirmed it has a coefficient of friction of only .029 (other independent labs show it to be even lower, under different test conditions). TUFOIL proved to have lower friction than teflon alone (.04) and one-third the value of diamond on diamond (.06) (Handbook data). The magnitude of difference between TUFOIL and other available oils is spectacular.



Your reputation and success depends on the lubricant you use. Why risk everything with anything less than the best.

OEM's all over the world are using TUFOIL products to make machines run better, smoother and last longer.

See NASA Tech Briefs (Nov./Dec. 1986 issue) for additional details.

Call for prices and information.

TUFOIL . . .
a drop of
security.™

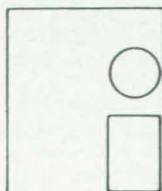

Fluoramics Inc.

103 PLEASANT AVENUE,
UPPER SADDLE RIVER, NJ 07458
201-825-8110

FLUON® is reg. T.M. of ICI Americas Inc.
TEFLON® is reg. T.M. of duPont®
TUFOIL® is reg. T.M. of Fluoramics

HOW YOU CAN BENEFIT FROM NASA'S TECHNOLOGY UTILIZATION SERVICES



If you're a regular reader of TECH BRIEFS, then you're already making use of one of the low- and no-cost services provided by NASA's Technology Utilization (TU) Network. But a TECH BRIEFS subscription represents only a fraction of the technical information and applications/engineering services offered by the TU Network as a whole. In fact, when all of the components of NASA's Technology Utilization Network are considered, TECH BRIEFS represents the proverbial tip of the iceberg.

On the following pages, we've outlined NASA's TU Network—named the participants, described their services, and listed the individuals you can contact for more information relating to your specific needs. We encourage you to make use of the information, access, and applications services offered by NASA's Technology Utilization Network. You can save time and money by doing so.

HOW YOU CAN UTILIZE NASA'S Industrial Applications Centers

A nationwide network offering a broad range of technical services, including computerized access to over 100 million documents worldwide.

You can contact NASA's network of Industrial Applications Centers (IACs) for assistance in solving a specific technical problem or meeting your information needs. The "user friendly" IACs are staffed by technology transfer experts who provide computerized information retrieval from one of the world's largest banks of technical data. Nearly 500 computerized data bases, ranging from NASA's own data base to Chemical Abstracts and INSPEC, are accessible through the nine IACs, which are located throughout the nation. The IACs also offer technical consultation services and/or linkage with other experts in the field.

You can obtain more information about these services by calling or writing the nearest IAC. User fees are charged for IAC information services.

Aerospace Research Applications Center (ARAC)

Indianapolis Center for Advanced Research
611 N. Capitol Avenue
Indianapolis, IN 46204
Dr. F. Timothy Janis, Director
(317) 262-5003

Kerr Industrial Applications Center (KIAC)

Southeastern Oklahoma State University
Station A, Box 2584
Durant, OK 74701
Tom J. McRorey, Director
(405) 924-6822

NASA Industrial Applications Center

823 William Pitt Union
University of Pittsburgh
Pittsburgh, PA 15260
Paul A. McWilliams, Executive Director
(412) 648-7000

NASA/Southern Technology Applications Center

State University System of Florida
307 Weil Hall
Gainesville, FL 32611
J. Ronald Thornton, Director
(904) 392-6760

NASA/UK Technology Applications Center

University of Kentucky
109 Kinkead Hall
Lexington, KY 40506-0057
William R. Strong, Director
(606) 257-6322

NERAC, Inc.

Mansfield Professional Park
Storrs, CT 06268
Daniel U. Wilde, President
(203) 429-3000

North Carolina Science and Technology Research Center (NC/STRC)

Post Office Box 12235
Research Triangle Park, NC 27709
J. Graves Vann, Jr., Director
(919) 549-0671

Technology Application Center (TAC)

University of New Mexico
Albuquerque, NM 87131
Stanley A. Morain, Director
(505) 277-3622

NASA Industrial Applications Center (WESRAC)

University of Southern California
Research Annex
3716 South Hope Street
Room 200
Los Angeles, CA 90007
Radford G. King, Acting Director
(213) 743-6132
(800) 642-2872 (CA only)
(800) 872-7477 (toll-free US)

If you represent a public sector organization with a particular need, you can contact NASA's Application Team for technology matching and problem solving assistance. Staffed by professional engineers from a variety of disciplines, the Application Team works with public sector organizations to identify and solve critical problems with existing NASA technology.

Technology Application Team

Research Triangle Institute
P.O. Box 12194
Research Triangle Park, NC 27709
Doris Rouse, Director
(919) 541-6980

A SHORTCUT TO SOFTWARE:

COSMIC[®]

An economical source of computer programs developed by NASA & other gov't. agencies.

Software developed by the U.S. government may be applicable to your needs. To tap this valuable resource, contact COSMIC, NASA's Computer Software Management and Information Center. Approximately 1400 computer programs and related documentation comprise the current library. New and updated programs are announced regularly in NASA Tech Briefs' Computer Programs section, and COSMIC publishes an annual software catalog.

More information about COSMIC's services can be obtained by calling or writing:

COSMIC[®]
Computer Services Annex
University of Georgia
Athens, GA 30602
John A. Gibson, Director
(404) 542-3265

HOW YOU CAN ACCESS TECHNOLOGY TRANSFER SERVICES AT NASA FIELD CENTERS:

Technology Utilization Officers & Patent Counsels

Each NASA Field Center has designated a Technology Utilization Officer and a Patent Counsel to facilitate technology transfer between NASA and the private sector.

If you need further information about new technologies presented in NASA Tech Briefs, you should request the Technical Support Package (TSP) that accompanies the brief. In the event that a TSP is not available, you can contact the Technology Utilization Officer at the NASA Field Center that sponsored the research. He can arrange for expert assistance in applying the technology by putting you in touch with the people who developed it.

If you want additional information about the patent status of a particular technology or are interested in licensing a NASA invention, contact the Patent Counsel at the NASA Field Center that sponsored the research. Be sure to refer to the NASA reference number at the end of the tech brief.

Ames Research Center

Technology Utilization Officer:

Laurance A. Milov
Mail Code 204-10
Moffett Field, CA 94035
(415) 694-5761

Patent Counsel:

Darrell G. Brekke
Mail Code 200-11
Moffett Field, CA 94035
(415) 694-5104

Goddard Space Flight Center

Technology Utilization Officer:

Donald S. Friedman
Mail Code 702-1
Greenbelt, MD 20771
(301) 286-6242

Patent Counsel:

John O. Tresansky
Mail Code 204
Greenbelt, MD 20771
(301) 286-7351

Lyndon B. Johnson Space Center

Technology Utilization Officer:

Dean C. Glenn
Mail Code EA4
Houston, TX 77058
(713) 483-3809

Patent Counsel:

Edward K. Fein
Mail Code AL3
Houston, TX 77058
(713) 483-4871

John F. Kennedy Space Center

Technology Utilization Officer:

Thomas M. Hammond
Mail Stop PT-TPO-A
Kennedy Space Center, FL 32899
(305) 867-3017

Patent Counsel:

James O. Harrell
Mail Code PT-PAT
Kennedy Space Center, FL 32899
(305) 867-2544

Langley Research Center

Technology Utilization Officer:

John Samos
Mail Stop 139A
Hampton, VA 23665
(804) 865-3281

Patent Counsel:

Howard J. Osborn
Mail Code 279
Hampton, VA 23665
(804) 865-3725

Lewis Research Center

Technology Utilization Officer:

Daniel G. Soltis
Mail Stop 7-3
21000 Brookpark Road
Cleveland, OH 44135
(216) 433-5567

Patent Counsel:

Gene E. Shook
Mail Code 60-2
21000 Brookpark Road
Cleveland, OH 44135
(216) 433-5753

Jet Propulsion Laboratory

Technology Utilization Manager:

Norman L. Chalfin
Mail Stop 201-110
4800 Oak Grove Drive
Pasadena, CA 91109
(818) 354-2240

NASA Resident Office-JPL

Technology Utilization Officer:

Gordon S. Chapman
Mail Stop 180-801
4800 Oak Grove Drive
Pasadena, CA 91109
(818) 354-4849

Patent Counsel:

Paul F. McCaul
Mail Code 180-801
4800 Oak Grove Drive
Pasadena, CA 91109
(818) 354-2734

George C. Marshall Space Flight Center

Technology Utilization Officer:

Ismail Akbay
Code AT01
Marshall Space Flight Center,
AL 35812
(205) 544-2223

Patent Counsel:

Leon D. Wofford, Jr.
Mail Code CC01
Marshall Space Flight Center,
AL 35812
(205) 544-0024

National Space Technology Laboratories

Technology Utilization Officer:

Robert M. Barlow
Code GA-10
NSTL Station, MS 39529
(601) 688-1929

NASA Headquarters

Technology Utilization Officer:

Leonard A. Ault
Code IU
Washington, DC 20546
(202) 453-1920

Assistant General Counsel for Patent Matters: Robert F. Kempf
Code GP
Washington, DC 20546
(202) 453-2424

IF YOU HAVE A QUESTION . . .

NASA Scientific & Technical Information Facility

If you have a general or specific question about NASA's Technology Utilization Network or its services and documents, you can contact the STI facility for assistance. The STI staff can answer your questions, supply documents and provide referrals to meet your needs. You can use the feedback card in this issue to contact STI directly.

NASA Scientific and Technical Information Facility

Technology Utilization Office
P.O. Box 8757
BWI Airport, MD 21240
Walter M. Heiland, Manager
(301) 859-5300, Ext. 242, 243

Electronic Components & Circuits

Vibration-Resistant Support for Halide Lamps

The lamp envelope is protected against breakage.

Lyndon B. Johnson Space Center, Houston, Texas

A support cushions a metal halide arc lamp against vibration and allows it to expand and contract as it heats or cools. The support replaces one that tended to crack the quartz lamp envelope by exerting stresses during vibration and thermal cycles.

Previously, the spider arms at the top were brazed directly to the anode lead (see top of figure). When the lamp was

vibrated, the arms transmitted tension and shear forces that fractured the quartz arms, and the halide gases in the lamp escaped. The bottom was supported by a beryllium/copper finger stock, which also served as an electrical connection to the cathode. Eventually the stock was annealed by the heat of the lamp. At temperatures over 450 °C, the stock lost its spring and made only inter-

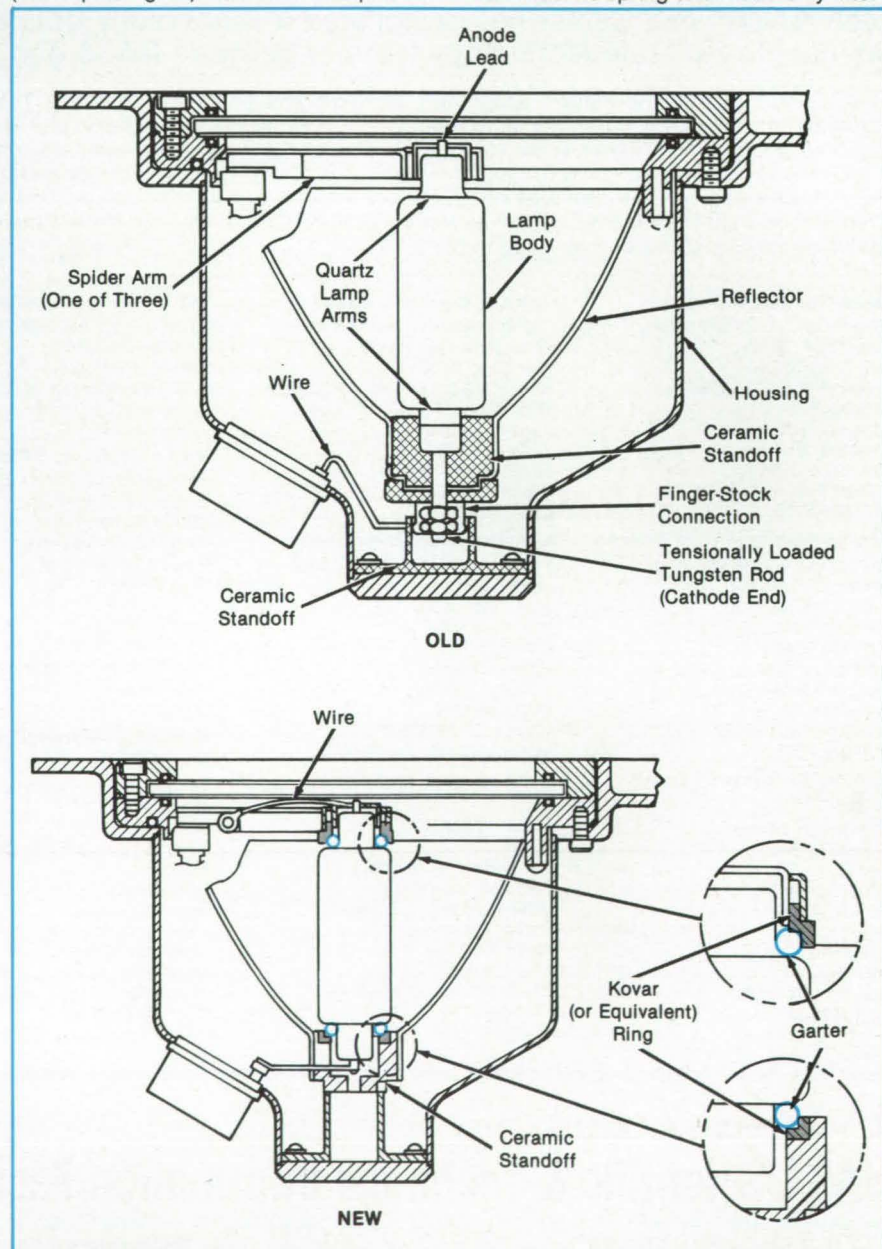

Old and New Mounts for a halide arc lamp are sealed in a housing with a parabolic reflector and a quartz window. The new version, however, supports the lamp with compliant garters instead of a rigid brazed joint at the top and a dimensionally unstable finger stock at the bottom.

Hardware, Techniques, and Processes

- 20 Vibration-Resistant Support for Halide Lamps
- 22 In-Vacuum Dissociator for Atomic-Hydrogen Masers
- 23 Measuring Thicknesses of Wastewater Films
- 24 Two-Range Electrical Thermometer

Books and Reports

- 24 Theoretical Efficiencies of Microwave Diode Triplers
- 25 MOSFET's for Cryogenic Amplifiers

THE FIRST NAME IN DIGITAL SCOPES

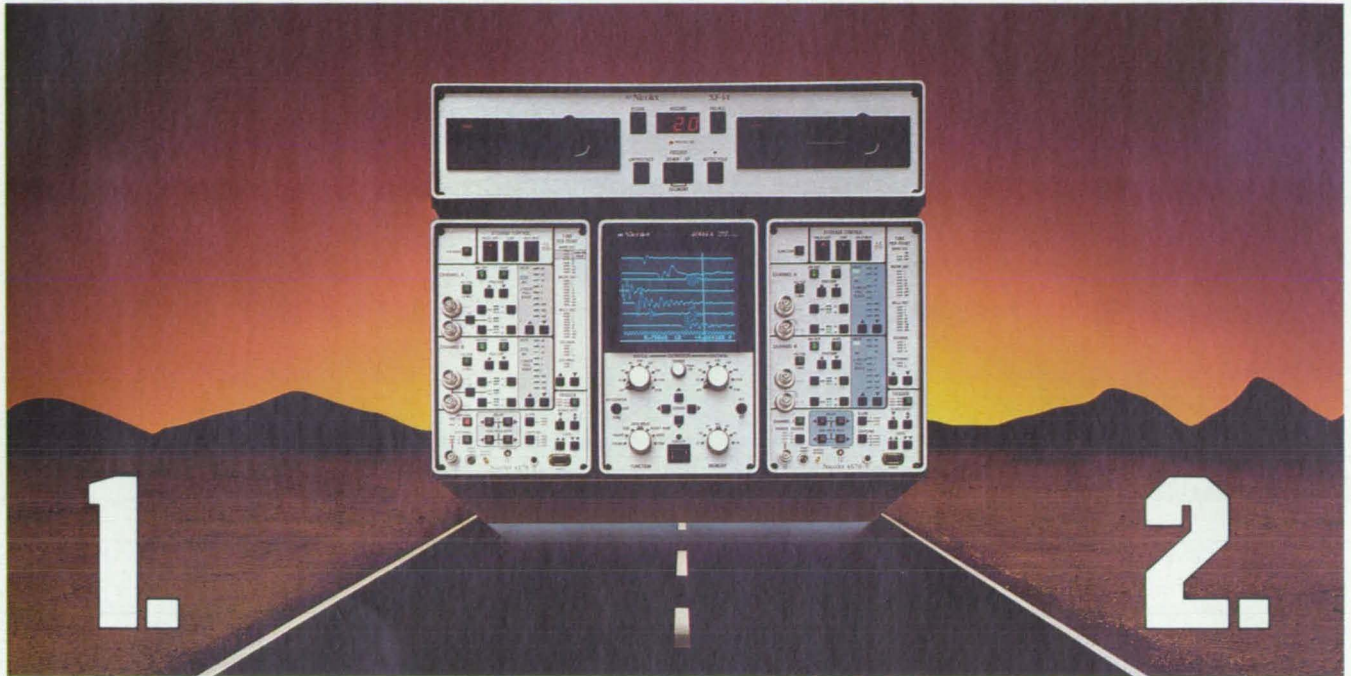

TWO DIGITAL SCOPES IN ONE.



The Acquisition.

With sweep speeds from days to nanoseconds and resolution up to 15 bits, the 4094 digital 'scope can capture the most elusive signals. Every plug-in has 16K of memory, viewable trigger set-up and independent pre- or post-trigger delay on each channel. Signal averaging is standard and our latest 10 MHz/12-bit plug-in even offers real time manipulation of the incoming signals. With two plug-ins the 4094 can record four channels simultaneously. Or even monitor two slow signals and capture high speed glitches at the same time. All under computer control or via manual operation: whatever your application demands.

The Analysis.

Expand and examine any waveform feature in detail. Use the dual cursors and numerics to measure the time or voltage of any point. Compare live or stored waveforms with each other or with pre-recorded references. Store signals on disk manually or automatically. Use pushbutton programs to manipulate the data or send it to your computer via GPIB or RS232 interface. Complete your report with a hardcopy plot using the XY/YT recorder or digital plotter outputs.

First Time, Everytime.

Don't miss important data because of set-up errors. From the World's first in 1973 to the latest models, Nicolet 'scopes are easy to use. Find out how they can be the quickest solution to your signal problems. For more information call 608/273-5008, or write Nicolet Test Instruments Division, P.O. Box 4288, 5225 Verona Road, Madison, WI 53711-0288.

NTE Nicolet

Circle Reader Action No. 350

mittent contact during vibration.

The new support holds the lamp with a pair of tungsten-coil garters — one at the anode arm of the lamp and the other at the cathode arm (see bottom of figure). The lamp floats within the garter restraints. The garters absorb vibrations and accommodate the thermal expansion and contraction of the lamp. They apply compression forces, which the quartz lamp arms can withstand better than they can withstand tension or shear.

The garters are held by Kovar (or equivalent) Fe/Ni/Co alloy rings. Three spider arms support the top (anode) ring. The bottom (cathode) ring rests on a ceramic standoff.

The garters are made of tungsten wire of 0.010-in. (0.25-mm) diameter, wound into a helix of about 0.1-in. (2.5-mm) diameter. A length of the helix is cut to size and wrapped around the lamp arm. Four or five turns are entwined at the ends so that the coiled wire encircles the

arm snugly.

The electrical connections to the lamp leads are twisted pairs of nickel wire 0.020 in. (0.51 mm) in diameter. A wire pair is brazed to the tungsten lead at the lamp end and is screwed and soldered by a lug to a connector pin at the other end.

This work was done by John Kiss of ILC Technology, Inc., for Johnson Space Center. No further documentation is available.
MSC-20523

In-Vacuum Dissociator for Atomic-Hydrogen Masers

Thermal control and vacuum sealing is achieved while contamination is avoided.

Marshall Space Flight Center, Alabama

A simple, relatively inexpensive molecular-hydrogen dissociator (see figure) for atomic-hydrogen masers can be used on Earth or in the vacuum of space. No air cooling is required, and the absence of elastomeric O-ring seals prevents contamination.

The dissociator splits hydrogen molecules into single hydrogen atoms and launches the atoms in a well-collimated beam into the vacuum system of the maser. Heretofore, the dissociator has been the most troublesome and unreliable component of the maser: the interior surfaces of the dissociator have been prone to contamination, which causes the atomic hydrogen to recombine, and to overheating by dissipated dissociation energy.

The forced-air cooling normally used to control the dissociator temperature cannot be used in the vacuum of space because such an arrangement requires a hermetically-sealed heat exchanger and a mechanical blower. Another problem has been the need for mechanically strong, noncontaminating, vacuum-tight seals between the glass dissociator enclosure and the metal vacuum system. Glass-to-metal seals are bulky, fragile, and subject to stress fracture. Elastomer seals are sources of contamination and deteriorate with age and upon exposure to radiation.

In the improved dissociator (see figure), the problem of thermal control and vacuum sealing has been solved by placing the dissociator entirely in the vacuum system. The metal and glass parts are joined simply by polishing the two mating surfaces and holding them together with moderate force: there is no need for a vacuum-tight joint.

The hydrogen gas is excited via a 3-turn coil coaxially surrounding the cylindrical glass dissociator envelope. The coil is matched to a 50-ohm coaxial transmission line by adding a 0-to-15-pF adjustable ca-

pacitor in series to make a simple series-resonant circuit. The frequency of the generator and the capacitor are adjusted to

give an optimal match between the radio-frequency power generator and the coil.

Because the coil is not in contact with

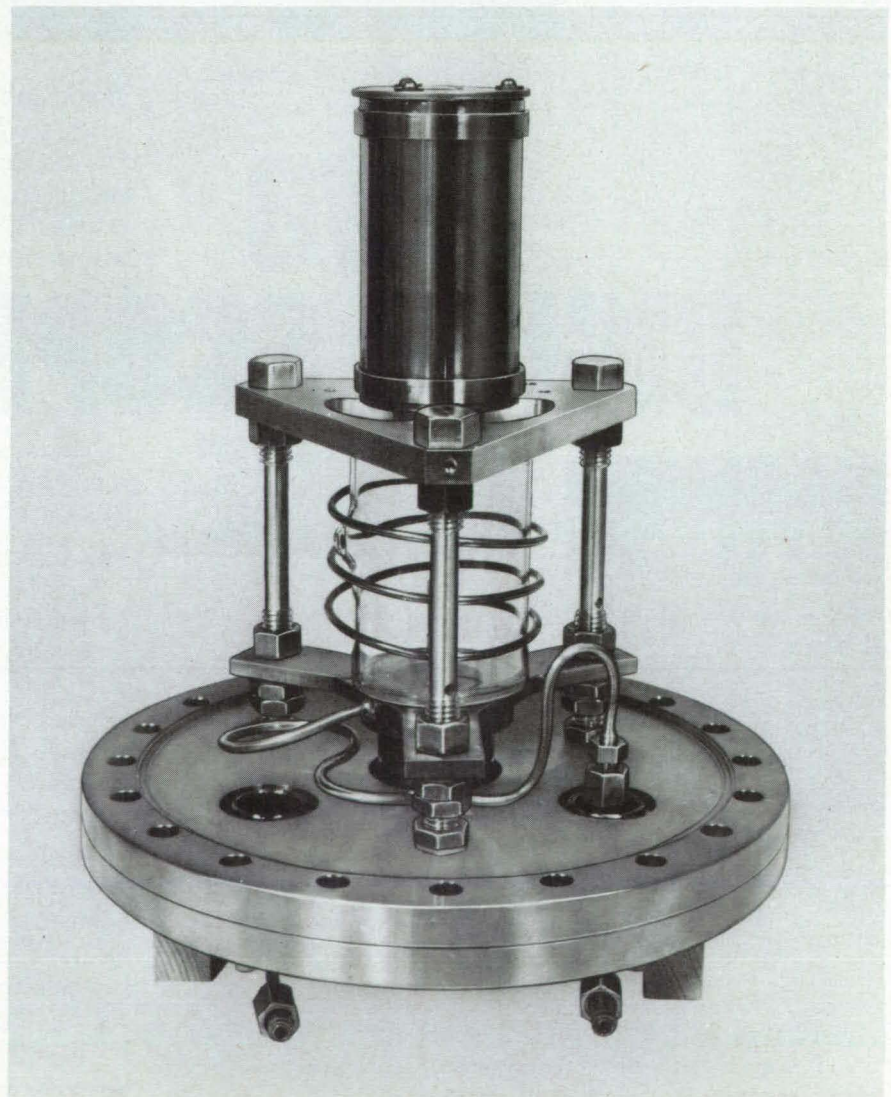

In the **In-Vacuum Dissociator** for atomic hydrogen masers, hydrogen gas in the glass dissociator is dissociated by a radio-frequency signal transmitted from the surrounding 3-turn coil. Heat in the glass is conducted away by the contacting metal surfaces.

the glass, the heat from the coil is dissipated to the metal vacuum envelope via the coaxial feedthrough. Heat in the glass, resulting partly from dielectric loss in the glass but mostly from bombardment by electrons in the plasma, is conducted to the metal vacuum envelope via the aluminum mounting structure and the heavy copper gas-inlet line.

The operation of the dissociator requires less than 5 W of radio-frequency power at an excitation frequency of about 67 MHz. Once the plasma has been excited, optimum coupling can be obtained at a slightly lower frequency (approximately 66.5 MHz), owing to the dielectric loading of the plasma.

This work was done by Robert F. C.

Vessot of the Smithsonian Institution for Marshall Space Flight Center. No further documentation is available.

Inquiries concerning rights for the commercial use of this invention should be addressed to the Patent Counsel, Marshall Space Flight Center [see page 19]. Refer to MFS-26007.

Measuring Thicknesses of Wastewater Films

A sensor resists excessive film buildup.

Lyndon B. Johnson Space Center, Houston, Texas

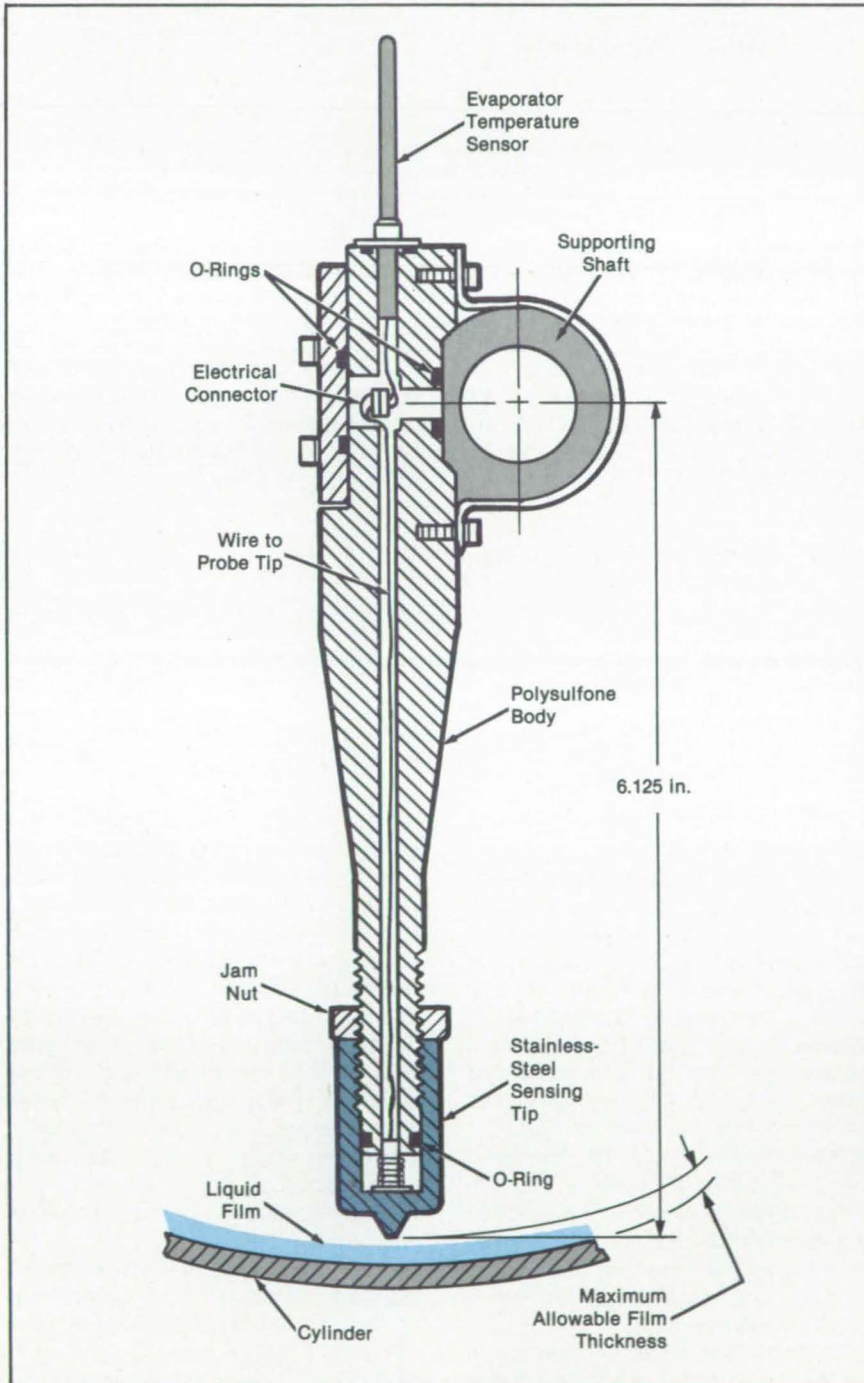

Mounted on a shaft in a rotating cylinder, the liquid-thickness sensor extends toward the cylinder wall so that its tip almost touches. The sensor body also accommodates a probe that measures the temperature of the evaporated water in the cylinder.

A sensor determines when the thickness of a film of electrically conductive wastewater on a rotating evaporator drum exceeds a preset value. The sensor is a simple electrical probe that makes contact with the liquid surface. It is made of materials that are resistant to chemicals in the liquid.

The sensor was developed for equipment that reclaims potable water from astronauts' urine wastewater. The equipment is based on vapor-compression distillation, in which a film of the pretreated wastewater flows over the internal surface of a rotating cylinder, as in a centrifuge. Water evaporates from the film, leaving unwanted minerals behind. The vapor is then condensed.

If the liquid film becomes too thick, water production drops because less heat is transferred from the cylinder wall to the film surface. More seriously, wastewater would eventually accumulate in the cylinder, flood it, and perhaps spill into the product side of the equipment. The film-thickness sensor helps to prevent these occurrences.

The sensor consists of a passivated stainless-steel sensing tip in a polysulfone body. Electrical wiring and connections are hermetically sealed within the body (see figure). The sensing tip is positioned a predetermined distance [usually 0.06 inch (1.5 millimeter)] from the surface containing the film. When the liquid thickness equals or exceeds the distance between the surface and the tip, the liquid touches the tip, thereby closing an electrical circuit between the tip and the surface. This activates controls that cause the removal of the excess liquid.

The materials selected for the sensor are immune to chemical attack from the urine in the wastewater as well as from the sulfuric acid used to pretreat it. In addition, the geometry and materials of the tip and body prevent the sensor from becoming fouled by mineral residue.

This work was done by Franz H. Schubert and Ronald J. Davenport of Life Systems, Inc., for Johnson Space Center. For further information, Circle 18 on the TSP Request Card. MSC-20915

Two-Range Electrical Thermometer

A thermocouple and a resistance thermometer expand the thermometer scale.

Marshall Space Flight Center, Alabama

A temperature-monitoring circuit employs two types of sensors so that it can measure over two temperature ranges, covering -450 to $2,800^\circ\text{F}$ (-268 to $1,538^\circ\text{C}$). A platinum resistance temperature detector and a (platinum/rhodium)/platinum thermocouple (Instrument Society of America type S) are included in the circuit.

The platinum resistance temperature detector is a bridge circuit that includes three extension wires connected to the temperature-sensing resistor (see figure). Ordinarily, all three wires are made of platinum. In the new circuit, however, one of the wires is made of an alloy of platinum with 10 percent rhodium. A thermocouple is thus formed where this wire joins one end of the temperature-sensing resistor. Depending on the temperature range to be monitored, a switch is turned to connect either the bridge circuit or the thermocouple circuit.

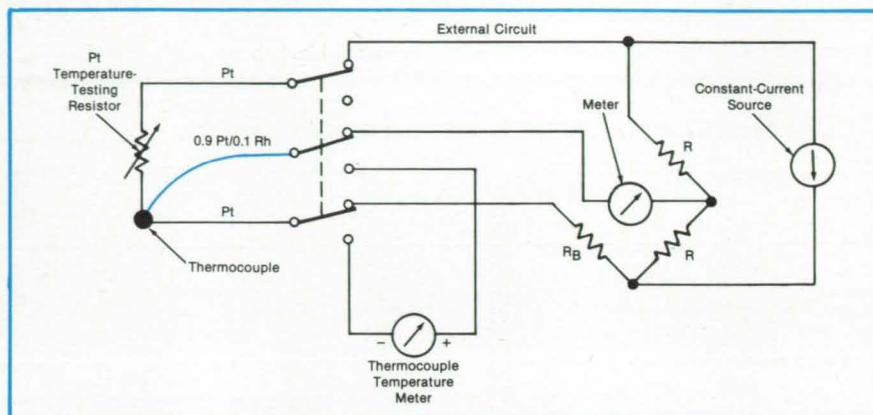

The Switch Can Be Thrown up to connect a platinum resistance temperature detector or down to connect a (platinum/rhodium)/platinum thermocouple to a meter. The thermocouple is an integral part of the platinum resistance temperature detector wiring.

This work was done by William F. Bridges of United Technologies Corp. for Marshall Space Flight Center. For further information, Circle 71 on the TSP Request Card.

Inquiries concerning rights for the commercial use of this invention should be addressed to the Patent Counsel, Marshall Space Flight Center [see page 19]. Refer to MFS-28145.

Books and Reports

These reports, studies, and handbooks are available from NASA as Technical Support Packages (TSP's) when a Request Card number is cited; otherwise they are available from the National Technical Information Service.

Theoretical Efficiencies of Microwave Diode Triplers

Simulations are conducted for 300- to 900-GHz units.

A report discusses computer simulations of 300- to 900-GHz triplers using nonideal GaAs Schottky diodes operating in the varistor mode. The nonlinear boundary-value problem posed by the diode state equations cannot be solved in closed form. Consequently, such computer simulations are needed to

optimize the tripler configuration and operating conditions.

Even though varistors have series resistance, they are more efficient than varactors at the frequencies of interest because they have greater cut-off frequencies. Therefore, in this analysis the diode is considered to operate in the forward-bias (varistor) mode. The mathematical model of the tripler includes the diode series resistance, the dc bias current, the pump-oscillator input, the harmonic outputs, the voltage-dependent portion of the diode resistance, the junction capacitance (which is approximated as constant at the zero-bias value), and the network of impedances representing the diode mount.

To facilitate an iterative solution, the model also includes a lossless transmission line at the interface between the diode junction and the mount. The transmission-line length is set to an in-

tegral number of wavelengths at the pump frequency (300 GHz) so that the steady-state waveforms remain unaffected by this artifice. A dynamic boundary condition poses an unbalanced transmission-line system, for which the settling behavior is well defined. Part of an initial wave propagating toward the diode is reflected back toward the mount, part of the back-reflected wave is reflected by the mount toward the diode, and so forth. When the waves in both directions have settled down to equal magnitudes, the steady-state solution has been attained.

At the beginning of a computation, the pump power and diode bias are set at the desired operating levels. The mounting-network impedances are set to arbitrary design values at the harmonics to be considered. The computer then iterates the reflection cycle until the system converges to the oper-

ating point. At the pump frequency, the computer adjusts the mount impedance so that the pump power is completely absorbed. Thus, the pump-frequency impedance becomes an output of the program, and each operating-point calculation represents a different mount design.

A series of calculations was done using a set of parameters typical of a state-of-the-art mixing diode. The pump power was set at 40 mW, a level representative of the outputs of carcinotrons at 300 GHz. The dc bias current was systematically varied from run to run over the range of 3 to 25 mA. In runs corresponding to the optimum value of the imaginary component of mount impedance at 900 GHz, the maximum computed efficiency was about 7 percent. (An ideal varistor would exhibit about 11 percent efficiency.)

This work was done by Margaret A. Frerking and Katherine Benson of Caltech for NASA's Jet Propulsion Laboratory. To obtain a copy of the report, "Theoretical Efficiency for Triplers Using Non-Ideal Varistor Diodes at Submillimeter Wavelengths," Circle 60 on the TSP Request Card. NPO-16749

MOSFET's for Cryogenic Amplifiers

A study seeks ways to build transistors that function effectively at liquid-helium temperatures.

A report discusses the physics of metal-oxide/semiconductor field-effect transistors (MOSFET's) and the performances of these devices at cryogenic temperatures. MOSFET's are useful in highly sensitive cryogenic preamplifiers for infrared astronomy.

Astronomers would like to improve the signal-to-noise ratios of receivers by operating the preamplifiers at the same temperature as the detectors — as low as 1.4 K. Currently available MOSFET's are designed to operate primarily at room temperature but perform well at temperatures as low as 60 K. Below that, however, the performance degrades rapidly as the temperature decreases.

The report discusses electrical measurements of p-channel, enhancement-mode MOSFET's over the temperature range from 300 to 4.3 K. Current-versus-voltage measurements were made as a function of temperature on MOSFET's on integrated-circuit chips, each of which contained four transistors. The average channel lengths of the four transistors on

each chip were 3.27, 5.68, 8.37, and 11.39 μm , respectively. The devices were made on (1,1,1)-plane silicon wafers doped with phosphorus to a level of $2.5 \times 10^{16} \text{ cm}^{-3}$. The p⁺ source and drain wells were formed by boron diffusion.

The devices with shorter channels performed better in the range of 4 to 20 K than those with longer channels. Additional testing will be done down to 1.4 K, with various channel-dopant levels.

The report explains carrier freeze-out, which is the principal mechanism that degrades performance at low temperatures. It discusses how the mechanism might be circumvented by increasing im-

purity concentrations. MOSFET's with p-channels can be made in p-type silicon wafers so that the gap between acceptor and valence bands is much less than 0.04 eV. Such devices will not operate at room temperature but may operate well at very low temperatures.

This work was done by Robert DeHaye of Marshall Space Flight Center and Carl A. Ventrice of Tennessee Technological University. To obtain a copy of the report, "Electrical Performance of Semiconductor Devices at Cryogenic Temperatures," Circle 32 on the TSP Request Card.

MFS-27111

From The Macro- To The Micro-Environment,



We Test Out.

The challenge to shape the future while protecting the present has been successfully met for over two decades by National Technical Systems on behalf of the U.S., state and local governments, and major corporations. They've relied on our testing expertise in areas

like aerospace, avionics, energy, transportation, communications, and the environment. To all our projects we bring unbeatable technical resources and the unrelenting dedication of our people to making the unknown not only knowable, but manageable.



National
Technical
Systems

Call National Technical Systems.
In the west (714) 879-6110.
In the east (617) 263-2933.

Or write NTS, 533 Main St., Acton, MA 01720
or 1536 E. Valencia Dr., Fullerton, CA 92631.

Circle Reader Action No. 358

Electronic Systems

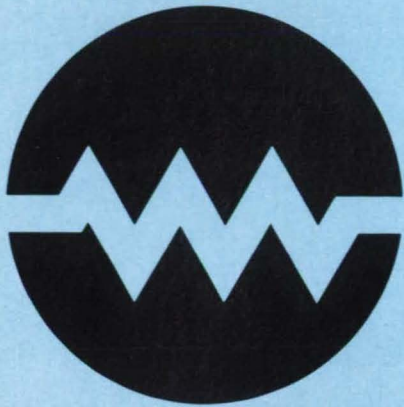

Hardware, Techniques, and Processes

26 Radar Time-Base and Pseudonoise Generator

Books and Reports

28 VLBI System for Satellite Navigation

29 Design Considerations for High-Speed Control Systems

Radar Time-Base and Pseudonoise Generator

Long pulses are effectively compressed by a pseudonoise technique.

NASA's Jet Propulsion Laboratory, Pasadena, California

A computer-controlled, polynomial-driven time-base and pseudonoise generator (see figure) will enable a radar system to achieve a range resolution of about 80 m with radar pulses of 1-s duration. Normally, an unmodulated 1-s pulse would have a relatively coarse range resolution of several thousand kilometers. However, this radar system effectively compresses a modulated pulse into one of the 100-ns pseudonoise-modulating pulses. Intended primarily for use with interplanetary radar, the time-base/pseudonoise concept may also prove useful in test instruments or in time-base correction for video recording.

As in other spread-spectrum systems of the same general type, the pseudonoise modulation is derived from maximal-length binary codes that yield an optimum correlation function with minimum side lobes and with the lowest possible signal-to-clutter ratio. The code sequence is specified by a polynomial that is implemented by feedback shift registers. In the radar receiver, a pseudonoise generator similar to that of the transmitter is used for the coherent detection (cross correlation) of the received modulated pulses.

In the return signal, both the carrier frequency and the modulation are expanded or contracted in time by the Doppler shift caused by the relative motion between the station and the target. For coherent

detection, it is necessary to vary the time base of the receiver pseudonoise generator to match that of the pseudonoise modulation of the return signal.

In the receiver, a 50-MHz clock is synchronized with the precise 1-s transmitter pulses. The time base (shifting rate) for the shift register in the pseudonoise generator is set by the baud-rate generator, which operates on the 50-MHz clock signal to produce a clock signal of 10 MHz plus or minus a small increment. This skewed clock signal is used in tracking the time shifts in the return signal caused by the relative motion between the station and the target.

In the code-generator portion of the pseudorandom-noise generator, the feedback taps on the shift register are selected for the desired code by a programmable read-only memory. Codes up to 2^{24} in length are available. A word detector and a phase counter are used to determine the precise elapsed time between the most recent 1-s pulse and the detection of a word. The starting time of the receiver pseudonoise signal is set accordingly. The receiver pseudonoise signal tracks the correct phase within ± 20 ns over the entire code length.

This work was done by Stanley S. Brokl of Caltech for NASA's Jet Propulsion Laboratory. For further information, Circle 5 on the TSP Request Card. NPO-16361

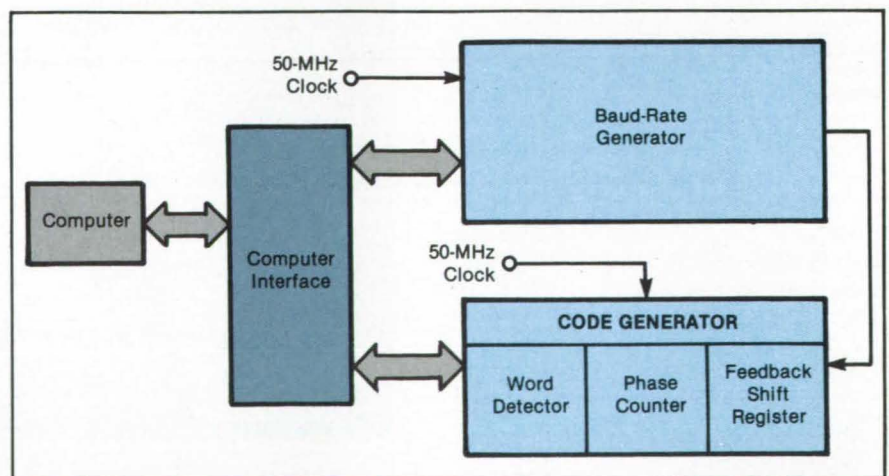

The **Polynomial-Driven Time-Base and Pseudonoise Generator** produces a polynomial binary code sequence in a receiver to track that of the received signal within 20 ns.

"State of the art" is a state of mind at Data-Control Systems

DCS has built its reputation on reliability and quality in the field of telemetry equipment. Since joining the CompuDyne family of companies, our access to additional funds, personnel and technology has further enhanced that reputation by fueling an aggressive new products development program.

Last year DCS launched the PCM Adaptive Bit Synchronizer and the Universal FM Demodulator. This year will see the introduction of a new Bit Synchronizer, a new PCM Decommutator, a Tunable QPSK/BPSK Demodulator/Synchronizer and other innovative products employing the latest in DSP, PLA, and LCA technology.

At DCS, "state of the art" not only describes our products but our state of mind. Our commitment to "take it to the edge." Our determination to take the lead. And keep it.

DATA-CONTROL SYSTEMS/QSC

CompuDyne Defense Electronics Group

1455 Research Boulevard
Rockville, MD 20850
(301) 279-8798
TWX (710) 828-9785

8291 Westminster Ave., Suite 150
Westminster, CA 92683
(714) 894-4471
TWX (910) 596-1802

Circle Reader Action No. 371

Books and Reports

These reports, studies, and handbooks are available from NASA as Technical Support Packages (TSP's) when a Request Card number is cited; otherwise they are available from the National Technical Information Service.

VLBI System for Satellite Navigation

A system is described, and its anticipated performance is analyzed.

A report discusses a proposed low cost very-long-baseline interferometric (VLBI) system dedicated for use with the Tracking and Data Relay Satellite System (TDRSS) in determining the orbits of user satellites. The theoretical accuracies of the orbits to be measured by the new system are compared with similar orbital determinations by other satellite-navigation systems, based on the anticipated state of the VLBI art in the year 1990.

Ideally, the VLBI system would include four 1-m antennas for each TDRS at the ends of orthogonal 6,000-km baselines, with the TDRS centered above the in-

tersection of the baselines. It is also possible to use three antennas at the corners of an equilateral triangle with the TDRS located above the centroid. The system would measure the differential one-way range to a satellite station from the two antennas at the opposite ends of each baseline, using quartz clocks with a system noise temperature of 300 K. A special receiver would be used to calibrate the ionospheric and clock offsets, using the dual L-band signal transmitted by the Global Positioning System (GPS) satellites. Calibrations would be performed at each differential one-way measurement.

One set of instrument errors of the proposed system is based on the capabilities of the portion of the GPS system scheduled to become available about now. A second set of errors is based on the assumed deployment, around the year 1990, of the complete 18-satellite GPS and the SERIES/X radiometric system of geodetic receivers for tracking satellites in low orbits around the Earth. The ephemeris error is assumed to be 5 meters in the supposed present system and is expected to decrease to less than 1 meter with the 1990 system.

The performance of the VLBI system was evaluated using the assumed instrument errors in an ideal four-antenna configuration. First, the TDRSS navigation ac-

curacy was assessed in terms of the maximum position error during a 24-hour period, assuming the acquisition of differential one-way ranges from both baselines every two hours. Next, error analyses were conducted for a Topex satellite in a circular orbit at an altitude of 1,330 km and an inclination of 65°, in which the predominant dynamic errors are expected to be due to the uncertainty of the geopotential field. Another analysis was conducted for a Space Shuttle at 280 km altitude and 28° inclination.

Based on the assumed 1990 VLBI system, the TDRSS orbit-determination accuracy is expected to improve by a factor of about 20. This translates into accuracy-improvement factors ranging from 3 to 10 for typical TDRSS users. Such error sources as instrument biases and uncertainties in station locations can be independently calibrated in the VLBI system. Other advantages of the VLBI system are that it is susceptible to evolutionary improvements without additions to the basic system elements, that it reduces the sampling frequency and the volume of tracking data for TDRSS navigation, and that the loading requirements on the TDRSS Multiple-Access forward link are reduced.

This work was done by Jordan M. Ellis of Caltech for NASA's Jet Propulsion

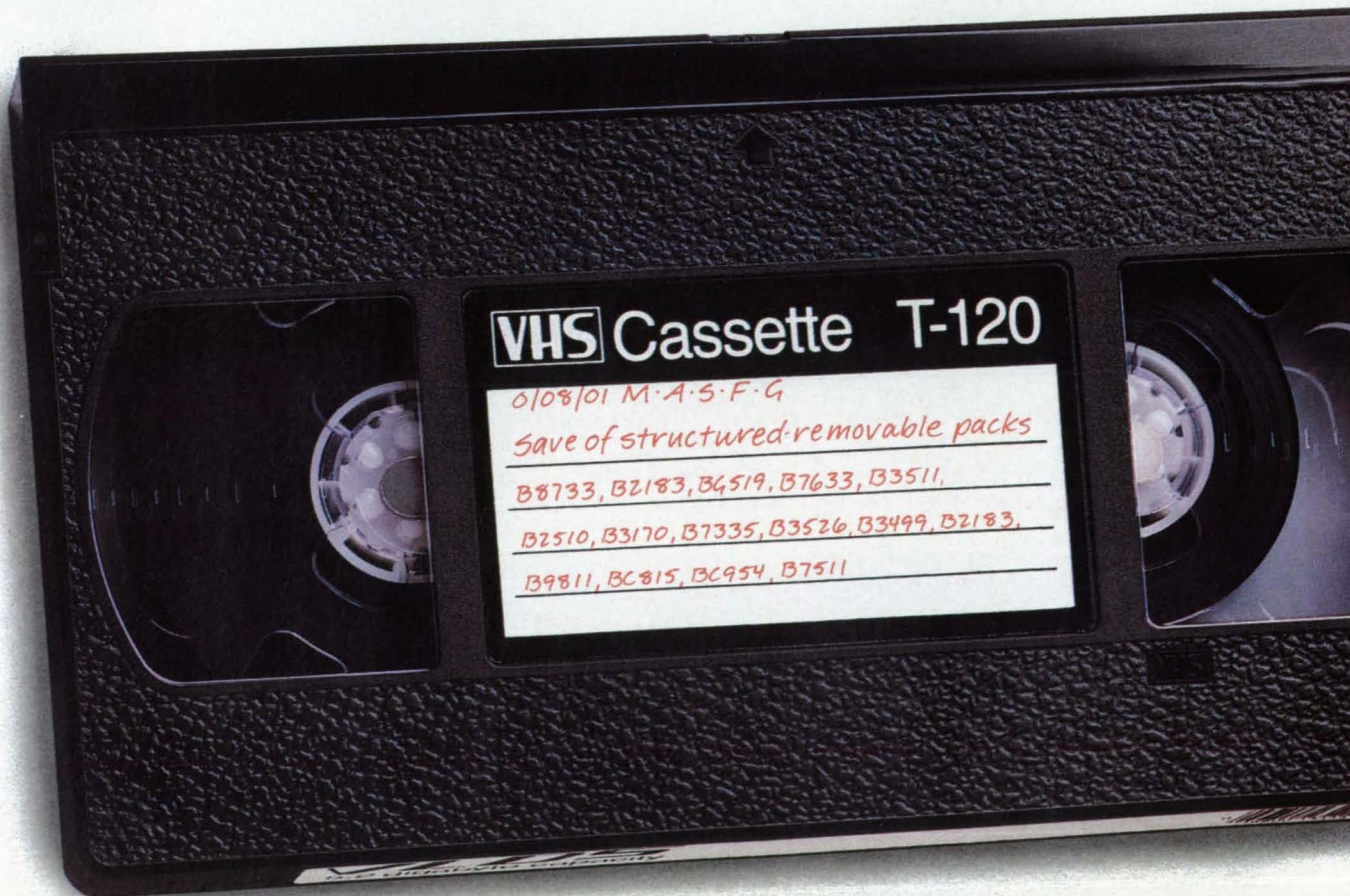

Laboratory. To obtain a copy of the report, "Performance of a Dedicated VLBI system for TDRSS Navigation," Circle 106 on the TSP Request Card. NPO-16319

Design Considerations for High-Speed Control Systems

Existing hardware can be integrated into a versatile, high-speed control system.

A report discusses five global design considerations to integrate array-processor, multimicroprocessor, and host-computer system architectures into versatile, high-speed controllers. Such controllers are capable of control throughputs as high as 36 MHz for 8-bit bytes and can maintain constant interaction with the non-real-time or user environment. As an application example, the architecture of a high-speed, closed-loop controller used to control helicopter vibration actively is briefly discussed.

Most modern computer-based control systems are represented by a rather straightforward integration of a central (host) computer with several unintelligent (i.e., nonprogrammable) peripheral devices. The host computer must supervise all actions of the peripheral devices and

synchronize the operations of each one with the rest of the system. Therefore, it is usually sufficiently burdened that it cannot support heavy input/output or extensive interaction with the user and maintain control of the system at the same time. In applications where simultaneous high control throughput and numerical computations are required, a point is reached where the necessary control computations cannot be done if the data input/output operation frequency is too high.

These difficulties can be avoided through the following five system-hardware design modifications:

1. Array processors can be added to mini-computer-based control systems to increase system performance by freeing the host from intensive numerical calculations. This leaves the host computer free to coordinate more input/output transfer and to sequence events.
2. The array processor can be used to separate the non-real-time events from the real-time events. This decoupling allows the array-processor-based loop-processor subsystem to process data at extremely high rates, while the executive subsystem monitors the user or non-real-time environment.
3. Large executive computers can enhance control system performance by

providing multitasking and multiuser environments necessary to synthesize flexible and versatile control systems.

4. The use of intelligent peripherals to share the real-time burden can increase system throughput by freeing the array processor from having to supervise the external devices.
5. Intelligent interfaces can provide high-speed data paths to maximize the speeds of communication and data transfer between the array processor and its external devices.

Unlike conventional control-system design, these design considerations are not aimed at optimally sizing the control-system components to fit a particular task. Rather they emphasize high throughput and flexibility.

This work was done by Stephen A. Jacklin, Jane A. Leyland, and William Warmbrodt of **Ames Research Center**. To obtain a copy of the report, "High-Speed, Automatic Controller Design Considerations for Integrating Array Processor Multi-Microprocessor, and Host Computer System Architectures," Circle 102 on the TSP Request Card.

Inquiries concerning rights for the commercial use of this invention should be addressed to the Patent Counsel, Ames Research Center [see page 19]. Refer to ARC-11670.

In the world of information storage, this is known as a warehouse.

Imagine storing up to 5.2 gigabytes of data on a standard T 120 VHS high-energy cassette. Now you can with Honeywell's new VLDS system (Very Large Data Store).



You no longer need thirty 10-inch reels of 6250 bpi 9-track computer tape. Or 5,200 double-sided 5¼-inch floppy disks. Or fifty-two 5¼-inch WORM optical disks. Just VLDS and a single standard VHS cassette.

VLDS provides a 4-megabyte-per-second sustained transfer rate, a media cost of less than .21¢ per megabyte, and a bit error rate of 10^{-12} . And to assure easier, cost-effective system integration, optional high-performance imbedded controllers are available, including SCSI and VAX/VMS.

VLDS is the latest advancement in Honeywell's line of magnetic tape systems that have been unsurpassed in quality and support services for over 30 years.

For details on VLDS, and its OEM pricing, contact Tom Balue, Honeywell Test Instruments Division, Box 5227, Denver, CO 80217-5227. (303) 773-4491.

Together, we can find the answers.

Honeywell

Physical Sciences

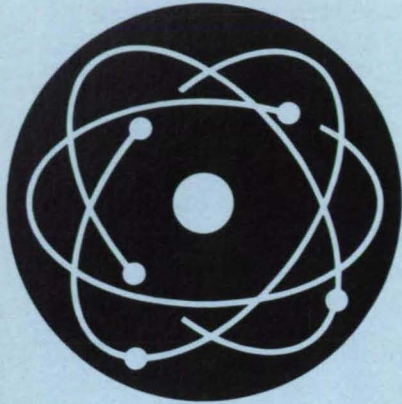

Hardware, Techniques, and Processes

- 30 Water-Cooled Optical Thermometer
- 31 Field-Reversal Source for Negative Halogen Ions
- 32 Measuring Shapes of Acoustically Levitated Drops

Books & Reports

- 32 Containerless Atomic-Fluorescence Property Measurements
- 33 Producing Hydrogen With Sunlight

Computer Programs

- 40 Designing Echelle Spectographs

Water-Cooled Optical Thermometer

High temperatures are measured without contact.

NASA's Jet Propulsion Laboratory, Pasadena, California

A water-cooled optical probe measures the temperature of a nearby radiating object. It is intended primarily for use in a silicon-growing furnace for measur-

ing and controlling the temperatures of the silicon ribbon, meniscus, cartridge surfaces, heaters, or other parts.

The sensing element (see figure) is a

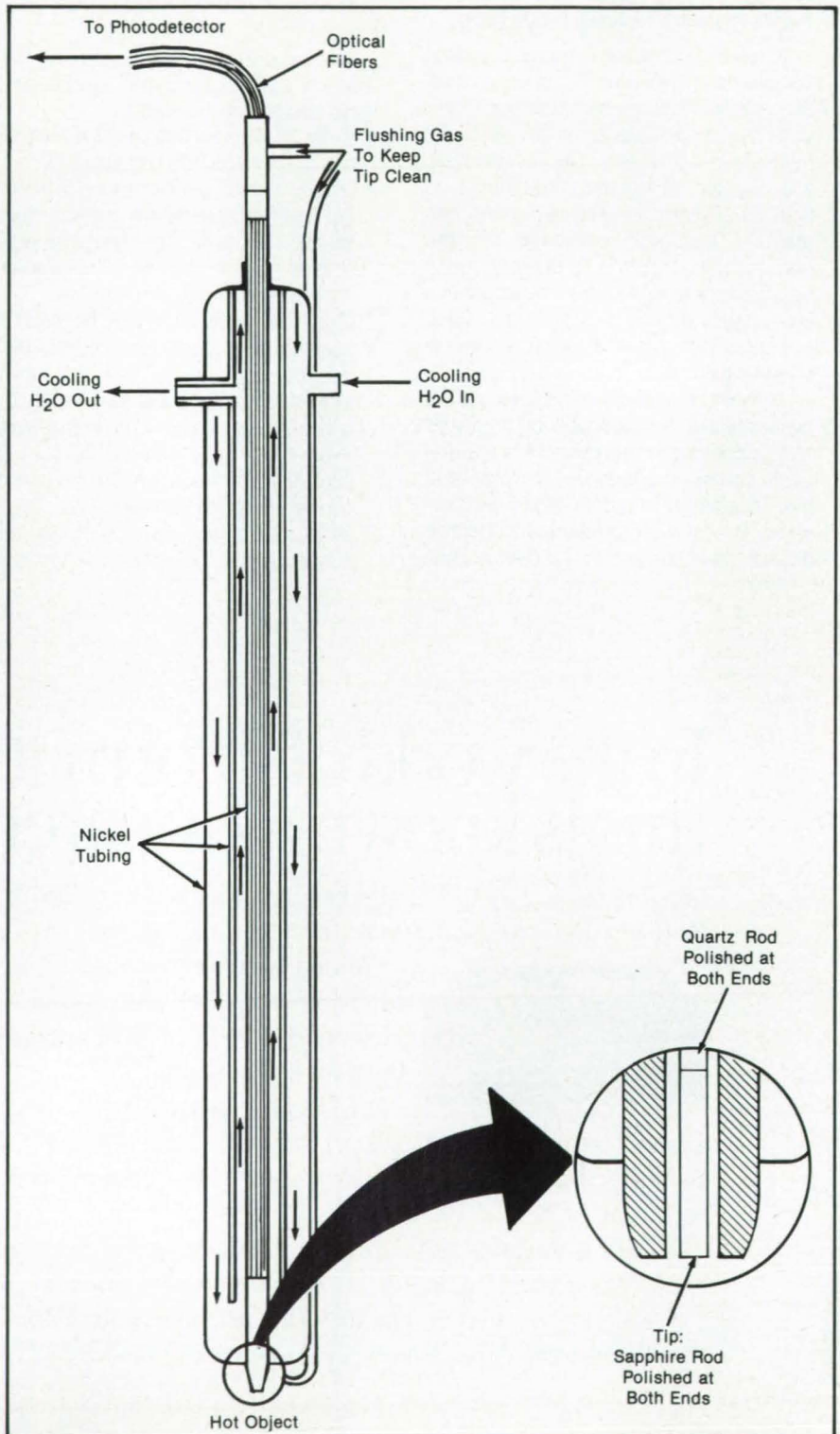

Cooling Water and Flushing Gas cool the fiber-optic probe and keep it clean. The fiber passes thermal radiation from the observed surface to a measuring instrument.

sapphire tip of 0.040 in. (1.0 mm) diameter, which passes the radiation to a quartz rod of the same diameter. The radiation travels along the rod into a bundle of optical fibers that conduct it to a photodetector circuit for measurement.

A flushing gas keeps the probe tip clean. This is important in the reactive environment of a crystal-growing furnace. The flushing gas can be fed through a quartz or nickel tube surrounding the

quartz rod and sensor tip. Alternatively or in addition, the gas can be fed to the tip through a narrow tube on the outside of the probe body.

The probe should not be used where the thermal mass of the body under observation is relatively small. This is because the cooling water and flushing gas remove heat from the observed surface. Preliminary experiments have shown that the probe should be placed at

least 2 mm from this surface to reduce unwanted cooling. In view of this perturbing effect, the suitability of the probe must be evaluated for each application.

This work was done by Andrew A. Menna of Mobil Solar Energy Corp. for NASA's Jet Propulsion Laboratory. For further information, Circle 129 on the TSP Request Card. NPO-16492

Field-Reversal Source for Negative Halogen Ions

Large zero-energy electron-attachment cross sections would result in intense ion beams.

NASA's Jet Propulsion Laboratory, Pasadena, California

A concept for producing negative halogen ions takes advantage of the large cross sections at zero kinetic energy for the dissociative attachment of electrons to such halogen-containing gases as SF_6 , CFCl_3 , and CCl_4 . Recent measurements of such cross sections show them to be much larger than previously expected. For example, the cross section for Cl^- production from CFCl_3 at zero electron kinetic energy is $7.57 \times 10^{-14} \text{ cm}^2$, which is many orders of magnitude higher than that for H^- production from H_2 at higher electron energies. The large cross sections are due to the divergent nature of the s-wave electron attachment cross section.

In the ion source (see figure), a beam of electrons is injected into a chamber containing a beam of the target gas. As the beam passes through the gas, a negative voltage pulse is applied to a grid to produce a momentary electric field that reverses the direction of motion of the electrons before they reach the grid.

At the turning point, the electrons have essentially zero kinetic energy with respect to the gas molecules and tend to be captured by them, forming negative halogen ions as the molecules dissociate. Transverse electrostatic fields are used to extract and focus the resulting ions (but not the electrons) into a beam.

The incident electron beam may be confined electrostatically or magnetically. Standard electron guns and ion-extraction systems can be used. Such parameters as the electron-beam energy and divergence, gas pressure, size of the reversal region, pulse voltage, pulse duration, and ion-drawout voltages should be optimized experimentally. If necessary, a small permanent magnet may be placed outside the extraction aperture to serve as a momentum filter to remove electrons from the ion beam.

It should also be possible to extend the use of this source to the generation of negative ions through attachment res-

onances located at nonzero energies, since a continuous distribution of electron energies exists as the electrons are slowed down. A description of this work appears in the *Review of Scientific Instruments*, Volume 56, page 69 (1985).
This work was done by Ara Chutjian, Otto J. Orient, and Samuel H. Aladzhadzhyan

of Caltech for NASA's Jet Propulsion Laboratory. For further information, Circle 150 on the TSP Request Card.

Inquiries concerning rights for the commercial use of this invention should be addressed to the Patent Counsel, NASA Resident Office-JPL [see page 19]. Refer to NPO-16247.

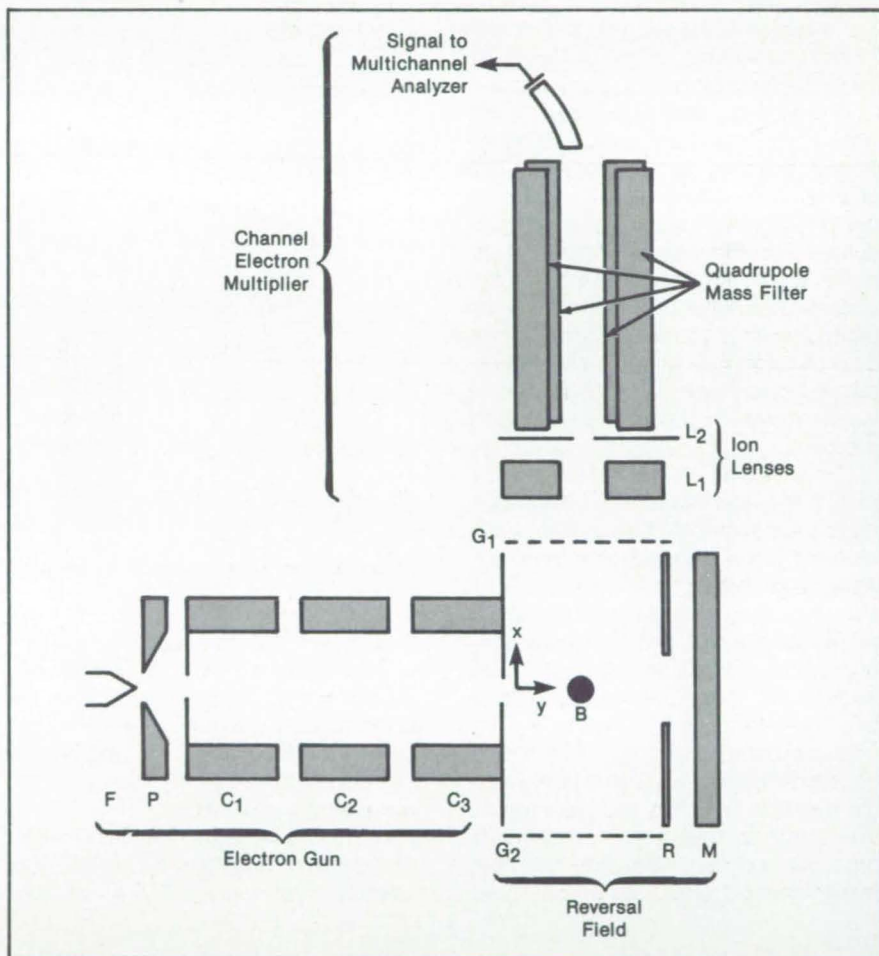

Schematic Diagram of the Apparatus shows the electron gun (F, P, C₁, C₂, C₃), the reversal electrodes (C₃, R, M) and extraction grids (G₁, G₂). The target molecular beam (B) is directed normal to the diagram. Ions are accelerated by lenses formed by L₁ and L₂ to a quadrupole mass spectrometer, counted, and the signal stored in a multichannel analyzer as a function of incident electron energy E_0 or potentials V_R, V_M .

onances located at nonzero energies, since a continuous distribution of electron energies exists as the electrons are slowed down. A description of this work appears in the *Review of Scientific Instruments*, Volume 56, page 69 (1985).

This work was done by Ara Chutjian, Otto J. Orient, and Samuel H. Aladzhadzhyan

of Caltech for NASA's Jet Propulsion Laboratory. For further information, Circle 150 on the TSP Request Card.

Inquiries concerning rights for the commercial use of this invention should be addressed to the Patent Counsel, NASA Resident Office-JPL [see page 19]. Refer to NPO-16247.



Measuring Shapes of Acoustically Levitated Drops

An instrument records shadows of drops in an acoustic field.

NASA's Jet Propulsion Laboratory, Pasadena, California

The shapes of acoustically levitated liquid drops and gas bubbles can be examined by a shadow projector. Although acoustic radiation pressure counterbalances the gravitational force acting on levitated drops and bubbles, the pressure usually is not uniform over their surfaces and causes them to assume nonspherical shapes. The shape of the drop or bubble gives useful information about the acoustic field and the levitated material. For example, if the acoustic field is well known, the surface tension of a drop can be determined from its size and shape.

A vibrating lower plate (see figure) driven by a transducer at 20 kHz generates a standing acoustic wave in the space between the lower plate and an upper plate that serves as an acoustic reflector. A collimated laser beam illuminates a sample drop levitated in this acoustic field. After passing the drop, the beam is enlarged, and the shadow of the drop, enlarged 20 times, is photographed. A microphone probe is moved to various points to measure the acoustic pressure.

Drops of such liquids as decane, octane, and water evaporate substantially during experiments. These liquids are levitated at constant acoustic pressure. As a drop shrinks, the surface tension becomes more dominant than the acoustic radiation stress, and the aspect ratio of the projected shadow (the ratio of its width to height) approaches 1 as the drop becomes more nearly spherical.

On the other hand, drops of liquids like hexadecane and glycerine do not evaporate appreciably during the experiments. For these the acoustic pressure is gradually reduced. The drop becomes more spherical until the acoustic pres-

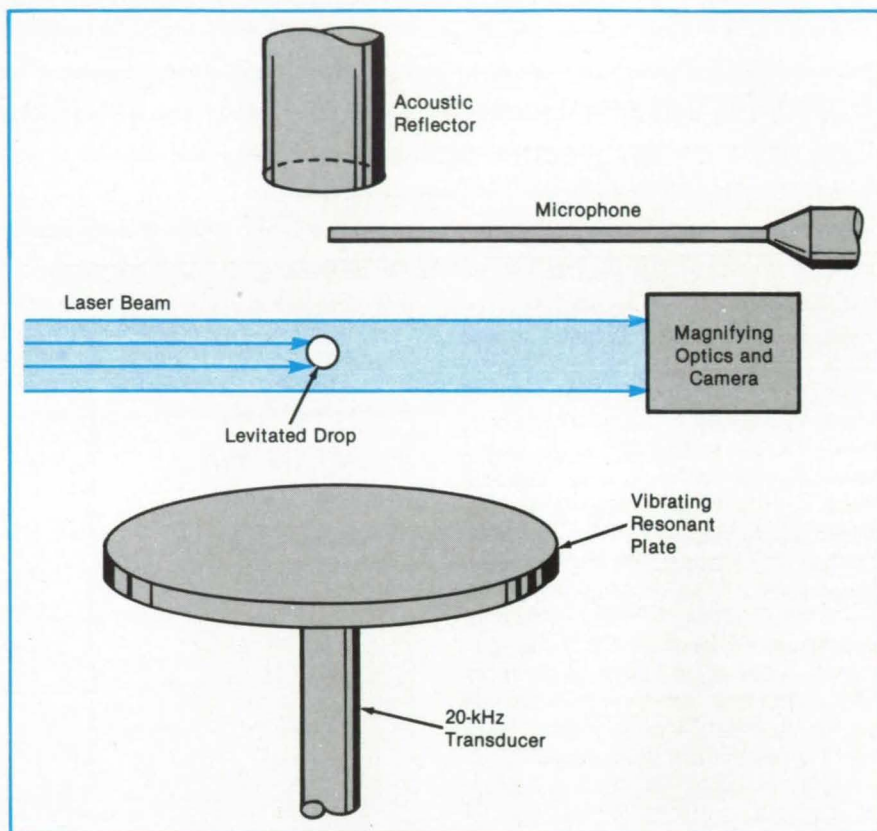

Held Aloft in a Laser Beam by an acoustic field, a liquid drop casts its shadow on photographic film. The changing shape of the drop is recorded in a sequence of exposures.

sure is too weak to support it.

Regardless of the volatility of the liquid, the film records of the aspect ratios can be compared with the values predicted by theory. In one set of experiments, drops were 1 mm or less in diameter. The surface tensions ranged from 20 to 70 dyn/cm, the acoustic pressure varied from 160 to 165 dB, and the aspect ratios were between 1 and 2. There was close

agreement between the theory and the measurements at aspect ratios less than 1.5 and drop sizes less than about 0.06 of the sound wavelength.

This work was done by Eugene H. Trinh and Chaur-Jian Hsu of Caltech for NASA's Jet Propulsion Laboratory. For further information, Circle 148 on the TSP Request Card. NPO-16746

Books and Reports

Containerless Atomic-Fluorescence Property Measurements

These reports, studies, and handbooks are available from NASA as Technical Support Packages (TSP's) when a Request Card number is cited; otherwise they are available from the National Technical Information Service.

Laser-induced fluorescence can be used to measure high-temperature processes.

A report describes studies conducted to establish and verify the use of laser-induced fluorescence in monitoring and controlling high-temperature container-

less processes. Specimens were levitated by gas jets or electromagnetic fields and heated by laser beams or electromagnetic induction while being irradiated and detected by the fluorescence technique. The reported work includes the development of an apparatus and its use in studies of the following phenomena:

- Chemical reactions on Al_2O_3 , Mo, W, and LaB_6 specimens;
- Methods for noncontact measurements of specimen temperature;
- Properties of levitating gas jets; and
- Radiative lifetimes and collisional

energy-transfer rates for electronically excited atoms.

A pulsed dye laser was used to induce fluorescence in atomic Hg, Al, Mo, W, La, and B. The Hg atoms were added to a jet of Ar. Al atoms were produced by the continuous-wave laser heating of aerodynamically levitated sapphire and polycrystalline alumina spheres or of self-supported sapphire filaments. Mo atoms were evaporated from solid spheres that were inductively levitated in a vacuum and heated by a laser. W atoms were evaporated from electrically heated filaments. La and B atoms were evaporated from an aerodynamically-levitated and laser-heated LaB₆ sphere.

The report makes quantitative and qualitative comparisons among three new methods of temperature measurement, all of which rely on laser-induced fluorescence. One method is gas-density thermometry with a seed gas (usually Hg). This method requires an inert ambient atmosphere. The other two methods involve measurements of the velocities of evaporating atoms or of the population ratios of different electronic states. These methods require the assumption that the gas is in thermal equilibrium with the hot surface of interest and provide a check on the assumption in that when the assumption is not correct, they yield equal temperatures only by coincidence.

The enthalpies of evaporation of W and Mo measured in these experiments agree, within experimental uncertainty, with the values in the literature. The evaluation of the LaB₆-evaporation results is complicated by theoretical difficulties in calculating radiative transitions of B atoms and the relationship between concentration and self-absorption of radiation. A further complication arises from the disagreement between earlier reported results and the results of these experiments. The discrepancies may be due in part to reactions with effusion cells.

The authors conclude that if accurate temperature measurements are taken, then containerless measurements of laser-induced fluorescence, coupled with calculations based on the third law of thermodynamics, can lead to the accurate determinations of reaction enthalpies. For binary compounds, the required data are the activities of the elemental components, which can be determined directly from the ratios of the intensities of laser-induced fluorescence over the material of interest to those over the pure elements at the same temperature. Gas-phase/condensed-phase equilibrium is required for such determinations, and approximate equilibrium would be achieved over high-temperature liquids. Equilibrium can be further assured by the use of an inert-gas atmosphere to retard evaporation.

This work was done by P. C. Nordine, R.

NASA Tech Briefs, March 1987

A. Schiffman, and C. A. Walker of Midwest Research Institute for Marshall Space Flight Center. Further information may be found in NASA CR-171038 [N84-25481/NSP], "Containerless High Temperature Property Measurements by Atomic Fluorescence."

Copies may be purchased [prepayment required] from the National Technical Information Service, Springfield, Virginia 22161, Telephone No. (703) 487-4650. Rush orders may be placed for an extra fee by calling (800) 336-4700. The report is also available on microfiche at no charge. To obtain a microfiche copy, Circle 65 on the TSP Request Card. MFS-27070

Producing Hydrogen With Sunlight

Costs would be high but could be reduced by further research.

Producing hydrogen fuel on a large scale from water by solar energy may be practical if plant costs can be reduced, according to a study. Sunlight is an attractive energy source because it is free and because its photon energy converts directly to chemical energy when it breaks water molecules into diatomic hydrogen and oxygen. The conversion process is low in efficiency, however, and a photochemical reactor must be spread over a large area, requiring a large investment in the plant.

The costs and performance of a photochemical plant that can produce 25,000 standard cubic meters per day of hydrogen have been studied. The flat-plate plant is estimated to have potential for achieving an overall plant efficiency of 10.3 percent with a predicted cost of the product between \$34 and \$55 per gigajoule of hydrogen energy. A potentially achievable overall efficiency for the concentrator system is judged to be 11.6 percent, and the predicted cost is \$94 to \$141 per gigajoule.

The overall plant efficiency is dominated by the relatively low efficiency of the photochemical process. The energy costs could be cut in half or more if the photochemical-energy-conversion efficiency could be doubled. The energy costs of the flat-plate system, for example, would then be in the range of \$19 to \$29 per gigajoule.

A solar quantum converter employing a single photochemical conversion system is unlikely to have an efficiency greater than about 15 percent. If multiple photochemical systems are used, higher efficiencies should be possible. The maximum thermo-

dynamic efficiency for a plant with two quantum-conversion systems could be as much as 50 percent greater than that of a plant with one photosystem.

The major cost component is the collector/reactor subsystem. This subsystem accounts for 37 percent of the total energy cost for the flat-plate plant and 64 percent for the plant using parabolic-trough collectors. Use of low-cost materials and construction methods in large collector/reactors should help to reduce energy costs. One promising idea of this type calls for a shallow pond with a thin photochemical layer as an inexpensive collector/reactor.

Field piping for distributing water to the reactors and removing hydrogen from them is not a large part of the cost. However, balance-of-plant costs encompassing the site preparation for the solar-powered plants, which have relatively large areas, account for a significant 44 percent of the energy cost for the flat-plate plant and 28 percent for the parabolic-trough plant. For a concentrating system, cooling is required to keep the reaction temperature low enough to yield sufficiently high photochemical efficiency. The need for cooling accounts for a modest 5 percent of the plant cost.

In general, high-temperature photochemical systems do not seem attractive because the thermodynamic efficiency decreases with increasing temperature. Similarly, hybrid photochemical/thermochemical systems do not seem economically viable: The low efficiency of the photochemical step would reduce the overall plant efficiency too much.

The economic analysis pertains to generic photochemical processes. It does not delve into details of photochemical reactor design because detailed reactor designs do not exist at this early stage of development. However, it is expected that reactor-design issues associated with product gas separation and unique materials problems will tend to increase energy costs. In this context, the analysis provides lower bounds on costs.

This work was done by John R. Biddle, Donald B. Peterson, and Toshio Fujita of Caltech for NASA's Jet Propulsion Laboratory. Further information may be found in NASA CR-173910 [N84-32917/NSP], "Solar Photochemical Process Engineering for Production of Fuels and Chemicals."

Copies may be purchased [prepayment required] from the National Technical Information Service, Springfield, Virginia 22161, Telephone No. (703) 487-4650. Rush orders may be placed for an extra fee by calling (800) 336-4700.

Inquiries concerning rights for the commercial use of this invention should be addressed to the Patent Counsel, NASA Resident Office-JPL [see page 19]. Refer to NPO-16728.

Materials

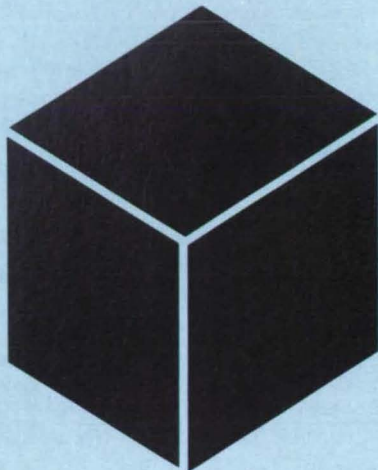

Hardware, Techniques, and Processes

- 34 New Polymeric Precursors of Silicon Carbide
- 34 Concept for Underground Disposal of Nuclear Waste
- 36 Electrically Conductive, Heat-Resistant Paint

Books and Reports

- 36 Long-Term Tests of 38 Ball-Bearing Greases
- 38 Amorphous-Metal-Film Diffusion Barriers
- 39 High-Temperature Thermoelectric Energy Conversion
- 39 Evaluation of Fiber-Reinforced Composites

New Polymeric Precursors of Silicon Carbide

Silicon carbide is made by pyrolyzing the polymers.

Lewis Research Center, Cleveland, Ohio

A method has been conceived for the preparation of poly(decamethylcyclohexasilanes) as precursors for the preparation of silicon carbide at a high yield. The technical potential of polysilanes as precursors of SiC ceramics is being explored. However, this potential is limited by the intractability of some polysilanes; the formation of small, cyclic polycarbosilane fragments during pyrolysis; and the overall low char yield and large shrinkage in conversion to ceramics.

The general objective of this work is to provide a novel polymer that has a high theoretical char yield and that can be used efficiently to make silicon carbide. To this end, a polymeric mixture of poly(decamethylcyclohexasilanes) of the type shown in the figure was prepared. When cross-linked, the polymer charred efficiently to give a 50-percent yield of silicon carbide. Presumably, the method can be improved, because the maximum theoretical char yield is 75 percent.

As an example, the 1,4-diphenyldecamethylcyclohexasilane polymer has been isolated and is being evaluated as a precursor of strong silicon carbide fibers. The polymer is also under study as matrix material for a ceramic-matrix composite. Because of the high char yield, the number of impregnations required to form a SiC matrix is reduced, reducing the processing time and cost in comparison with state-of-the-art materials.

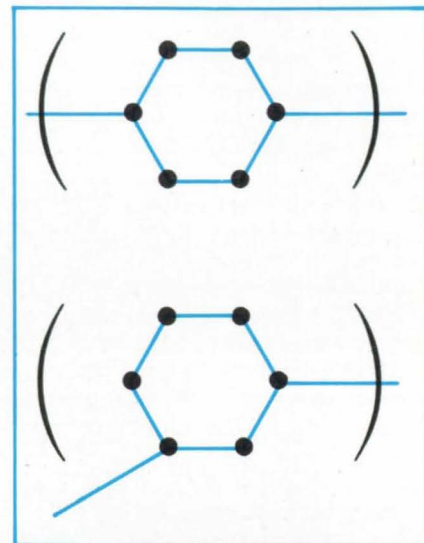

These **Poly(decamethylcyclohexasilanes)** can serve as precursors of silicon carbide. (Each dot represents a silicon atom with sufficient methyl groups attached to bring the total valency of silicon to four.)

This work was done by M. H. Litt and Kanta Kumar of Case Western University for Lewis Research Center. No further documentation is available.

Inquiries concerning rights for the commercial use of this invention should be addressed to the Patent Counsel, Lewis Research Center [see page 19]. Refer to LEW-14272.

Concept for Underground Disposal of Nuclear Waste

Packaged waste would be placed in empty oil-shale mines.

NASA's Jet Propulsion Laboratory, Pasadena, California

A concept for the disposal of nuclear waste would be economically synergistic with an earlier proposal concerning the backfilling of oil-shale mines. The new disposal concept may be superior to earlier schemes for disposal in hard-rock and salt mines because there is less uncertainty about the ability of the oil-shale mine to contain the waste safely for a millenium.

The mines in question are located in the Uintah Basin. Because the oil-shale formation there is shaped like a bowl, water percolating through the formation

will tend to accumulate in the center. Thus, the natural flow of water should not leach the waste materials into aquifers used by humans. Because there are no known exploitable mineral resources under the oil shale and because the shale itself will have been taken, it is correspondingly less likely that future generations will be tempted to penetrate the storage layer: this is an important advantage because over time surface signs can disappear, maps can be lost, and old warnings can be forgotten.

The oil-shale mines would be excavat-

THE CHALLENGE: "IMPROVE THE FATIGUE STRENGTH OF CAST AMS 4225 ALUMINUM CYLINDER HEADS." CAN IT BE DONE?

A pretty tall order. But one that our Thermatech Hot Isostatic Pressing facility handled easily. Every HIP'ed part we tested passed x-ray standards without a single reject and met FAA durability requirements for airworthiness. This customer, Avco Lycoming, has instituted HIP as bill of material for the AMS 4225 aluminum cylinder heads for all their reciprocating aircraft engines.

EXTENSIVE APPLICATIONS FOR HIP'ing.

HIP'ing subjects components to a high gas pressure and elevated temperature sufficient to close shrinkage porosity and internal voids. Many engineers are surprised to learn that HIP'ed cast components deliver the consistency expected of forgings with similar mechanical properties. And not just in titanium and superalloys. Performance improvements are also noted in steel, bronze, cast iron, ceramics and aluminum. Our Thermatech Division is licensed to HIP aluminum under the Alcoa patented 359 process. When there's a demand we can also HIP powder metal components.

HIP'ing lowers life cycle costs and not just for the aerospace industry. HIP'ing is also used for automotive pistons, rods, crankshafts and engine blocks. It even has applications for medical implants and pump impellers for the oil industry.

PIONEERS IN PRODUCTION HIP'ing IN THE U.S.

Our years of experience with metallurgy, materials systems and applications and investment casting convinced us that HIP'ing could provide breakthrough applications. We began production HIP'ing in 1975 and now we have one of the largest capacities in the United States with capabilities to 46½" diameters, pressures to 45,000 psi and temperatures to 4,000°F.

HIP'ing is one more service Howmet provides, enhancing our position as a fully integrated, high technology manufacturer.

THE IMPOSSIBLE MADE POSSIBLE.

One of the things that sets Howmet apart is our separate 65,000 square foot research, development and engineering center. Here metallurgical teams and laboratory specialists come up with breakthrough solutions to seemingly impossible challenges. They are always available to you as a Howmet customer.

WE INVITE YOUR CHALLENGES.

At Howmet, we will work closely with you, engineer to engineer, from concept through design to finished product. Whether your problem requires a simple but cost effective solution or state-of-the-art technology for complex applications, you'll find Howmet able to help.

For more information on HIP'ing and the potential this holds for you, write our Marketing Department, Howmet Turbine Components Corporation, 475 Steamboat Road, Greenwich, CT 06836-1960. Or phone the manager of the Thermatech HIP Department at (616) 894-5686.

IMPOSSIBLE? CHALLENGE US.

 **Howmet**

Thermatech Division, Whitehall, MI

Circle Reader Action No. 335



ed by the room-and-pillar technique. Portland cement would be manufactured in a plant at each mine, using locally available limestone or dolomite plus about 10 percent of the spent oil shale. The remainder of the spent shale would be mixed with the cement as aggregate, and the resulting concrete would be pumped into the mined passages. Once the concrete is cured to sufficient strength to support the overburden, the roof-supporting pillars and walls would be mined out, then similarly replaced by concrete.

In the disposal scheme, the packages of nuclear waste would be placed in the empty mine before pumping in the concrete backfill. If necessary, disposal pits

could be sunk into the hard-rock mine floor, with little hard-rock mining. At less expense, the disposal pits could be formed in the backfilling concrete. During the filling and storage stages, only the necessary inspection passages and ventilation shafts would be left unfilled. Like shafts and passages in concrete dams, these would occupy only a minor portion of the volume and would not threaten the structural integrity. After about 50 years of inspection and monitoring to assure security, the shafts and tunnels would be filled completely.

Although the long-term mechanical characteristics of cements are fairly well known, tests will still have to be done to

determine the hydrologic characteristics of spent-shale cements. However, because much is known about the hydrologic behavior of concrete dams, it should be possible to develop the corresponding information for spent-shale cements quickly and easily. Similarly, data regarding thermal effects on the integrity of concrete are available from the histories of concrete used in or near furnaces, retorts, and the like.

This work was done by James M. Bowyer of Caltech for NASA's Jet Propulsion Laboratory. For further information, Circle 10 on the TSP Request Card. NPO-16042

Electrically Conductive, Heat-Resistant Paint

A graphite/silicate paint for titanium substrates withstands vibration and thermal shock.

NASA's Jet Propulsion Laboratory, Pasadena, California

An improved, sprayable, thermal- and electrostatic-discharge-control coating for titanium possesses excellent adhesion and high resistance to both vibration and thermal shock. The coating is an improved formulation of the one described in "High-Temperature Coatings for Titanium" (NPO-16222) page 498, *NASA Tech Briefs*, Vol. 8, No. 4, (Summer 1984).

As originally formulated, the coating consists of a graphite pigment with a potassium silicate binder. In the cured state, the pigment-to-binder ratio is 1:1. In the wet-mixture state, the original coating material consists of 19 percent of graphite pigment (20- μ m average pigment-particle size), 53 percent of a 35-percent potassium silicate solution, and 28 percent distilled water. The pigment, binder, and water are processed in a jar mill for 3 hours. The contents of the

mill are then applied to the titanium surface, using a state-of-the-art spray gun at an air pressure of approximately 35 psi (241 kPa). A curing time of 24 hours is recommended.

The new coating liquid consists of 76.2 weight percent of the original formulation, 9.5 weight percent zinc oxide, and 14.3 weight percent WB-500 (or equivalent) carbon. After this mixture has been milled for about 1.5 hours, 10 to 20 grams of water are added to each 100 grams of mixture to reduce the viscosity to enable easy spraying.

The original coating failed certain tests at high temperatures, with possible evidence of vaporization of beaded water in the coating matrix and occasional blistering and loss of adhesion of the coating to the titanium substrate. In addition to meeting the thermo-optical and

electrical-conductivity requirements of the spacecraft application for which the new coating was devised, cured test samples suffered no observable effects when subjected to oven thermal shock at 70 to 400 °F (21 to 204 °C), 70 to 800 °F (21 to 427 °C), and to hot-plate thermal shock at about 70 to 500 °F (21 to 268 °C). No effects were noted with conventional thermal and water-immersion testing. Compared to plasma-spray-coated iron titanate on titanium foil, the original and modified coatings show similar emissivity and absorptivity but slightly higher surface electrical resistivity.

This work was done by Victor F. Hribar and Richard J. Mell of Caltech for NASA's Jet Propulsion Laboratory. For further information, Circle 41 on the TSP Request Card. NPO-16325

Books and Reports

These reports, studies, and handbooks are available from NASA as Technical Support Packages (TSP's) when a Request Card number is cited; otherwise they are available from the National Technical Information Service.

Long-Term Tests of 38 Ball-Bearing Greases

Perfluoroalkylpolyether lubricants performed best.

The final report in a series presents the results of a program of long-term testing of ball-bearing greases in vacuum, oxidizing, and otherwise hostile environments. The earlier reports in the same series were described in "Tests of 38 Ball-Bearing Greases," (MFS-25624), *NASA Tech Briefs*, Vol. 6, No. 3, page 330, and "Further Tests of 38 Ball-Bearing Greases," (MFS-27043), *NASA Tech Briefs*, Vol. 9, No. 1, page 111.

The greases were tested in ball bearings of electric motors that were subjected to a variety of operating conditions, including humid oxygen, vacuum at 38 °C, vacuum at 93.3 °C, vacuum at ambient temperature with start/stop operation, and low-

temperature start (various temperatures). The lubricants were evaluated qualitatively in terms of the occurrence or nonoccurrence of bearing failure and quantitatively in terms of bearing weight loss.

The findings remain essentially unchanged from the earlier reports: The class of lubricants based on perfluoroalkylpolyether (PFPE) continued to give the best results in vacuum operation in both 1-year and 5-year tests. In 5-year start/stop tests, one of the PFPE lubricants showed the lowest weight loss. Some silicone, mineral, and synthetic-ester lubricants also showed promise in 1-year vacuum ambient-temperature tests.

This work was done by E. L. McMurtrey

Our Thermal Barrier Protection

Maximizes Performance!



Ceramic Thermal Barrier Coatings
on Pistons

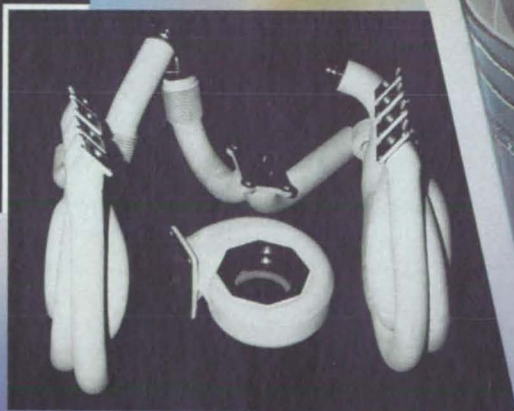

Ceramic Thermal Barrier Coatings
on Header/Turbo System



At APS-Materials, we provide the latest in arc-plasma technologies for your designs...coatings for tribology, thermal barrier and hot corrosion applications. We offer you advanced solutions, engineered by our qualified experts. And in addition to your coating needs, we can help you with R&D, production and job shop services.

APS MATERIALS, INC. THE METAL & CERAMIC COATING SPECIALISTS



For further enquiries contact one of our sales representatives.

153 Walbrook Ave.
Dayton, Ohio 45405
(513) 278-6547

101 Trade Center Pkwy.
Conroe, TX 77385
(409) 273-1174

Circle Reader Action No. 489

of Marshall Space Flight Center. Further information may be found in NASA TM-86480 [N85-11239/NSP], "An Evaluation of Grease-Type Ball Bearing Lubricants Operating in Various Environments (Final Status Report No. 8)."

Copies may be purchased [prepayment required] from the National Technical Information Service, Springfield, Virginia 22161, Telephone No. (703) 487-4650. Rush orders may be placed for an extra fee by calling (800) 336-4700. The report is also available on microfiche at no charge. To obtain a microfiche copy, Circle 89 on the TSP Request Card.
MFS-27089

Amorphous-Metal-Film Diffusion Barriers

Incorporation of N into Ni/W films reduces their reactivity with Si substrate.

A paper describes the reactions between Si substrates and deposited amorphous Ni/W or Ni/N/W films. The thermal stability of amorphous Ni/W films as diffu-

sion barriers in Si is markedly improved by the introduction of N into the Ni/W films during deposition.

Amorphous films on Ni/W and Ni/N/W were deposited on single-crystal silicon with discharge gases of Ar or Ar + N₂ by radio-frequency cosputtering of Ni and W. The reaction of these Ni/W and Ni/N/W films with the Si substrates were studied in the temperature range of 450 to 750 °C by a combination of backscattering spectrometry, X-ray diffraction, cross-sectional-transmission electron microscopy (XTEM), and measurements of electrical resistivity.

The results have shown films with composition Ni₃₆W₆₄ to be stable below 500 °C. Both NiSi and NiSi₂ form at 500 °C and WSi₂ forms rapidly in the temperature range of 625 to 650 °C. The nickel silicide forms adjacent to and within the Si, while the outer layer becomes a mixture of WSi₂ and NiSi₂. The crystallization temperature of amorphous Ni₃₆W₆₄ films on SiO₂ is also near 650 °C.

Adding nitrogen to form amorphous Ni₃₀N₂₁W₄₉ films lowers the crystallization temperature but raises the reaction temperature with Si to 750 °C. (Interestingly, X-ray diffraction shows that the amorphous Ni₃₀N₂₁W₄₉ film crystallizes before it reacts with the Si substrate.) The reduced reactivity of Ni in

the nitrogen-containing film is unlikely to be the result of the binding of Ni by N, since Ni does not form stable nitrides at these elevated temperatures. Rather, the enhanced stability may be the result of a kinetic barrier formed by the stable W₂N. Detailed XTEM studies are needed to answer this question.

This research is important because it is desirable to reduce the diffusion of electrical-contact materials into silicon electronic devices. Thus, the reduced reactivity of amorphous films is noteworthy. Possible ways to suppress or circumvent the undesirable local reactions below the crystallization temperature include the following:

- Replacement of Ni by an element with a higher silicide formation temperature;
- Use of buffer layer (e.g., NiSi) between the amorphous film and the Si substrate;
- Use of ternary amorphous films (e.g., Ni/N/W); or
- Use of multilayered amorphous films. In view of the practical interest, these possibilities may soon be tested.

This work was done by Marc A. Nicolet of Caltech for NASA's Jet Propulsion Laboratory. To obtain a copy of the report, "Reaction of Amorphous Ni-W and Ni-N-W films with Substrate Silicon," Circle 9 on the TSP Request Card.
NPO-16637

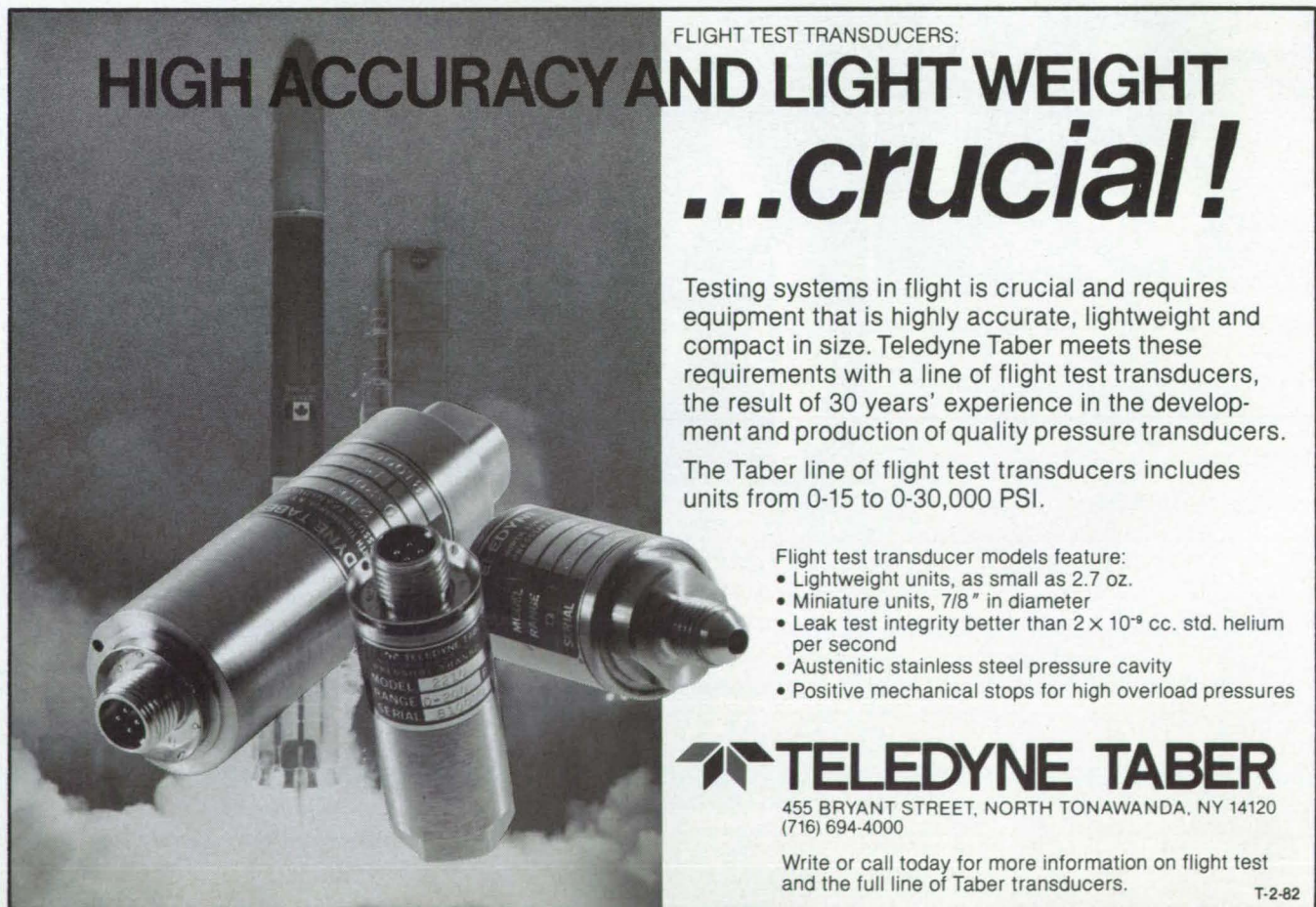

FLIGHT TEST TRANSDUCERS:

HIGH ACCURACY AND LIGHT WEIGHT ...crucial!

Testing systems in flight is crucial and requires equipment that is highly accurate, lightweight and compact in size. Teledyne Taber meets these requirements with a line of flight test transducers, the result of 30 years' experience in the development and production of quality pressure transducers.

The Taber line of flight test transducers includes units from 0-15 to 0-30,000 PSI.

Flight test transducer models feature:

- Lightweight units, as small as 2.7 oz.
- Miniature units, 7/8" in diameter
- Leak test integrity better than 2×10^{-9} cc. std. helium per second
- Austenitic stainless steel pressure cavity
- Positive mechanical stops for high overload pressures

TELEDYNE TABER
455 BRYANT STREET, NORTH TONAWANDA, NY 14120
(716) 694-4000

Write or call today for more information on flight test and the full line of Taber transducers.

T-2-82

High-Temperature Thermoelectric Energy Conversion

Semiconductor materials are the best choice.

The theory of thermoelectric energy conversion at high temperatures and the status of research on conversion materials are reviewed in a report. The report shows that the highest values of the thermoelectric figure of merit, Z , are found in semiconductor materials. Besides offering high Z , semiconductors have the advantage of being available in a wide choice of elements and compounds. Moreover, their electrical properties can be tailored to a particular application by impurity doping and control of stoichiometry.

The report develops a definition of Z that is useful for comparing materials and uses it to evaluate the potentials of different classes of materials—metals, semiconductors, and insulators. It explores the conditions for optimizing both broadband and narrowband semiconductors. For broadband materials, the highest Z values are in materials with high charge-carrier mobilities and large charge-carrier effective masses. For narrowband semiconductors, the requirements are for high lattice vibrational frequencies, large hopping distances, and hopping sites that are distributed in energy so as to allow the significant transport of vibrational energy.

The report notes that there is no theoretical basis for the widely held belief that a value of about 1 is the upper limit for ZT , the product of the figure of merit and the absolute temperature. In fact, the report suggests that ZT values considerably greater than 1 can be achieved at high temperatures. Z is not likely to be reduced significantly by radiation transfer at temperatures lower than 2,000 K.

Two groups of materials are especially promising for high Z : the rare-earth chalcogenides and the boron-rich borides. The report explains the electronic-transport properties of the rare-earth chalcogenides by regarding them as degenerate or partially degenerate n-type semiconductors. It proposes detailed explanations of the p-type hopping conductivity of boron-rich borides according to the particular compound.

This work was done by Charles Wood of Caltech for NASA's Jet Propulsion Laboratory. To obtain a copy of the report, "High Temperature Thermoelectric Energy Conversion Theory and Materials," Circle 128 on the TSP Request Card. NPO-16548

Evaluation of Fiber-Reinforced Composites

The mechanical properties of a graphite/epoxy material are determined.

A report describes procedures for evaluating properties of advanced fiber-reinforced composite materials. The procedures include quality control, fabrication techniques, specimen machining, test methods, and data collection and interpretation. The procedures were applied to a specific material: Thornel P-100 carbon fiber combined with Fiberite 934 epoxy resin in the form of unidirectional tape.

Special emphasis is given to quality control during the preparation of samples. Tests on the prepreg material, including measurements of gel time, resin solids content, tack, volatile content, and flow, are detailed. The steps of the fabrication and machining processes are described.

Both destructive and nondestructive techniques were used to assess the properties of the cured laminates. Mechanical tests were performed to measure the tensile strength and modulus, compressive strength and modulus, interlaminar and inplane shear strength, and flexural strength and modulus.

The results are compared with data generated by the manufacturer. The agreement between the two sets of data is good for the fiber-dominated properties. But because two different resins were used, comparisons of matrix-dominated properties would not be meaningful. However, other evidence indicates that the results for the matrix dominated properties are reasonable.

This work was done by Raymond G. Clinton, Jr., of Georgia Institute of Technology for Marshall Space Flight Center. To obtain a copy of the report, "Mechanical Property Characterization of P-100/934 Graphite-Epoxy Composite Material," Circle 28 on the TSP Request Card. MFS-27149

AmAlox 68

High Density Alumina Ceramic

- Mechanical stability to near 3000°F.
- High resistance to corrosion and oxidation
- Extreme wear resistance
- Hardness is 91.5 Rockwell A
- Compressive strength is 400,000-450,000 psi
- Part tolerance can be held to 0.0001 inch
- Out performs conventional and electronic grade ceramics in wear applications 5 to 10 times
- Precision and complex parts manufactured to your specifications in prototype to production quantities
- Applications include: piston caps/rings; exhaust port/manifold/cylinder liners; blades, vanes, shrouds, rotors, water pump seals, and valve train components



am



Astro Met Associates, Inc.

9974 SPRINGFIELD PIKE
CINCINNATI, OHIO 45215
513-772-1242
Telex (23) 29-5526

Circle Reader Action No. 484

UNI SLIDE[®] Linear Slides

for Instruments & Machines

VERSATILE • COMPACT • ECONOMICAL

TYPICAL 3 WAY MOTION X-Y-Z

SCREW DRIVEN

IN STOCK

Slides for Precision Applications

Series	Cross Section
Series B9000	9" w x 3 1/8" h
Series A6000	6" w x 1 3/4" h
Series A4000	4" w x 1 1/8" h
Series A2500	2 1/2" w x 1 3/16" h
Series A1500	1 1/2" w x 3/8" h

Lengths to 90". Loads to 400 lbs.



MANUAL UNISLIDE ASSEMBLIES

With or without lead screws • Way covers
Micrometer Screw Models • Rotary Tables
Rapid Advance with Lock and Fine Screw Motion
English & Metric Scales and Verniers • Turntables



LINEAR UNISLIDE CONSTRUCTION: 2024-T4 Aluminum Dovetail Base, Sliding Element with Laminated Nylatron GS Bearing Pads.

Custom Modifications to your Specifications

REQUEST GENERAL CATALOG

VELMEX, INC.

P.O. BOX 38
E. BLOOMFIELD, NJ 14443
Telephone 716/657-6151
Fax 716/657-6153

Circle Reader Action No. 447

Computer Programs



- 40 Designing Echelle Spectrographs
- 42 Thermal-Analysis Program
- 42 Buckling Analysis of Rectangular Plates with Holes
- 42 Analysis of Scramjet Inlets
- 42 Solving Ordinary Differential Equations

COSMIC: Transferring NASA Software

COSMIC, NASA's Computer Software Management and Information Center, is the one central office established to distribute software that is developed with NASA funding. COSMIC's role as part of NASA's Technology Utilization Network is to ensure that NASA's advanced software technology is made available to industry, other government agencies, and academic institutions.

Because NASA's software development efforts are dynamic and ongoing, new programs and updates to programs are added to COSMIC's inventory on a regular basis. *Tech Briefs* will continue to report information on new programs. In addition, the 1987 edition of the *COSMIC Software Catalog* is available with descriptions and ordering information for available software. Several new programs for control systems/robotics, expert systems, thermal analysis, turbomachinery design, structural analysis, and computer graphics are offered.

For additional information on any programs described in this issue of *Tech Briefs*, circle the appropriate number on the TSP card at the back of the publication. If you don't find a program in this issue that meets your needs, you can call COSMIC directly at (404) 542-3265 and request a review of programs in your area of interest. There is no charge for this information review.

COSMIC®

Computer Services Annex, University of Georgia, Athens, GA 30602; Phone (404) 542-3265
John A. Gibson, Director

Computer Programs

These programs may be obtained at a very reasonable cost from COSMIC, a facility sponsored by NASA to provide tested and reliable software to the public. For information on program price, size and availability, circle the reference number on the TSP and COSMIC Request Card in this issue.



Physical Sciences

Designing Echelle Spectrographs

Performance numbers and output maps are computed from inputs supplied by the user.

Echelle Spectrograph Design Aid program (EGRAM) aids in the design of spectrographic systems that utilize echelle/first-order cross-disperser combinations. This optical combination causes a two-dimensional echellogram to fall on a detector. EGRAM describes the echellogram with enough detail to enable the user to judge effectively the feasibility of the spectro-

graph design. By iteratively altering system parameters, the desired echellogram can be achieved without making a physical model. EGRAM calculates system parameters that are accurate to the first order and compare favorably to results from ray-tracing techniques.

The spectrographic system modeled by EGRAM consists of an entrance aperture, collimator, echelle, cross-dispersion grating, focusing optics, and a detector. The system is assumed to be free of aberrations, and the echelle, cross disperser, and detector should be planar. The EGRAM program is menu driven and has a HELP facility.

The user is prompted for such information as minimum and maximum wavelengths, slit dimensions, ruling frequencies, detector geometry, and angle of incidence. EGRAM calculates the resolving power and range of order numbers covered by the echellogram. A numerical map is also produced. This tabulates the order number, slit bandpass, and high/middle/low wavelengths. EGRAM can also compute the centroid coordinates of a specific wavelength and order (or vice versa).

EGRAM is written for interactive execution and is available in two versions. The first version is written in FORTRAN 77 and has been implemented on a DEC VAX-series computer operating under VMS. The second version is written in Microsoft BASIC A and has been implemented on an IBM PC-series computer operating under DOS. EGRAM was developed in 1985.

This program was written by Andrew Dantzier of Goddard Space Flight Center. For further information, Circle 46 on the TSP Request Card. GSC-13009

How to stop water vapor from destroying your vacuum system when you're plasma etching.

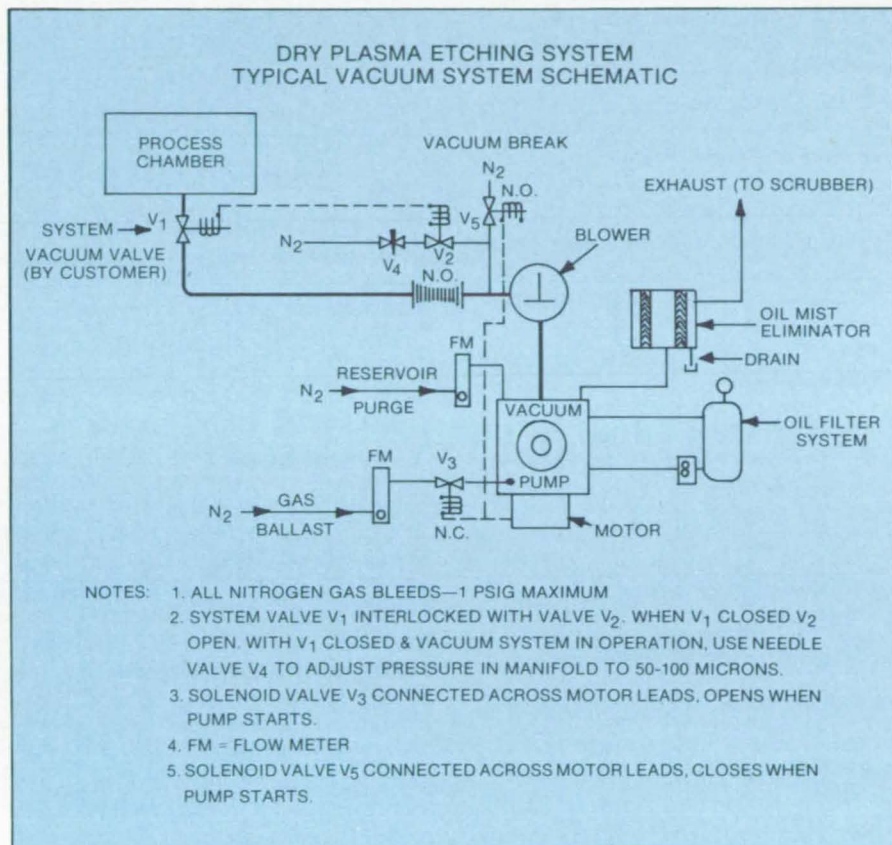

Due to the corrosive nature of the gases used and the particulates generated, plasma etching can impose harsh requirements on your vacuum system.

The presence of water vapor makes these conditions even more severe.

To keep your vacuum system performing to its capabilities, you must prevent water vapor from entering the system. If it does, you must remove it quickly.

The following installation and operation procedures will help you keep your system operating smoothly.

The right installation.

Install PVC exhaust piping instead of galvanized or black iron pipe, and an oil mist eliminator to reduce oil loss from the pump.

The exhaust line should be installed so it can easily be disassembled for

periodic cleaning and the vacuum manifold must be leak-free.

The right operation.

Operate the vacuum system continuously and make sure the vacuum pump is gas ballasted during processing with a nitrogen flow rate of 1 to 2 L/M.

Purge the reservoir with nitrogen (in humid ambients it may be necessary to increase the nitrogen flow). Do not pump on the process chamber with the vacuum system at blank-off pressure as oil backstreaming may result. When necessary to shut down the vacuum system for over 8 hours, fill gas ballast with nitrogen for at least 4 hours before stopping.

The right maintenance.

Drain the exhaust oil mist eliminator weekly. If oil is clean, it can be reused by

returning to the pump. If it is "milky" or cloudy, it should be decanted before returning to pump reservoir. Cleaning interval is determined by the amounts of particulates accumulated.

Monitor differential pressure across the oil filter. Replace element when filter pressure shows a significant increase above baseline pressure. Actual pressures will be determined by your own process.

Open pump reservoir at 2-month intervals to remove sediment from bottom of the reservoir. And when the particulate oil filter elements are used, replace element when filter pressure as shown on the gage is exceeded.

The right vacuum system.

Stokes is America's full-line vacuum components manufacturer so we have the right pumping package for your application. So you don't have to over-design or over-purchase.

If you have a processing design question call or write: Stokes Division, Pennwalt Corporation, 5500 Tabor Road, Philadelphia, PA 19120. 215-831-5400.

Send for free
subscription to
Vac-Tech News.

Keep up with the latest developments and advanced technology taking place in the vacuum industry. Just call or write and we'll see that you receive each issue.



STOKES
PENWALT
EQUIPMENT ■ CHEMICALS
HEALTH PRODUCTS

Stokes Division, Pennwalt Corporation
5500 Tabor Road, Philadelphia, PA 19120
Phone: 215-831-5400



Thermal-Analysis Program

Temperature changes with time are modeled with the traditional electrical analog.

The General Thermal Analyzer program solves transient and steady-state thermal problems using desk-top computers. The user models the thermal problem in terms of a resistance and capacitance network. The user defines the network, writes his own variable block, and has available most of the options associated with thermal-analyzer programs written for mainframe computers. Relax-network provisions for zero-capacitance nodes, one-way conductors for the simulation of fluid flow, and bivariate-data interpolation are some of the features included. The program currently handles up to 400 nodes. More nodes can be added if the program arrays are re-dimensioned, and the maximum number is limited only by the available memory.

This program is written in BASIC for interactive execution and has been implemented on two microcomputers. The General Thermal Analyzer was developed on an HP 9845 computer in 1982. In 1985, the program was adapted to an IBM PC operating under DOS.

This program was written by Don I. Levine of Rockwell International Corp. for Johnson Space Center. For further information, Circle 4 on the TSP Request Card. MSC-21140

Buckling Analysis of Rectangular Plates With Holes

Loads and deflections are predicted for a variety of cutouts.

BUCKO is a computer program developed to predict the buckling of a rectangular compression-loaded orthotropic plate with a centrally located cutout. The plate is assumed to be a balanced, symmetric laminate of uniform thickness. The cutout shape can be elliptical, circular, rectangular, or square. The BUCKO package includes sample data that demonstrate the essence of the program and its ease of use.

BUCKO uses an approximate one-dimensional formulation of the classical two-dimensional buckling problem following the Kantorovich method. The boundary conditions are considered to be simply supported unloaded edges and either

clamped or simply supported loaded edges. The plate is loaded in uniaxial compression by either uniformly displacing or uniformly stressing two opposite edges of the plate.

The BUCKO analysis consists of two parts: the calculation of the stress distribution in the plane prior to buckling, and the calculation of the plate axial load and displacement at buckling. The user input includes the size and shape of the plate planform and cutout, the plate membrane and bending stiffnesses, finite-difference parameters, boundary-condition data, and loading data. The results generated by BUCKO are the pre-buckling strain energy, in-plane stress resultants, buckling-mode shape, critical end shortening, and average axial and transverse strains at buckling.

BUCKO is written in FORTRAN V for batch execution and has been implemented on a CDC CYBER 170-series computer operating under NOS with a central-memory requirement of approximately 343K of 60-bit words. This program was developed in 1984.

This program was written by Michael P. Nemeth of Langley Research Center. For further information, Circle 140 on the TSP Request Card. LAR-13466



Analysis of Scramjet Inlets

Viscous flow can be accounted for in the computations.

The NASCRIN program analyzes two-dimensional flow fields in supersonic-combustion ramjet (scramjet) inlets. It solves the two-dimensional Euler or Navier-Stokes equations in conservative form by an unsplit, explicit, two-step finite-difference method. A more recent explicit/implicit, two-step scheme has also been incorporated for the analysis of viscous flow. An algebraic, two-layer eddy-viscosity model is used for the turbulent-flow calculations.

NASCRIN can analyze both inviscid and viscous flows with no struts, one strut, or several struts embedded in the flow field. It can be used in a quasi-three-dimensional sense for some scramjet inlets under certain simplifying assumptions. Although developed for supersonic internal flow, NASCRIN may be adaptable for other flow problems. In particular, it should be readily adaptable to subsonic inflow with supersonic outflow, supersonic inflow with subsonic outflow, or fully subsonic flow.

The NASCRIN program is available in

vectorized as well as scalar form. The vectorized version, developed in 1983, is written for CDC CYBER 205 computer, whereas the scalar version, developed in 1985, can be run on CRAY or other scalar computers. The code has a central-memory requirement of approximately 300K words for a grid size of about 3,000 points.

These programs were written by Ajay Kumar of Langley Research Center. For further information on the vectorized version, LAR-13297, Circle 144 on the TSP Request Card. For further information on the scalar version, LAR-13559, Circle 145 on the TSP Request card. LAR-13297 and LAR-13559



Solving Ordinary Differential Equations

Initial-value problems are solved via a variable-order Adams method.

The initial-value ordinary differential equation solution via a variable order Adams method (SIVA/DIVA) package is a collection of subroutines for the solution of nonstiff ordinary differential equations. There are versions for single-precision and double-precision arithmetic. SIVA/DIVA requires fewer evaluations of derivatives than do other variable-order Adams predictor/corrector methods. An option for the direct integration of second-order equations can make the integration of trajectory problems significantly more efficient.

Other capabilities of SIVA/DIVA include the following: monitoring user-supplied functions for sign changes, dynamically controlling the step size, flexible control of output, saving the solution, and reverse communication where subroutines return to the user for output or computation of derivatives instead of automatically performing calculations. The user must supply SIVA/DIVA with the following: (a) the number of equations; (b) initial values for the dependent and independent variables, integration-step size, error tolerance, etc.; and (c) the driver program and operational parameters necessary for subroutine execution. SIVA/DIVA contains an extensive library of diagnostic messages for use when errors occur during execution.

SIVA/DIVA is written in FORTRAN 77 for batch execution and is machine-independent. This program was developed in 1983.

This program was written by Fred T. Krogh of Caltech for NASA's Jet Propulsion Laboratory. For further information, Circle 110 on the TSP Request Card. NPO-16699

Do You Feel Lucky???



Good programming isn't a matter of luck. It requires skill, perseverance and good programming tools. You already have the skill and perseverance; **Janus/Ada** provides the programming tools. Tools you can rely on in any project, in almost any MS DOS environment, with full portability to any other Ada system. With **Janus/Ada**, you get lucky in all the right ways:

SYSTEM REQUIREMENTS: Any Intel 86 family processor with 512K RAM, two floppy disk drives or a hard disk and DOS 2.0 or higher.

COMPILATION SPEEDS: 8086/6MHZ:300 lines per minute; 80186/8MHZ: 500 lines per minute; 80286/8MHZ: 900 lines per minute (DOS 3.0)

PRODUCT SUPPORT: Quarterly newsletters, 24 hour Bulletin Board, and a staff with over 20 man years of actual Ada programming experience.

APPLICATIONS AND TOOLS: Assemblers, disassemblers, Ada source code, a Pascal to Ada translator, 8087 support, tutorials and more!

AFFORDABILITY: Our **Janus/Ada "C" Pak** is available for \$99.95 and contains the **Janus/Ada Compiler and Linker**, designed specifically for microcomputers and consumer tested since 1981. Our customers can upgrade to our development and embedded systems "paks" with 100% credit for this starter package. Our **Janus/Ada Extended Tutorial** is available for the same low price. We feature commercial and educational "site" licensing for all of our packages.

ADA STANDARDIZATION: **Janus/Ada** source code can be ported to any validated Ada system and compiled. We offer a variety of tools and consultations to assist you in this process, if needed.

JANUS/ADA USERS: Over 5,000 separate sites use the **Janus/Ada** compiler for training, embedded systems and applications each day. We supply our tools to the U.S. Armed Forces, Fortune 500 companies and over 400 educational institutions, as well as to individuals like you.

We've been making programmers lucky with our tools for over 5 years; isn't it about time you changed your luck? We'll even pay for the call! To place an order or receive our informative brochure, please call 1-800-722-3248. It'll make your day!!!

CP/M, CP/M-86, CCP/M-86 are trademarks of Digital Research, Inc.
*ADA is a trademark of the U.S. Department of Defense
MS-DOS is a trademark of Microsoft

© Copyright 1986 RR Software



SOFTWARE, INC.

specialists in state of the art programming

P.O. Box 1512 Madison, Wisconsin 53701
(608) 244-6436 TELEX 4998168

1-800-722-3248

Circle Reader Action No. 467

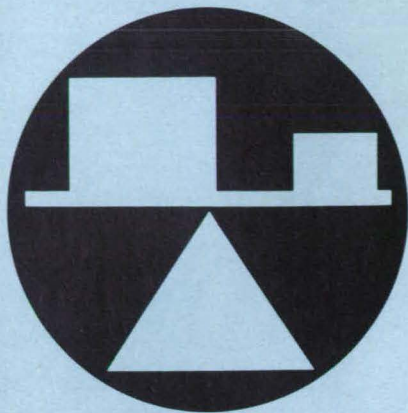

Hardware, Techniques, and Processes

- 44 Quick-Release Panel Fastener
- 46 Duplex Wrench
- 46 Side-Looking Viewer for Crevices
- 47 Measuring Poisson Ratios at Low Temperatures
- 48 Service-Life Extension of Explosive Escape Devices
- 55 Specimen and Holder for Sliding-Mode Fatigue Tests
- 56 High-Pressure Valve With Controlled Seating Force
- 57 Locating Sonic Lines in Transonic Nozzles
- 58 Large Wire Strain Gauges
- 59 Design Improvement for Airplane-Engine Nacelles

Books & Reports

- 60 Predicting Close Satellite Encounters
- 60 Station-Keeping Maneuvers for Geosynchronous Spacecraft

Computer Programs

- 42 Thermal-Analysis Program
- 42 Buckling Analysis of Rectangular Plates with Holes

Quick-Release Panel Fastener

The twist of a handle activates and deactivates a clamp.

Lyndon B. Johnson Space Center, Houston, Texas

A quick-release fastener for panels can be actuated with just one hand. The fastener has no loose parts, does not require mating hardware, and can be used in a blind hole in the mating panel.

The new panel fastener is a self-contained unit that extends through congruent holes in the two panels to be joined. The unit contracts to clamp the panels together and expands to release them.

The shaft housing of the fastener is installed in a counterbore in panel 1 and

held there by a nut (see figure). A handle is attached to the shaft with a press-fit pin. The end of the shaft opposite the handle is inserted in the shaft housing, and a split-collar assembly with O-rings, a cam washer, and an adjustment nut are assembled on the shaft. The unit is then ready for use.

The shaft is inserted in panel 2, and the handle is turned so that its axis is perpendicular to the shaft axis. This action forces the adjustment nut and washer

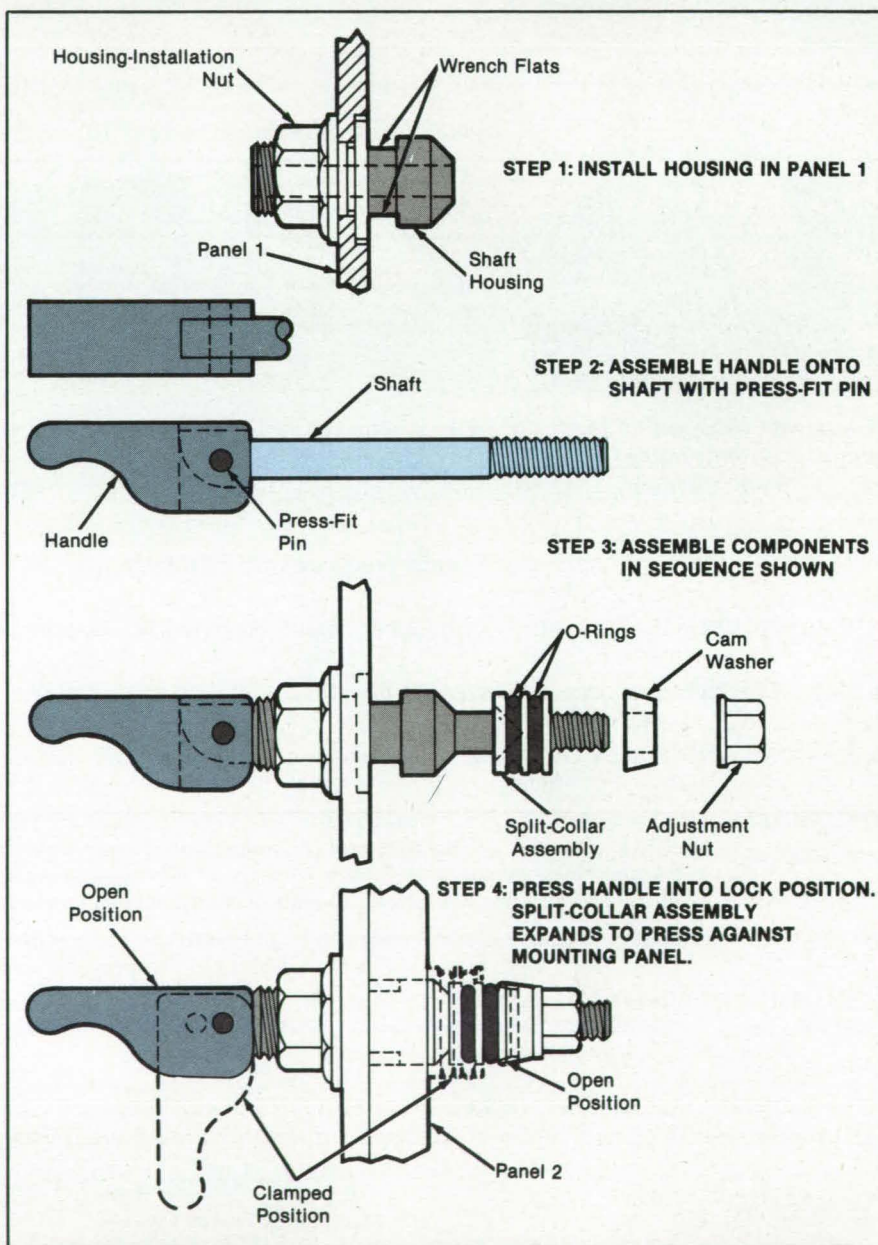

Installation of the Quick-Release Fastener is fast and easy. A 90° rotation of the handle after installation is all that is needed to clamp together or release a pair of panels.

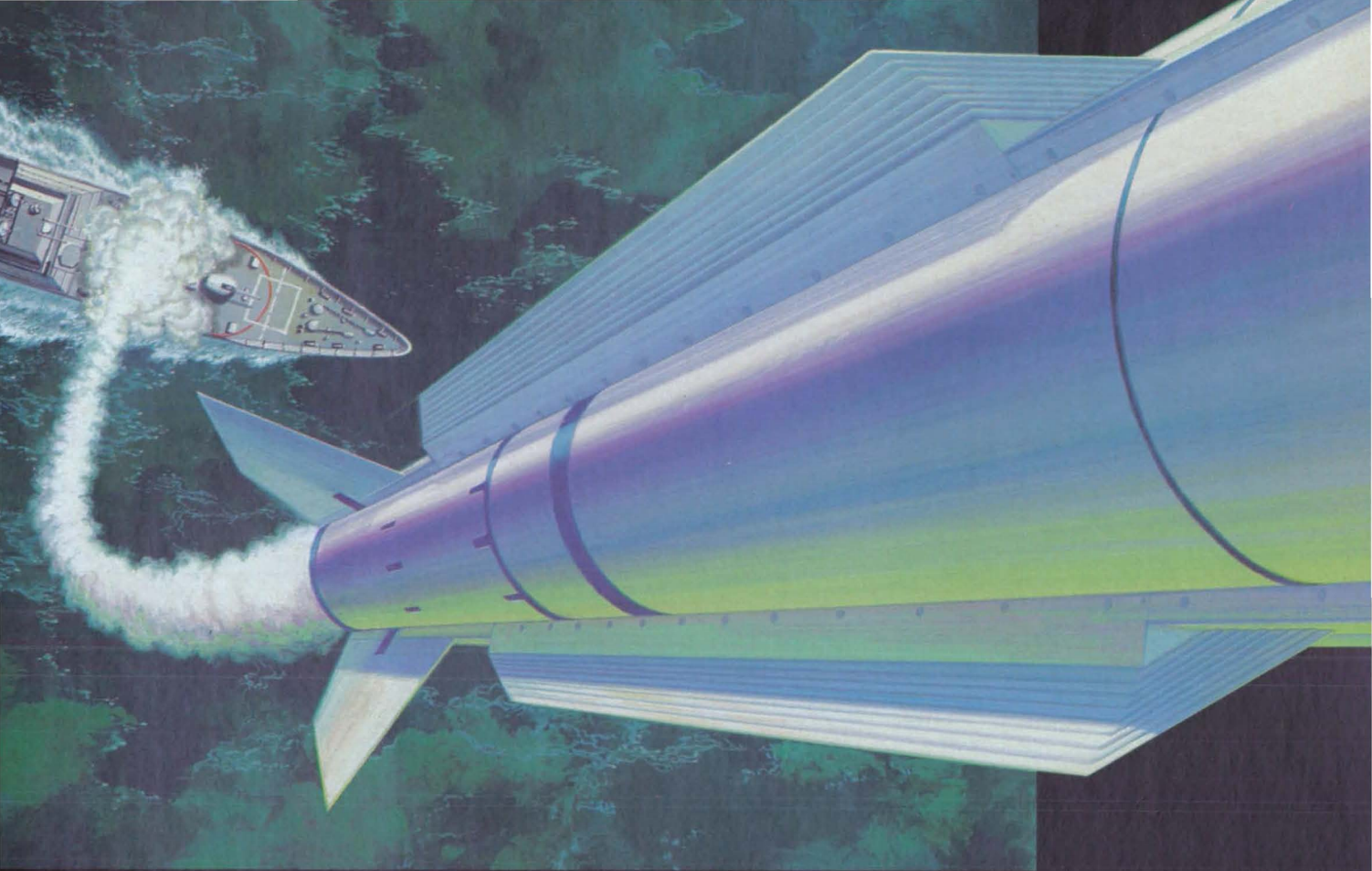

How does Heath Tecna guarantee the dimensional stability of 22-ply graphite missile fins?

With unprecedented tooling design and breakthrough production techniques. Case study: General Dynamics' SM-2 ship-to-air missile.

General Dynamics' Challenge:

Extend missile range and speed with lightweight yet exceptionally rigid composite fins. Dimensionally accurate to .010". Ply orientated to within 5° absolute alignment. Free of potential delam. Resistant to beyond 650°F. And deliverable at 80 per month with surge capacity to 200.

Heath Tecna's answer:

"Terraced" master molds eliminate slippage of the 22 plies of .015" thick graphite-and-

polyimide prepreg layers during compression molding. A proprietary-cure process prevents polyimide resin's tendency to produce gas-caused voids and delaminations. And automated process controls guarantee consistent predictable quality at high production rates.



Missile fin cross-section showing "terraced" profile

Preferred by the primes.

We combine design specs with the realities of manufacturing. With 500,000 sq. ft. of advanced composites facilities. Autoclaves up to 16' x 43'. 3-D core carving capability. In-house materials properties and characterization lab. And 850 employees whose confidence

and capabilities may be the difference between hitting pay dirt ... or the deep blue sea.

A tool for your time.

Call VP/Jim Martenson with your challenge at 206-872-7500 ext. 116. We'll provide case histories ... and a free pocket slide guide comparing composites properties to various metal alloys.

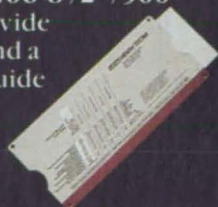

Designers and fabricators of advance composite structures ... for over 20 years.

CRITON HEATH TECNA

Criton Technologies
Air Transportation
Products Group

against the split-collar assembly, pushing the assembly up the taper of the shaft housing so that the split collar expands beyond the hole and clamps panel 2

against panel 1.

This work was done by David R. Fosdick and Robert C. Phillips of Rockwell International Corp. for **Johnson**

Space Center. For further information, Circle 15 on the TSP Request Card. MSC-20767

Duplex Wrench

A special tool enables one worker to do a two-worker job.

Lyndon B. Johnson Space Center, Houston, Texas

A special wrench holds two nuts in place while a third nut, coaxial with the others, is turned. The wrench was developed for tightening delicate couplings on a gas-supply panel. With it, a single operator can restrain the coupling pressure cap and the connector body nut with one hand. The other hand is free to tighten the coupling nut with a torque wrench.

Previously, two operators using three wrenches were needed for the job. The operators often had difficulty coordinating their actions and sometimes damaged the parts. (The mating surfaces in the coupling must not be rotated on each other or else the seal will be broken, and costly repairs will be necessary.) The tightening operation was especially awkward in close quarters.

The wrench has two heads on a common shaft (see figure). The offset section secures the flats of the connector-body nut, which is flush against the panel. The straight section holds the pressure cap. Immobilizing these parts with the duplex

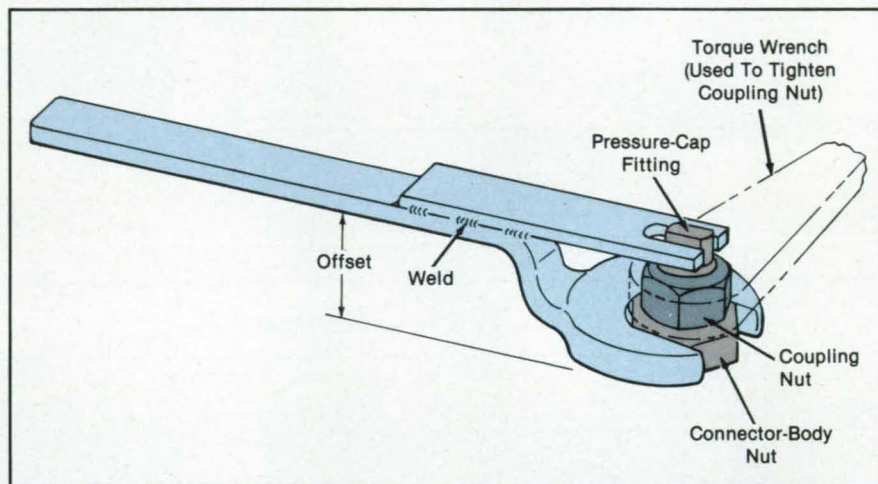

The **Duplex Wrench Holds Two Parts** of a pressure fitting while the nut between them is turned with another wrench. The concept can be adapted to other three-wrench operations on coaxial nuts.

wrench, the operator turns the coupling nut to the required tightness.

This work was done by Charles N. Canada of Rockwell International Corp.

for **Johnson Space Center.** For further information, Circle 17 on the TSP Request Card. MSC-20585

Side-Looking Viewer for Crevices

Gaps only 1 mm wide are inspected with a thin metal mirror.

Lyndon B. Johnson Space Center, Houston, Texas

A side-looking optical viewer can be inserted into a gap 1 mm wide to a depth of 10 cm. The instrument allows a human observer to inspect small crevices from a comfortable viewing angle (see figure).

A small mirror atop a pair of thin, flat legs is inserted into the gap. The mirror reflects an image of the gap wall or other object into a microscope, which magnifies the image 20 times. A quartz/halogen lamp in a separate unit provides light to illuminate the gap via an optical-fiber bundle. The observer can look directly through the microscope or can attach a photographic or video camera without disturbing the setup.

The mirror is made from hardened,

polished tool steel. It is soldered to the two legs to give a viewing angle of 102°, 90°, or 86° with respect to the microscope axis. A mirror can thus be selected to look at the interior of the gap either perpendicularly to the line of entry or from a slightly inward or slightly outward direction. The legs, made of stainless-steel strips 0.032 in. (0.81 mm) thick, hold the mirror 4.5 in. (11.4 cm) from the microscope objective lens. The legs are mounted in a crossbar at the base of the microscope.

The microscope, a commercial model, was modified in several ways. An extension was added in front of the erecting prism to provide the proper working dis-

tance for the 80-mm objective lens. Internal baffles and nonreflective surfaces were installed in the microscope tube to reduce the glare caused by the intense illumination in the gap.

The intensity of light from the lamp can be controlled. The 72-in. (1.83-m) fiber bundle carries the light to a lens near the base of the mirror-supporting legs. The lens projects the light into the gap.

For direct viewing, any of three eyepieces can be selected for greatest viewing comfort in various working positions: a straight eyepiece, a 60° eyepiece, and a 90° eyepiece. The last two contain erecting prisms that provide an uninverted image. Their angles are conve-

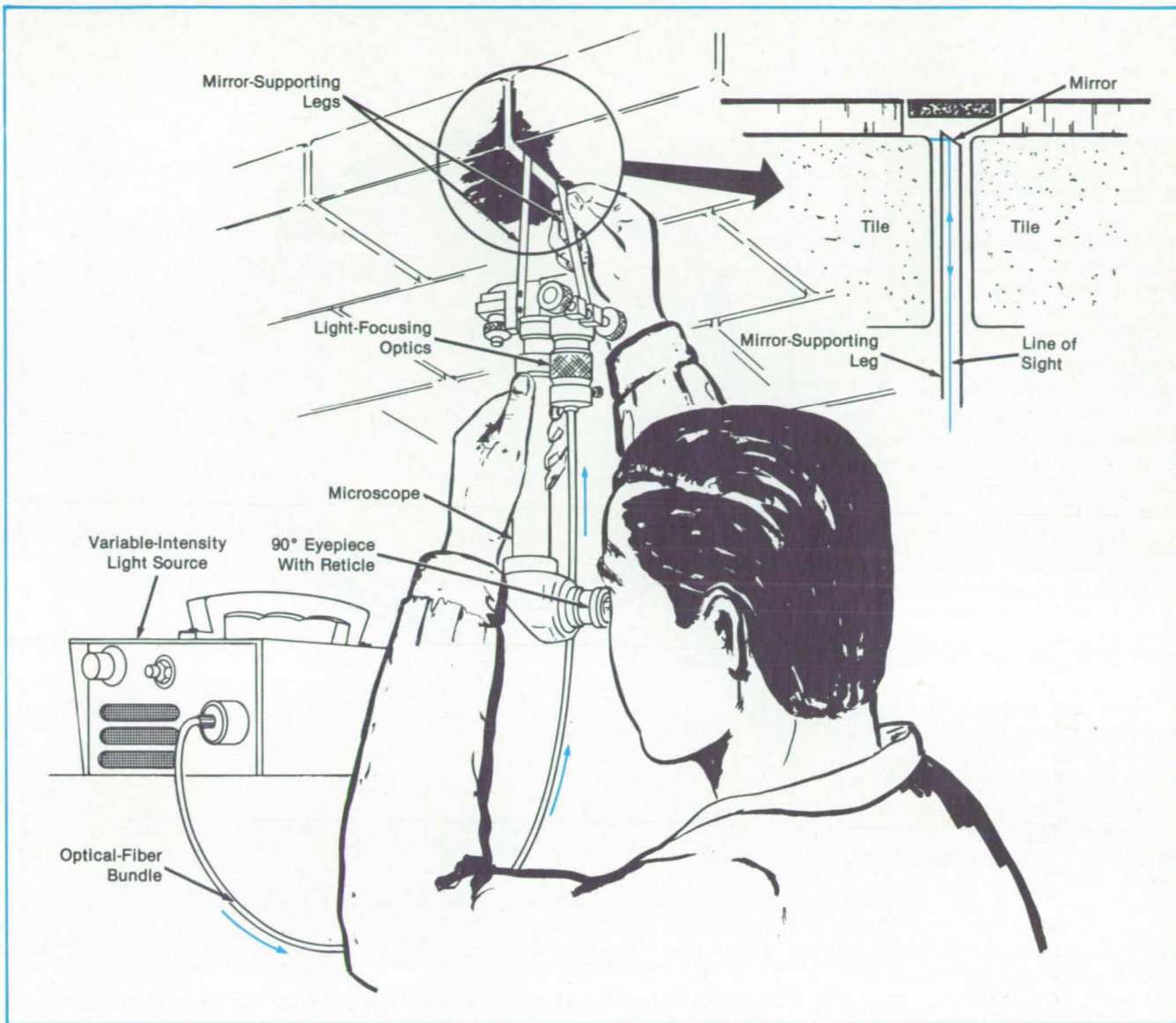

An Observer Inspects the gap between a pair of tiles, using the side-looking optical viewer. A long, narrow metal mirror in the gap reflects an image to the microscope.

nient for overhead work. Each eyepiece contains a reticle graduated in 0.002-in. (0.05-mm) divisions so that the observer can estimate dimensions.

A single-lens reflex camera was modified so that its viewfinder can look through the straight eyepiece. The camera is sup-

ported for its 5- to 20-second exposures by a tripod consisting of a bipod plus an adjustable stop on one of the mirror legs.

A small, lightweight video camera provides a high-quality color picture for remote viewing or recording. Because the camera uses a charge-coupled de-

vice instead of a vidicon tube, ghosts and blooming do not mar the image.

This work was done by George R. Hagen of Rockwell International Corp. for Johnson Space Center. For further information, Circle 21 on the TSP Request Card. MSC-20610

Measuring Poisson Ratios at Low Temperatures

A simple extensometer ring measures the bulges of specimens in compression.

Marshall Space Flight Center, Alabama

A new method of measuring Poisson's ratio can be used on brittle ceramic materials at cryogenic temperatures. Ordinarily, Poisson's ratio (the ratio of the change in relative thickness of a specimen under tensile or compressive stress to its change in relative length) is determined by placing a specimen in tension

and measuring the decrease in thickness and the increase in length. However, ceramics tend to fracture at low temperatures when placed under tension, and the conventional method cannot be used.

In the new method, Poisson's ratio is measured in compression instead of in tension. A cylindrical column of stacked

ceramic disks is compressed axially on a testing machine. The increase in diameter resulting from the compression load is measured by a specially designed extensometer ring, and the decrease in length is measured in the conventional way.

The extensometer ring consists of inner and outer segments, the tips of which

are separated by a gap (see figure). The inner segment is a thin aluminum band that makes contact with the circumference of the specimen. The outer band presses the inner band lightly against the specimen and holds strain gauges, which vary in resistance as the gap changes. The ring, therefore, produces an electrical output that varies with the specimen circumference. The output can be readily calibrated to give the change in diameter as a function of the output signal, and a plot can be made of the change in diameter as a function of the change in length.

The ring is designed for a specimen 2.5 in. (6.35 cm) in diameter. To allow for thermal contraction and specimen variability and to provide an adequate measurement range, the working range of the extensometer is from a diameter of 2.4 in. to just under 2.6 in. (6.1 to 6.6 cm). The specimen stack is 7.7 in. (19.6 cm) long and is made of 11 disks, each 0.7 in. (1.8 cm) thick, bonded together at the axis with epoxy adhesive.

This work was done by Robert S. Boozon and John A. Shepic of Martin Marietta Corp. for **Marshall Space Flight Center**. For further information, Circle 114 on the TSP Request Card.

Inquiries concerning rights for the commercial use of this invention should be addressed to the Patent Counsel, Marshall Space Flight Center [see page 19]. Refer to MFS-28107.

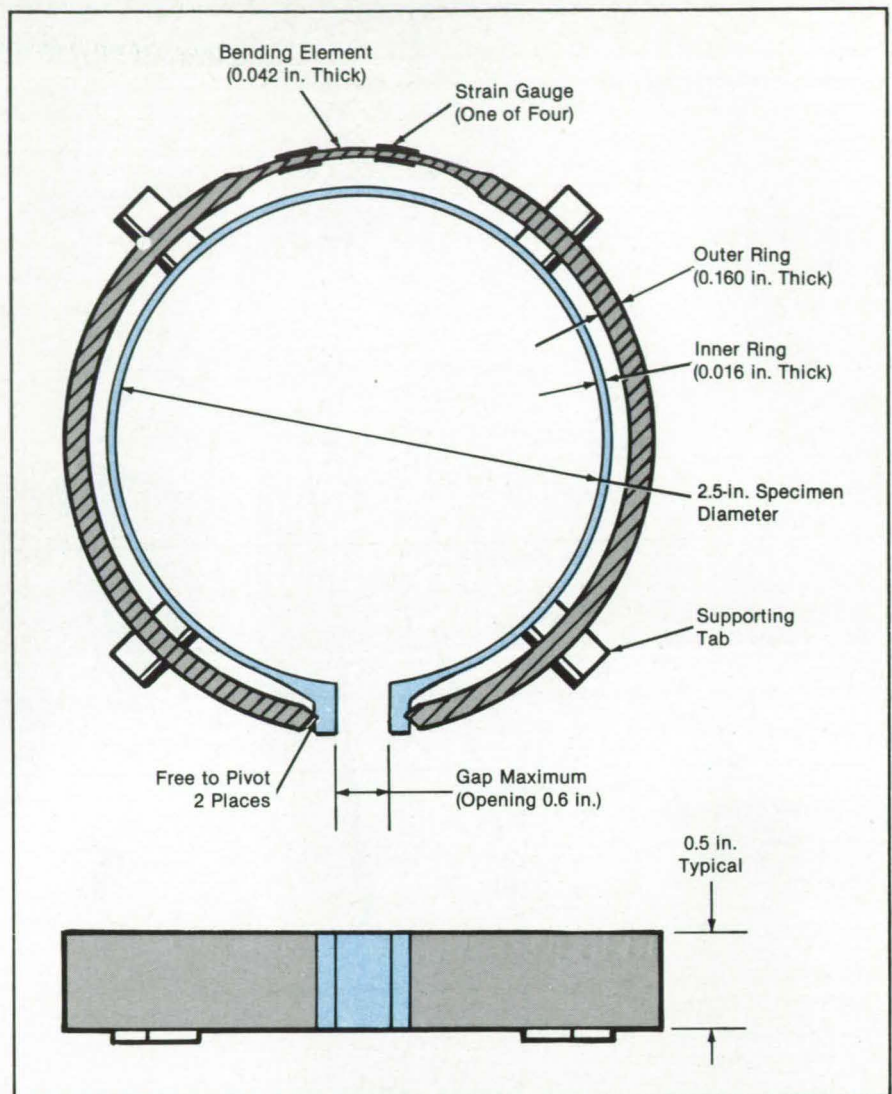

The **Extensometer Ring** encircles a cylindrical specimen. Its four strain gauges are connected in a fully active Wheatstone bridge that is self-temperature-compensating. It can be used at temperatures as low as that of liquid helium.

Service-Life Extension of Explosive Escape Devices

Chemical and functional tests yield conservative service-life estimates.

Langley Research Center, Hampton, Virginia

An approach to the extension of the service lives of explosive devices in aircraft escape systems has been developed, supported by testing of representative candidate devices to evaluate quantitatively the effects of service, age, and degradation, and to enable responsible, conservative service-life determinations. Five types of explosive components were evaluated: rigid and flexible explosive transfer lines; one-way transfers; flexible, linear-shaped charges; and initiation-handles.

A wide variety of explosive devices has been successfully applied to military and NASA aircraft to provide emergency escape for the flight crews. The establish-

ment of the rated service life was previously approached on a very conservative basis because the function involved is critical to human life. Generally, a relatively short service life was arbitrarily established.

The extension of service in a realistic manner provides both cost savings and increased system reliability. Removal and replacement costs that can be reduced include those associated with the removal of the aircraft from service, transfer of the aircraft to and from refurbishment sites, procurement of replacement components, and use of a specially trained labor force. System reliability can be increased by avoiding too frequent teardown and re-

placement of the devices, with the accompanying potential for damage and improper assembly.

The devices were evaluated functionally and chemically. Velocity measurements were made of detonation fronts and of explosively driven fragments, and output energies were measured on several devices. The status of the explosive materials in the devices was determined using color photographs, scanning electron microscopy, and high-pressure liquid chromatography, which provides the quantity of each explosive by weight in a sample. Samples of each test group were dissected at several points for analysis. A series of nondestructive tests was also conducted,

Multiple Pages Intentionally Left
Blank

and "performance-standard" groups were used to establish functional and chemical composition standards against which all subsequent test groups were compared. Repeat thermal-qualification tests and degradation investigations were also conducted on some of the devices.

The results of the program indicate that this test methodology (inspection, chemical, and functional) should be incorporated into the original specifications for explosive devices and then used for subsequent evaluation testing. "Accelerated aging" techniques should not be applied, because there is no verified relationship to age or service.

Rigid explosive transfer lines and one-way transfers should be considered for service extension for all applications. Flexible explosive transfer lines should allow only thermal-annealing cycles that do not exceed 350 °F (177 °C), and service extension should be cautious when these devices are used. Flexible linear-shaped-charge applications should provide mechanical support of end tips to maintain seals and performance, and service extension should be cautious. For initiation handles, service extension should be approached with extreme caution because of the difficulty of fully evaluating all explosive components, particularly the percussion

primers, which are the weakest components in these devices.

This work was done by Laurence J. Bement of Langley Research Center and Morry L. Schimmel of McDonnell Aircraft Co. Further information may be found in NASA TM-86323 [N85-22381/NSP], "Approach for Service Life Extension of Explosive Devices for Aircraft Escape Systems."

Copies may be purchased [prepayment required] from the National Technical Information Service, Springfield, Virginia 22161, Telephone No. (703) 487-4650. Rush orders may be placed for an extra fee by calling (800) 336-4700. LAR-13462

Specimen and Holder for Sliding-Mode Fatigue Tests

A single-ended notch design facilitates accurate measurements of crack progression.

Lewis Research Center, Cleveland, Ohio

A novel test specimen and a novel loading fixture have been developed for the fatigue and fracture testing of materials under Mode II, or sliding-mode, loading. Such testing is required for the analysis of failures in structural materials, bearings, and the like. Under Mode II loading, fracture in this specimen proceeds in a direction that is in line with the starter notch (see Figure 1), as half of the specimen "slides" vertically past the other half, analogously to the sliding of half a deck of cards past the other half. Important features of this specimen are that a nearly-pure Mode II condition exists at the test zone and that the single-ended notch design permits the simple, accurate measurement of crack progression.

Examples of the type of fracture and fatigue cracking obtained with this specimen are shown in Figure 2. Analyses of the specimen have been performed using finite-element and boundary-collocation methods.

A method of introducing measured amounts of Mode I (opening-mode) loading has also been developed for this specimen for mixed-mode (I and II) testing. This method utilizes fixed/controlled separation of the pins at the free end of the test specimen.

This work was done by Robert J. Buzzard, George Succop, and Bernard Gross of Lewis Research Center. Further information may be found in:

NASA TM-83722 [N84-29248/NSP], "Mode II Fatigue Crack Growth Specimen Development," and

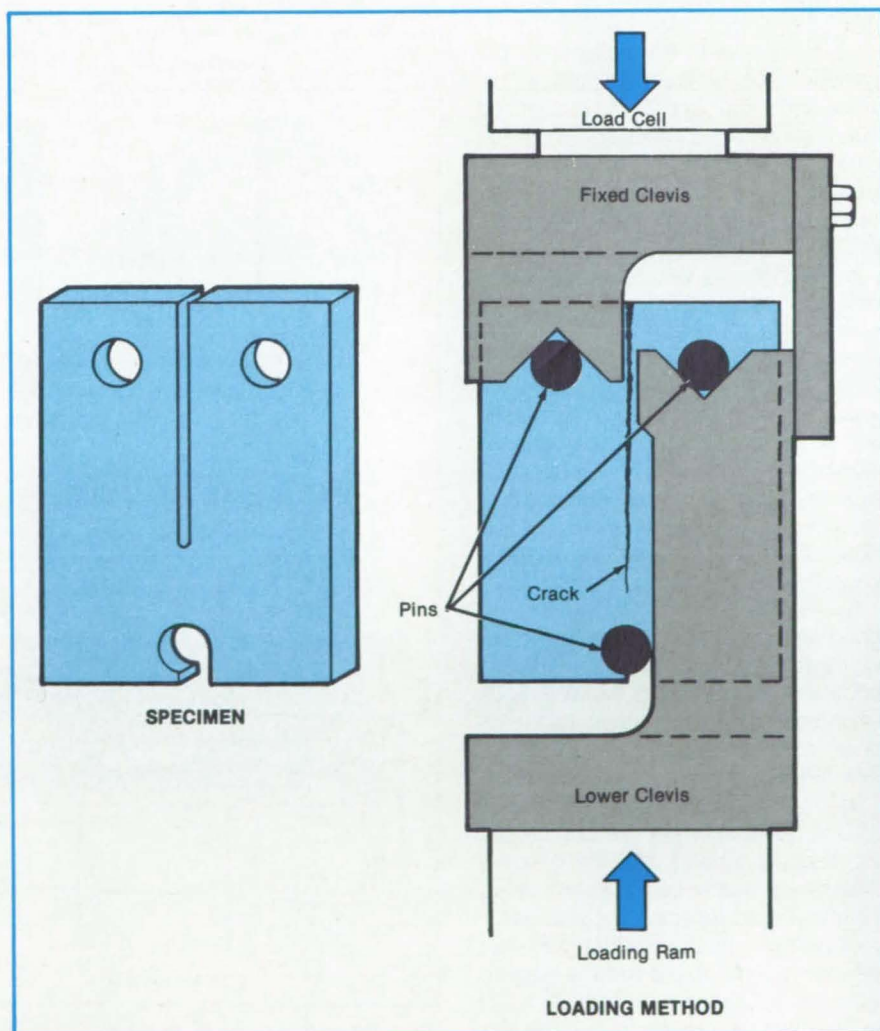

Figure 1. In **Mode II Testing**, the specimen is placed in a slotted testing fixture. A compressive load is applied through pins, causing the specimen to crack as shown.

NASA TM-86908 [N85-16205/NSP],
 "Experimental Compliance Calibration
 of the NASA Lewis Research
 Center Mode II Fatigue Specimen."

Copies may be purchased [prepayment
 required] from the National Technical In-
 formation Service, Springfield, Virginia
 22161, Telephone No. (703) 487-4650.
 Rush orders may be placed for an extra
 fee by calling (800) 336-4700.

This invention is owned by NASA, and
 a patent application has been filed. In-
 quiries concerning nonexclusive or ex-
 clusive license for its commercial de-
 velopment should be addressed to the
 Patent Counsel, Lewis Research Center
 [see page 19]. Refer to LEW-14281.

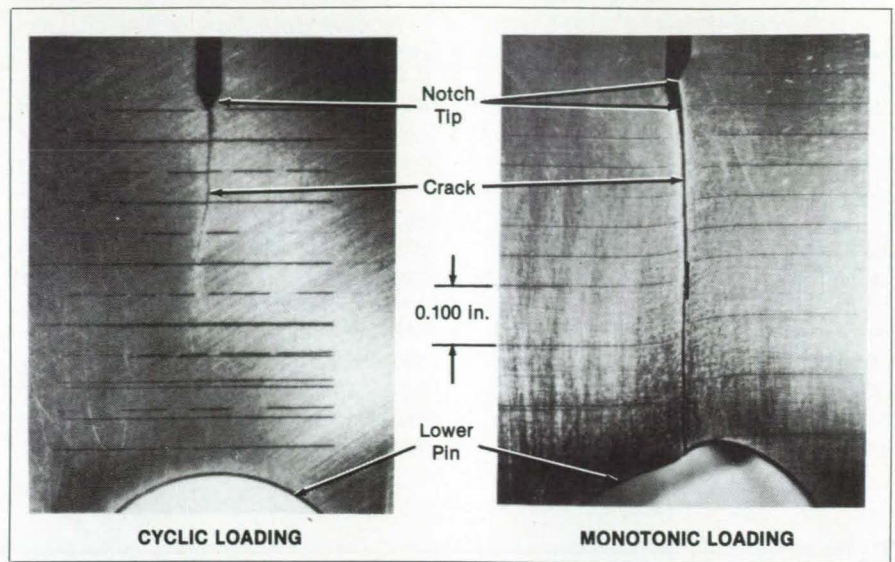

Figure 2. These **Mode II Test Specimens** were subjected to two different kinds of loading, resulting in two different cracking patterns.

High-Pressure Valve With Controlled Seating Force

The poppet and seat are less likely to be damaged by faulty operation.

Lyndon B. Johnson Space Center, Houston, Texas

Improvements in a widely-used high-pressure valve increase the accuracy of preloading of the poppet. The redesigned valve also prevents metal shavings and other debris from developing during operation, installation, or removal. New features include a secondary seal in the cap.

In the previous version of the valve, the poppet was seated and preloaded by use of a torque wrench to apply a predetermined torque to a swivel nut that drove the poppet. However, this procedure sometimes damaged the valve seat if the torque wrench was not set properly or was poorly calibrated or because variations in valve properties or conditions altered the torque/preload relationship. The damage could spring a leak of pressurized gas or hydraulic fluid.

The new version of the valve uses the spring force of Belleville washers to apply, control, and limit the preload on the poppet seat. The length of the valve body is increased slightly to accommodate the washers, which are placed around the neck of the body (see figure). When the swivel nut is first tightened, the washer with the least stiffness will bottom out first, and the washer with the greatest stiffness will hardly be deflected. If the swivel nut is tightened further, the washer of medium stiffness will be the next one that deflects to preload the poppet. Still more tightening will cause the first two washers to bottom out, and the stiffest washer will then begin to deflect.

Thus, in a random sample of three

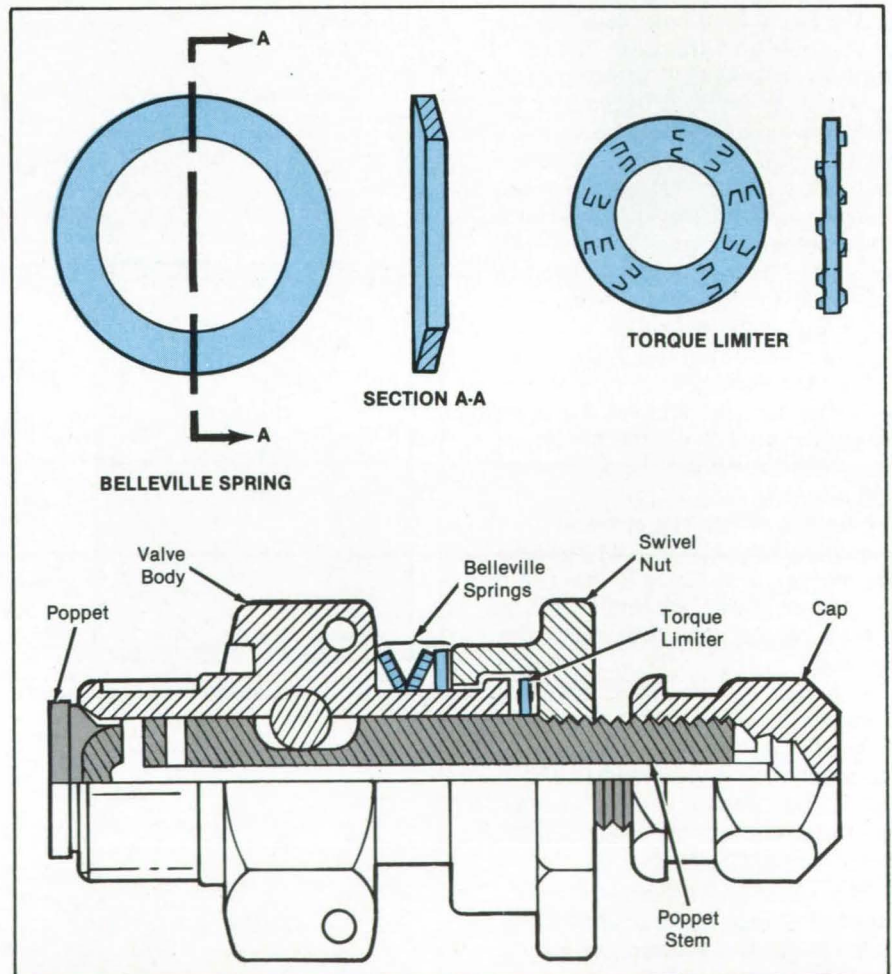

Belleville washers create a **Precise Value of Seating Force**. If an installer should attempt to exceed that force, the torque limiter gives tactile and aural warning and makes further force increases difficult.

washers, the washer that most closely matches the design stiffness can be selected, by progressive tightening, to be the one that provides the preload force. If that selected washer should fail, the bottomed-out washer will take over; the valve will still operate correctly but at a slightly lower preload.

If the swivel nut is tightened beyond the required preload, it comes into contact with the torque limiter, which is a washerlike device at the end of the valve body. The knurled face of the swivel nut

scrapes against projections on the torque limiter, producing vibration and a screeching sound that alerts the installer. At the same time, the projections dig into the knurled surface, making further tightening of the swivel nut increasingly difficult.

The pressure-warning groove has a rounded contour in the new version; the sharp corners of the groove in the old valve design are eliminated. The new contour prevents metal particles from being cut from threads when the valve is assembled and operated. Such particles

could lodge in the poppet seat or flow into the pneumatic or hydraulic system and cause harm.

The stem end is beveled in the new valve so that it sits tightly in a conical ring cavity in the valve cap. The stem and cap thus form a backup seal for the primary poppet seal.

This work was done by Raymond H. Bradley of Johnson Space Center. For further information, Circle 16 on the TSP Request Card. MSC-20932

Locating Sonic Lines in Transonic Nozzles

New formulas predict more accurately the line location in advanced convergent/divergent nozzles.

Marshall Space Flight Center, Alabama

A new set of formulas for the positions of sonic lines enables the more accurate determination of pressures, heat transfers, and flow-discharge coefficients in advanced convergent/divergent nozzles. Older, closed-form approximate solutions of the Sauer type were used to determine the best position. However, in advanced nozzles with shorter transonic fields, such approximations are no longer adequate.

The Sauer solution is described in A. H. Shapiro, *The Dynamics and Thermodynamics of Compressible Flow*, vol. 2, pp. 826-836, Ronald Press Co., 1953. The Sauer approximation for a two-dimensional (flat) nozzle is as follows:

$$\Delta x/y = -[(\gamma + 1)R_T/9R_U]^{1/2}$$

For an axisymmetric nozzle, the approximation is the following:

$$\Delta x/y = -[(\gamma + 1)R_T/32R_U]^{1/2}$$

In both cases Δx is the axial displacement of the sonic line, y is the distance from the axis to the point on the wall where Δx is measured, R_U is the radius of curvature of the nozzle throat in a plane that includes the axis, R_T is the distance from the axis to the throat at the narrowest part, and γ is the ratio of the specific heat of the flowing gas at constant pressure to that at constant volume. The minus sign indicates a displacement upstream.

Where R_U/R_T lies between 1 and 5, the new approximations are as follows:

$$\Delta x/y = -[(\gamma + 1)R_T/140R_U]^{0.4}$$

for round nozzles and

$$\Delta x/y = -[(\gamma + 1)R_T/40R_U]^{0.4}$$

for flat nozzles.

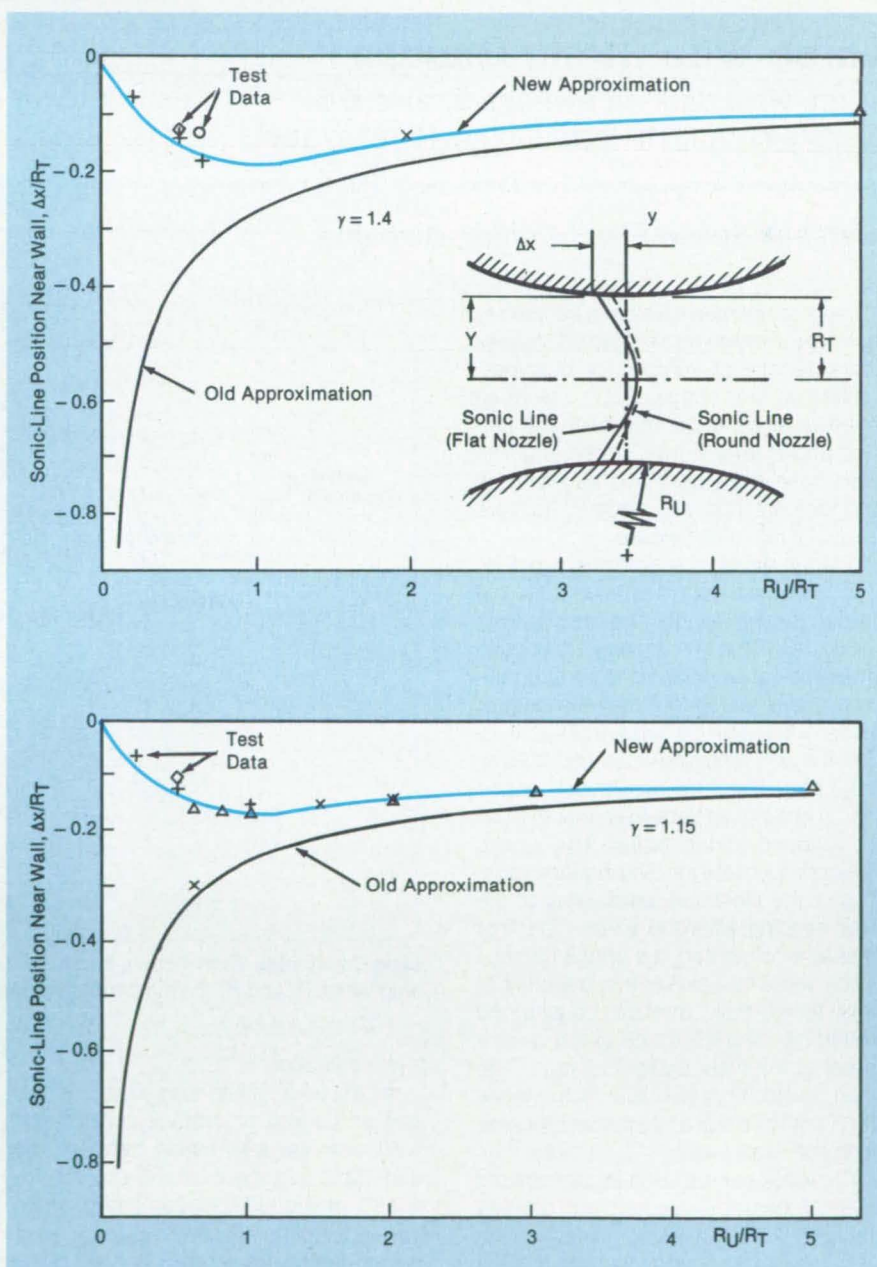

Figure 1. Plots Compare Positions of sonic lines computed by old and new methods (solid and dashed lines, respectively). The plot for the new method is much closer to measured data points (dots).

Where R_U/R_T lies between 0 and 1, the new approximations are

$$\Delta x/R_T = -[0.09R_U/(\gamma + 1)R_T]^{0.5}$$

for round nozzles and

$$\Delta x/R_T = -1.88[0.09R_U/(\gamma + 1)R_T]^{0.5}$$

for flat nozzles.

Figure 1 compares the old and new approximations with measurements taken on the round nozzle shown in Figure 2.

This work was done by William R. Wagner, Frank F. Lepore, and Bernard J. Ostermier of Rockwell International Corp. for **Marshall Space Flight Center**. No further documentation is available. MFS-29163

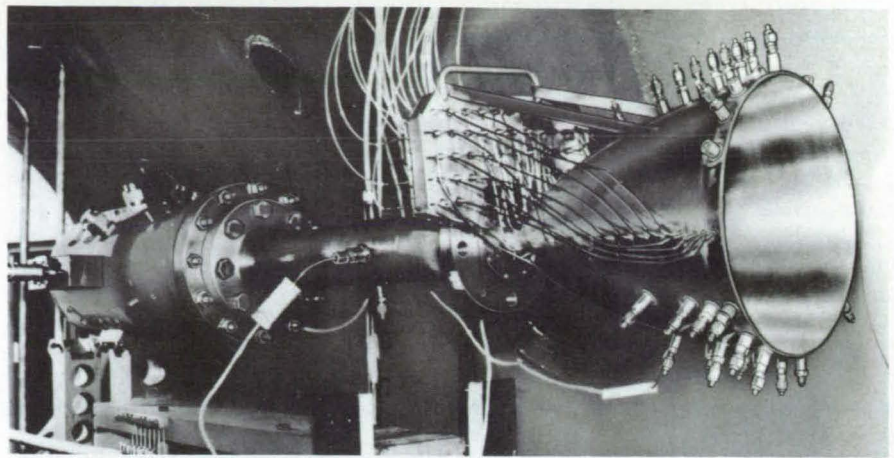

Figure 2. This **Sharp-Radius-Throat Test Nozzle** for the Space Shuttle main engine was used in experiments to verify the new equations.

Large Wire Strain Gauges

Wires yield data on average strains over distances ranging from inches to many feet.

Marshall Space Flight Center, Alabama

Long constantan wires can be used to measure average strains over distances characteristic of vehicles or buildings. Connected in a bridge circuit, the wires measure strain accurately (within 1 percent) and linearly (within 0.1 percent). The wires have been stretched as much as 0.15 percent and still returned to zero residual strain after release.

A strain gauge, for example, might be constructed with four enameled wires laid side by side (see figure). Two straight wires 0.005 in. (0.13 mm) in diameter are bonded with strain-gauge adhesive to the structure to be measured so that they elongate or shorten along with the surface of the structure. The two remaining wires, of 0.0125-in. (0.32-mm) diameter, are loosely taped nearby in a zigzag pattern so that they do not respond to the strain. The zigzag wires compensate for temperature variations of the electrical resistances of the strain-sensing (straight) wires. The four wires are connected in a bridge circuit.

The wires can be used in a variety of ways; for example, they can be wrapped around the circumference of a pressure vessel at intervals along its length. The strain gauges thus give data on the variation (if any) of strain and internal pressure along the vessel wall.

The wires can be used to average out the small local strain variations caused by cracking; for example, cracking of the resin in a wound-filament vessel. In such a case, it might suffice to use a single-wire gauge without temperature compensation, with a gauge factor obtained from

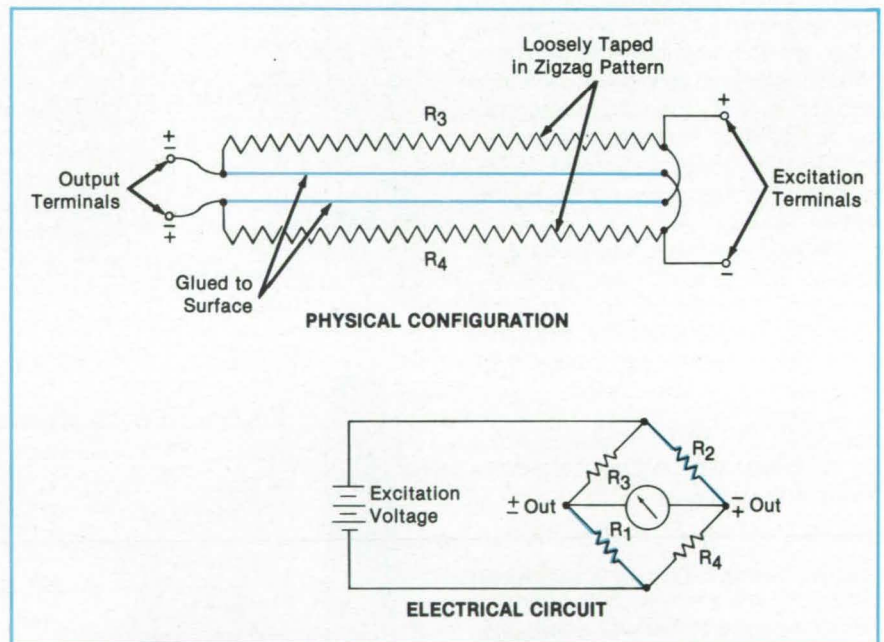

Long Constantan Wires Form a Bridge for the measurement of strain. R_1 and R_2 are the sensing wires. R_3 and R_4 are temperature-compensating sections.

a lot calibration.

A long wire can be tapped at intervals so that the total or average strain measured over the total length between the end taps can be compared with the strains measured between intermediate taps. A wire can also be stretched tightly between end points and not bonded in between, to measure accurately small changes in length over distances of 100 ft (30 m) or more. The wire can be calibrated

in place by use of a micrometer to measure a change in distance between the end points. The calibration is accurate if the wire is maintained free of encumbrances between the end points.

This work was done by Boyd D. Bryner of Thiokol Chemical Corp. for **Marshall Space Flight Center**. No further documentation is available. MFS-28062

Design Improvement for Airplane-Engine Nacelles

Better streamlining reduces drag.

Ames Research Center, Moffett Field, California

An advanced three-dimensional transonic design routine for wing-mounted engine nacelles has been modified to include the effects of propellers and wing sweep. The resulting new nacelle shapes will introduce less airflow disturbance and, therefore, less drag.

Before the modification, the routine had been used to calculate wing airfoil shapes that satisfy boundary conditions imposed as chordwise pressure distributions. The improvement consists of the introduction of boundary conditions in the form of nonuniform onset flow in the area of the wing washed by the propeller slipstream.

The improved routine generates the nacelle shape as a series of cross sections that are swept, relatively to the

unperturbed flow, as a function of wing shape. The collection of points defining the centroids of the nacelle cross sections is made to conform to a line representative of the local flow field. The figure shows a wing with a nacelle shape designed by this method.

This work was done by David F. Vernon, Gregory S. Page, and H. Robert Welge of McDonnell Douglas Corp. for Ames Research Center. For further information, Circle 58 on the TSP Request Card.

Inquiries concerning rights for the commercial use of this invention should be addressed to the Patent Counsel, Ames Research Center [see page 19]. Refer to ARC-11580.

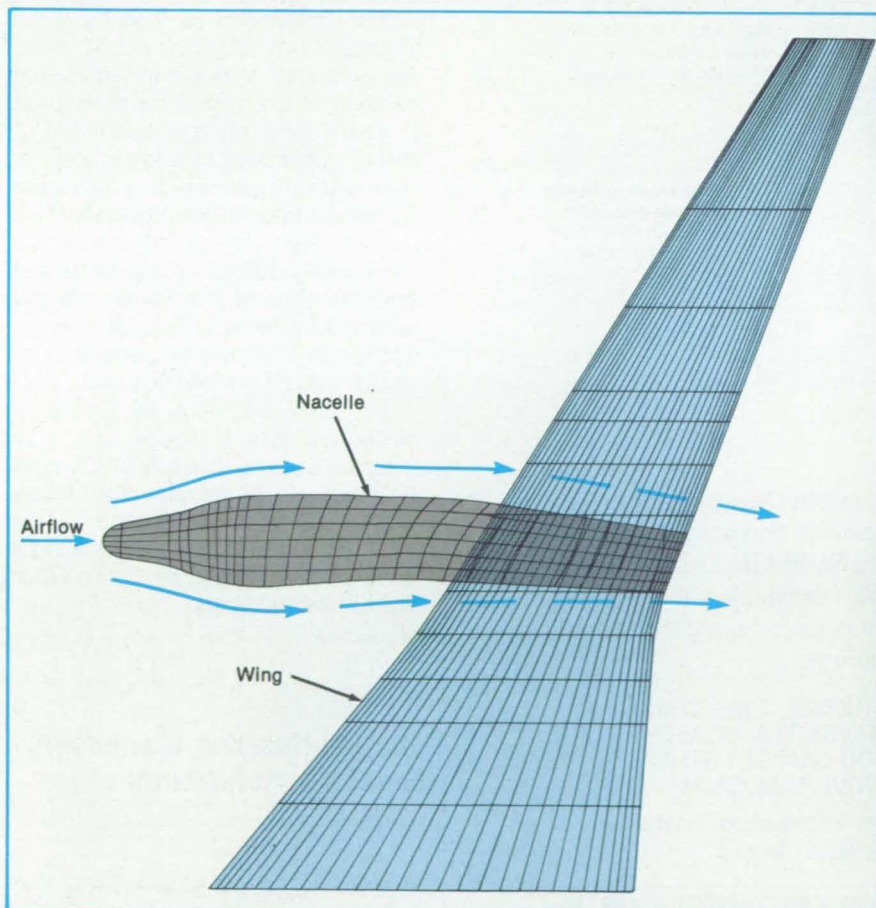

An Engine Nacelle on a Wing has a shape that is swept to conform more closely to the local airflow streamlines. This shape is for an engine and propeller with up-outward rotation.



...DEVELOPED FOR
N.A.S.A.
...USED BY
ASTRONAUTS ON
SPACE FLIGHTS



Chrome Space Pen with flight button point retraction. Refills readily available.

\$10.00



Chrome pocket/purse pen with distinctive Space Shuttle emblem. Unique compact design.

\$15.00



Fisher Space Pens are available wherever better pens are sold. Corporate logos and emblems are available. You may order or request further information by contacting:

PAUL C. FISHER
743 Circle Avenue
Forest Park, IL 60130
(312) 366-5030

Books and Reports

These reports, studies, and handbooks are available from NASA as Technical Support Packages (TSP's) when a Request Card number is cited; otherwise they are available from the National Technical Information Service.

Predicting Close Satellite Encounters

Approaches and possible collisions are predicted statistically.

A method for predicting the probabilities of collisions between nominally geosynchronous satellites gives results without large computer resources. The method, which is described in a paper, realistically assesses the possibility of a collision between an expired, drifting satellite and an active, station-keeping satellite. The math-

ematical techniques in the paper may be useful in the analysis of such terrestrial risks as those of floods and nuclear accidents.

Older prediction methods tend to be primarily statistical or primarily deterministic. In the previous statistical approach, it was assumed that the satellites are uniformly distributed. It does not give information about individual satellites but does provide a rough estimate of the probabilities of collisions in the system of satellites. The deterministic approach, in contrast, uses the equations of motion of the satellites to find when and where pairs of individual satellites will most closely approach each other. It requires accurate data and precise computation. A large computer system and much computer time are needed.

The new method combines aspects of the deterministic and statistical methods. From the equations of motion, one first determines when and where an expired satellite will approach the nearest active satellite over the next several years. Then one uses statistical techniques to assess whether the approaches are close enough for a collision.

The new method uses realistic data on the positions of satellites around the Earth. The equations of motion, including the effects of Sun gravity, Moon gravity, and important nonspherical components of the geopotential are integrated over an extensive period for several hundred expired satellites. Minimum distances of approach to active satellites are calculated. A Weibull distribution function is fitted to these minimum distances to enable statistical extrapolation to collisional radii of the order of meters. For example, one calculation involving 100 active and 54 expired satellites showed that for an average satellite diameter of 5 meters, the expected mean time between collisions lies in the vicinity of 60,000 to 100,000 years.

This work was done by Bernell R. McCormick, John D. Vedder, James W. Compton, and Guy N. Hirsch of McDonnell Douglas Corp. for Johnson Space Center. To obtain a copy of the report, "A New Technique for Predicting Geosynchronous Satellite Collision Probability," Circle 131 on the TSP Request Card.
MSC-21102

Station-Keeping Maneuvers for Geosynchronous Spacecraft

A new strategy saves fuel.

A report discusses three existing strategies for maneuvers that maintain the

ANATOMY OF A SUPER SEAL! (aka Greene, Tweed MSE™)

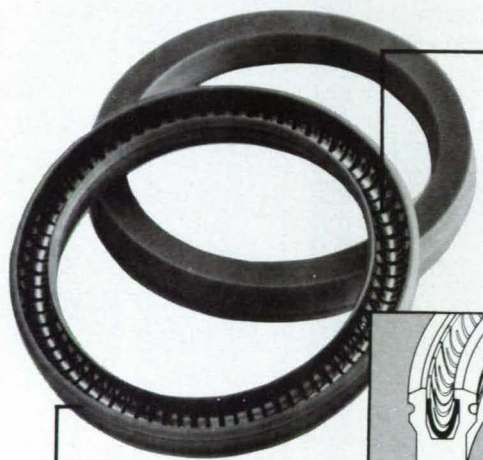

Rugged Metal Spring "Memorgizer" – Energizer spring overcomes PTFE's lack of "memory" and low resilience, keeps lips in tight contact to assure super sealing at low pressure as well as high.

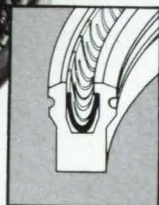

Unique Dual-Lip Design – Doubles sealing action, traps fluid in "wet" applications for additional lubrication.

Smooth Sealing PTFE Jacket – Low friction (no stick/slip), virtually chemically inert, non-contaminating. (Other performance materials for special applications.)

Superb Performance – Seals from vacuum to 20,000 psi, at temperatures from cryogenic to 600F.

Versatility – Dynamic or static. Applications for rod, piston, rotary, and static face sealing. Can be silicon-filled or made with encapsulated spring for clean-in-place applications.

Wide Range of Sizes – 0.100" to 60". Quick turnaround.

Custom Designs – For specials or retrofit.

No Shelf-Life Limitations – Will not deteriorate or bond to other parts during long-term storage.

GREENE, TWEED MSE. MAYBE THE CLOSEST THING YOU CAN GET TO A UNIVERSAL SEAL.

For information, contact Greene, Tweed.

GREENE, TWEED & CO., Inc.

P.O. Box 305 • Kutztown, PA 19443-0305 • (215) 256-9521

apparent position of a geosynchronous satellite and presents a new strategy for a satellite subject to daily momentum-wheel dumps. The new strategy increases the useful lifetime of a satellite by reducing the frequencies and sizes of maneuvers, thereby reducing the rate of fuel consumption.

The longitude of the satellite must be maintained within $\pm 0.05^\circ$ of the assigned value. The adherence to such a close tolerance requires compensation for the combined effects of lunar and solar gravitation (which introduce twice-daily fluctuations of the semimajor axis), solar-radiation pressure (which introduces daily longitude librations), and the tesseral perturbation.

An appropriate station-keeping strategy must enable the satellite to remain within the 0.05° tolerance for the longest possible time between maneuvers. Both the semimajor axis and the eccentricity must be controlled by one or two impulsive velocity changes applied 180° apart in true anomaly. The drift between successive impulses within a maximum period of 24 hours must be calculated to start the cycle at the location that maximizes the cycle period.

In one of the existing strategies, it is assumed that the eccentricity remains negligible so that a single impulse that modifies only the orbital energy will suffice for station-keeping. The maneuvering cycle can be started at any desired longitude within the tolerance range. In the absence of control of eccentricity, this strategy includes the choice of an impulse location that minimizes the post-maneuver eccentricity. Thus, the eccentricity is prevented from increasing at each station-keeping maneuver, and the daily librations in longitude are prevented from growing to larger values. Given the osculating semimajor axis and the true longitude of the pre-maneuver state, it is necessary to calculate the target semimajor axis at the true longitude and the exact initial conditions at that longitude, either to repeat the ideal cycle for the existing tolerance or to go to a new tolerance.

The new strategy extends the one just described by including the effect of the daily momentum-wheel dumps on the daily drift cycle, which is then perturbed by the daily small velocity changes toward the east or west. The strategy includes an algorithm that computes the station-keeping velocity change that brings the spacecraft to the optimum initial conditions to start the drift cycle under the combined effects of the Sun, the Moon, the tesseral harmonics, and all subsequent momentum-wheel dumps.

Like the previous strategy, the new one can be implemented at any longitude starting from a given osculating semimajor axis and true longitude. The algorithm uses an analytic prediction of the postmaneuver

momentum-wheel dumps computed as a function of the right ascension of the Sun, which in turn depends on the apparent orbital position of the Sun as a function of time.

Drift cycles have been calculated for various assigned longitudes, tolerances, and maneuvering longitudes. The results show that taking advantage of the daily momentum-wheel dumps decreases the size of the velocity change required to repeat the drift cycle. The duration of the

cycle is also increased because the variation in orbital energy and the consequent longitudinal drift are not allowed to grow.

This work was done by Jean A. Kechichian of Caltech for NASA's Jet Propulsion Laboratory. To obtain a copy of the report, "Optimal East-West Stationkeeping of Geosynchronous Spacecraft Subject to Daily Momentum Wheel Dumps," Circle 66 on the TSP Request Card.

NPO-16512

ZOC[®] Wave of the future.



Wind Tunnel - Flight Test - Engine Test

Scanivalve's **ZOC**[®] (Zero, Operate and Calibrate) systems are the preferred electronic pressure scanning systems wherever high-data acquisition rates are required.

In addition to Scanivalve's 30 year reputation for integrity and outstanding customer support, consider:

- 50 KHz Scan rates
- 0.1% F.S. accuracy
- Up to 2048 inputs
- RS232 or IEEE-488
- In-situ calibration
- Field replaceable sensors
- The most compact Scanner
- High reliability
- Scanivalve-pioneered technology

Scanivalve is the only manufacturer of both rotary and electronic pressure scanners.

Scanivalve Corp.



10222 San Diego Mission Road • PO Box 20005
San Diego, California USA 92120 • (619) 283-5851/Telex 695023

Machinery

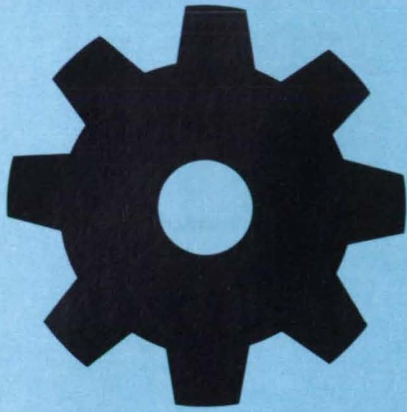

Hardware, Techniques, and Processes

- 62 Magnetic Bearing With Radial and Angular Control
- 63 Three-Axis Attitude Control With a Single Wheel
- 64 Switching Circuit for Shop Vacuum System

Books & Reports

- 65 Characteristics and Applications of Metal Hydrides
- 66 Residential Photovoltaic/Thermal Energy System
- 66 Position Control for Non-linear, Multiple-Link Robots

Computer Programs

- 42 Analysis of Scramjet Inlets

Magnetic Bearing With Radial and Angular Control

The rotor is stabilized magnetically with a feedback control system.

Goddard Space Flight Center, Greenbelt, Maryland

An active magnetic bearing stably levitates its rotor against radial (lateral) and axial motion and points the rotor axis in a controllable direction, yet allows the rotor to turn freely about its own axis. As in other magnetic-bearing systems, the rotor is the only moving part, and the

absence of mechanical contact between the rotor and the stator assures long life. The adjustable magnetic bearing would be particularly useful in high-speed rotating devices, robotic joints, and supports for optical elements.

The bearing (see Figure 1) includes a

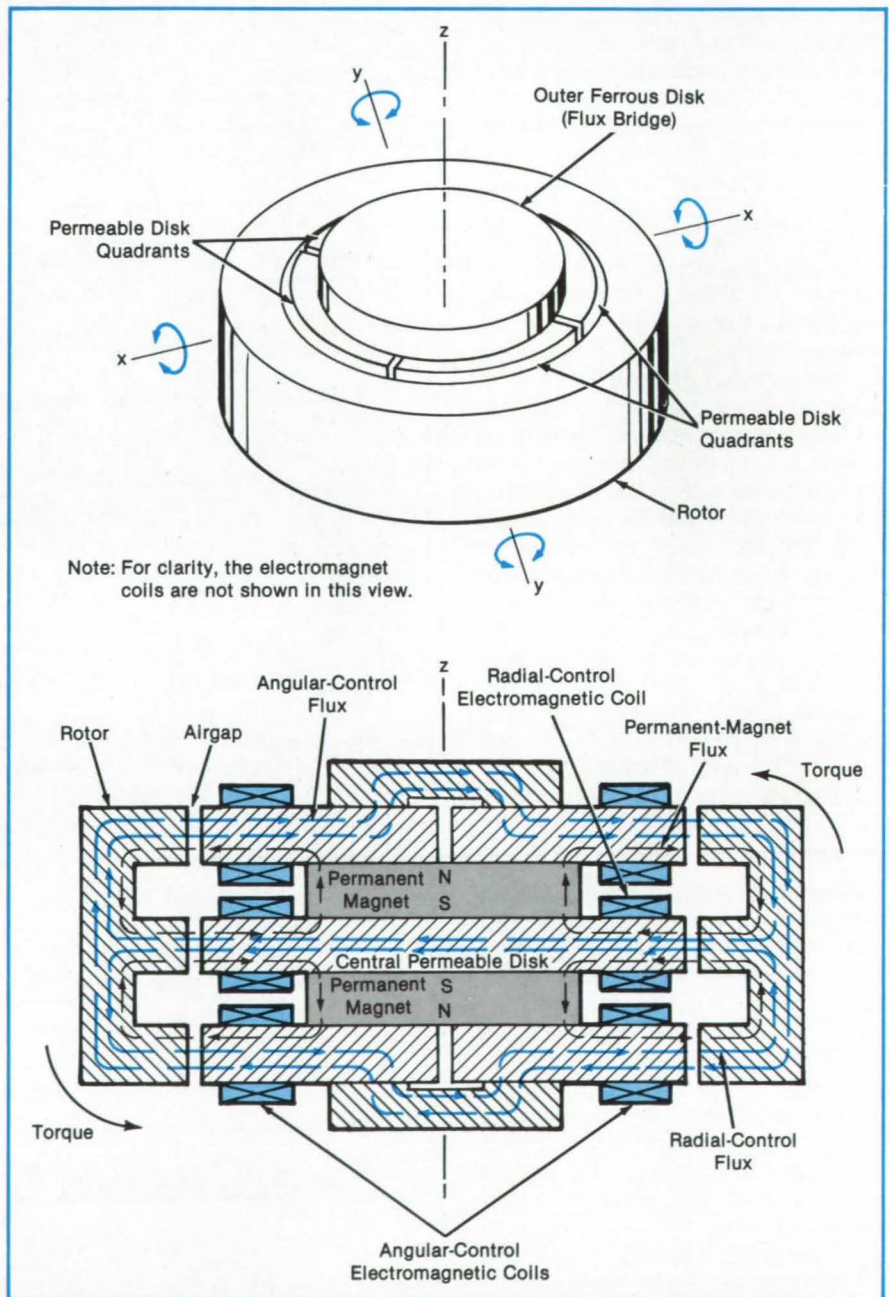

Figure 1. The **Active Magnetic Bearing** includes electromagnet coils that tilt the rotor clockwise or counterclockwise, or move it right or left.

stator equipped with permanent magnets and electromagnet coils. The rotor has a magnetically permeable ring that surrounds the stator. Three inwardly projecting rims on the rotor constitute magnetic pole pieces and face similar pole pieces on the stator.

The radial-control electromagnet coils on the opposite sides of the central permeable disk introduce a magnetic flux along the x axis (toward the left in the case of the figure). This flux aids the permanent-magnet flux on the right side while opposing it on the left side. Thus, the magnetic attraction between the rotor and stator pole pieces increases on the right and decreases on the left, thereby tending to pull the rotor to the left. Similarly, reversing the current in the radial-control coils forces the rotor to the right.

The angular-control electromagnet coils on the upper and lower permeable disk quadrants are connected to produce a magnetic flux circulating around the periphery of the magnetic path. When this flux circulates in the clockwise direction, as in the figure, it aids the permanent-magnet flux at the upper-right and lower-left airgaps and opposes the permanent-magnet flux in the lower-right and upper-left airgaps. This flux pattern does not introduce a net right or left force, but the inequalities of forces at the corner airgaps produce a net torque on the rotor, tilting it counterclockwise about the y axis. Of course, the rotor could be tilted clockwise by reversing the angular-control flux.

Similar electromagnet coils are placed in the y-z plane of the stator to control the rotor motion along the y axis and the rotor tilt about the x axis. No electromagnetic control is needed to steady the rotor along the z axis. The rotor continually seeks the z-axis position of minimum magnetic reluctance to the permanent-magnet field; because of the rotor and stator symmetries, this position is independent of the angular position of the rotor.

Figure 2 illustrates a feedback control system for one plane of the bearing. The control circuitry varies the currents in the radial- and angular-control coils in re-

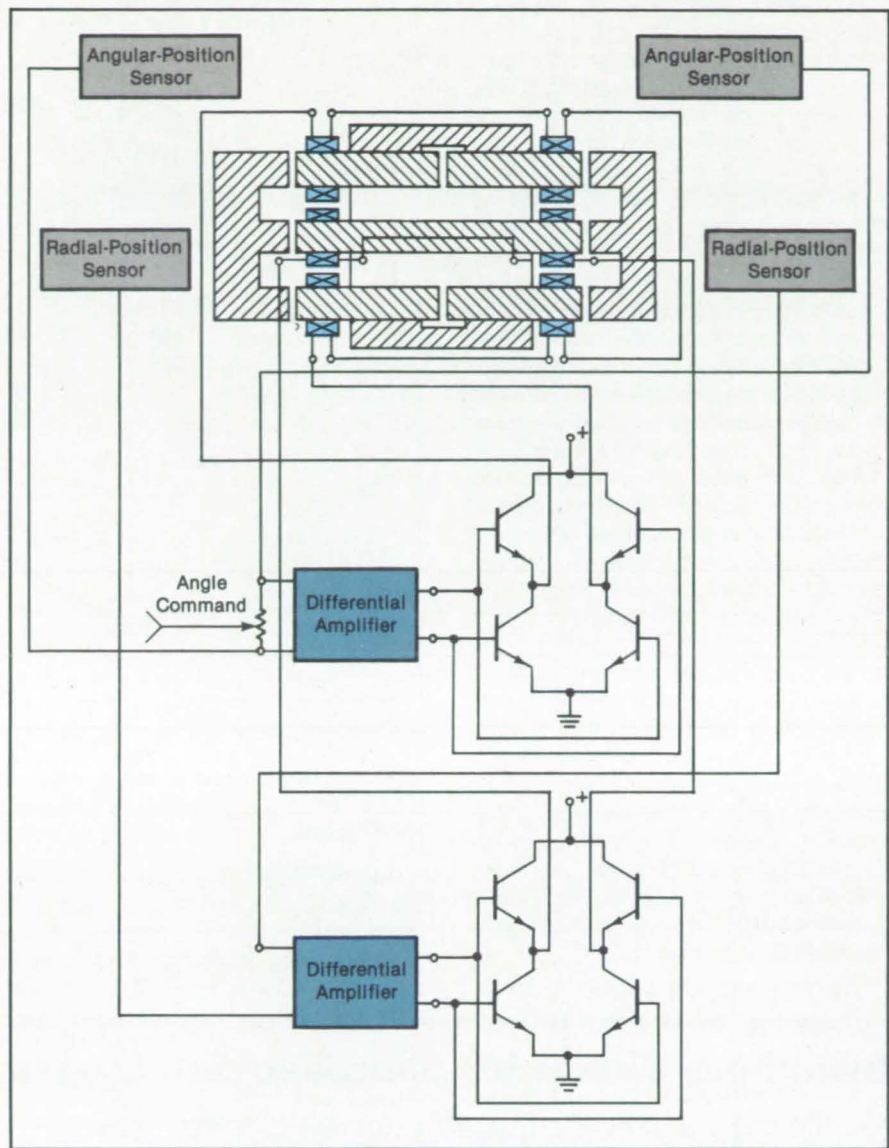

Figure 2. A **Feedback Control System** maintains the rotor at equilibrium radial and angular positions in response to signals from position sensors. No active control is needed to maintain the equilibrium axial position.

sponse to the outputs of the radial- and angular-position sensors. An angular-command bias to the angular differential amplifier sets the equilibrium angular position. In principle, a similar arrangement could be used to set an equilibrium radial position different from the z axis.

This work was done by Philip A. Studer of **Goddard Space Flight Center**. For

further information, Circle 48 on the TSP Request Card.

This invention is owned by NASA, and a patent application has been filed. Inquiries concerning nonexclusive or exclusive license for its commercial development should be addressed to the Patent Counsel, Goddard Space Flight Center [see page 19]. Refer to GSC-12957.

Three-Axis Attitude Control With a Single Wheel

Internally gimballed wheel plus reaction torquing combine to yield three-axis control.

Goddard Space Flight Center, Greenbelt, Maryland

A single-device attitude-control system provides stabilization along three axes. Conventionally, some combination of devices has been used for multiaxis control.

NASA Tech Briefs, March 1987

For example, a system might include three low-speed reaction wheels, one for each axis, or two control-moment gyros, each of which can control two axes. These multiple

device systems can be replaced by a multi-function device with a single moving element, having lower mass and potentially higher reliability.

The new system includes a flywheel driven by an electronically-commutated dc motor and supported by a torque-producing active magnetic bearing (see figure). This arrangement allows both the free rotation of the motor and flywheel about the central axis and limited angular torsional deflections of the flywheel about two orthogonal axes perpendicular to the central axis.

The bearing is a radially-servoed, permanent-magnet device that can produce cross-axis torques on the flywheel. The operation of the bearing, including the production of cross-axis torques, is described in "Magnetic Bearing With Radial and Angular Control," (GSC-12957) in this issue of *NASA Tech Briefs*. Three body-attitude sensors (for pitch, yaw, and roll) generate command signals along three orthogonal axes (x, y, and z, respectively). The signals energize coils that produce torques and the consequent limited angular excursions about the x and y axes, and control the speed of the flywheel about the z axis.

The flywheel turns at high speed of about 1,000 rad/s so that it can develop high gyroscopic torques with limited angular excursions. An energy-recovery system operates during the deceleration of the motor. This regenerative braking system makes high rotational speed practical. Without it, too much energy would be lost when the flywheel must be decelerated in response to control signals.

This work was done by Phillip A. Studer

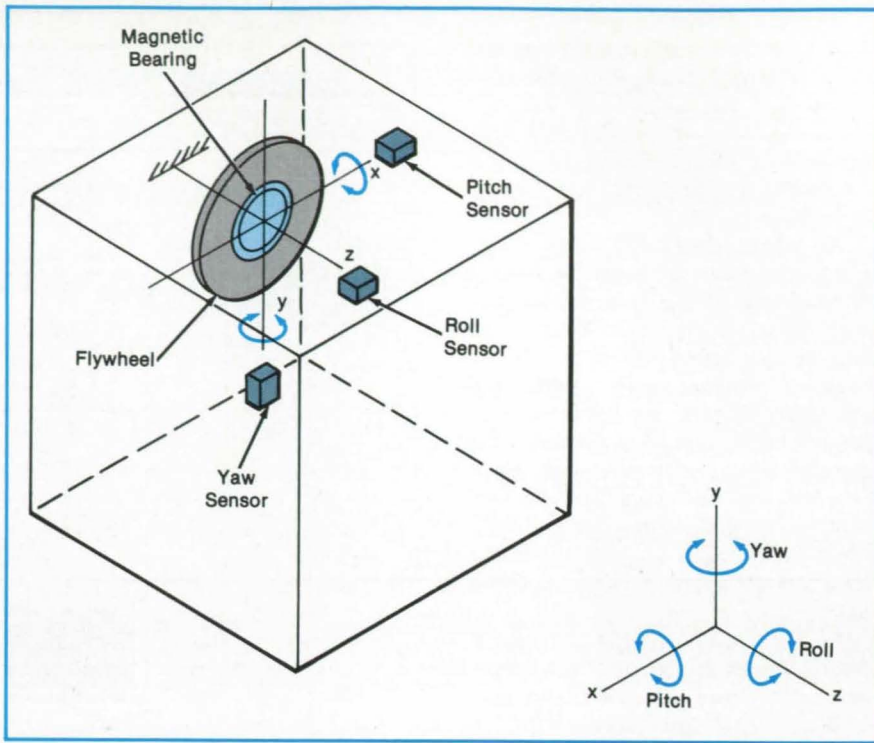

A Flywheel Connected to an Electronically Controlled Motor rotates on a magnetic bearing. At high rotational speed, small angular displacements about the x and y axes (in response to control signals) enable the storage of relatively large amounts of angular momentum. Angular momentum about the z axis is stored in changes in the rotational speed.

of **Goddard Space Flight Center**. For further information, Circle 47 on the TSP Request Card.

This invention is owned by NASA, and a patent application has been filed. Inquiries

concerning nonexclusive or exclusive license for its commercial development should be addressed to the Patent Counsel, Goddard Space Flight Center [see page 19]. Refer to GSC-12970.

Switching Circuit for Shop Vacuum System

No internal connections to machine tools are required.

Marshall Space Flight Center, Alabama

A switching circuit controls a vacuum system that draws debris from grinders and sanders in a machine shop. The cir-

cuit automatically turns on the vacuum system whenever at least one sander or grinder is operating. Thus, debris are

safely removed, even when the operator neglects to turn on the vacuum system manually.

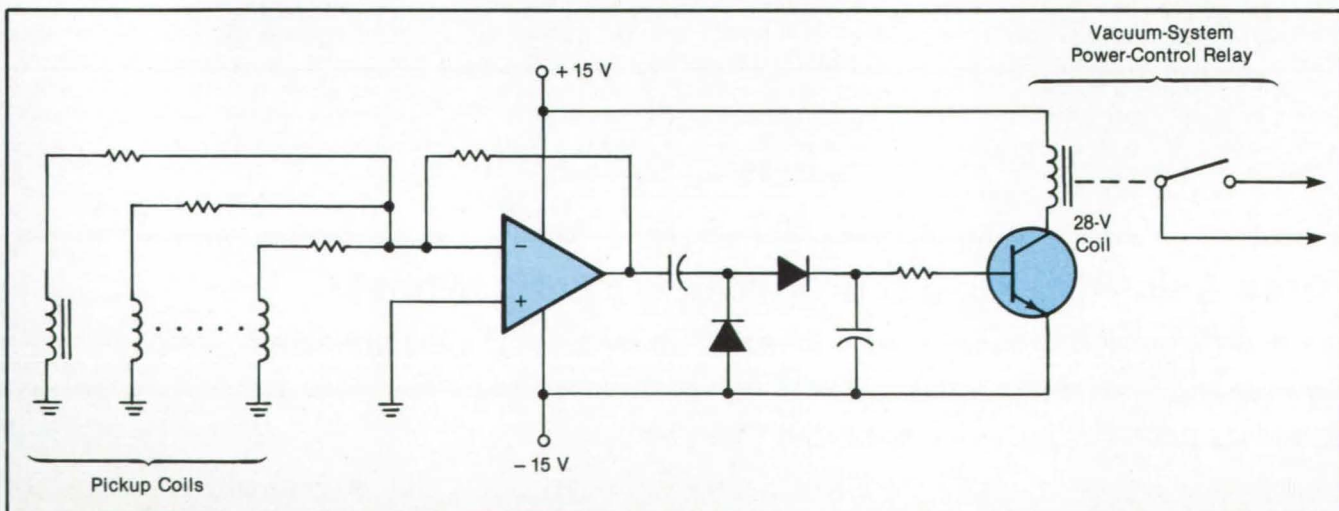

The **Pickup Coils Sense the Alternating Magnetic Fields** just outside the operating machines. A signal from any coil or combination of coils causes the vacuum system to be turned on.

The circuit was devised for a shop in which different sanders and grinders operate at different voltages. The installation of a conventional control for an automatic vacuum system would be expensive because of the complexity of the equipment needed to accommodate the different voltages.

The switching circuit is simple, inexpensive, and easy to install. No internal electrical or mechanical connection has to be made to any of the shop machinery other than the vacuum system. A small inductor is glued to the outside of the motor housing of each machine to pick up the small alternating magnetic field transmitted through the housing during operation.

The coil output is amplified 10^4 times, rectified, filtered, and applied to the base of a switching transistor (see figure). The transistor controls the current to the vacuum-system power relay. Since the pickup coils are wired in parallel, the system switches on whenever at least one of them puts out an "on" signal. (To assure reliable operation with any combination of one or more machines operating, it may be necessary to orient all coils for the same polarity.)

This work was done by Richard K. Burley of Rockwell International Corp. for Marshall Space Flight Center. No further documentation is available.
MFS-29153

Books and Reports

These reports, studies, and handbooks are available from NASA as Technical Support Packages (TSP's) when a Request Card number is cited; otherwise they are available from the National Technical Information Service.

Characteristics and Applications of Metal Hydrides

Terrestrial applications in the future could improve the storage of hydrogen and the pumping of heat.

A report discusses the engineering principles of the uses of metal hydrides in spacecraft. Metal hydrides can absorb, store, pump, compress, and expand hydrogen gas. In addition, metal hydrides release or absorb sizeable amounts of heat as they form and decompose — a property that can be adapted for thermal-energy management or for propulsion. Candidate materials include LaNi_5H_6 , FeTiH_2 , MgH_2 , LiH , CaH_2 , UH_3 , and VH_2 .

NASA Tech Briefs, March 1987

Do you know that Valcor makes all these fluid control products?



1 SELF-DISPLACING
HYDRAULIC
ACCUMULATORS



2 PRESSURE REGULATORS
& RELIEF VALVES



3 SOLENOID &
PRESSURE OPERATED
FUEL VALVES

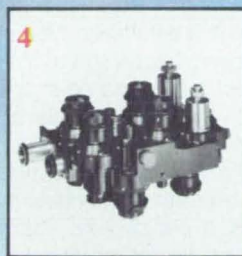

4 PRESSURIZATION
SYSTEMS



5 MODULATING
VALVES



6 HOT GAS
SOLENOID VALVES

These aircraft companies do.

1. Northrop/McDonnell (F-18) • Grumman (X-29 FSW)
Boeing (AWACS E-34) • Lockheed (S3A & C5A)
2. Fairchild (F-27 & FH-227) • North American Rockwell (F-86)
McDonnell Douglas (F-4E) • Hughes Research • NASA Programs
3. Multiple Programs for:
Boeing • United Technologies • Rockwell • Northrop • Airesearch
McDonnell Douglas • Grumman • Fairchild Republic • Lockheed
Woodward Governor • Saab • Allison • Sundstrand • Beech • Cessna
4. General Dynamics (C-131) • Lockheed (C5A)
Boeing (B-52, KC135, B-707, B-727, B-737, B-747)
5. Grumman (X-29 FSW & A6) • Electronic Fuel Controls Mfrs.
6. Fairchild (SF-240) • Bell Helicopters • Rockwell (A10) • GM

Get to know us better. Contact our Aerospace Applications Department for your copy of Valcor's Military/Aerospace Product Catalog.



VALCOR ENGINEERING CORPORATION

2 Lawrence Road, Springfield, New Jersey 07081
(201) 467-8400 TWX: 710-996-5976

The report describes efforts to do the following:

- Identify heat sources and sinks suitable for driving metal hydride thermal cycles in spacecraft;
- Develop concepts for hydride subsystems employing the available heating and cooling methods; and
- Produce a data base on the estimated sizes, masses, and performances of hydride devices for spacecraft.

Two possible applications proved to be particularly promising. Thermally powered hydride heat pumps weigh much less than conventional vapor-compression heat pumps when the mass penalties for pumping power are considered. For the storage of hydrogen, hydride devices are the lightest alternatives when the hydrogen-storage times of cryogenic containers are insufficient.

The report discusses the physical chemistry of metal hydrides, how they can be contained, and how the performances of hydride devices can be estimated. Six applications are described (unattractive applications are not included). For each application, the mass, volume, and power requirements are estimated for subsystems based on currently available technology. In addition, estimates are developed for subsystems incorporating anticipated improvements in technology.

An appendix explains a computer model that predicts the behavior of a hydride bed in a variety of applications. Other appendixes describe the hydride container on which many of the estimates were based, list some of the physical and thermodynamic properties of the major classes of metal hydrides, and discuss safety concerns.

This work was done by Gregory J. Egan and Franklin E. Lynch of Hydrogen Consultants, Inc., for Marshall Space Flight Center. To obtain a copy of the report, "Investigation of Metal Hydrides for Integration of Spacecraft Hydrogen Sources," Circle 149 on the TSP Request Card.
MFS-26028

Residential Photovoltaic/Thermal Energy System

A proposed system would supply a house with both heat and electricity.

A pair of reports describes a concept for a self-sufficient heating, cooling, and power-generating system for a house. Panels on the walls of the house would provide hot water, space heating, and heat to charge a heat-storage system,

and would generate electricity for circulation pumps and fans. Roof panels would generate electricity for the household, operate a heat pump for summer cooling, and provide supplementary winter heating via the heat pump, using the solar-cell cooling-fluid loop.

The wall panel includes a pair of glass sheets with an airspace between them and tiltable solar-cell boards on the outside. Banks of louvers between the glass sheets are rotatable like venetian blinds to expose an appropriate surface to the outside; a silvered side to reflect heat rays in summer and an oxidized copper side to absorb them in winter. In the heating season, a fan circulates room air over the louvers to extract their heat.

The exterior solar-cell boards are mounted at gaps between the louver banks so as not to cast shadows on them. The boards are tilted at an angle that changes with the season so that the boards face the Sun squarely and absorb a maximum of available light. In winter or summer, water for domestic use is pumped through a thin finned tube in the airspace to absorb heat. Vents at the tops and bottoms of the panels open the airspaces to the inside or outside of the house, depending on the season.

The roof panel includes asymmetric V-trough concentrators and photovoltaic strip modules. A photovoltaic strip runs along a tube at the bottom of a trough. Water or another coolant flowing at the base of a strip absorbs heat generated by the photovoltaic cells as they produce electricity. The householder would reverse the north/south orientation of the trough on the first days of spring and fall to ensure the maximum capture of sunlight.

The wall and roof panels can be used independently. A homeowner could elect to install wall panels only, roof panels only, or both wall and roof panels.

This work was done by M. Kudret Selcuk of Caltech for NASA's Jet Propulsion Laboratory. To obtain copies of the reports, "A Combined Photovoltaic-Thermal Energy System for Residential Applications" and "Analysis and Two Years of Testing of the Vee-Trough Concentrator/Evacuated Tube Solar Collector," Circle 42 on the TSP Request Card.
NPO-15013

Position Control for Non-linear, Multiple-Link Robots

Several approaches to a complicated control problem are examined.

A report surveys methods for controlling the motion of robot manipulators. The report applies to coupled, highly nonlinear

multiple-link robots.

The report notes that the position control of a robot involves the calculation of control inputs to the robot motors so that the response of the robot arm will be stable, the robot position will not deviate from the desired value even in the presence of disturbance inputs, and the robot arm will be able to follow desired trajectories with no errors. It is relatively easy to accomplish these objectives with linear, time-invariant systems.

However, a multiple-link robot is neither linear nor time-invariant because each link in the robot arm exerts varying torques on the other links as the configuration of the arm changes. The dynamic equations for a multiple-link manipulator are therefore highly nonlinear and coupled, and controlling such a manipulator is a very complicated task.

The report begins with an analysis of linear control for a single-link manipulator. It shows that the linear control methods can be applied to multiple-link manipulators with independent linear-position servos operating simultaneously at all the joints, because such systems can be approximated with linear systems once the nonlinearities due to the dynamic interactions among joints are taken into account.

In one control strategy, nonlinear state feedback is used to reduce the control of a robot system to a linear problem. For example, in the computed-torque technique, the coupling inertias, centrifugal torques, and Coriolis torques exerted by each link on the others are predicted, and the control of each link is then adjusted to compensate for them. An analogous method that provides position control of the last manipulator link only is called the "resolved-acceleration-control" technique.

The acceleration-feedback-control technique relies on high-gain feedback to minimize the effect of nonlinearities. A technique called "robust nonlinear control" is based on an inversion algorithm for the input/output map of a nonlinear system. It provides for close tracking of a required trajectory despite uncertainty in the payload.

The report ends by presenting an adaptive control technique based on a discrete linear model of the robot arm, obtained by linearizing the nonlinear dynamical equations about a nominal trajectory. The parameters of the model are calculated with an adaptive parameter-identification algorithm. Based on the system model, an optimal control input is computed using position and velocity feedback.

This work was done by Homayoun Seraji and Mary M. Moya of Sandia National Laboratories for NASA's Jet Propulsion Laboratory. To obtain a copy of the report, "Robot Control Systems: a Survey," Circle 119 on the TSP Request Card.
NPO-16806



THE CHOICE for Software Engineering

Vitro assures the best value for your program by providing innovative technical and management approaches at a reasonable cost. These features have made us the choice since 1948.

Technical

- Structured Methodology
- Innovative Approaches
- Experienced
- Reliability

Management

- Responsive
- Project Control
- Quality Assurance
- Management Tools

Cost

- On Schedule
- On Budget
- Efficient
- Actual Cost Tracking

Vitro, the choice again and again. We stand ready to deliver for you. Ask us how we can meet your needs. Call our Business Development Office at (301) 231-1300 or write: Vitro Corporation, 14000 Georgia Avenue, Silver Spring, MD 20906-2972.

Systems Engineering

Software Engineering



The Art of Management / The Science of Engineering

A Unit of the Penn Central Federal Systems Company

Circle Reader Action No. 394

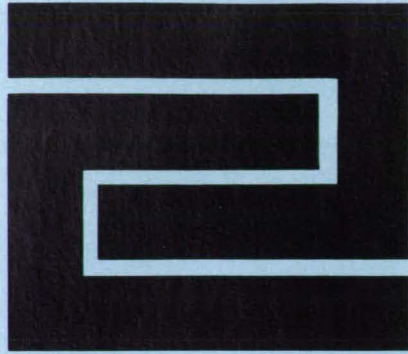

Hardware, Techniques, and Processes

- 68 Optical Welding Torch
- 69 Elastic Hinge for Solar-Cell Array
- 70 Molded Concrete Center Mine Wall
- 70 Pultrusion Fabrication of Long Boom Models
- 71 Making Ceramic Parts by Laminating and Sintering Thin Sheets
- 72 Deep, Precise Etching in Semiconductors

Optical Welding Torch

Arc welds can be viewed along the torch axis.

Marshall Space Flight Center, Alabama

A gas/tungsten-arc welding torch supports an electrode at its center while enabling the viewing of the weld area along the torch axis. The gas torch accommodates a lens and optical fibers — all part of a vision system for a welding robot.

The main component of the torch is the optical body — a square-cross-section copper part with internal bores that accept

the various optical and welding components (see figure). A symmetrical spoked structure is machined in the optical body in its lower portion.

The optical body includes openings for coaxial viewing and support, electrical contact, and heat removal from the electrode, which is held by a collet screwed into the hub of the spoked structure.

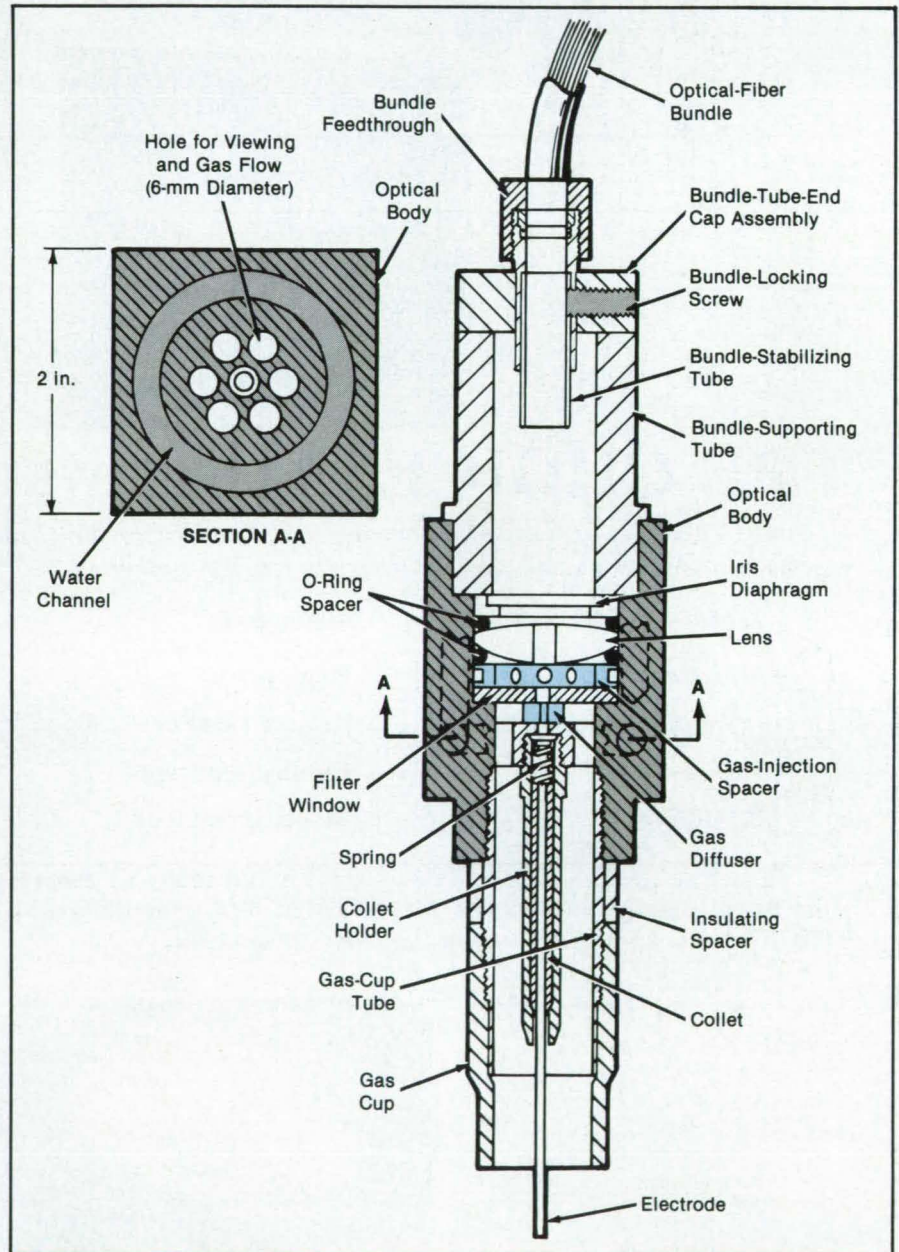

The **Welding Torch** includes a spoked structure in the central bore of the optical body. The structure supports the welding electrode, carries electric current to it, and takes heat away from it. The spokes are formed by drilling six holes 60° apart around the center line of the torch.

Channels for cooling water are drilled through the optical body, close to the outer ends of the spokes. Cooling water enters through a vertical channel at a corner of the body and flows out through a channel at the opposite corner.

A lens above the spokes focuses a reduced image of the weld area, which is one-half to three-quarters of an inch (1.3 to 1.9 centimeters) in diameter, onto the 5-millimeter-diameter end face of an optical-fiber bundle. The bundle is held by a brass supporting tube that sits in a bore at the top of the optical body. The tube also secures a stack of components: an iris diaphragm, the lens, a gas-injection spacer, and a filter window. A bundle-feedthrough nut atop the support tube can be loosened so that the bundle can be slipped up and down for focusing.

A copper gas-cup tube screws into the bottom of the optical body, and a ceramic gas cup screws into the gas-cup tube. The tube holds the cup on the center line of the

torch and guides the flow of shielding gas to the cup. The tube can readily be removed and replaced if it is damaged.

The electrode is damped by a collet, which is mounted in a collet holder. The collet allows the electrode to be adjusted, removed, and replaced conveniently. The collet holder must be tightened firmly against the torch body for good thermal contact and accurate alignment of the collet with the optical axis. A spring in the holder produces a downward thrust on the collet. The chamfered outer end of the collet seats against the chamfered inner end of the holder, forcing the collet inward to grip the electrode.

Shielding gas enters the optical body through a channel parallel to the cooling-water channels and passes through a gas-injection spacer in the bore. The spacer guides the flow smoothly around the periphery of the bore. The gas flows inward through radial holes in the spacer, then down through a central hole in the

filter window (which stops unwanted light wavelengths from entering the vision system). Finally, the gas flows through a diffuser (which helps to prevent turbulence and entrainment of air at the weld site), through the holes in the spoked structure, and into the gas cup.

This work was done by Richard W. Richardson of Ohio State University for Marshall Space Flight Center. For further information, Circle 70 on the TSP Request Card.

In accordance with Public Law 96-517, the contractor has elected to retain title to this invention. Inquiries concerning rights for its commercial use should be addressed to

*Richard W. Richardson
Ohio State University
1314 Kinnear Road
Columbus, OH 43212*

Refer to MFS-26034, volume and number of this NASA Tech Briefs issue, and the page number.

Elastic Hinge for Solar-Cell Array

A lightweight, compact hinge provides part of its own closing torque.

Marshall Space Flight Center, Alabama

An elastic hinge folds to a small thickness, allows easy replacement of the panels attached to it, and provides part of the torque for refolding without additional springs. The hinge is being developed for foldable modules for solar-cell panels.

Fourteen modules, each 9.5 by 14.6 in. (24.1 by 37.1 cm), are attached to a row of hinges 12 ft (3.66 m) long on hinge-stiffener strips. The hinge allows opposing pairs of modules (see figure) to fold together so that the assembly is no more than 0.052 in. (1.32 mm) thick.

The hinge is assembled by inserting the loops of the lower hinge elements through slots in the hinge stiffeners and slots in the upper hinge elements. A pin inserted through the hinge loops captures the stiffeners and the hinge elements.

When the panels are unfolded for use, one panel wing must travel through an arc of 180° relative to the other panel wing. This is done by bending opposing hinge elements through 90° each. The panel wings are then held in tension in the open position. When the panels are to be refolded, the hinge, with its residual elasticity, helps in turning the panels toward each other.

The hinge elements are made of molybdenum foil. This material was selected for its stiffness, and because its coefficient of thermal expansion closely matches that of the glass modules.

This work was done by Richard M. Mills of Lockheed Missiles and Space Co., Inc., for Marshall Space Flight Center. For further information, Circle 64 on the TSP Request Card.

Inquiries concerning rights for the commercial use of this invention should be addressed to the Patent Counsel, Marshall Space Flight Center [see page 19]. Refer to MFS-28133.

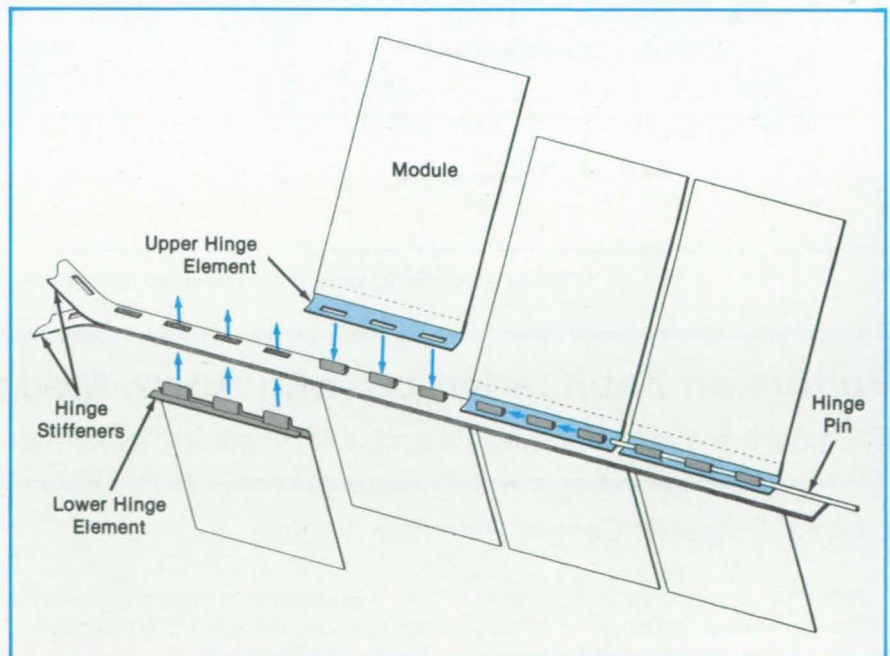

The **Elastic Hinge Holds Modules** of a solar-cell array. The modules are kept in the open position shown here by an external restraint (not shown). When the restraint is removed, the elasticity of the molybdenum hinge elements helps to fold the facing modules together.

Molded Concrete Center Mine Wall

An extruded structure would provide ventilation and roof support.

NASA's Jet Propulsion Laboratory, Pasadena, California

A proposed semiautomatic system would form a concrete-foam wall along the middle of a coal-mine passage. The wall would help support the roof and would divide the passage into the two conduits needed for the ventilation of the coal face.

The conceptual system (see figure) is mounted on a maneuverable, self-propelled pair of vehicles. The rear vehicle straddles the section of wall under construction and carries a mobile form in which the section of wall is to be molded.

A set of hydraulic cylinders adjusts the form height to the roof height at different locations. To accommodate local roughness and curvature, inflated tubes at the top and bottom of the form serve as compliant extensions that seal the form to the floor and the roof.

A web of glass-fiber roving is applied to the inner surface of the form on each side, in effect forming a mold lining. Concrete foam is pumped from a portable concrete-mixing-and-foaming unit into the form in the space between the webs.

The webs increase the surface strength of the wall and act as a mold release. Thus, when the concrete has hardened, the vehicles can simply move forward to mold the adjoining section of wall; it is not necessary to flush the form.

This work was done by Edward V. Lewis of Caltech for NASA's Jet Propulsion Laboratory. For further information, Circle 36 on the TSP Request Card. NPO-16195

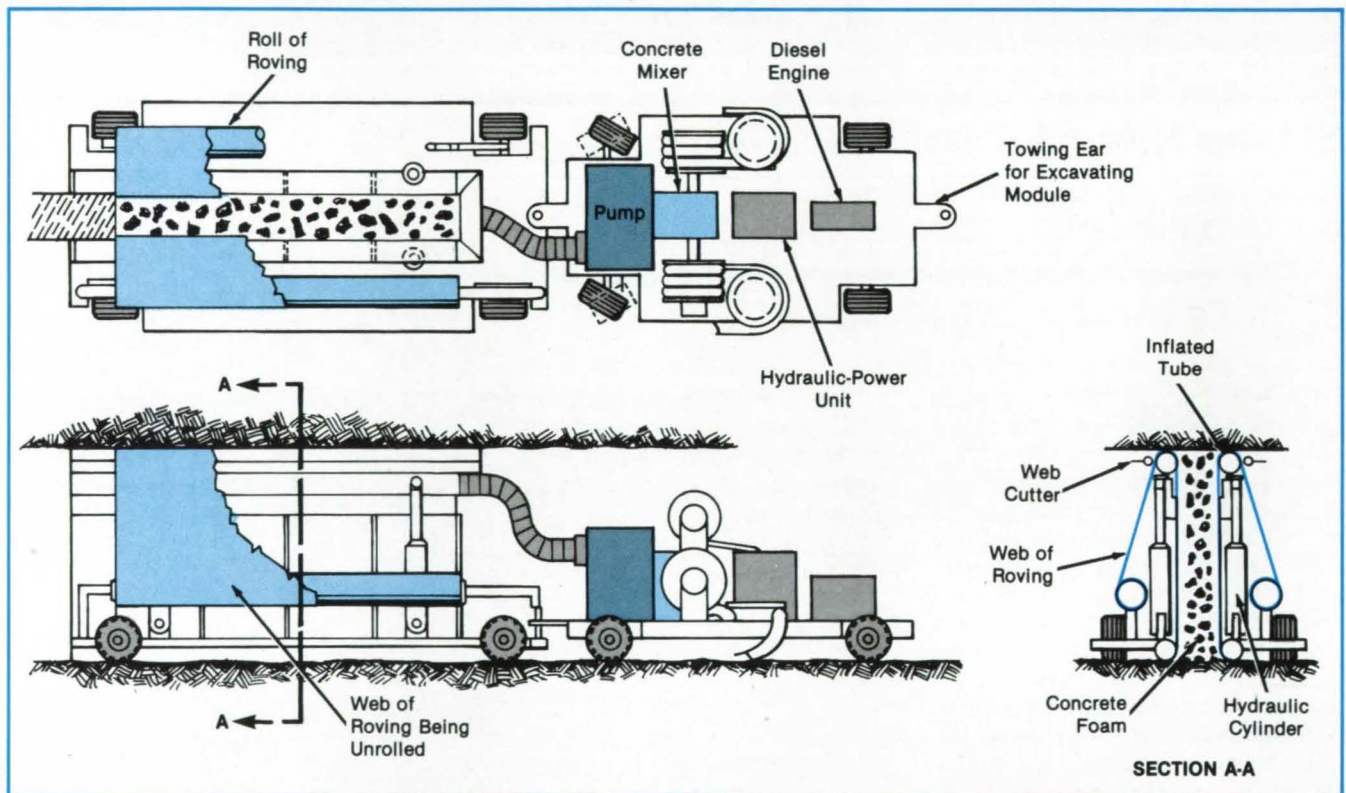

A Mobile Mold and Concrete-Foam Generator form sections of wall in place.

Pultrusion Fabrication of Long Boom Models

Composite materials of quasi-isotropic strength are obtained.

Langley Research Center, Hampton, Virginia

Pultrusion is a composite-fabrication method by which an extremely long fiber-reinforced polymer matrix material can be produced by pulling the fiber through a resin system for impregnation and then through a heated curing die. As the fiber/resin bundle travels through the curing

die, polymerization occurs, and a composite structure emerges from the exit end of the die (see figure).

While pultrusion is not a new process, it is still in its infancy in the aerospace industry. At Langley Research Center, experiments with pultrusion are being con-

ducted in advanced-composites technology with applications to aeronautical and space structures. In one such program, long flexible beams were required to establish ground vibration-test methods for very-low-frequency structures. The beams were fabricated by the pultrusion process

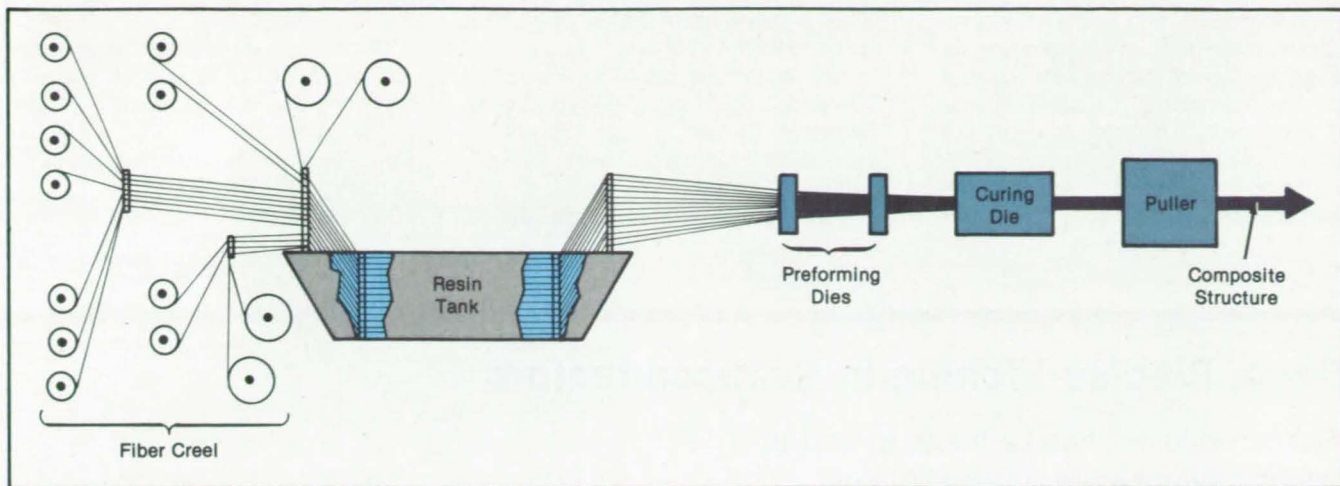

The **Fiber-Reinforced Polymer Matrix Material** is produced by pulling the fibers through the polymer resin system and then through preforming dies and a heated curing die.

using fiberglass for reinforcement and a thermoset polyester resin system for the matrix. These beams were rectangular in cross section [0.25 by 4.00 in. (0.64 by 10.16 cm)] and 32.81 ft (10.00 m) in length, each weighing 25.6 lb (11.6 kg).

The research applications of such tests are model space booms for the proposed MAST program and the space station. Because of the potential for lower cost, higher specific-strength and flexural properties, and dynamic-similarity considerations, pultruded-composite-beam models were selected as an option over extruded-aluminum structures. Continuous lengths up to 270 ft (82.3 m) were pultruded and later cut to the required lengths for dynamic testing.

The composite-reinforcement-materials

approach used in the beam models was unique in that equal strength is provided in both the longitudinal (0°) and transverse (90°) directions. This was achieved by selective fiber orientation using knit-locked fabric. The availability of this new type of fabric makes possible the pultrusion fabrication of composite materials of quasi-isotropic strength using the conventional "wet-resin" technique. Furthermore, the potential for the precise orientation of fibers in any desired direction in pultrusion can now be realized by this approach to reinforcement materials.

Ultrasonic C-scans as well as SEM evaluations showed good wetting of fibers and bonding between plies. Physical and mechanical test results were compared with those of fiberglass unidirectional

roving and continuous-strand-mat, conventional pultrusions, and with extruded 6061-T6 aluminum alloy.

This is an advancement in the state of the art of pultrusion technology in that the ability to duplicate any hand-layup fiber orientation, e.g., (0°, +45°, -45°, 90°)_S, and still use the "wet-resin" method of impregnation is now possible. This concept is not restricted to the fiberglass-reinforcement and polyester-matrix systems used in this program and should prove adaptable to other fiber/resin systems.

This work was done by Maywood L. Wilson and Robert Miserentino of Langley Research Center. For further information, Circle 57 on the TSP Request Card. LAR-13441

Making Ceramic Parts by Laminating and Sintering Thin Sheets

The chemical composition can be varied as a function of depth.

Lewis Research Center, Cleveland, Ohio

A technique has been developed to fabricate a monolithic ceramic component by sintering a laminated body made from thin sheets of green ceramic. This method allows discrete changes in chemistry to be effected across the monolith. A component that has a one-dimensional variation in material composition could be fabricated in this manner.

The thin sheets of ceramic can be made by "tape casting," in which a powder of the NASA Tech Briefs, March 1987

desired composition is placed in suspension and spread onto a hot surface. The liquid is evaporated, leaving a thin sheet of green ceramic. The sheet may be given flexibility through the incorporation of polymers (plasticizers) dissolved in the suspending liquid. Since the sheets are fabricated independently, the composition of any one sheet is independent of that of the others.

To construct the final part, the thin

sheets are stacked in the appropriate order of desired chemical properties, compressed into a monolith, and sintered. Proof-of-concept tests have demonstrated that such parts can be made without bloating or delamination of the ceramic.

An example of the type of part that could be fabricated from this technique is an all-ceramic turbine-shroud seal for an advanced gas-turbine engine. The hot face of the seal could be made of material with

good thermal-cycling and high-temperature characteristics, whereas the cold side could be made of material with high structural strength and high fracture toughness. One combination of materials would be (a) yttria/partially stabilized-zirconia (Y/PSZ) for the layers closest to the hot face of the turbine shroud seal and (b) magne-

sium/partially stabilized-zirconia (M/PSZ) for the "structural" layers.

This work was done by James D. Cawley of Ohio State University for Lewis Research Center. Further information may be found in NASA TM-87078 [N85-32333/NSP], "Tape Casting as an Approach to an All-Ceramic Turbine Shroud

Seal."

Copies may be purchased [prepayment required] from the National Technical Information Service, Springfield, Virginia 22161, Telephone No. (703) 487-4650. Rush orders may be placed for an extra fee by calling (800) 336-4700. LEW-14361

Deep, Precise Etching in Semiconductors

Semiconductors can be made to accept precise etching after pretreatment.

NASA's Jet Propulsion Laboratory, Pasadena, California

A combination of material destabilization and anisotropic etching permits the formation of precise perpendicular-wall cavities in silicon wafers and other semiconductors. This new technique extends

the capabilities of current micromachining technology to the fabrication of submillimeter waveguide arrays and filters.

"Micromachining" refers here to the fabrication of micromechanical devices,

such as pressure sensors, bolometers, and switches, on silicon crystal wafers by combining the processes of VLSI (very-large-scale integration) technology (doping, masking, epitaxial deposition, oxi-

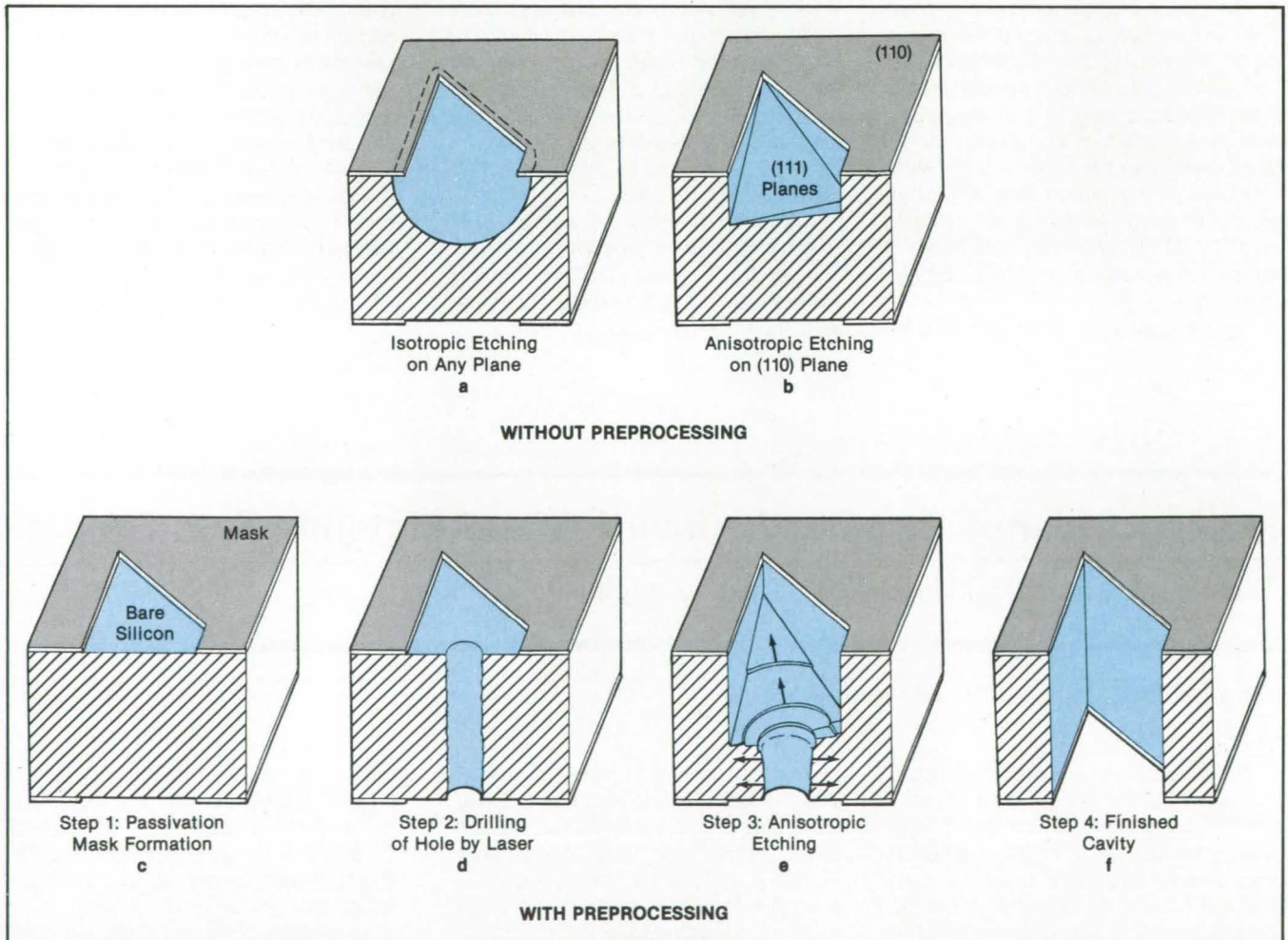

Anisotropic Etching of a Hole in a masked (110) silicon wafer yields a cavity of arbitrary depth bounded by perpendicular (111) planes. In contrast, conventional anisotropic etching produces a shallow, faceted cavity, and isotropic etching creates a hemispherical cavity.

CHIPS TO GO.



If you're hungry for some of the new MIL-STD-1750A chips, we've got them.

Fact is, we can serve 'em up right now. Full MIL temperature range, low power, high speed. No waiting. Our MDC281 is the first microprocessor chipset to gain MIL-STD-1750A (Notice I) verification.

It's a general-purpose, 16-bit module consisting of three CMOS/SOS Large Scale Integrated Circuits on a single plug-in assembly.

The MDC281 is ideal for embedded applications in small systems where there are size, weight and power limits. It performs across the full MIL temperature range (-55°C to $+125^{\circ}\text{C}$) on less than two watts, and is available in several speed and screening grades. If you need MIL-STD-1750A chips, call (314) 234-8040. Or write: McDonnell Douglas Microelectronics Center, Marketing, M002/111, P.O. Box 516, St. Louis, MO 63116.

We serve orders to go.

MCDONNELL DOUGLAS

Circle Reader Action No. 374

**VSW
certified by
SEAFAC**

HEISE®

A QUARTZ GAUGE/ CONTROLLER GOOD ENOUGH TO BE NAMED HEISE®

Before a product can be named Heise, it must measure up to an exacting set of standards that Heise customers have come to expect.

Each product must be flexible enough to indicate, individually or collectively, absolute, differential, vacuum or gauge pressures and do so with unimpeachable accuracy.

The new Heise Series 10, is just such a product.

The three models within the Series 10 deliver an accuracy of 0.01% of reading and comprise an extremely flexible package which can be configured to meet most any requirement for precision pressure instrumentation.

The Model PPG 149, the most basic configuration, is a precision pressure measurement system.

The Model PPG 159 couples precision measurement with a unique servo valve system to provide both precision measurement and control capability.

The top of the line model DPC 179, has measurement and control capability that is complimented with a remote computer control through the use of an on-board computer interface. This system can accept RS-232, IEEE-488, 6 digit BCD or 19 bit binary outputs.

All Series 10 models allow interchanging of pressure ranges as well as angular or direct pressure readout. Designed as a flexible system, any model can be used for differential, gauge, absolute and vacuum measurements — with a simple turn of a dial. Pressure ranges of 0-5 through 0-600 psi, or equivalent, are available.

Servo valve equipped systems are capable of control pressures as low as 0.02 psi. Models PPG 149 and PPG 159 are upgradeable to more sophisticated models in the event your requirements change.

It wasn't easy incorporating all of these features into the Series 10 — but it's what our customers expect of Heise — precisely!

For a Heise representative, call 1-800-243-8160 or contact Dresser Industries, Inc., Box 515, Newtown, CT 06470, (203) 426-3115.

HEISE
PRECISION
PRESSURE
INSTRUMENTS

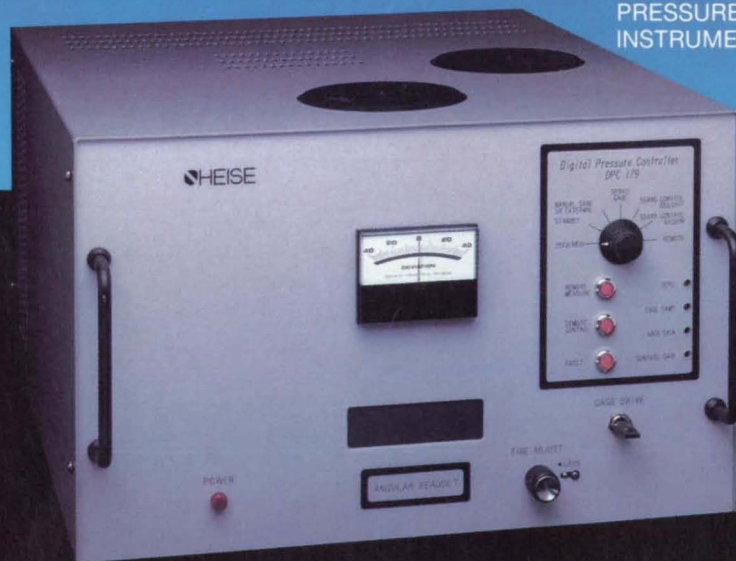

INSTRUMENT DIVISION, NEWTOWN, CONNECTICUT 06470

DRESSER INDUSTRIES DRESSER

dation, etc.) with anisotropic etching. Ordinary isotropic etchants attack all crystallographic planes indiscriminately, thereby forming hemispherical holes in masked wafers (see figure, a).

In contrast, anisotropic etchants of silicon crystals leave (111) planes unaffected but attack surfaces of any other orientation. Therefore, anisotropic etching ultimately produces cavities of atomically flat (111) planes bounded by concave edges (see figure, b). This permits the fabrication of precisely defined microscopic pyramidal cavities, slots, orifices, and similar mechanical elements.

This technology, however, does not permit the fabrication of perpendicular-walled deep holes, such as those needed for submillimeter waveguides, because of the early development of oblique (111) planes that stop the etchant from advancing deeper (see figure, b). In the new process, etching is preceded by the laser drilling of holes through the wafer (see figure, d). This insures that etch-sensitive convex edges will remain available for etchant attack until the perpendicular-walled rhombic cavity is etched completely through the wafer (see figure, f) or to a predetermined depth.

The pre-etching process of destabilizing the material to a given depth can be accomplished not only by laser drilling but also by any other process that renders the material unstable to the etchant. Alternatives include masking and etching from both sides so that the cavity bottom planes intersect each other, chemically milling or ion-etching central holes, or using an ion or laser beam to deform, recrystallize, or dope the central area of the desired cavity.

The pre-etching process is currently used to fabricate thin-walled arrays of submillimeter waveguides for use as dichroic bandpass filters. Other possible applications include the integration of sensor probes and processing of circuitry on the same silicon chip.

This work was done by Paul J. Shlichta of Caltech and Phillip W. Barth of Stanford University for NASA's Jet Propulsion Laboratory. For further information, Circle 49 on the TSP Request Card. NPO-16562

- Free Publicity
- Improved Public Relations
- Increased Sales

—All three are possible if we can describe how your company has used NASA technology to develop and improve its products.

For more information, call:
Linda Watts
(301) 621-0241
NASA Spinoffs

Data Shield®

Precision Glass Tape Reels

**What you see
is what you'll get**

Your tape. Your precious information.
Protected and clear as the reel
surrounding it.



Superior Data Protection

Data Shield precision glass tape reels have solid flanges. This design virtually eliminates dirt, electrostatic charge and normal physical-handling damage. Your tape life is increased and signal quality ensured because temperature and humidity changes are uniform, rather than concentrated at flange holes.

Greater Protection for Tape Edges

When your tape edges are better protected, so is the data you recorded. Data Shield's chemically strengthened Chemcor® glass flanges do not warp or permanently bend and cannot be dented.

When you need the best data protection, call (607) 974-4286 or write Corning Glass Works, Advanced Products, Main Plant 8-4, Corning, NY 14831.

CORNING

Circle Reader Action No. 454

Mathematics & Information Services

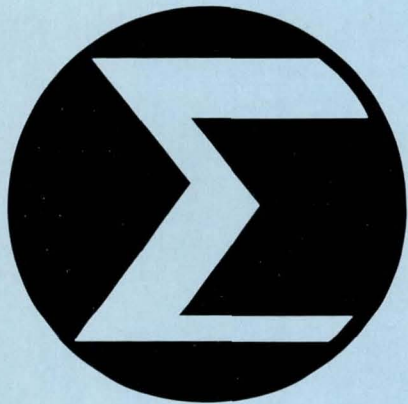

Hardware, Techniques, and Processes

76 Measuring Computer-Operator Workload

Books and Reports

77 Updated Conceptual Cost Estimating

77 Advanced Data Collection for Inventory Management

Measuring Computer-Operator Workload

Subjective and objective measurements are found to correlate and complement each other.

NASA's Jet Propulsion Laboratory, Pasadena, California

Two ways of measuring the workload of an operator in a large interactive computer system have been shown to be meaningful and easy to use. One method is based on operators' ratings of stress after subtasks in a continuous task. The other method is based on the workload ratio, W , which is the ratio of the time required for an operator to do a subtask to the time allowed for it.

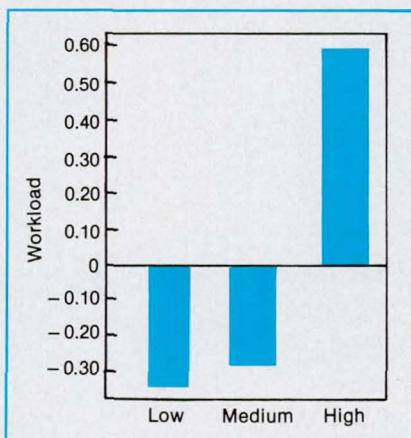

Figure 1. One Measure of Operator Workload is the mean normal operator "time stress" rating under low, medium, and high workload conditions.

Both methods are sensitive to the workload level and to individual subtasks in a continuing interactive computer task. They can pinpoint subtasks that press the operator and use up too much of the available time, perhaps leading to operator errors and even failure of the system.

The methods were tried in the NASA Deep Space Network, a computer system that acquires scientific, engineering, and tracking data from spacecraft. Nine experienced operators used the system under low, medium, and high workloads. They used standard equipment in a normal operating environment. A simulated task, composed of five subtasks and requiring a single operator, was designed for the study. It was typical of tracking-station tasks and involved initializing seven different computers so that they would be ready to track a designated spacecraft.

In the low-workload condition, the task was a simple setup with no complications; 12 minutes were allowed. In the medium-workload condition, the setup was extended and required an additional

pair of processors for another function; 20 minutes were allowed. In the high-workload condition, the extended task was used, and two computer failures were added. The allowed time remained at 20 minutes. In all three conditions, the allowed times were just enough to enable the completion of the tasks in the absence of malfunctions and errors.

The operators rated the subtasks according to two criteria: mental effort and pressure of time. They gave their ratings on a scale of 1 to 7 by pressing keys on their keyboards at the end of each subtask.

The operators' ratings were obtained directly from a computer printout. The time at which a rating was given was used to calculate the period of time the operator actually needed to do a subtask. This period was used to calculate the workload ratio from the standard allowable time established for the subtask. The pressure-of-time ratings correlated closely with the workload-ratio measurement (see figures).

The correlation indicates that they are measuring essentially the same thing, and one therefore can serve as a check on the other. However, they are not necessarily redundant in an uncontrolled situation in which one might be more readily usable. The pressure-of-time rating is especially easy to use and interpret. It is well-suited to on-the-spot diagnoses of operator problems. The workload ratio yields quantitative data on the time needed to perform subtasks and on the portion of task time spent on each subtask. It gives a clear indication when the operator approaches the allowed

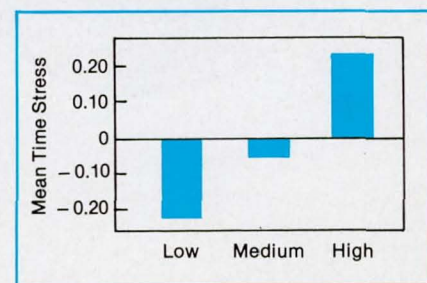

Figure 2. The Mean Normalized Workload ratio ($W = Tr/Ta$) under low, medium, and high workload correlates with the other measure of operator workload. (W = workload, Tr = time required by the operator to perform a specific subtask, and Ta = time allowed for that subtask.)

time and thus shows when the risk of trouble becomes high.

This work was done by Eric E. Hird

and Moira LeMay of Caltech for **NASA's Jet Propulsion Laboratory**. For further information, Circle 40 on the TSP Re-

quest Card.
NPO-16281

Books and Reports

These reports, studies, and handbooks are available from NASA as Technical Support Packages (TSP's) when a Request Card number is cited; otherwise they are available from the National Technical Information Service.

Updated Conceptual Cost Estimating

Kennedy Space Center cost data aid in efficient construction-cost management.

An 16-page report discusses the development and use of NASA TR-1508, the Kennedy Space Center Aerospace Construction Price Book (three volumes) for preparing conceptual, budget, funding, cost-estimating, and preliminary cost-engineering reports — an earlier version of the report is described in "Conceptual Cost Estimating" (KSC-11253), page 481, *NASA Tech Briefs*, Vol. 7, No. 4 (Summer 1983). The price book, containing over 480 pages of cost data, has been updated annually from 1974 through 1985 with actual bid prices and government estimates. It includes labor and material quantities and prices with contractor and subcontractor markups for buildings, facilities, and systems at the Kennedy Space Center. While the data pertain to aerospace facilities, the format and the cost-estimating techniques could guide the estimation of costs in other construction applications.

A conceptual cost estimate is used to assure cost control throughout a project. One of the best methods for making order-of-magnitude conceptual estimates is to find similar systems, buildings, or other elements of related design that have already been built and to adjust the costs of those elements for time, location, and current design requirements. With the aid of the unit bid prices thus derived, the conceptual budget estimates are more timely. This set of prices also serves as a rule of thumb and as cross-checking feedback for the evaluation of cost estimates of project details. The report shows an example using the KSC Cost In-

dex and Aerospace Price Book to make three different types of Conceptual Estimates for a \$10 million project.

This work was done by Joseph A. Brown of Kennedy Space Center. To obtain a copy of the report, "Conceptual Estimating of Shuttle Facilities Using Aerospace Construction Price Book," Circle 135 on the TSP Request Card. KSC-11344

Advanced Data Collection for Inventory Management

Bar-coding, radio-frequency, and voice-operated systems are selected.

A report discusses a study of the state-of-the-art in the automated collection of data for the management of large inventories. The study included a comprehensive search of the literature on data collection and inventory management, visits to existing automated inventory systems, and tours of selected supply and transportation facilities at the Kennedy Space Center. The information collected in these activities was analyzed in view of the needs of conceptual inventory-management systems for the Kennedy Space Center and for the manned space station and other future space projects.

Of the six technologies for automated data collection that were identified in the study, bar-coding, radio-frequency identification, and voice-operated systems were found to be viable considerations for the space station and Kennedy Space Center conceptual systems. Bar coding offers several advantages:

- It uses a computer-printable and computer-readable language.
- It is accurately and reliably readable.

- It is fast and easy to use.
- Equipment is readily available.
- The system is already in widespread use in the retail trades, and experience in the Department of Defense indicates that it saves money and improves the control and tracking of inventory.

A variety of radio-frequency identification systems are under development and in use, especially in the trucking and automobile-manufacturing industries. In such a system, a low-power transmitter/receiver irradiates a coded tag and reads the return signal, which is frequency modulated by the tag. There are both passive tags (which cannot be altered) and battery-powered active tags, which can be altered when irradiated with a signal containing a key code. An active tag can contain up to 8,000 bytes of information.

Voice systems (text-to-speech) would be used with bar coding or other systems to provide spoken guidance from a computer (test procedures, check lists, and the like) or audible alarms and warnings. Such systems are feasible because speech-synthesis techniques are relatively well developed. On the other hand, speech-recognition equipment has extremely limited capabilities. Consequently, a system for vocal data entry may not be available at a justifiable cost for several years.

The three technologies found unsuitable are optical character recognition, vision and image processing, and magnetic detection. Each was rejected for use in the conceptual systems because of the need for further adaptation to specific requirements, the need for further development, or limited utility.

This work was done by Gregory A. Opreško, Joel H. Leet, Daniel F. McGrath, and J. W. Eidson of Kennedy Space Center. To obtain a copy of the report, "Advanced Data Collection for Inventory Management," Circle 14 on the TSP Request Card. KSC-11349





Books and Reports

78 Increasing Maintainability of a Wastewater-Recovery Unit

Books and Reports

These reports, studies, and handbooks are available from NASA as Technical Support Packages (TSP's) when a Request Card number is cited; otherwise they are available from the National Technical Information Service.

Increasing Maintainability of a Wastewater-Recovery Unit

A modified system leaks less and is easier to disassemble for maintenance.

The redesign of a wastewater-recovery system that separates water from urine has improved operation and made the system easier to maintain. The details of the redesign, which chiefly affected the hollow-fiber-membrane evaporator, are described in a report.

Previously, the evaporator had to be removed as a unit and partly disassembled so that maintenance could be done on the 1,656 evaporator tubes grouped into 18 bundles. During 1,650 hours of operation, defects developed in the membrane bundle headers and in the steam-shell seals, forcing the shutdown of the system. The correction of the defects involved the disassembly of the evaporator — in a difficult, time-consuming procedure that often caused damage to parts and thereby necessitated further repair.

The major criteria for the redesign were the following:

- The new unit had to be completely interchangeable with the old unit;
- Leakage at the O-ring seals had to be reduced;
- The membrane-tube section had to be more maintainable; and
- While keeping the same membrane area, the number of tube-bundle headers had to be reduced to simplify assembly and maintenance while increasing reliability.

The most significant departure from the old arrangement was the reduction in the number of tube-bundle headers from 36 to 6. The length of each bundle was increased from 0.38 m to 2.29 m to provide adequate membrane area. The number of tube-to-header connections was reduced from 3,312 to 552, making it easier to remove them for maintenance. At the same time, reliability was in-

creased. The perforated metal retainers that prevented the tube-bundle headers from being forced through the header manifold were no longer needed; with their elimination, the header plug now forms a facial seal (in addition to the inherent radial seal) with the header manifold.

Among other changes, O-ring seals were made compressive between mating flange sections instead of radial between cylindrical sections. The compressive face-type seal is much less subject to leakage from expansion, contraction, and distortions in the mating surfaces.

Mating parts were fabricated from a single material, titanium, instead of polysulfone and titanium as before. The differing rates of thermal expansion and contraction between the two materials in the old unit had contributed to leakage around the radial seal.

This work was done by Gerard F. Dehner and Harlan F. Brose of United Technologies Corp. for Johnson Space Center. Further information may be found in NASA CR-171823 [N85-16468/NSP], "Addendum Development of a Preprototype TIMES Wastewater Recovery Subsystem."

Copies may be purchased [prepayment required] from the National Technical Information Service, Springfield, Virginia 22161, Telephone No. (703) 487-4650. Rush orders may be placed for an extra fee by calling (800) 336-4700. MSC-20984

NASA WANTS YOU

to tell your fellow citizens how you have applied NASA research in your products or processes.

For more information, call: **Linda Watts**
(301) 621-0241
NASA Spinoffs

A New Dimension in Portable, Digital Spectrum Analyzers!

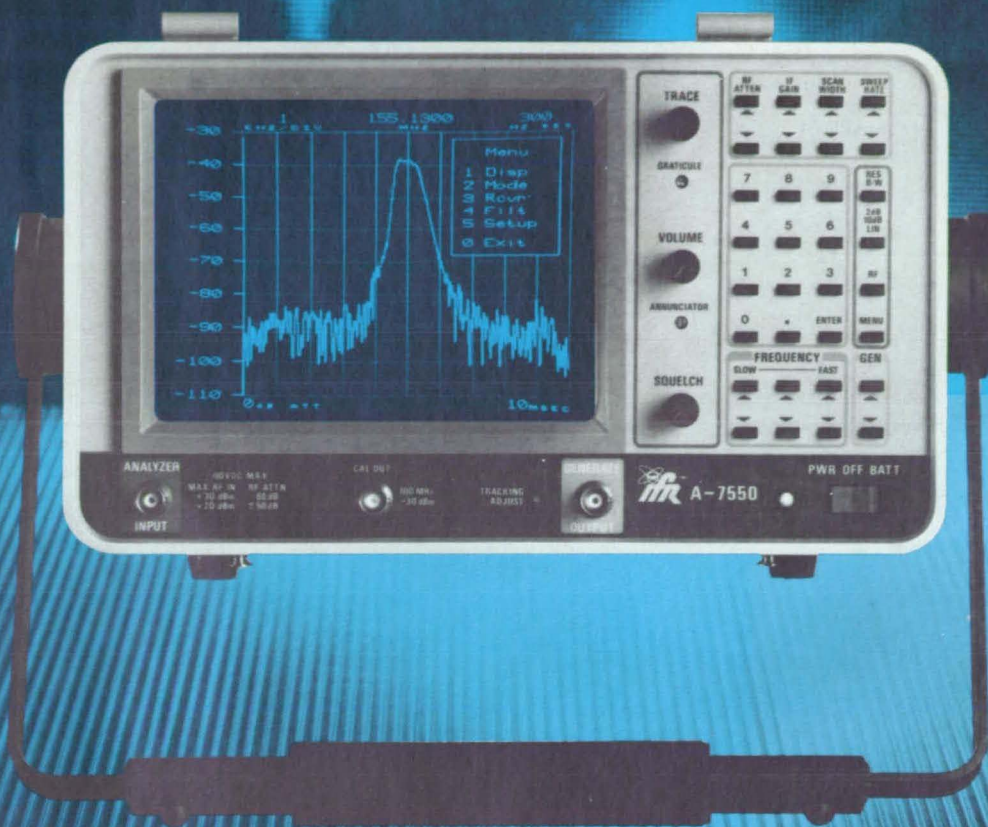

The A-7550 Spectrum Analyzer

The A-7550 Spectrum Analyzer by IFR is the most advanced, low cost, portable spectrum analyzer on the market today.

Two powerful microprocessors, menu driven display modes and single function keyboard entry aid the user in the operation of all analyzer functions.

To further enhance the operational simplicity of the A-7550, the microprocessor system automatically selects and optimizes the analyzers bandwidth, sweep rate, center frequency display resolution and the rate of the frequency slewing keys. An operator override is also provided when non-standard settings are required.

Features...Performance...Dependability...The A-7550 portable Spectrum Analyzer by IFR—innovative accomplishments in design.

Impressive Standard Features Include:

- 100 kHz to 1 GHz frequency coverage
- VRS™ (Vertical Raster Scan) CRT display
- Single function keyboard entry
- Menu driven display modes
- Automatic amplitude calibration
- Selectable linear/log display modes
- Digital storage of all displayed parameters
- 70 dB dynamic range
- 300 Hz resolution bandwidth
- 16 selectable scan widths
- Accurate center frequency readout
- Direct center frequency entry
- Automatically scaled electronic graticule
- Variable top scale reference (+30 to -95 in 1 dB steps)
- IF gain in 1 dB steps
- Line, bar, average and compare display modes
- 300 Hz and 30 kHz video filters

Optional Features Include:

- Internal rechargeable 5 APH battery for portable operation
- Tracking generator with 10 dB step attenuator
- Tracking generator with 1 dB step attenuator
- FMI/AM/SSB receiver
- IEEE-488 interface bus
- RS-232 interface bus
- 75Ω adaptor
- Quasi-peak detector



→ Contact your authorized IFR distributor for a demonstration.

IFR SYSTEMS, INC.
10200 West York Street / Wichita, Kansas 67215 U.S.A.
316 / 522-4981 / TWX 910-741-6952

Subject Index

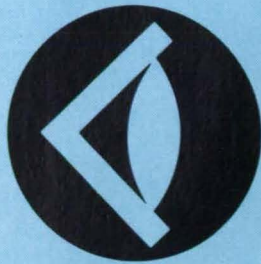

- A**
- ACOUSTIC LEVITATION**
Measuring shapes of acoustically levitated drops
page 32 NPO-16746
- AERODYNAMIC CONFIGURATIONS**
Design improvement for airplane-engine nacelles
page 59 ARC-11580
- AMORPHOUS SEMICONDUCTORS**
Amorphous-metal-film diffusion barriers
page 38 NPO-16637
- ARC LAMPS**
Vibration-resistant support for halide lamps
page 20 MSC-20523
- ATTITUDE CONTROL**
Three-axis attitude control with a single wheel
page 63 GSC-12970
- B**
- BALL BEARINGS**
Long-term tests of 38 ball-bearing greases
page 36 MFS-27089
- BARRIER LAYERS**
Amorphous-metal-film diffusion barriers
page 38 NPO-16637
- BEARINGS**
Magnetic bearing with radial and angular control
page 62 GSC-12957
- BOOMS (EQUIPMENT)**
Pultrusion fabrication of long boom models
page 70 LAR-13441
- BOUNDARY VALUE PROBLEMS**
Solving ordinary differential equations
page 42 NPO-16699
- BUBBLES**
Measuring shapes of acoustically levitated drops
page 32 NPO-16746
- BUCKLING**
Buckling analysis of rectangular plates with holes
page 42 LAR-13466
- C**
- CARBON FIBER REINFORCED PLASTICS**
Evaluation of fiber-reinforced composites
page 39 MFS-27149
- CENTRAL PROCESSING UNITS**
Design considerations for high-speed control systems
page 29 ARC-11670
- CERAMIC MATRIX COMPOSITES**
New polymeric precursors of silicon carbide
page 34 LEW-14272
- CERAMICS**
Making ceramic parts by laminating and sintering thin sheets
page 71 LEW-14361
- Measuring Poisson ratios at low temperatures
page 47 MFS-28107
- COATINGS**
Electrically conductive, heat-resistant paint
page 36 NPO-16325
- CODING**
Advanced data collection for inventory management
page 77 KSC-11349
- COMPUTER AIDED DESIGN**
Designing echelle spectrographs
page 40 GSC-13009
- COMPUTER SYSTEMS DESIGN**
Design considerations for high-speed control systems
page 29 ARC-11670
- CONNECTORS**
Quick-release panel fastener
page 44 MSC-20767
- CONSTANTAN**
Large wire strain gauges
page 58 MFS-28062
- CONSTRUCTION**
Updated conceptual cost estimating
page 77 KSC-11344
- CONTROL SYSTEMS DESIGN**
Design considerations for high-speed control systems
page 29 ARC-11670
- CONVERGENT-DIVERGENT NOZZLES**
Locating sonic lines in transonic nozzles
page 57 MFS-29163
- COST ESTIMATES**
Updated conceptual cost estimating
page 77 KSC-11344
- COUPLINGS**
Duplex wrench
page 46 MSC-20585
- CRACK PROPAGATION**
Specimen and holder for sliding-mode fatigue tests
page 55 LEW-14281
- CRACKS**
Side-looking viewer for crevices
page 46 MSC-20610
- CRYOGENICS**
MOSFET's for cryogenic amplifiers
page 25 MFS-27111
- D**
- DATA ACQUISITION**
Advanced data collection for inventory management
page 77 KSC-11349
- DIFFERENTIAL EQUATIONS**
Solving ordinary differential equations
page 42 NPO-16699
- DISSOCIATION**
In-vacuum dissociator for atomic-hydrogen masers
page 22 MFS-26007
- DROPS (LIQUIDS)**
Measuring shapes of acoustically levitated drops
page 32 NPO-16746
- E**
- ECHELETTE GRATINGS**
Designing echelle spectrographs
page 40 GSC-13009
- ELECTRIC BRIDGES**
Large wire strain gauges
page 58 MFS-28062
- ENCOUNTERS**
Predicting close satellite encounters
page 60 MSC-21102
- ENERGY TECHNOLOGY**
Residential photovoltaic/thermal energy system
page 66 NPO-15013
- ENVIRONMENTAL TESTS**
Long-term tests of 38 ball-bearing greases
page 36 MFS-27089
- ESCAPE SYSTEMS**
Service-life extension of explosive escape devices
page 48 LAR-13462
- ETCHING**
Deep, precise etching in semiconductors
page 72 NPO-16562
- EXHAUST NOZZLES**
Locating sonic lines in transonic nozzles
page 57 MFS-29163
- EXPLOSIVE DEVICES**
Service-life extension of explosive escape devices
page 48 LAR-13462
- EXTENSOMETERS**
Measuring Poisson ratios at low temperatures
page 47 MFS-28107
- F**
- FASTENERS**
Quick-release panel fastener
page 44 MSC-20767
- FATIGUE TESTS**
Specimen and holder for sliding-mode fatigue tests
page 55 LEW-14281
- FIBER OPTICS**
Optical welding torch
page 68 MFS-26034
- Water-cooled optical thermometer
page 30 NPO-16492
- FIELD EFFECT TRANSISTORS**
MOSFET's for cryogenic amplifiers
page 25 MFS-27111
- FIGURE OF MERIT**
High-temperature thermoelectric energy conversion
page 39 NPO-16548
- FILM THICKNESS**
Measuring thickness of wastewater films
page 23 MSC-20915
- FLOW DISTRIBUTION**
Analysis of scramjet inlets
page 42 LAR-13297
- FLUORESCENCE**
Containerless atomic-fluorescence property measurements
page 32 MFS-27070
- FLYWHEELS**
Three-axis attitude control with a single wheel
page 63 GSC-12970
- G**
- GALLIUM ARSENIDES**
Theoretical efficiencies of microwave diode triplers
page 24 NPO-16749
- GAS MASERS**
In-vacuum dissociator for atomic-hydrogen masers
page 22 MFS-26007
- GAS TUNGSTEN ARC WELDING**
Optical welding torch
page 68 MFS-26034
- GEOSYNCHRONOUS ORBITS**
Predicting close satellite encounters
page 60 MSC-21102
- Station-keeping maneuvers for geosynchronous spacecraft
page 60 NPO-16512
- GLOBAL POSITIONING SYSTEM**
VLBI system for satellite navigation
page 28 NPO-16319
- GRAPHITE-EPOXY COMPOSITES**
Evaluation of fiber-reinforced composites
page 39 MFS-27149
- GREASES**
Long-term tests of 38 ball-bearing greases
page 36 MFS-27089
- GUARDS (SHIELDS)**
High-pressure transducer package
page 56 MFS-28054
- GYROSCOPES**
Three-axis attitude control with a single wheel
page 63 GSC-12970
- H**
- HALOGENS**
Field-reversal source for negative halogen ions
page 31 NPO-16247
- HEAT PUMPS**
Characteristics and applications of metal hydrides
page 65 MFS-26028
- HEAT TRANSMISSION**
Thermal-analysis program
page 42 MSC-21140
- HINGES**
Elastic hinge for solar-cell array
page 69 MFS-28133
- HOUSINGS**
High-pressure transducer package
page 56 MFS-28054
- HUMAN PERFORMANCE**
Measuring computer-operator workload
page 76 NPO-16281
- HYDROGEN**
Characteristics and applications of metal hydrides
page 65 MFS-26028
- HYDROGEN MASERS**
In-vacuum dissociator for atomic-hydrogen masers
page 22 MFS-26007
- HYDROGEN PRODUCTION**
Producing hydrogen with sunlight
page 33 NPO-16728
- I**
- INFRARED ASTRONOMY**
MOSFET's for cryogenic amplifiers
page 25 MFS-27111
- INLET FLOW**
Analysis of scramjet inlets
page 42 LAR-13297
- INVENTORY MANAGEMENT**
Advanced data collection for inventory management
page 77 KSC-11349
- ION BEAMS**
Field-reversal source for negative halogen ions
page 31 NPO-16247
- L**
- LAMINATES**
Making ceramic parts by laminating and sintering thin sheets
page 71 LEW-14361
- LASER SPECTROSCOPY**
Containerless atomic-fluorescence property measurements
page 32 MFS-27070
- LIQUID WASTES**
Increasing maintainability of a wastewater-recovery unit
page 78 MSC-20984
- Measuring thickness of wastewater films
page 23 MSC-20915
- M**
- MACHINE TOOLS**
Switching circuit for shop vacuum system
page 64 MFS-29153
- MAGNETIC BEARINGS**
Magnetic bearing with radial and angular control
page 62 GSC-12957
- MANAGEMENT**
Updated conceptual cost estimating
page 77 KSC-11344
- MANIPULATORS**
Position control for nonlinear, multiple-link robots
page 66 NPO-16806
- MECHANICAL PROPERTIES**
Evaluation of fiber-reinforced composites
page 39 MFS-27149
- METAL HYDRIDES**
Characteristics and applications of metal hydrides
page 65 MFS-26028
- METAL PLATES**
Buckling analysis of rectangular plates with holes
page 42 LAR-13466
- MINES (EXCAVATIONS)**
Molded concrete center mine wall
page 70 NPO-16195
- N**
- NACELLES**
Design improvement for airplane-engine nacelles
page 59 ARC-11580
- NEGATIVE IONS**
Field-reversal source for negative halogen ions
page 31 NPO-16247
- NOISE GENERATORS**
Radar time-base and pseudonoise generator
page 26 NPO-16361
- NUTS (FASTENERS)**
Duplex wrench
page 46 MSC-20585
- O**
- OPERATORS (PERSONNEL)**
Measuring computer-operator workload
page 76 NPO-16281
- OPTICAL EQUIPMENT**
Side-looking viewer for crevices
page 46 MSC-20610
- OPTICAL PYROMETERS**
Water-cooled optical thermometer
page 30 NPO-16492
- ORBITAL MECHANICS**
Station-keeping maneuvers for geosynchronous spacecraft
page 60 NPO-16512
- ORTHOTROPIC PLATES**
Buckling analysis of rectangular plates with holes
page 42 LAR-13466
- P**
- PACKAGES**
High-pressure transducer package
page 56 MFS-28054
- PAINTS**
Electrically conductive, heat-resistant paint
page 36 NPO-16325
- PANELS**
Quick-release panel fastener
page 44 MSC-20767
- PHOTODECOMPOSITION**
Producing hydrogen with sunlight
page 33 NPO-16728
- PIVOTS**
Elastic hinge for solar-cell array
page 69 MFS-28133
- POISSON RATIO**
Measuring Poisson ratios at low temperatures
page 47 MFS-28107

POLYMER MATRIX COMPOSITES
Pultrusion fabrication of long boom models
page 70 LAR-13441

PREAMPLIFIERS
MOSFET's for cryogenic amplifiers
page 25 MFS-27111

PRESSURE SENSORS
High-pressure transducer package
page 56 MFS-28054

PSEUDONOISE
Radar time-base and pseudonoise generator
page 26 NPO-16361

PULTRUSION
Pultrusion fabrication of long boom models
page 70 LAR-13441

Q

QUARTZ LAMPS
Vibration-resistant support for halide lamps
page 20 MSC-20523

R

RADAR RESOLUTION
Radar time-base and pseudonoise generator
page 26 NPO-16361

RADIOACTIVE WASTES
Concept for underground disposal of nuclear waste
page 34 NPO-16042

REMOTE MANIPULATOR SYSTEM
Position control for nonlinear, multiple-link robots
page 66 NPO-16806

RESIDENTIAL ENERGY
Residential photovoltaic/thermal energy system
page 66 NPO-15013

RESISTANCE THERMOMETERS
Two-range electrical thermometer
page 24 MFS-28145

ROTORS
Magnetic bearing with radial and angular control
page 62 GSC-12957
Position control for nonlinear, multiple-link robots
page 66 NPO-16806

S

SATELLITE NAVIGATION SYSTEMS
VLBI system for satellite navigation
page 28 NPO-16319

SATELLITE ORBITS
Predicting close satellite encounters
page 60 MSC-21102

SCHOTTKY DIODES
Theoretical efficiencies of microwave diode triplers
page 24 NPO-16749

SEMICONDUCTOR DEVICES
Amorphous-metal-film diffusion barriers
page 38 NPO-16637
Deep, precise etching in semiconductors
page 72 NPO-16562

SEMICONDUCTORS (MATERIALS)
High-temperature thermoelectric energy conversion
page 39 NPO-16548

SERVICE LIFE
Service-life extension of explosive escape devices
page 48 LAR-13462

SHADOWS
Measuring shapes of acoustically levitated drops
page 32 NPO-16746

SILANES
New polymeric precursors of silicon carbide
page 34 LEW-14272

SILICON CARBIDES
New polymeric precursors of silicon carbide
page 34 LEW-14272

SINTERING
Making ceramic parts by laminating and sintering thin sheets
page 71 LEW-14361

SOLAR ARRAYS
Elastic hinge for solar-cell array
page 69 MFS-28133

SOLAR ENERGY CONVERSION
Producing hydrogen with sunlight
page 33 NPO-16728

Residential photovoltaic/thermal energy system
page 66 NPO-15013

SOLID STATE DEVICES
Deep, precise etching in semiconductors
page 72 NPO-16562

SPECIMEN GEOMETRY
Specimen and holder for sliding-mode fatigue tests
page 55 LEW-14281

SPECTROGRAPHS
Designing echelle spectrographs
page 40 GSC-13009

STATIONKEEPING
Station-keeping maneuvers for geosynchronous spacecraft
page 60 NPO-16512

STRAIN GAGES
Large wire strain gauges
page 58 MFS-28062

SUPERSONIC COMBUSTION RAMJET ENGINES
Analysis of scramjet inlets
page 42 LAR-13297

SWITCHING CIRCUITS
Switching circuit for shop vacuum system
page 64 MFS-29153

T

TEMPERATURE MEASURING INSTRUMENTS
Two-range electrical thermometer
page 24 MFS-28145
Water-cooled optical thermometer
page 30 NPO-16492

TEMPERATURE PROFILES
Thermal-analysis program
page 42 MSC-21140

THERMAL ANALYSIS
Thermal-analysis program
page 42 MSC-21140

THERMAL CONTROL COATINGS
Electrically conductive, heat-resistant paint
page 36 NPO-16325

THERMOCHEMISTRY
Containerless atomic-fluorescence property measurements
page 32 MFS-27070

THERMOELECTRIC POWER GENERATION
High-temperature thermoelectric energy conversion
page 39 NPO-16548

THERMOMETERS
Two-range electrical thermometer
page 24 MFS-28145

TITANIUM
Electrically conductive, heat-resistant paint
page 36 NPO-16325

TRAJECTORY ANALYSIS
Solving ordinary differential equations
page 42 NPO-16699

TRANSONIC NOZZLES
Locating sonic lines in transonic nozzles
page 57 MFS-29163

U

UNDERGROUND STORAGE
Concept for underground disposal of nuclear waste
page 34 NPO-16042

Two-range electrical thermometer
page 24 NPO-16042

UNDERGROUND STRUCTURES
Molded concrete center mine wall
page 70 NPO-16195

URINE
Increasing maintainability of a wastewater-recovery unit
page 78 MSC-20984

V

VACUUM SYSTEMS
Switching circuit for shop vacuum system
page 64 MFS-29153

VARIATORS
Theoretical efficiencies of microwave diode triplers
page 24 NPO-16749

VENTILATION
Molded concrete center mine wall
page 70 NPO-16195

VERY LONG BASE INTERFEROMETRY
VLBI system for satellite navigation
page 28 NPO-16319

VIBRATION ISOLATORS
Vibration-resistant support for halide lamps
page 20 MSC-20523

VIEWING
Side-looking viewer for crevices
page 46 MSC-20610

W

WASTE DISPOSAL
Concept for underground disposal of nuclear waste
page 34 NPO-16042

WASTE UTILIZATION
Increasing maintainability of a wastewater-recovery unit
page 78 MSC-20984

WATER RECLAMATION
Measuring thickness of wastewater films
page 23 MSC-20915

WELDING
Optical welding torch
page 68 MFS-26034

WING NACELLE CONFIGURATIONS
Design improvement for airplane-engine nacelles
page 59 ARC-11580

WORKLOADS (PSYCHOPHYSIOLOGY)
Measuring computer-operator workload
page 76 NPO-16281

WRENCHES
Duplex wrench
page 46 MSC-20585

ERIM REPORT #6a

3D Sensor Developments

Three-dimensional (3D) sensor technology first demonstrated at ERIM in 1976 is providing exciting new capabilities in a variety of applications.

The 3D Sensor

The 3D sensor technology being developed at ERIM is based on the principles of optical radar. A modulated laser beam is rapidly scanned over the scene and the reflected energy is processed to extract phase information and provide a signal proportional to range. Thus, directed measurements of a scene's geometrical characteristics are obtained.

Mobility and Navigation

ERIM's 3D sensor technology is providing an excellent alternative to human stereo vision in control systems for future autonomous land vehicles (ALV) that will operate in environments too hostile for man. ERIM 3D sensing units are also being used in the Ohio State University Adaptive Suspension Vehicle (ASV) to provide automatic "subconscious" functions of attitude control and detailed foot placement for both forward and turning movements.

Future Robots

Future robots for factory automation will be part of a larger system that includes 3D vision to obtain information about the robot's surroundings. The 3D vision sensor will enable the robot to automatically account for such things as obstacles and misoriented parts and to perform parts inspection by accurate shape measurements.

Career Opportunities

ERIM has research and management positions available in Ann Arbor, MI, Washington DC, Dayton, OH and Ft. Walton Beach, FL. Positions are available at several levels in the following areas:

- Radar System Design
- E-O/IR System Design and Analysis
- Computer Vision
- Optical Computer System
- Phase Retrieval/Signal Reconstruction
- Radar System Engineering and Analysis
- Signal and Image Processing
- Microwave Scattering and Measurement Engineering
- Diffractive Optics

All positions require a BS, MS, or PhD in engineering, physics, mathematics, or statistics, along with appropriate work experience. Salary and benefits are highly competitive.

For details, telephone (313) 994-1200, ext. 3260. Or send your resume to Personnel Administrator, Dept. NT, ERIM, P.O. Box 8618, Ann Arbor, MI 48107-8618.



U.S. Citizenship required/Equal opportunity employer

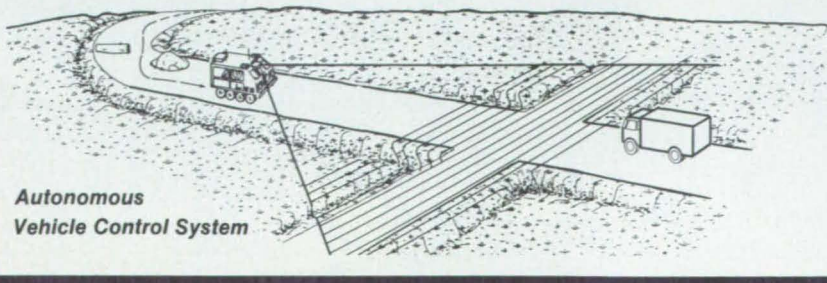

Autonomous Vehicle Control System

Mission **A**ccomplished

Through the technology transfer process, many of the systems, methods and products pioneered by NASA are reapplied in the private sector, obviating duplicate research and making a broad range of new products and services available to the public.

It was a "g'day" indeed for American technology when Stars & Stripes recaptured sailing's most coveted prize, the America's Cup.

The victorious U.S. yacht in the 12-meter race at Fremantle, Australia, held a hidden edge over the competition: its hull was laminated with a grooved plastic skin designed to make the craft slide through the sea more smoothly. This innovation originated at NASA's Langley Research Center. Ironically, so did the technology that caused the U.S. to lose the Cup in the first place.

When Langley's Dr. Richard Whitcomb developed the vertical, wing-like configurations called "winglets," he didn't know the Australians would use his invention to snatch away a trophy the U.S. had kept for more than a century.

Above: Michael J. Walsh, riblet inventor. Below right: Riblet shapes as they appeared in the Summer, 1980 edition of NASA Tech Briefs.



"I started winglet research in 1974 to reduce the drag of wings, not sailboats," said Dr. Whitcomb. The winglets decreased drag by weakening the vortices forming behind an airplane's wing tips. Dr. Joop Sloof, a Dutch aerodynamicist, later applied this technology to racing boats.

"We considered winglets in 1983," said Johan Valentijn, designer of the Eagle, another U.S. challenger yacht. "Our judgement was they'd disqualify us from the competition if we used them." But Australia II did utilize the design on its "winged keel," and scored an upset victory.

NASA taketh away and NASA giveth back. Three years later, "riblets," another product of Langley aerodynamic research during the 1970's, went down under to rescue the Cup.

"In the mid-70's, right after the oil embargo, everybody was thinking of ways to save fuel," recalled Michael J. Walsh, a scientist in Langley's High-Speed Aerodynamics Division. "We were working on ways to reduce airplane fuel consumption. I think the airlines were then spending \$12-15 billion a year on fuel. If we could make the planes go faster, those costs would go way down."

Walsh sought to decrease the intensity of the violent "bursts" responsible for most skin friction drag on an aircraft. Experiments showed that minute grooves etched onto a plane's fuselage could reduce skin friction by approximately ten percent, with associated fuel savings of \$200-300 million per year.

Aligned in the direction of airflow, the v-shaped micro-grooves, named riblets, would act as tiny fences, favor-

ably altering turbulent winds. The first riblets, machined on flat aluminum surfaces and tested in Langley wind tunnels, reduced friction drag eight percent over ungrooved surfaces.

These test results were published in the Summer, 1980 issue of *NASA Tech Briefs*, in a brief entitled "Grooves Reduce Aircraft Drag." "It was through the tech brief that the 3M Company first applied our riblet research," said Walsh. "Frank Marantec called me after he read the brief."

Mr. Marantec, a 3M engineer, offered an idea: it would be easier to mold grooves into a lightweight plastic film with an adhesive backing and press it into place on an airplane. If the film surface became damaged, the worn section could be replaced. In addition, the adhesive film could be economically applied to existing aircraft. No welding was necessary.

3M's Decorative Products Division developed adhesive-coated films with precisely machined riblet surfaces that, in Langley wind tunnel tests, reduced turbulent drag as effectively or better than the earlier aluminum version. 3M reported these findings to the Boeing Company, the world's largest producer of commercial aircraft, where the idea of applying the film to boats first came about.

"Bob Ernst, the coach from the University of Washington, approached me about the Olympic crew races," explained Arvel Gentry, manager of CAD Utility Applications at Boeing. "He asked if there was anything to make a faster crew shell. One possibility I offered was using riblet film on the shell. I didn't have time to look into the request, but I gave him Doug McLean's name."

McLean, a Boeing engineer familiar with the riblet film through an experiment applying the technology to Boeing 747s, began testing one-man rowing shells at Seattle's Puget Sound. When laminated with 3M film, the racing shells registered a six percent total drag reduction.

Bolstered by these results, McLean journeyed to Los Angeles, site of the 1984 Summer Olympics. According to Arvel Gentry, "McLean and his group stood with their shells outside the areas where the Olympic teams hang around, trying to get one of the teams, any of the teams, to try the film."

McLean finally persuaded Dietrich Rose, Olympic rowing coach, to use the 3M tape on a four-oar-with-coxswain shell. As competition was already under way, there was no time to test the shell in the water before the race. Engineers working against the clock applied film to the shell in a single afternoon. The result? A silver medal in an event the U.S. had been shut out of for many years.

Meanwhile, Britton Chance, the ma-

rine architect who designed Stars & Stripes, was exploring the possibilities of speeding up sailboats. Chance met William Friedlander, a 3M scientist, during a party at Minnesota's St. Croix River Sailing Club. Friedlander invited Dr. Chance to present a seminar on yacht design at 3M, during which Chance learned of the riblet technology. Enticed, he commissioned use of computer modelling by the Massachusetts Institute of Technology. The computer models displayed a major reduction of skin drag when comparing a sailing model with the film applied versus an identical model without the film.

The first true test came at Fremantle in December, 1986. Dennis Conner, captain of Stars & Stripes, had brought two yachts to Australia: his competition boat and a 1985 model serving as a benchmark. As an experiment, the 1985 yacht, 25% laminated with riblet film, was pitted against the uncovered Stars & Stripes. When the older boat consistently outdistanced Stars & Stripes, Conner was convinced.

"Conner completely lost his benchmark," explained Clem Nelson, vice-president of 3M's Decorative Products Division. "He immediately summoned Frank Marantec to Australia and had him cover the Stars & Stripes hull with 3M film."

Approximately 30 panels of adhesive tape, each three square feet, were applied to the racing yacht.

On February 5, 1987, Stars & Stripes recorded a one minute, 59 second win over Australia's Kookaburra III to complete a 4-0 sweep in the America's Cup finals.

"Everybody believed the riblets made the difference," commented Tom Wilson, a San Diego Yacht Club spokesman. "Putting riblets on the hull gave a real psychological boost to the crew."

"There's no doubt the riblet film provided a significant reduction in friction drag and that obviously translated into a higher boat speed," added John Marshall, coordinator of the Stars & Stripes design team.

As for the future, potential riblet applications include fluid transmissions (oil, gas, or water pipeline), Navy Submarines, and turbine blades for jet engines.

Though 3M isn't making specific projections on the commercialization of riblets, the company has high expectations. "We're marketing the film in March, which is much earlier than we expected," Clem Nelson revealed. "I can see it becoming a business unit of its own by 1988."

According to Nelson, 3M is "actively persuading working with Boeing for development of the riblet technology in commercial aviation."

But for now, the technology is best known as a hull of an idea that brought a 136-year-old trophy back home. □

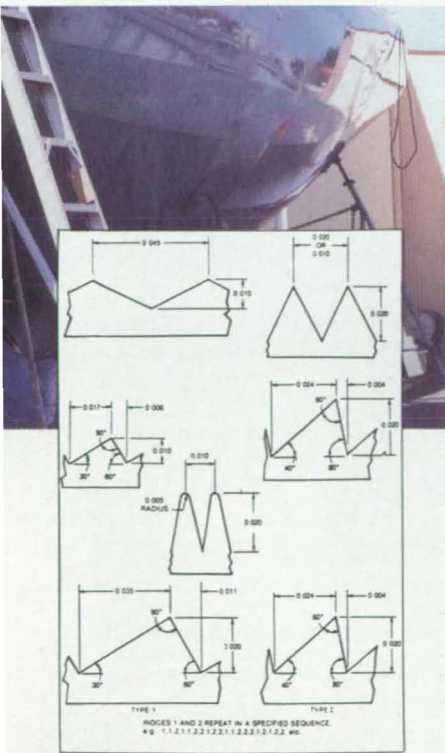

CAMAC

(IEEE-583)

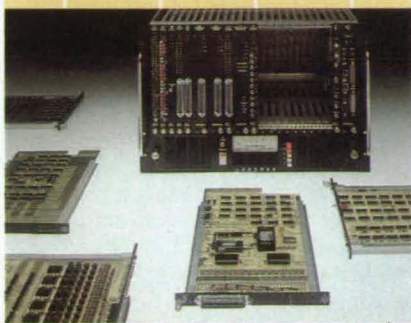

Your Standard Tools for Data Acquisition and Control

For 15 years, KSC has been supplying users in laboratories, plants, and R & D facilities with practical CAMAC (IEEE-583) hardware and software tools for automation. The reason is simple. CAMAC, the international standard for Computer Automated Measurement And Control, provides modular real-time data acquisition and control solutions that can be implemented a step at a time.

CAMAC features . . .

Full Standardization. Specified by the IEEE, ANSI, and IEC.

Open-end Architecture. Start as small as you like and expand when and how you want.

Multicomputer Support. Interfaces for a wide range of computers, such as DEC, CDC, MODCOMP, Gould/SYSTEMS, and Hewlett-Packard.

High Data Rates. Data transfer rates to 348,000 bytes per second with DMA interfaces.

Unsurpassed Selection of Process I/O Modules. From A/D and D/A converters and signal multiplexers to event counters and transient recorders.

Powerful Distributed Systems. Peak block rates up to three million data bytes per second over a fiber optic serial highway to as many as 62 remote stations.

Supporting Software. Easy to use CAMAC handlers, software drivers, and Process Control/Data Base System software packages.

Field-proven System Design. Used in such facilities as Boeing, Nalco Chemical, Kimberley-Clark, Digital, NASA, Bell Labs, Martin Marietta, DuPont, and General Electric.

Join the growing list of users who are specifying our CAMAC tools for their system development. Call us today.

Kinetic Systems Corporation

11 Maryknoll Dr., Lockport, IL 60441
(815) 838-0005
TWX: 910 635 2831

Feedback

VOTE OF CONFIDENCE

I vote "Digital Fly-By-Wire" best computer article for non-computer people.

Alan Richer
Senior Structural Design Engineer
Grumman Corporation
Bethpage, NY

LET YOUR FINGERS . . .

It would be helpful to publish phone numbers of various technical personnel or even a base information phone number (telephone operators are not helpful).

J.R. Dowell
Materials Engineer
L-T-V Missiles
Dallas, TX

Please try the Industrial Application Centers first, or the Technology Utilization Officers. They're your best contacts, and know how to get to the right people.—Editor

RETURN TO SENDER

I used several articles and Technical

Support Packages (TSPs) on Power Factor Controllers and have closely followed track/train dynamics. I used to get *Tech Briefs* as recently as six months ago, but everything mysteriously stopped without warning.

Karl F. Strauss
Senior Engineer
Jet Propulsion Laboratory
Pasadena, CA,

That's what happens if you don't tell us when you move. Nota bene to any other reader who is moving—let us know early so your subscription won't stop without warning.

—Editor

IN BRIEF

Better format for ideas is needed. It takes too long to browse through your present layout. I would suggest three levels of presentation: 1) title only, 2) one or three sentences maximum, and 3) the detailed writeups you presently have.

Vernon A. Anderson
Program Director
Department of the Navy, Naval Weapons Center
China Lake, CA

Advertiser's Index

APS Materials, Inc.	(RAC* 489)	37
Aptec Computer Systems	(RAC 314)	6-7
Astro Met Associates Inc.	(RAC 484)	39
BEI Motion Systems Co.	(RAC 337)	COV III
Boeing Technology Services	(RAC 367)	COV II
Brush Wellman Inc.	(RAC 490)	14
Corning Glass Works	(RAC 454)	75
Data-Control Systems	(RAC 371)	27
Digilab, Division of Bio Rad.	(RAC 485)	13
Dresser Instrument Division/Heise	(RAC 470)	74
ERIM	(RAC 475)	81
Fisher Pen Company	(RAC 451)	59
Fluoramics Inc.	(RAC 455)	17
GAF Corporation	(RAC 404)	12
Gould Inc., Recording Systems Division	(RAC 486)	15
Greene, Tweed & Co.	(RAC 328)	60
Heath Tecna Aerospace Co.	(RAC 487)	45
Honeywell Test Instruments Division	(RAC 364)	28-29
Howmet Turbine Components Corp.	(RAC 335)	35
IFR Systems, Inc.	(RAC 317)	79
Kinetic Systems Corp.	(RAC 316)	84
Klinger Scientific Corp.	(RAC 368)	9
Logica	(RAC 491)	8
Martin Marietta/recruitment	(RAC 440)	85
McDonnell Douglas Corp.	(RAC 372,374)	73, COV IV
NEC America, Inc.	(RAC 369)	1
Nicolet Test Instruments Div.	(RAC 350)	21
NTS Testing	(RAC 358)	25
Oriel Corporation	(RAC 488)	4
Pennwalt Corporation	(RAC 425)	41
Pressure Systems Inc.	(RAC 378)	2
RR Software Inc.	(RAC 467)	43
Scanivalve Corporation	(RAC 381)	61
Tektronix Inc., AI Marketing	(RAC 462)	5
Teledyne Taber	(RAC 479)	38
Valcor Engineering Corp.	(RAC 326)	65
Velmex, Inc.	(RAC 447)	39
Vitro Corporation	(RAC 394)	67

*RAC stands for Reader Action Card. For further information on these advertisers, please circle the RAC number on the Reader Action Card elsewhere in this issue. This index has been compiled as a service to our readers and advertisers. Every precaution is taken to ensure its accuracy, but the publisher assumes no liability for errors or omissions.

GIVING ROBOTICS SOME SERIOUS THOUGHT

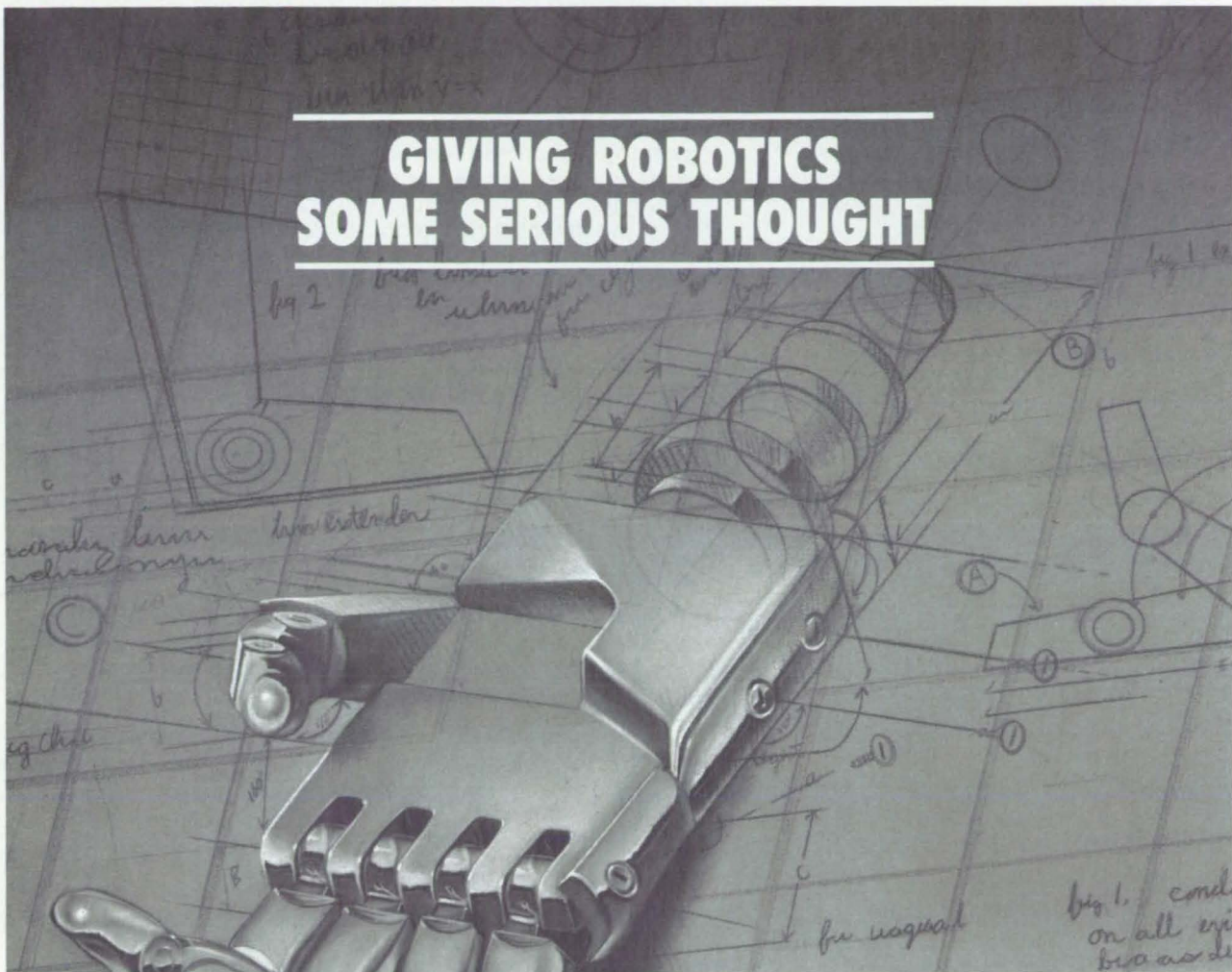

and real-time displays for command and control systems.

At Baltimore Aerospace, we're giving robotics some serious thought. In fact, we're investing millions for research, equipment and facilities to further advance these technologies.

We invite you to be a part of this effort. If you have experience in robotics or artificial intelligence, give some serious thought to a career at Baltimore Aerospace. We have opportunities available in the following areas:

- **Servo Control Analysis & Simulation**
- **Sensor System Design & Applications**
- **Autonomous Underwater Vehicles**

Imagine a robotic device that will allow the operator to see and feel what the robot is seeing and feeling. A device controlled easily and reliably, in much the same way as a human hand. This is "telepresence." And it's a technology being advanced at Martin Marietta Baltimore Aerospace.

Telepresence is just part of the work being performed in military automation and robotics at Baltimore Aerospace. There's also on-going research in autonomous underwater vehicle systems, supervised control of remote vehicles, military robotics, expert systems for battle management and C³I systems,

- **System Design Requirements: Mechanical/Electrical**
- **Man-Machine Interface/ Human Factors**
- **Mechanism Design & Analysis**
- **Real-Time Hierarchical Control Systems**
- **Real-Time Computer Graphics for Animation**
- **AI Programming**
- **Operation Analysis**
- **C³I**
- **Biomedical Engineering**
- **Unmanned Vehicle Systems**

If interested please send your resume to: Martin Marietta Baltimore Aerospace, Employment Dept. NTB387, 103 Chesapeake Park Plaza, Baltimore, Maryland 21220. U.S. Citizenship Required. An Equal Opportunity Employer m/f/h/v.

MARTIN MARIETTA

ABOUT THE NASA TECHNOLOGY UTILIZATION PROGRAM

Thumb Index



NASA TU Services



New Product Ideas



Electronic Components and Circuits



Electronic Systems



Physical Sciences



Materials



Computer Programs



Mechanics



Machinery



Fabrication Technology



Mathematics and Information Sciences



Life Sciences



Subject Index

This document was prepared under the sponsorship of the National Aeronautics and Space Administration. NASA Tech Briefs is published ten times a year and is free to engineers in U.S. industry and to other domestic technology transfer agents. It is both a current-awareness medium and a problem-solving tool. Potential products... industrial processes... basic and applied research... shop and lab techniques... computer software... new sources of technical data... concepts... can be found here. The short section on New Product Ideas highlights a few of the potential new products contained in this issue. The remainder of the volume is organized by technical category to help you quickly review new developments in your areas of interest. Finally, a subject index makes each issue a convenient reference file.

Further information on innovations—Although some new technology announcements are complete in themselves, most are backed up by Technical Support Packages (TSP's). TSP's are available without charge and may be ordered by simply completing a TSP Request Card, found at the back of this volume. Further information on some innovations is available for a nominal fee from other sources, as indicated. In addition, Technology Utilization Officers at NASA Field Centers will often be able to lend necessary guidance and assistance.

Patent Licenses—Patents have been issued to NASA on some of the inventions described, and patent applications have been submitted on others. Each announcement indicates patent status and availability of patent licenses if applicable.

Other Technology Utilization Services—To assist engineers, industrial researchers, business executives, Government officials, and other potential users in applying space technology to their problems, NASA sponsors Industrial Applications Centers. Their services are described on pages 14-15. In addition, an extensive library of computer programs is available through COSMIC, the Technology Utilization Program's outlet for NASA-developed software. See special section on computer programs on page 56.

Applications Program—NASA conducts applications engineering projects to help solve public-sector problems in such areas as safety, health, transportation, and environmental protection. Two applications teams, staffed by professionals from a variety of disciplines, assist in this effort by working with Federal agencies and health organizations to identify critical problems amenable to solution by the application of existing NASA technology.

Reader Feedback—We hope you find the information in *NASA Tech Briefs* useful. A reader-feedback card has been included because we want your comments and suggestions on how we can further help you apply NASA innovations and technology to your needs. Please use it; or if you need more space, write to the Manager, Technology Transfer Division, P.O. Box 8757, Baltimore/Washington International Airport, Maryland 21240.

Advertising Reader Service—Reader Action Card (RAC): For further information on the advertisers, please circle the RAC number on the separate Reader Action Card in this issue.

Change of Address—If you wish to have *NASA Tech Briefs* forwarded to your new address, use the Subscription Card enclosed at the back of this volume of *NASA Tech Briefs*. Be sure to check the appropriate box indicating change of address, and also fill in your identification number (T number) in the space indicated.

This document was prepared under the sponsorship of the National Aeronautics and Space Administration. Neither Associated Business Publications Co., nor anyone acting on behalf of Associated Business Publications Co., nor the United States Government nor any person acting on behalf of the United States Government assumes any liability resulting from the use of the information contained in this document, or warrants that such use will be free from privately owned rights. The U.S. Government does not endorse any commercial product, process, or activity identified in this publication.

MICRORADIAN POINTING AND PRECISE TRACKING FROM BEI'S ULTRA-LOC® CONTROL SYSTEMS

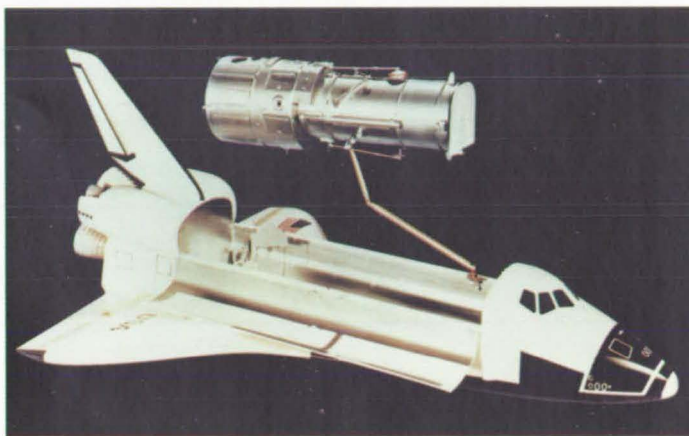

BEI's LED-equipped optical encoders help position the space shuttle arm and provide guide star position data on NASA's Hubble Space Telescope.



This totally integrated motor-encoder system for the Hubble Space Telescope provides resolution and accuracy to 21 bits.



The space shuttle's remote manipulator arm uses high-reliability BEI encoders.



BEI's two-axis pedestal with integral motor-encoders.



Our remarkable code disk, unequalled for accuracy in the world ... and beyond.

Our experience in providing high resolution and high accuracy space hardware is second to none.

BEI's two axis pedestal with integral motor-encoders eliminates coupling error and provides repeatable pointing to better than one microradian.

The direct drive capability of our Ultra-Loc® systems has a high

servo band width (typically >50 HZ) for standard models with torque to 30 lb.-ft. Small angle settling time is less than 100 milliseconds for 21-bit resolution.

In 1979, BEI's Ultra-Loc® precision drive with LED-equipped motor-encoders were selected for the space telescope's fine guidance system. This lightweight

beryllium motor-encoder is totally integrated including motor commutation. It provides resolution and accuracy to 21-bits.

Our long established systems and procedures are in compliance with quality criteria NHB-5300.4(1B) and MIL-Q-9858A, and high reliability criterion MIL-STD-785. Contact BEI for more details.



BEI MOTION SYSTEMS COMPANY

Digital Products Division

P.O. Box 3838 ■ Little Rock, AR 72203 ■ (501) 851-4000

Circle Reader Action No. 337

AN OBSERVATION POST LIKE NO PLACE ON EARTH.

The better we can monitor our planet, the better we can manage our resources, aid our population, and anticipate geophysical crises.

NASA's space station will allow us for the first time to understand how the Earth works as a system—how the air, oceans and land masses interact.

Using Earth viewing sensors on both a manned base and on unmanned platforms, the station will give us a new

perspective on our planet for weather forecasting, oil and mineral exploration, crop and water management, natural disaster monitoring, pollution control, and even rescue operations.

That's one reason why McDonnell Douglas and team members Honeywell, IBM, Lockheed and RCA are working with NASA to put a manned space station in orbit in the 1990s.

For three decades, we've worked toward making a

manned space station operational. We've built space laboratories, flown space factories, and tested space station frameworks.

An Earth observation system on the space station will help us use our planet's resources more wisely and efficiently. And we think that's a very good reason to build an observation post like no place on Earth.

*For more information, write:
McDonnell Douglas, Space Station,
P.O. Box 14526, St. Louis, MO 63178.*

Circle Reader Action No. 372



MCDONNELL DOUGLAS

© 1987 McDonnell Douglas Corporation