

NASA Tech Briefs

National
Aeronautics and
Space
Administration

January/February 1986
Volume 10 Number 1

**Johnson Space Center:
Beyond Mission Control**

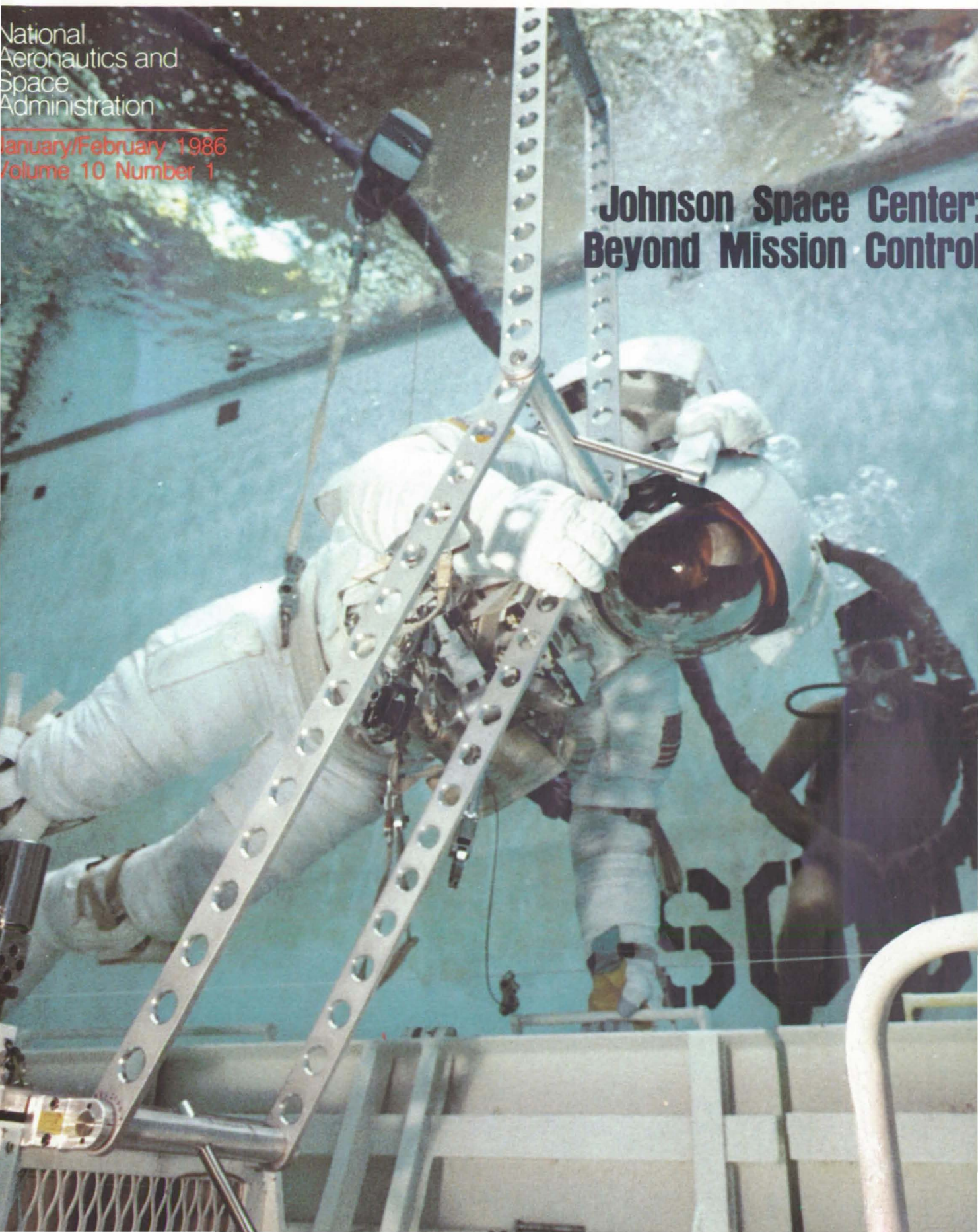

The next step: a space station that means business.

NASA has targeted the 1990s for deployment of a permanently manned space station. Martin Marietta is aiming to help NASA meet its date with advanced development of systems and spacecraft. As the permanently manned space station becomes a reality, it will open a new era of opportunity for government, science and private enterprise.

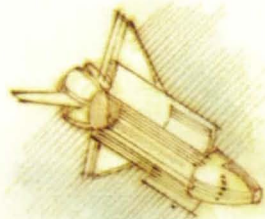

Attitude control system

Solar array

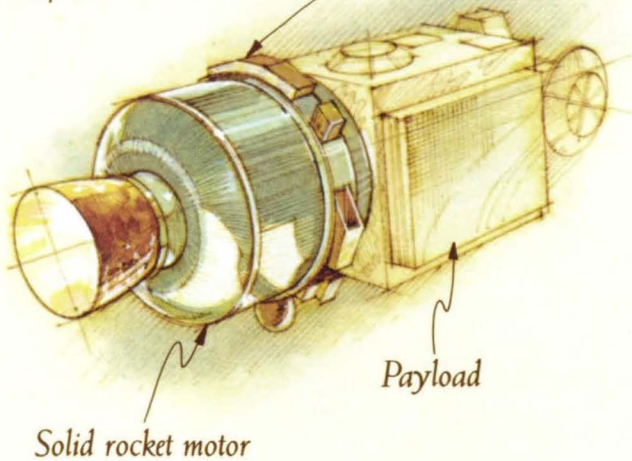
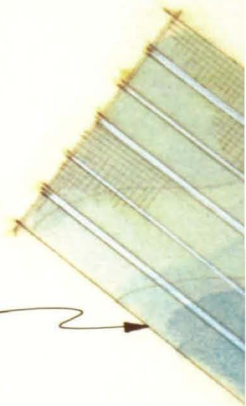

Transfer Orbit Stage (TOS)

The TOS will boost spacecraft and payloads from the Shuttle's low Earth orbit to geosynchronous transfer orbit.

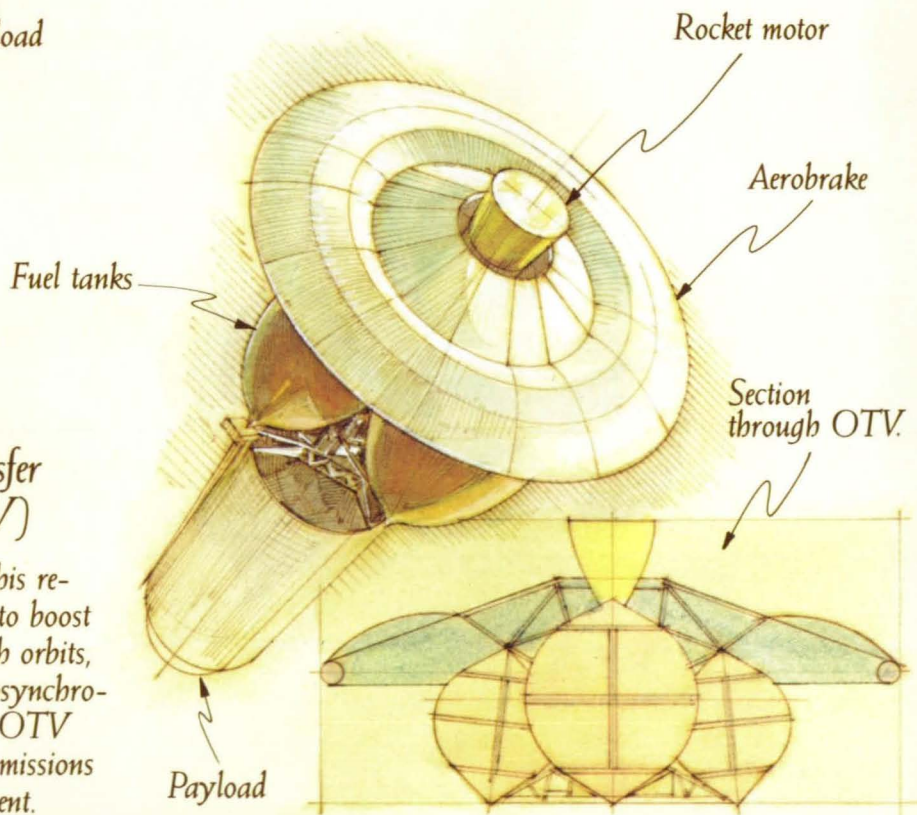

Orbital Transfer Vehicle (OTV)

The mission of this reusable vehicle is to boost spacecraft to high orbits, including the geosynchronous band. The OTV will fly 20 to 30 missions before refurbishment.

OUR COMMITMENT IS TOTAL. OUR CAPABILITIES

Propulsion unit

Astronomy payload

Manned
Maneuvering
Unit (MMU)

Living
quarters

Hand controller

For close proximity
operations, the MMU
will be used for
satellite servicing and
repair and in-space
construction.

Hangar

Earth observation
payloads

Permanently Manned Space Station

The basic space station will be assembled from hardware and modules carried in the cargo bay of the Space Shuttle on successive flights. Subsequent flights will ferry crews and supplies, and deploy independently orbiting platforms.

MARTIN MARIETTA

Martin Marietta Aerospace
6801 Rockledge Drive, Bethesda, Maryland 20817

ARE PROVEN. OUR MISSION IS SUCCESS.

Software that works



"At Vitro, we view software engineering as a discipline for improved productivity and quality. We recognize that rigorously applied formal methodologies and standards are essential to ensure software reliability."

*Frank Herman
Vitro Principal Software Engineer*

We develop it! Vitro Software Engineering

As Vitro's chief architect for standards and methodologies, Frank Herman helps make certain that our software products are a natural evolution of the engineering discipline.

Vitro develops software that works. Our engineered software satisfies your requirements. Quality software produced at Vitro must conform to explicitly documented specifications that ensure reliability, maintainability, testability, and correctness.

We apply an ordered approach to software engineering. This structured engineering approach for analysis, design, implementation, and testing provides you with visibility into all activities

of the software life cycle. The resultant products are engineered such that they can evolve to meet future demands.

Vitro's ongoing success as computer design agent for several major defense weapons systems enables us to offer our software engineering expertise for a broad range of other systems applications. Our extensive computer facilities, broad array of software development tools, and large staff of software engineers are available for your project.

Vitro Corporation stands ready to meet your software engineering needs...to continue a tradition of excellence.

Vitro *Turning Today's
Technologies
Into Tomorrow's Systems*
CORPORATION

14000 Georgia Avenue, Silver Spring, Maryland 20910
For information call our Marketing Manager, (301) 231-1300

A Unit of the Penn Central Federal Systems Company

Circle Reader Action No. 394



NASA Tech Briefs:

Published by:

Associated Business Publications
Editor-in-Chief/Publisher: **Bill Schnirring**
Managing Editor: **Rita Nothaft**
Associate Editor: **Judith Mann**
Assistant Editor: **Elena Nacanthor**
Technical Advisor: **Dr. Robert E. Waterman**
Creative Director: **Michael Renchiwich**
Art Director: **Melanie Gottlieb**
Production Manager: **Rita Nothaft**
Traffic Manager: **Karen Galindo**
Circulation Manager: **Anita Weissman**
Fulfillment Manager: **Elizabeth Kuzio**
Controller: **Neil B. Rose**

Technical Staff:

Briefs prepared for National Aeronautics and Space Administration by **Logical Technical Services Corp.**

Technical Editor: **Jay Kirschenbaum**
Art Director: **Ernest Gillespie**
Managing Editor: **Ted Selinsky**
Administrator: **Elizabeth Texeira**
Chief Copy Editor: **Pamela Touboul**
Staff Editors: **James Boyd, Theron Cole, Jr., Larry Grunberger, Jordan Randjelovich, George Watson**
Graphics: **Kenneth Blasko, Luis Martinez, Huburn Proffitt**
Editorial & Production: **Walter J. Pawlowski, Trudy Cavallo, Lorne Bullen, Frank Ponce, Joe Renzier, Ivonne Valdes**

NASA:

NASA Tech Briefs are provided by the National Aeronautics and Space Administration, Technology Transfer Division, Washington, DC:
Administrator: **James M. Beggs**
Acting Administrator: **Dr. William R. Graham**
Assistant Administrator for Commercial Programs: **Isaac T. Gillam IV**
Acting Director Technology Utilization Division: **Henry J. Clarks**
Publications Manager: **Leonard A. Ault.**

Associated Business Publications

41 East 42nd Street, Suite 921
New York, NY 10017-5391
(212) 490-3999
President: **Bill Schnirring**
Executive Vice President: **Frank Nothaft**
Vice President—Sales: **Wayne Pierce**
Vice President: **Patricia Neri**

Special Features and Departments

Editorial Notebook	6
Johnson: NASA's Center Stage	8
Letters	146
Advertising Index	147
About This Publication	148
Mission Accomplished	149

ON THE FRONT COVER:

Astronaut Bill Fisher trains for an extravehicular activity in the weightless environmental training facility (WET-F) at NASA's Johnson Space Center. The WET-F's neutral buoyancy simulates the conditions of weightlessness experienced by astronauts in space. For more on astronaut training, see "Johnson: NASA's Center Stage," which begins on page 8.

Advertising:

New York Office: (212) 490-3999
Vice President—Sales: **Wayne Pierce**
Sales Manager: **Robin DuCharme**
Account Executive: **Dick Soule**

Chicago Office: (312) 848-8144
Account Executive: **Irene Froehlich**

Los Angeles Office: (213) 477-5866
Account Executive: **Robert Bruder**

Technical Section Thumb Index

NASA TU Services	20	
New Product Ideas	26	
Electronic Components and Circuits	32	
Electronic Systems	56	
Physical Sciences	70	
Materials	80	
Life Sciences	90	
Mechanics	92	
Machinery	108	
Fabrication Technology	122	
Mathematics and Information Sciences	140	
Subject Index	142	

This document was prepared under the sponsorship of the National Aeronautics and Space Administration. Neither Associated Business Publications, Inc., nor anyone acting on behalf of Associated Business Publications, Inc., nor the United States Government nor any person acting on behalf of the United States Government assumes any liability resulting from the use of the information contained in this document, or warrants that such use will be free from privately owned rights. The U. S. Government does not endorse any commercial product, process, or activity identified in this publication.

NASA Tech Briefs, ISSN 0145-319X, copyright © 1986 in U.S., is published bi-monthly by Associated Business Publications, Inc., 41 E. 42nd St., New York, NY 10017-5391. The copyrighted information does not include the individual Tech Briefs which are supplied by NASA. Editorial, sales, production and circulation offices at 41 E. 42nd Street, New York, NY 10017-5391. Subscriptions for non-qualified subscribers in the U.S., Panama Canal Zone, and Puerto Rico, \$50.00 for 1 year; \$100.00 for 2 years; \$150 for 3 years. Single copies \$15.00. Remit by check, draft, postal or express orders. Other remittances at sender's risk. Address all communications for subscriptions or circulation to NASA Tech Briefs, 41 E. 42nd Street, New York, NY 10017-5391. Application to mail at second-class postage rates is pending at New York, NY 10017 and additional mailing offices.

POSTMASTER: please send address changes to NASA Tech Briefs, 41 E. 42nd Street, Suite 921, New York, NY 10017-5391.

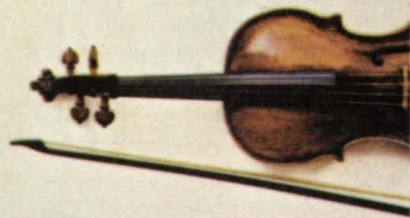
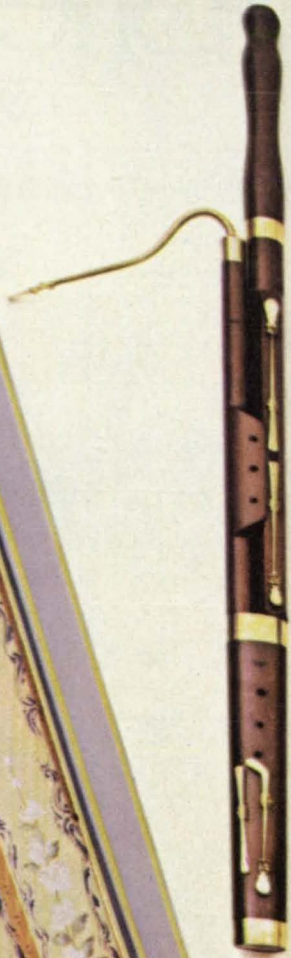



**For years baroque music was
composed without major change,
until J.S. Bach put these
instruments together in a way
that set him apart.**

All the baroque composers were faced with the same restrictions, the same notes, the same instruments, and the same musical forms. Yet today, we remember J.S. Bach above them all. Simply because he was able to arrange scores of music in a way no one had ever seen . . . or heard before.

At IBM Federal Systems Division we know that it takes the same degree of ingenuity to design and manage within the dimensions of today's complex systems programs. It's a special ability to combine a broad range of technology — and make it work together in harmony.

And we're doing exactly that for the National Aeronautics and Space Administration's Space Shuttle program.

We've orchestrated the operations of the most sophisticated flying vehicle ever built with a team of on-board computers. And we compose software that can be tuned for each mission to make space a more available resource.

In every project we undertake, we start with a myriad of individual parts, as separate as the notes of a scale. And put them into play—together. It isn't easy.

But the more complex the task, the more we manage to make it happen.



Federal Systems Division

Editorial Notebook

Picking Up the Pace

Beginning with this issue, *NASA Tech Briefs* becomes a bi-monthly magazine. You'll now be receiving six copies a year instead of the four you're used to receiving. There are several reasons for this, but the overriding one is the acceleration of technology transfer. As Robert A. Solo pointed out in testimony before the Senate Commerce Committee some years ago, "The value of information increases directly in proportion to the speed and breadth of its dissemination."

We've already increased the breadth of circulation... *NASA Tech Briefs* exceeds 100,000 circulation with this issue. Before we, the private publisher, joined NASA in this effort, the OMB-mandated circulation ceiling was 75,000. We have no circulation ceiling. Our goal is to ensure that *NTB* reaches every qualified reader who needs this information. We expect the increase in frequency will help address the other half of the equation that results in technology transfer.

The subject of technology transfer

continues to surface in ever-widening circles. President Reagan recently hosted a White House reception for participants in the National Initiative on Technology and the Disabled. The Initiative was created under the auspices of the Department of Health and Human Services to ensure that new and emerging medical technologies, many of which are spinoffs of NASA R&D, are made available to the people who need them. To this end, the Initiative established TECHNET, a national information network for disabled citizens, and TECHTEAM, a nationwide network of local technological professionals who are applying their skills, knowledge and talents to the problems of the disabled.

A different sort of technology transfer is taking place at NASA's Johnson Space Center, the subject of this issue's editorial feature. Agreements between Johnson and private companies provide for technical cooperation in a number of commercial space ventures, among them the Industrial Space Facility, which will be compati-



People transfer technology, and among those who do are (from left): Bill Chmylak, Technology Utilization Officer at Johnson Space Center; Isaac T. Gillam IV, NASA's Assistant Administrator for Commercial Programs; Bill Schnirring, NASA Tech Briefs Publisher; Gerald Griffin, Director of Johnson Space Center; Marvin Matthews, Patent Counsel at Johnson Space Center; and Len Ault, Deputy Director of NASA's Technology Utilization Division.

ble with Space Station, and a privately-financed upper stage booster.

For more on Johnson, turn the page, but before you do, best wishes for a happy new year from all of us at *NASA Tech Briefs*. We'll be working hard to make your publication the best it can be, and we appreciate all the feedback you've been giving us. Don't stop. □

Will your next proposal win...

Some of the world's most successful technology companies depend on us for their proposal needs. We supply top-caliber proposal consultants, engineers and writers in confidence. In a hurry. Anywhere in the free world. We cover every requirement put forth by government or utility RFP,

RFQ, IFB or Tender... in any advanced technology. Aerospace/Defense, Energy, Transportation. You name it, we've covered it. Successfully.

We increase your probability of winning—assisting or totally managing your proposal so that it's more responsive and better priced.



We develop strategy, organize and present in the latest proven formats a professional proposal. We speak well for your corporate interests through objectivity and planning. Our risk assessments, trade-off analyses, "devil's advocate" reviews and proper man-loading estimates fine-tune the technical/cost interaction so important to the competitive edge. We know proposals. And our experience gets results.

Pride, performance and hands-on professional presentation. **A-E Systems Management, Inc.**—the winning edge.



Proposal Management/Consulting
1089 West Granada Blvd., Suite II
Ormond Beach, FL 32074

Take a closer look. Call or write for a professional, non-obligatory critique of your existing proposal style or evaluation of your next RFP.

T.F. Visconti, President
Telephone (904) 673-4725
Telex 568899 (AESMI ORBH)

Product/Research Developments[®]

First of a series

General

This is presented in the interest of providing important new information that may help you do what needs to be done better and more efficiently.

Because the U.S. Government and the private sector have such different ways of doing business, 3M set up the Federal Systems Department nearly two years ago: To make it easy for you to take advantage of 3M's remarkable research and development capability, and to obtain the products you need from the 3M line of more than 40,000 diverse innovations.

Sixty-eight government contracts cover many of those products. So chances are whatever you need 3M has it.

The following summary information is provided to help you keep up-to-date on what is available to you and your organization from 3M... the company that hears you.

Over 20 megabyte capacity

With the increasing importance of personal computers in government, and with the corresponding need for greater data storage capacity, 3M has added to its line of data cartridge products one with a capacity of more than 20 megabytes.

Called 3M Brand DC 2000 Data Cartridge, this new development will be made available through contractors who are designing and producing personal computer drives.

Faster enlargement

Over the years, reduction of engineering drawings to 35mm microfilm aperture cards has proved convenient, efficient, and productive. For some applications, though, one of the difficulties was blowing back hard copies in quantity quickly enough during crisis situations.

Now a high-speed, dual-lens 3M printer can produce 600 quality prints per hour in sizes up to 18 x 24 inches on plain paper, vellum, or paper plates.

The dual lens permits instant switching from 10X to 14.5X magnification. Push-button controls, indicator lights, straight-through automatic card feeding, and design reliability make the *Quantimatic* Printer/Dual Lens a very important addition to large engineering operations.

(GS-00F-69684)

Static electricity detection

In many fields, such as electronics, printing, and the graphic arts, detection of static electricity before it becomes a problem is vitally important.

Now, thanks to 3M research and development, a small hand-held digital sensor can provide quick and easy detection and measurement of static electrical fields.

Official product name is 3M Model 709 Static Sensor.

Better pictures

Recent developments in 3M color photographic films for day-to-day and professional use provide faithful reproduction of original colors, including natural skin tones, with optimum brilliance and color saturation. Fine grain, very high edge sharpness, and high resolution are important characteristics.

Color print film comes in speeds of 100, 200, and 400. Slide film in 100, 400, and 1000. There is also a tungsten-balanced ISO 640 slide film.

Print 100 film is available in 120 width. All others are 35mm, in lengths for 12, 24, and 36 exposures, and also in 100-foot rolls.

(GS-00F-77267)

Improved communications

A whole new style of office communication has been created by *Post-it*[™] brand notes from 3M. Now it's easy to leave word anywhere, since the unique 3M adhesive sticks to almost anything—books, desks, calendars, newspapers, telephones, terminals, typewriters, doors—yet peels away easily, and can be repositioned somewhere else.

The result of many years of 3M research and development, the adhesive does not harden, weaken, or discolor with age, and will not build up on most materials. *Post-it* notes are available in a variety of sizes from small notes to mark pages or note corrections to large notes for important messages and attention-getting directions.

Also available in a full line of colors—yellow, green, white, blue, and pink. Custom imprinting is available, too.

Conclusion

For detailed information on these or any of the more than 40,000 products currently available from 3M, write or call toll-free 800-328-1684 (or in Minnesota 800-792-1072).

Literature and Federal Supply Schedule Price Lists will be mailed to you without cost or obligation. Or, if you wish, a 3M representative will call you for an appointment at your convenience to discuss your particular needs.

Just call **800-328-1684**

(In Minnesota 800-792-1072).

Post-it is a registered trademark of 3M.

Note: We currently have on hand a limited number of *reflective American flag stickers* which demonstrate the qualities of *Scotchlite*. Please call if you would like for us to send you one or more. (Available free of charge, while the supply lasts.)

Federal Systems Department/3M
1101 Fifteenth Street, N.W.
Washington, D.C. 20005

3M hears you...

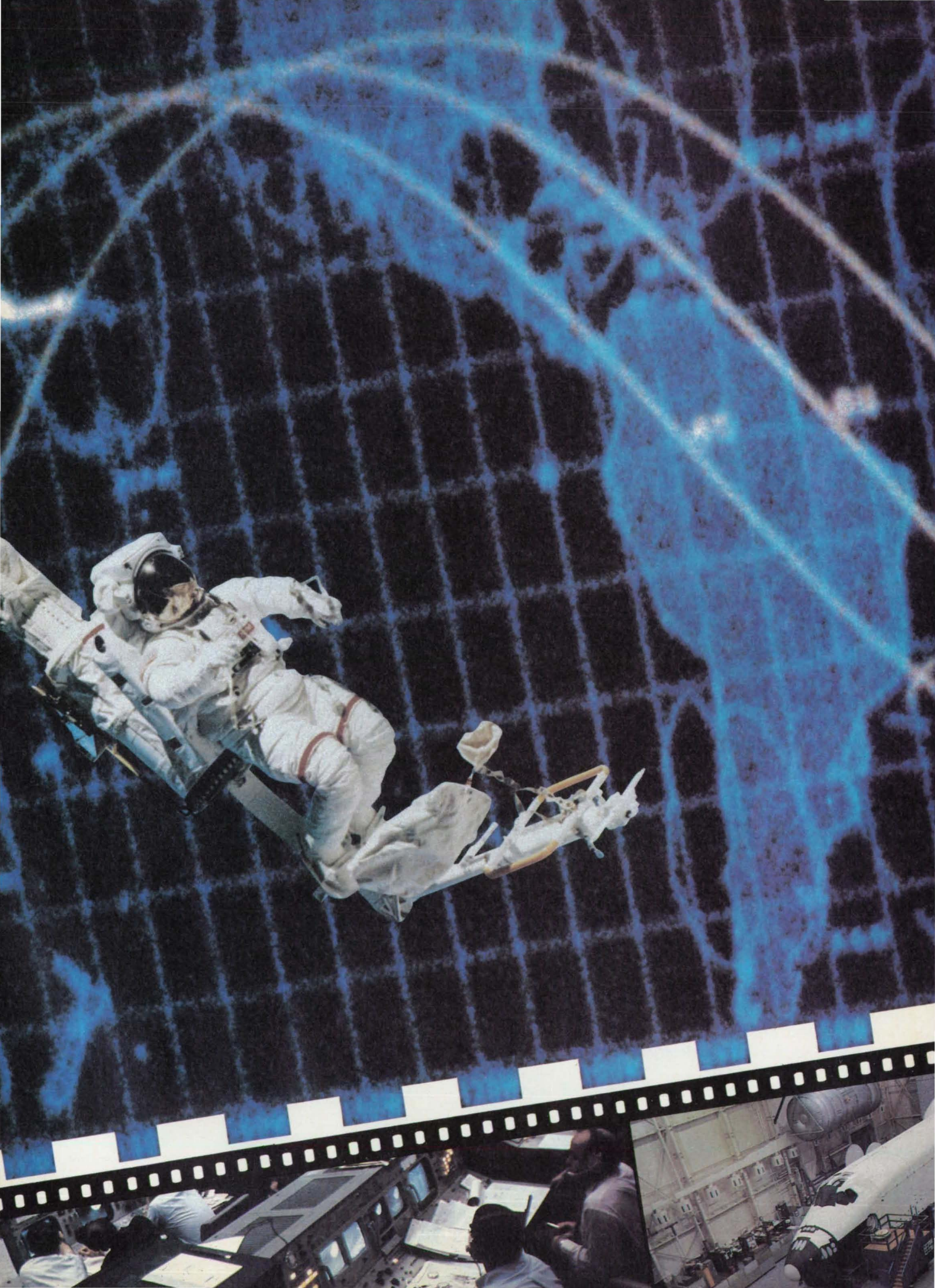



Johnson: NASA's Center Stage

If any one of NASA's nine field centers could be said to characterize the essence of the agency, that center would most likely be Johnson Space Center, at least as far as the public is concerned. And if one were to ask why, the answer might be simply: "astronauts." Either that or "mission control." Certainly it's the drama of humans venturing into space which has drawn public attention to the center, and much of the world has watched this drama unfold via the wide-angle lenses mounted in Johnson's building 30, the mission control center.

Johnson Space Center came into being just as America's manned spaceflight program got off the ground. Less than a month after Alan B. Shepard's historic suborbital flight aboard the Mercury capsule "Freedom 7," President John F. Kennedy proposed that the nation undertake the challenge of a manned lunar landing and safe return to earth, and accomplish it before the end of the 1960s.

The lunar commitment meant a number of things to NASA, among them the need for expanded operations and facilities. In September 1961, NASA administrator James E. Webb announced that a new Manned Spacecraft Center would be built on a 1620-acre prairie site, southeast of Houston, Texas. The new center would be the permanent home of the Space Task Group, the team of scientists, administrators and clerical personnel based at Langley Research Center in Hampton, Va., that had planned Project Mercury. The Manned Space-

The Emblem of an Era: The tracking screen at mission control is the backdrop for astronaut Bruce McCandless (left), who's attached to the shuttle remote manipulator system's mobile foot restraint, and the orbiter Columbia. Below (left to right): mission control operations during Apollo 10, shuttle mock-ups at Johnson Space Center, Skylab, and astronaut Bill Fisher underwater in Johnson's weightless environmental training facility.

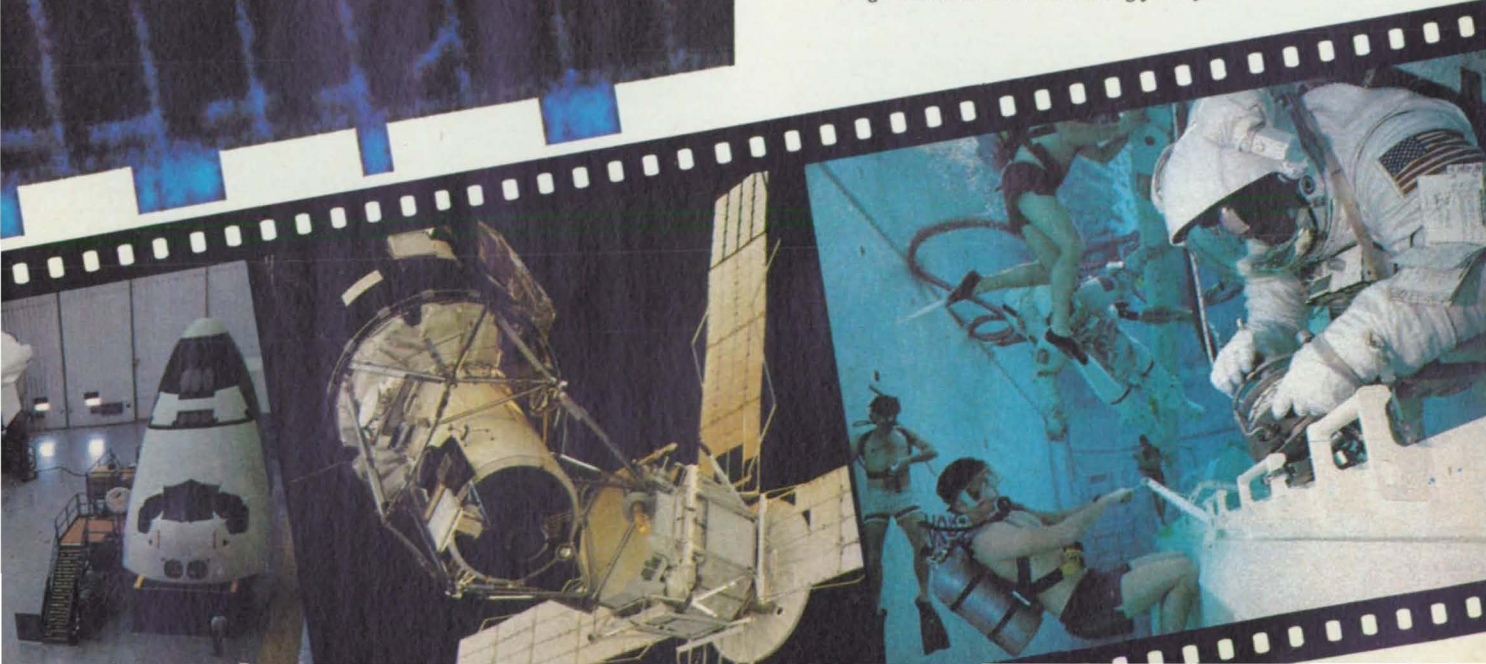

Johnson

craft Center, which was renamed the Lyndon B. Johnson Space Center in 1973, would be NASA's lead center for the design and development of manned spacecraft, the selection and training of astronauts, and the operational control of manned spaceflights.

Construction at the Houston site began in April 1962. Two years later, the first of the center's major buildings were ready for occupation, and in June 1965, those who monitored the course of the second manned Gemini mission did so from the vantage point of mission control.

Throughout the 1960s, as the drama, suspense and spectacle of the Apollo program unfolded, the Houston center played host to the hundreds of newspaper and television reporters who covered the space beat. Because reporters were not actually allowed inside mission control during the

course of spaceflights, television cameras and microphones were mounted inside the room to give reporters and the public access to history in the making. "One small step for man, one giant step for mankind" may be the most memorable words from the lunar surface, but they weren't the first. That distinction, and those words, "Houston, Tranquility Base here, the Eagle has landed," were directed to mission control, the heart of the Manned Spacecraft Center.

Heart and Soul

If mission control is at the heart of Johnson Space Center, then the astronauts are close to its soul. Everyone from the "original 7" Mercury astronauts to the burgeoning corps of shuttle commanders, pilots, mission and payload specialists has spent a good deal of time in Houston, whether going through the selection process or training for missions.

On Becoming an Astronaut

Astronauts are made, not born, so becoming one in the '80s is as much a matter of the right credentials as the "right stuff." To be eligible to apply to the program, would-be astronauts must meet minimum educational and physical requirements. These differ somewhat, depending on whether one wishes to apply as a pilot astronaut or as a mission specialist. (Pilot astronauts fly the shuttle, while mission specialists manage shuttle systems and operate the payloads and experiments during flight.) In either case, applicants must hold a bachelor's degree in engineering, biological or physical sciences, or mathematics.

An advanced degree and/or equivalent professional experience are desirable for pilot astronauts, and required for mission specialists. Further, pilot applicants must have logged at least 1,000 pilot-in-command hours in jet aircraft, and both groups must be able to pass stringent NASA space flight physicals, which place special emphasis on visual acuity, hearing, and blood pressure. Finally, pilot applicants must be between 64 and 76 inches tall, while mission specialists must be between 60 and 70 inches.

Through its astronaut selection office at Johnson Space Center, NASA accepts applications from civilians on a continuing basis (military applicants apply through their branch of the armed services). After reviewing the applications, NASA develops a selection roster, and invites the highest-ranking applicants to Johnson for interviews and medical evaluations. Based on upcoming mission requirements and the astronaut corps' rate of attrition, NASA selects a number of astronaut candidates annually.

The most recent group of 13 astronaut candidates was selected last June from a roster of 33 civilian applicants and 133 military nominees. Of these, 59 were interviewed at Johnson and, finally, five civilian and eight military candidates were selected. They reported to Johnson late last summer to begin a year-long period of training and evaluation, at the end of which they'll become full-fledged astronauts, ready for assignment to a shuttle crew.

The new candidates join NASA's current corps of 90 flight-status astronauts. In all, 157 persons have been named astronauts since the program began in 1959 with the selection of the "original 7," the founders of that illustrious order which turns qualified earthlings into space travelers. □

An astronaut information and application packet may be obtained by writing to: Johnson Space Center, Astronaut Selection Office, Attn: AHX, Houston, TX 77058.



The "original 7" Mercury astronauts.

Astronaut training is conducted under the auspices of Johnson's space operations directorate. Full-scale mock-ups of the shuttle itself are located in building 9A, and a variety of systems and mission simulators, complete with windows on which actual space scenes are projected, are in building 5. Here the shuttle astronauts familiarize themselves with orbiter hardware and software, much as those who came before them did with Gemini, Apollo and Skylab mock-ups and simulators.

The focus of the training program is routine—with a capital "R." Astronauts perform the tasks necessary to successful spaceflight again and again and again. Every imaginable "what if...?" is thrown into play, so that by the time a mission is ready for launch, a bare minimum of the unexpected is left to expect.

Time-lines are established as the crew becomes more and more proficient at performing its tasks, and these are used in mission planning—determining its duration and scheduling the sequence of on-orbit activities. A full dress rehearsal, involving both shuttle crew and simulators, and ground crew, tracking stations and mission control precedes every spaceflight.

Flights aboard NASA's KC-135 aircraft serve to familiarize astronauts with the experience of weightlessness. The KC-135's pilot flies a parabolic curve flight profile, exposing astronauts to a brief period of zero-gravity, during which they become accustomed to weightlessness and practice tasks such as spacesuit donning.

Those astronauts who will be performing extravehicular activities (EVAs) receive additional training in Johnson's weightless environment training facility—the WET-F. Astronauts don their bulky extravehicular mobility and manned maneuvering units before being lowered into a 25-foot deep "swimming pool." A full-scale mock-up of the shuttle's cargo bay rests at the bottom of the neutral buoyancy WET-F. There the astronauts, monitored for safety by trained scuba divers, learn to perform the maneuvers and tasks, such as tending experiments and deploying satellites, that they'll repeat in space during the actual EVA.

Behind the Scenes

While much of the public's attention focuses on astronauts and shuttle missions, much of the activity at Johnson Space Center focuses on the research and engineering which support continued operation and improved performance of the shuttle program. Johnson's research and engineering directorate is divided into two major organizations: space and life sciences, and engineering.

Space and life sciences includes a space bio-medical research institute, which conducts research into the impact of space travel on human physiology. Space adaptation syndrome, otherwise known as space motion sickness, is one area where researchers are concentrating. (Roughly ▶

IF ONLY, MR. EDISON



...had gone through magnetic design analysis of his phonograph with the AOS/MAGNETIC™ Analysis Program. He could have learned its optimum electrical efficiency and cost effectiveness without making costly physical prototypes.

Dogs have a lot going for them, but the AOS/MAGNETIC Analysis Program is a more reliable check for quality and design integrity.

Imagine how the AOS/MAGNETIC Analysis Program would have helped Mr. Edison design the most efficient phonograph faster and with a lot less cost.

While you're chatting, ask our representative to deliver a poster of Edison at work suitable for hanging in your office. Edison invented the phonograph in 1878 as a toy for his three children. The first recorded phonograph message was "Mary had a little lamb."

It may be too late for Mr. Edison, but not for you to vastly improve your designs by using the AOS/MAGNETIC Analysis Program. You only need to call us and we'll show you how we can help you look great while we save you money.

CALL US AT

1-800-MAG-6442



A.O. SMITH
DATA SYSTEMS, INC.

A SUBSIDIARY OF A. O. SMITH CORPORATION
8901 N. Kildeer Ct., • Milwaukee, WI 53209

In 1992, we set sail for a New World.

In 1492, a Genoese navigator and an intrepid crew crossed uncharted waters in search of a west passage to India. In the process, they uncovered the vast resources of two continents. And they opened up a new base for exploration, progress, and the hopes of mankind.

In 1992, coincident with the 500th anniversary of Columbus's voyage, we plan to set sail for another New World. That year, or shortly thereafter, the United States and the world will begin benefiting from the first manned Space Station. The Station will be more than another giant step for mankind. It will be our stepping stone to living in new realms, and it will result in thousands of discoveries that will benefit earth.

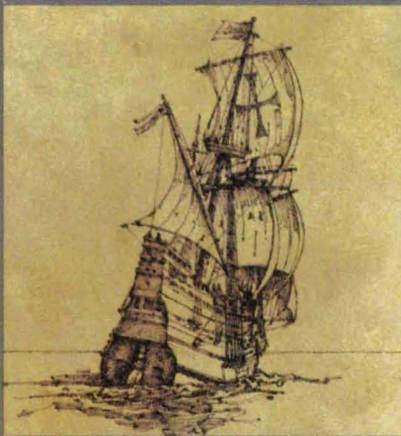

This New World, free from gravity and atmospheric impurity, will provide that ideal environment for experimentation and production that is impossible on earth. Simultaneously we will have a permanent station for scanning the earth and the heavens — an unparalleled vantage point for predicting weather, aiding agriculture, and understanding the universe.

Of course, like Columbus, we cannot foresee all the benefits ahead. But we do know that we will have a new arena in which to conquer disease, transform the materials of earth, and generate precious energy. The resulting knowledge from countless discoveries will come down to earth for our well-being.

But, unlike Columbus, our craft will be in constant contact with the Old World. Harris Aerospace, as a member of the Rockwell, Grumman and Sperry team, is responsible for the Space Station's communications and tracking system. We are totally committed to this great endeavor, and we bring to the challenge the capabilities and experience necessary for success.

Harris has had 27 years of successful involvement with the kind of space communications and tracking required for the manned Space Station. Our space experience includes programs from Telstar to the Tracking and Data Relay Satellite as well as the manned programs of Apollo, Lunar Module, and Space Shuttle. We are also a leader in the architecture and design of large communication networks.

Now Harris is ready for the Space Station. Over the next years and centuries, the scope of scientific, commercial and technological opportunities and breadth of results are sure to exceed our wildest expectations.

For in 1992, we, too, will be very much like Columbus: carrying the sum of our knowledge into the unknown. And, like him, we, too, shall return with the bountiful gifts of a New World.



HARRIS

Circle Reader Action No. 410

For your information,



our name is Harris.

Johnson

50% of the people who fly in space experience some symptoms of space motion sickness during the first three to four days of spaceflight.) At present, there appears to be no clear correlation between space motion sickness and its earthly counterpart. Astronauts who experience motion sickness during ground tests are often free of its effects while in space, and those who experience space motion sickness are often immune to the effects of the ground tests, some of which employ a rotating chair. Johnson bio-medical researchers are working on various techniques, which range from drugs to bio-feedback, to control the effects of space motion sickness while they continue to search for its cause.

Other researchers at Johnson's space bio-medical institute focus on calcium loss during prolonged spaceflight. This work is a carryover from the mid-1970s, when Skylab astronauts who remained in space for 84 days experienced a 10% loss of bone calcium. NASA's plans for a permanently manned space station make this research increasingly relevant, since space station crews will be likely to stay in space for months at a time.

In addition to the space bio-medical research institute, the medical sciences and life science projects divisions also come under the auspices of the space and life sciences organization. Medical sciences does the operational medicine for shuttle crews, while life sciences is preparing for Johnson's first Spacelab mission, which will fly later this year. Spacelab, a joint program involving NASA and the European Space Agency (ESA), provides versatile laboratory facilities that accommodate a variety of scientific experiments, many of which are extensions of Skylab research. While previous Spacelab missions have focused on scientific investigations into solar, atmospheric and plasma physics, and materials science in a microgravity environment, the Johnson-managed Spacelab 4 will be largely a life sciences mission.

Three other programs complete the space and life sciences organization. The solar system exploration division is a carryover from the Apollo era, and researchers there continue to analyze lunar materials and meteorites, in addition to space debris.

The man-systems division explores man-machine relationships and how these relationships change in the space environment. Man-systems personnel develop meal plans and procedures for spaceflights, and determine what sorts of food preparation techniques are best-suited to the limited capabilities of the shuttle galley. They also develop other habitability-related equipment, such as zero-gravity showers and sleeping restraints. This division, in-

identally, also maintains the crew training equipment, such as the mock-ups and the WET-F, and man-systems personnel use them in developing the training procedures which are later taught to astronauts. Finally, an artificial intelligence and information sciences office completes the space and life sciences directorate.

Working Together

Johnson's space and life sciences programs are closely allied with its space operations directorate, especially where crew training and crew systems are concerned. Similarly, Johnson's engineering directorate supports space operations in a variety of ways.

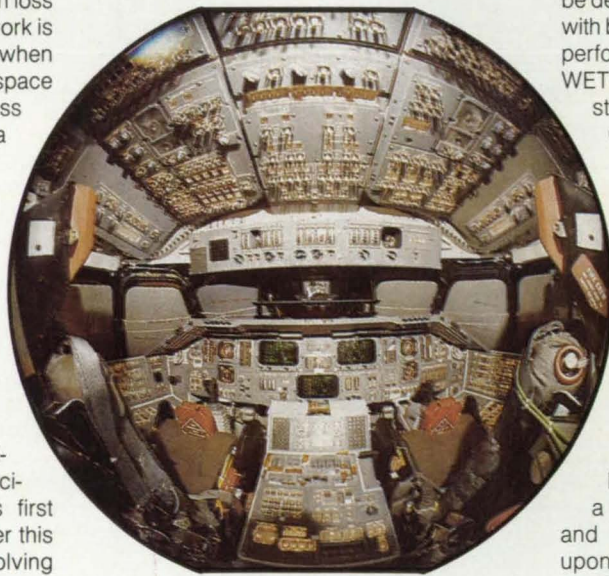

A "fisheye" view of the space shuttle procedures simulator.

The engineering directorate consists of several divisions, each of which tends to focus on a specific engineering discipline or spaceflight system. The crew systems division, for example, develops life support systems, environmental controls, space-suits and the manned maneuvering unit (MMU), a powered backpack which propels astronauts during EVAs. The propulsion and power division works with devices such as fuel cells, batteries and auxiliary power units which fly onboard the shuttle. The cargo integration office is concerned with systems which secure payloads in the shuttle cargo bay, and the tracking and communications division provides the systems needed to communicate with the earth and with other spacecraft.

The structures and mechanics division focuses on the materials and mechanical systems that, together, form a spacecraft, while the avionics system division manages all the hardware and software that

combine to create the shuttle's data management avionics system. The simulation and avionics integration division is involved in some crew training, and in evaluating the performance of shuttle systems, such as the remote manipulator arm and shuttle avionics—how the orbiter flies.

Essentially, Johnson's engineering organization is devoted to maintaining cost-effective and routine operational status for the space shuttle. Its tasks range from fixing the brakes on the orbiter to handling problems which arise during the course of actual shuttle flights. Often, new systems and/or procedures must be developed literally overnight, when an on-orbit malfunction or failure occurs. An example of this sort of contingency action might be a satellite that fails to activate following deployment from the shuttle. A device for triggering the satellite's power system will be developed at Houston. Then it is tested with back-up hardware, and simulations are performed in both the mock-ups and the WET-F to develop procedures for constructing the device and for using it. Once established, these procedures are transmitted to the shuttle crew for use in the actual attempt to activate the satellite.

Gearing Up

Now that the space shuttle has achieved routine operational capability, the focus of activity at Johnson Space Center has begun to shift. In his 1984 State of the Union Address, President Reagan called upon NASA to develop a permanently manned space station, and NASA, shortly thereafter, called upon Johnson to act as lead center for the new project. NASA-sponsored industry studies yielded a number of design alternatives during 1984-85. These are currently being considered at Johnson, which is responsible for the design and development of space station's structural framework. A definitive design will be established during 1986-1987.

Johnson engineers will be designing and developing space station's thermal and attitude control systems, and its communications and data management systems. The integration and installation of these and other systems into space station's overall structure will be managed by Johnson as well.

Johnson's space station program office is helping to coordinate the work of the other NASA field centers, specifically Goddard, Marshall and Lewis, which are handling three of the four work packages which comprise space station.

Johnson has established a space station systems engineering office to initiate design and development work on space station systems. With a tentative launch date of 1992—the 500th anniversary of the voyage of Columbus—it's to be expected

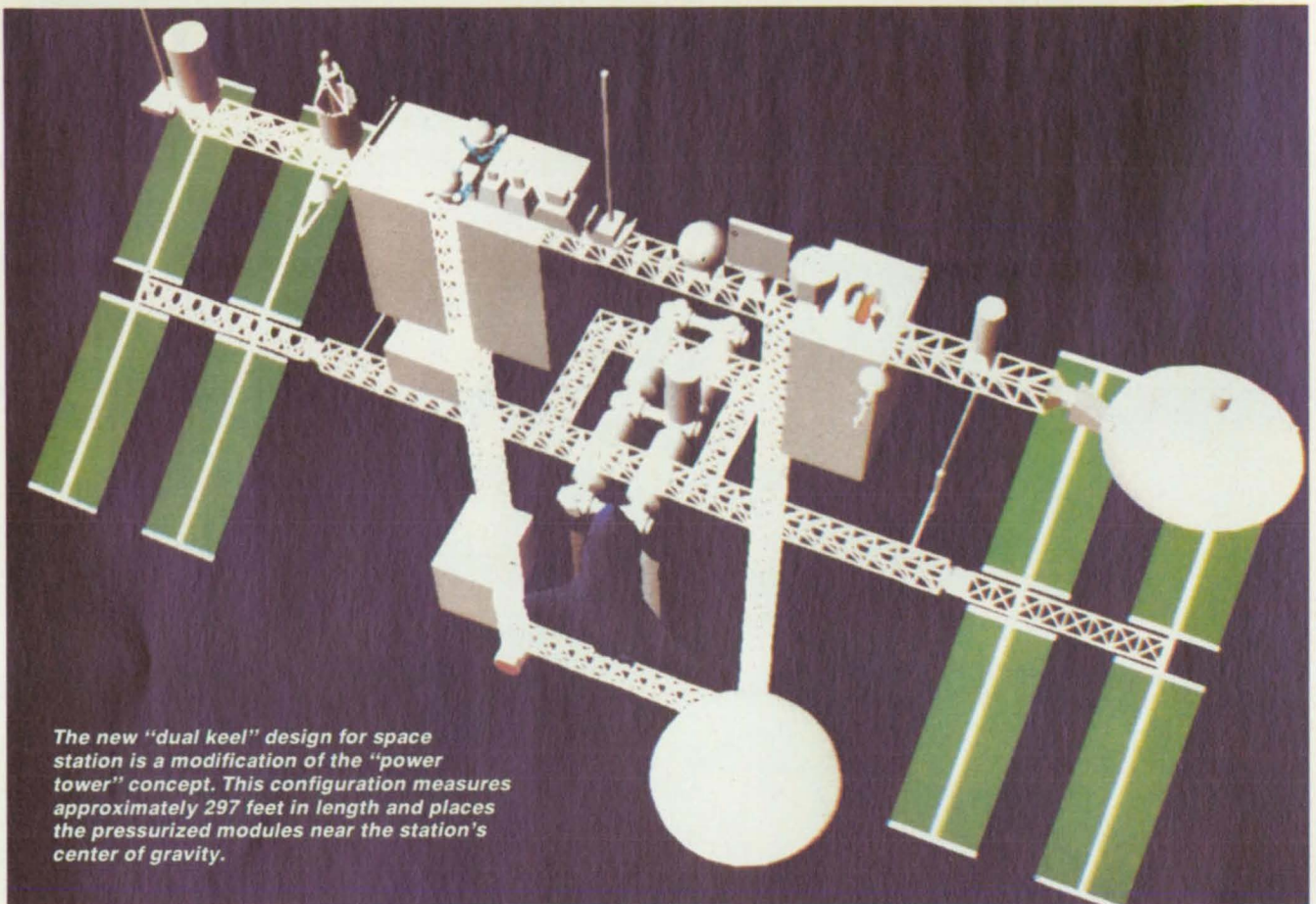

The new "dual keel" design for space station is a modification of the "power tower" concept. This configuration measures approximately 297 feet in length and places the pressurized modules near the station's center of gravity.

Johnson

that this inaugural engineering work will begin spilling over into the other engineering offices. Yet, since an operational space shuttle program is germane to the concept of space station, sustaining work in this area will continue and, no doubt, modifications designed to accommodate the particular needs of space station will be developed and incorporated.

As space station moves from the drawing board toward the launchpad, it opens up a new and expansive realm of possibilities for continuing the human venture into space. Johnson's advanced programs office is studying the feasibility of a number of projects which use space station as a point of departure, among them a lunar base and a manned expedition to Mars. While plans to go ahead with these programs have not yet been made, the fact that they exist as feasibilities should be exciting to everyone who looks forward to the continued exploration of space.

Coming of Age

Now that the frenzy of media activity which surrounded the Apollo program has abated, it's often difficult to get information on exactly what's happening with the American space program. The routine launches and landings of the shuttle probably help to create the impression that

space just isn't as exciting a topic as it used to be. Behind this somewhat superficial perception of the current American space program is a fundamental change in the way NASA manages its manned space-flight programs. Joseph P. Loftus, assistant director in charge of plans at Johnson Space Center, characterizes the change as follows:

"If you hark back to the '60s, we did things all under the banner of a mission. So you had Apollo, whose mission was to land on the moon, and Viking, a mission to Mars, and so forth. What's going on now is we are passing through a major watershed. We are uncoupling facilities and capability from the mission. The shuttle doesn't have a mission; it has a capability and it flies missions. The space station doesn't have a mission; it is a facility which will accommodate many, many mission objectives. I think that makes for a very significant change in the character of activities in an organization, when you go from very explicit mission objectives, with everything in effect custom-designed, to this different world of capabilities.

"What we're trying to put in place is a space operations system, of which the shuttle is the part that gives us access to low-earth orbit, return from orbit, recovery, retrieval, sorties, and then the space station is an extension of that capability. It gives us permanency, a locus where we can have a depot, so we no longer have to take things back and forth. We can accumulate things on-orbit. That's a very large increase

in the efficiency of activity. And then, of course, once you get that, there is a natural correlary which says you can begin to expand space-base activities, so that you can assemble things on orbit, and you can have your higher energy transportation systems based in space, rather than based on earth. Once you have those elements in place, you have a basic operations infrastructure, with which you can do whatever it is that seems appropriate or attractive."

As NASA moves into the '90s, its facilities and capabilities will continue to expand and mature. At the same time, new facilities and capabilities will emerge—witness the recent West German Spacelab mission. Payload monitoring and management was conducted at the West German Space Operations Center in Oberpfaffenhofen, West Germany. Space station will help to expand this user community by offering a permanent presence in space for private industry and research. Further, agreements between NASA and the European, Canadian and Japanese space agencies will give space station an international aspect.

Even in the midst of this diversification, Johnson Space Center will retain a starring role in the burgeoning space enterprise. As lead center for space station, Johnson will focus both the domestic and international efforts which support the program. And when space station becomes operational in the early 1990s, the world will see what there is to see through those same wide-angle lenses at mission control. □

Here's one supermini that's

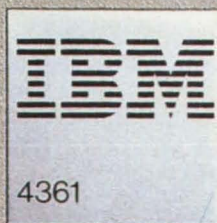

gonna knock your socks off.

It's the IBM 4361.

And it's setting new standards for cost-performance. IBM? Supermini? For computational processing? You bet. It'll knock the socks off a centipede.

Speed. The 4361 features a high-speed cache buffer. It has a separate floating-point processor to handle multiplication. And it executes the 70 most-used instructions in the hardware. No wonder the 4361 will turn in a Whetstone that will knock your.... You get the idea.

Precision and accuracy. The 4361 has advanced 32/64-bit architecture. It can handle 31-decimal-digit precision. And as for accuracy, IBM's high-accuracy arithmetic facility (ACRITH) includes 22 special floating-point instructions that can be used to process iterative calculations accurately. The ACRITH program notifies you if the accuracy you need can't be maintained.

Ease of use. The 4361 needs no pampering. Install it almost anywhere—in a corner of your office, for example. And the 4361 can run unattended, with no onsite DP specialist.

To make life easier yet, there's the IBM Engineering/Scientific Support System (E/S³)—a consistent, menu-driven interface for interactive users. E/S³ is rich in function and offers an open architecture so you can add applications easily. It handles graphics, text and data manipulation. And it supports a wide range of administrative applications.

Attachability. What would you like to attach to your IBM 4361? Lab instruments? Personal computers? ASCII-oriented devices? Are they Multibus* or Unibus** -oriented? Or do they use a serial digital interface? The 4361 welcomes them all. It attaches to IBM and non-IBM devices of all kinds.

Growth path. The 4361 protects your investment. It can be upgraded on your premises over a processing power range of three to one. At low cost and in small steps. If you out-grow even the biggest 4361, you can move up to the IBM 4381 or one of the large 308X or 3090 processors.

There's much, much more. In technology, architecture, service and support. The 4361 is an engineering/scientific computer from head to toe. But hold our feet to the fire. Demand answers to all your questions.

To receive brochures on the 4361 and E/S³, or to have an IBM marketing representative call, return the coupon.



*Multibus is a trademark of Intel Corporation. **Unibus is a trademark of Digital Equipment Corporation.

IBM DRM Dept. LQ/710 101 Paragon Drive Montvale, NJ 07645	1-86
<input type="checkbox"/> Please send me information on the IBM 4361 supermini and E/S ³ .	
<input type="checkbox"/> Please have an IBM marketing representative call.	
Name _____	
Title _____	
Company _____	
Address _____	
City _____ State _____ Zip _____	
Phone _____	

SYSTEMS INTEGRATION OF MIXING APPLICATIONS



TION: THE SCIENCE S AND ORANGES

We've been doing it successfully for over 15 years

Grumman Data Systems approaches information processing problems with a single goal: to develop integrated systems that deliver the best performance at the lowest life-cycle cost, while remaining as simple and user-friendly as state-of-the-art technology allows.

It's a difficult task, at best. But it's one to which we bring years of experience, and the objective viewpoint that only a hardware-independent system integrator can provide.

In C³I systems, management information systems, computerized test systems, engineering and scientific systems, and integrated manufacturing systems, we've built a record of success that any company would envy.

To maintain that record, we've invested substantially in research and

development. That's why our name is so often linked to new advances in networking, computer graphics, machine intelligence, command support systems, fault tolerant systems and the Ada software language.

We're also a total service company, not one that simply installs a system and walks away. We have facilities nationwide. And we support our customers with information processing services, multi-vendor hardware and software maintenance, training, data base publishing and facilities management.

Our ability to effectively mix apples and oranges has made us the fastest growing division of the Grumman Corporation. For further information about any of our capabilities, contact Wesley R. Stout, Director, Technical Services at (516) 682-8500.

CUSTOM SOLUTIONS
for Managing Information

Grumman Data Systems

Circle Reader Action No. 363

* A registered trademark of Grumman Corporation

GRUMMAN*

NASA Technology Utilization Services

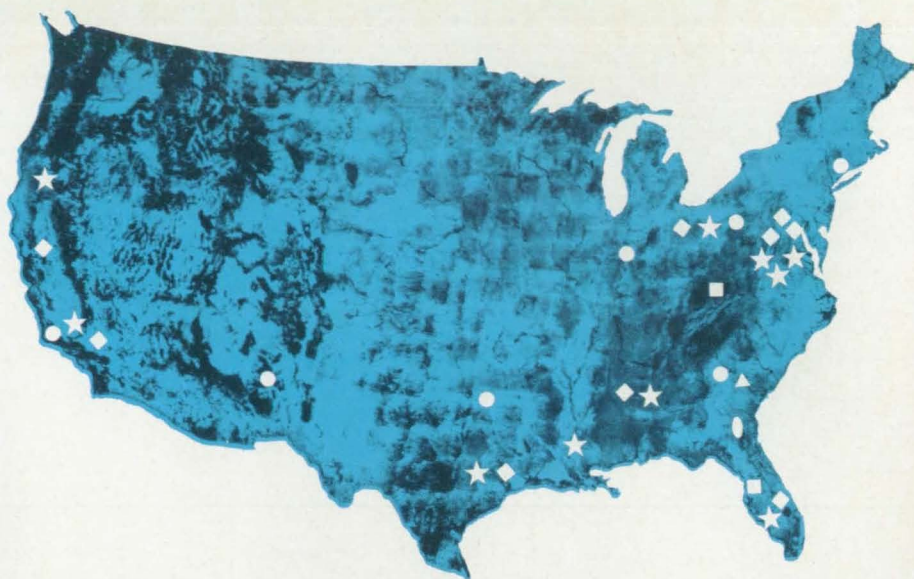
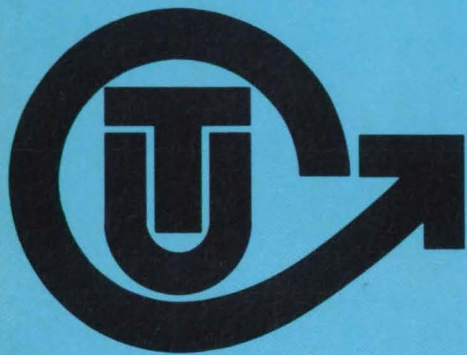

TECHNOLOGY UTILIZATION OFFICERS

Technology transfer experts can help you apply the innovations in NASA Tech Briefs.

The Technology Utilization Officer

at each NASA Field Center is an applications engineer who can help you make use of new technology developed at his center. He brings you NASA Tech Briefs and other special publications, sponsors conferences, and arranges for expert assistance in solving technical problems.

Technical assistance,

in the form of further information about NASA innovations and technology, is one of the services available from the TUO. Together with NASA scientists and engineers, he can often help you find and implement NASA technology to meet your specific needs.

Technical Support Packages (TSP's)

are prepared by the center TUO's. They provide further technical details for articles in NASA Tech Briefs. This additional material can help you evaluate and use NASA technology. You may receive most TSP's free of charge by using the TSP Request Card found at the back of this issue.

Technical questions about articles

in NASA Tech Briefs are answered in the TSP's. When no TSP is available, or you have further questions, contact the Technology Utilization Officer at the center that sponsored the research [see facing page for details].



COSMIC®

An economical source of computer programs developed by NASA and other government agencies.

A vast software library

is maintained by COSMIC—the Computer Software Management and Information Center. COSMIC gives you access to approximately 1,600 computer programs developed for NASA and the Department of Defense and selected programs for other government agencies. Programs and documentation are available at reasonable cost.

Available programs

range from management (PERT scheduling) to information science (retrieval systems) and computer operations (hardware and software). Hundreds of engineering programs perform such tasks as structural analysis, electronic circuit design, chemical analysis, and the design of fluid systems. Others determine building energy requirements and optimize mineral exploration.

COSMIC services

go beyond the collection and storage of software packages. Programs are checked for completeness; special announcements and an indexed software catalog are prepared; and programs are reproduced for distribution. Customers are helped to identify their software needs; and COSMIC follows up to determine the successes and problems and to provide updates and error corrections. In some cases, NASA engineers can offer guidance to users in installing or running a program.

Information about programs

described in NASA Tech Briefs articles can be obtained by circling the appropriate number on the TSP request card at the back of this issue.



★ TECHNOLOGY UTILIZATION OFFICERS

Stanley A. Miller
Ames Research Center
 Mail Code 234-2
 Moffett Field, CA 94035
 (415) 694-6472

Donald S. Friedman
Goddard Space Flight Center
 Mail Code 702.1
 Greenbelt, MD 20771
 (301) 344-6242

William Chmylak
Lyndon B. Johnson Space Center
 Mail Code AL32
 Houston, TX 77058
 (713) 483-3809

U. Reed Barnett
John F. Kennedy Space Center
 Mail Stop: PT-TPO-A
 Kennedy Space Center, FL 32899
 (305) 867-3017

John Samos
Langley Research Center
 Mail Stop 139A
 Hampton, VA 23665
 (804) 865-3281

Daniel G. Soltis
Lewis Research Center
 Mail Stop 7-3
 21000 Brookpark Road
 Cleveland, OH 44135
 (216) 433-4000, Ext. 422

Ismail Akbay
George C. Marshall Space Flight Center
 Code AT01
 Marshall Space Flight Center,
 AL 35812
 (205) 453-2223

Leonard A. Ault
NASA Headquarters
 Code IU
 Washington, DC 20546
 (202) 453-1920

Norman L. Chalfin
Jet Propulsion Laboratory
 Mail Stop 201-110
 4800 Oak Grove Drive
 Pasadena, CA 91109
 (818) 354-2240

Robert M. Barlow
National Space Technology Laboratories
 Code GA-10
 NSTL Station, MS 39529
 (601) 688-1929

Gordon S. Chapman
NASA Resident Office-JPL
 Mail Stop 180-801
 4800 Oak Grove Drive
 Pasadena, CA 91109
 (818) 354-4849

● INDUSTRIAL APPLICATIONS CENTER

Aerospace Research Applications Center (ARAC)
 Indianapolis Center for Advanced Research

611 N. Capitol Avenue
 Indianapolis, IN 46204
 John M. Ulrich, Director
 (317) 262-5003

Kerr Industrial Applications Center (KIAC)
 Southeastern Oklahoma State University
 Station A, Box 2584
 Durant, OK 74701
 Tom J. McRorey, Director
 (405) 924-6822

NASA Industrial Applications Center
 823 William Pitt Union
 University of Pittsburgh
 Pittsburgh, PA 15260
 Paul A. McWilliams, Executive Director
 (412) 624-5211

NERAC, Inc.
 Mansfield Professional Park
 Storrs, CT 06268
 Daniel U. Wilde, President
 (203) 429-3000

North Carolina Science and Technology Research Center (NC/STRC)
 Post Office Box 12235
 Research Triangle Park, NC 27709
 James E. Vann, Director
 (919) 549-0671

Technology Application Center (TAC)
 University of New Mexico
 Albuquerque, NM 87131
 Stanley A. Morain, Director
 (505) 277-3622

NASA Industrial Applications Center (WESRAC)
 University of Southern California
 Research Annex
 3716 South Hope Street
 Room 200
 Los Angeles, CA 90007
 Robert Mixer, Director
 (213) 743-6132

◆ PATENT COUNSELS

Robert F. Kempf, Asst. Gen.
 Counsel for Patent Matters
NASA Headquarters
 Code GP
 Washington, DC 20546
 (202) 453-2424

Darrell G. Brekke
Ames Research Center
 Mail Code: 200-11A
 Moffett Field, CA 94035
 (415) 694-5104

John O. Tresansky
Goddard Space Flight Center
 Mail Code: 204
 Greenbelt, MD 20771
 (301) 344-7351

Marvin F. Matthews
Lyndon B. Johnson Space Center
 Mail Code: AL3
 Houston, TX 77058
 (713) 483-4871

James O. Harrell
John F. Kennedy Space Center
 Mail Code: PT-PAT
 Kennedy Space Center, FL 32899
 (305) 867-2544

Howard J. Osborn
Langley Research Center
 Mail Code: 279
 Hampton, VA 23665
 (804) 865-3725

Gene E. Shook
Lewis Research Center
 Mail Code: 60-2
 21000 Brookpark Road
 Cleveland, OH 44135
 (216) 433-5753

Leon D. Wofford, Jr.
George C. Marshall Space Flight Center
 Mail Code: CC01
 Marshall Space Flight Center, AL
 35812
 (205) 453-0020

Paul F. McCaul
NASA Resident Office-JPL
 Mail Code: 180-801
 4800 Oak Grove Drive
 Pasadena, CA 91109
 (818) 354-2734

□ APPLICATION TEAM

Technology Application Team
Research Triangle Institute
 Post Office Box 12194
 Research Triangle Park, NC 27709
 Doris Rouse, Director
 (919) 541-6980

■ STATE TECHNOLOGY APPLICATIONS CENTERS

NASA/Southern Technology Applications Center
 State University System of Florida
 307 Weil Hall
 Gainesville, FL 32611
 J. Ronald Thornton, Director
 (904) 392-6760

NASA/UK Technology Applications Program
 University of Kentucky
 109 Kinkead Hall
 Lexington, KY 40506-0057
 William R. Strong, Program Director
 (606) 257-6322

● COMPUTER SOFTWARE MANAGEMENT & INFORMATION CENTER

COSMIC®
 Computer Services Annex
 University of Georgia
 Athens, GA 30602
 John A. Gibson, Director
 (404) 542-3265

● CENTRALIZED TECHNICAL SERVICES GROUP

NASA Scientific and Technical Information Facility
 Technology Utilization Office
 P.O. Box 8757
 BWI Airport, MD 21240
 Walter M. Heiland, Manager
 (301) 859-5300, Ext. 242, 243

STATE TECHNOLOGY APPLICATIONS CENTERS

Technical information services for industry and state and local government agencies

Government and private industry in Florida and Kentucky can utilize the services of NASA's State Technology Applications Centers (STAC's). The STAC's differ from the Industrial Applications Centers described on page 21, primarily in that they are integrated into existing state technical assistance programs and serve

only the host state, whereas the IAC's serve multistate regions.

Many data bases, including the NASA base and several commercial bases, are available for automatic data retrieval through the STAC's. Other services such as document retrieval and

special searches are also provided. (Like the IAC's, the STAC's normally charge a fee for their services.)

To obtain information about the services offered, write or call the STAC in your state [see above].

NASA INVENTIONS AVAILABLE FOR LICENSING

Over 3,500 NASA inventions are available for licensing in the United States—both exclusive and nonexclusive.

Nonexclusive licenses

for commercial use of NASA inventions are encouraged to promote competition and to achieve the widest use of inventions. They must be used by a negotiated target date.

Exclusive licenses

may be granted to encourage early commercial development of NASA inventions, especially when considerable private investment is required. These are generally for 5 to 10 years and usually require royalties based on sales or use.

Additional licenses available

include those of NASA-owned foreign patents. In addition to inventions described in NASA Tech Briefs, "NASA Patent Ab-

stract Bibliography" (SP-7039), containing abstracts of all NASA inventions, can be purchased from National Technical Information Service (NTIS), Springfield, VA 22161. The Patent Abstract Bibliography (PAB) is updated semiannually. Call NTIS at (703) 487-4630.

Patent licenses for Tech Briefs

are frequently available. Many of the inventions reported in NASA Tech Briefs are patented or are under consideration for a patent at the time they are published. The current patent status is described at the end of the article; otherwise, there is no statement about patents. If you want to know more about the patent program or are in-

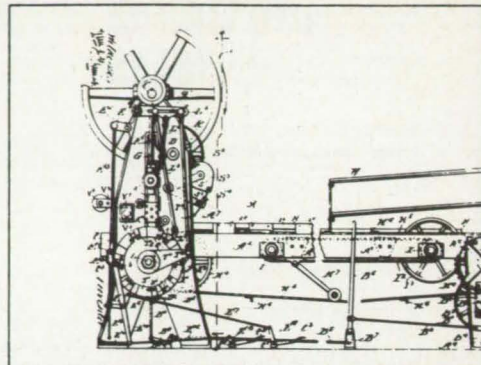

terested in licensing a particular invention, contact the Patent Counsel at the NASA Field Center that sponsored the research [see page 21]. Be sure to refer to the NASA reference number at the end of the Tech Brief.

INDUSTRIAL APPLICATIONS CENTERS

Computerized access to over 100 million documents worldwide

Computerized information retrieval

from one of the world's largest banks of technical data is available from NASA's network of Industrial Applications Centers (IAC's). The IAC's give you access to 2 million technical reports in the NASA data base and to more than 50 times that many reports and articles found in nearly 250 other computerized data bases.

The major sources include:

- NASA Aerospace Data Base
- DOE Energy Data Base
- NASA Tech Briefs
- Engineering Index
- National Technical Information Service (NTIS)
- Chemical Abstracts
- Computer Data Base

- INSPEC
 - Patents
 - Engineering Conferences
 - Computer Programs (COSMIC)
- and many other specialized files on food technology, textile technology, metallurgy, medicine, business, economics, social sciences, electronics, physical science, surface coatings and oceanography.

The IAC services

range from tailored literature searches through expert technical experience. • *Retrospective Searches:* Published or unpublished literature is screened and documents are identified according to your interest profile. IAC engineers tailor results to your specific needs and furnish abstracts considered the most pertinent.

Complete reports are available upon request.

- *Current-Awareness Searches:* IAC engineers will help design a program to suit your needs. You will receive selected weekly, monthly, or quarterly abstracts on new developments in your area of interest.
- *Technical Assistance:* IAC engineers will help you evaluate the results of your literature searches. They can help find answers to your technical problems and put you in touch with scientists and engineers at appropriate NASA Field Centers.

Prospective clients can obtain more information about these services by contacting the nearest IAC [see page 21]. User fees are charged for IAC information services.

APPLICATION TEAMS

Technology-matching and problem-solving assistance to public sector organizations

Application engineering projects

are conducted by NASA to help solve public-sector problems in such areas as safety, health, transportation, and environmental protection. Some application teams specialize in biomedical disciplines;

others, in engineering and scientific problems. Staffed by professionals from various disciplines, these teams work with other Federal agencies and health organizations to identify critical problems amenable to solution by the application of existing

NASA technology.

Public-sector organization

representatives can learn more about application teams by contacting a nearby NASA Field Center Technology Utilization Office [see page 21].

TECHNOLOGY UTILIZATION OFFICE, NASA SCIENTIFIC & TECHNICAL INFORMATION FACILITY

Centralized technical office to provide service to the U.S. professional community and general public

Missing a copy of NASA Tech Briefs?

Not received Technical Support Package requested? Want to check on Tech Briefs status? Have urgent request for subscription address change? Wish to receive other

Tech Brief in area of interest? Simply confused as to whom to contact within the NASA Technology Utilization Network? Have general or specific question about the Technology Utilization Program, its

services and documents?

We are here to help you. Write or call. We have the right answer, the correct document, or the proper referral [see page 21].



Buck never had it so good.

Motorola reliable power converters. Customized for spacecraft.

Motorola's technologically advanced power converters are customized for each spacecraft. Supported by special test equipment and software, these fully-redundant, radiation-hardened, EMP/EMI protected power converters provide

the reliability, efficiency, regulation, isolation and packaging needed for near and deep space missions. It's easy to have it much better than Buck. Call 602/897-4621 or write Box 2606, Scottsdale, AZ 85252.



MOTOROLA INC.

Government Electronics Group

Circle Reader Action No. 375



THE ONLY ALL-AMERICAN IN THE FIELD. THORNEL[®] CARBON FIBERS.

If your field is aerospace design and you're looking for carbon fiber products that are made in the U.S.A., there's only one way to fly.

Union Carbide's THORNEL pitch and PAN based carbon fibers. And THORNEL Advanced Composite Systems high modulus preregs.

Union Carbide offers carbon fibers and preregs that are made solely from domestically produced materials and manufactured here in the States. In fact, we have two fully integrated plants in Greenville, South Carolina.

Our THORNEL carbon fibers and preregs provide you with a consistently high quality product. Backed by unmatched on-the-spot technical support, continuing R&D and a resins technology background unequaled in the industry.

You'll appreciate the light

weight and superior stiffness, as well as the high thermal conductivity, dimensional stability and rapid vibration damping ability of our THORNEL pitch fibers.

For consistent properties in strength critical applications you'll want to look into Union Carbide THORNEL PAN fibers.

There's no reason to be up in the air about any of our THORNEL products. For more information contact your local Specialty Polymers and Composites Sales Representative or write to Union Carbide, 39 Old Ridgebury Road, Dept. M-1553, Danbury, CT 06817.

We'll show you how to get your designs off to a flying start without leaving home.

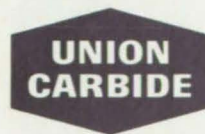

Specialty Polymers and Composites

New Product Ideas



New Product Ideas are just a few of the many innovations described in this issue of *NASA Tech Briefs* and having promising commercial applications. Each is discussed further on the referenced page in the appropriate section in this issue. If you are interested in developing a product from these or other NASA innovations, you can receive further technical information by requesting the TSP referenced at the end of the full-length article or by writing to the NASA Scientific and Technical Information Facility, Technology Utilization Office, P.O. Box 8757, BWI Airport, MD 21240 (see page 21). NASA's patent-licensing program to encourage commercial development is described on page 22.

Holder for Tinning Microcircuit Leads

A heat-sinking tool holds microcircuits for lead tinning while protecting the circuits from heat of the tinning solder. The tool includes two open-box-shaped holders that grip the microcircuit. The leads to be tinned protrude from the gap between the holders. The holders are on the ends of a pair of tweezers that are squeezed open to grasp the microcircuit. As the finger tension is released, the holders close firmly around the microcircuit. The leads are then fluxed and dipped into the solder.

(See page 136.)

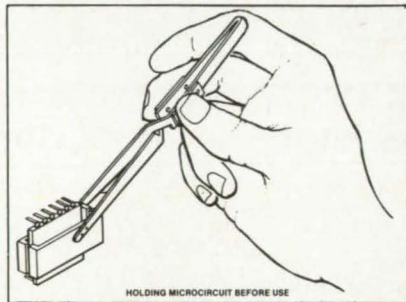

Emergency Brake for Tracked Vehicles

An emergency caliper braking system automatically stops a vehicle running on a track whenever the vehicle is in danger of traveling beyond the required stopping point. If the vehicle is about to travel past this point, a bar on the underside of the vehicle dislodges a slippery polytetrafluoroethylene-coated spacer block from between the brake pads mounted on the track rails (see figure). The brake pads, continuously energized by spring or air pressure, grip the bar, decelerating the vehicle. The operation of the brake triggers a pressure-activated switch on the air-pressure supply or a limit switch on the brake pads, or both, which sends a signal to shut off the vehicle power. The system may be useful on elevators and amusement rides and in mines and heavy industries.

(See page 118.)

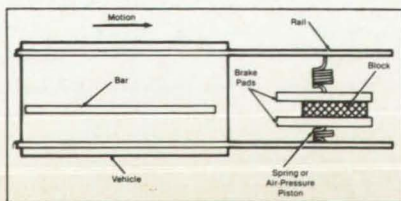

Easily Accessible Camera Mount

A modified mount significantly reduces the time required to install high-speed instrumentation movie cameras in explosionproof housings. In the previous mount, the positioning of the mounting screw at the rear left little room between the camera and the housing for the installer's fingers to tighten the screw to secure the camera. Consequently, the tightening was often inadequate, in which case the camera would come loose from vibrations and produce blurred images. With the modified mount, the screw is on the side, readily reachable through the side door of the housing. A right-angle drive mechanism containing two miter gears that turn a threaded shaft aligns the camera in the housing and secures it.

(See page 99.)

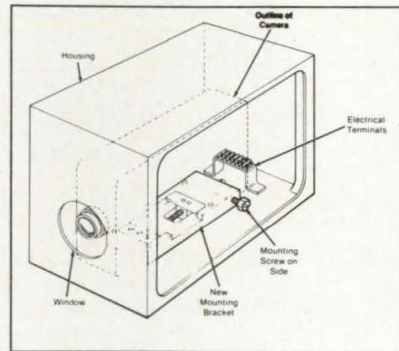

Ice Detector for Aircraft

A three-gauge device detects and measures the thickness of ice and water on aircraft skin. This information can serve as a warning to pilots to take appropriate measures for ice removal, either by heating the skin or by changing flight speed or elevation. One gauge of the ice detector determines just the presence of ice and water. Another gauge determines the electrical capacitance of such deposits, the capacitance being directly related to the thickness of the layer. The third gauge measures the temperature of the deposit to sense whether the skin is covered by ice or water.

(See page 100.)

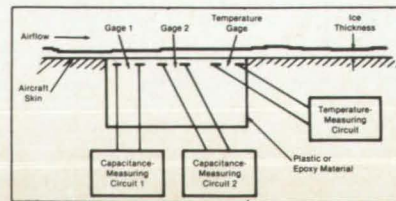

**Now it's a piece of cake
to do business with Kodak.**

The new Kodak Imaging Systems Center and Kodak's new Government Systems Division are now open for business. The sole purpose of both: to make it easier for the government to do business with Kodak. This new division of Kodak is all divisions of Kodak. We can help you with any Kodak product from a floppy disk to a mirror for a space telescope. With special emphasis on imaging systems for information management. All it takes is one call to (703) 558-8500.



Or one visit to
1300 N. 17th Street,
Arlington, VA 22209.

**Kodak's new
Government Systems
Division.**

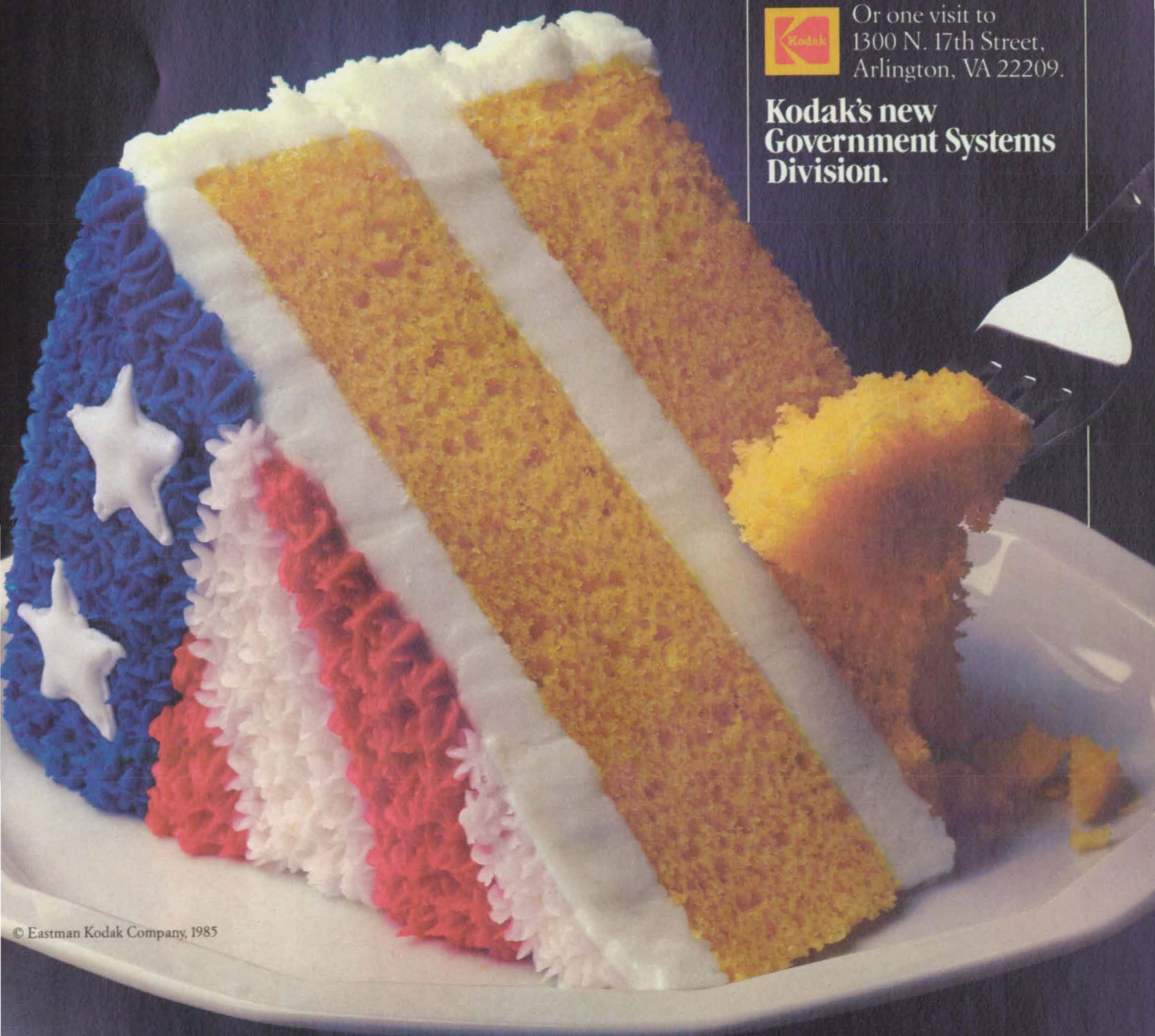

© Eastman Kodak Company, 1985

Circle Reader Action No. 339

Electromagnetic Hammer for Metalworking

An electromagnetic hammer that can generate momentary pressures up to 5×10^4 psi (3.4×10^8 N/m²) requires no dynamic material contact with the metal workpiece; consequently, it produces almost no change in the metal grain structure. The desired deformation of the metal workpiece results from the magnetic repulsion between surging electric currents in the work coil of the hammer and thereby induced eddy currents in the part of the workpiece facing the coil. The coil (see figure) is a spirally wound conductor of beryllium copper with polytetrafluoroethylene spacers between its turns, and the coil currents result from the rapid discharge (by a switching device) of an energy-storage capacitor charged to a predetermined value. The coil is mounted in a holder that allows the coil to be kicked back by the magnetic repulsive force and to be repositioned simply by being slid back toward the workpiece.

(See page 128.)

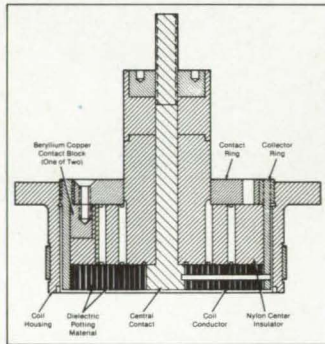

Internally Wrenching Nut

Parts in spaces inaccessible from sides by ordinary wrenches and in spaces too crowded to accommodate conventional nuts on projecting bolts can be tightened by a nut torqued by an allen wrench. The new nut should have many uses in assemblies where space is limited, especially in cars and aircraft. (See page 93.)

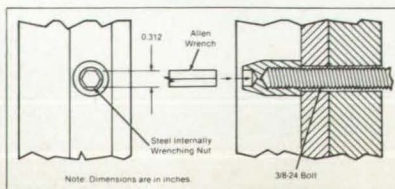

Transfer Mechanisms for Heavy Loads

Hydraulically-driven load-bearing mechanisms that produce small motions to emplace or remove heavy loads for transport may be useful in transferring large modular loads in railroads, agriculture, shipping, manufacturing, and garbage collection. The upper mechanism (see figure) in each two-mechanism set lifts the load and moves it horizontally. It supports loads of up to 39 klb (173 kN) and exerts a horizontal force of as much as 16 klb (71 kN) toward or away from the beam on which the mechanisms are held in position by shearpins through holes located at 10-cm intervals. The lower mechanism pushes or pulls horizontally but allows free vertical motion over a limited range. The ranges of the vertical and horizontal motions are sufficient to allow supports to be retrieved from under the heavy loads.

(See page 108.)

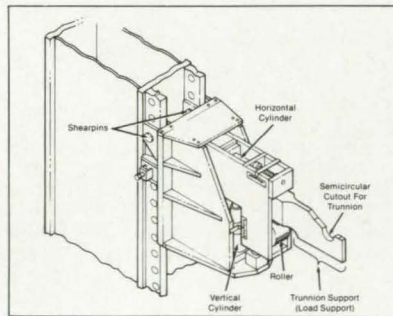

Rotating Drive for Electrical-Arc Machining

A rotating drive improves the shape of holes cut by an electrical arc. The holes are more nearly circular, the sides more nearly parallel to hole axes, in comparison to holes formed by ordinary electrical-arc machining. This drive simply rotates the electrode as an electrical drill, while the arc burns off the metal in the workpiece to form a hole. Alternatively, the electrode can be stationary and the workpiece rotating.

(See page 120.)

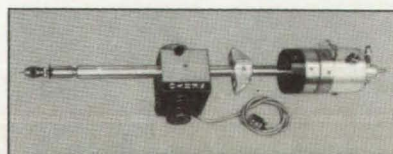

Portable Hydraulic Powerpack

A proposed rechargeable hydraulic powerpack would function as a lightweight, compact source of mechanical energy, that could power wheelchairs, drills, winches, and other equipment in areas that have no electricity, or replace electric and internal-combustion motors in explosive environments. Initiated by a small hammer, a chemical reaction occurring in a solid charge would produce hot gas at a safe rate. This gas would drive a turbine pump that pressurizes the hydraulic fluid in an accumulator; the pressurized fluid then could be used to do work on demand. Possible candidates for the solid charges are a combination of rubber and ammonium nitrate, and a mixture of sodium azide and copper oxide. (See page 115.)

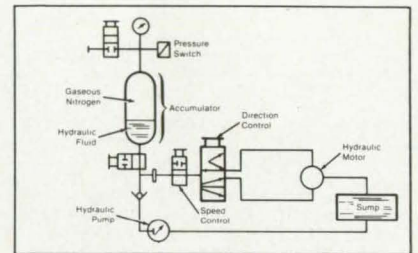

Flex Circuitry for Confined Spaces

Circuits preassembled on flexible wiring facilitates the installation of electronic equipment in confined spaces. The principal circuit elements — including mother boards, printed-circuit-board connectors, large bypass capacitors, and interface connectors are mounted on a flexible polyimide base containing nine layers of embedded copper-foil conductors. After the assembled flexible circuit has been visually inspected and tested for dielectric strength, insulation resistance, and continuity, all exposed connections are coated for electrical and mechanical protection. These flexible circuits eliminate the need for in-place hardwiring and allow smaller enclosures to be used.

(See page 52.)

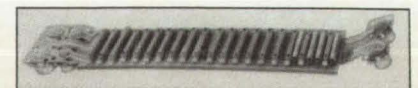

Precision Metal Products Engineered to Your Design Needs.

Designing the aircraft of tomorrow means solving complex systems requirements today. At Belfab we design and manufacture precision metal products that meet your requirements, while providing the durability and reliability features so critical to aircraft performance.

Capability. Since the dawn of

the space age Belfab products have been aboard our nation's most advanced commercial and military aircraft as well as the space shuttle, satellites

Mechanical Seal

and missiles. These products usually incorporate a bellows assembly, either edge welded or formed. Often, the bellows is only one of many components in the assembly and may serve any number of applications where there is a need for motion, flexibility, pressure sensing, fluid containment and zero leakage, while meeting limited space and weight restrictions.

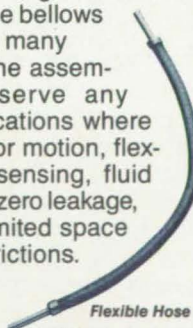

Flexible Hose

In addition, our capability to stamp, form, weld, machine, heat-treat, assemble and test, allows us to build your entire product in-house.



Flexible Coupling Fuel Drain Assembly

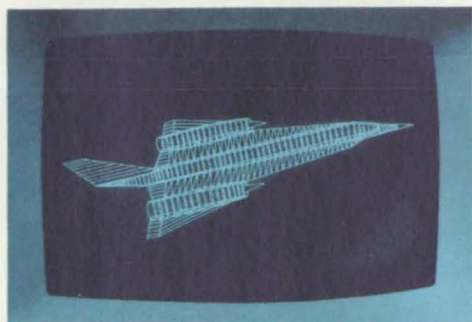

Durability.

Belfab products deliver benefits over and above a piece of hardware that simply meets your specifications. You receive a product engineered from the finest quality metals and alloys. A product that delivers long life while withstanding

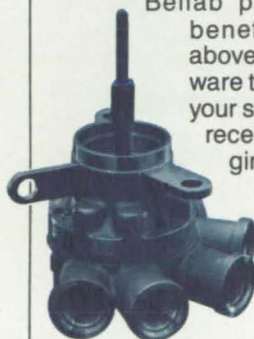

Valve

extreme temperatures, pressures, and highly corrosive media.

Reliability. Delivering precision performance under demanding conditions has been the trademark of Belfab products the past 30 years. Delivering free engineering support up front to help design a cost effective assembly has led customers to rely on our expertise to provide custom designs



Pressure Sensor/Actuator



Temperature Sensor/Actuator

that deliver top performance. And, delivering orders with a 90% on time record keeps our customers coming back time and again.

Free Application Analysis and Design.

Whether you are developing new aircraft or improving existing models, Belfab stands ready to help with precision metal products. To determine which product best suits your needs, our applications engineers will work with you at the outset of your project - at no charge or obligation - to analyze your performance requirements and to recommend solutions. To get started or to simply find out more about our capabilities, just call or write. We'll send you our free bellows design manual today . . . to help make it fly tomorrow.



Valve Stem Seal

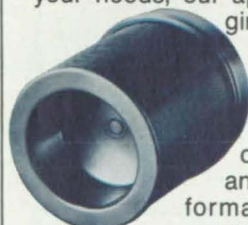

Volume Compensator



Thrust Control Bellows Assembly

East Coast: 305 Fentress Blvd. • P.O. Box 9370 • Daytona Beach, FL 32020

• Phone (904) 253-0628 • Telex 56-4355

West Coast: 9778 Katella Avenue • Suite 201 • Anaheim, CA 92804

• Phone (714) 530-1321 • Telex 18-3084

Circle Reader Action No. 301



Power
Technology
Inc.

LASER SIMULATOR (eye-safe)



CS100

These convenient, easy to use laser simulators are compact and self-contained. They provide a pulsed 1.06 micron infrared signal source simulating a YAG laser. Because of their portability, they are ideally suited to laboratory or field testing of laser rangefinders, and simulation of laser designators.

LASER DIODE PULSERS

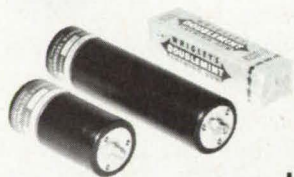

ILC

The ILC produces more average output power for driving laser diodes at 7 to 200ns pulse widths than avalanche or SCR pulsers. Models are available for pulse currents of 1 through 100A. Fast rise and fall times, with internal clock for pulse rates of 1 through 10,000 PPS.

LASER DIODE ARRAY PULSER



ILM

The ILM Series Laser Diode Pulser is designed to drive the ITT Ls 7711 or Laser Diode Labs LDT 350 Series Fiber Coupled laser arrays. An internal power supply allows operation from any available D.C. voltage between 10 and 28 volts.

POWER TECHNOLOGY, INC.

P.O. Box 9769

Little Rock, Arkansas 72219

Phone 501/568-1995

TWX 910/722-7313

Jig for Removing Rivets

A simple jig helps in drilling out rivets without damage to the surrounding material. The jig has a bushing with a base contoured to match a rivet head. The bushing is inserted into a hole in the jig handle and held in place by an adjacent screw that mates with a notch in the bushing. The operator places the bushing over the rivet with one hand and guides the drill through the bushing with the other. The bushing maintains the proper drilling direction along the rivet axis, preventing the incursion of the drill bit into the adjacent material. The rivet material that remains after drilling is scraped away.

(See page 113.)

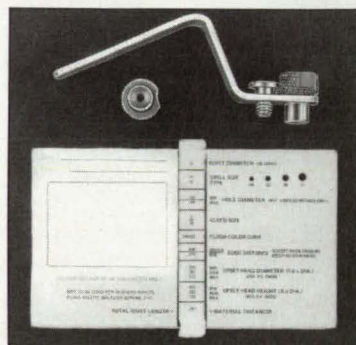

Colorless Polyimide Con- taining Phenoxy-Linked Diamines

Aromatic condensation polyimide films containing phenoxy-linked diamine monomers are essentially transparent in the visible spectral range and possess the toughness, flexibility, low density, thermal stability, radiation resistance, and mechanical strength of the commercial, bright yellow, aromatic polyimide film. These optically transparent/achromatic films should prove highly useful as film and coating materials for use on antennas, solar cells, thermal-control coatings, and other applications requiring high transparency with thermal stability. The production of these transparent polyimide films requires purification of both aromatic diamine and aromatic dianhydride monomers and the solvent used as a medium, and the introduction of phenoxy or thiophenyl "separator" groups and isomeric diamines into the polymer structure.

(See page 87.)

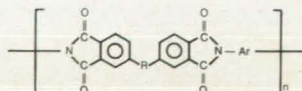

Microwave Sensor Measures Turbopump Speed

A microwave sensor measures rotational speed of a turbopump nonintrusively, even when the pumped fluid cavitates. In contrast, a magnetic or capacitive speed sensor protrudes into the flow near the rotating shaft, whereas nonintrusive optical speed sensors do not operate correctly during fluid cavitation. In the microwave speed sensor (see figure), a microwave signal from an antenna in the pump housing is reflected from a lobed, reflective encoder nut on the rotating shaft and returned, modulated by the reflections from the passing lobes, to the antenna. The returned signal is detected and low-pass filtered to extract the modulation. The modulation frequency is proportional to the rotational speed.

(See page 67.)

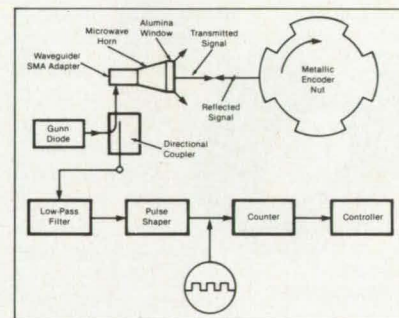

Pressure-Sensitive Resistor Material

A resistor in which resistivity decreases smoothly with increasing pressure is a promising candidate as a tactile sensor for robots and remote manipulators. The sensor consists of such particles of relatively low conductivity as antimony, silicon, magnetite, nodular graphite, or compound semiconductors embedded in rubber; e.g., room-temperature-vulcanizing silicone or castable urethane. The resistance of the sensor decreases by about 100 times as the pressure on it increases from 0 to 0.8 MN/m². For maximum resistance change, the embedded particles should be coarse, one-quarter to one-half the thickness of the sensor; uniform in size and shape; angular; hard; and resistant to wear. The rubber matrix should wet the surface of each particle as little as possible to prevent the resistivity from being too high and should have high tear resistance and low mechanical hysteresis.

(See page 86.)

NASA Tech Briefs, January/February 1986

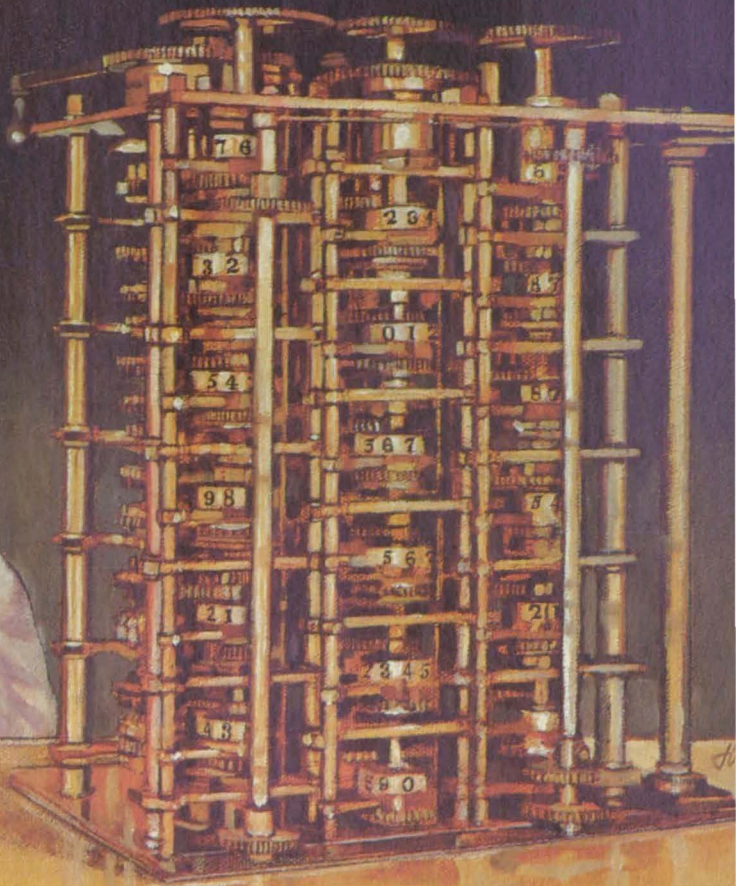

Sorry, Countess, this is one computer where you won't find VADS™!

Although the VERDIX Ada® Development System (VADS) won't be rehosted on Charles Babbage's Difference Engine, it is being hosted on and targeted for a variety of computer systems and embedded system architectures.

The Department of Defense (DoD) has now validated VADS for a growing number of computers and operating systems including the DEC/VAX™ series under UNIX™ 4.2 BSD and ULTRIX™, and for the Sun-2™ Workstation. Future product releases will include Host Development Systems for VAX/VMS™ and UNIX System V, and cross-targeted systems for 4 major architectures . . . Motorola 68000 and Intel "86" families, the National Semiconductor Series 32000®, and MIL-STD-1750A.

VADS is the fastest and friendliest Ada development

system available. It is specifically designed for large-scale Ada program development in a production environment.

VADS features a complete run-time system, plus an interactive, screen-oriented, fully symbolic debugger that lets you easily pinpoint errors. Unexcelled diagnostics and Ada library utilities quickly manage, manipulate and display program library information, dramatically shortening development times.

VADS from VERDIX. The finest, fastest and most cost-effective Ada Development System on the market today. The biggest breakthrough in programming since Ada herself.

For full information, call Curt Mason, Director of Sales, at (703) 378-2796.

VERDIX®

14130 Sullyfield Circle, Chantilly, VA 22021

Ada is a registered trademark of the U.S. Government, Ada Joint Program Office.
VAX, VMS and ULTRIX are trademarks of the Digital Equipment Corporation
UNIX is a trademark of Bell Laboratories
Sun-2 is a trademark of Sun Microsystems, Inc.
Series 32000 is a registered trademark of National Semiconductor Corporation
VERDIX and VADS are trademarks of Verdix Corporation

Circle Reader Action No. 398

Electronic Components & Circuits

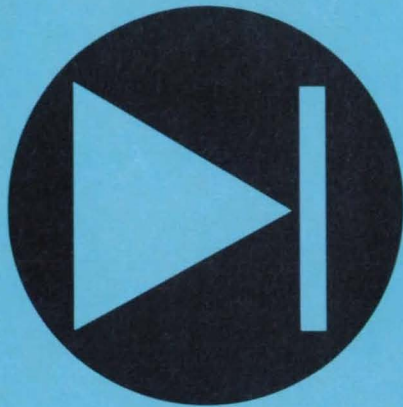

Hardware, Techniques, and Processes

- 32 Microstrip Antenna Generates Circularly Polarized Beam
- 34 Improved High/Low Junction Silicon Solar Cell
- 38 Increased Spectral Response for Charge-Coupled Devices
- 40 Submicron Silicon MOSFET
- 42 Buried-Dielectric-Microstrip Network
- 44 Brush-Type Connectors for Thermoelectric Elements
- 47 Phase-Locked Laser Array With Nonuniform Spacing
- 48 Ultrasonic Bonding to Metalized Plastic
- 48 Microwave Antenna With Reduced Noise Leakage
- 50 Pulsed-Corona Electrostatic Charger
- 51 Calculating Directivities of Planar-Array Antenna Feeds
- 52 Reliable One-Shot Separation of Connectors
- 52 Flex Circuitry for Confined Spaces
- 53 Improved Solar-Cell Tunnel Junction
- 54 Advanced IPV Nickel/Hydrogen Cell

Microstrip Antenna Generates Circularly Polarized Beam

Higher order modes are excited to produce conical radiation patterns.

NASA's Jet Propulsion Laboratory, Pasadena, California

A circular microstrip antenna excited with higher order transverse magnetic

(TM) modes can generate circularly polarized, conical radiation patterns. It has been

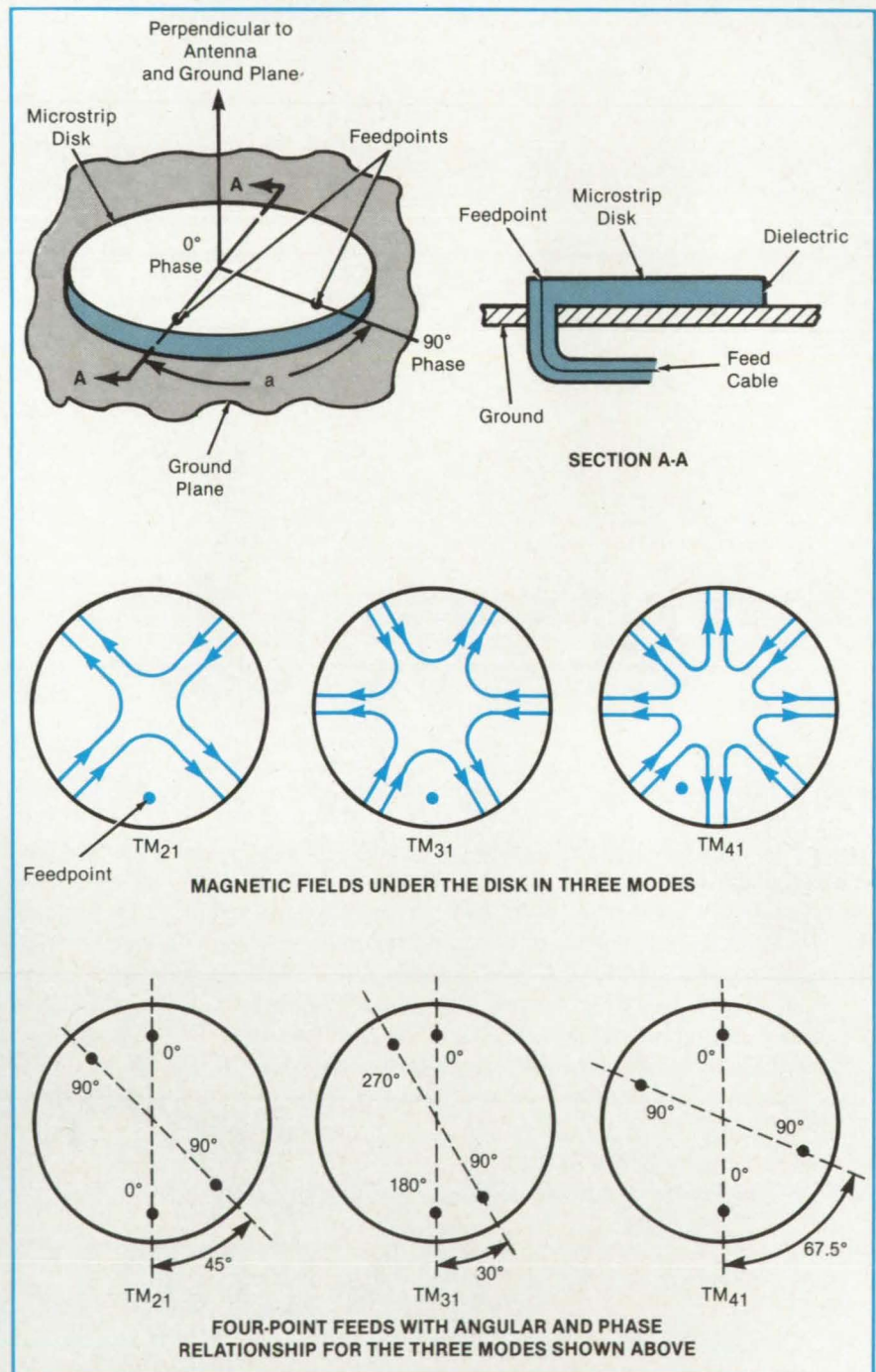

Figure 1. A **Microstrip Disk Antenna** is excited with two spatially and temporally orthogonal electromagnetic fields of a higher order $TM_{\phi r}$ mode (where ϕ and r represent the azimuthal and radial mode order, respectively). Shown here are examples of modes and the feeding arrangements needed to produce them.

When the challenge is handling propellants in space...



Fairchild Control Systems Company has the answers

Fairchild Control Systems Company has provided disconnects for every major space program requiring storable propellants, cryogenics, and gases. Our reliability and safety record is second to none.

If your system requires light weight, long life, low leakage, self-alignment, minimal pressure drop, manual or remote actuation, give the challenge to Fairchild Control Systems Company. We are the leader in fluid transfer technology . . . with more QD's in

space than all other competitors combined.

Fairchild's fluid transfer couplings used aboard:

- VOYAGER (Hypergolic)
- SATURN/APOLLO (Cryogenic)
- LUNAR MODULE (Oxygen and EGW)
- TITAN (Hypergolic)
- SPACE SHUTTLE (Hypergolic, Cryogenic, Pneumatic)
- SHUTTLE/CENTAUR (Cryogenic)

Fairchild Control Systems Company . . . meeting the aerospace challenges of today and tomorrow.



FAIRCHILD
CONTROL SYSTEMS COMPANY

Fairchild Control Systems Company
1800 Rosecrans Avenue
Manhattan Beach, California 90266
Tel.: (213) 643-9222
Telex: 910-325-6216

found both theoretically and experimentally that the peak direction of the radiation pattern can be varied within a wide angular range by a combination of mode selection and loading the substrate with materials of different dielectric constants.

To obtain circular polarization, one should use two feeds that differ in temporal phase by 90° . The feeds are located on the disk at the radius for best impedance matching. The angular spacing between the feed-points is chosen so that the two electromagnetic fields produced by the two feeds are perpendicular to each other both under and over the disk. An additional advantage of this angular spacing is that one feed-point lies in the null field region of the other feedpoint, with consequent minimization of undesired coupling between the feeds.

To preserve beam symmetry and minimize cross polarization, the user should suppress the unwanted modes. The two modes adjacent to the design resonant mode usually have the next highest amplitudes, but these modes are suppressed by placing two additional feeds diametrically across from the two original feeds. The required temporal phases of the four feeds are then $0^\circ, 90^\circ, 0^\circ,$ and 90° for the even modes and $0^\circ, 90^\circ, 180^\circ,$ and 270° for the odd modes. Several modes and four-point feeding arrangements are shown in Figure 1.

For a substrate of a given dielectric constant, an increase in the resonant-mode order causes an increase in the cone angle; that is, the radiation peaks along a cone that lies closer to the plane of the antenna. For a given mode, an increase in the dielectric constant also results in an increase of the cone angle. Figure 2 shows that several combinations of mode and dielectric constant can be selected to obtain peak-radiation (cone) angles ranging from 35° to 69° from the perpendicular to the antenna plane.

A phased array of circular microstrip antennas for directional scanning can be

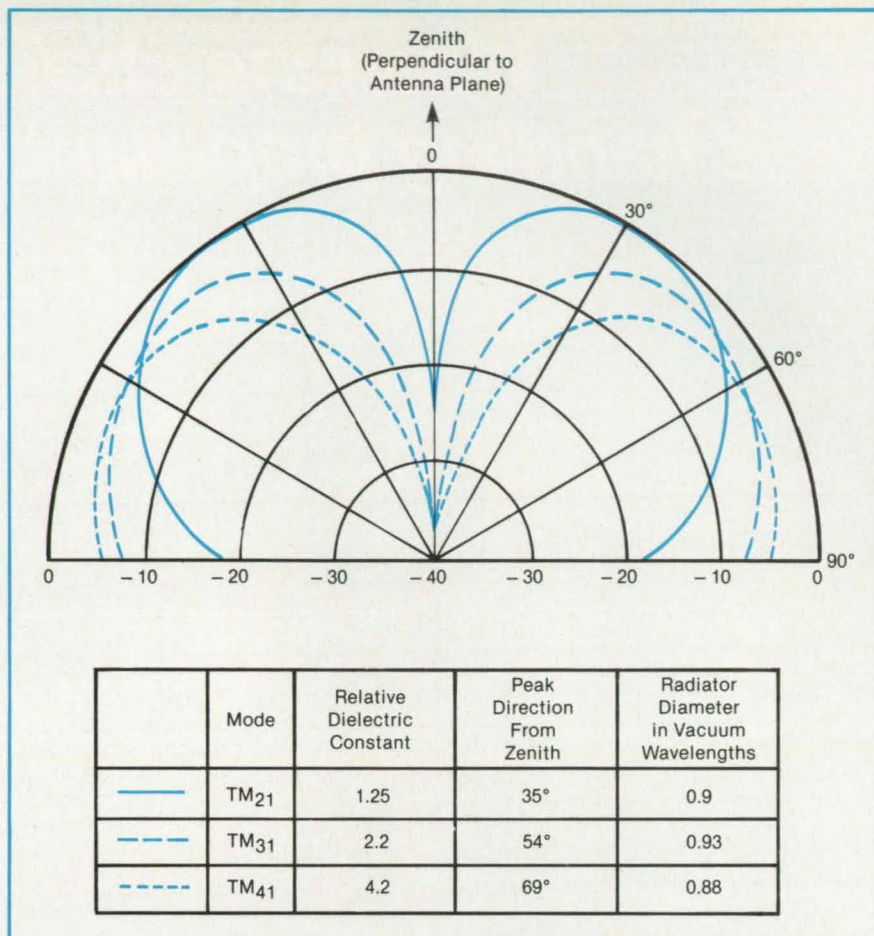

Figure 2. **Calculated Radiation Patterns** are plotted for three different combinations of modes and dielectric constants.

formed by placing such antennas side by side with a spacing of a half wavelength (in air, not in the dielectric). Because the resonant diameter of a disk for a higher order mode is usually larger than half an air wavelength, it is often impractical to form such an array. However, the resonant disk size is reduced by increasing the dielectric constant. In the TM₂₁ mode, for example, a disk with a substrate dielectric constant of 4.2 would have a half-wavelength resonant

diameter. A triangular lattice of antenna elements of this kind could be used for electronic scanning between about 10° and 70° above the horizon with little degradation in gain due to element pattern.

This work was done by John Huang of Caltech for NASA's Jet Propulsion Laboratory. For further information, Circle 19 on the TSP Request Card. NPO-16460

Improved High/Low Junction Silicon Solar Cell

The air-mass-zero open-circuit voltage is increased to 650 mV.

Lewis Research Center, Cleveland, Ohio

A method has been developed to raise the value of the open-circuit voltage in silicon solar cells by incorporating a high/low junction in the cell emitter.

The power-conversion efficiency of the low-resistivity silicon solar cell is considerably less than the maximum theoretical value mainly because the open-circuit volt-

age is smaller than simple p/n junction theory predicts. With this method, the air-mass-zero open-circuit voltage has been increased from the 600 mV level to approximately 650 mV.

The figure gives a cross-sectional schematic view of the proposed cell. Shown is the p-type substrate and the n-type emitter

comprising a low region and a high-electron-accumulation region. An oxide layer on the illuminated surface contains a high positive charge. Shallow n^+ contact diffusion regions underlie each of the one or more aluminum emitter contacts, and an ohmic contact underlies the p region.

A p/n junction exists between the emit-



WHY THERE'S NOTHING STOCK ABOUT OUR STOCK AND TRADE.

At Inland Motor we make very special motion control products—unique motors and controls for unique applications. As we've added these one-of-a-kind designs, our product base has evolved into an exceptional line of motion control products. "Standard" models...that deliver extraordinary solutions.

Specifically, at Inland Motor we offer products with a proven record of reliable, state-of-the-art performance in aerospace, robotics, defense, machine tool, process control and medical applications.

Our current product base includes the following:

FRAMELESS DIRECT-DRIVE DC MOTORS

These motors are especially well suited for applications where the aim is to maximize velocity and position accuracies. These near-infinite resolution motors are coupled precisely where the torque is required. (Direct drive means no gearing and no backlash.) Available in peak torques from 1 oz-in to 1,000,000 oz-in (5200 lb-ft).

FRAMELESS DC TACHOMETERS

Frameless DC tachometers are used where the requirement is quality angular velocity feedback. These devices are coupled directly where the velocity is to be measured. Available with ripple voltages down to 0.1% (average to peak), these tachometers will enhance the performance of your servo system.

BRUSHLESS DC MOTORS

These motors are especially well-suited to explosive, dry, liquid or low pressure environments, as well as ultra high speed or high power applications. Available in peak torques from 1 oz-in to 300,000 oz-in (1560 lb-ft).

LIMITED ANGLE MOTORS

Limited angle motors, which are also brushless, are suitable when torque is required over just a portion of a revolution, such as with scanners, throttle controls, and vibration test equipment. Available with excursion angles of up to $\pm 75^\circ$

If we don't already have the model you're looking for, we'll customize our motors to your exact requirements or design a new one—whether you need 10,000 or just 1. We can put them in a housing, and we can provide drive electronics.

If you'd like to know more about our stock and trade, or if you'd like help with a specific application, give us a call today at (703) 639-9045.

You can bet you won't get a stock answer.

Where imagination combines with technology.

INLAND MOTOR



KOLLMORGEN CORPORATION

SPECIALTY PRODUCTS GROUP

Radford, VA 24141 TWX 710-875-3740

Yesterday you had no choice...

350 MHz

SCOPES

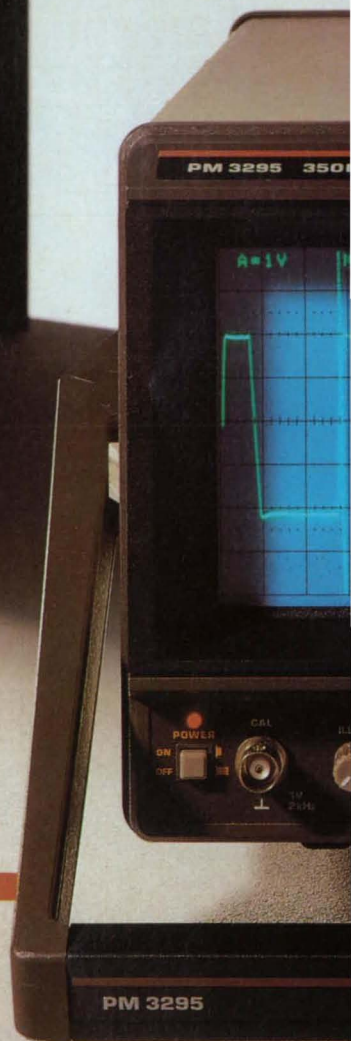

Philips' new 350 MHz generation

Now, the introduction of Philips' new 350 MHz generation means there's virtually no choice if you need today's most advanced technology in real-time high-frequency oscilloscopes.

These powerful instruments have a broad 350 MHz bandwidth and 1 ns rise-time, representing leading-edge technology in real-time oscilloscope design.

Writing speed is an ultra-fast 4 div/ns, ensuring secure capture and full waveform display of both single-shot and low-repetition signals.

Advanced user features

Numerous advanced user features provide the simplest possible operation. Like intelligent beam-finding, enabling multi-parameter auto-setting of amplitude, time

- 350 MHz bandwidth/1 ns rise time
- 4 Div/ns Writing speed (24 kV)
- Intelligent beam finding (AUTO SET)
- Manual/remote control
- LCD/LED status indication
- Cursors
- 1 mV - 5 V/Div vertical sensitivity
- 1 ns/Div sweep rate
- CRT read-outs
- Independent triggering
- Trigger input filters
- MIL specification



**Test &
Measurement**

...today you haven't got one either!

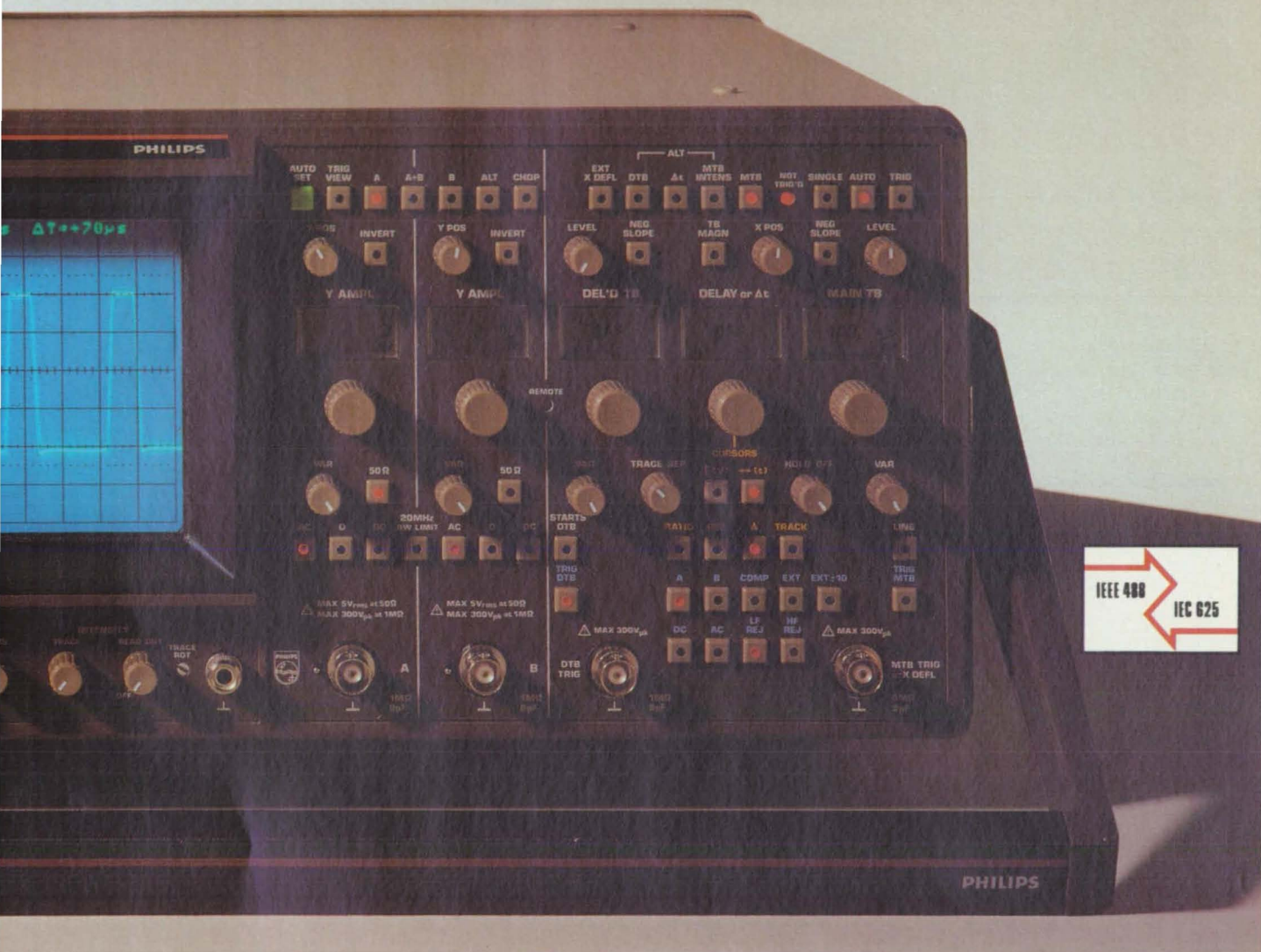

performance that gives you no choice.

base, trigger functions and screen display position.

Buffered switching ensures that read-outs and indicators always show current status. Voltage/time cursors simplify direct amplitude and time measurements. Full LED/LCD indications show status at a glance. And on-screen read-outs provide full operator guidance.

IEEE remote control option

Manual or remote control, via an IEEE remote control option, gives users the best of both worlds: flexible stand-alone operation, or programmable system-oriented applications.

Portable and rugged

Easy portability, built-in ruggedness and a comprehensive range of purpose-built acces-

sories are still more reasons why, after Philips' new VHF generation, you still have no choice in high-technology real-time scopes!

For full information about the new VHF generation from Philips, contact: In the USA call 800-631-7172 except Hawaii, Alaska and New Jersey. In New Jersey call collect (201) 529-3800, or write to: 85 McKee Drive, Mahwah, NJ 07430.

PHILIPS

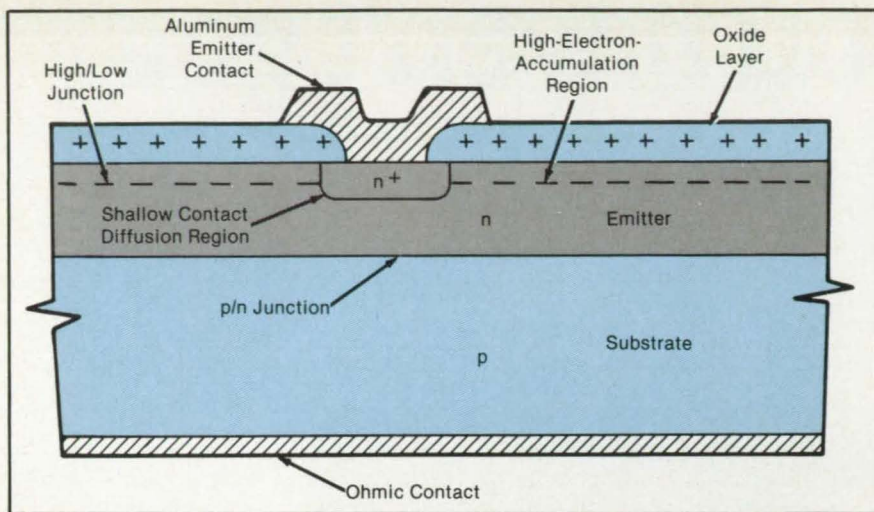

typically doped to about 10^{20} cm^{-3} . A heavily doped emitter region has the disadvantage that the dark emitter recombination is so large that it limits the maximum open-circuit voltage to about 600 mV. The high/low emitter suppresses the dark emitter recombination current, resulting in power-conversion efficiencies significantly higher than were previously achieved.

This work was done by Arnost Neugroschel, Shing-Chong Pao, Fred A. Lindholm, and Jerry G. Fossum of the University of Florida for **Lewis Research Center**. Further information may be found in "Emitter Current Suppression in a High-Low-Junction Emitter Solar Cell Using an Oxide-Charge-Induced Electron Accumulation Layer," A. Neugroschel, F. A. Lindholm, S. C. Pao, and J. G. Fossum, *Applied Physics Letters*, 33(2), 15 July 1978. Copies are available from the NASA Scientific & Technical Information Facility, P. O. Box 8757, Baltimore/Washington International Airport, MD 21240.

Inquiries concerning rights for the commercial use of this invention should be addressed to Patent Counsel, Lewis Research Center [see page 21]. Refer to LEW-13618.

ter region and the substrate. A high/low junction has been formed between the high-electron-accumulation region and the low emitter region. An aluminum metal contact is in ohmic contact with the emitter, and a shallow n^+ diffusion contact is made under this metalized portion of the top surface area. The aluminum emitter

contact covers no more than 5 to 10 percent of the surface area.

Provided in the proposed solar cell is a suppression of dark emitter current and an increase of short-circuit current. The emitter is less heavily doped — preferably in the $\sim 10^{18}$ to 10^{19} cm^{-3} range — compared to emitters of conventional cells, which are

Increased Spectral Response for Charge-Coupled Devices

Spectral response was determined from 1 to 11,000 Å.

NASA's Jet Propulsion Laboratory, Pasadena, California

Significant improvement in charge-coupled-device (CCD) spectral sensitivity was demonstrated over a remarkable range of 1 to 11,000 Å. The improvement in quantum efficiency, in conjunction with the CCD low-read-noise floor ($<4e^-$), opens up new scientific opportunities in the fields of biology, nuclear science, laboratory plasma diagnostics, and a host of other physical and astronomical applications in the UV, X-UV, and X-ray regimes. Figure 1 shows the best response that has been achieved to date, covering the soft X-ray to the near infrared.

The improvement in extending the spectral response of the CCD has come from proper preparation of the absorbing surface, in conjunction with charging the surface before use. Charging, which can be performed using ultraviolet flood, corona charging, or nitrogen monoxide gas, provides an ideal accumulation layer with the appropriate electric field to sweep minority carriers photogenerated at the back side into the front-side CCD depletion wells (see Figure 2).

This work was done by James R. Janesick and Tom Elliott of Caltech for

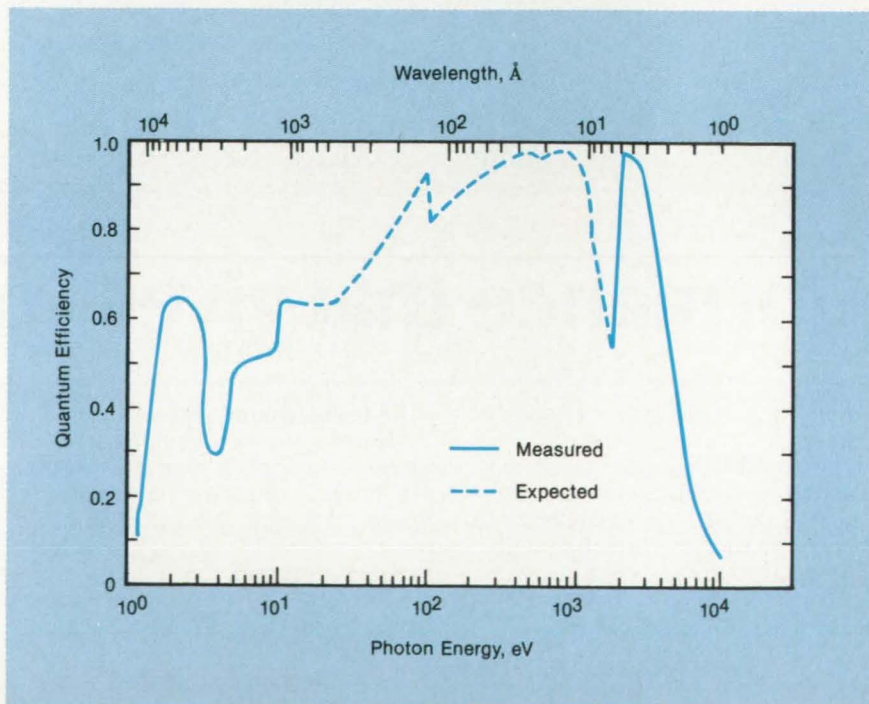

Figure 1. The Spectral Response of a CCD After UV Flooding indicates that the measured data correspond closely to theoretical performance, lending credence to the unmeasured portions of the curve.



IN A NUTSHELL, BOEING CAN HELP WITH MILITARY/AEROSPACE ELECTRONICS.

Last year alone, Boeing Electronics Company supplied over a quarter billion dollars worth of high quality electronics. We can handle the toughest electronics assignments in the industry.

For instance, we've produced some of the most sophisticated microcircuits available. Including thick-film hybrids and thin-film circuits.

We can provide everything from concept develop-

ment to packaging and design. And Boeing delivers what it promises — on time.

If you have a special requirement for micro-circuits, power supplies, ceramic circuit boards, controllers or avionics, give us a call.

Contact Boeing Electronics Company, P.O. Box 3707, M/S 9A-10, Seattle, WA 98124.

Or call (206) 575-5755.

Boeing Electronics Company
Reliability By Design

NASA's Jet Propulsion Laboratory. For further information, Circle 50 on the TSP Request Card.

Title to this invention has been waived, under the provisions of the National Aeronautics and Space Act [42 U.S.C. 2457(f)], to the California Institute of Technology. For further information regarding nonexclusive or exclusive licensing, contact Edward O. Ansell, Director of Patents and Licensing, 307 Keith Spalding Building, Pasadena, CA 91125. Refer to NPO-16150 and NPO-16290.



Figure 2. The **Potential Profile of a CCD** that has been thinned and UV-flooded produces a local field. This field directs the photo-generated charge toward the front-side potential well.

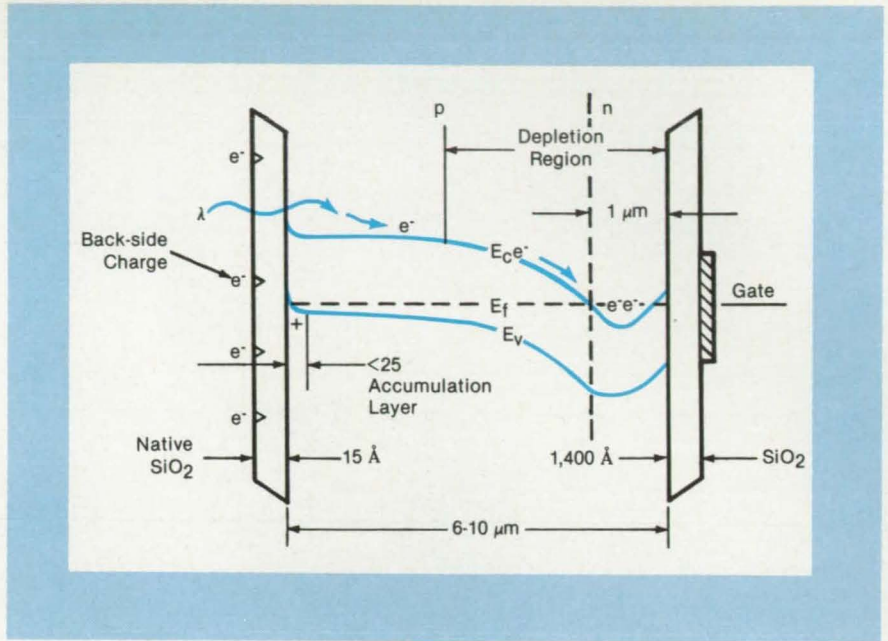

Submicron Silicon MOSFET

Gate length could be only a few hundred angstroms.

NASA's Jet Propulsion Laboratory, Pasadena, California

A suggested process for making metal-oxide/semiconductor field-effect transistors (MOSFET's) would result in gate-channel lengths of only a few hundred angstroms — about 100 times as small as those of state-of-the-art devices. Gates must be shortened to develop faster MOSFET's; the proposed fabrication process would be used to study the effects of size reduction in MOS devices and perhaps eventually to build practical three-dimensional structures.

The process requires a substrate of single-crystal [100] low-resistivity, n-type silicon. By molecular beam epitaxy or

another suitable technique, lightly-doped p-type silicon would be deposited on the substrate to a thickness of 200 to 500 Å. A 1-μm heavily-doped n-type layer would be deposited on the p-type layer.

A V-groove would be formed through the layers (see Figure 1) by anisotropic etching. An oxide layer would then be formed and metal deposited by conventional photolithography. No intricate submicron lithography is involved.

The proposed MOSFET structure may be deficient in two respects: First, the thin oxide may tend to break down in the source and drain regions at voltages high

enough to turn a device on. Second, the large source-to-gate and source-to-drain capacitances caused by the thinness of the oxide may limit device speed. A possible remedy (see Figure 2) may be to increase the oxide thickness in the source region so that the gate metal lies in proximity to the p-type gate material only.

This work was done by Taher Daud of Caltech for NASA's Jet Propulsion Laboratory. For further information, Circle 51 on the TSP Request Card. NPO-16601

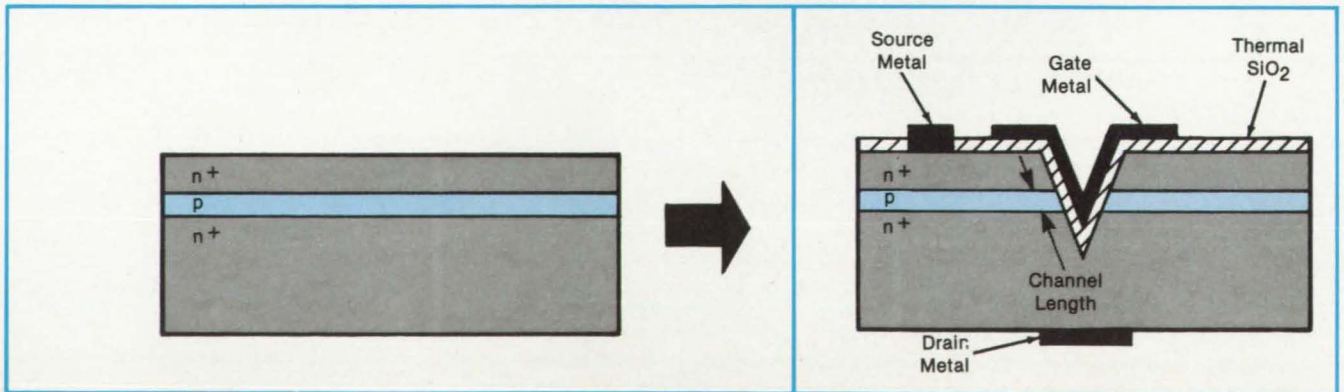
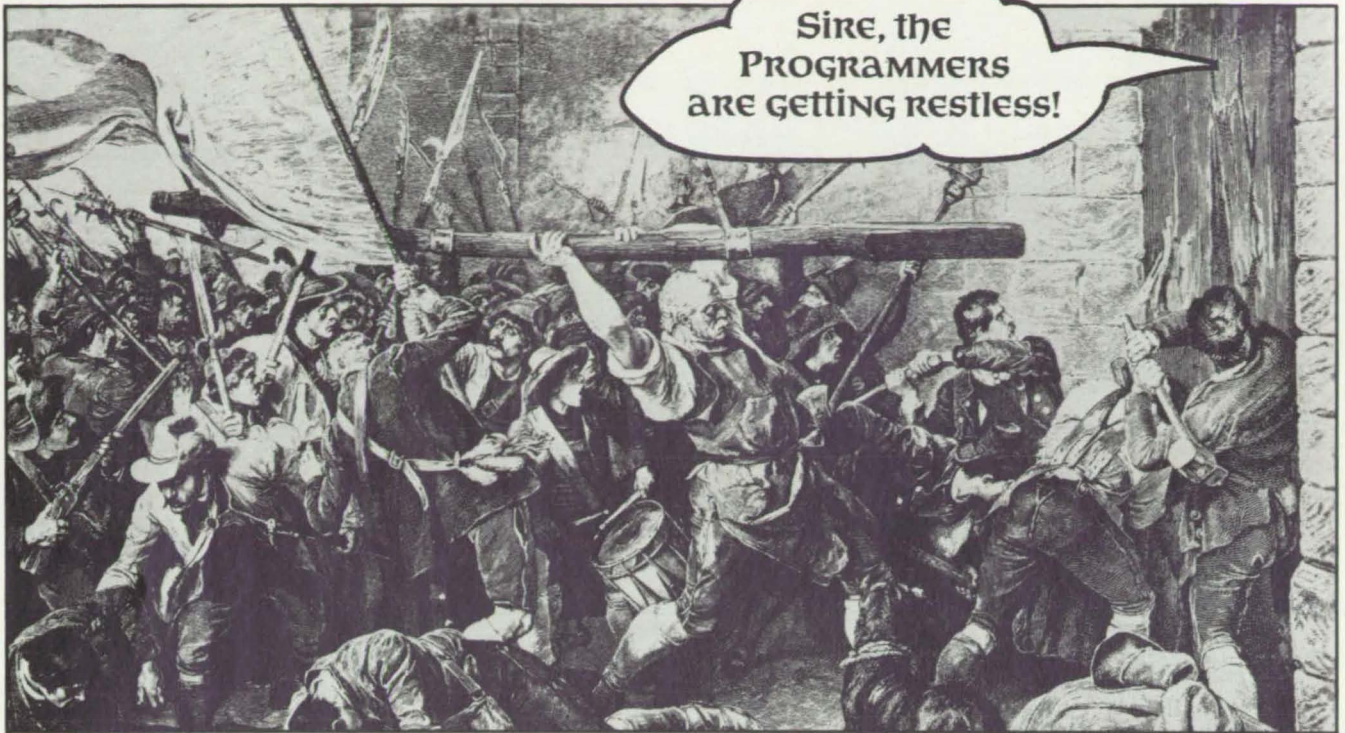

Figure 1. A MOSFET Would Be Formed by etching a V-shaped groove through semiconducting layers, then depositing an oxide insulating layer and metal contacts.



On November 18, 1985, at SIGAda in Boston, ALSYS opened the doors to Ada...

With Ada compilers for 15 computer models

Apollo Domain DN300, DN320, DN330, DN400,
DN460, DN550, DN600, DN660.
SUN Workstations 2/50, 2/100, 2/120, 2/160, 2/170.
Hewlett-Packard 9000, Series 200, 300.

With an Ada cross-compiler

DEC VAX 11/730, 11/750, 11/780, 11/785, and MicroVAX I
Cross-Compiler to Altos ACS 68000.

With Ada training products

You Know Fortran—Ada is Simple
(12 Lesson Computer-Aided Instruction for those
who know Fortran.)
Lessons on Ada
(2-Volume, 27 lesson CAI course running on IBM-
PC and VAX.)
Ichbiah, Barnes and Firth on Ada
(27 video tape overview of Ada by language
designers.)

With Ada programming tools

AdaQuery
(Complete, searchable on-line Ada Language Refer-
ence Manual.)
AdaViewer
(Unique viewing tool for Ada programmers.)

With more compilers in development

IBM-370 Compiler under development at Alsys Ltd., U.K.
Hewlett-Packard 1000 Series A900 Compiler under de-
velopment at Alsys Ltd., U.K.
IBM-PC/AT and IBM-PC/XT Compilers under develop-
ment at Alsys, Inc., U.S.

Alsys, Inc. • 1432 Main Street • Waltham, MA 02154 • U.S.A. • Phone: (617) 890-0030 • Telex: 948536
Alsys, S.A. • 29, Avenue de Versailles • 78170 La Celle St. Cloud • France • Phone: (3)918.12.44 • Telex: 697569
Alsys, Ltd. • Partridge Hse, Newton Road • Henley-on-Thames • Oxon RG9 1EN, England • Phone: (0491) 579090 • Telex: 846508

® Ada is a registered trademark of the U.S. Government (AJPO).

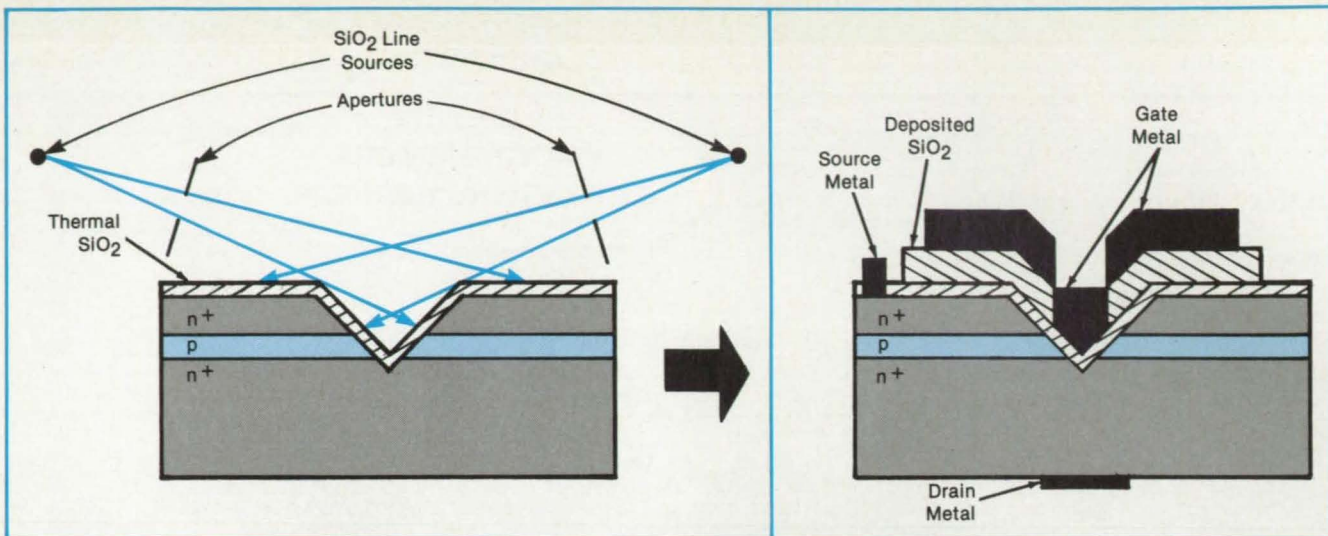

Figure 2. In an **Improved Version of the MOSFET**, two SiO₂ line sources would be used to form a thick oxide layer over the thermal oxide, which acts as a self-aligned mask. The gate metal would be deposited from a source aimed perpendicularly to the surface. Standard fabrication techniques would be used. High accuracy would be required only in controlling the oxide thickness.

Buried-Dielectric-Microstrip Network

A three-dimensional matching network is fabricated on a GaAs thin-film waveguide.

Langley Research Center, Hampton, Virginia

Continuous tuning of a CO₂ laser by phase modulation at microwave frequencies in GaAs thin-film waveguides has been reported previously. In optical waveguides, extremely-intense optical and microwave fields can be established, provided that special techniques are used to couple optical and microwaves efficiently into the device. If these two kinds of waves are properly synchronized with nearly-the-same phase velocity, very efficient and broadband modulation can be achieved. Phase modulation of CO₂ lasers at microwave frequencies generates both the upper and lower sideband frequencies, which can be well resolved from the laser carrier frequency. By varying the microwave frequency, one can tune the sideband power over a certain range. The tuning range depends critically on the modulator structure.

One of the problems in previous work has been in obtaining very-broadband and uniform frequency response. The problem was resolved with a buried-dielectric-microstrip matching network incorporated into an infrared-waveguide structure. This waveguide modulator structure represents the state-of-the-art of integrated optical devices: It has a three-dimensional shape to accommodate three quarter-wavelength-transformers for microwave impedance

matching at both the input and output terminals. The microwave network, along with a microstrip line designed with the aid of a computer, has been integrated with the optical waveguide and has been used to tune a line-selectable CO₂ laser that provides a total tuning range of 30 GHz in two sidebands.

To make a microwave tuned-

waveguide modulator, one must fabricate an appropriate electrode on a thin slab of GaAs with a metallic ground plane on the surface opposite that of the electrode. The electrode must be properly designed so that the guided infrared wave is synchronized with the traveling microwave to achieve high modulation efficiency. Another consideration in maximizing

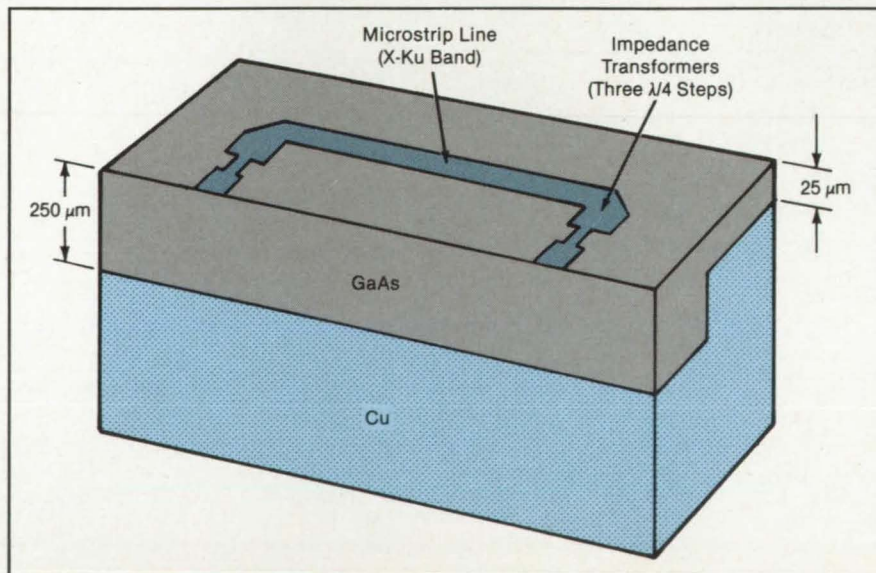

A Traveling-Wave, Infrared-Waveguide Modulator incorporates a buried-dielectric-microstrip matching network.

ASTRO-MED RE-INVENTS THE 8 CHANNEL OSCILLOGRAPH

NOW RECORD DC TO 500 HZ FULL SCALE... FLAT ON LOW COST THERMAL PAPER

Astro-Med MT-8500

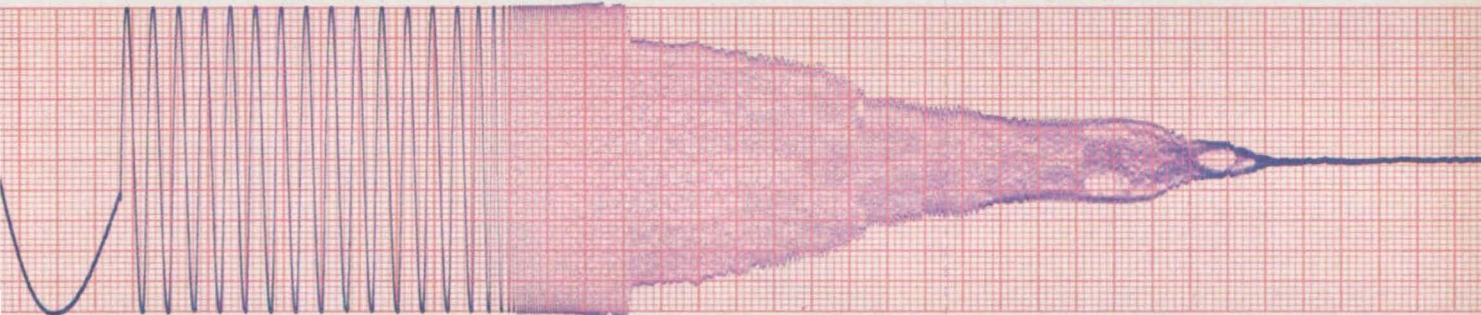
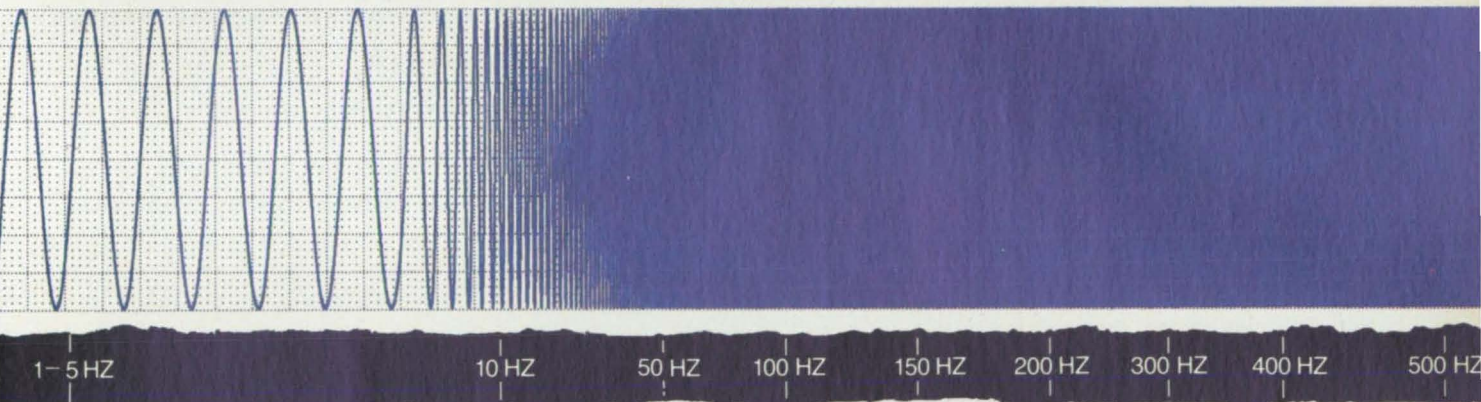

Conventional Stylus Recorder

Unretouched charts recorded at 25 mm per second

Stylus recorders with their moving mechanical components cannot maintain full scale amplitude above 75 Hz. The new 8 channel MT-8500 with no moving parts neatly solves the problem. It produces superb, permanent tracings to 500 Hz full scale, flat. And, since it prints its own chart on the fly, chart drift is a thing of the past.

Recording is thermal... no costly light sensitive papers. No messy inks or toners. The 8500 records 8 channels, introduces a unique new feature called "Wave Form Expansion", and records X-Y plots as well as X-T. Plus,

transient waveform capture to 5 KHz, and a full range of interchangeable plug-in signal conditioners.

The 8500 can be controlled locally or through the host computer, which we offer as an option: an IBM PC... with complete operations manual on a disk.

For complete details on the new 8 channel MT-8500, phone for a free brochure.
Toll Free 800-343-4039.



Astro-Med, Inc.

Astro-Med Industrial Park, West Warwick,
Rhode Island 02893 ☐ (401) 828-4000
Telex Number 710-382-6409

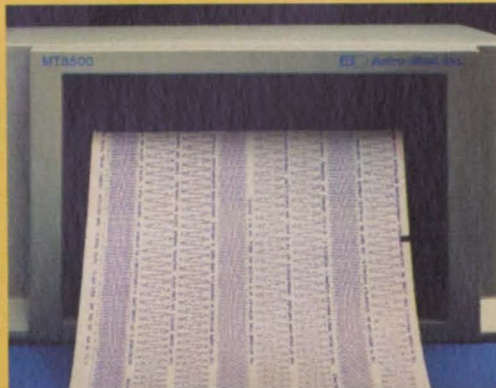

Circle Reader Action No. 424

sideband efficiency is to increase the microwave field in the waveguide by minimizing the microstrip width w and thickness t . The thickness of the microstrip has been reduced to $25\ \mu\text{m}$; however, optical-coupling considerations currently limit the reduction in microstrip width to $1\ \text{mm}$. The high aspect ratio ($w/t = 40$) of this microstrip yields a low impedance ($2.7\ \Omega$) that must be matched over a broad frequency band to a microwave source and termination.

Microwave energy can be coupled efficiently into a microstrip waveguide modulator provided that several quarter-wavelength-step impedance transformers (see illustration) are used to form a good match between the $50\text{-}\Omega$ input im-

pedance and the impedance of the modulator. The impedance of the transmission line can be adjusted by adjustment of the width of the microstrip electrode.

For a thin ($25\text{-}\mu\text{m}$) slab of GaAs, this approach can lead to a serious problem. To match the $50\text{-}\Omega$ impedance, one must reduce the electrode width to approximately $25\ \mu\text{m}$. At this width, the line is very fragile and not suitable for high-power operation. This problem is resolved with a thick ($250\text{-}\mu\text{m}$) GaAs slab integrated into the waveguide structure. With this thicker slab, a wider and more rugged electrode can be fabricated.

The modulator has been experimentally evaluated, and it provides very reliable and reproducible performance. It was de-

veloped primarily for remote sensing of the atmosphere, but it can also be used as a convenient and reliable analytical tool for very-high-resolution spectroscopic studies or for such other applications as isotope separation and frequency-multiplex communication. The buried-dielectric-microstrip network that enables the modulator to have state-of-the-art, 30-GHz sideband tunability, may also be used to match the impedances of other low-impedance microwave devices over a wide band.

This work was done by P. K. Cheo, R. A. Wagner, and M. Gilden of United Technologies Corp. for Langley Research Center. For further information, Circle 85 on the TSP Request Card. LAR-13285

Brush-Type Connectors for Thermoelectric Elements

Connectors ensure conduction of heat and electricity while accommodating thermal dimensional changes.

NASA's Jet Propulsion Laboratory, Pasadena, California

Wire brushes can be used to connect the positive and negative legs of semiconductor thermoelectric generators to power leads and to heat sources and sinks. The brushes are flexible thermal and electrical conductors that readily accommodate the expansion and contraction of the legs with changing temperature. Thus, direct conductive coupling between heat source and sink is allowed, in contrast to the older and less efficient method of having to couple radiatively to accommodate thermal expansion.

The electrical and thermal conductions of the brushes, at sufficiently-high wire-packing densities, can approach the magnitudes of solid metal contacts, with a compromise being made between flexibility and conduction properties. The brushes have the additional advantage of being more easily assembled to the legs in large arrays of p- and n-type elements (see figure).

Arrays of boron carbide p-type legs and lanthanum sulfide n-type legs would benefit particularly from the wire-brush connectors. These semiconductors expand with temperature at widely differing rates. Wire brushes of equal thickness could be used for both types of semiconductors and could accept the greatly different expansions of the two semiconductors without being stressed excessively.

This work was done by Charles Wood of Caltech for NASA's Jet Propulsion Laboratory. For further information, Circle 39 on the TSP Request Card. NPO-16545

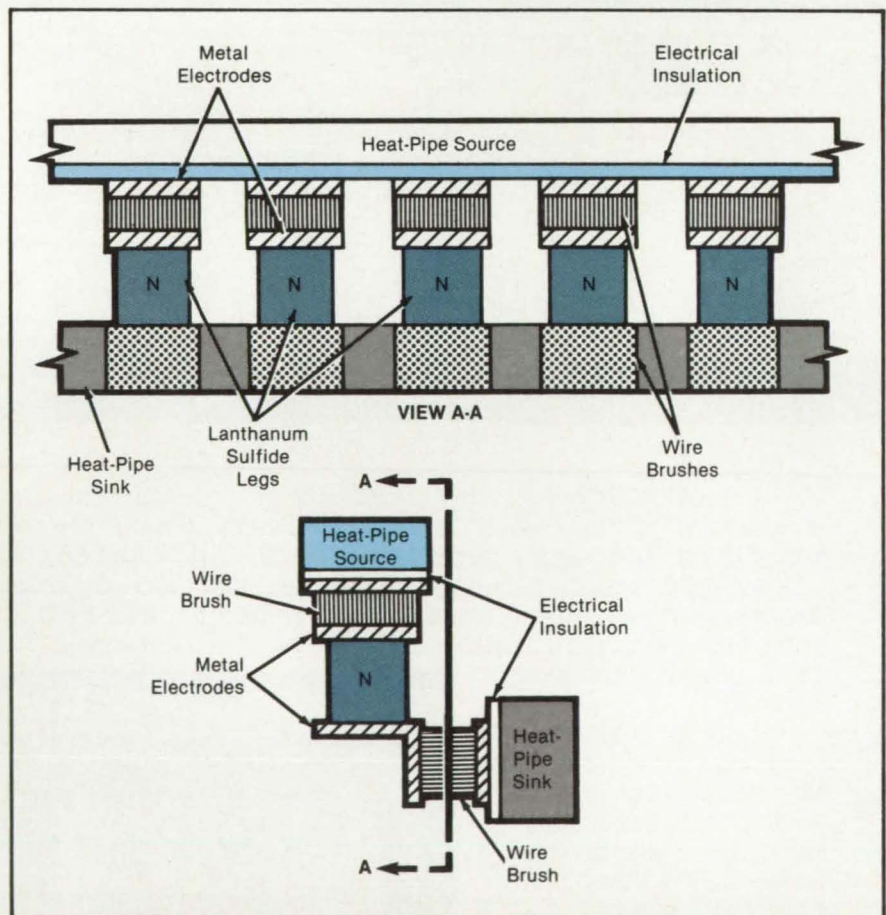

Wire Brushes join an array of similar-conductivity-type legs to the power bus and to the heat source and sink. An array of p-type legs would be positioned atop the heat-pipe source shown here in the same 90° configuration with a heat-pipe sink.

Digitization Enhances Oscilloscope Capabilities.

IWATSU'S NEW DS-6121

IWATSU is very proud to offer the best of both worlds, digital and analog. The DS-6121 is a 100 MHz equivalent time bandwidth oscilloscope, incorporating a 40 MS/s* sampling rate. It also functions as a 100 MHz analog oscilloscope with a 2 ns fastest sweep rate.

In addition, the DS-6121 can store 4 waveforms and a total of 6 front panel set-up conditions in nonvolatile memory. Voltage and time cursor measurements can be made

- 100 MHz analog/digital storage bandwidth
- 10 MHz single-shot digital bandwidth with interpolation
- Glitch capture available (Model DS-6121A)

in both analog and digital modes, enabling easier measurements of important parameters. The DS-6121 also packs powerful analytical capabilities, such as GO/NO GO judgement. This powerful feature allows it, without a controller, to compare an incoming waveform with a reference waveform and make a GO/NO GO decision. If an out-of-limit condition occurs, the DS-6121 will capture, save, and report it.

- 40 MS/s* sampling rate
- Fully-programmable interface
- 3-year warranty

*MS/s: Megasamples/second

Circle Reader Action No. 429



IWATSU INSTRUMENTS INC.

430 Commerce Boulevard, Carlstadt, NJ 07072 Phone: (201) 935-5220 TLX: 27109890255

In Mathematical and Statistical FORTRAN Programming **IMSL** Gets You to the Solution **Faster**

There is a faster way to get from problem to solution. A way to reduce development time, simplify maintenance, improve accuracy. A way to measurably increase productivity by selecting from hundreds of complete, fully tested mathematical and statistical FORTRAN subprograms:

IMSL subroutine libraries

Comprehensive, economical, and supported by the world's leading supplier of FORTRAN libraries for mathematics and statistics.

Calling a routine from an IMSL library is faster than writing it. It's a simple fact, but it can mean a big improvement in the productivity of both people and computers. It's why professional problem solvers in more than 60 countries have chosen IMSL libraries as their standard resource for FORTRAN programming. **IMSL libraries get you to the solution faster.**

Broad Scope.

IMSL libraries provide the most comprehensive selection of mathematical and statistical FORTRAN subprograms available. In almost any numerical programming application, IMSL libraries will meet your current *and* future needs with over 700 high-quality subprograms.

Standard User Interface.

Uniform calling conventions and documentation for all supported computer environments make IMSL libraries easy to learn and easy to use. Programs developed using IMSL libraries are much simpler to de-bug and maintain than programs containing undocumented, non-standard or unverified code.

Wide Compatibility.

IMSL libraries are affordably priced and compatible with most computing environments, from supercomputers to personal computers. Making IMSL libraries available on all of your computer systems can expand development flexibility and enhance application portability in your multiple-computer environment.

Comprehensive Support.

IMSL product support includes expert consultation, regular software enhancement, and maintenance. These services are performed entirely by IMSL personnel to ensure quality and consistency. IMSL's systematic, comprehensive support is the best way to protect the value of your software investment.

Accuracy and Reliability.

IMSL subroutines are designed, and exhaustively tested, for accuracy and reliability—and continually verified through thousands of hours of computation by customers around the world. Using IMSL libraries not only increases productivity, but can also enhance the accuracy and robustness of your programs and applications.

Return this coupon to:

IMSL Sales Division
2500 ParkWest Tower One
2500 CityWest Boulevard
Houston, Texas 77042-3020, USA.

Telephone: (713) 782-6060

Telex: 791923 IMSL INC HOU

**In the U.S. (outside Texas) call toll-free
1-800-222-IMSL.**

- The IMSL Library MATH/PC-LIBRARY
 SFUN/LIBRARY STAT/PC-LIBRARY

Name _____

Department _____

Title _____

Organization _____

Address _____

City _____

State _____

Postal Code _____

Area Code/Phone _____

Telex _____

Computer Type _____

NTB8601

IMSL

Problem-Solving Software Systems

The IMSL Library MATH/PC-LIBRARY

Over 500 mathematical and statistical subroutines
Subroutines for mathematical applications (for IBM personal computers)

STAT/PC-LIBRARY

Subroutines for statistical analysis (for IBM personal computers)

SFUN/LIBRARY

Subprograms for evaluating special functions

Phase-Locked Laser Array With Nonuniform Spacing

A single far-field lobe is obtained.

Langley Research Center, Hampton, Virginia

Multiple-stripe lasers that produce high continuous-wave output powers have been demonstrated. Generally these devices use optical coupling between the stripes to provide for phase-locked operation, which results in stable beam parameters. However, phase-locked injection-laser arrays with well-defined stripes on regular centers tend to configure the relative phase between stripes so that adjacent stripes are operating 180° out of phase. This leads to an undesirable lateral far-field distribution that consists of two lobes symmetrically located about the facet normal with an angular separation determined by the center-to-center separation of the stripes.

To obtain a phase-locked array that reliably produces a single far-field lobe, a proposed configuration includes lasing stripes that are not placed on regular centers but are located in a regular way with nonuniform centers (i.e., with the spacing determined by some function). Alternatively, the lasing stripes may be placed on a set of periodic arrays with different stripe-to-stripe centers that are interlaced onto a single chip or placed in a structure in which the stripe-to-stripe spacing is random or pseudorandom.

A monolithic, phase-locked, semiconductor-laser array having a variable spacing between the lasing regions has been fabricated (see figure). This

design produces an output laser beam comprising substantially a single lobe. The center-to-center spacings between the lasing regions are variable across the array in a lateral direction: They decrease with increasing distance from the centerline. The lasing regions are spaced an effective distance apart such that the laser oscillations in the different lasing regions are phase-locked to one another.

The variable spacing of lasing regions or nonuniform stripe spacing on multiple-stripe lasers will have two important effects. First, depending on the waveguide configuration used, the relative phases between stripes may be altered as the stripe separation changes, leading to modifications of the far-field distribution. Second, since the far-field distribution results from the Fourier transformation of the near-field distribution, the nonuniform spacing will result in a modified far-field pattern. By using these two effects, it should be possible to tailor the stripe separation to produce far fields that are well suited for particular applications.

This work was done by Donald E. Ackley of RCA Corp. for Langley Research Center. For further information, Circle 33 on the TSP Request Card.

Title to this invention has been waived under the provisions of the National Aeronautics and Space Act [42 U.S.C. 2457 (f)], to the RCA Corp., Princeton, NJ 08540. LAR-13281

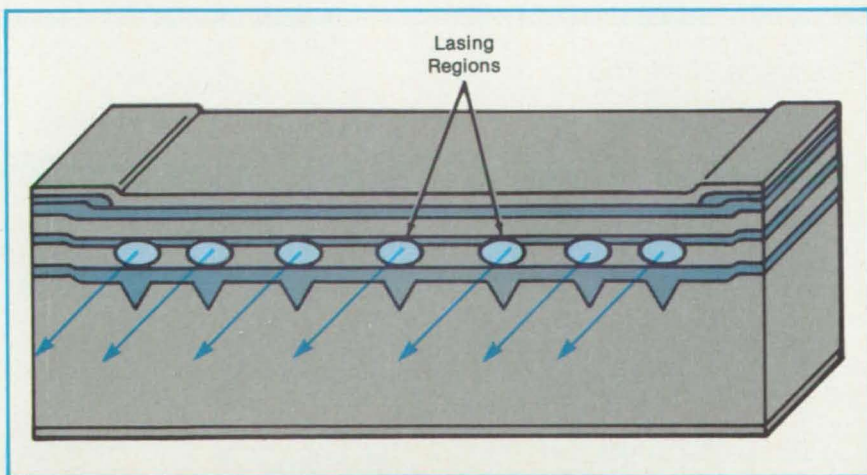

A Monolithic, Phase-Locked, Semiconductor-Laser Array has nonuniform spacings between lasing regions. The nonuniform spacing helps to suppress modes in which adjacent lasing regions operate 180° out of phase with each other.

NASA Tech Briefs, January/February 1986



GPIB

IEEE-488 Interfaces and Bus Extenders For:

IBM PC, PCjr & COMPATIBLES

DEC UNIBUS, Q-BUS & RAINBOW 100

MULTIBUS, VMEbus STD & S-100

Full IEEE-488 functionality, with the most comprehensive language and operating system coverage in the industry. It takes experience to make IEEE-488 systems work with nearly 4000 devices available from more than 500 different manufacturers, and experience is what enables National Instruments to take the GPIB to the second power and beyond.



Your personal guarantee of unsurpassed customer support and satisfaction. CALL 1-800-531-GPIB for instant access to 100+ man-years of GPIB experience.

NATIONAL INSTRUMENTS
12109 Technology Blvd.
Austin, TX 78727
1-800-531-5066 512/250-9119
Telex: 756737 NAT INST AUS

IBM and PCjr are trademarks of International Business Machines. MULTIBUS is a trademark of Intel. DEC, UNIBUS, Q-BUS, and Rainbow 100 are trademarks of Digital Equipment Corporation.

Circle Reader Action No. 348

47

Ultrasonic Bonding to Metalized Plastic

Unpackaged integrated-circuit chips can be attached to circuit boards.

NASA's Jet Propulsion Laboratory, Pasadena, California

A new technique makes it possible to bond wires ultrasonically to conductor patterns on such soft substrates as plain or ceramic-filled polytetrafluoroethylene. Previously, ultrasonic wire bonding could be used only with conductor patterns on such relatively hard substrates as sapphire, quartz, silica, or alumina.

Until now, ultrasonic wire bonding could not be done on soft substrates because these substrates have dissipated the bonding energy. In the new technique, a gold-plated copper disk is soldered to the circuit board at the point where the ultrasonic bond will be made. The disk concentrates ultrasonic energy at the bonding site so that strong and reliable wire bonds result (see figure).

With ultrasonic bonding, unpackaged chips can be attached to soft circuit boards. Previously, it was necessary to use packaged chips, which can be attached to such boards by solder or by conductive adhesive. The unpackaged chips are preferred because they require less substrate area and are better matched electrically to the circuit board at high frequencies.

This work was done by Bruce L. Conroy and Charles T. Cruzan of Caltech for

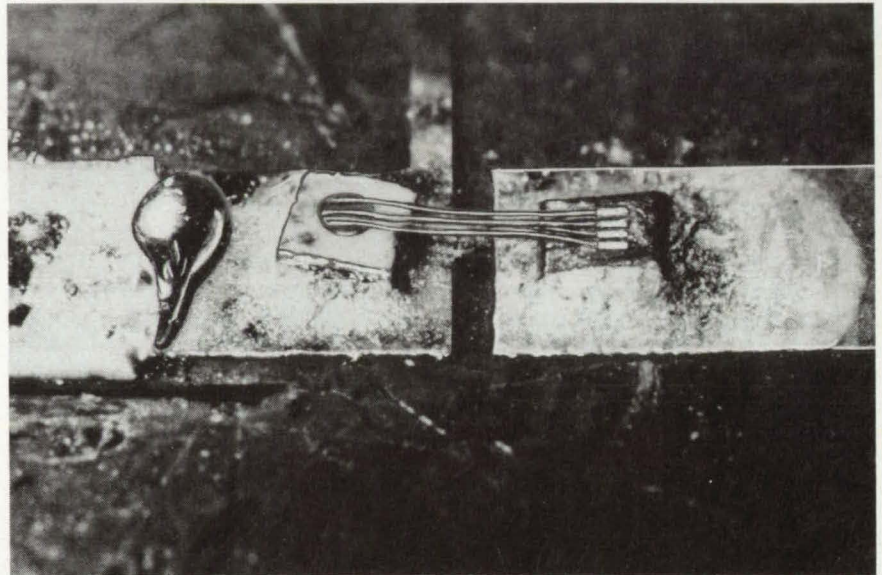

In a **Demonstration of Ultrasonic Bonding**, four fine wires were connected from a microwave component to a bonding disk on a metalized pad on a plastic substrate.

NASA's Jet Propulsion Laboratory. For further information, Circle 29 on the TSP Request Card.

Inquiries concerning rights for the commercial use of this invention should be ad-

ressed to the Patent Counsel, NASA Resident Office-JPL [see page 21]. Refer to NPO-16087.

Microwave Antenna With Reduced Noise Leakage

Feed-beam taper reduces rear spillover.

NASA's Jet Propulsion Laboratory, Pasadena, California

The gain or gain-to-temperature ratio of a dual-shaped subreflector receiving antenna is increased when the illumination is tapered near the aperture edge. The taper imposed in the antenna feed reduces spillover in the transmitting mode and reduces noise pickup in the receiving mode.

In a conventional dual-shaped subreflector antenna operating in the transmitting mode, the primary function of the subreflector is to direct more power toward the main-reflector aperture edge. This arrangement makes the illumination more uniform across the aperture, there-

TAPER EXPONENT, p	ILLUMINATION EFFICIENCY, η_I	REAR SPILLOVER EFFICIENCY, η_{RS}	$\eta_I \times \eta_{RS}$	ANTENNA ZENITH NOISE COMPONENT DUE TO REAR SPILLOVER, KELVINS
0 (Uniform Illumination)	0.996	0.943	0.939	14
0.25	0.994	0.976	0.970	5.8
0.50	0.973	0.990	0.958	2.3
0.75	0.943	0.996	0.939	1

Calculated Antenna-Performance Characteristics are shown for an antenna with a main-reflector diameter of 1,080 wavelengths and a subreflector diameter of 125 wavelengths, with four different feed-beam tapers.

SONY®

Component Products

- **Miniature CCD COLOR CAMERA, XC-117**
Picture Element 510(H) × 492(V)
- **CCD Black & White CAMERA, XC-37, XC-38, XC-39**
Picture Element 384(H) × 491(V)

**Let SONY's CCD CAMERA
FIT THE PICTURE!**



Measures in size: 1-11/16" × 1-1/8" × 2-7/8" (42.9mm × 28.6mm × 73.0mm)

Ideal for Diverse OEM Applications:

- *Robotics*
- *Process control*
- *Manufacturing automation*
- *Image processing*
- *Surveillance*

Other Complementary Products Available:

- Optical Lenses
- Flat Display Monitor
- Color Monitor

For Information Call:
CHORI AMERICA INC.
350 Fifth Ave., Suite 3323
New York, NY 10118
(212) 563-3264
Contact: Manabu Fukuda

or:
SONY® Industries
Electro Optics Division
15 Essex Road
Paramus, NJ 07652
(201) 368-5001

by contributing to the gain. The attempt to increase the gain is partly defeated, however, by the spillover, which is the loss of power beyond the edge of the main reflector due to diffraction by the subreflector.

When the antenna is used in the receiving mode, the inward flow of power over the spillover path results in the pick-up of undesired signals or thermal noise from the side or rear. For example, if the antenna is aimed toward the zenith, the inward spillover of thermal noise from the ground causes a temperature increase of about 2.4 K in the antenna for each percent of power lost in the transmitting mode.

To reduce the diffraction effect, the

aperture illumination pattern is synthesized so that the power density in the main aperture is proportional to

$$\left(1 - \frac{r^2}{R^2}\right)^p$$

where r is the radial distance from the aperture center, R is a length chosen to be somewhat greater than the radius of the aperture edge, and $0 \leq p \leq 1$. The choice of p determines the sharpness of the taper, with $p = 0$ representing conventional uniform aperture illumination. The synthesis of aperture illuminations with tapers like this is known from previous investigations.

A theoretical comparison was made among four tapers in a representative antenna design (see table). The numerical results show that as the taper exponent increases, the illumination efficiency decreases, but there is a compensating decrease in spillover resulting in an increase in spillover efficiency. If gain is the main criterion, then the design with $p = 0.25$ is the best of the four. When the spillover contribution to the antenna temperature is considered, then the design with $p = 0.75$ appears to offer the best performance.

This work was done by Alan G. Cha of Caltech for NASA's Jet Propulsion Laboratory. For further information, Circle 89 on the TSP Request Card. NPO-15785

Pulsed-Corona Electrostatic Charger

Small objects can be charged positively or negatively for electrostatic levitation.

NASA's Jet Propulsion Laboratory, Pasadena, California

An experimental charge-generating apparatus can supply nanocoulomb charges to small objects. The purpose of the experiments is to develop a contactless charger for solid or liquid spheroids in contactless (levitation) processing.

The circuit applies high-voltage radio-frequency (RF) pulses to either of two sets of electrodes (see Figure 1). These RF pulses generate a corona between the electrodes in each set, thereby generating ions. The RF pulses are superimposed on a 60-Hz high voltage applied across the space between the two electrode sets. This voltage accelerates the corona ions across the gap toward the opposite set of electrodes. An object placed in the gap intercepts some of the ions and becomes charged. Figure 1 shows a typical charging circuit and a charging head.

To charge the object with positive ions, the RF pulse is applied to a set of electrodes when that set is at or near the positive peak of the accelerating voltage. Alternatively, the set receiving the RF corona burst can be grounded and the burst applied when the other set is at the negative peak of the accelerating voltage. For the most effective positive charging, the accelerating-voltage transformer T_3 is center tapped to ground, and the RF burst is applied alternatively to each electrode set when it is near the positive peak of the accelerating voltage. Of course, the object can be negatively charged by applying the RF pulses at the negative peaks of the accelerating voltage.

Transformers T_1 and T_2 are identical fly-back transformers, each capable of a max-

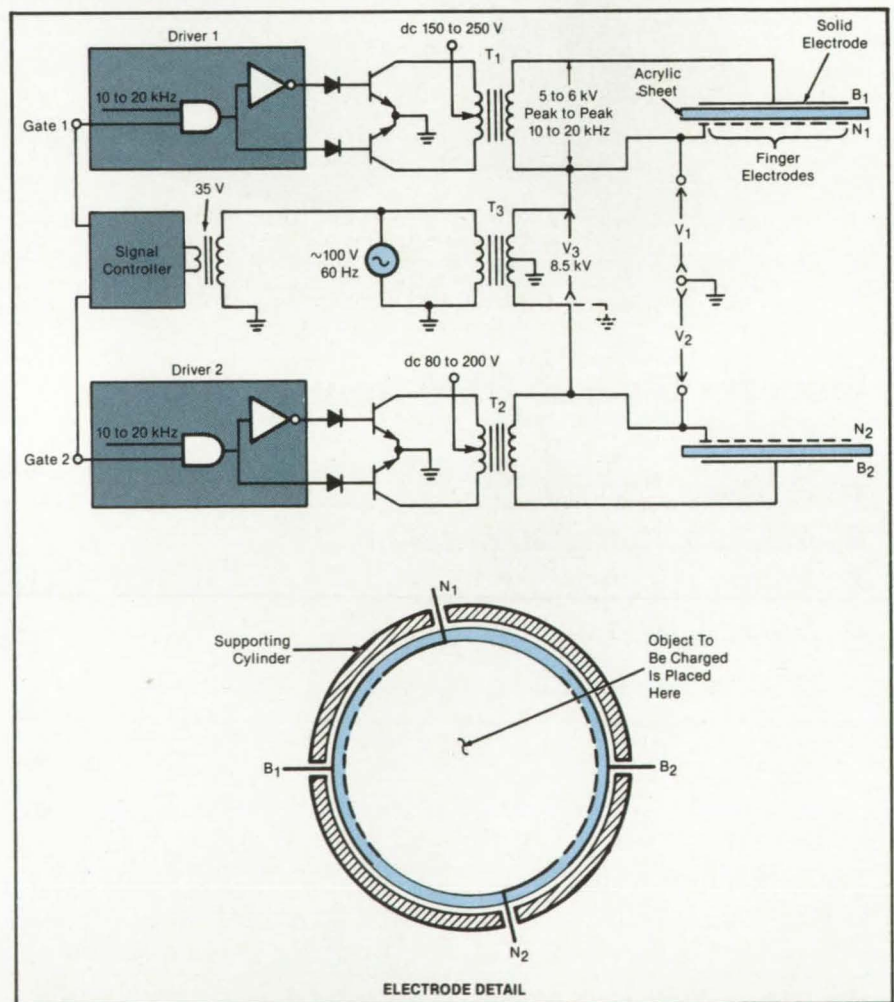

Figure 1. This Circuit Generates High-Voltage RF Pulses, which it applies between the two electrodes in each set. It also applies a 60 Hz high accelerating voltage between the two sets of electrodes. The two sets of electrodes are made of conductive paint on acrylic sheets, which are placed diametrically opposite each other in a supporting cylinder.

imum output of 8.5 kV at 1.5 mA. The RF signals are applied by the drivers, which are synchronized with the powerline voltage so that the RF pulses appear near the powerline peaks as shown in Figure 2. The starting time and duration of each RF pulse is determined by the parameters of multivibrators in the drivers.

The two electrode sets are made of conductive paint on acrylic sheets of 0.5 mm thickness. The solid electrode of each set is painted on one side of a sheet while the finger electrodes of each set are painted on the other side. The two sheets are bent to fit into a cylindrical holder of 81 mm inside diameter.

When the voltages are applied, there is a stable distribution of ac corona sites along the finger electrodes at a spacing of about 100 μm . To test the charger, a metal-

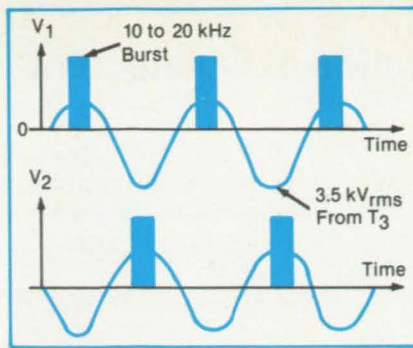

Figure 2. Voltages on the Finger Electrodes are shown here as a function of time for the circuit of Figure 1. With these polarities and timings, an object placed in the electrode cylinder would become positively charged.

ized glass sphere of 14.3 mm diameter was mounted on an insulating stalk at the center of the cylinder for about 5 s at a time. The sphere was then transferred to a faraday cup for the measurement of the charge.

The charge on the sphere was measured as a function of various combinations of RF and accelerating voltages and pulse timings. A maximum charge of 3.2 nC was observed with 5 ms RF bursts of 5.2 kV (peak to peak) positioned at 3.5 ms after the zero crossing of the accelerating voltage of 8.5 kV rms (center tapped).

This work was done by Won-Kyu Rhim, Daniel D. Elleman, Brian Makin, and William T. Simms of Caltech for NASA's Jet Propulsion Laboratory. For further information, Circle 3 on the TSP Request Card. NPO-16523

Calculating Directivities of Planar-Array Antenna Feeds

Radiation patterns are computed rapidly from expressions in closed form.

NASA's Jet Propulsion Laboratory, Pasadena, California

The design of planar-array antennas and antenna feeds is aided by a new approach to the calculation of array directivity. The technique takes into account polarizations, asymmetries in element patterns, nonuniform element spacings, and arbitrary excitations. It gives numerical results faster than previous integration methods, and the results agree with those obtained by the older methods.

The technique applies to a planar array of M identical radiating elements with identical polarization states at arbitrary locations and excited with feeds at arbitrary amplitudes and phases (see figure). The array is assumed to radiate only into the upper half space $z > 0$. The directivity D of the array in the direction θ, ϕ is defined by

$$D(\theta, \phi) = \frac{4\pi I(\theta, \phi)}{P}$$

where θ and ϕ represent the polar and azimuthal angles, P = the total radiated power, and $I(\theta, \phi)$ = the radiation intensity in that direction.

The calculation of P requires the integration of $I(\theta, \phi)$ over all solid angles. Until now, the practice has been to evaluate the integrals numerically. This is a tedious and time-consuming process. In the new approach, the process is speeded up by taking advantage of the fact that the integrals

are equivalent to closed-form expressions containing Bessel, gamma, and Lommel functions. These functions can be evaluated directly by table lookup or by series approximations.

The new technique was applied to some special cases including arrays with large spacings, elements with symmetric patterns, and linear arrays of isotropic elements. The technique was used to calculate the directivities of circularly polarized seven- and nine-element cluster feeds used in multiple-beam designs. It was also

applied to a 25-element array feed for a satellite antenna to produce a beam covering the eastern time zone of the United States. Comparisons were made with the results obtained from direct numerical integration and other, less general formulations. Excellent agreement was obtained in all cases.

This work was done by Yahya Rahmat-Samii and Shung-Wu Lee of Caltech for NASA's Jet Propulsion Laboratory. For further information, Circle 10 on the TSP Request Card. NPO-16505

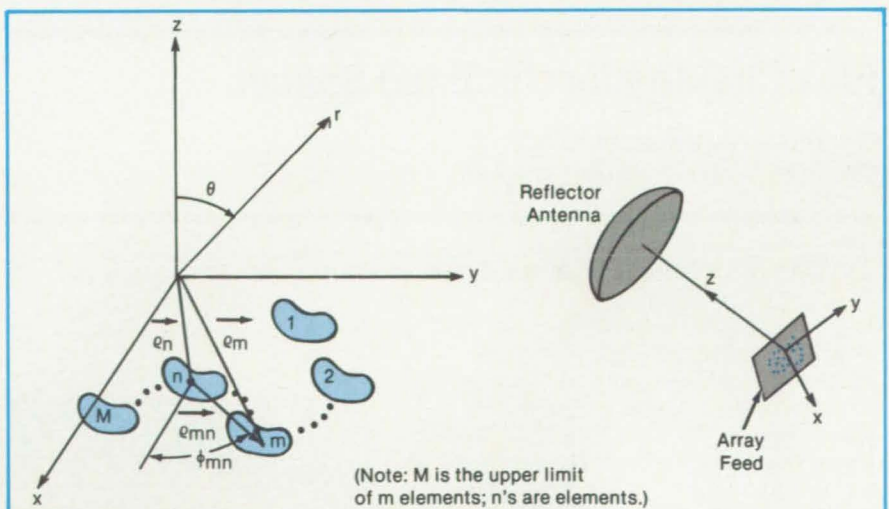

The Geometry of a Planar Array is shown with identical radiating elements, p, and polarization states located at arbitrary positions with arbitrary, complex excitation coefficients.

Reliable One-Shot Separation of Connectors

A mild explosion breaks the connection.

Lyndon B. Johnson Space Center, Houston, Texas

A concept for separating electrical connectors by remote control is simple and reliable. Suitable for one-time, irreversible separations, the method uses a weak explosion to destroy one member of the connector.

The connector consists of a threaded plug and socket (see figure) around which a tape of Superzip (or equivalent) explosive is wrapped. When the explosive is fired by an electrical signal, it fractures the socket case and releases its segmented connector elements, which are pushed upward and outward by a compressed and torqued spring. The plug is thereby freed. The concept is adaptable to fluid connections as well as to electrical ones.

This work was done by William R. Holmberg of McDonnell Douglas Corp. for Johnson Space Center. No further documentation is available. MSC-20839

A Connector Wrapped With Explosive opens upon detonation. The fractured socket elements may be tethered to prevent them from flying away and forming debris.

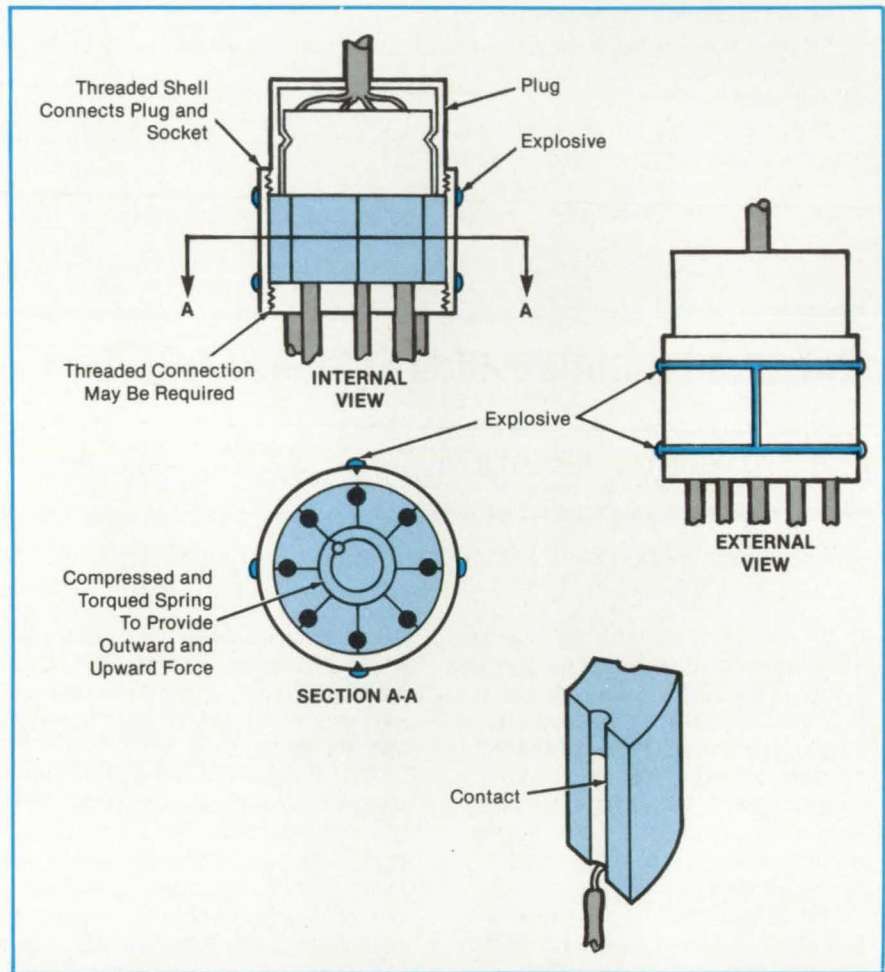

Flex Circuitry for Confined Spaces

Circuits are preassembled, then bent into confined spaces.

Lyndon B. Johnson Space Center, Houston, Texas

To facilitate the installation of electronic equipment in confined spaces, circuitry is preassembled on flexible wiring. Mother boards, large bypass capacitors, and interface connectors are mounted on the flexible wiring and tested before installation. Originally developed for use on the Space Shuttle, the flexible circuits eliminate the need for in-place hardwiring and allow smaller enclosures to be used.

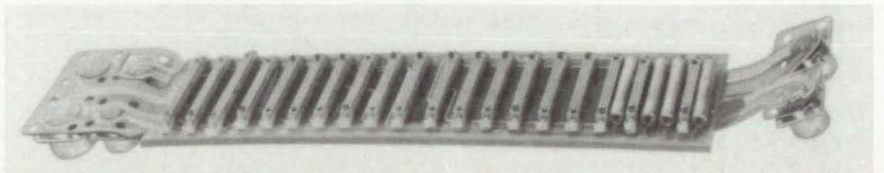

Flexible Wiring contains nine layers of copper conductors, on which are installed circuit-board connectors, cable connectors, and large capacitors. This type of wiring allows installation of complex circuitry in confined spaces.

The base for the flexible wiring is a polyimide, in which copper-foil conductors are embedded in nine layers. Once assembled (see figure), the flexible circuit is visually inspected and tested for dielectric strength,

insulation resistance, and continuity. When testing is completed, all exposed connections are coated for electrical and mechanical protection.

This work was done by Joel B.

FitzPatrick and Larry C. Maier of Simmonds Precision for Johnson Space Center. For further information, Circle 23 on the TSP Request Card. MSC-20773

Improved Solar-Cell Tunnel Junction

Cell efficiency would be increased.

NASA's Jet Propulsion Laboratory, Pasadena, California

The efficiency of multiple-junction silicon solar cells may be increased by the inclusion of p^+/n^+ tunnel junctions of highly doped GaP between the component cells. The relatively low recombination velocity at the GaP junction is the principal reason for recommending this material.

Recombination losses reduce the efficiency of multiple-junction cells with silicon p^+/n^+ tunnel junctions, where the interface recombination velocity is about 10^6 cm/s. In a GaP p^+/n^+ junction, however, the recombination velocity is expected to be lower by a factor of 10^3 or more (see figure).

GaP offers other advantages. Its lattice match with Si is good, so defects usually associated with lattice mismatches between layers are avoided. With a band gap of 2.3 eV, the GaP layers form a high barrier to minority carriers diffusing to the p^+/n^+ interface, resulting in a nearly zero theoretical tunneling probability for such carriers. The relatively wide band gap also helps to

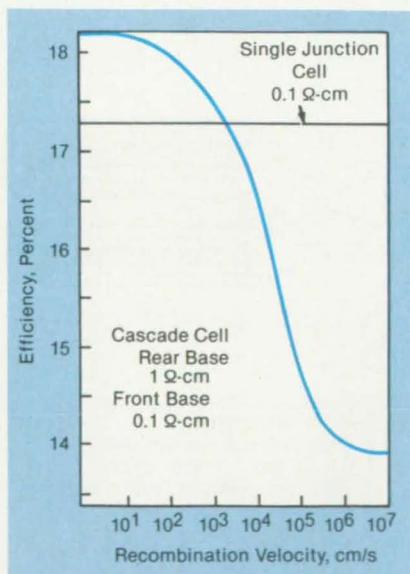

The Efficiency of a Typical Cascade Solar Cell, as estimated theoretically, is compared to that of a typical single-junction cell. If the recombination velocity can be made low enough, the cascade cell will be more efficient.



BENDIX FREE FLEX® PIVOTS FRICTION-LESS ANGULAR TRAVEL BEARINGS

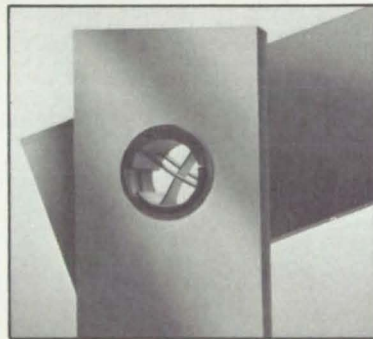
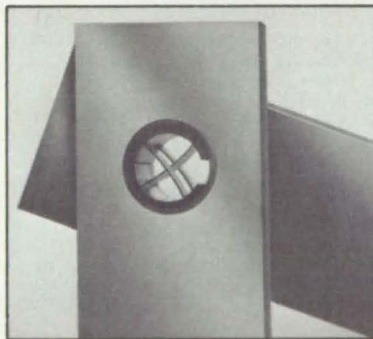

This patented pivot fills needs that lubricated bearings can't meet. With no required lubrication, operation in a vacuum or super clean area is possible. No rubbing surfaces permit the pivot to operate in unclean atmosphere and eliminate disadvantages of fretting and stiction. Its radial design provides low hysteresis, center shift and thermal drift. Operating through springs with low cyclic stress, indefinite life can be obtained making the pivot ideal for those hard to get at critical areas of your design.

Some typical applications are: oscillating mirrors, lever linkages, instrument nulling, weighing machines, bearing preloading, gimble rings, gyros, scanners, fuel controls, pressure and vibration transducers, etc.

With either cantilever or double ended support configuration, the Free Flex® Pivot has answered many difficult engineering requirements where reliable long-life angular travel is necessary.

When asked, "What do you like the most about Free Flex® Pivots?," engineers answer, "THEY WORK!"

Distributors located throughout United States and Europe maintain a stock of pivots from 1/8" diameter to 1" diameter. For more information contact:

Manager Flex Pivot, Marketing
Allied Corporation
Bendix Fluid Power Division
211 Seward Avenue, P.O. Box 457
Utica, NY 13503



increase efficiency by reducing optical losses.

This work was done by Taher Daud and Akaram Kachare of Caltech for NASA's

Jet Propulsion Laboratory. For further information, Circle 15 on the TSP Request Card.

Inquiries concerning rights for the com-

mercial use of this invention should be addressed to the Patent Counsel, NASA Resident Office-JPL [see page 21]. Refer to NPO-16526.

Advanced IPV Nickel/Hydrogen Cell

Expansion and contraction of the electrode stack are accommodated to increase cycle life.

Lewis Research Center, Cleveland, Ohio

Advanced designs for individual-pressure-vessel nickel/hydrogen cells have been conceived that should improve the cycle life at deep depths-of-discharge. Three features of the designs that are new and not incorporated in either of the contemporary cells are (1) the use of alternate methods of oxygen recombination, (2) the use of serrated-edge separators to facilitate the movement of gas within the cell while still maintaining required physical contact with the wall wick, and (3) the use of an expandable stack to accommodate some of the nickel electrode expansion. The designs also consider electrolyte volume requirements over the life of the cells and are fully compatible with contemporary designs.

As part of an overall effort to advance

the technology of nickel/hydrogen batteries for possible use in an energy-storage system, in low Earth orbit (LEO), improved advanced designs for individual-pressure-vessel (IPV) cells have been conceived. Contemporary IPV nickel/hydrogen cell designs and the results of cycle-life tests conducted in-house and by others were reviewed to identify areas where improvement could result in a longer cycle life. A component-improvement effort directed toward the physical properties of each of the individual components was initiated, and improvements were factored into the cell. Design philosophies have been developed related to oxygen- and electrolyte-management requirements. Existing technology was utilized where possible to minimize development

cost and time.

The contemporary-design cells are adequate for the geosynchronous-orbit (GEO) applications, where not many cycles are required over the life of the storage system. However, for the demanding LEO applications, the current cycle life at deep depths-of-discharge (2,000 to 8,000 cycles) is not acceptable. Some investigators report that this limited cycle life is mainly due to degradation of the nickel electrode. However, there are also indications that other modifications to the contemporary designs should result in an improved cycle life.

Some possible causes of degradation are (a) density changes of the active material during cycling that could cause fatigue of the nickel plaque and structural

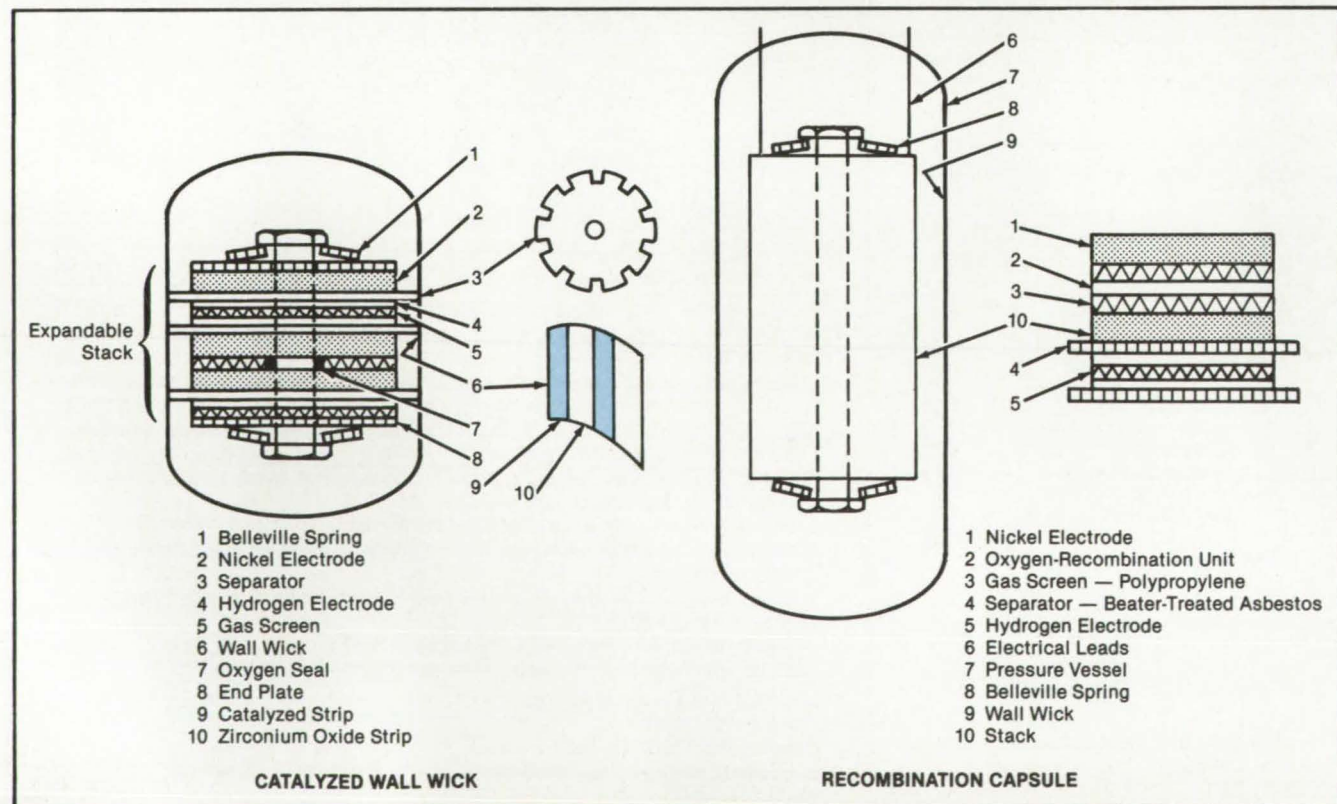

The **Advanced Nickel/Hydrogen Cells** include expandable electrode stacks. The two types shown here differ in the method of oxygen recombination.

damage to itself resulting in capacity loss, and (b) active material could flake or extrude from the electrode causing a loss of capacity and possible shorting of the cell. The extrusion of active material may also cause the channeling of oxygen generated during charge. This could lead to "popping" caused by large concentrations of oxygen reacting with hydrogen at the hydrogen electrode that could damage the electrode.

Blistering of the nickel electrode during cycling could cause capacity loss. Changes in pore distribution and electrode surface area can also result from active material expansion and contraction, which could affect electrolyte distribution and performance. It has been reported that the nickel electrode expands significantly during cycling. This could cause compression of the separators, drying of the stack, rupture of the polysulfone core, and cell failure. This failure mode can be eliminated by modifying the cell design to accommodate expansion.

Two different but similar advanced-design IPV nickel/hydrogen cells have been conceived. They are illustrated in the figure. One is referred to as the catalyzed wall wick; and the other, as the recombination capsule design. They differ only in the method of oxygen recombination. Initially the nickel electrodes, hydrogen electrodes, gas screens, pressure vessel, and potassium hydroxide electrolyte concentration will be identical to the ones used in the state-of-the-art.

The three features of the advanced designs that are new and not incorporated but fully compatible in either of the contemporary cells are (1) the use of alternate methods of oxygen recombination, (2) the use of serrated-edge separators, and (3) the use of an expandable stack. The designs also consider electrolyte volume requirements over the life of the cells and are fully compatible with state-of-the-art designs. Cells of these design variations should improve performance, life, and usable energy leading to lighter storage devices for low Earth-orbit applications for commercial or government applications.

This work was done by John J. Smithrick, Michelle A. Manzo, Olga Gonzalez-Sanabria and Daniel G. Soltis of Lewis Research Center. Further information may be found in NASA TM-83643 [N84-23025/NSP], "Advanced Designs for IPV Nickel Hydrogen Cells" [\$7]. A copy may be purchased [prepayment required] from the National Technical Information Service, Springfield, Virginia 22161.

Inquiries concerning rights for the commercial use of this invention should be addressed to the Patent Counsel, Lewis Research Center [see page 21]. Refer to LEW-13969.

How will today's events affect your project tomorrow... next week...next month?

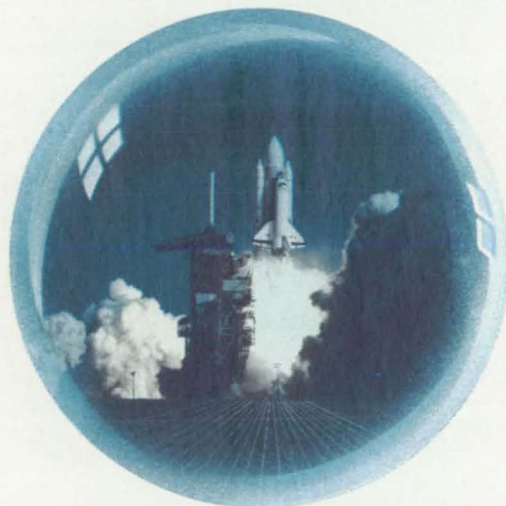

With VIS10N you'll know today!

Shortages, design changes, labor problems, interest fluctuations, delays... these are problems you face every day. How will they impact your project? Your schedule? Your budget?

Waiting for answers can be expensive... even disastrous. You need information to make decisions today so your project will be running smoothly tomorrow, next week, next month.

You need VIS10N... a powerful, comprehensive, easy-to-use project management system.

With VIS10N, your schedule can be updated as soon as events happen. You

can see how changes will affect your project every day. VIS10N's powerful "What-If" capability will help you analyze problems... more important, find solutions.

Put an end to surprises... send for more information on VIS10N today. Better yet, give us a call and find why so many of the Fortune 1000 companies depend on VIS10N.

SYSTONETICS

801 E. Chapman Ave., Fullerton, CA 92631
(714) 680-0910 • Telex 692-327

*VIS10N is available on DEC VAX and PRIME minicomputers.
VIS10Nmicro now available on IBM® PC.*

DOMESTIC OFFICES: Fullerton, CA (714) 680-0910 • San Jose, CA (408) 275-0890 • Seattle, WA (206) 455-3374 • Denver, CO (303) 740-6681 • Houston, TX (713) 461-3905 • Atlanta, GA (404) 955-7740 • Oakton, VA (703) 359-2982
INTERNATIONAL AGENTS: EURO/LOG HOUSE, 25 High Street, Rickmansworth, Herts WD3 1DF, United Kingdom, Phone 923-777007, Telex: 917099 • Software Solutions Pty, Ltd., 5 Alexander Street, Crows Nest, New South Wales, Australia 2065, Phone: 2-439-3055, Telex: AA72618.

IBM is a trademark of International Business Machines Corporation

Are you reading someone else's copy of NASA Tech Briefs?

**Qualified engineers
and other new
product
development
personnel can
receive their own
personal copies of
NASA Tech Briefs
by checking the
subscription box
and filling in one of
the bound-in cards.**

Electronic Systems

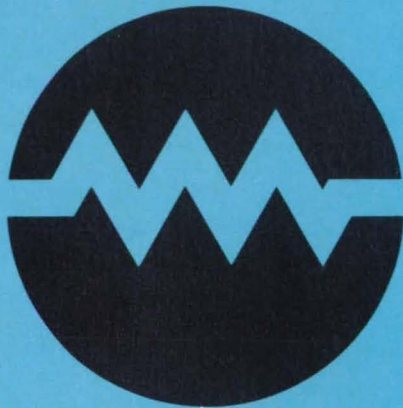

Hardware, Techniques, and Processes

- 56 In-Flight Simulator for IFR Training
- 58 Timed Multiple-Laser Array
- 60 Detector Arrays With Image-Plane Processing
- 61 Economical Video Monitoring of Traffic
- 62 Integrated-Circuit Active Digital Filter
- 64 Intermediate-Frequency-to-Video-Band Converter
- 65 Hardware/Software Expansion of Display Terminal and CPU
- 65 Pseudolog Digital-to-Analog Converter
- 67 Microwave Sensor Measures Turbopump Speed

Books & Reports

- 67 Simulating Single-Event Upsets in Bipolar RAM's
- 68 Plasma Source for Charge Control
- 68 Single-Event Upsets Caused by High-Energy Protons
- 69 Hyperspectral Infrared Images of Terrain

In-Flight Simulator for IFR Training

A computer-controlled unit feeds navigation signals to airplane instruments.

John F. Kennedy Space Center, Florida

An electronic training system allows students to learn to fly according to instrument flight rules (IFR) in uncrowded airspace. The new system (see figure) is a self-contained IFR simulator that is carried aboard the training plane. It generates signals and commands for the standard instruments on the airplane, including a navigational receiver, distance-

measuring equipment, an automatic direction finder, a marker-beacon receiver, an altimeter, an airspeed indicator, and a heading indicator.

A training session usually begins on the ground at a remote airport. The student and instructor load a simulation program and data from a tape cassette into a microcomputer in the system. They take

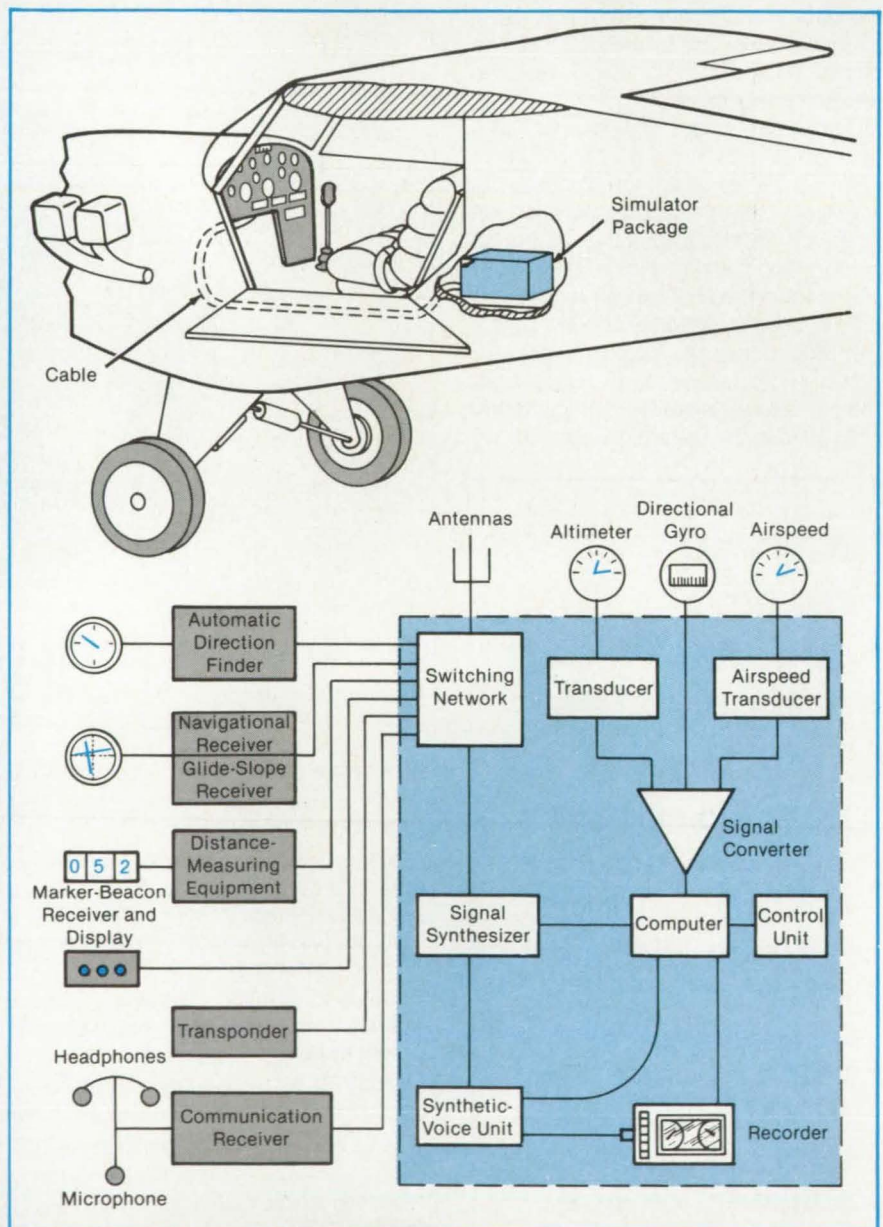

The IFR Simulator is contained in a compact, lightweight package on a training airplane. The simulator provides simulated inputs to standard navigation and instruments. A switching network routes simulated signals to the proper equipment and disconnects the equipment temporarily from antennas.

"FREE ENTERPRISE ISN'T FREE.



"IT NEEDS YOUR SUPPORT."

Andrew C. Sigler,
Chairman and CEO,
Champion International Corp.

I'm a volunteer supporter of the International Executive Service Corps, a not-for-profit organization with a vital mission:

We build free enterprise worldwide by sending retired U.S. executives to help companies in developing countries. The executives receive expenses, but no salary.

Our main purpose is to help developing countries succeed in business. But the benefit doesn't stop there. These countries consume about

40 percent of U.S. exports.

With the support of over 800 U.S. companies, we have completed 9,000 projects in 77 countries. Our Board of Directors and Advisory Council include the CEOs of many of America's largest companies.

Join me in building free enterprise throughout the free world. Write to: Andrew C. Sigler, Chairman and CEO, Champion International Corp. at P.O. Box 10005, Stamford, CT 06904-2005.



International Executive Service Corps

It's not just doing good. It's doing good business.

**Ad
Council**
A Public Service of
This Publication

out the navigation and approach charts for the simulation. They take off and proceed to the altitude of the simulated airport at 500 to 1,000 ft. (150 to 300 m) above the local terrain where the simulation begins.

Under the control of the microcomputer, a voice synthesizer clears the plane for the simulated takeoff and directs the student to maintain a designated heading. The student then proceeds to fly a predetermined course. Meanwhile, the microcomputer continually provides updating signals appropriate to the changing simulated position to the navigation instruments.

The voice synthesizer issues messages along the way. For example, it tells the student to change frequency when

the plane enters another simulated traffic-control area. If the pilot strays from the preplanned course, the synthesizer delivers an error message, just as a real air-traffic controller would. The training session ends when the plane lands at the simulated airport; a simulated missed-approach procedure can be included in the landing.

The system can be stopped during a training session so that the instructor can explain an error. Voice commands can be stopped while position integration continues so that the student can practice a procedure such as maintaining a holding pattern.

A key component of the system is a signal synthesizer, which generates a variety of signals like those that would normally be

received by the navigational receivers. During a simulation, the microcomputer disconnects the navigational receivers from their antennas so that they can receive the simulated input signals along the simulated route.

This work was done by Loyd C. Parker of Kennedy Space Center. For further information, Circle 46 on the TSP Request Card.

This invention has been patented by NASA (U.S. Patent No. 4,490,117). Inquiries concerning nonexclusive or exclusive license for its commercial development should be addressed to the Patent Counsel, Kennedy Space Center [see page 21]. Refer to KSC-11218.

Timed Multiple-Laser Array

Pulse power, frequency, and shape would be variable and combined to suit particular applications.

NASA's Jet Propulsion Laboratory, Pasadena, California

A versatile laser system would combine high power with high efficiency, long life, and low cost. The proposed system would consist of an array of excimer lasers fired under microcomputer control. When fired in unison, the array would produce a high-power pulse at a higher efficiency than would otherwise be possible. When fired in sequence, the array would produce pulses at a high rate without unduly stressing components and shortening their lives (see figure).

The array would be made of several modules, each module being an inert gas/halogen laser excited by an electrical pulse. Such an array would have a variety of important uses. Metal welding by laser, for example, requires microsecond pulses to melt the material at joints. A single excimer laser cannot produce such a long pulse; the maximum pulse width would be about 200 nanoseconds. However, 10 excimer lasers fired in sequence, without pause, in 100-nanosecond pulses would produce an effective pulse length of 1 microsecond.

Alternatively, such an array could be operated with intervals between pulses to produce a series of energy bursts at high average power. Ten lasers operating at 100 hertz in a synchronized firing sequence would produce an output at 1 kilohertz. The array could be cheaper and more efficient than a single laser generating the same average power at the same high pulse rate.

Such other applications as solar-cell annealing require a single high-energy pulse of ultraviolet light for a short duration. For example, a solar cell 100 square centi-

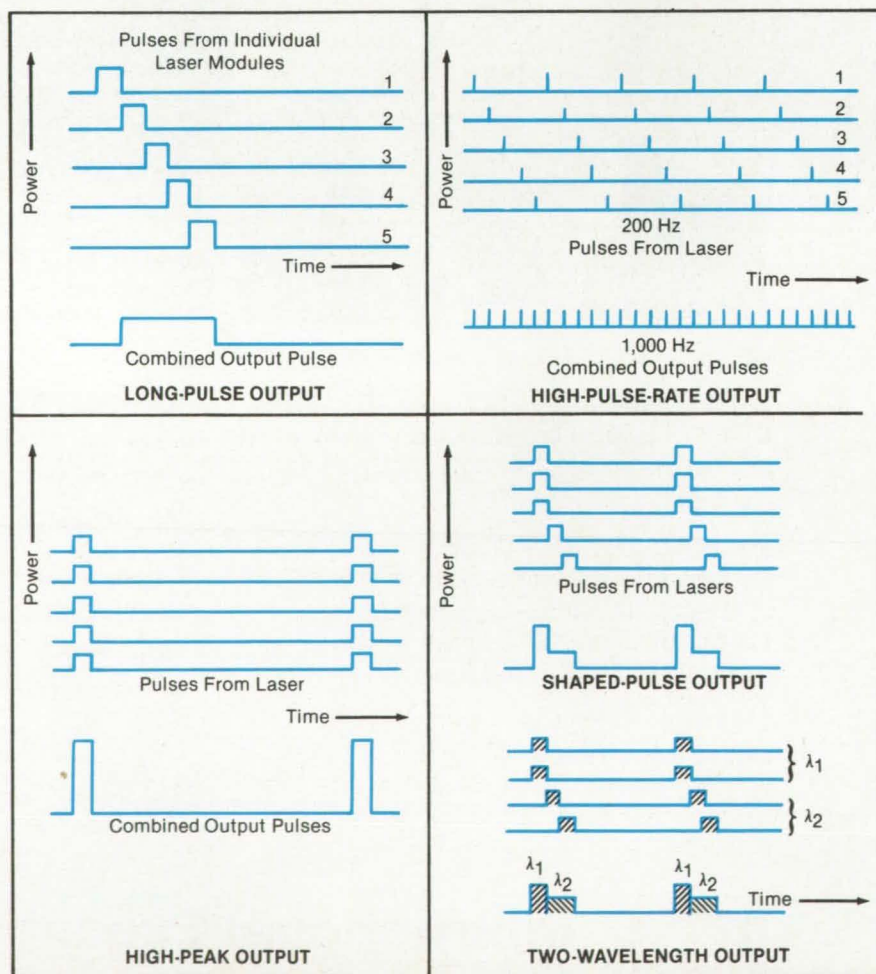

Pulses From the Individual Lasers in an array can be combined in various ways to suit a particular application. Examples illustrated here are for a five-laser array. A microcomputer would control the electrical signals that fire the lasers.

meters in area requires a 150-joule beam, 10 by 10 centimeters in cross section, for 50 nanoseconds for annealing in a single pulse. Designing a single laser for this application would be a formidable engineering challenge, but 10 lasers simultaneously producing 15 joules could do the job.

The firing of the lasers in the array could be phased to shape the output pulse. For example, firing of 6 lasers in a 10-laser array could be followed immediately by firing of the remaining 4, producing a fast-rising, slowly falling output pulse. This kind of pulsing would be useful in cutting and drilling.

An excimer array could also be used to enhance the operation of another type of laser. For example, carbon dioxide lasers are powerful and efficient, but are not effective in cutting metals that absorb infrared radiation only slightly. However, if an excimer array were fired so that its pulses would immediately precede those from a

carbon dioxide laser, it would melt the metal surface and reduce its infrared reflectivity so that the carbon dioxide laser could then cut more effectively.

An important advantage of a laser array is that if one of the lasers is not functioning, the system can continue to operate, albeit at reduced capacity. Moreover, there is a longer interval between part replacement and maintenance than for a single laser of equal capacity because components are operated more conservatively.

This work was done by James B. Laudenslager and Thomas J. Pacala of Caltech, for NASA's Jet Propulsion Laboratory. For further information, Circle 12 on the TSP Request Card.

Inquiries concerning rights for the commercial use of this invention should be addressed to the Patent Counsel, NASA Resident Office-JPL [see page 21]. Refer to NPO-16433.

Imagine.

Imagine a life spent wondering if, and when, a disease that destroys your body, your mind, your life will strike. That's the shadow under which every child of a Huntington's Disease victim lives. But now there's hope. Real hope.

Your contributions helped us find the marker, now they can help us find a cure. Please give generously to the National Huntington's Disease Association.

NATIONAL HUNTINGTON'S DISEASE ASSOCIATION

National Huntington's Disease Association
1182 Broadway, Ste. 402, NY, NY 10001

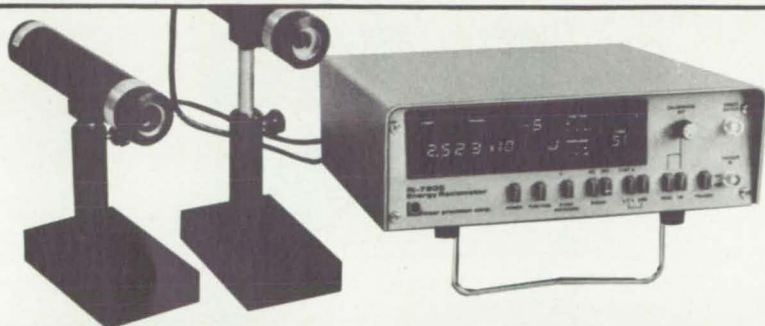

PULSED ENERGY MEASUREMENT

*"unsurpassed for speed, sensitivity, & accuracy
... UV to Far IR, picojoule to joules"*

Rj-7000 SERIES microprocessor based ENERGY METERS, available in single or dual channel readout. Features scientific notation readout, autoranging, BCD output, EMI rejection, and wide dynamic range. Direct readout of individual pulse energies with repetition rates up to 40pps and pulse length from picoseconds to one millisecond. The measurement range is from 10^{-9} to 10 joules (pyroelectric), down to 10^{-13} with the silicon probe. A broad selection of probes are available to meet your requirements.

PROBE SPECIFICATIONS (with either readout)

MODEL	TYPE	AREA	RESOLUTION*	MAX. SIGNAL	SPECTRAL RESPONSE
Rjp-734	Cavity	5.0cm ²	1×10^{-5}	$1 \times 10^6 \text{W/cm}^2$	$\pm 1/2\%$ (0.4-3 μm); $+1/2\%$, -4% (0.25-16 μm)
Rjp-735	Cavity	1.0cm ²	1×10^{-7}	$1 \times 10^6 \text{W/cm}^2$	$\pm 1/2\%$ (0.4-3 μm); $+1/2\%$, -4% (0.25-16 μm)
Rjp-736	Flat	20.0cm ²	1×10^{-4}	$1 \times 10^6 \text{W/cm}^2$	$\pm 3\%$ (0.4-1 μm); $+3\%$, -9% (0.35-11 μm)
Rjp-765	Silicon	1.0cm ²	5×10^{-13}	5W/cm ²	0.3-1.1 μm (not flat)

*Single event, 10X and 100X averaging available

from the leader
in optical radiation
measurements.....



For more information, contact:

laser precision

1231 Hart Street, Utica, NY 13502 (315) 797-4449

FREE!

Radiometric Selection GUIDE

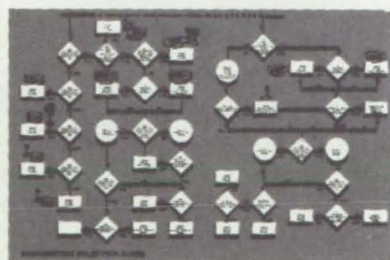

The easy way to select the right power meter, energy meter, radiometer, or detector to fit your requirements.

(UV to far IR, picowatt to kilowatt, picojoule to joules)



CIRCLE NO. 302

Detector Arrays With Image-Plane Processing

Image detection and edge processing are merged on the same VLSI chip.

Langley Research Center,
Hampton, Virginia

Previous approaches to machine vision have concentrated on special-purpose computational hardware, including focal-plane processor chip technologies. In most cases, detection and processing are considered as distinct submodules. In a newly proposed device, edge processing of picture elements is incorporated on the same VLSI (Very-Large-Scale Integration) chip as that of the image-detection elements.

The concept combines relatively large detector elements with small processor elements as VLSI chip features and can have many specific embodiments. Previous VLSI and VHSIC (Very-High-Speed Integrated Circuit) processor-chip designs have generally sought to diminish all individual features on the chip to the smallest size possible and have not merged detection with processing. The new device concept retains relatively large detector element sizes (perhaps 10 to 100 μm or larger in diameter) with processing-electronics components of much smaller size (2 μm or less), filling in gaps left between the detector-element active areas.

The specific design concept shown schematically in the figure is for realizing a difference-of-Gaussian (DOG) operator in a detector/processor array for use in machine-vision edge-enhancement and edge-detection applications. A sequential approach to input voltages and readout is shown, but a parallel approach is also possible if readout and voltage distribution points feed through to the base of the substrate material.

The principal functional components

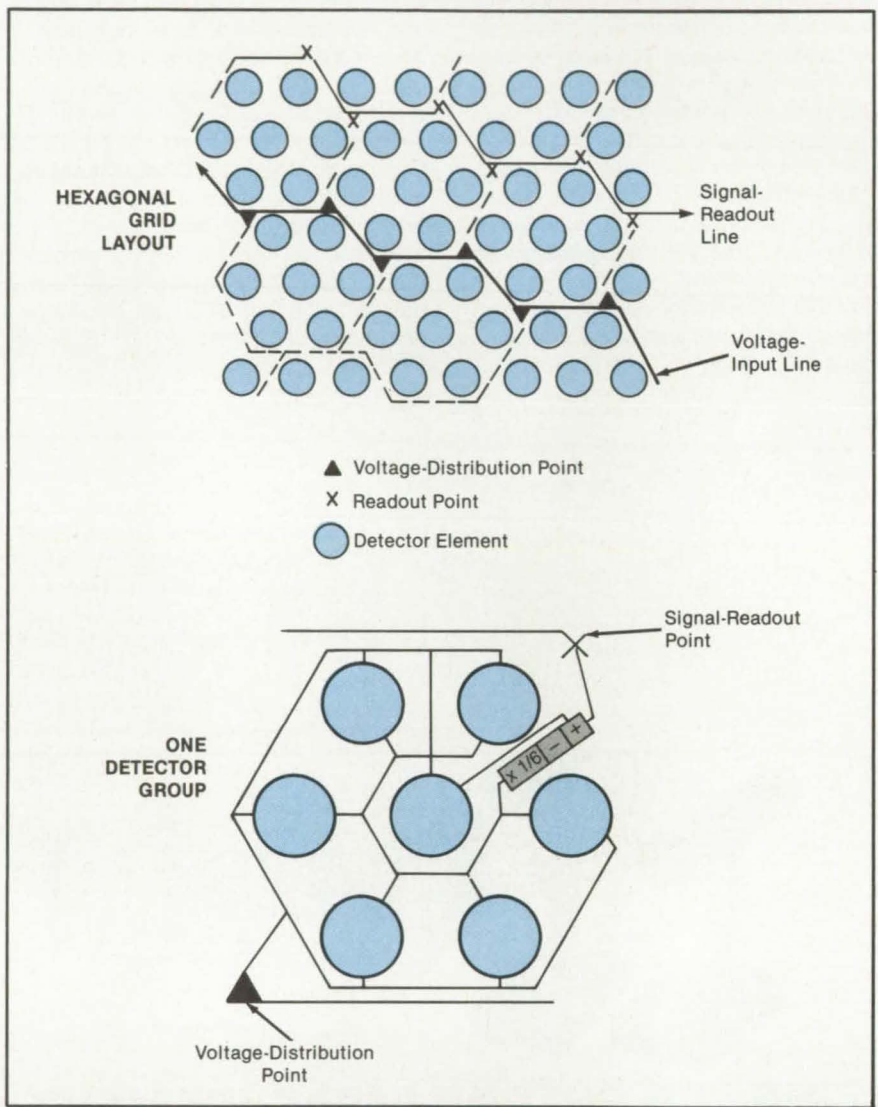

The **Detector-Array Device** would help to perform the difference-of-Gaussian operation for use in machine-vision edge enhancement and edge detection.

1	Exxon	25	Standard Oil (Ohio)
2	General Motors	26	AT&T Technologies
3	Mobil	27	Boeing
4	Ford Motor	28	Dow Chemical
5	IBM	29	Allied
6	Texaco	30	Eastman Kodak
7	E.I. du Pont	31	Unocal
8	Standard Oil (Ind.)	32	Goodyear
9	Standard Oil of Cal.	33	Dart & Kraft
10	General Electric	34	Westinghouse Elec.
11	Gulf Oil	35	Philip Morris
12	Atlantic Richfield	36	Beatrice Foods
13	Shell Oil	37	Union Carbide
14	Occidental Petroleum	38	Xerox
15	U.S. Steel	39	Amerada Hess

27 million
Americans can't read.
And guess who pays the price.

Every year, functional illiteracy costs American business billions. But your company can fight back...by joining your local community's fight against illiteracy. Call the Coalition for Literacy at toll-free **1-800-228-8813** and find out how. You may find it's the greatest cost-saving measure your company has ever taken.

A literate America is a good investment.

for creating a DOG operator are the inversion and attenuation of the signals from the six detector elements surrounding the central element and the summation of various signal contributions for readout. The attenuation factor is about one-sixth for the six surrounding elements. A lens-blur function smooths the detector-element spatial response to obtain approximately a DOG-group re-

sponse function and minimizes the effect of gaps between adjacent detector elements.

This work was done by Daniel J. Jobson of **Langley Research Center**. Further information may be found in NASA TM-85809 [N84-25927], "Edge Analyzing of Center/Surround Response Functions in Cybernetic Vision" [\$8.50]. A copy may be purchased [prepayment re-

quired] from the National Technical Information Service, Springfield, Virginia 22161.

Inquiries concerning rights for the commercial use of this invention should be addressed to the Patent Counsel, Langley Research Center [see page 21]. Refer to LAR-13391.

Economical Video Monitoring of Traffic

Data compression allows video signals to be transmitted economically on telephone circuits.

NASA's Jet Propulsion Laboratory, Pasadena, California

A video system with television cameras positioned at critical points on highways allows traffic controllers to determine visually, almost immediately, the exact cause of a traffic-flow disruption; e.g., accidents, breakdowns, or spills, almost immediately. The controllers can then dispatch

appropriate emergency services and alert motorists to minimize traffic backups.

The system (see figure) incorporates data compression so that 9,600-baud telephone lines can be used to carry video signals. Such costly wideband com-

munication links as coaxial cable, light guide, or microwave transmission are not needed. The new system produces pictures of adequate quality and at sufficiently high rates so that problems on roads are readily noticed and identified. An analysis has shown that the costs of

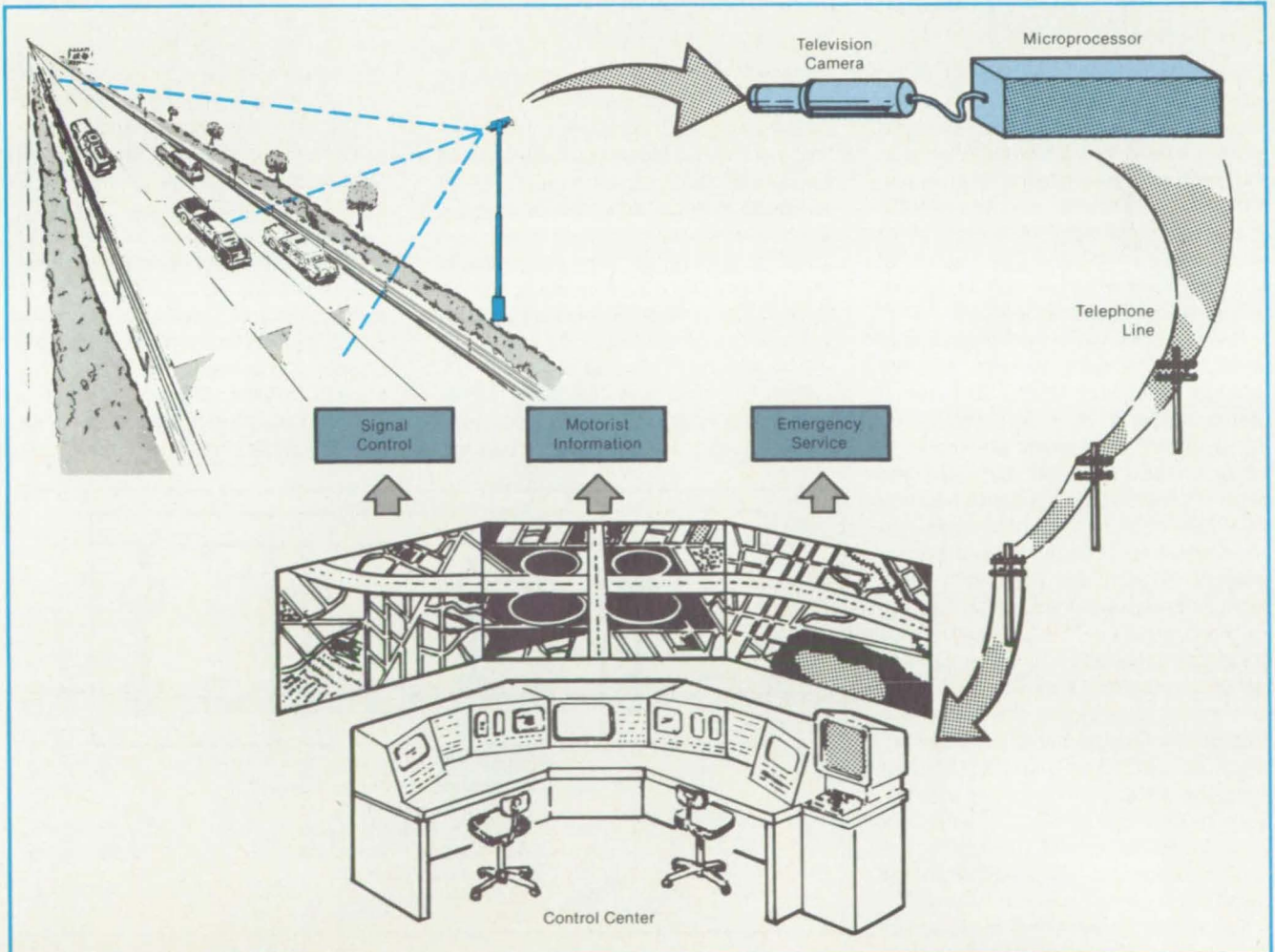

Telephone Lines Transmit Television Signals to a remote traffic-control center. The lines also carry command signals from the center to the TV camera and compressor at the highway site.

operating this system could be substantially less than for a system with wideband transmission, even with the inclusion of data-compression equipment for the narrow-band system.

A field test of a prototype system was conducted by NASA's Jet Propulsion Laboratory and a private organization in cooperation with the Maryland Department of Transportation (MDOT). A television camera with remote pan, tilt, and zoom controls was erected at the intersection of Interstate Highway 695 (the Baltimore Beltway) and Interstate 70. Video images were transmitted via telephone lines to MDOT offices in Glen Burnie, about 10 miles (16 kilometers) away.

The system uses data-compression and error-suppression techniques similar to those used to transmit television images from interplanetary spacecraft to Earth. One of the most attractive features

of these techniques for traffic applications is that an operator can vary the compression and the corresponding picture quality and frame rate at the remote control center.

At the highway site, the system converts the camera image into a 256-by-256 array of 8-bit numbers. It subjects this numerical representation of the picture to a series of parallel transformations designed to alter its statistical properties and suppresses enough data to produce frames at the rate designated by the operator. The telephone channel carries the coded picture to the receiving subsystem at the control center. There, the process used to compress the picture for transmission is reversed, and the original picture is reconstructed as closely as possible.

Using the remote TV camera controls, the operator scans the field of view at a

high frame rate to locate problems on the highway. Once a problem is spotted, the operator reduces the frame rate and thereby improves the image quality to identify the type of problem. The transmission time for an uncompressed image at full resolution is 51 seconds. With compression, useful transmission times range from about 0.3 seconds per frame for vehicle counting and speed detection to 7 seconds per frame for problem identification.

This work was done by Bradford C. Houser, Garrett Paine, Louis D. Rubenstein, and O. Bruce Parham, Jr., of Caltech for NASA's Jet Propulsion Laboratory and William Graves of Dalmo Victor, Textron, and Cedric Bradley of MDOT. For further information, Circle 43 on the TSP Request Card. NPO-16473



Integrated-Circuit Active Digital Filter

Pipeline architecture with parallel multipliers and adders speeds calculation of weighted sums.

NASA's Jet Propulsion Laboratory, Pasadena, California

New digital integrated-circuit chips with pipeline architecture rapidly move 35×35 two-dimensional convolutions. There is a need for such circuits in image enhancement, data filtering, correlation, pattern extraction, and synthetic-aperture-radar image processing, all of which require repeated calculations of weighted sums of values from images or two-dimensional arrays of data.

Q set of chips (each containing a one-by-five set of multiplier/adders) can serve as a fast digital filter when attached to a host computer. In an $m \times n$ digital filter, for example, processing an image of $1,000 \times 1,000$ elements, each element value is replaced by a weighted sum of the values of an $m \times n$ rectangular subarray of elements centered on the given element. For this new hardware, each value and each weight are fetched from memory only once. First the $m \times n$ array of weights is loaded into the filter, where it remains throughout the calculation. Then the image data are shifted into and through the filter as the filtered element values are calculated. A general-purpose computer would perform the same calculation much more slowly: Each element value would be fetched from memory $m \times n$ times, once for each element of the weighting subarray in which it appears.

Each chip contains five multiplier/adders executed in metal-oxide semiconductor circuitry. A delay-adder modular design (see figure) provides a "bucket-

brigade" transfer of the accumulated product sum, thereby saving multiple accesses to the host computer memory. As many of these chips as necessary can be cascaded together to form an array containing $m \times n$ multipliers. Delay lines are used to retain data between use in succeeding rows of the filter. For example, one row of a 35×35 filter would require seven chips. The chips for one such row will fit in one 68-pin flatpack 3.5 by 1.5 in. (90 by 40 mm) in dimension.

Both the data and the sums move through the chip in a pipelined manner. Each of the 1,225 multiplications and ad-

ditions taking place at any given moment contributes to a different weighted sum.

This work was done by Robert Nathan of Caltech for NASA's Jet Propulsion Laboratory. For further information, Circle 37 on the TSP Request Card.

Title to this invention has been waived, under the provisions of the National Aeronautics and Space Act [42 U.S.C. 2457(f)], to the California Institute of Technology. For further information regarding nonexclusive or exclusive licensing, contact Edward O. Ansell, Director of Patents and Licensing, 307 Keith Spalding Building, Pasadena, CA 91125. Refer to NPO-16020.

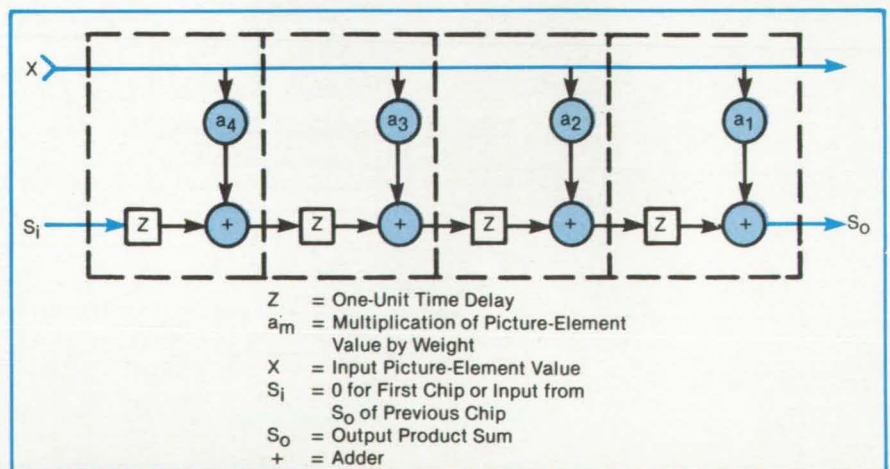

Picture-Element Values and Partial Sums flow through delay-adder modules like this one. After each cycle or time unit of the calculation, each value in the filter moves one position to the right.

AFTER 35 YEARS AS HIS EMPLOYER, TELL HIM ABOUT DIRECT DEPOSIT AS A FRIEND.

Make sure the people who have given you so much through the years get everything they've got coming in the years ahead.

Direct Deposit lets your retiring employees send their Social Security straight to their checking or savings account. It's free, and it lets them enjoy the good life they deserve.

As an employer, send for a free Direct Deposit retirement planning kit today, and pass the information along...to a friend.

Write to—Direct Deposit (D1),
U.S. Treasury, Annex 1, PB-1100,
Washington, DC 20226.



DIRECT **DEPOSIT**



A Public Service of This Publication & The Advertising Council

United States Treasury



Intermediate-Frequency-to-Video-Band Converter

Analog and digital circuits are combined to frequency-convert from intermediate frequencies directly to video-band frequencies to meet stringent requirements.

NASA's Jet Propulsion Laboratory, Pasadena, California

A hybrid analog-to-digital frequency downconverter (see figure) directly converts high intermediate frequencies (IF's) of the receiver directly to video-band frequencies (VF's) with features of high image-band rejection (>34 dB) and phase variations less than peak (about the average phase response) across 80 percent of the passband. The downconversion from the IF's to near-zero-frequency video-band output frequencies, with good adjacent image-band rejection, is achieved by use of the phase cancellation technique that has been applied in single-sideband rejection of modulated radio frequencies.

Downconversion to VF to near-zero frequency must overcome the problem of adjacent band signals and noise foldover into the desired passband. The desired

passband can be either the upper or the lower spectrum immediately around the local-oscillator frequency, which can be set anywhere within the IF range. This conversion method (see figure) allows downconverting of any bandwidth-limited segment of the entire IF band without degrading the received signal-to-noise ratio.

As shown in the figure, two quadrature signals from the local oscillator are mixed with two IF input signals and downconverted to video-band near-zero frequency. These video-band signals are frequency-band limited by antialiasing low-pass filters (LPF's) prior to input to the digital circuits. These LPF's prevent unwanted interference signals (aliasing), generated in the digitization process, from appearing in the desired video passband.

The digital circuits perform the remaining function of phase shifting all frequencies by 90° , from one downconverted mixer output, combining these shifted frequencies with the other mixer output frequencies, and finally low-pass filtering after digitizing the analog input signals by the analog-to-digital converters. The 90° phase shifting over the range of the video frequencies and the final low-pass filtering were achieved better with digital circuits to meet the stringent requirements of good image-band rejection and low phase variation within the passband.

Either the upper or the lower spectrum of the IF band about the local-oscillator frequency can be selected with equal band rejection of the other spectrum, depending upon the polarity of the comp-

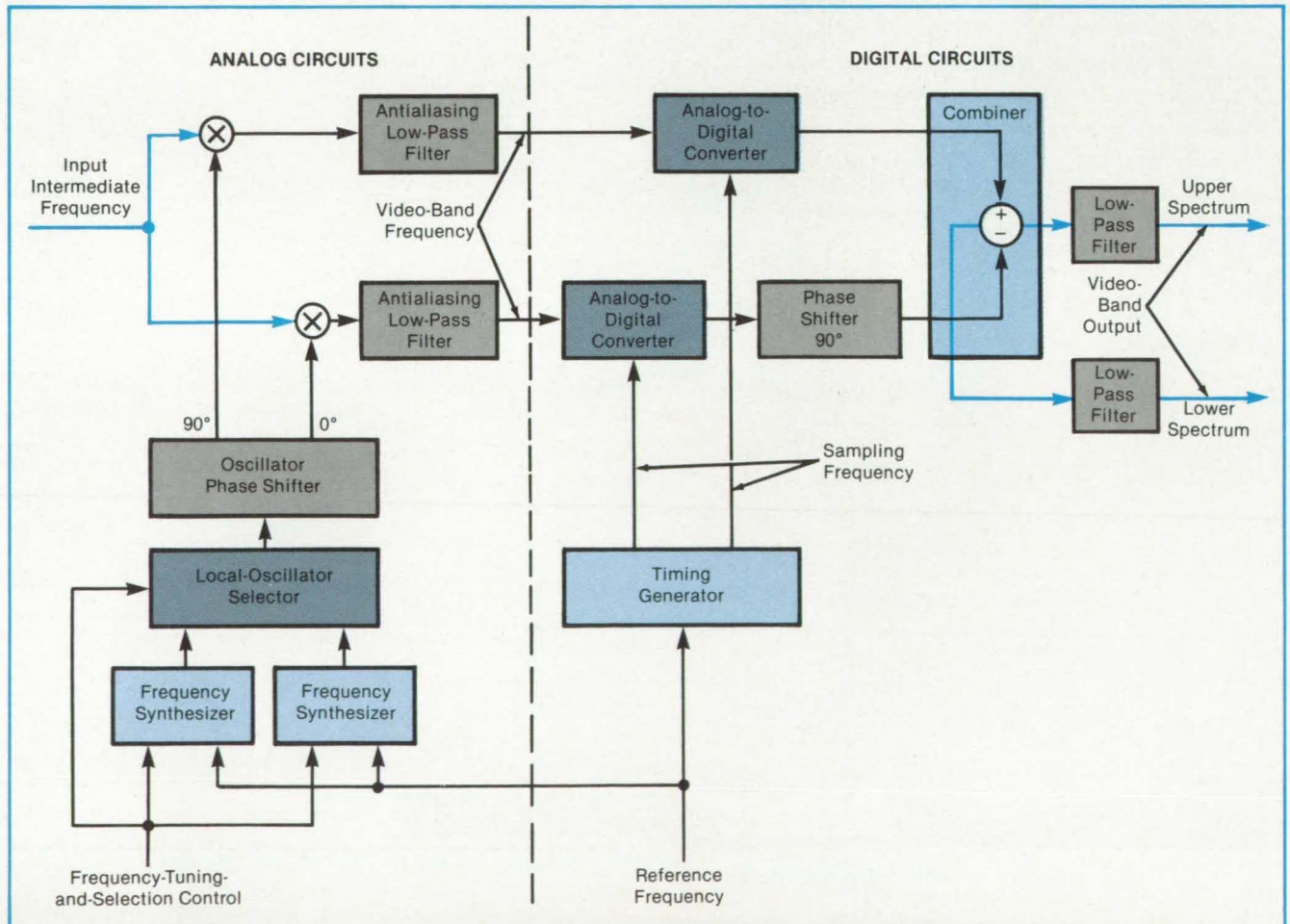

This IF-to-Video-Band Converter operates on the principle of signal-band cancellation in phase-quadrature circuits. It can downconvert intermediate frequencies directly to video-band frequencies to near-zero frequency with good image-band rejection and low phase variation within the passband.

bined output. Thus the downconversion of any band-limited segment of the IF band to video band, with the same image-band rejection and good phase-variation limitation, is available over a wide band of IF input signals. This is limited only by the

frequency range of the IF and local oscillators and the capability of providing two quadrature signals from the local oscillator over the frequency range.

This work was done by North C. Ham, Victor M. Chavez, Victor S. Chen, and

Takeshi Sato of Caltech for NASA's Jet Propulsion Laboratory. For further information, Circle 40 on the TSP Request Card.

NPO-16214

Hardware/Software Expansion of Display Terminal and CPU

An IBM PC coupling is used to expand the capabilities of an expensive special-purpose system.

Langley Research Center, Hampton, Virginia

The capabilities of a Tektronix digital processing oscilloscope (DPO) system used to process data from a molecular beam/mass spectrometer system were significantly expanded at low cost when the oscilloscope was coupled to an IBM personal computer (PC). The IBM PC (832K, 8-bit byte memory) was interfaced to the Tektronix CP1151 computer (32K, 16-bit word memory) through the teletype port of the Tektronix 4010-1 computer display terminal. An electronic interface was built to provide isolation, level shifting, and signal inversion between the IBM PC RS-232 port and the 4010-1 terminal teletype port. Modifications to the 4010-1 terminal were made to increase the teletype rate from 110 to 9,600 baud. Software for both computers was developed to give control of the DPO system to the IBM PC and to provide data/program file ex-

change between the two computers.

Three modes of operation are possible: standard operation of the DPO system, using the 4010-1 display terminal as the keyboard and control input; standard operation of the IBM PC; and linked operation, using the IBM PC and its keyboard as the control input to the DPO system. During linked operation, the IBM PC can be used simply as a remote display terminal for the DPO system, or the expansion capabilities of the IBM PC can be added to the DPO system.

The coupled system is a relatively inexpensive memory expansion of the DPO, which greatly exceeds that currently available from Tektronix. All software and hardware available for the IBM PC can be utilized with the DPO as needed. The IBM PC can be connected through a specially-designed transistor/transistor-logic-to-

teletype isolator/coupler interface to the Tektronix CP1151 computer teletype input/output. This eliminates the need for the 4010-1 display terminal (provided that a baud rate X16 clock is included). The increased limit for the number of mass-spectrometer data files that can be analyzed at one time with the coupled system offers a new level of flexibility. In general, this coupling demonstrates the utilization of low-cost microcomputer hardware and software to expand the capabilities of expensive special-purpose computer systems.

This work was done by Billy R. Adams of Kentron International, Inc., for Langley Research Center. For further information, Circle 84 on the TSP Request Card. LAR-13350

Pseudolog Digital-to-Analog Converter

The sensitivity decreases by 10 at the beginning of each input decade.

Lewis Research Center, Cleveland, Ohio

A method has been conceived to convert binary-coded data to a suitable linear form for strip-chart recording. As an example of the use of this method, the pressure level of high-vacuum facilities is typically monitored by means of a Bayard-Alpert ionization tube coupled with appropriate readout electronics. The typical vacuum range for these ionization gages is from 10^{-3} torr down to 10^{-10} torr (10^{-1} to 10^{-8} Pa). For vacuum-facility monitoring purposes, a strip-chart record of facility pressure as a function of time is frequently desired. Thus, most commercially available ion-

NASA Tech Briefs, January/February 1986

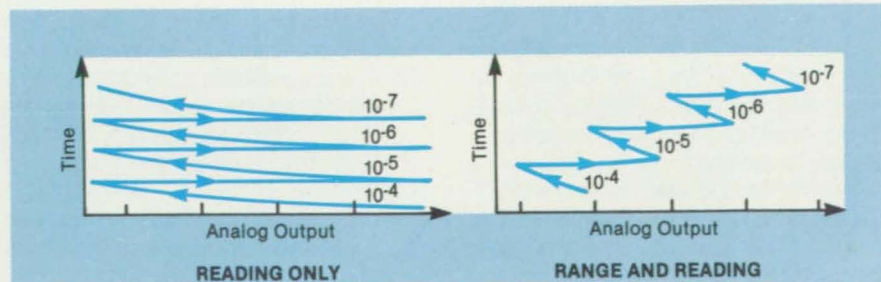

Figure 1. **Strip-Chart Recordings** like these would be obtained from typical pressure readings in a vacuum system during pumpdown. In the curve at the left, the BCD digital vacuum-gage output has been processed by the analog-to-digital converter in such a way that only the reading digits (but not the range) appear in the output. In the curve at the right, the range has also been converted to analog and placed as the most significant digit.

zation gages produce an analog output voltage that is proportional to the pressure. Depending on the specific instrument, the analog output may represent the "reading" only (for example, 5.2) with no information about the "range" (10^{-6}); or it may represent the logarithm of both. Newer instruments now make pressure data available in the form of binary-coded decimal (BCD) digits — two digits for the reading plus one digit for the range. Conversion of BCD data to an analog voltage signal is straightforward; there are many IC's on the market for this purpose.

The problem is what is the most suitable form for converting the BCD data to strip-chart recording. Figure 1 (left) shows a pumpdown trace in which the pressure starts at 1×10^{-3} torr (1.3×10^{-1} Pa) and decreases by a factor of 2 per unit time to 1×10^{-7} torr (1.3×10^{-5} Pa).

This sketch represents the analog conversion of only the reading digits. The change from one decade to the next is obvious, but from which range to which is unknown, unless the range is recorded on a second channel or entered manually on the chart. Figure 1 (right) shows the same pumpdown with the range also converted to analog and placed as the most significant digit. This trace is quite confusing at first sight. Convention leads one to expect the data to decrease in magnitude from right to left in a regular way, not decrease for a bit, then increase abruptly only to decrease again. This behavior is caused by the fact that the ranges are negative powers of 10, so that a larger range number is in fact a lower pressure.

To present the data in a more logical form, a pseudologarithmic digital-to-analog converter with the following characteristics is desired:

1. The analog output voltage increases as the pressure increases;
2. Each decade in pressure (range) is represented by an equal increment of voltage; and
3. Within each pressure decade, the reading digits are converted linearly (not logarithmically); that is, 5 is half the way between 1 and 10.

As shown in Figure 2, only the range digit needs to be manipulated before being converted into an analog voltage. First a suitable binary mask (see below) is applied to the range using a 4-bit binary adder. The masking addend is hard wired on the adder, and the carry bit is ignored. The outputs of the adder then become the inputs to a 4-bit bistable latch. When the ionization gage signals "data ready," the input bits of the latch are transferred to its outputs. The inverted outputs from the range latch are then used as the most significant digit (MSD) to a standard BCD digital-to-analog converter. The two digits

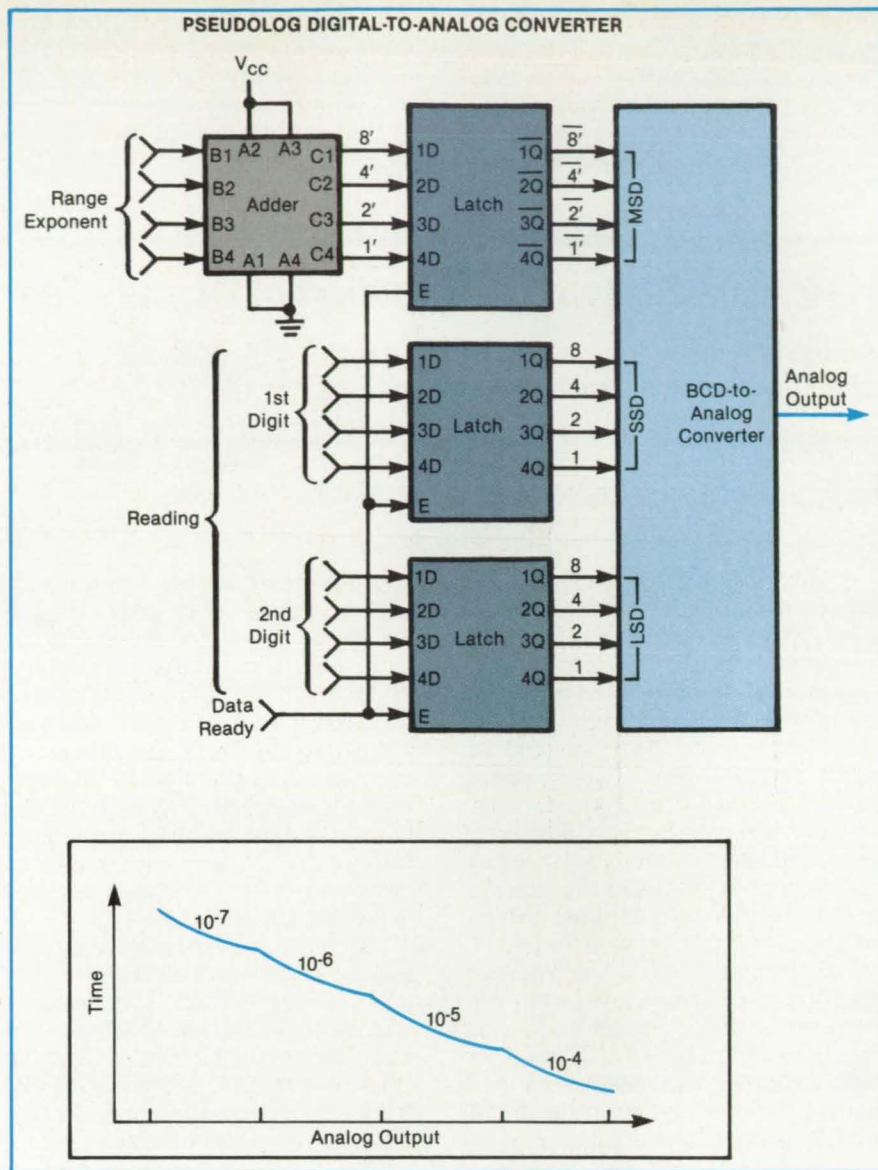

Figure 2. The Pseudolog Converter would produce a strip-chart recording with continuous analog coverage of the entire pumpdown pressure history. The ends (1, 10, 100, etc.) of the decades appear at equal voltage intervals in the output, but within each decade the output varies linearly with the input.

for the readings are also loaded into latches and become the second most (SSD) and least (LSD) significant digits for analog conversion. Figure 2 shows the same pumpdown as Figure 1, but seen through the eyes of the pseudolog converter.

The scalloped appearance is caused by the nonlogarithmic conversion of the reading digits; that is, 5 is halfway between 1 and 10, not seven-tenths of the way as it would be for true log conversion.

The binary mask for the range is selected to set the lowest decade to be converted; that is, which power of 10 is to appear as zero volts. For the circuit shown, the 10^{-9} dec-

ade falls between 0.00 and 0.99 volt, and the 10^{-8} decade runs from 1.00 to 1.99 volts. Full-scale (9.99) volts are 9.9×10^0 . The mask choice is simple; the sum of the lowest decade desired and the mask must be 15 in decimal (1111 in binary). In this case, 9 is 1001, so the required mask is 6 (0110). When their sum (1111) is inverted (0000) and passed to the converter, it appears as 0 volts. Similarly, for a lowest range of 10^{-7} , the mask is 8 (1000).

This work was done by Suzanne T. Gooder of Lewis Research Center. No further documentation is available. LEW-14219

Microwave Sensor Measures Turbopump Speed

The sensor does not perturb the flow and is immune to cavitation.

Marshall Space Flight Center, Alabama

A microwave device measures the rotational speed of a turbopump without obstructing the flow. In contrast, a magnetic or capacitive speed sensor protrudes into the flow in proximity to the rotating shaft, thereby disturbing the flow and risking damage to the sensor and the machine. While nonintrusive optical speed sensors are available, they do not operate correctly when the pumped fluid cavitates.

The microwave speed sensor is illustrated schematically in the figure. A microwave antenna in the pump housing sends a continuous signal to a lobed, reflective encoder nut on the rotating shaft. The signal returned to the antenna is modulated by the reflections from the passing lobes.

The returned signal is detected and low-pass filtered to extract the modulation, the frequency of which is proportional to the rotational speed. The filtered signal is fed to a pulse shaper. The shaped pulses are counted along with a timing pulse train to obtain the modulation frequency and, therefore, the rotational speed.

The microwave frequency must be selected so that cavitation in the pumped fluid has a negligible effect on the returned signal. For example, bubbles in nonane do not affect the microwave transmittance strongly at frequencies near 15 GHz, so that the sensor is insensitive to

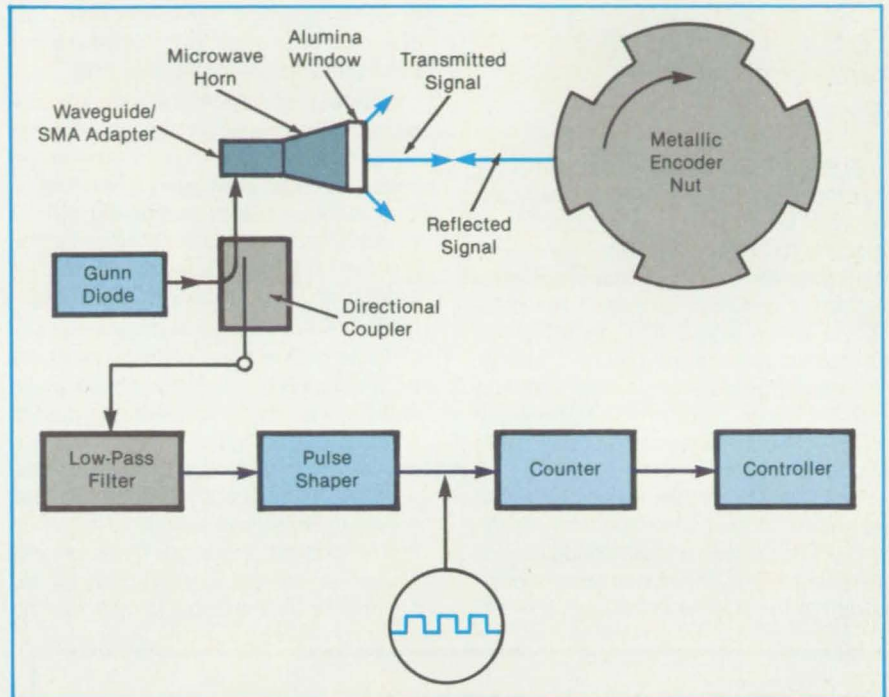

A Reflected Microwave Signal is amplitude-modulated by the passing reflective facets of a nut on the rotating shaft. The modulation frequency is measured to find the rotational speed.

cavitation.

This work was done by J. M. Maram and L. Wyett of Rockwell International

Corp. for Marshall Space Flight Center. No further documentation is available. MFS-28083

Books and Reports

These reports, studies, and handbooks are available from NASA as Technical Support Packages (TSP's) when a Request Card number is cited; otherwise they are available from the National Technical Information Service.

Simulating Single-Event Upsets in Bipolar RAM's

This simulation technique can save much testing.

A technical paper presents the results of computer simulations of single-event upsets in bipolar integrated circuits — particularly random-access memories (RAM's). NASA Tech Briefs, January/February 1986

A companion paper discusses experiments to check the accuracy of the simulation.

Although metal-oxide-semiconductor (MOS) integrated circuits have received more attention, bipolar chips are also susceptible to single-event upsets and will become even more so as they are made smaller. Also known as single-particle soft-error generation, this phenomenon is manifested as a bit flip in a flip-flop or a RAM cell. It occurs when an energetic heavy ion traverses a transistor or diode in a chip.

The simulation uses an interactive version of SPICE (Simulation Program with Integrated Circuit Emphasis). The device and subcircuit models available in the software are used to construct a macromodel for an integrated bipolar transistor. Time-dependent current generators are placed inside the transistor macromodel to simulate charge collection from an ion track.

In the experiments, a Van de Graaff accelerator was used to measure the single-

event upset cross section as a function of the kinetic energy of positively-charged bromine ions for both unaddressed and addressed cells loaded with either all ones or all zeros. For the addressed cells, most of the measured values agreed within experimental error with the values calculated in the computer simulation.

A significant finding of the experiments is that the standard design practice of reducing the power in an unaddressed bipolar RAM cell increases the sensitivity of the cell to single-event upsets. The reason for this is that a RAM cell operating in the unaddressed, standby mode responds more slowly and allows charge to collect over a longer time period. An unaddressed cell may respond to an ion track anywhere in the bipolar transistor through charge collection at all junctions.

This work was done by John A. Zoutendyk of Caltech for NASA's Jet Propulsion Laboratory. To obtain copies of the re-

ports, "Soft-Error Generation due to Heavy-Ion Tracks in Bipolar Microcircuits" and "Experimental Determination of Single-Event Upset (SEU) as a Function of Collected Charge in Bipolar Integrated Circuits," Circle 2 on the TSP Request Card. NPO-16491

Plasma Source for Charge Control

Electrical charges on a spacecraft would be neutralized.

A plasma source would neutralize the electrical charge on a spacecraft, according to a preliminary report. When triggered by a command from the spacecraft potential monitor or from the control system, the plasma apparatus would respond within about 1 s, generating a charged plasma of the required polarity. The discharging system is to be tested on the Air Force Geophysics Laboratory BERT-1 (Beam Emission Rocket Test) sounding rocket.

The source includes a rapidly-starting hollow cathode in a containment vessel, with a biasing keeper electrode to control the plasma flux. The working gas used to generate the plasma is fed from a reser-

voir to the source through a latching valve, pressure regulator, and flow-metering valve.

A lightweight power supply operating on 28-V input includes separate starting and running converters for rapid starting and the establishment of a stable plasma in the cathode barrel. The discharge current in the cathode is maintained at 2 A in all operating modes. The particle flux from the cathode is preset at 0, 0.3, 1.2, or 2.0 A by setting the keeper bias. This bias can be positive to collect electrons or negative to collect positive ions.

The plasma source is electrically connected to the spacecraft through a current-sensing resistor. A current-integrating circuit indicates the magnitude and polarity of the total charge leaving the plasma source: This measurement helps to quantify the degree of spacecraft charge buildup and the efficacy of the charge-neutralizing apparatus.

Three different sets of experiments will be conducted during the test flight. In the first set, the vehicle will be charged by an electron gun, ion gun, or capillaritron ion source, then discharged by the plasma source, all at various altitudes, plasma-source modes, and vehicle charges. In the second set, the ability of the plasma source to prevent charging will be examined by first turning on the plasma

source, then attempting to induce a charge with one of the artificial sources. In the third set, a plate will be biased at -500, -1,000, or 2,000 V to examine current collection from the plasma source at these biases.

This work was done by Graeme Aston, Lewis C. Pless, and William D. Deininger of Caltech for NASA's Jet Propulsion Laboratory. To obtain a copy of the report, "Plasma Source for Spacecraft Charge Control," Circle 95 on the TSP Request Card. NPO-16576

Single-Event Upsets Caused by High-Energy Protons

Heavy secondary ions do not significantly alter device responses.

Concern that nuclear reaction products generated by protons external to a digital integrated circuit might increase the number of single-event upsets in the circuit is unfounded, according to a report. The report is based on a study in which 10 types of digital integrated circuits were subjected to 590-MeV protons. The concern evolved from the possibility that heavy ions produced by protons striking an integrated circuit, the circuit lid, and even shielding near the circuit could lead to high rates of single-event upset.

The study was done to clarify the understanding of single-event upsets caused by high-energy protons like those found in galactic cosmic rays, solar flares, and belts of trapped radiation. It examined the relationship between single-event-upset cross sections and proton energy, the effect of nuclear reaction products from metal overlayers (including device lids), and the influence of the angle of incidence of the radiation. The devices tested included 1K random-access memories, 4-bit microprocessor bit-slices, 9-bit data registers, a 4-bit shift register, an octal flip-flop, and a 4-bit counter.

The conclusion that external reaction products cause no significant alteration of single-event-upset response was based on a comparison of data obtained from both lidded and unlidded devices and for proton beams impinging at angles ranging from 0° to 180° with respect to the chip face. The study also found that the single-event-upset cross section increases only modestly as proton energy is increased to 590 MeV, which is characteristic of the maximum energies expected in the belts of trapped protons surrounding Earth and Jupiter.



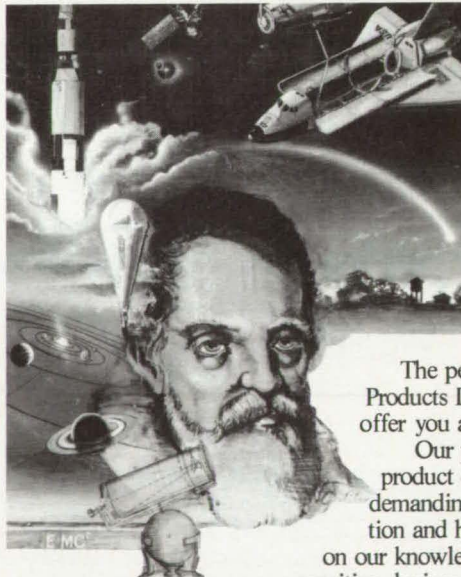

How will our experience benefit you?

The people of the ITT Electro-Optical Products Division, Fort Wayne operation, offer you a strong ally: **experience**.

Our people provide you with proven product development experience in such demanding applications as space exploration and high-tech research. You can rely on our knowledge for custom designed photosensitive devices to meet your particular needs.

From one device, to several thousand, you are provided with high-quality intensified solid-state-array cameras, image intensifiers, photomultipliers, image dissectors, photodiodes and accessories.

Ask for our catalog of Special Purpose Photosensitive devices. Put our proven experience to work for you.

Contact ITT Electro-Optical Products Division • P.O. Box 3700 • Fort Wayne, IN 46801 • (219) 423-4341 • TWX: 810-332-1413 • Telex: 232-429.

Free full-color poster of above illustration if requested on your letterhead.

ELECTRO-OPTICAL PRODUCTS DIVISION **ITT**

The devices most susceptible to protons were the same as those most susceptible to heavy ions. The correspondence is not exact, however; a proton can occasionally induce single-event upset in a relatively insensitive device when a nuclear reaction deposits an unusually large amount of energy.

This work was done by William E. Price, Donald K. Nichols, Lawrence S. Smith, and George A. Soli of Caltech for NASA's Jet Propulsion Laboratory. To obtain a copy of the report, "The Single Event Upset (SEU) Response to 590 MeV Protons," Circle 61 on the TSP Request Card.

NPO-16504

Hyperspectral Infrared Images of Terrain

Images at 128 wavelengths allow direct identification of many earth surface materials.

Two reports describe an advanced airborne spectrometer that creates images of terrain at many wavelengths. It can be used for agricultural, geological, and other surveys. The system was described previously in "Imaging Spectrometer for Geophysical Surveys" (NPO-16072) on page 76

of *NASA Tech Briefs*, Vol. 9, No. 1.

The airborne imaging spectrometer (AIS) produces two-dimensional images in 128 spectral bands in the 1.2-to-2.4-micrometer wavelength region. The images are created by a 32-by-32 array of mercury cadmium telluride detector elements. The array views a swath of Earth below the moving aircraft.

Light is collected by reflecting foreoptics and focused on a slit, which defines the width of the track on the ground. The combined foreoptics and spectrometer optics provide a focal length of 36 millimeters and a field of view of 1.9 milliradians per pixel. Light passing through the slit is dispersed by a grating in the spectrometer, then refocused on the detector array. Thus, an image line 32 pixels wide is repeated simultaneously at 32 wavelengths along the length of the array. The grating is stepped through four positions during each image-line period, producing lines at a total of 128 contiguous wavelengths.

The detector array is cooled by liquid nitrogen. The detectors are mated to a silicon charge-coupled device (CCD) multiplexer: This arrangement allows a relatively long integration time on the detectors, which can then be read out to the multiplexer quickly. While the signal is being read out from the multiplexer at a more leisurely rate, the detectors are integrating new signals.

The electronic equipment for the spectrometer is packaged in a two-bay, aircraft-compatible rack, 1½ meters high. The rack contains a control panel, analog and digital electronics, a programable word generator, clock drivers, power panel, oscilloscope, recording altimeter, and tape recorder. The AIS is controlled by commands entered from the control panel keypad.

The digital electronics, which provide the clock signals that control the detector array, consist of a single-board computer, a programable waveform generator, clock drivers, and interface electronics. The digital electronics also control the grating drive, the film camera, a calibration lamp, and the tape recorder. The analog electronics connect with the detector array through two parallel paths, each containing a voltage amplifier and a dual correlated sample-and-hold circuit.

This work was done by Gregg Vane, Alexander F. H. Goetz, John B. Wellman, and Clayton C. LaBaw of Caltech for NASA's Jet Propulsion Laboratory. To obtain a copy of the reports "Airborne Imaging Spectrometer: A New Tool for Remote Sensing" and "Experiments in Infrared Multispectral Mapping of Earth Resources," Circle 30 on the TSP Request Card. NPO-16295



"SD-Ada™ for MIL-STD-1750 is Available Now. Any Questions?"

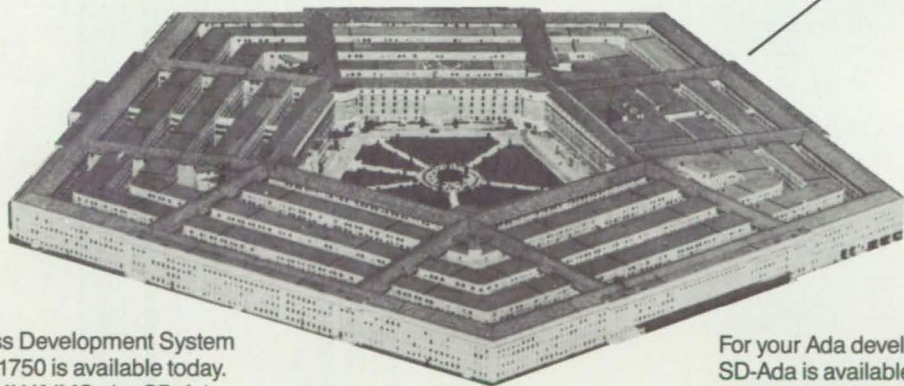

SD-Ada Cross Development System for MIL-STD-1750 is available today. Running on VAX/VMS, the SD-Ada host compiler upon which the cross development system is based is DoD validated, and implements the full ANSI/MIL-STD-1815A language standard as well as uses the DoD-approved DIANA Ada intermediate language.

For users of the Motorola 68000, SD-Ada provides comprehensive facilities for the cross development

of systems for a whole range of 16/32-bit microprocessors.

Systems Designers is one of the leading pioneers in the development of Ada systems, and our products are the result of hands-on knowledge and experience. In fact, we have contributed much to the international Ada effort, starting at the inception of the project.

For your Ada development needs, SD-Ada is available and validated. All you have to do is call (617) 935-8009 Extension 25, or write today, and we'll be glad to answer any of your questions. Thank you.



Systems Designers Software Inc.

444 Washington Street, Suite 407
Woburn, MA 01801 Telephone: 617-935-8009
Telex: 5101002943 Telecopier: 617-935-3070

Ada is a trademark of the U.S. Government Ada Joint Program Office

Circle Reader Action No. 303

Physical Sciences

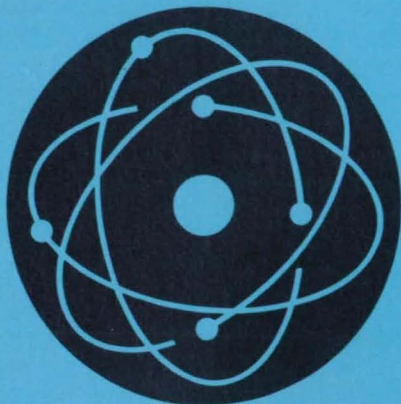

Hardware, Techniques, and Processes

- 70 Seebeck Coefficient Measured With Differential Heat Pulses
- 72 Brewster-Plate Spoiler for Laser Spectrometer
- 75 Test Method for X-Ray Telescopes

Books & Reports

- 77 Microwave Power From Natural Emitters

Computer Programs

- 78 Deformable Subreflector Computed by Geometric Optics
- 78 Computing Composition/Depth Profiles From X-Ray Diffraction
- 79 Thermodynamic Calculations for Complex Chemical Mixtures

Seebeck Coefficient Measured With Differential Heat Pulses

Common experimental errors are reduced because the pulse technique suppresses drifts in thermoelectric measurements.

NASA's Jet Propulsion Laboratory, Pasadena, California

A differential-heat-pulse apparatus measures the Seebeck coefficient in semi-conductors at temperatures up to 1,900 K. The output is a plot of the Seebeck voltage versus the temperature difference, the slope of which is the Seebeck coefficient. Because a pulse technique is used, the errors that often arise from long-term drifts in thermoelectric measurements are suppressed. The apparatus works with temperature differences of only a few degrees, thereby further increasing the accuracy of the coefficients so obtained.

The sample is placed in a furnace (see Figure 1) in a vacuum. The Nb wires of

Nb/W thermocouples make contact with the upper and lower ends of the sample. Sapphire light pipes conduct infrared radiation from two light bulbs to the opposite ends of the sample.

Initially, the furnace is brought to the measuring temperature. A small current is applied to each light bulb, thereby generating infrared radiation that heat both ends of the sample by the same small amount (of the order of a degree). Then, for the Seebeck measurements, the current of one lamp is increased while the current of the other lamp is decreased by approximately the same amount: The exact amounts are

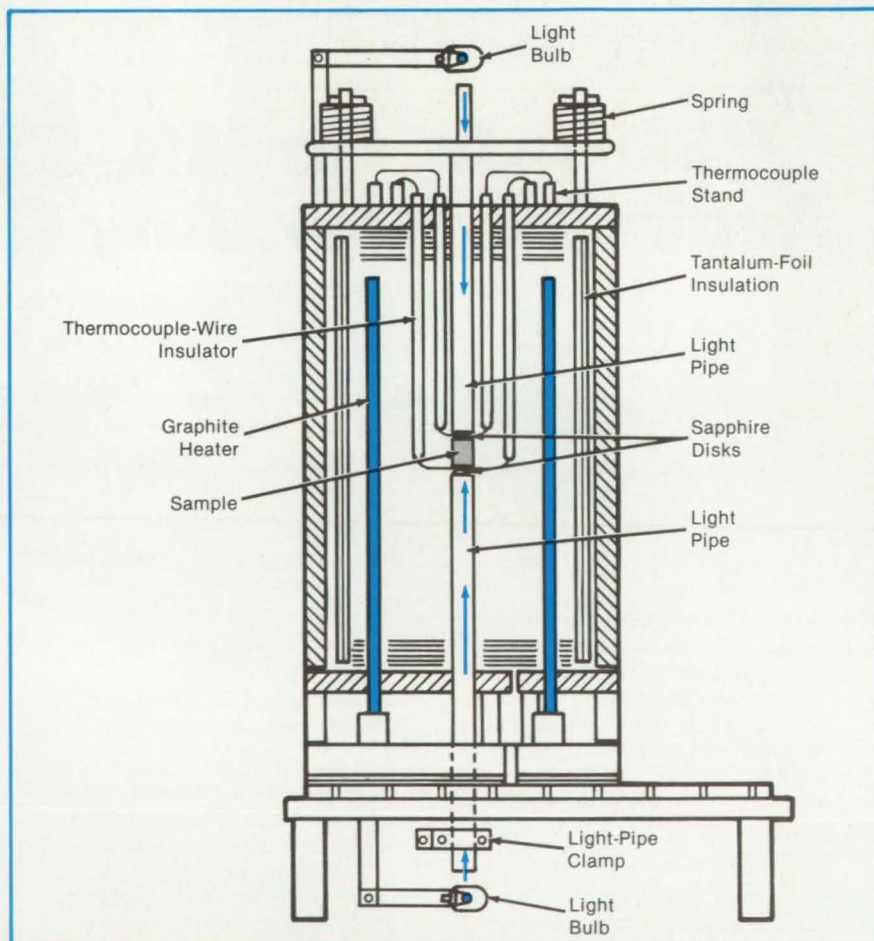
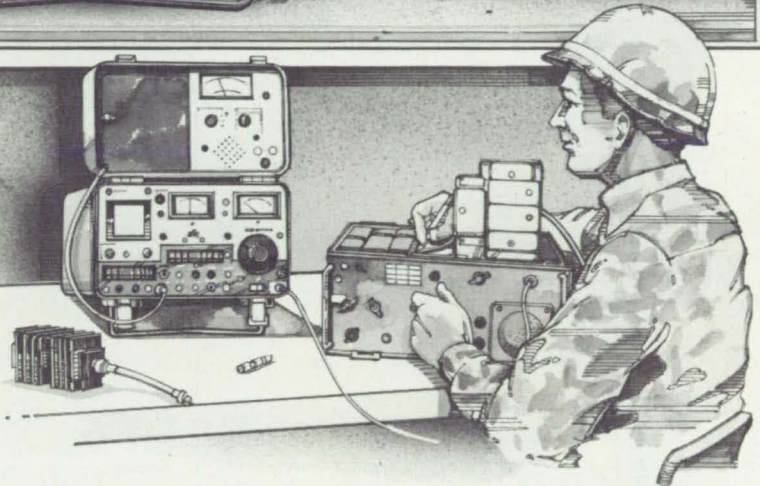
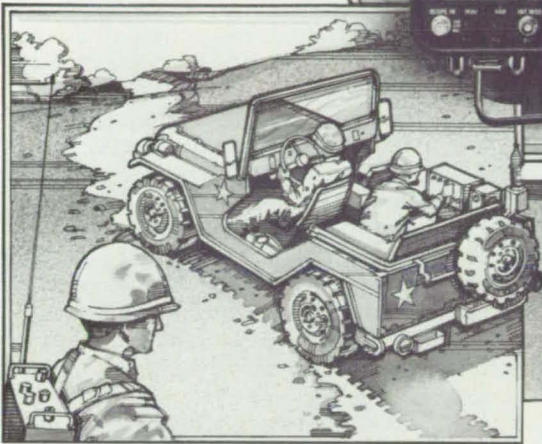
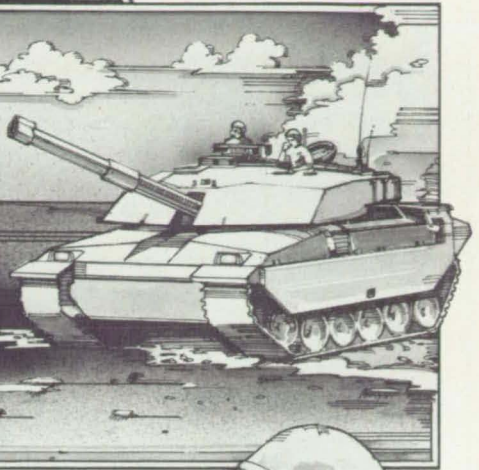
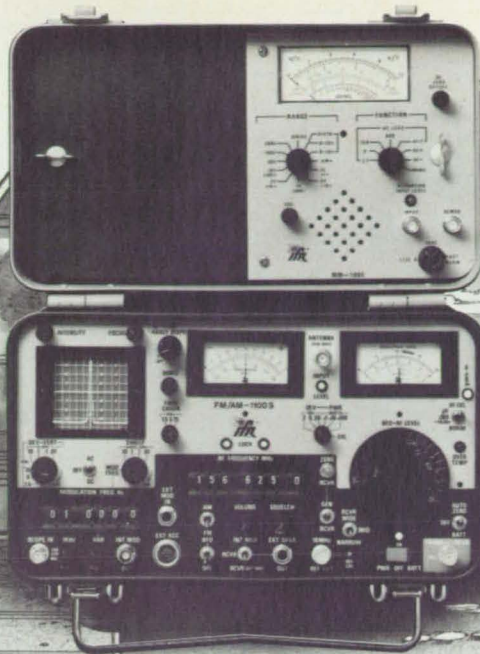

Figure 1. A **Sample Is Heated** to a measuring temperature in this furnace. The ends of the sample are then differentially heated a few degrees more by lamps. The differential temperature rise and the consequent Seebeck voltage are measured via the thermocouple leads.

**Six Years Field
Tested by US Army!
Proven! Ready!**



**AVAILABLE FOR
IMMEDIATE SHIPMENT!**

AN/GRM-114A*

IFR Provides the Operational Support You Need!

- Complete training courses and materials — Audio Visual and Technical Manuals — available for both operation and maintenance.
- Maintenance and logistic support exists and available to US Army from manufacturer.
- Established radio maintenance procedures. VRC-12 maintenance manual updated for test with IFR AN/GRM-114A.
- Human-engineered for operational simplicity.
- IFR has state-of-the-art technical expertise with test equipment and radio communications.

**AN/GRM-114A Available Immediately to
the Armed Forces through GSA —**

■ **GS-OOF-70448**

For more information contact IFR, Inc., 10200 West York Street, Wichita, Kansas 67215, 316/522-4981

FSN: 6625-01-144-4481

Manufacturers of
Communications,
Avionics Test Equipment
and ATE Systems



*the
best is
cost
effective*

TWX 910-741-6952

A Subsidiary of **Regency** ELECTRONICS, INC.

*** Necessary to Support VINSON...TACFIRE
and all AM/FM SSB Radio Maintenance**

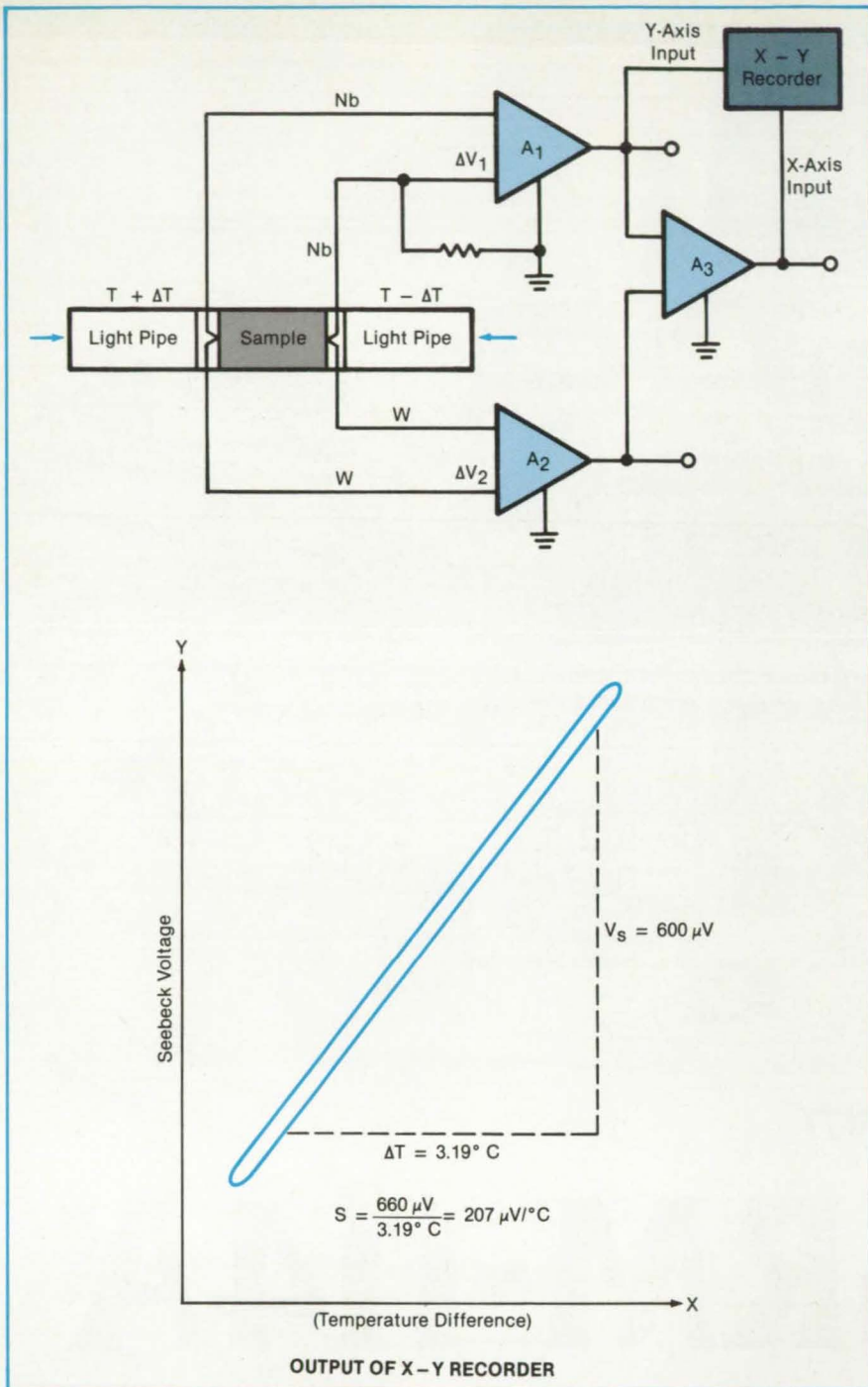

chosen so that the temperature rise at one end increases while the temperature rise at the other end decreases, but the average temperature rise of the sample remains the same as in the initial setting.

As shown in Figure 2, the thermocouple leads are used to measure both the temperature difference between the sample ends and the Seebeck voltage, which is the voltage between the sample ends that arises by virtue of the temperature difference. Since Nb is known from previous measurements to have a negligible Seebeck voltage, the voltage between the Nb thermocouple leads can be assumed equal to the Seebeck voltage of the sample for practical purposes. This signal is fed to amplifier A₁, the output of which drives the Y-axis motion of an X-Y recorder.

The difference between the voltage on the Nb wire pair (ΔV_1) and the voltage on the W wire pair (ΔV_2) is essentially the difference between the thermocouple outputs and therefore is proportional to the temperature difference between the ends of the sample. The output of amplifier A₃ is proportional to $\Delta V_1 - \Delta V_2$ and is fed to the X input of the X-Y recorder for display as the temperature difference. Thus, as a differential heat pulse causes a shift along the differential-temperature (X) axis, it also causes a shift along the Seebeck-voltage (Y) axis, yielding a direct plot of the Seebeck effect in the sample.

This work was done by Leslie Zoltan, Charles Wood, and Gerhard Stapfer of Caltech for NASA's Jet Propulsion Laboratory. For further information, Circle 13 on the TSP Request Card. NPO-16506

Figure 2. The **Seebeck and Differential Thermocouple Voltages** are separated from each other by subtraction in amplifier A₃. These voltages are then fed to an X-Y recorder. The recording shown here was taken on a sample of B₁₃C₂ at 450°C. The hysteresis in the plot is probably an inherent measurement error due to temperature differences between the sample and the thermocouples.

Brewster-Plate Spoiler for Laser Spectrometer

Unwanted interference effects are reduced.

NASA's Jet Propulsion Laboratory, Pasadena, California

An oscillating Brewster plate reduces the effects of unwanted interference fringes on absorption-spectroscopic measurements obtained with tuned diode lasers. The fringes arise from reflections

of laser beams at the surfaces of windows, lenses, and other optical elements. These fringes become superimposed on the absorption spectra and are particularly troublesome during measurements of molecular

absorptions smaller than 0.01 percent.

The oscillating plate, or spoiler, is mounted in the laser-beam path between the surfaces that cause the fringes (see figure). It is oriented at the Brewster angle

ACOUSTO-OPTIC TECHNOLOGY from...

RELIABLE DESIGN AND
PROVEN QUALITY IN
COMPONENTS AND SYSTEMS

 **IntraAction Corp.**

FEATURES such as high optical power capability, temperature stability, high speed scanning with high diffraction efficiency employing acoustic phased array beam steering, polarization integrity, low cost, and simplicity of operation provide solutions for your system modulation and deflection design requirements. IntraAction's experienced staff is ready to work with you on your system designs and OEM requirements.

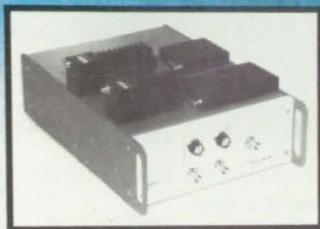

MODULATORS

MODEL	WAVELENGTH	EFFICIENCY %	MOD. BW MHz @ mm	RISE TIME nsec	ACTIVE APERTURE	BEAM SEPARATION	DRIVE ELECTRONICS
AOM-70U	300-400 nm	80	30 @ .14	16	1 mm	4.27 mr	ME-70
AOM-125B	442 nm	80	30 @ .1	16	.6 mm	14.3 mr	MOP-125
AOM-40	440-700 nm	90	4.5 @ .65	110	2 mm	6.5 mr	ME-40
AOM-80	440-700 nm	80	15 @ .18	35	1 mm	13.9 mr	ME-80
AOM-110	440-700 nm	70	20 @ .14	24	.6 mm	19.2 mr	ME-110
AOM-125	440-700 nm	70	20 @ .14	22	.6 mm	20.5 mr	ME-125
AOM-40R	1.06 um	80	2.9 @ 1	170	2 mm	10.8 mr	ME-40R
AGM-406B	10.6 um	80	.68 @ 6	700	6 mm	77 mr	GE-4040

INTRA-CAVITY MODULATORS

MODEL	WAVELENGTH	TYPE	EFFICIENCY % @ WATTS	CENTER FREQ.	FEATURES	DRIVE ELECTRONICS
AQS-244A	1.06 um	Q-SWITCH	40 @ 10	24 MHz	HIGH EFFICIENCY	QE-2425
AQS-244B	1.06 um	Q-SWITCH	40 @ 40	24 MHz	POL. INSENSITIVE	QE-2450
AQS-244C	4-1.3 um	Q-SWITCH	40 @ 10	24 MHz	BREWSTER WINDOW	QE-2425
AQS-247B	1.06 um	Q-SWITCH	40 @ 65	24 MHz	LARGE APERTURE	QE-2475
AQS-504A	1.06 um	Q-SWITCH	40 @ 15	50 MHz	HIGH EFFICIENCY	QE-5025
ML-50Q	1.06 um	MODE LOCKER	50 @ 5	50 MHz*	BREWSTER WINDOW	MLE-6A
ML-70B	1.06 um	MODE LOCKER	50 @ 5	70 MHz*	2° RHOMBOID	MLE-*

*USER SPECIFIED FREQUENCIES AVAILABLE

DEFLECTORS

MODEL	TIME B W spots	ACCESS TIME u sec.	EFFICIENCY %	BANDWIDTH	APERTURE	SCAN RATE	DRIVER (MOD. OPT.)
ADM-40	100	5	85	20 MHz	2 x 20 mm	40 KHz	DE-40 (M)
ADM-70	200	5	80	40 MHz	2 x 20 mm	40 KHz	DE-70 (M)
AOD-70	400	10	80	40 MHz	2 x 40 mm	20 KHz	DE-70 (M)
ADM-150	500	5	60	100 MHz	1.3 x 20 mm	40 KHz	DE-150 (M)
AOD-150	1000	10	60	100 MHz	1.3 x 40 mm	20 KHz	DE-150 (M)
AOD-150B	1000	10	70	100 MHz	1.3 x 40 mm	20 KHz	DE-150 (M)

Circle Reader Action No. 428

 **IntraAction Corp.**
QUALITY PRODUCTS FOR LASER TECHNOLOGY

3719 WARREN AVENUE
BELLWOOD, IL 60104
(312) 547-6644 TELEX 270504

American Business Leaders Who Do Not Join The War On Government Waste And Fight The Deficit – Are Shooting Themselves And Our Country In The Foot!



Here's Why

Despite "promising" economic forecasts and the public's patient "wait and see" attitude, the deficit is at record levels. So is wasteful and inefficient spending in government.

Many executives are openly decrying the deficit as the one thing that can derail the economy in 1985 and beyond. Among the consequences:

- A collision between the private sector and the U.S. Treasury for access to the credit markets.
- Reduced worth of personal and corporate portfolios.
- Increased taxes that will slash growth and inspire layoffs.
- The transfer of a bigger deficit and unwieldy debt to the next generation.

Business leaders need to get the attention of those politicians and bureaucrats who are dragging their feet in cutting waste and inefficiency in government.

Fortunately, the hard work is already done

The ground work has been laid by the Grace Commission Report, which details 2,478 ways to reduce federal waste, inefficiency and overspending. Once adopted these proposals would save \$424.4 billion over three years, and effectively get America out of hock.

The report provides solid evidence that government waste and inefficiency can be reduced. It provides practical ways to cut waste without weakening our national defense and eliminating necessary subsidy programs.

What you can do as a business leader

We need your help to distribute the Citizens Against Waste Petition to be served on the 99th Congress, to let the lawmakers know there's some real pressure building among their constituents to cut the deficit and stop waste.

Sponsor a petition center that includes a 24" x 37" Poster for display and the 500-petition display (a 10,000-name potential).

The cost is only \$40.00 delivered prepaid.

The display takes up less than one square foot of space and is an investment that is sound business practice for all concerned.

The deficit is the one economic culprit that can singlehandedly derail the economy, slash growth, inspire layoffs and reduce the worth of personal and business finances – not only for 1985, but for years to come.

It is essential that more and more Americans pool their efforts and their money to establish a vocal and powerful group to pressure those politicians and bureaucrats who insist on wasting tax dollars and using government funds for their own pet projects,

Not to mention, the urgent need for all public officials to become more accountable, answerable, and responsive to the American taxpayer.

Pressure works! Politicians do and will respond if the numbers of petitions are big enough.

In fact, they'll buckle under. It's been proven in the past that pressure works. From the Child Labor Law, the Women's Right To Vote, Workmen's Compensation, the Civil Rights Act, and the recent and very successful efforts to curb drunk driving by SADD and MADD, we have seen that Congress WILL respond time and again. But only when they're convinced that the people are serious.

Citizens Against Waste – Who We Are

Citizens Against Waste is a nonprofit foundation of bipartisan and concerned citizens from all walks of life, who've come together to "educate" the Federal bureaucratic spenders and waste makers in Congress about the absolute necessity to curb overspending, waste and inefficiency to eliminate the deficit.

Citizens Against Waste

1511 K Street NW,
Washington, D.C. 20005
ATTN: J. P. Bolduc, President

Dear Mr. Bolduc:

Here is my order for _____
petition centers @ \$40.00 each.

Check enclosed for \$ _____

Name _____

Title _____

Company _____

Address _____

City _____

State _____ Zip _____

Enclose a PR kit on how we can spread the word that the petition centers are available in our business.

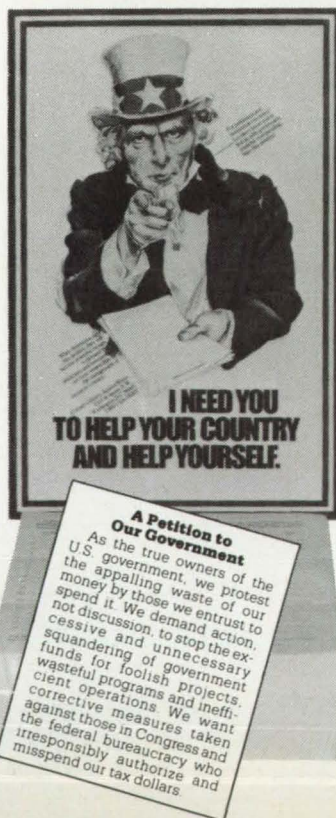

For more information,
call 1-800-USA-DEBT.

(the angle at which the beam component polarized in the plane of incidence is not reflected from the first surface) to minimize reflection losses when polarized laser beams are used. The plate is oscillated about the Brewster angle with an amplitude up to a few degrees: This varies the optical path length, thereby changing the resonant frequency of the optical cavity defined by the fringe-producing surfaces and altering the fringe pattern. The rapid oscillation blurs the fringes; that is, the time-averaged fringe effect is reduced.

The plate material must be substantially transparent at the laser wavelength. The plate must not be so thick that it introduces excessive beam aberrations or is too massive to oscillate conveniently, but must be thick enough so that it will not break and so that, at the chosen oscillation amplitude, the cavity length is scanned past several resonance peaks.

The plate may be driven by a galvanometer, for example. A waveform generator drives the galvanometer. The best oscillation waveform for fringe averaging is usually a triangular wave because, unlike others (for example, a sinusoid or a square wave), it does not cause the plate to dwell for a substantial portion of the time at or near the turning points.

The oscillation causes some unwanted amplitude modulation of the laser beam. Consequently, the oscillation frequency must be high enough to cause an averaging of the fringe pattern in an interval less

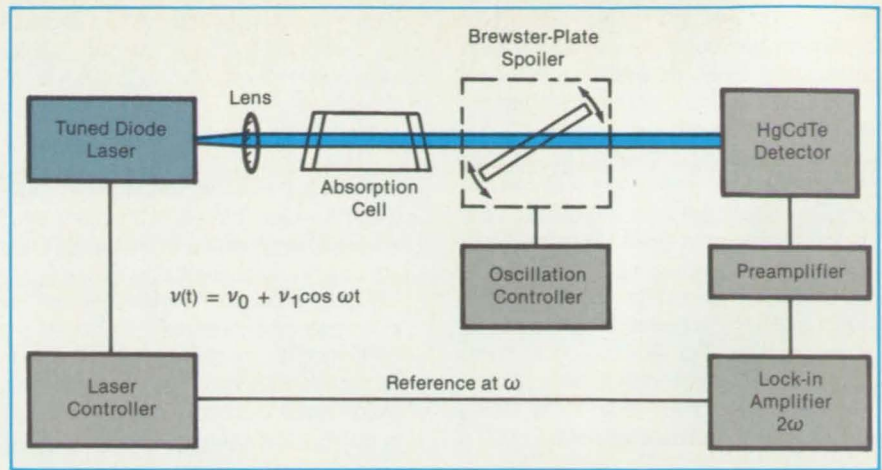

The **Oscillating Brewster Plate** modulates the optical-path length past several resonance peaks causing interference fringes to pass by rapidly and become blurred. Thus, the fringe effects are averaged out over time.

than the time to scan the tunable laser over half the fringe period. The frequency must also lie outside the passband of the lock-in amplifier.

A Brewster-plate spoiler was demonstrated successfully in absorption measurements on N_2O : Weak absorption lines that were masked by interference fringes could be distinguished when the spoiler was turned on. For tunable-diode laser spectroscopy in the midinfrared region, the spoiler technique is expected to enable the detection of absorptances less than 10^{-5} in single laser scans. The technique can also be used at other wavelengths from ultraviolet to infrared and in

spectrometers with short or long optical paths, including those with retroreflectors or multipass cells.

This work was done by Christopher R. Webster of Caltech for NASA's Jet Propulsion Laboratory. For further information, Circle 87 on the TSP Request Card.

This invention is owned by NASA, and a patent application has been filed. Inquiries concerning nonexclusive license for its commercial development should be addressed to the Patent Counsel, NASA Resident Office-JPL [see page 21]. Refer to NPO-16567.

Test Method for X-Ray Telescopes

Ring images reveal surface deviations.

Marshall Space Flight Center, Alabama

Telescopes in general, and X-ray telescopes in particular, could be tested with nearby point sources of radiation. When

point-source rays enter a telescope through an annular entrance pupil (and under conditions of spherical aberration),

a ring image is produced. The deviation of this ring image from a perfect circular shape reveals misalignments and sur-

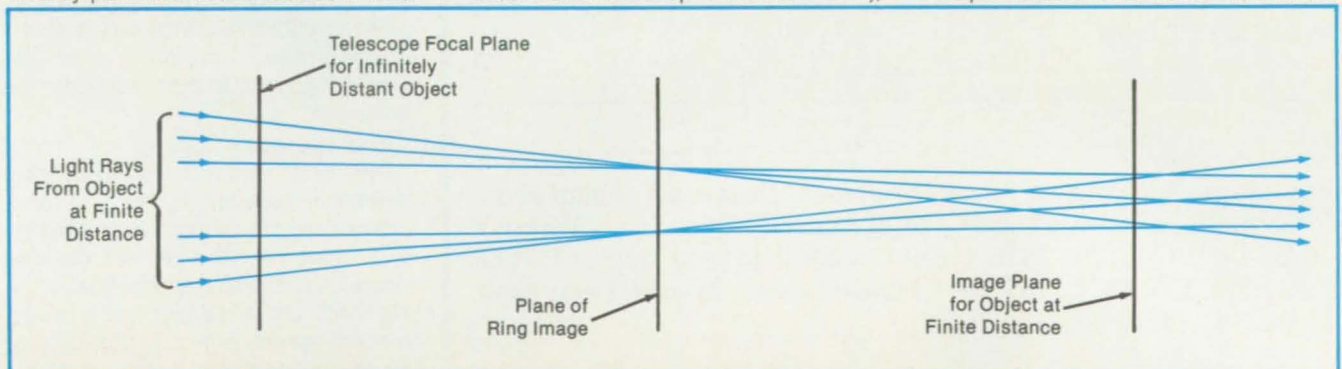

Figure 1. A **Ring Image Is Formed** by a telescope when a point light source is placed on the telescope optical axis at a finite distance.

face inaccuracies in the telescope. Although particularly suited for grazing-incidence types of systems, this test method can be applied to other types of optical systems as well.

Because of the difficulty of producing a large-diameter, collimated X-ray beam, an X-ray telescope is usually tested with a point source at a finite distance. However, because telescopes are optimized for maximum resolution of infinitely distant targets, this resolution decreases for closer targets. For example, if an astronomical X-ray telescope assembly were tested conventionally in an X-ray facility [at an object distance of about 1,000 ft

(305 m)], the resolution would decrease by a factor of 5 to 6, making the test results imprecise. An extension of the X-ray facility would increase the precision but would be very expensive.

These problems could be avoided in the new test method, which would exploit the ring image formed by an imaging system with an annular entrance pupil under conditions of spherical aberration. Spherical aberration can always be introduced in an imaging system with a point source positioned on the optical axis, away from its design distance. In the case of a telescope, spherical aberration is introduced by using a finite object distance (see Fig-

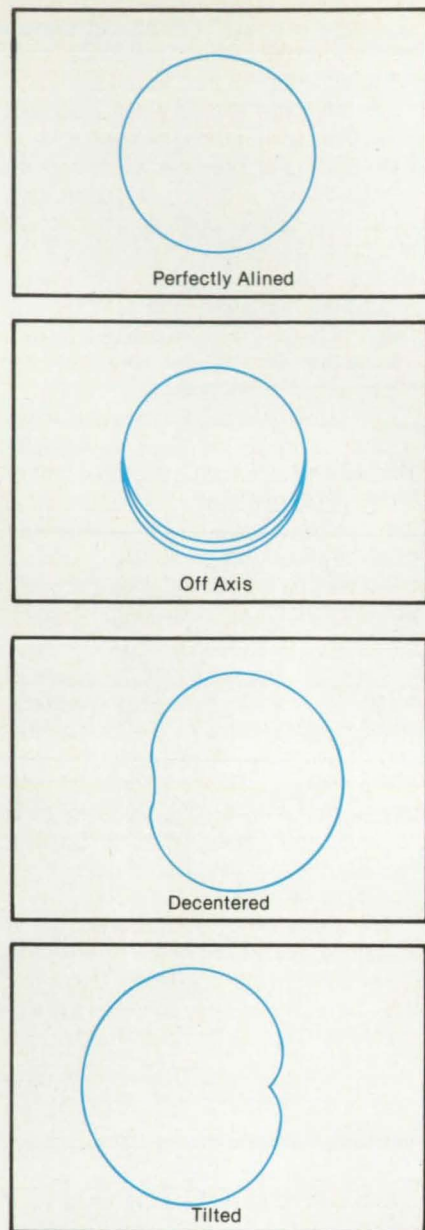

Figure 2. **Misalignments and Surface Irregularities** in telescope systems can be identified from the ring images produced when rays from a nearby point source enter through an annular pupil. The rings shown here resulted from a two-mirror grazing-incidence X-ray telescope with various misalignments.

ure 1). The very sharp ring image is located a particular distance away from the blurred image of the point object, depending upon the amount and sign of the aberration.

Because each point of the ring is formed by all rays in the corresponding meridional section, any surface inaccuracy along this section causes the ring to deviate from the perfect circular shape. Characteristic deformations of the ring image also reveal aberrations caused by misalignment. Examples of such ring-image deformations for a two-mirror grazing-incidence telescope are shown in Figure 2. In the case of nested, grazing-

NASA Tech Briefs, January/February 1986

SPACE THE NEW FRONTIER

The Equity Research Department of
Shearson Lehman Bros., Inc.

and

The Center for Space Policy, Inc.
advisors to the U.S. Government and Industry
are pleased to announce

SPACE

the first monthly analysis of commercial
investment opportunities in space.

The financial expertise of SHEARSON LEHMAN BROS., INC. and the special knowledge of THE CENTER FOR SPACE POLICY have teamed to offer a totally new investment service, to help investors evaluate these and other opportunities in this New Frontier.

For information contact: James P. Samuels, Shearson Lehman Bros., Inc., American Express Tower, World Financial Center, New York, NY 10285-1400, (212) 298-3518 or Brad M. Meslin/David Lippy, CENTER FOR SPACE POLICY, INC. 1972 Massachusetts Avenue, Cambridge, MA 02140, (617) 576-2266/2828.

Circle Reader Action No. 384

incidence telescope systems, each subsystem forms its own ring image, and the concentricity of these images is a further

indication of the state of alignment.

This work was done by Dietrich Korsch of Korsch Optics, Inc., for Marshall

Space Flight Center. No further documentation is available. MFS-26020

Books and Reports

These reports, studies, and handbooks are available from NASA as Technical Support Packages (TSP's) when a Request Card number is cited; otherwise they are available from the National Technical Information Service.

Microwave Power From Natural Emitters

The signal-to-noise ratio of a radiometer system is calculated.

A publication from NASA's Jet Propulsion Laboratory presents calculations of the power radiated from a natural emitter on the Earth to a microwave collecting aperture on an aircraft or a spacecraft. The analysis develops the power-transfer criteria for the detection of the emitting object by the collecting aperture (that is, by the antenna and its receiver). The resulting formulas can be used in the design of radiometer systems.

To simplify the analysis, the object is treated as a diffusely-reflecting and diffusely-radiating Lambertian disk emitter on the surface of the Earth, oriented perpendicularly to the Earth's radius. The object is taken to be sufficiently small and the antenna sufficiently high (or both) so that the object can be treated as a point source from the perspective of the receiver.

The total noise in the receiver output is characterized by the orthogonal sum of the clutter-noise temperature and the temperature of the noise generated within the receiver. Clutter noise has several components, including power received along the antenna side lobes from the background or from objects other than the one in view and statistical variations in the component of background radiation that comes in with the object radiation along the main lobe. Clutter irradiances arise especially while scanning across thermal discontinuities like those among forests, bare land, ice, and water. Typically, the clutter power exceeds the rms noise power of the receiver.

The power density arriving at the receiver location from the object is calculated from the object size, emissivity, temperature, distance from the receiver, and direction, using the expressions for Lambertian gray-body radiation. The portion of this power intercepted by the antenna is calculated in terms of the antenna aperture

NASA Tech Briefs, January/February 1986

size and the combined collecting efficiency of the aperture and the feed structure for radiation arriving within the main lobe.

An expression is then derived for the signal-to-noise ratio in terms of the foregoing parameters, the receiver bandwidth, and the atmospheric attenuation along the path from the object to the antenna. Since the expression is in closed

form, it can also be rearranged to show, for example, the object size or antenna aperture size needed to detect the object with a specified signal-to-noise ratio.

This work was done by Joseph M. Stacey of Caltech for NASA's Jet Propulsion Laboratory. To obtain a copy of the publication, Circle 58 on the TSP Request Card. NPO-16581

"IMPRISONED"

by design limitations of your current

GHz BRAGG CELL?



BREAK
OUT...

...with
brimrose

ACOUSTO-OPTIC MODULATORS at their finest!

APPLICATIONS:

- GHz OPTICAL MODULATORS
- LASER CAVITY DAMPERS
- BROADBAND LASER DEFLECTORS
- LASER BEAM STEERING
- RADIO ASTRONOMY
- VARIABLE RANGE SIMULATORS
- OPTICAL COMPUTING
- RF SPECTROMETER
- FIBER OPTIC COMMUNICATIONS
- LASER DISK MODULATORS
- EW SYSTEMS
- FREQUENCY IDENTIFICATION

FEATURES:

- 90% RF WATT EFFICIENCY AT 1 GHz
 - CELLS FROM 25 MHz to 3 GHz
 - BANDWIDTHS TO 1 GHz
 - FULL RANGE OF AO MATERIALS
 - 2-D LASER DEFLECTORS
 - 6° DEFLECTION ANGLES
 - LARGE SCALE PRODUCTION CAPABILITIES
 - 96% YIELDS
 - ENGINEERING DESIGN
 - PERFORM GOVERNMENT CONTRACTUAL WORK
 - CUSTOM FABRICATION
- 30 DAY DELIVERY ON SELECTED ITEMS

AND MORE!

compare our devices with the best of them: HARRIS, ITEK, CRYSTAL-TECH, and TELEDYNE.

brimrose bragg cells: Worth "bragging" about.

for information
call or write:

brimrose corporation of america
7720 belair road
baltimore, maryland 21236
(301) 668-5800
telex 910-997-6817 brimrosecorp

Circle Reader Action No. 415

NEW CAPABILITIES FOR FIBER OPTIC TESTING

Not since Laser Precision introduced the world's first totally integrated OTDR, the TD-9901 in 1979, has there been an instrument like the TD-9950, all wavelength OTDR, to revolutionize the industry.

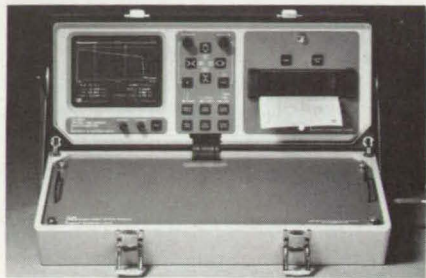

The TD-9950's unique HELP BUTTON provides instant display of operating instructions or on-line application notes. It can be used at any time, for a quick reference, without interfering with work in process. The

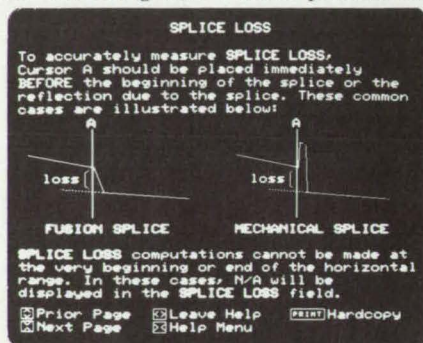

user can select either from the Help Menu or any function key to obtain clear operation instructions.

OPERATES AT ALL WAVELENGTHS

Designed for all wavelengths, the TD-9950 offers plug-in 850, 1300, 1550, and dual wavelength 1300/1550nm modules.

Specifications include: $\pm 0.01\%$ base-accuracy, 0.01dB resolution, 20dB minimum one-way backscatter range, 131 km range, one-meter resolution, dual cursors, and real-time display.

The TD-9950's built-in digital X-Y plotter provides complete data hardcopies for cable system documentation.

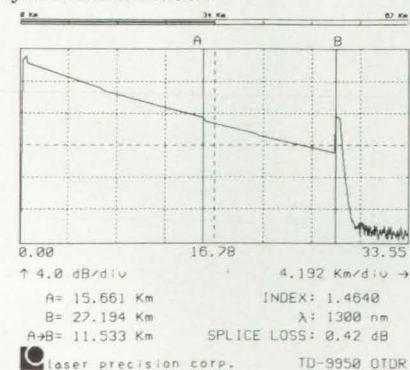

The automatic splice loss mode provides instant splice loss measurement, to within 0.01dB, on closely spaced or long distance splices. During splicing or connectorization, the real-time trace and continuous dB read-out enable the user to optimize the fiber core alignment.

For more information, contact Laser Precision Corporation, 1231 Hart St., Utica, NY 13502, or call (315) 797-4449.

Computer Programs

These programs may be obtained at a very reasonable cost from COSMIC, a facility sponsored by NASA to make raw programs available to the public. For information on program price, size, and availability, circle the reference number on the TSP and COSMIC Request Card in this issue.

Deformable Subreflector Computed by Geometric Optics

Distorted antenna surfaces are forced to produce a uniform wave front.

SUBFORMING employs geometric optics in determining subreflector coordinates to match a main reflector surface with known distortions. An antenna with a distorted paraboloidal reflecting surface can be forced to produce a uniform wave front by using a Cassegrainian geometry with a path-length-compensating subreflector.

First, the computed distortion vectors of the main reflector are best fitted to a paraboloid. Second, the resulting residual distortion errors are used to determine a compensating subreflector surface by ray tracing, using geometric optics. The solution is a set of points defining the subreflector contour. The slope of the surface and the normal to the surface are determined for each point.

This program is written in FORTRAN V for batch execution and has been implemented on a UNIVAC 1100-series computer with a memory requirement of approximately 25K of 36-bit words. The SUBFORMING program was developed in 1983.

This program was written by William F. Williams of Caltech for NASA's Jet Propulsion Laboratory. For further information, Circle 18 on the TSP Request Card. NPO-16405

Computing Composition/Depth Profiles From X-Ray Diffraction

Diffraction-intensity bands are deconvolved relatively quickly.

TIBAC constructs composition/depth profiles from X-ray diffraction-intensity bands. The intensity band is extremely

sensitive to the shape of the composition/depth profile. Numerical interpretation of a band has previously been achieved with trial-and-error matching of known profiles or with prohibitively-expensive computational simulation techniques. TIBAC incorporates a straightforward transformation of the intensity band that retains the accuracy of earlier simulation models, but is several orders of magnitude faster in total computational time.

TIBAC has the following options: Use a deconvolution routine to handle intensity broadening; transform the intensity band into a composition/depth profile; and determine the constant diffusion coefficient for a semi-infinite material. TIBAC will accept monochromatic or doublet X-ray data and will allow for various diffraction geometries, including overlayers and finite films.

The transformation of an intensity band into a composition/depth profile requires that relationships between the composition, d-spacing, linear absorption, and reflectivity be known. These data can be obtained from values in the literature or by outside calculations. The TIBAC output data are in tabular and plotted form, with the final graphs showing the calculated composition (in atomic percent) versus depth (in centimeters), along with the confidence limits and the observed composition/depth profile.

TIBAC is written in FORTRAN 77 for batch execution and has been implemented on a CDC CYBER 170-series computer with a central-memory requirement of 132K (octal) of 60-bit words. TIBAC has also been implemented on an IBM 370-series computer with a central-memory requirement of 267K of 8-bit bytes. For graphic output, the user must supply basic plot routines. TIBAC was developed in 1984.

This program was written by K. E. Wiedemann and J. Unnam of Analytical Services and Materials, Inc., for Langley Research Center. For further information, Circle 78 on the TSP Request Card. LAR-13356

Thermodynamic Calculations for Complex Chemical Mixtures

A computer program calculates equilibrium compositions and the corresponding thermodynamic and transport properties of these mixtures.

Many processes in existence today involve complex chemical mixtures, frequently at high temperatures. Some of these mixtures result from combustion processes such as those that occur in automobiles, aircraft, and rockets. Others occur in processing equipment in the chemical, petroleum, and natural-gas industries. Research equipment, such as shock tubes, also involves high-temperature gas mixtures. To understand better the nature of these processes, it is necessary to obtain equilibrium compositions and corresponding thermodynamic and transport properties of such complex chemical systems.

A general computer program, CECTRP, has been developed for the calculation of the thermodynamic properties of complex mixtures with an option to calculate transport properties of these mixtures. A free-energy minimization technique is used in the equilibrium calculation. Rigorous equations are used in the transport calculations.

This program has the capability of performing calculations such as (1) chemical equilibrium for assigned thermodynamic states, (2) theoretical rocket performance for both equilibrium and frozen composition during expansion, (3) incident and reflected shock properties, and (4) Chapman-Jonquet detonation properties. Condensed species, as well as gaseous species, are considered in the transport-property calculations.

The thermodynamic properties that are tabulated include pressure, temperature, density, enthalpy, entropy, Gibbs free energy, molecular weight, $(\partial \ln V/\partial \ln P)_T$, $(\partial \ln V/\partial \ln T)_P$, specific heat at constant pressure, isentropic exponent, sonic velocity, and composition. The calculated transport properties are viscosity and thermal conductivity. Specific heat and thermal conductivity are calculated for both frozen and equilibrium conditions. Prandtl and Lewis numbers are included. Other properties that are characteristic of this type of problem are also calculated.

A library of thermodynamic data in the form of least squares coefficients is provided for over 1,000 ideal gases and condensed species in the temperature range of 300 to 5,000 K. Transport and relaxation data are provided for 59 species, and additional transport data are provided for interactions between unlike species for another 58 interactions. When transport data are missing for a particular interaction, the data are estimated. The estimating techniques are built into the program.

CECTRP can accommodate up to 24 reactants, 20 elements, and 600 products, 400 of which may be condensed. It is written in FORTRAN IV for any large computer system: it is run at NASA Lewis Research Center on an IBM 370 and on a CRAY IS computer. The thermodynamic and transport data are used in an unformatted form. Many DO-loops have been vectorized for class VI computers.

This program was written by Bonnie J. McBride of Lewis Research Center. For further information, Circle 92 on the TSP Request Card.
LEW-14166

MICROSECOND RESPONSE THERMOCOUPLES

For surface temperature applications, such as:

- Internal Surface Temperatures • Pressure Vessels • Re-entry Heat Shields • Ablation Studies • Shock Tubes •
- Wind Tunnels • Rocket Nozzles • Bearings •
- Rotating Shafts • Drums, etc. • Piston Ring Temperatures • Gun Barrels • Internal Combustion Engine Walls • Materials Evaluation •
- Heat Transfer • Hot Moving Wires and Rods • Metal Extrusions • Stampings •
- Plastic Extrusion • Injection Molds •
- Friction Tests • Boundary Layers •
- Automotive Brake Bands • Glass Molding • Zinc Die Casting •
- High Velocity Gases •

Complete details in Section E of our Handbook. Ask for it. It's FREE!

FREE TEMPERATURE MEASUREMENT HANDBOOK/CATALOG

- Over 225 pages • More than 9000 products • Complete ANSI Calibration tables • 16 pages of application notes • 7 technical articles on transient Temperature Applications and Heat Transfer • Industrial Research and Aerospace Data Included •

Call Mass. (617) 872-4811 or TELEX 951711 for FREE Handbook

NANMAC CORPORATION
Foremost in Temperature Measurement

526 South H St., Lake Worth, FL 33460-USA
9-11 Mayhew St., Framingham Ctr., MA 01701-USA



Circle Reader Action No. 405

MEASURE RPM INSTANTLY Pioneer Model DT36M Digital TACHOMETER

Continuous Digital Readout

60 to 50,000 RPM

Visible Light Beam makes aiming easy

No Wires or Mechanical Connections Required

Memory stores last reading

with memory

A highly accurate photoelectric digital display tachometer incorporating Pioneer's own patented circuitry. Accuracy: ± 1 RPM over entire range • Large 5 Digit LCD Display • Crystal Controlled Time Base for stability • Battery operated using 2-1.5 V "AA" batteries 1-9V alkaline battery • No calibration required



Made in U.S.A.
*U.S. Pat. 4,031,466

Circle Reader Action No. 305

Pioneer Model DS-12V Battery Powered PORTA-STROBE

Ideally suited for a wide range of industrial, institutional and educational applications. Sturdy and compact, it can be operated for visual and digital measurement of rotary, reciprocating or linear motions. Adjustment also allows viewing the action in slow motion to study interacting parts. Can also be used as a remote electronic digital tachometer for direct measurement of RPM (speed) without special reflective tape or markings. RPM results are updated and recorded approx. every half second on a 5-digit LED display. Can also be operated on 120V 60Hz AC line. Speed range 0 to 12,000 RPM with accuracy to 1 RPM.

VISUALLY STOPS MOTION



THE **PIONEER**

ELECTRIC & RESEARCH CORPORATION
743 Circle Avenue • Forest Park, Illinois 60130 • Phone 312/771-8242

Circle Reader Action No. 377

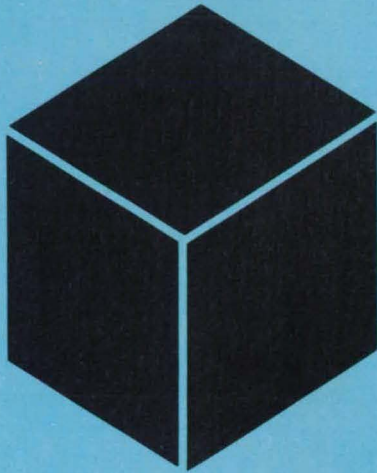

Hardware, Techniques, and Processes

- 80 Low-Gravity Alloy Studies on Aircraft
- 82 Monitoring Prepregs As They Cure
- 84 Low-Cobalt Powder-Metallurgy Superalloy
- 85 Making High-Porosity Alloy Spheroids
- 86 Reducing Sodium Contamination in MOS Devices
- 86 Pressure-Sensitive Resistor Material
- 87 Colorless Polyimide Containing Phenoxy-Linked Diamines

Low-Gravity Alloy Studies on Aircraft

Controlled solidification can be continued through many dives.

Marshall Space Flight Center, Alabama

A procedure for directional solidification of alloys under low and high gravity can be carried out aboard aircraft during parabolic arcing flight and pullout from dives. The procedure allows an experiment to be continued over repeated maneuvers. Since each dive gives 20 to 30 seconds in which gravity is 0.001 to 0.1 its normal value, and since an aircraft may make about ten low-gravity maneuvers in a mission, the technique allows substantial time to conduct a low-gravity experiment.

In directional solidification, the liquid/solid interface is advanced slowly through a rod of the sample alloy. The solidification continues during several aircraft maneuvers (see figure). The known solidification rate of the sample can then be correlated with accelerometer data to find the gravity value during solidification for any point in the sample. The thermal gradient and solidification rate are controlled independently.

The process uses a furnace canister containing a resistance heating element on top of a portable quench-block water-

circulation system. The sample is placed in a 40-centimeter-long, 1.25-centimeter-diameter vertical alumina crucible, which is encircled by the furnace canister. The furnace is translated along the crucible by a motor and gear train, first melting and then solidifying the sample as it proceeds. The results of a low-gravity experiment on a hypereutectic cast-iron sample suggest that low gravity — and the consequent absence of convection and flotation — promotes the incorporation of large graphite flakes into the solidification front.

This work was done by Peter A. Curreli, Mary H. Johnston, Robert E. Shurney, Wendy S. Alter, D. M. Stefanescu, and J. C. Hendrix of Marshall Space Flight Center. For further information, Circle 26 on the TSP Request Card.

Inquiries concerning rights for the commercial use of this invention should be addressed to the Patent Counsel, Marshall Space Flight Center [see page 21]. Refer to MFS-25967.

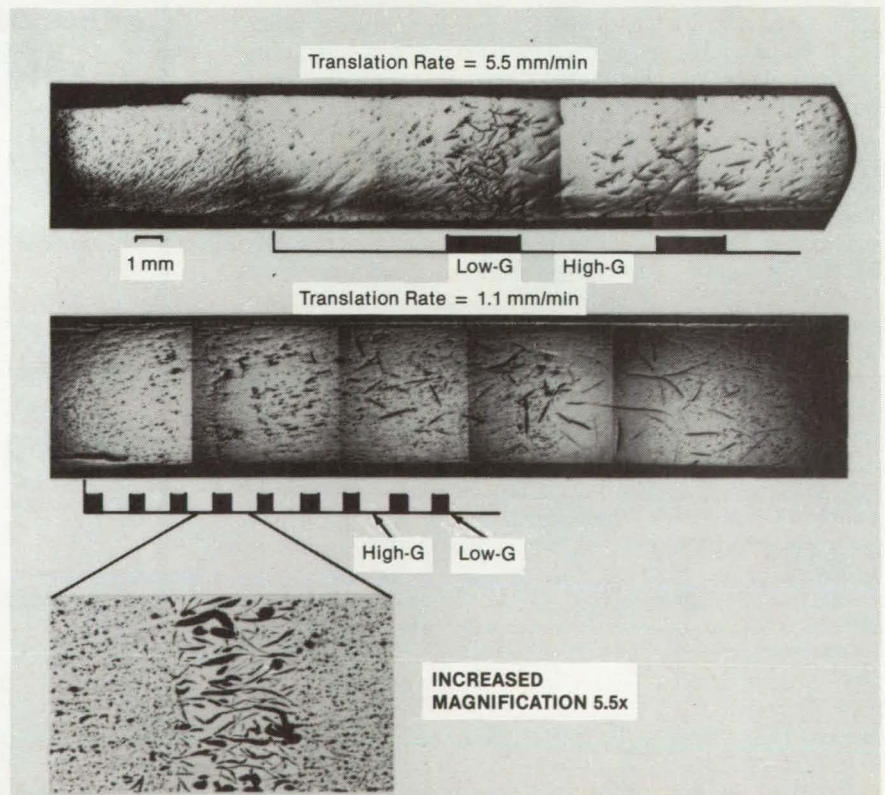

Composite Micrographs of directionally-solidified hypereutectic cast iron show two growth rates. The bands of larger graphite flakes correlated with sample solidified during low-gravity.

SCHOTT ... Precision Optical Glass Made in America and More!!!



Schott Glass Technologies is geared to work with the largest production quantities or the smallest prototype development right here in the USA. Our 300,000 square feet of manufacturing facilities, backed by our scientific knowledge and technical skills, are ready to work for you at every stage of your program.

Our in-house research and development is among the most modern of its kind

anywhere. And we have the marketing and sales know-how to assure you that products made from Schott materials or components get to your customers on time and to specification.

And, above all, Schott Glass Technologies has the widest range of precision optical glass and components available in the Western Hemisphere today.

OPTICAL DIVISION

- OVER 250 TYPES OF OPTICAL GLASSES
- FIBER OPTICS RODS
- HIGH HOMOGENEITY GLASS BLANKS FOR MASSIVE OPTICS
- ZERODUR® — LOW EXPANSION MATERIAL
- PHOSPHATE AND SILICATE LASER GLASSES
- CERENKOV COUNTERS

COMPONENTS DIVISION

- CRT FACEPLATES
- SCIENTIFIC FILTER GLASS
- INTERFERENCE FILTERS
- CRT CONTRAST ENHANCEMENT FILTERS
- FIBER OPTICS SPECIALTIES
- B-270/CLEAR SHEET GLASS
- X-RAY LEAD GLASS
- RADIATION SHIELDING GLASS AND WINDOWS

OPHTHALMIC DIVISION

- CROWN GLASS — CLEAR AND TINTS
- 1.60 LIGHTWEIGHT CROWN GLASS
- HIGH-LITE® — HIGH INDEX LOW DENSITY GLASS
- SUN MAGIC® PHOTOCROMICS — FOR SUNWEAR
- PHOTOCROMICS — FOR PRESCRIPTION
- INDUSTRIAL SAFETY GLASS
- UV FILTERING CROWN
- SPECIALTY GLASS

TECHNICAL SERVICES

- CONTRACT RESEARCH AND DEVELOPMENT
- CUSTOM MELTING
- ANALYTICAL/PHYSICAL/OPTICAL MEASUREMENTS

— and the list goes on . . .

Our commitment . . .

**Research & Development, Manufacturing, Sales, Service — Total Capability
. . . your advantage.**

 **SCHOTT™**
GLASS TECHNOLOGIES INC.

400 York Ave., Duryea, Pennsylvania 18642
(717) 457-7485 TWX 510-671-4535
Telefax (717) 457-6960

Circle Reader Action No. 383

Monitoring Prepregs As They Cure

Quality IR spectra are obtained in a dynamic heating environment.

Langley Research Center, Hampton, Virginia

A new technique obtains quality infrared spectra on graphite-fiber-reinforced, polymeric-matrix-resin prepregs as they cure. An analysis of these spectra provides insight into molecular-level changes in the matrix resin that accompany the processing of prepregs into composites.

This technique resulted from a modification of the diffuse reflectance/Fourier transform infrared (DR/FTIR) technique previously used to analyze environmentally exposed cured graphite composites [see "Resin Characterization in Cured Composite Materials" (LAR-13172) on page 103 of *NASA Tech Briefs*, Vol. 9, No. 1]. The technique should contribute to a better understanding of prepreg chemistry/temperature relationships and to the development of more efficient processing cycles for advanced materials.

Chemical characterization of prepregs, particularly those containing thermoset matrix resins, is generally limited to analyses on neat resins or analyses during the initial stages of prepreg cure. This is because standard tests require the sample to be soluble or transparent. Since cured graphite prepregs or composites are neither, much desirable fundamental information on these materials has been previously inaccessible.

The in situ DR/FTIR experimental arrangement is shown in Figure 1. A small programmable-temperature heater was fabricated to replace the sample mount supplied with a commercially available diffuse-reflectance optical accessory. The entire device is placed in the sample compartment of an FTIR spectrometer. The sample can be moved vertically by an adjustment

screw operating against spring pressure and horizontally by a sliding mount in the base of the reflectance accessory. Thus, the prepreg sample can be placed in a position at the focal point of the optical system to optimize the signal reaching the detector.

The sample is heated by a ceramic heater controlled by a temperature programmer. The programmer receives signals from a thermocouple placed between the heater and the silica fiber insulation. A second thermocouple, placed in contact with the prepreg surface, measures the actual sample temperature. The heater can be programmed to raise the sample temperature linearly to 750° F (400° C) at rates from 2° to 15° F/min (1.1° to 8.3° C/min).

Isothermal analyses are also possible. Normally, 100 FTIR scans are taken at

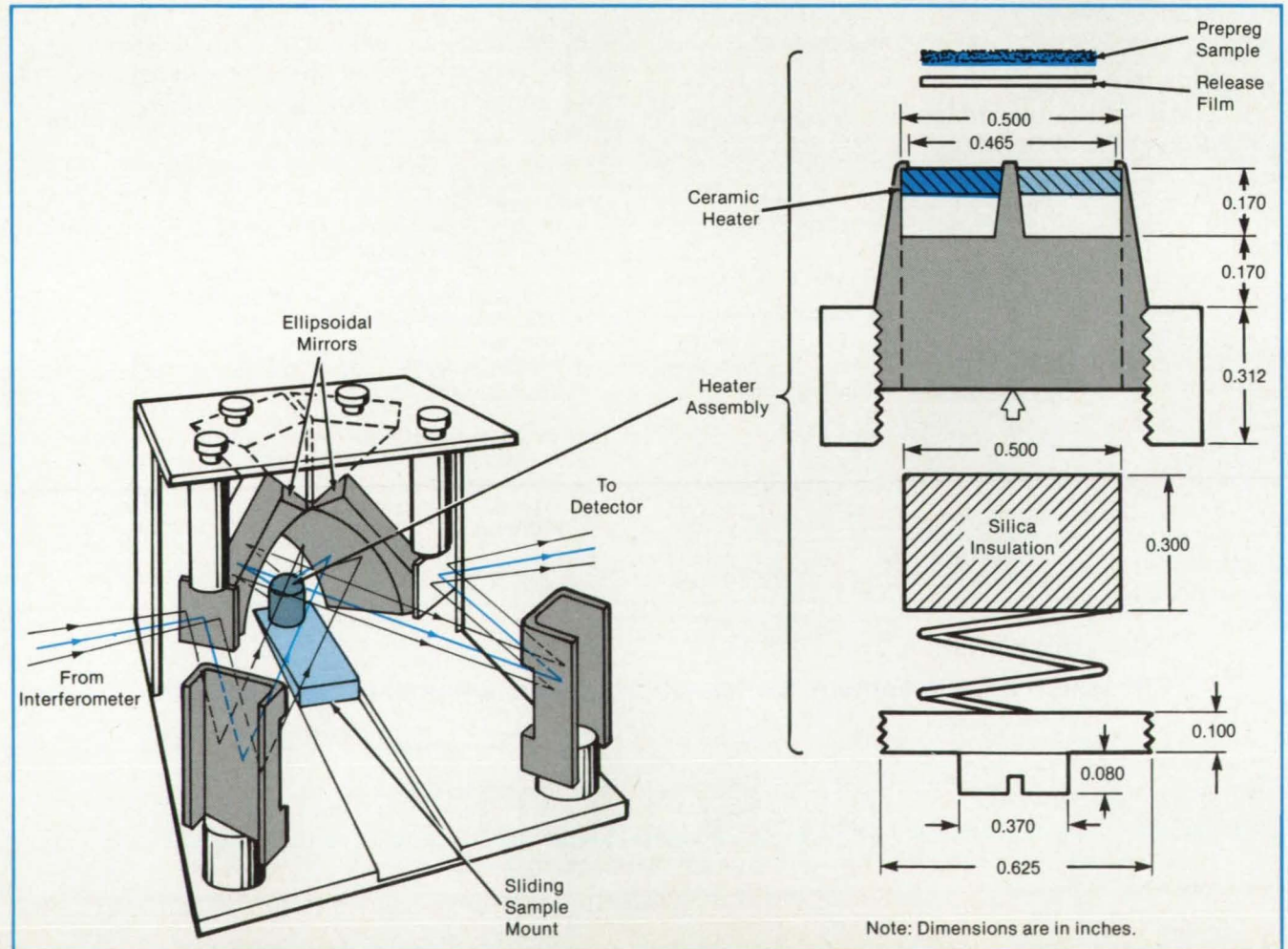

Figure 1. This DR/FTIR Apparatus obtains IR spectra while the prepreg cures.

0.5 s/scan and 4 cm^{-1} resolution while the sample is being heated. The scans are then averaged and filed. This procedure is automatically repeated every minute. When an analysis is complete, infrared spectra at any desired temperature interval can be reported. Easily interpretable spectra are obtained.

Figure 2 shows spectra of a graphite fiber/addition-polyimide resin prepreg being heated at 15° F/min . Although many spectra were obtained on this sample, only room temperature, 380° F (193° C), and 615° F (324° C) spectra are shown. Since the graphite fiber makes no contribution to the spectra, all absorption bands are due to the polymeric matrix resin. Changes in the spectra with temperature, which relate to changes in resin molecular structure due to cure, are apparent. For example, amine, ester, and acid groups at room temperature reacted to form imide groups by the time the prepreg had reached 380° F . Further heating caused the resin to crosslink or fully cure as evidenced by the loss of a band at 842 cm^{-1} . An analysis of all spectra obtained on this prepreg could reveal additional details about the cure process.

This in situ DR/FTIR technique has been used to study numerous prepreg and adhesive systems. Quality spectra on these materials have been obtained for the first time. The information gained is being corre-

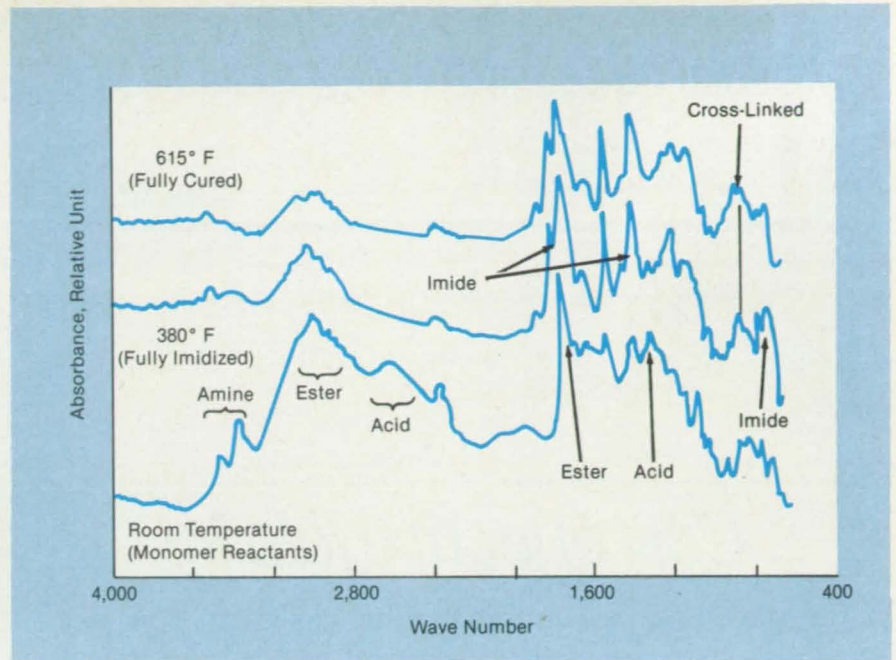

Figure 2. In situ DR/FTIR Spectra of graphite fiber/addition polyimide matrix resin prepreg are shown during cure.

lated with other process monitoring techniques such as dielectrometry in an effort to develop more efficient processing parameters for high-performance materials

This work was done by Philip R. Young of

Langley Research Center, John R. Gleason of the U.S. Army Structures Laboratory, and A. C. Chang of Kentron International, Inc. For further information, Circle 9 on the TSP Request Card. LAR-13335

**THE GOOD NEWS IS
WHAT WE PUT IN THIS BOX.
BUT THE GREAT NEWS IS
WHAT YOU GET OUT.**



INTRODUCING SONIX
DIGITAL AIR PRESSURE STANDARD

Sonix is here! It's the new pressure transducer that's small, accurate, rugged and stable. And best of all, it outputs data in corrected engineering units.

Because Sonix is a smart transducer, its applications go far beyond calibration of other transducers. And since the internal micro-computer compensates for systematic and temperature-dependent errors, you get reliable, repeatable results.

To find out more great news, call or write PSI...the leaders in digital pressure measurement technology.

- $\pm 0.01\%$ F.S. accuracy/stability
- Corrected digital output
- Applications include metrology, flight test and lab calibration

PSI PRESSURE SYSTEMS

15 Research Drive, Hampton, VA 23666
(804) 865-1243

Circle Reader Action No. 378

Low-Cobalt Powder-Metallurgy Superalloy

Highly-stressed jet-engine parts could be made with less cobalt.

Lewis Research Center, Cleveland, Ohio

Cost effective fabrics for people who can't afford failures.



Aerospace...Defense...Composites... Safety Apparel...Filtration

More than 300 fabrics engineered to exacting performance specifications are being used to insulate, dampen, seal, filter, suppress noise, retard fire, protect people and resist hostile environments. Tex-Tech Industries has the problem-solving experience and manufacturing capabilities to produce fabrics that exceed your expectations of performance.

We can help shape your ideas from concept to production with the "material difference".

Contact Tex-Tech Industries, Inc., Main Street, P.O. Box 8, North Monmouth, ME 04265. Call (207) 933-4404.



Udimet 700* (or equivalent) is a common nickel-based superalloy that has been used in the hot sections of jet engines for many years. This alloy, while normally used in a wrought condition, can also be gas-atomized into a prealloyed powder-metallurgy (PM) product. This product can then be consolidated by hot isostatically pressing (HIP-PM condition) and formed into parts such as a turbine disk. Such jet-engine disks "see" both high stresses and temperatures to 1,400° F (760° C).

Udimet 700* (or equivalent), like most high-temperature alloys, contains several strategic elements. The standard chemistry of Udimet 700* (or equivalent) includes 17 percent cobalt, by weight. Research has been underway at NASA to reduce the consumption of cobalt, one of the most critical strategic materials. The prealloyed powder form of Udimet 700* (or equivalent) was targeted as a possibly modifiable material, which, if successful, would reduce cobalt consumption.

The nominal composition (in weight percent) of the modified alloy is 15 chromium, 8.5 cobalt, 5 molybdenum, 3.5 titanium, 4 aluminum, 0.06 carbon, 0.02 boron, and the balance nickel. This modified chemistry was melted and argon-atomized into powder and packed into steel containers. The containers were sealed by welding in vacuo and hot isostatically pressed at 2,210° F (1,210° C). The alloy was then heat-treated by a partial solution at 2,065° F (1,130° C) and a four-step aging treatment at 1,600° F (870° C), 1,800° F (980° C), 1,200° F (650° C), and 1,400° F (760° C). The microstructure of the heat-treated alloy consists of a gamma matrix (nickel-base solid solution) containing 46 percent gamma prime (alloyed Ni₃Al) particles of three distinct average sizes: 0.5-, 0.2-, and 0.02- μ m diameters.

This microstructure is identical with that of HIP-PM Udimet 700* (or equivalent). The modified HIP-PM alloy has an improved creep-rupture life. For example, at 1,200° F (650° C), with a stress of 120,000 psi (825 MPa), failure occurred after an average of 428 hours as compared to 251 hours for HIP-PM Udimet 700* (or equivalent). With a stress of 130,000 psi NASA Tech Briefs, January/February 1986

(900 MPa), the life doubled to 152 hours, versus 74 hours for HIP-PM Udimet 700* (or equivalent). The advantage persisted at 1,400° F (760° C) where, with a stress of 70,000 psi (475 MPa), the life was 75 hours compared to 60 hours. Minimum creep rates were nearly identical.

Tensile tests at room temperature and

at 1,200° F (650° C) and low-cycle fatigue tests at 1,400° F (760° C) showed that the alloy had properties almost equivalent to those of HIP-PM Udimet 700* (or equivalent). These results appear to indicate that a useful substitute exists for standard (high-cobalt) HIP-PM Udimet 700* (or equivalent) and that its use can signifi-

cantly contribute to conservation of the strategic element cobalt.

(*Udimet is a trademark of Special Metals Corp., New Hartford, New York.)

This work was done by Fredric H. Harf of Lewis Research Center. For further information, Circle 94 on the TSP Request Card. LEW-14113.

Making High-Porosity Alloy Spheroids

Noncontact process yields a low-density, porous microstructure.

Marshall Space Flight Center, Alabama

Small spheroids of porous alloys with large surface area per unit volume are produced by a containerless processing method. Without container walls to serve as nucleation sites, an alloy cools to well below its normal freezing point without solidifying. Solidification then proceeds rapidly; the interdendritic liquid is pulled out by the growing crystals, resulting in a porous microstructure. The more rapid the cooling rate, the faster the crystals grow and the more porous the solid becomes.

The process has been used to prepare porous Ni/Al₃ alloy. Powdered Ni/Al₃ was melted in a bell jar over a 100-foot (30-meter) drop tube. The metal at a temperature of 100° to 200° C above melting was forced under gas pressure through an orifice, forming droplets that fell to the bottom of the tube, cooling as they fell. The droplets made no contact with other objects until they struck the bottom of the tube.

The large droplets did not have enough time to solidify during their fall. They simply splatted on the tube bottom and solidified there. They were much less porous than the small droplets, which solidified completely before reaching the bottom (see figure). The density of the small drops ranged from one-sixth to one-half that of the bulk alloy.

In a related experiment, alloy samples were melted and resolidified while suspended in an electromagnetic levitation apparatus. This method of containerless processing was less successful than the drop-tube method. Specimens were less porous because they could not be cooled as rapidly as in the drop tube.

The drop-tube method is likely to be useful in creating porous microstructures from other materials including oxides, carbides, and organic materials. Other means of containerless processing — acoustic or air-jet levitation, low-gravity NASA Tech Briefs, January/February 1986

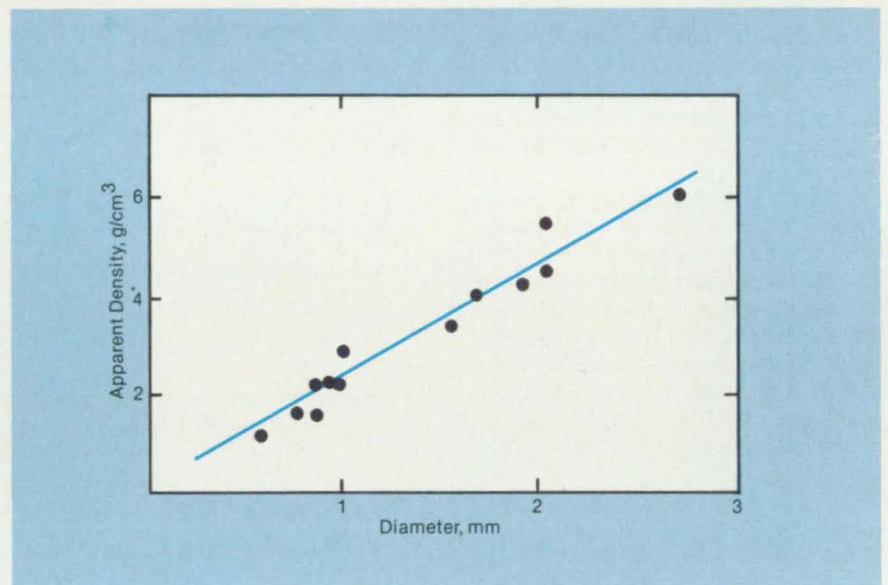

Small Drops Are Less Dense and more porous than large ones, as shown on the graph. Below are two examples of porous microstructures.

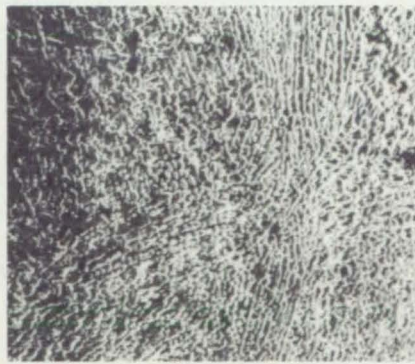

Ni/Al₃ SPHERE, 0.65 mm DIAMETER
DROP-TUBE SOLIDIFICATION

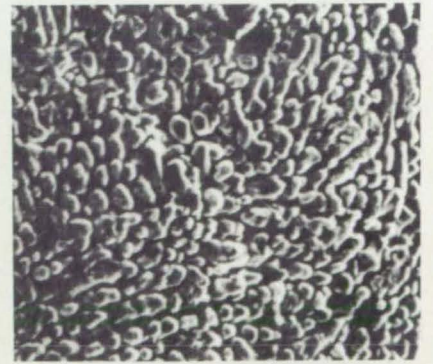

Ni/Al₃ SPHERE, 0.65 mm DIAMETER
DROP-TUBE SOLIDIFICATION

float melting, melt spinning, or jet spraying, for example — might be adapted to the process. The important conditions for the process are that the material solidify without contact in the absence of strong decelerating and gravitational forces.

This work was done by Edwin C. Ethridge, Peter A. Curreri, and Michael

Kelley of Marshall Space Flight Center. For further information, Circle 42 on the TSP Request Card.

Inquiries concerning rights for the commercial use of this invention should be addressed to the Patent Counsel, Marshall Space Flight Center [see page 21]. Refer to MFS-25997.

Reducing Sodium Contamination in MOS Devices

An electric field would drive positive ions to the surface.

Marshall Space Flight Center, Alabama

A proposed method of removing positive ions from the oxides in metal-oxide-semiconductor (MOS) transistors and integrated circuits would further ensure freedom from contamination by sodium and other mobile positive ions. Such contamination can change the threshold voltage of MOS devices and produce other adverse effects. The new method is intended to supplement established methods of minimizing ion contamination, such as scrupulous cleanliness in processing, purging with hydrogen chloride to react with and remove contaminants, and growing an extra-thick gate oxide, then etching it to remove the large portion of contaminants that are concentrated near the surface.

In the new method (see figure), a steady electric field is applied to silicon wafers while gate oxide layers are grown on them at about 1,000°C and while the wafers cool to room temperature after growth. The wafers would be held in an oxidation carrier boat with their surfaces perpendicular to the electric field. A low dc voltage on plate electrodes at the ends of the boat (or spaced along the boat) would produce the field.

The field would push the positive ions toward the negative electrode, and the ions would move readily in that direction because they are highly mobile in the oxide at the growth temperature. The ions thus gather at the oxide surface and remain there when the wafers have cooled because the ions are no longer so mobile and cannot redisperse at the lower temperature. The standard oxide etch that follows oxide growth thus removes the positive-ion contaminants along with the surface layer of the oxide.

Various other arrangements of the field

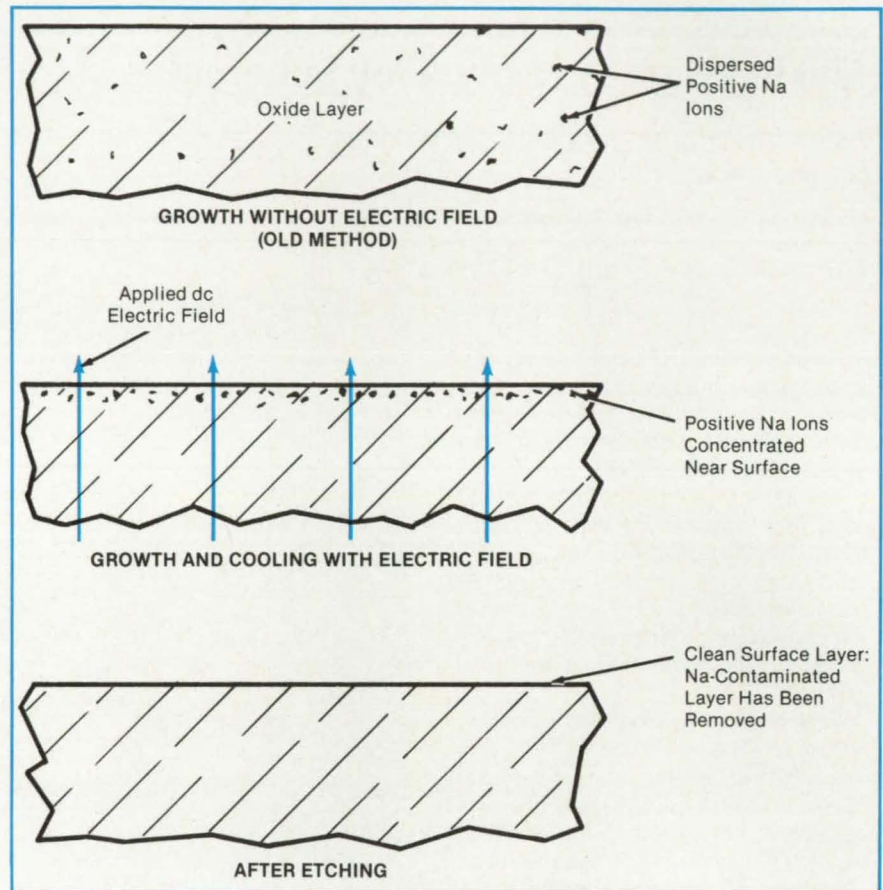

An **Electric Field** is applied during oxide growth to push mobile Na^+ ions to the surface. After cooling from the growth temperature, the field is turned off and the Na^+ -contaminated surface layer etched away.

electrodes are possible. For example, the electrodes could be mounted outside the oxidation furnace tube instead of on the boat.

This work was done by Robert F. Dehaye and William R. Feltner of Marshall Space Flight Center. No further documentation is available. MFS-28034

Pressure-Sensitive Resistor Material

Low-conductivity particles in rubber offer a wide dynamic range.

NASA's Jet Propulsion Laboratory, Pasadena, California

A resistor for which the resistivity decreases smoothly with increasing pressure is a promising candidate as a tactile sensor for robots and remote manipulators.

The sensor consists of particles of relatively low conductivity embedded in rubber. The resistance of the sensor decreases by about 100 times as the pressure on it in-

creases from zero to 0.8 MN/m².

The embedded particles can be antimony, silicon, magnetite, or nodular graphite. For maximum resistance change, the

NASA Tech Briefs, January/February 1986

particles should be coarse, measuring one-quarter to one-half the thickness of the sensor. They should be uniform in size and shape, angular, hard, and resistant to wear. Compound semiconductors such as PbS, FeS, Fe₃C, and Fe₃P are also promising particle materials.

The rubber matrix should wet the surface of the particles as little as possible, or the resistivity will be too high. Preferably, the rubber should have high tear resistance and low mechanical hysteresis. In the experimental tests of candidate particle materials, room-temperature-vulcanizing silicone and castable urethane were used.

Sieved particles ranging in size from 180 to 250 μm are mixed with uncured silicone rubber in the proportion of 50 percent or

more by volume. One part of tin octoate is added as a vulcanizing agent for each 100 parts of silicone and mixed in until the composite has become almost too stiff to be moved. The mixture is spread roughly over a molding plate, and another plate is placed over it. The assembly is squeezed in a vise and allowed to cure. Although the rubber cures enough to permit handling at room temperature in about 45 min, its mechanical properties are best when it is cured for several more hours at 140° F (60° C) after the initial cure and removal from the mold. The resulting rubber layer is about 25 mils (635 μm) thick.

In laboratory tests, nodular graphite, magnetite, and highly doped silicon worked well. The nodular graphite, how-

ever, was too coarse to permit sheets less than 50 mils (1.3 mm) thick to be made from it. Crushing the nodular graphite converted it to flake graphite; the flakes tended to align themselves in the matrix, an arrangement less favorable to conduction than is a random orientation.

This work was done by Eugene R. du Fresne of Caltech for NASA's Jet Propulsion Laboratory. For further information, Circle 25 on the TSP Request Card.

Title to this invention has been waived under the provisions of the National Aeronautics and Space Act (42 U.S.C. 2457(f)), to the California Institute of Technology, Pasadena, CA 91125. NPO-16537

Colorless Polyimide Containing Phenoxy-Linked Diamines

Tough, optically transparent films are produced.

Langley Research Center, Hampton, Virginia

The need exists for high-temperature, flexible polymeric films and coating materials that have high optical transparency in the 300- to 600-nm range of the electromagnetic spectrum for use on antennas, solar cells, and thermal-control coatings. Because of their inherent toughness, flexibility, low density, remarkable thermal stability, radiation resistance, and mechanical strength, linear aromatic condensation polyimide films have excellent potential. However, these films are known for their bright yellow color. Depending on thickness, commercial aromatic polyimide film was found to be only about 70 percent transparent at the 500-nm solar wavelength of interest. Further, the transparency upon aging drops to as low as 30 percent.

A process for preparing aromatic condensation polyimide films containing phenoxy-linked diamine monomers produces films that are essentially colorless. The process involves two conditions:

- purification of both aromatic diamine and aromatic dianhydride monomers and the solvent used as a medium and
- separation of chromaphoric centers and reduction of both inter- and intrachain electronic interactions, which cause absorption in the ultraviolet-to-visible region by introducing phenoxy or thiophenyl "separator" groups and isomeric (*m,m'*- or *o,p'*-oriented) diamines into the polymer molecular structure.

Both conditions must be satisfied to produce polyimide films with maximum optical transparency.

In the process, a highly-purified aromatic

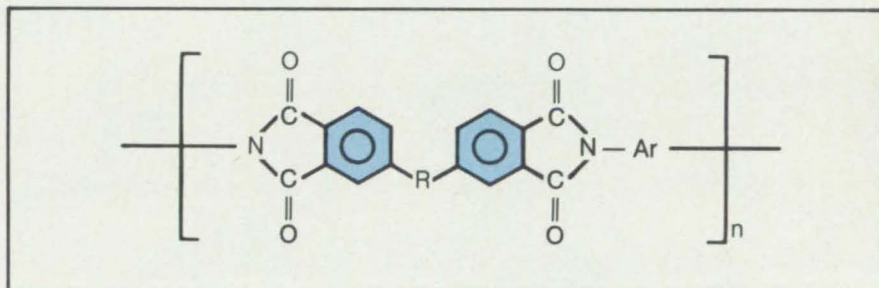

Polyimides Having This Molecular Structure form tough, transparent films. The films are made transparent by careful control of manufacturing conditions, including the use of highly purified monomers.

matic diamine is dissolved in a distilled amide-type solvent such as dimethyl acetamide. A highly purified dianhydride is then added to the diamine solution at room temperature to form a polyamic acid. This resin is then spread onto a glass plate to form a film, using a doctor blade with a specified blade gap. The polyamic acid film is then thermally converted, by heating to 300° C, to an optically-transparent polyimide film housing the molecular structure shown in the figure. All of the highly optically-transparent polyimide films produced have meta- or *o,p'*-oriented aromatic diamines and phenoxy groups in their molecular structures. The use of highly purified monomers containing oxygen-linked phenoxy groups and *o,p'*- or *m,m'*-orientation in the diamine proved successful for reducing chromaphoric centers, conjugation, and overall charge-transfer-complex formation in the polymer.

The films obtained have 90-percent

transparency at the visible wavelength of 500 nm, compared with 60- to 70-percent transparency for commercial polyimide film of the same thickness. It is anticipated that these optically transparent/achromatic films will prove highly useful as film and coating materials for aerospace and other applications where high transparency and thermal stability are necessary properties. This improvement in transparency has been made at no sacrifice in thermal stability, flexibility, toughness, or mechanical properties of the polymer.

This work was done by Anne K. St. Clair and Terry L. St. Clair of Langley Research Center. For further information, Circle 98 on the TSP Request Card.

This invention is owned by NASA, and a patent application has been filed. Inquiries concerning nonexclusive or exclusive license for its commercial development should be addressed to the Patent Counsel, Langley Research Center [see page 21]. Refer to LAR-13353.

Introducing a revolutionary new composite materials tooling system

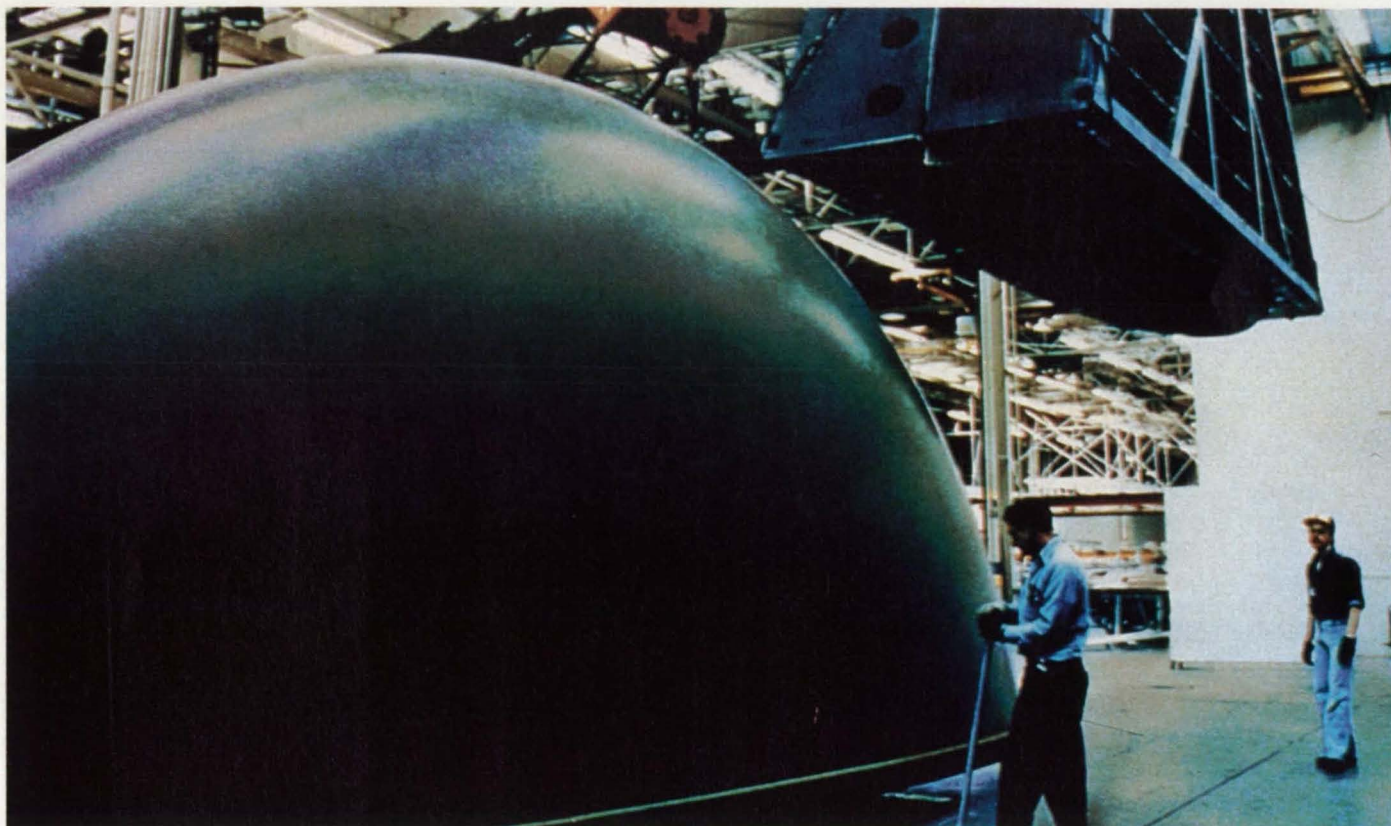

ToolRite® is a complete tooling materials system that uses low cure temperature prepregs formulated exclusively for tooling. Compared with conventional wet lay-up, it is faster, cleaner, and easier to handle. Tool life is 500% longer. And, being a prepreg system, it assures uniform resin distribution, virtually free of voids and pockets, so thermal cycling has less effect. Heat distributes evenly. Warping is 70% less.

Compared to metal tooling, the ToolRite System provides exceptional dimensional accuracy and thermal stability. Tools and parts heat up and cool down together, at the same rate. Damage and distor-

tion are practically eliminated. Parts come off the tool faster, too.

And because of lower mass,

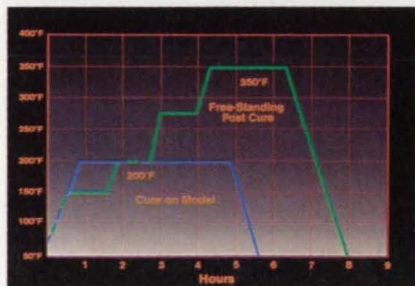

The ToolRite System cures completely on a master model at 200° to 210°F. It can be removed from the master and post-cured, free-standing, at 350° to 375°F—with service temperatures of more than 400°F.

the ToolRite System saves energy—whether you cure by vacuum bag or autoclave.

ToolRite is no ivory tower idea fresh from the drawing board. It is already in use in more than 2,000 tools throughout the aerospace industry worldwide. Here is how two of these users are benefiting from the unique properties of the Fiberite ToolRite System.

Shell lay-up time on the AWACS radome tool was cut an estimated 40% due to fewer plies of thicker, more easily applied material.

One of the world's largest high temperature fiberglass/epoxy tools, the AWACS radome lay-up mandrel is 12½ ft. high, 5½ ft. wide and 30 ft. long at the base. In the past,

ToolRite[®] from Fiberite

with wet lay-up, Boeing fabricated the mandrel in two sections and cured each half separately. Thus, there were three cure cycles—Left, Right, and Spliced. With the ToolRite System, as specified by Boeing, the halves can be laid up *and spliced*, then cured in a single cycle. This saves four cycles when building the pair of mandrels required.

Large size and close dimensional tolerance make such a tool expensive to fabricate. But, with the ToolRite System, Boeing has been using the tool for three years and still does not see the end of its useful life. Also, compared with previous tooling, labor for tooling rework to retain vacuum integrity has been cut more than 90%.

As a result of the change from wet lay-up to the ToolRite System, physical properties of the tool have improved greatly. Flexural strength at 350°F is nearly twice that of the previous systems.

"To date, we have over 500 cycles on some of our prepreg tools with no indication of leakage or thermal shock cracks."

*R.T. Williams, Manager
Composites and Bonded Structures
Teledyne/Ryan Aeronautical*

Ray Williams knows prepreg tooling. He has more than 700 ToolRite tools in inventory at Teledyne/Ryan.

"If you're building graphite, aramid or glass parts, you must match the thermal characteristics of the tool with the part," Williams says. "With interlocking curvatures, projections and tight radii, the tool and the part must expand and contract at the same rate, or you lose dimension."

Uniform resin distribution is important, according to Williams,

because resin-rich areas act as a heat sink subject to thermal shock, resulting in premature tool failure. "Using graphite prepreg, we project the life of our tools somewhere near 750 cycles. In addition, the tools are light, and easy to handle and store."

Designing with the ToolRite System has significant advantages over traditional design, according to Williams. "Designing one structure of composite tooling, we've



Is it possible to make an asymmetric part with composite tooling? Using the ToolRite System, Teledyne/Ryan Aeronautical designed this split graphite tool used to fabricate an engine intake duct for the AH-64 attack helicopter. Harbor Patterns, Inc., Los Alamitos, CA, built the tool.

been able to totally design out 11 different components. By eliminating part count and secondary operations, you can really begin to save money," he says.

You can get details on the ToolRite Prepreg System for composite tooling—and arrange a technical briefing for your management and an in-shop



Add Beech Aircraft to the growing list of ToolRite System users, which already includes Boeing, MBB, CASA (AirBus), BAe, Dassault and Teledyne Ryan. The upper and lower wing skin tools for the Beech Starship I (above) were fabricated using this revolutionary new prepreg tooling system for composite parts.

demonstration—just by picking up your phone. Call Clint Juhl or Kris Ralph at (714) 639-2050, and describe your project. Or use the coupon below.

Please send me a copy of your brochure showing step-by-step tool fabrication procedures using ToolRite Prepreg System. I am considering ToolRite materials for the following areas:

- | | |
|--|---|
| <input type="checkbox"/> Commercial Aircraft | <input type="checkbox"/> Missiles/Rockets |
| <input type="checkbox"/> Military Aircraft | <input type="checkbox"/> Recreational |
| <input type="checkbox"/> Helicopters | <input type="checkbox"/> Thermoforming |
| <input type="checkbox"/> Satellites/Space Vehicles | <input type="checkbox"/> Other _____ |

Name _____

Title _____

Firm _____

Address _____

City, State, Zip _____

Telephone _____ / _____

Application _____

Mail to: Michael A. Edwards,
Fiberite, 501 West 3rd Street,
Winona, MN 55987

FIBERITE[®]

AN ICI COMPANY



Books & Reports

90 Self-Contained Neutral-Buoyancy Suit

Books and Reports

These reports, studies, and handbooks are available from NASA as Technical Support Packages (TSP's) when a Request Card number is cited; otherwise they are available from the National Technical Information Service.

Self-Contained Neutral-Buoyancy Suit

A "dry suit" would add to the realism of zero-gravity simulations.

A report discusses a self-contained diving suit to be used in simulations of zero-gravity maneuvers in a space suit. The method, called neutral-buoyancy immersion, is useful in preparing astronauts for extravehicular activity.

In neutral-buoyancy immersion, a person clad in a modified space suit enters a water tank. Weights are attached to the suit until the wearer has balanced neutral buoyancy—that is, in the absence of body movement, the subject does not rise, sink, or rotate, but simply floats under the surface. The person then trains for space walks by maneuvering the body, learning tasks, and generally getting used to weightlessness.

The disadvantages of the present neutral-buoyancy techniques are due to an umbilical cord. Breathing air, cooling, ventilation, and communication are all supplied through this cord. In real space walks, however, astronauts carry self-contained life-support equipment in backpacks. The umbilical cord therefore detracts from reality. The test subjects, for example, cannot start a training session from an air lock with a closed hatch, as a space walk would start. The umbilical cord also tends to become ensnared in equipment, creating twisting, turning, and pulling forces on the wearer that do not occur in space.

The report recommends that a commercial "dry suit" used in self-contained underwater diving be modified to replace the space suit with its umbilical cord. The new suit should be equipped with a life-support backpack, including wireless acoustic-carrier voice communication. To feel like a space suit, the modified suit would include such key space-suit accessories as gloves, boots, helmet, and visor.

Tests on a modified dry suit showed that the concept is feasible. The report analyzes the requirements for a suit designed expressly for neutral-buoyancy immersion. Many parts of the suit are already available or could be fabricated readily with minimal development.

The report concludes that the proposed suit would closely approximate the sensation of zero gravity. The self-contained air supply, communication, and cooling would allow spaceflightlike flexibility of movement. The turnaround time between uses is only 2 hours, as opposed to 48 hours for the conventional space suit. Only four technicians would be needed to prepare the suit and assist the wearer in neutral-buoyancy tests; a conventional space suit needs many more technicians.

This work was done by Barry E. Boswell, Bilby J. Wallace, and Thomas G. Woods of McDonnell Douglas Corp. for Johnson Space Center. To obtain a copy of the report, "Manned Simulation of Zero-g Utilizing Neutral Buoyancy," Circle 20 on the TSP Request Card.

MSC-20424

Capture the Glory!

Now you can own this collector's print, commemorating Columbia's exploits, at an exceptional introductory price.

Noted aviation artist Ken Kotik has captured *Columbia* in all its glory to commemorate the completion of four test flights and the first operational mission, STS-5. This fine print—truly a collector's item—depicts the orbiter in full color, side view, with every feature crisply detailed.

Arranged beneath the ship, also in full color, are the five distinctive mission patches. But what makes Ken Kotik's work most unique is his method of creating a 'historical panorama' via individual vignettes surrounding the side view of *Columbia*.

Educational as well as eye-appealing, these scenes, which are expertly rendered in a wash technique, include such subjects as the orbiter under construction at Rockwell, on the launch pad, at touch-down and during transit on its 747 carrier. Concise copy, hand-written by the artist, accompanies each vignette. (*Important:* The greatly reduced print reproduced here is intended only to show style—at the full 32" by 24" size, all copy is clearly readable.)

About the artist.

Ken Kotik, a 37-year old Colorado native, has been a professional commercial artist for the past 14 years. In his own words, he "eats, drinks and sleeps flying." It shows in the obvious care and attention he brings to each print or mural. When not at his drawing board creating artworks for such prestigious institutions as the Air Force Academy, Ken can be found at the controls of his Schweitzer sailplane, in which he competes nationally. A self-taught artist, he specializes in airbrush-applied acrylic techniques. *Space Shuttle Columbia: The Pathfinder* is his first work on the space program, and the original art has been accepted by the Smithsonian Air and Space Museum for its permanent collection.

About the artwork.

Space Shuttle Columbia: The Pathfinder was printed in five colors, after individual press proving, on exhibit-quality 80 lb text 'Hopper Feltweave' textured paper. The feltweave texture yields properties most desirable for framing and display.

About ordering.

Each *Columbia* print comes packed in a sturdy mailing tube and will be shipped upon receipt of your order at the introductory price of \$9.95. Please allow two to three weeks for delivery. There is a one-time *first class* postage and handling charge of \$2.50 for each order. (If you order

three prints, for example, you still include only \$2.50 for postage and handling to cover the entire order.) To ensure that you receive your prints without delay, fill out and mail the coupon today, including check or money order only and local tax where applicable. If coupon has been clipped, mail your order to: NASA Tech Briefs, Columbia Print Offer, 41 E. 42nd St., New York, N.Y. 10017.

Actual size: 32" wide by 24" high—In full color!



Space Shuttle Columbia: The Pathfinder

(\$17.95 for two; \$26.95 for three; \$7.95 each additional plus postage and handling.)

ONLY \$9.95 EACH

MONEY BACK GUARANTEE

If not completely satisfied, return undamaged print, in wrapper, within 10 days for a full refund of print purchase price.

Mail to: NASA Tech Briefs
Columbia Print Offer
41 East 42nd St.
New York, N.Y. 10017



Note: One print \$9.95; two \$17.95; three \$26.95; each additional \$7.95, plus \$2.50 postage and handling per order.

Please rush _____ Columbia prints.
I have enclosed \$ _____ plus \$2.50
for *first class* postage and handling.
Total enclosed: \$ _____.

Name _____

Address _____

City _____ State _____ Zip _____

New York State residents add 7% sales tax.
New York City residents add 8.75% sales tax.

Please add my name to your mailing list
for future print offerings. SS-1

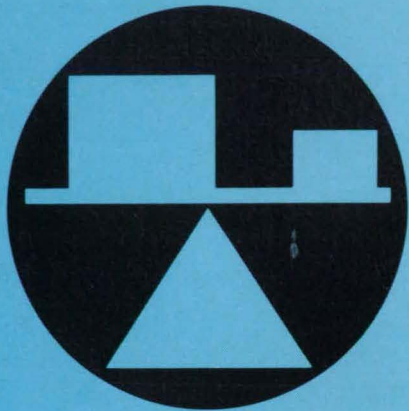

Hardware, Techniques, and Processes

- 92 Cradles for Support in Transit
- 93 Internally Wrenching Nut
- 94 Self-Alining End Supports for Energy Absorber
- 94 Combined Devices for Turbulent- Drag Reduction
- 96 Clip-On Extensometer
- 97 Precise-Conductance Valve Insert
- 98 Detecting Cavitation Pitting Without Disassembly
- 98 A Rapid Attachment of Strain Gages
- 99 Easy Accessible Camera Mount
- 100 Graphical Method for Predicting Steady-State Temperature
- 100 Ice Detector for Aircraft
- 101 High-Performance Heat Pipe With Screen Mesh
- 102 Measuring Gearbox Torque Loss
- 103 Measuring Heat-Exchanger Water Leakage
- 103 Optimized Bolted Joint
- 104 Laser Holder Aids Centering of X-Ray Head
- 105 Higher Sensitivity in X-Ray Photography

Computer Programs

- 107 Simplified Ride-Comfort Program

Cradles for Support in Transit

C-shaped cradles distribute weight of large objects.

Lyndon B. Johnson Space Center, Houston, Texas

A proposed system of cradles would support loads of a wide range of weight, shapes, and sizes for transportation. Originally developed for holding a satellite in the bay of the Space Shuttle orbiter, the concept is also adaptable to such terrestrial

uses as carrying odd-shaped equipment by truck.

A cradle set would consist of a single prime cradle and several basic cradles. Composed of a bar bent into a half circle, each cradle would have its own keel and

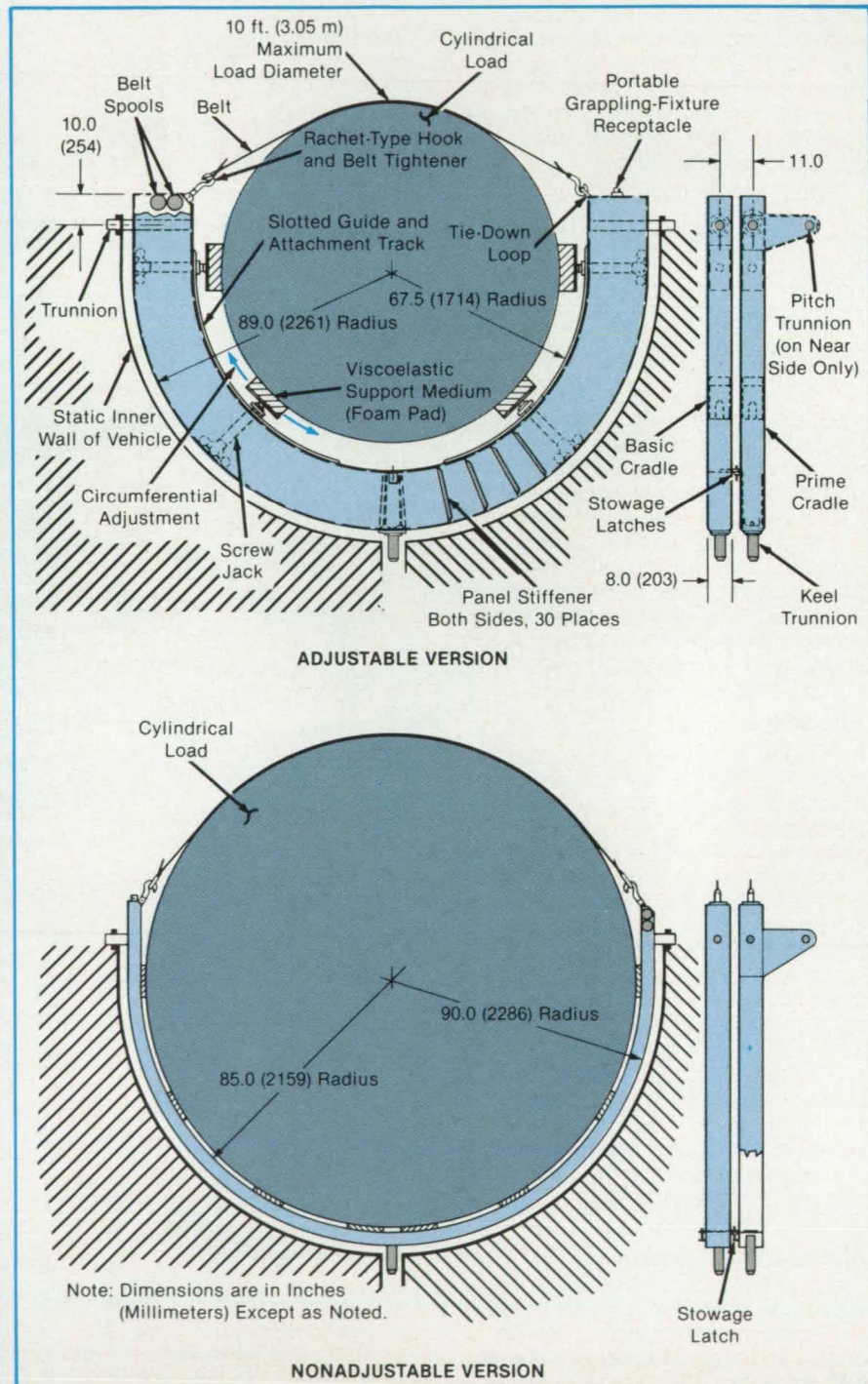

Figure 1. The **Screw Jacks Are Adjusted** so that the weight and inertia of the load are distributed fairly evenly to all the foam pads.

longeron trunnions that brace the structure by mating with receptacles in the vehicle and its own foam pads, on which the load rests (see figure). One 548-lb (249-kg) cradle would support up to 3,000 lb (1,361 kg); thus, a 15,000-lb (6,800-kg) object would require five cradles distributed along its length. Through their trunnions, the cradles would spread the weight of the load along the vehicle.

As shown at the top of Figure 1, the elastomeric pads could be mounted on screw-jack struts that can be moved in a radial direction. The positions of the pads could therefore be adjusted so that they bear against an irregularly shaped load. A non-adjustable version for large, regular cylindrical loads is shown at the bottom of Figure 1.

For storage, the cradles could be removed from the vehicle or stacked together at one end of the vehicle, as in Figure 2. A stowage latch on each cradle would secure it to its neighbor. A receptacle on each cradle would allow it to be handled by a remote manipulator for storage and deployment.

This work was done by W.H. Crane and H.T. Fisher of Lockheed Missiles & Space Co., Inc., for Johnson Space Center. No further documentation is available. MSC-20725

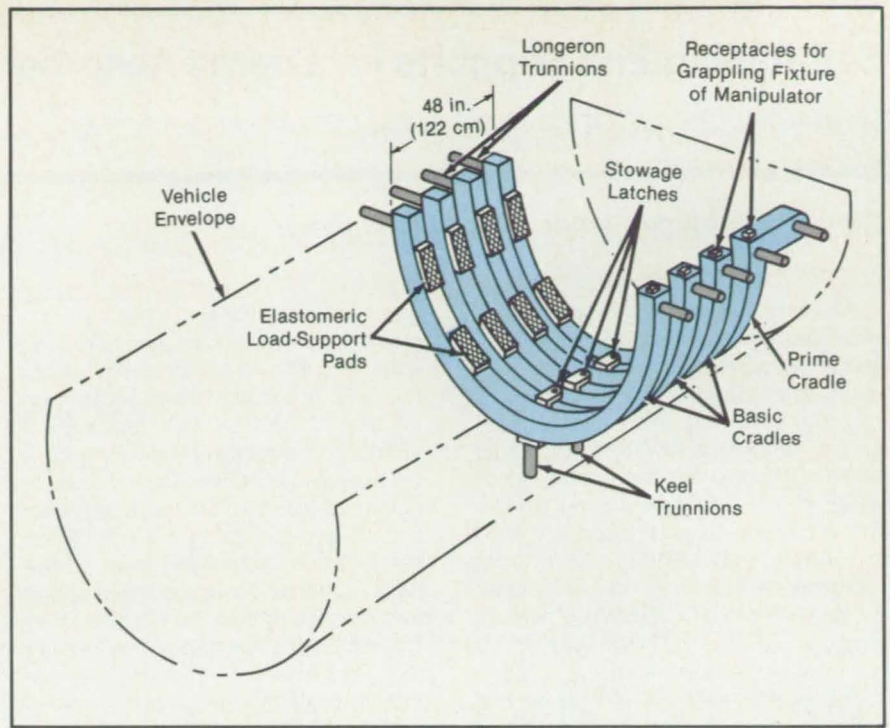

Figure 2. When Not in Use, Transport Cradles Nest Together as shown here. For deployment, they are separated and spaced evenly in the vehicle (here indicated in outline). The prime cradle differs from the basic cradles in that it has an additional longeron fitting to resist pitching movement.

Internally Wrenching Nut

Less space is needed for installation and removal.

Marshall Space Flight Center, Alabama

A nut for use with short bolts is torqued with an allen wrench (see figure). In contrast with standard hexagonal nuts, the new nut requires no external wrench clearance on the installation surface.

As with allen-head bolts, the nut can be held on the wrench temporarily by gravity, friction, or a sticky material and can be carried to the installation point through a narrow otherwise-inaccessible space. The new nut should have many uses in assemblies where space is limited, especially in the automotive and aircraft industries.

This work was done by Reuben G. Cortes of Rockwell International Corp. for Marshall Space Flight Center. No further documentation is available.

MFS-29068

NASA Tech Briefs, January/February 1986

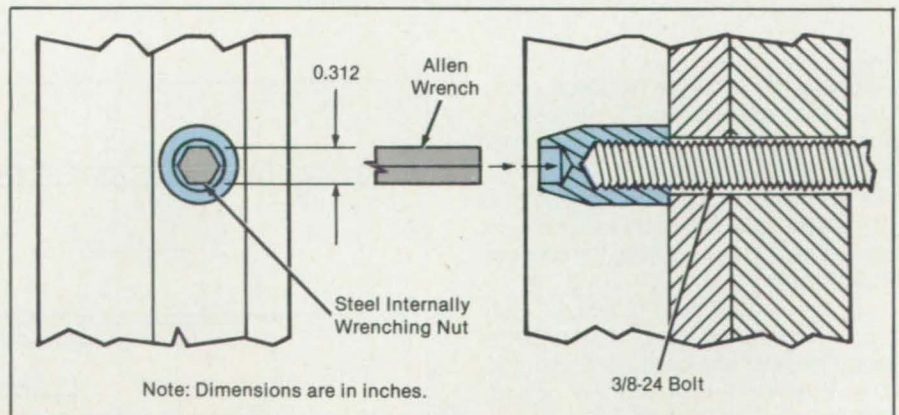

The Internally Wrenching Nut has a hexagonal wrenching hole like that of an allen-head bolt. It is installed or removed with an ordinary allen wrench. Although the bolt shown here has a 3/8-inch-24-thread, the concept is applicable to other thread sizes.



Self-Alining End Supports for Energy Absorber

Simple devices stabilize axially-loaded compressive members.

Langley Research Center, Hampton, Virginia

A method has been developed to stabilize the axial compressive loading of an energy absorber by the use of end supports (cap and plug) that pivot to compensate for off-axis loading. Previously, off-axis loading of only a few degrees could cause excessive bending, instability, or failure of the energy-absorbing device. The self-aligning supports described here are small, lightweight, and almost maintenance-free. Their use eliminates the alignment problem, opening up more applications and providing higher reliability for compressively-loaded energy absorbers.

The energy absorber is held by two end supports: an upper cap and a lower plug (see figure). The upper cap pivots below the contact point between the cap and the energy absorber. The load is transferred from the structure to the pivot, to the cap, to the energy absorber. It is essential that the pivot be located below the contact point between the cap and energy-absorber tube for loading stability. The same applies to the functioning and location of the pivot in the lower plug. The use of a cap-and-plug combination controls the direction of crushing, which in this case starts at the cap end and pro-

gresses toward the plug end.

The tube can be designed to crush at either end. The device aligns both ends of the tube to keep the force vector along the axis of the tube. The device is self-aligning and simulates physically a movable fixed-end condition. Column buckling of the tube is not a problem because such a tube is designed to crush at a load below the Euler buckling load. Furthermore, as the tube crushes, it gets shorter, thereby making buckling even less likely. The device may be particularly useful to designers working with composite tubes that, in crushing, act as brittle material and are difficult to control.

This work was done by Emilio Alfaro-Bou and Charles P. Eichelberger of Langley Research Center and Edwin Fasanella of Kentron International, Inc. No further documentation is available.
LAR-13295

The **Energy-Absorbing Column** is held by two end supports, which stabilize the column and tolerate misalignment. The column absorbs an excess load by collapsing lengthwise.

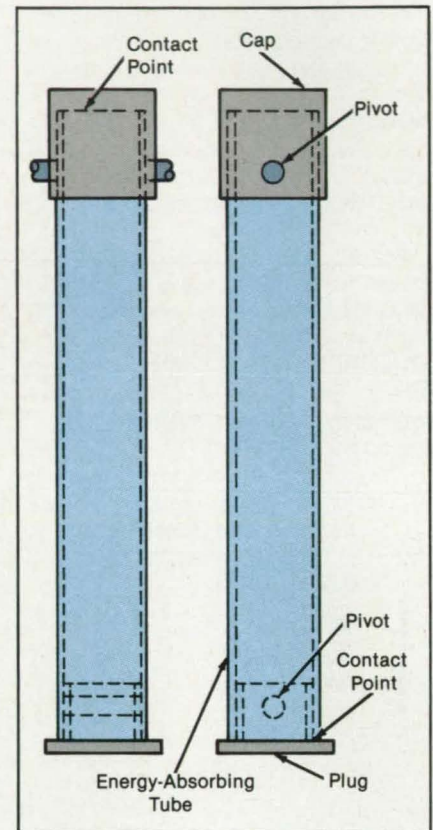

Combined Devices for Turbulent-Drag Reduction

Aircraft skin-friction drag can be reduced as much as 15 percent.

Langley Research Center, Hampton, Virginia

Energy conservation has been a driving force behind research into methods that can reduce the turbulent skin-friction drag on transport-aircraft fuselages. Reductions in fuselage skin-friction as small as 10 percent could potentially save \$250 million per year in fuel costs for the commercial airlines.

One effective drag-reduction technique involves the use of riblets. Riblets (see Figure 1) are longitudinal striations or grooves that are machined on an originally smooth surface. The grooves are aligned with the flow. The grooves have depths and spacings on the order of the turbulent wall-streak and burst dimensions

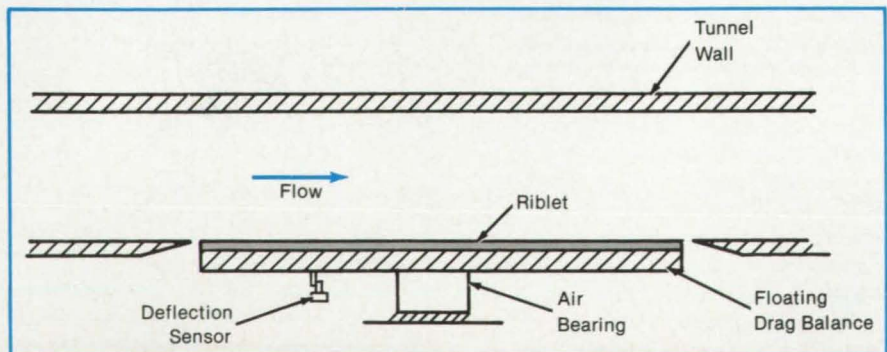

Figure 1. A **Riblet**, shown here in a wind-tunnel-test configuration, operates on the near-wall structure of a turbulent boundary layer.

THE COMPANY THAT SET THE STANDARD AT 3000 PSI, NOW RAISES IT TO 8000.



MBC. MORE THAN 25 YEARS OF EXPERIENCE IN HYDRAULIC RESERVOIRS AND ACCUMULATORS.

For almost three decades, MBC's hydraulic components have stood out among all others for one reason. They stand up. They stand up because there's no bladder, no piston, no leaks and no way to wear out. Even after millions of cycles on high performance aircraft, they're still standing tough.

Standards like these were first set by our maintenance-free and leak-free 3000 PSI hydraulic accumulators. And now, our 8000 PSI hydraulic components raise performance standards to a level unrivalled in the world.

WEIGH THE ADVANTAGES.

The advantages of MBC's patented welded bellows design

over typical piston and bladder types is considerable. Advantages like hermetically sealed barriers between the gas precharge and the hydraulic fluids. Advantages that overcome the hazards of leaking bladders, O-rings and seals.

WHY WAIT ANY LONGER?

While other systems at this pressure are still being tested, ours is ready

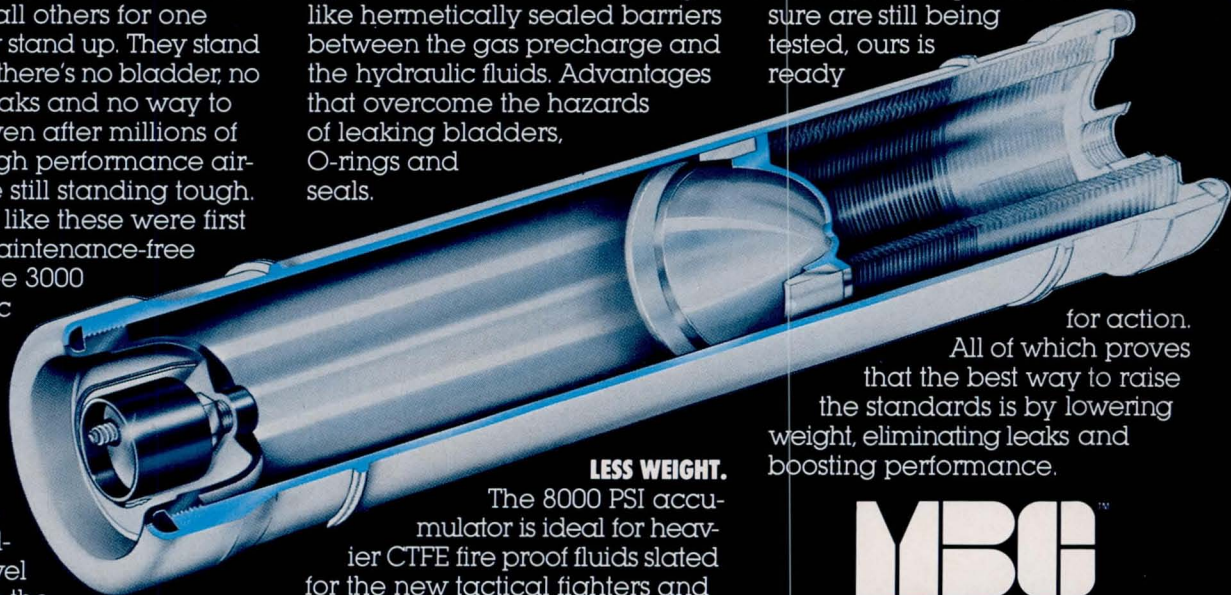

LESS WEIGHT.

The 8000 PSI accumulator is ideal for heavier CTFE fire proof fluids slated for the new tactical fighters and military transports. Weight reductions accrue by making it unnecessary to have charging lines, valves and pressure gauges throughout the aircraft.

for action. All of which proves that the best way to raise the standards is by lowering weight, eliminating leaks and boosting performance.

MBC

Metal Bellows Corporation

P.O. Box 8010, 200 Science Drive
Moorpark, CA 93021-8010
805/529-5800 Telex: 65-1483
Datafax: 805/529-5850

©1984 Metal Bellows Corp

and are designed to change the near-wall structure of the turbulent boundary layer. Properly optimized, the grooves reduce the net drag by 8 to 10 percent.

Another approach, using large-eddy-breakup (LEBU) devices, or turbulence manipulators or ribbons as they are sometimes called, has also demonstrated reductions in local skin friction and net drag in air for some laboratory conditions. The LEBU device (see Figure 2) consists of thin, ribbonlike strips or airfoils suspended parallel to the test surface and positioned within the turbulent boundary layer. A properly optimized LEBU configuration has been shown to reduce the net drag by 7 percent.

The present technique involves the combination of the two Langley-developed individual drag-reduction concepts: riblets and LEBU's. Since the riblets are designed to operate on the near-wall structure of the turbulent boundary layer and the LEBU devices are designed to operate on the large-scale outer structure and only indirectly on the wall structure, it is not evident that the drag-reduction performance of the riblet and LEBU would be

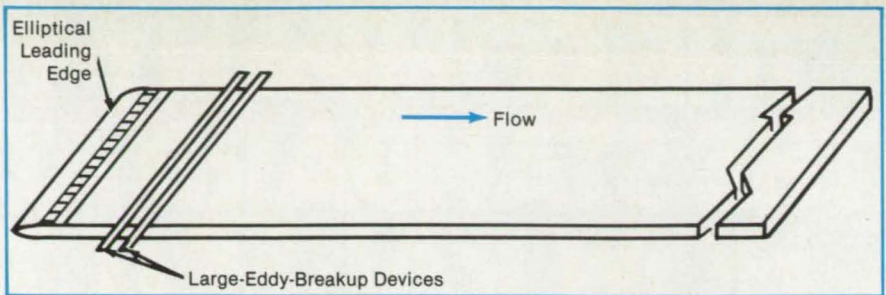

Figure 2. **Large-Eddy-Breakup Devices (LEBU's)** operate on the outer-wall structure of a turbulent boundary layer. Here, two LEBU's are shown on a test plate.

additive. However, tests conducted at Langley on a combined riblet and LEBU configuration have shown that the drag-reduction performances of the two devices are, in fact, approximately additive.

The combined technique can potentially reduce the net skin-friction drag by at least 15 percent on the turbulent boundary layer of an aircraft, representing a possible annual saving in fuel costs of \$300 to \$400 million for the U.S. commercial fleet. This technique could also be applicable to friction-loss reduction inside pipes and ducts, contributing to the increased efficiency of pumps, heat exchangers, air

conditioners, and other devices involving fluid flow.

This work was done by Michael J. Walsh, John B. Anders, Jr., and Jerry N. Hefner of Langley Research Center. For further information, Circle 96 on the TSP Request Card.

This invention is owned by NASA, and a patent application has been filed. Inquiries concerning nonexclusive or exclusive license for its commercial development should be addressed to the Patent Counsel, Langley Research Center [see page 21]. Refer to LAR-13286.

Clip-On Extensometer

A flexural clamp eliminates problems of operator variability.

Lyndon B. Johnson Space Center, Houston, Texas

A clip-on extensometer developed for testing Space Shuttle insulation tiles accurately measures length changes of loaded specimens. The new design reduces measurement errors caused by variability among test operators.

The extensometer is intended for use on ceramic, metal, or polymeric specimens (see figure). It consists of three flexural units. The central unit serves as a spacer, and the outer two units clamp on the specimen.

The operator attaches the extensometer to a specimen by squeezing together two screws on the central flexure unit. This moves the outer units apart so that the extensometer can be slipped over the specimen. When the operator releases the

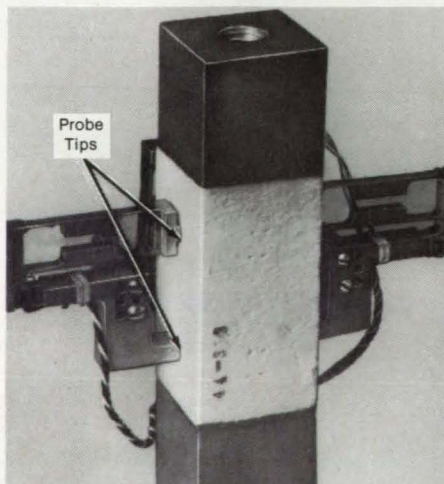

VIEW FROM FRONT OF BLOCK SPECIMEN

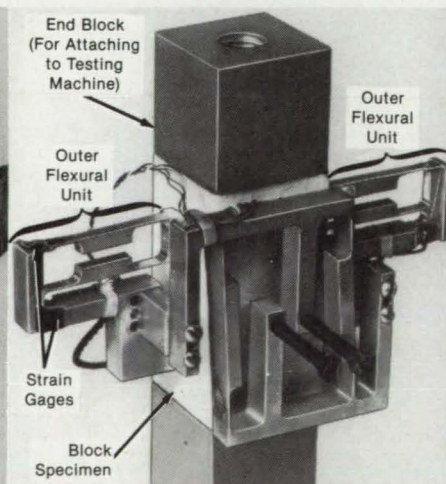

VIEW FROM REAR OF BLOCK SPECIMEN

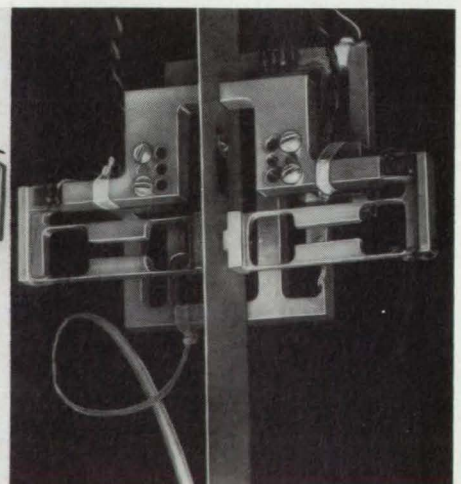

EXTENSOMETER CLIPPED TO STRIP SPECIMEN

The **Extensometer Opens and Closes Like a Clothespin** and can thus be placed easily on a specimen. The dimensions of the block specimen are 1 by 1 by 2.2 inches (2.54 by 2.54 by 5.59 centimeters). By constructing central flexure units of various widths, one can adapt the extensometer to handle specimens ranging from thin strips to those many inches thick.

screws, the outer units move toward each other, pressing on the specimen sides with a force of 1.2 pounds (5.3 N). Each outer unit contacts the specimen with two small probe tips on flexing arms that are instrumented with strain gages.

As a tensile or compressive load is applied to the specimen, the corresponding change in specimen length is transmitted to the strain gages. Each gage is previously calibrated separately, and an appropriate

amount of resistance is added to the gage producing the highest output; each gage thus ends up with the same sensitivity. The two outputs are summed to give an average strain value.

Previously, a strain-gage fixture had to be installed on the specimen by alternately tightening the screws in each of a pair of plates to embed sensing tips. The amount of tightening varied among operators and created uncertainty about the distance be-

tween the tip and the strain gage. Now, with the clothespin extensometer, strain measurements are repeatable within 1 percent for a test-machine stroke of 0.005 in. (0.127 mm).

This work was done by Alan M. C. Holmes and Michael C. Duggan of Lockheed Missiles & Space Co., Inc., for Johnson Space Center. For further information, Circle 21 on the TSP Request Card. MSC-20710

Precise-Conductance Valve Insert

A valve modification provides two operating modes: fully open and small, precise leak.

Langley Research Center, Hampton, Virginia

Numerous applications in surface physics, vacuum physics, materials science, gas kinetics, thin films, and other areas of research require measured flows of gas into or out of systems. This is generally accomplished by use of the calibrated leaks, permeation membranes, or small precision apertures. All of these techniques involve paths of small or virtually zero conductance, but it is often desirable to be able to increase the conductance back to some large level for such other system operations as purging or bakeout of the upstream region. In the past, these fixed conductances were just accepted limitations of the systems, and it was necessary to include alternate high-conductance paths with additional valves, couplings, gaging, and other expensive vacuum hardware.

By replacement of the ordinary copper valve seat in a commercial all-metal-seal, right-angle valve with an inexpensive insert, a high conductance becomes available in the fully open position, which facilitates ultra-high vacuum (UHV) cleanup or other system operations. In the closed position, this insert permits a calculable small conductance to provide a metered flow rate into one of the two regions separated by the valve. The figure shows the insert mounted in a 1.375-in. (34.92-mm) inside-diameter, commercially-available right-angle valve in the open configuration.

The insert is thicker than an ordinary valve seat and is bored out to a diameter of 0.75 in. (19.05 mm) with 10 evenly spaced and radially oriented holes of 0.187-in. (4.75-mm) diameter and 0.2385-in. (6.06-mm) length. The conductance of the small aperture at the apex of the machined cone is 0.088 l/s (N_2), which is at least 100 times smaller than the valve conductance on either side,

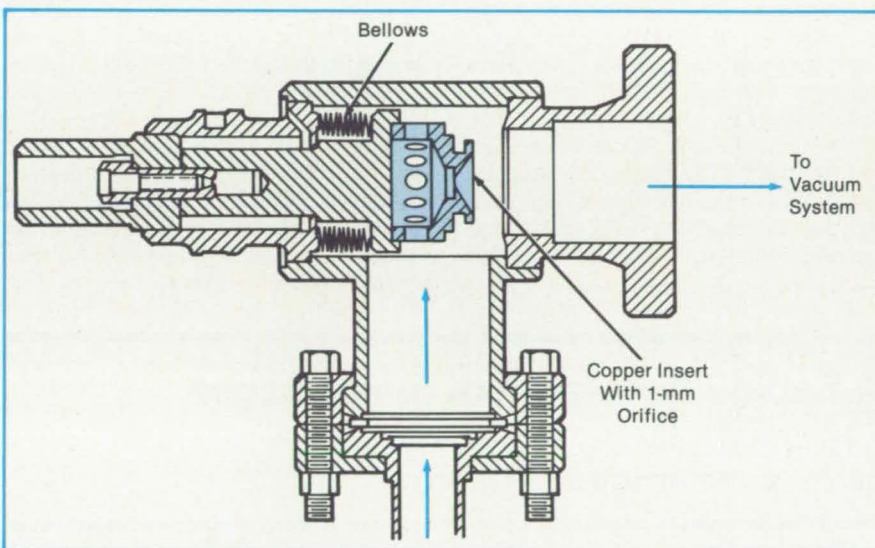

The **Copper Insert With Radially Oriented Holes** allows a small, controllable, precise effusion rate when the valve is closed or nearly unobstructed flow when the valve is open.

thus giving a precise effusion rate for a given upstream pressure.

The cone can be machined in either direction to establish desired effusion conditions. Different conductances can be effected by controlling the size of this aperture; a range from 10^{-4} to 1 l/s for this size valve is possible. The upper limit for larger valves is approximately 40 l/s.

These inserts can also be made into permeation membranes of palladium or silver for metered flows of H_2 and O_2 , respectively. The conductance of the valve illustrated in the open position is approximately 25 l/s (N_2), which is sufficient for normal operation. When the valve is closed, the conductance is reduced to a precise 0.088 l/s (N_2). The lifetime of the device is essentially the same as for the normal copper seat (>50 closures).

The insert is easily machinable and

can be inserted into an existing commercial all-metal-seal UHV valve in place of the standard seat. The desired conductance may be obtained by machining or by using a membrane to provide a calculable flux from permeation. In the fully open position, valve flow and system operation are normal for that valve. In the closed position, the valve flow becomes a precision leak. This device has been successfully proved over several years in a wide range of applications, including secondary standards, gage-calibration-orifice systems, gas-adsorption devices, and other experimental systems.

This work was done by Ronald A. Outlaw and Ronald F. Hoyt of Langley Research Center. For further information, Circle 86 on the TSP Request Card. LAR-13340

Detecting Cavitation Pitting Without Disassembly

A new method is based on isotope generation in the inspected part.

Marshall Space Flight Center, Alabama

A technique for detecting cavitation pitting in pumps, turbines, and other machinery uses low-level nuclear irradiation. It is important to detect cavitation pits because a nozzle, turbine blade, or other pump component weakened by cavitation could fail catastrophically and cause the machine to explode.

Until now, such pitting could be detected only by disassembling the machine and checking parts visually for damage. This procedure is costly in time and labor.

In the new method, the surface to be inspected is irradiated with protons or alpha particles from small particle-beam accelerators in such a way that most of the isotopes generated by the particle beam are concentrated inside the part, within a few thousandths of an inch (within about 0.05 mm) of the surface. Though the radiation is applied from within the machine housing, the residual low-energy gamma radiation from the part is measured from outside the housing. To obtain the spatial resolution

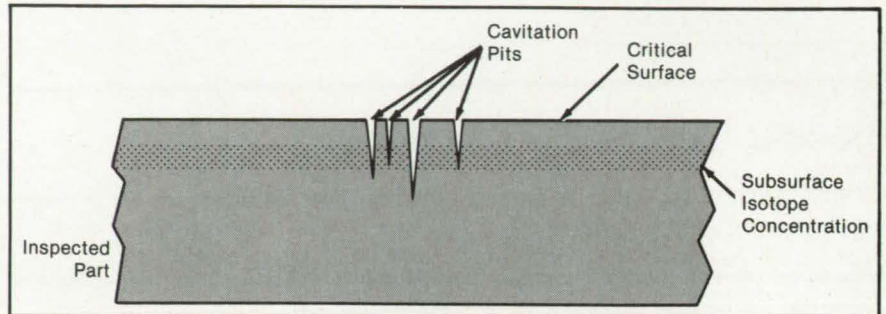

Isotopes Concentrated Below the Surface emit gamma radiation, a portion of which is attenuated by the overlying material. Where there are cavitation pits, the output of a gamma-ray detector fluctuates as the detector is scanned near the pits.

needed to detect the pits, lead or tungsten shielding is placed around the detector line of sight.

If only slight surface erosion has occurred, no significant change in radiation level is measured. However, if cavitation has created sharp pits (see figure), the radiation level fluctuates significantly while scanning

the gamma detector near the pits. Maintenance people can then be alerted to change the part.

This work was done by S. Barkhoudarian of Rockwell International Corp. for Marshall Space Flight Center. No further documentation is available. MFS-19902

A Rapid Attachment of Strain Gages

A hand-held toroidal gun concentrates heat in a localized area.

Langley Research Center, Hampton, Virginia

A new method for bonding film gages (e.g., strain gages) eliminates time-consuming oven curing. A hand-held "gun," (see figure) operates on induction heating to concentrate heat in a localized area. A ferritic plate is added for low-reluctance or no-reluctance surfaces.

The method reduces adhesive cure time from hours to minutes. It is primarily applicable to the bonding of strain gages at about 204° C. If the surface is a ferritic material such as 410 stainless steel, sufficient heat to cure an adhesive is generated within the steel because of reluctance and poor thermal conductivity. If the bonding surface is nonferritic, however, a ferritic material in the form of a thin plate [1/8 in. (3.2 mm)] with a thin rubber pad is placed between the specimen and the energy source. Adequate heat is conducted and radiated from the ferritic plate

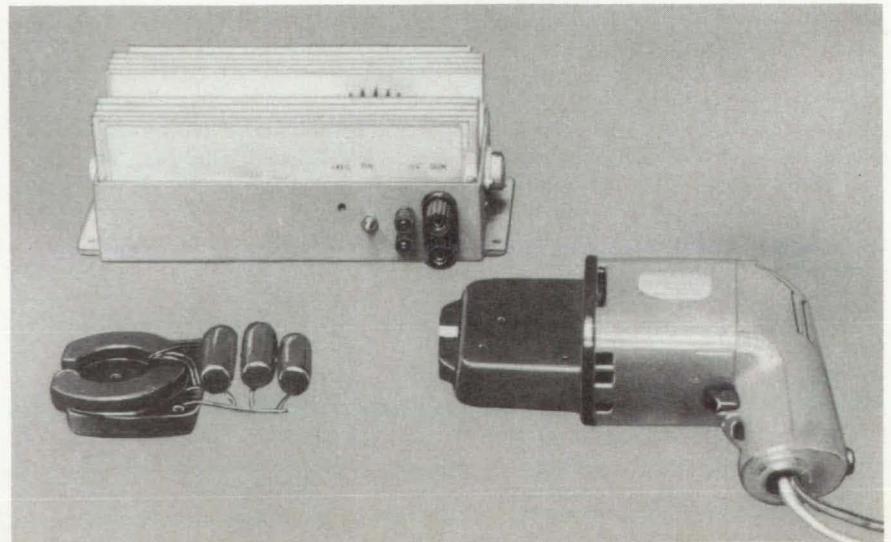

The **Toroidal Gun** eliminates time-consuming oven cure when bonding strain gages.

to cure a bonding adhesive. In bonding a film gage, the gun is placed on the gage with approximately 5 pounds of pressure per square inch ($3.4 \times 10^4 \text{ N/m}^2$) and energized for 2 minutes. Pressure is maintained for an additional minute during cooldown.

The lightweight, portable gun is a fast, low-power device. Bonding results indi-

cate that, by heating the surface material itself, no internal heating of the strain-gage grid (which may cause strain-gage damage) takes place during bonding.

This work was done by Timothy D. Schott, Robert L. Fox, and John D. Buckley of **Langley Research Center**. For further information, Circle 11 on the TSP Request Card.

This invention is owned by NASA, and a patent application has been filed. Inquiries concerning nonexclusive or exclusive license for its commercial development should be addressed to the Patent Counsel, Langley Research Center [see page 21]. Refer to LAR-13237.

Easily Accessible Camera Mount

The mount reduces installation time and holds the cameras more securely.

*John F. Kennedy Space Center,
Florida*

A modified mount enables fast alignment of movie cameras in explosionproof housings. The previous mount had a knurled, slotted head screw at its aft end. When a camera was mounted, there was little room between the camera and the housing for the installer's fingers to tighten the screw to secure the camera. Often, the camera would come loose from vibrations and produce blurred images.

With the modified mount, the screw is on the side and is readily reached through the side door of the housing (see figure). The mount includes a right-angle drive mechanism containing two miter gears that turn a threaded shaft. The shaft drives a movable dovetail clamping jaw that engages the fixed dovetail plate on the camera. The mechanism thus aligns the camera in the housing and secures it.

The mechanism reduces installation time by 80 percent. The time saved is significant when many cameras are set up to record an event.

This work was done by Howard E. Chalson of PRC Systems Services for **Kennedy Space Center**. For further information, Circle 47 on the TSP Request Card.
KSC-11316

A Camera-Securing Screw is easily reached through the side door of an explosionproof housing. Formerly, the screw was in the hard-to-reach rear of the mount.

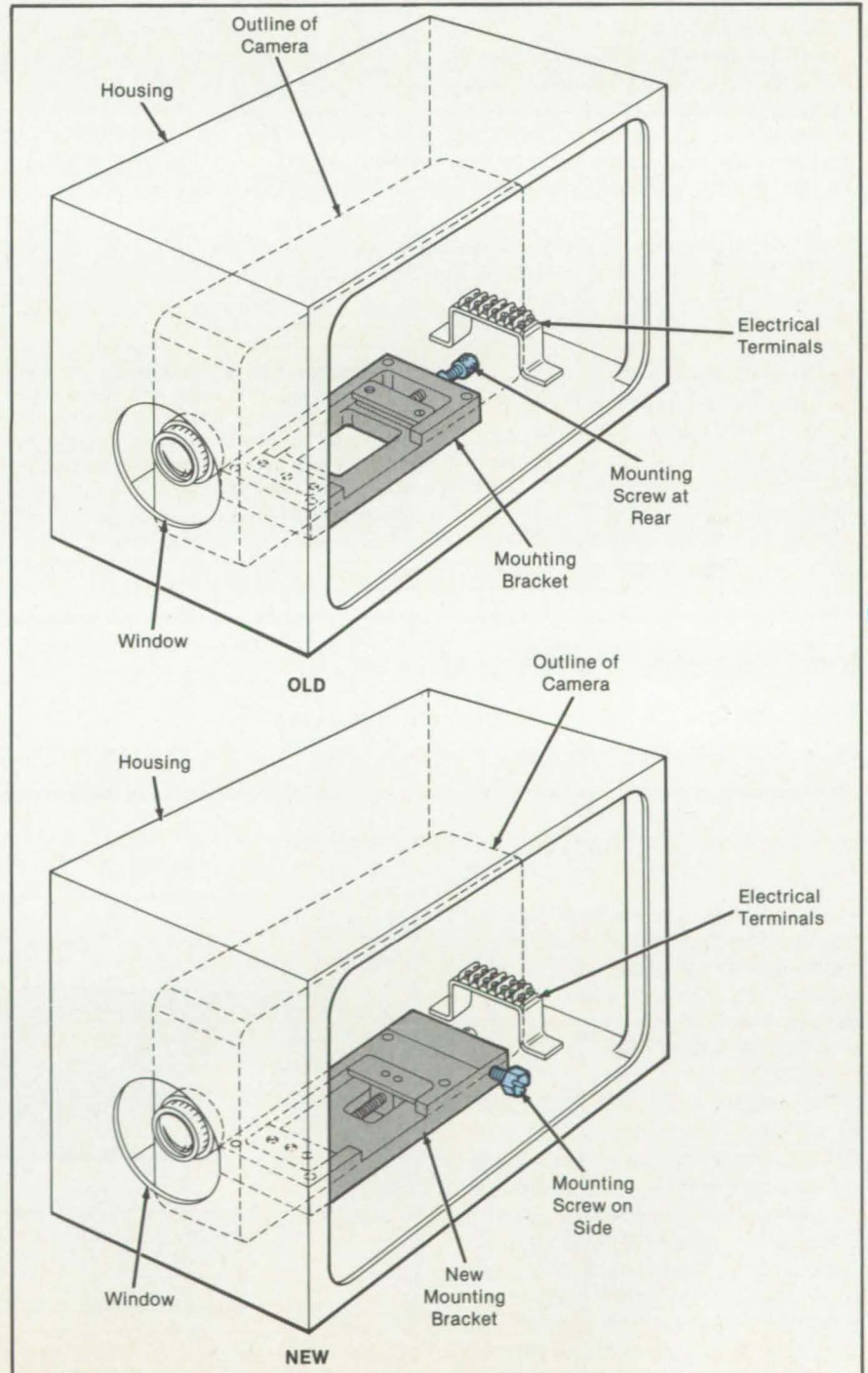

Graphical Method for Predicting Steady-State Temperature

The temperature that a heated or cooled passive system will reach is predicted from temperature-versus-time curves.

Lyndon B. Johnson Space Center, Houston, Texas

A simple graphical construction method, originally developed for Space Shuttle applications, predicts the equilibrium temperature of a system that is being heated or cooled. The method assumes that the temperature relaxes exponentially toward an equilibrium value. The results can be obtained in minutes without a computer or complex calculations.

A plot of the early temperature-versus-time history of the system must first be determined by measurement for a given set of constant thermal conditions. From this plot, the ultimate steady-state temperature that the system will attain can be constructed. The construction method for a system being heated is as follows:

- A tangent is drawn to the temperature-versus-time curve at the point at which heating or cooling starts (line 1 in the figure).
- A second tangent is drawn to the curve at any point θ_2, T_2 (line 2 in the figure). Line 2 must have a slope different from that of line 1.
- Line 3 is drawn parallel to line 2 through temperature T_2 on the vertical axis. The temperature T_s at the intersection of lines 1 and 2 is the steady-state temperature.

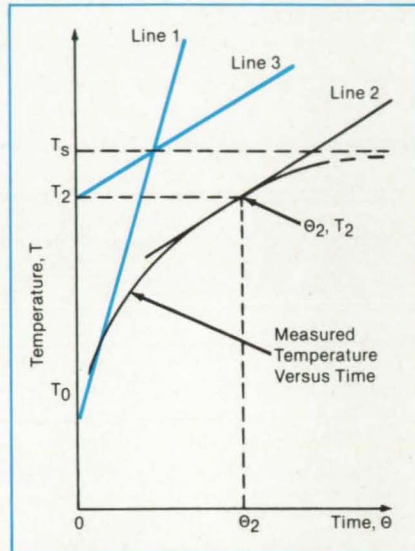

The **Intersection of Two Lines** in a graphical construction gives the asymptotic temperature of a system. Developed for analyzing thermal anomalies during flights of the Space Shuttle, the graphical method is also applicable to everyday heating and cooling problems.

The procedure for a system being cooled is identical except that the slopes are negative.

The time θ_s for the system to progress through 99 percent of the temperature difference between the initial and steady-state values is computed from the equation

$$\theta_s = [(T_s - T_0)/(\text{slope of line 1})] \times \ln(100)$$

where T_0 is the temperature of the system at time zero. The 99-percent point is used as a convenient approximation, since theoretically it would take an infinitely long time to reach the final temperature.

The method is applicable to a variety of problems. Examples include the temperatures of buildings, powerplant or refinery components, or chemical reactors; voltages on charging or discharging capacitors; and concentrations of reactants in some chemical processes.

This work was done by Robert L. Case, Jr., of Rockwell International Corp. for Johnson Space Center. For further information, Circle 36 on the TSP Request Card. MSC-20835

Ice Detector for Aircraft

The thickness of ice on aircraft is measured by a flush-mounted sensor.

Langley Research Center, Hampton, Virginia

A new three-gage device detects and measures the thickness of ice accumulation on the outside of aircraft. This information is required to determine whether efforts to remove the ice, such as heating or a change in flight speed or elevation, should be initiated.

The detector consists of the following: (a) a flush-mounted sensor with three separate components as shown in the figure; (b) a temperature-measuring circuit, the configuration of which is based on the type of sensor used (e.g., resistance film, thermocouple, integrated-circuit temperature sensor); (c) two capacitance-measuring circuits; and (d) a logic circuit that uses the outputs of the other three circuits to determine the presence of ice

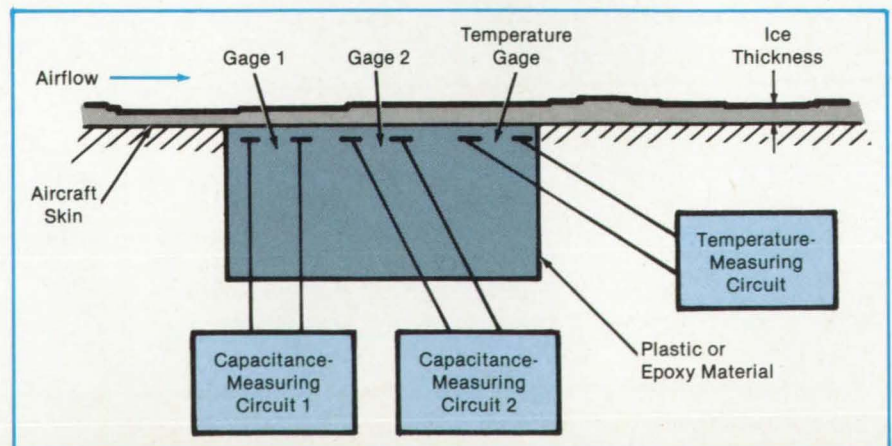

The **Capacitance Gages** sense water or ice and measure the thickness. The temperature gage helps to distinguish between water and ice.

and its thickness.

Most solid insulating materials such as plastic or epoxy have dielectric constants of 3 to 5. Pure water and ice have dielectric constants near 80. If two conductors are embedded near the surface of such an insulator and a layer of pure water covers the surface, the capacitance between the two conductors is strongly influenced by the proximity of the high dielectric constant of water or ice.

Gage 1, with small conductors and a small gap, gives a large change in signal for a very small water thickness, with only slight differences for pure or conductive

water. This gage detects water and ice. The temperature gage senses whether the skin is above or below freezing, thus differentiating between water and ice. The output signal for gage 2, which has a larger gap than gage 1, varies slowly with thickness and is nearly linear up to a fairly large thickness. Thus, gage 2 measures the thickness of the ice.

The logic circuit uses the temperature circuit to differentiate between water and ice. A comparator for capacitance-measuring circuit 1 detects whether any significant amounts of water or ice are present. The output of capacitance-

measuring circuit 2 yields a certain level. Thus, this combination of circuits of the flush-mounted sensor allows the detection of water or ice and the measurement of the ice thickness on the outside of the aircraft skin.

This work was done by Leonard M. Weinstein of Langley Research Center. No further documentation available.

Inquiries concerning rights for the commercial use of this invention should be addressed to the Patent Counsel, Langley Research Center [see page 21]. Refer to LAR-13403.

High-Performance Heat Pipe With Screen Mesh

Liquid is distributed more evenly in the evaporator section.

Lyndon B. Johnson Space Center, Houston, Texas

A rolled-screen insert increases the capacity of the heat pipe described in "High-Performance Heat Pipe" (MSC-20136), page 70, *NASA Tech Briefs*, Vol. 9, No. 2, (Summer 1985). The insert reduces the incidence of dryout at hotspots or during intervals of general thermal overload.

The insert is an artery and bridging wick formed from stainless-steel screen (see figure). The artery is centered in the liquid channel of the heat pipe but separated from the liquid-channel wall to reduce heat transfer from the wall into the artery. The bridging wick passes through the capillary channel between the liquid and vapor channels and makes contact with the wall of the vapor channel on the far side.

When the local or temporary heat transfer to the evaporator is high enough to boil all or part of the liquid away from the evaporator walls, the artery still contains liquid. The vapor in the annular-cross-sectional space between the liquid channel and the artery acts as a partial thermal insulator, thereby protecting the liquid in the artery from immediate boiling. The artery thus continues to distribute liquid to the parts of the evaporator that are not overheated, and the evaporator is protected against dryout and the consequent loss of heat-transfer capacity.

The bridging wick provides an auxiliary path for liquid to flow from the artery to the capillary slot and to the capillary grooves in the wall of the vapor channel. By feeding the liquid directly to the primary heat-input zone opposite the capillary channel, it helps to spread the liquid evenly onto the walls of the vapor channel, thereby further reducing the tendency toward dryout.

A porous plug made of four layers of the screen material allows liquid to pass but

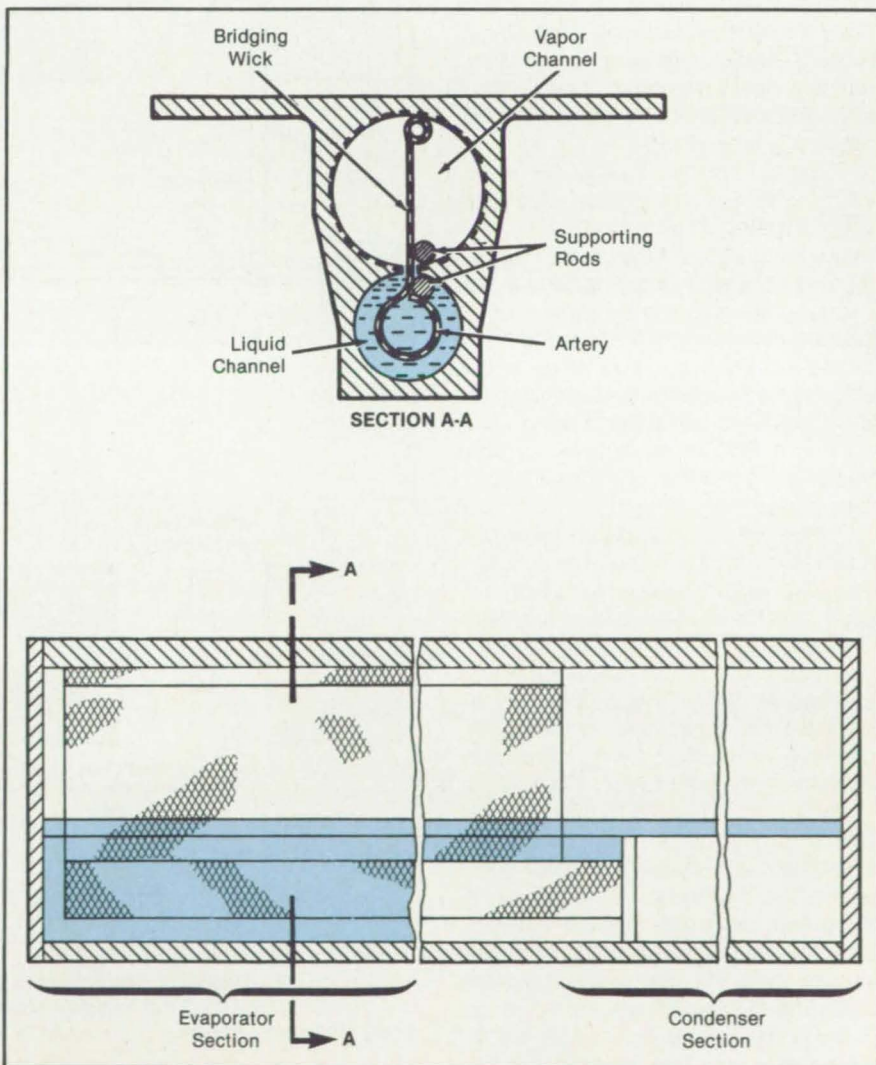

The Improved Heat Pipe contains an artery and wick rolled from stainless-steel screen of 180 mesh (openings about 80 μm). The screen material helps to prevent dryout in the evaporator section by conducting liquid through hotspots and to the vapor-channel wall.



keeps the vapor that originated at hotspots from forcing liquid out of the condenser section of the liquid channel. The plug also helps to suppress flow instabilities arising from fluctuations of the vapor pressure.

This work was done by Joseph P. Alario,

Richard F. Brown, and Robert Kosson of Grumman Aerospace Corp. for **Johnson Space Center**. For further information, Circle 32 on the TSP Request Card.

This invention is owned by NASA, and a patent application has been filed. Inquiries

concerning nonexclusive or exclusive license for its commercial development should be addressed to the Patent Counsel, Johnson Space Center [see page 21]. Refer to MSC-20497.

Measuring Gearbox Torque Loss

Accuracy is increased by measuring small torque differences directly.

NASA's Jet Propulsion Laboratory, Pasadena, California

A proposed apparatus would measure the portion of the input torque lost to friction in an automotive transmission or other gearbox. The apparatus, which would measure the difference between the input and gear-ratio-compensated output torques, would be more sensitive than previous measuring systems. Previously, the relatively large input and output torques were measured separately, mathematically corrected for the gear ratio, and subtracted — a procedure susceptible to large errors.

The motor and the absorber are free to rotate, while the transmission under test is fixed against rotation (see figure). The torque exerted by the motor on the transmission input shaft is reacted and transmitted by the motor torque arm to the left balance arm. Similarly, the torque exerted by the transmission output shaft on the absorber is reacted and transmitted by the absorber torque arm to the right balance arm. Both balance arms are connected to each other at a joint linked to load cell.

The left balance arm is constrained by a fixed pivot at its midpoint. The right balance arm is constrained by a pivot at a point selected so that the lever-arm ratio compensates for the torque multiplication in the gearbox: The ratio L_1/L_2 equals the inverse of the theoretical torque-multiplication (gear) ratio. In the fourth-gear position shown, $L_1 = L_2$ because in fourth gear, the gear ratio is 1 to 1.

The forces delivered by the balance arms to the load cell are thus proportional to the input and gear-ratio-compensated output torques, respectively. But since these two forces are opposite in direction, they subtract, and the load cell senses only the difference between them. The difference is a direct indication of the portion of the input torque lost in the transmission. The power loss is obtained by multiplying the input-torque loss by the input angular shaft speed.

This work was done by Louis F.

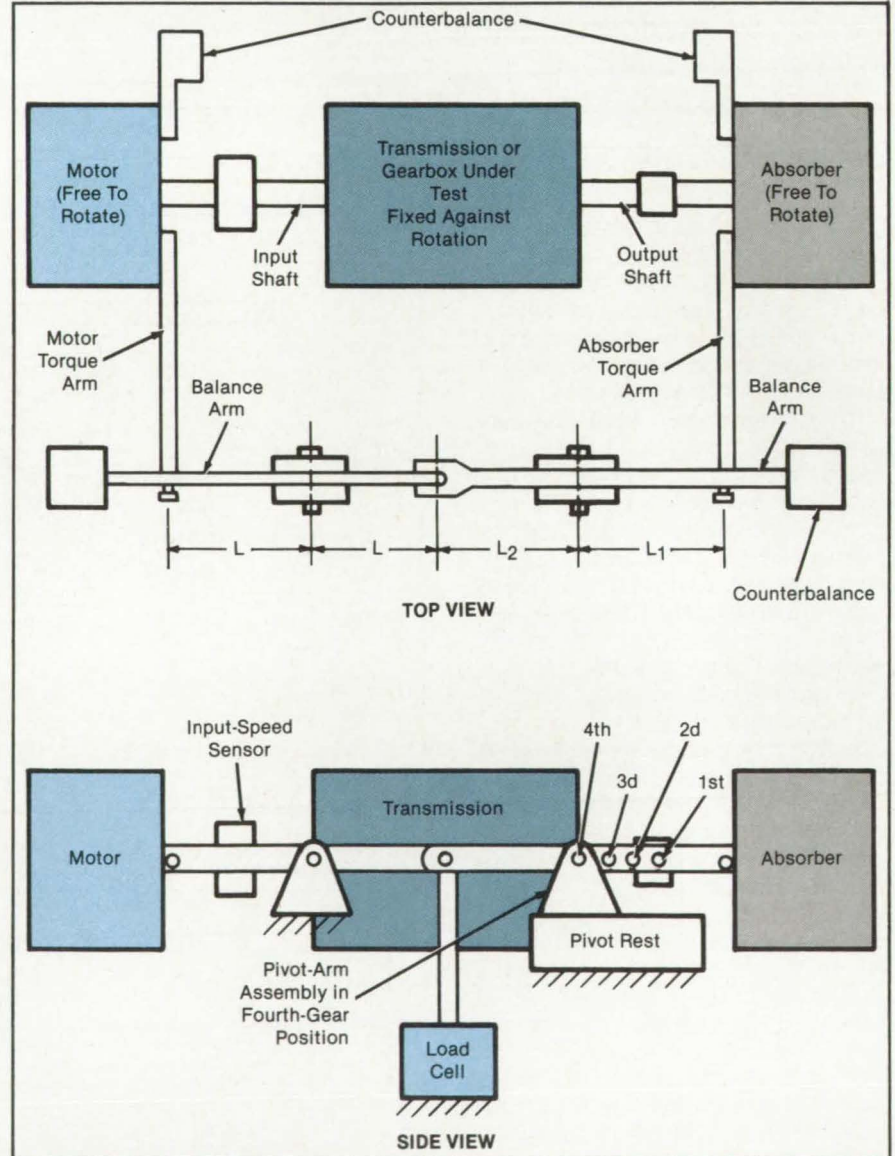

Input and Output Torques Are Balanced by a mechanical linkage in this transmission-testing apparatus. The force applied to the load cell is proportional to the frictional torque loss in the transmission.

Schmidt of Caltech for **NASA's Jet Propulsion Laboratory**. For further informa-

tion, Circle 90 on the TSP Request Card. NPO-15794

NASA Tech Briefs, January/February 1986

Measuring Heat-Exchanger Water Leakage

Water-leakage rate can be measured directly.

Lyndon B. Johnson Space Center, Houston, Texas

Water leakage in a heat exchanger is measured directly with the help of an electrolytic hygrometer. The new measurement method determines water concentrations of up to 2,000 parts per million with an accuracy of ± 5 percent.

Up to now, leakage has usually been measured by pressurizing the exchanger with gaseous helium and determining the helium leakage rate with a mass spectrometer. Converting the helium leakage to an equivalent water leakage is subject to considerable inaccuracy, however.

In the new technique, a flow of nitrogen gas is set up in one loop of the heat exchanger (see figure). The other loop is filled with water under pressure. The water concentration produced by leakage of the water into the nitrogen flow is measured by the hygrometer.

With pressure regulator PR₁, the flow of nitrogen in loop A of the exchanger is set at 20 standard ft³/h (0.57 standard m³/h), as indicated by flowmeter FR₁. With valve V₂, a back pressure of 10 to 15 psig (69 to 103 kPa gage) is established at gage G₁ in loop A. After the system stabilizes (in about 30 min), a reading of background water concentration is made with the hygrometer. This is the water vapor concentration that prevails without leakage.

Next, loop B is evacuated, filled with distilled water, and pressurized with nitrogen. Regulator PR₂ is adjusted so that the requisite pressure difference exists between the

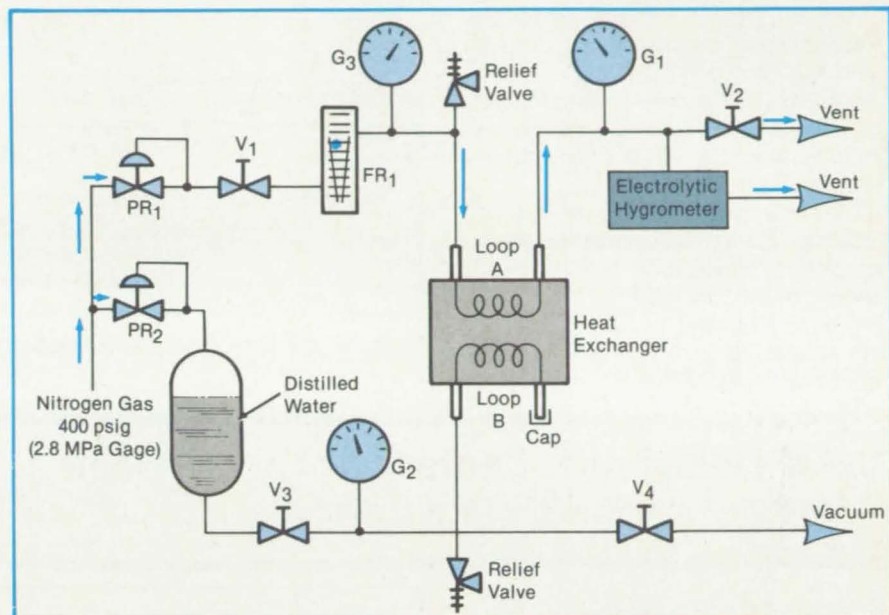

Pressure Regulators, Valves, Flowmeters, and Gages allow control of conditions for the accurate measurement of water leakage in a heat exchanger. The concentration of water vapor created in loop A by leakage from loop B is measured and converted to a leakage rate.

loops. The reading on gage G₂ will then be equal to the value on gage G₁ plus the pressure difference. After stabilization, the hygrometer is again read. Its indicated value less the background value represents the concentration caused by leakage. From this concentration, the known pressures, and the nitrogen flow rate, the leakage rate

is then calculated in any convenient units such as cubic centimeters per hour.

This work was done by John Zampiceni of United Technologies Corp. for Johnson Space Center. For further information, Circle 24 on the TSP Request Card. MSC-20811



Optimized Bolted Joint

Computer technique aids in joint optimization.

Langley Research Center, Hampton, Virginia

Load-sharing between fasteners in multirow bolted composite joints was computed by a nonlinear-analysis computer program. Input to the analysis was load-deflection data from 180 specimens tested as part of a program to develop the technology of structural joints for advanced transport aircraft.

The program predicted strengths of 20 large subcomponents representing strips from a wing-root chordwise splice. In most NASA Tech Briefs, January/February 1986

cases, the predictions were accurate to within a few percent of the test results. The highlight of the subcomponent testing was the consistent ability to predict gross section failure strains close to 0.005. This represents a considerable improvement over state-of-the-art values of 0.003 to 0.004.

The computer program was used to analyze and compare multirow joints of different concepts, as shown in the figure. The configuration consisting of tapered

splice plates in combination with a uniform skin thickness (configuration D) was predicted to be the most efficient joint design. The design was optimized by a sequence of iterations that minimized the bearing load and maximized the bypass load at the first row of fasteners while maximizing the load at the last (innermost) row of fasteners. The other configurations shown, which were less efficient, did not exhibit the progressive distribution of load in succeeding bolt

rows.

The bolt design optimization technique is applicable to major joints in composite materials for primary and secondary structures and should be generally applicable for metal joints as well. The technique allows optimizing manipulations of joint configuration in order to produce highest possible strain and load transfer for a given load situation.

This work was done by L. J. Hart-Smith, B. L. Bunin and D. J. Watts of McDonnell Douglas Corp. for Langley Research Center. Further information may be found in NASA CR-3710 [83X-10287], "Critical Joints in Large Composite Aircraft Structure." A copy may be purchased [prepayment required] from NASA's Industrial Applications Centers listed on page 21.

This invention is owned by NASA, and a patent application has been filed. Inquiries concerning nonexclusive or exclusive license for its commercial development should be addressed to the Patent Counsel, Langley Research Center [see page 21]. Refer to LAR-13250.

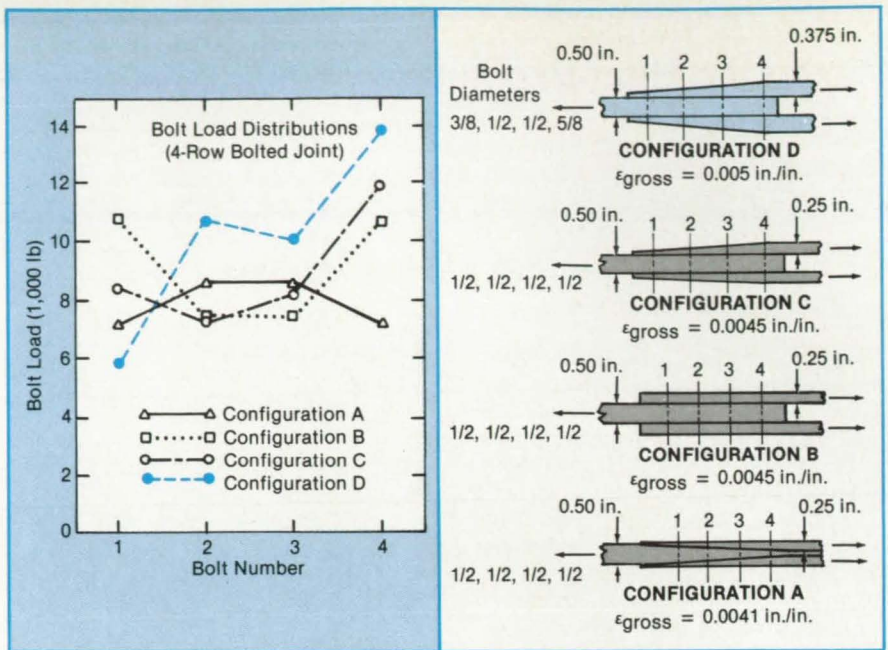

The Effect of Joint Configuration on Bolt Load Distribution is shown for four designs.

Laser Holder Aids Centering of X-Ray Head

Alignment is made easier, safer, and more reliable.

Marshall Space Flight Center,
Alabama

A laser holder used when aligning an X-ray head makes the procedure safer and more reliable. Previously, X-ray heads used to inspect production welds had been aimed with the help of lasers attached by hose clamps. However, the clamps often slipped and caused misalignment. The lasers also hindered the placement of the heads, and the laser power cords were cumbersome. The new holder grips the laser securely, maintains alignment, does not interfere with head placement, and requires only one 110-V power cord.

The holder includes an open, boxlike clamp in which the laser is mounted on a movable lower plate (see Figure 1). A stationary upper plate is attached by bolts to the aluminum X-ray tubehead. The plates and clamp are made of aluminum. The clamp walls are attached to the lower plate with fillet welds.

The upper and lower plates are hinged together at one edge (see Figure 2). Near the opposite edge is a small force-

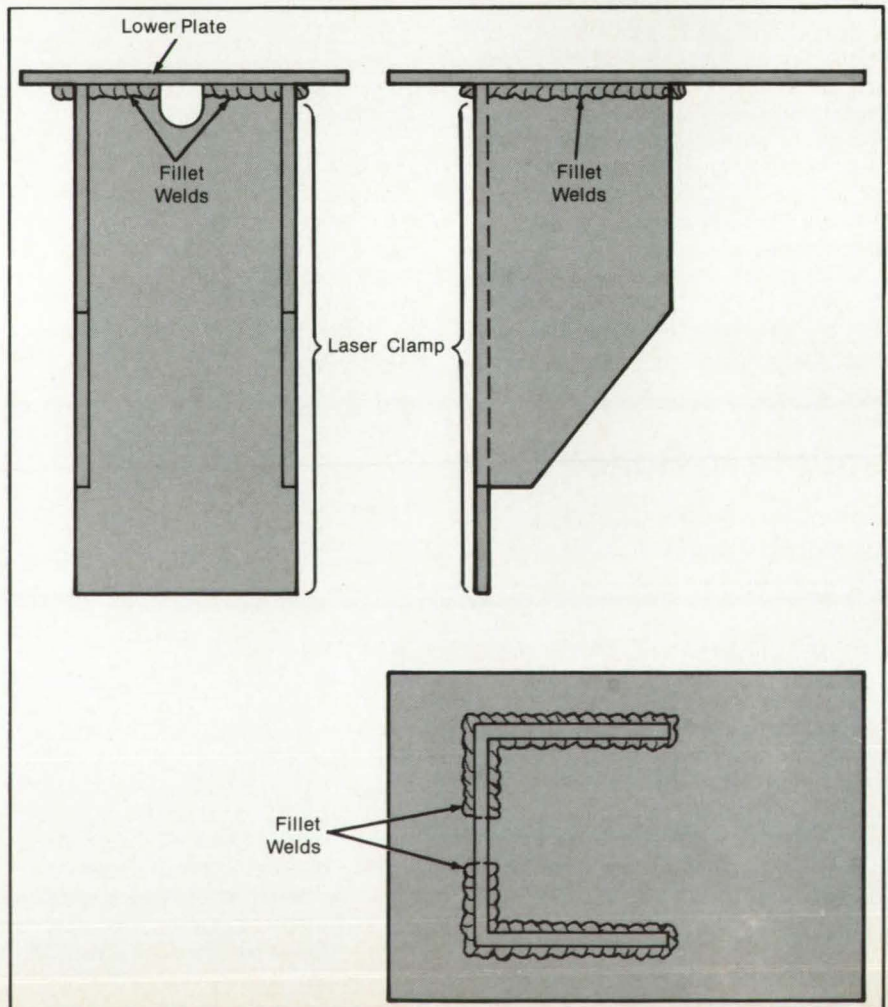
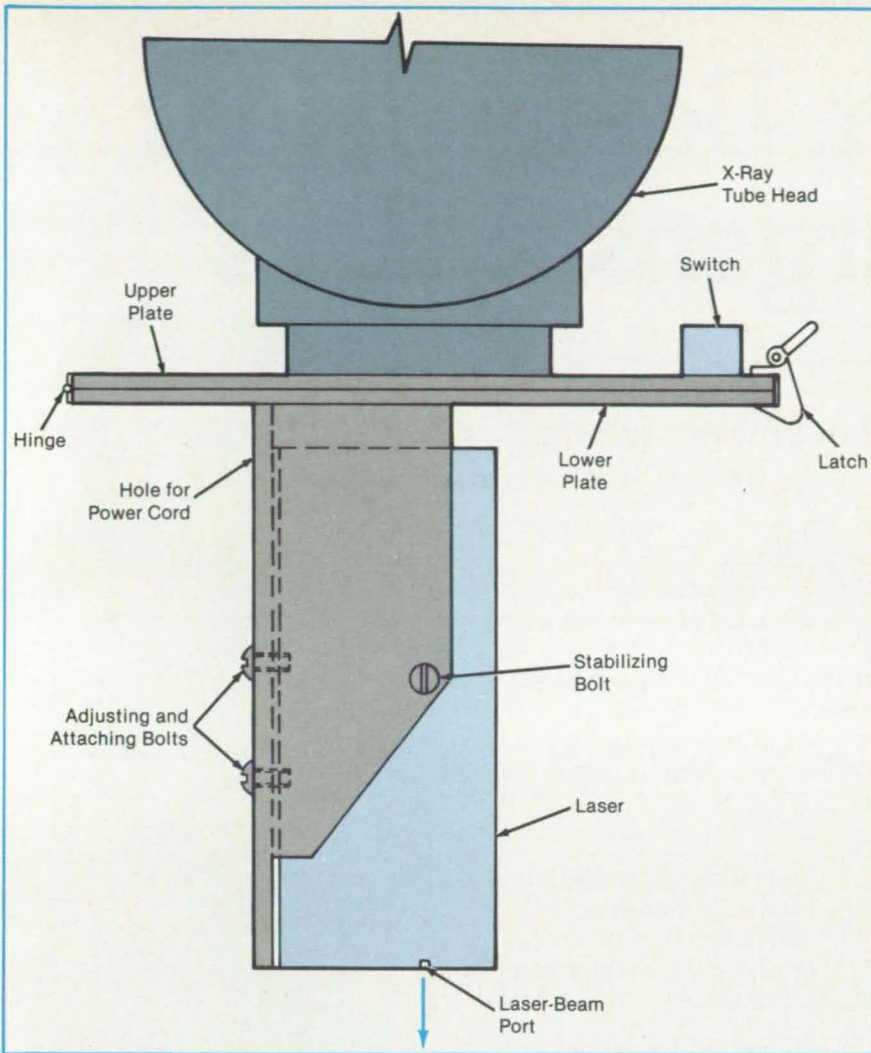

Figure 1. The Lower Plate and Laser Clamp are made of aluminum pieces welded together.



actuated power switch that closes when the plates swing together. A spring-loaded latch at the edge near the switch enables the two plates to be clamped together to secure the laser in the operating position.

When the laser is mounted on the bottom plate, it is aligned with adjusting/attaching bolts so that the laser beam coincides with the X-ray beam axis. The laser is then immobilized relatively to the clamp by stabilizing bolts through the clamp walls.

To begin alinement of the X-ray head, the laser is swung into the operating position with the plates latched together. The laser beam is aimed at the designated spot on the part to be photographed by X-rays. The latch is then opened and the laser swung out of the way. The switch opens, turning the laser off. The laser is held out of the X-ray path while the part is exposed.

This work was done by D. V. Bulthuis and D. D. Kettering of Rockwell International Corp. for Marshall Space Flight Center. No further documentation is available.
MFS-29067

Figure 2. The **Laser Holder Assembly** is attached to an X-ray head to enable the head to be aligned optically before X-ray exposure. When the laser is in the operating position as shown here, the laser beam shines on the spot that will later be illuminated with X-rays.

Higher Sensitivity in X-Ray Photography

Hidden defects are revealed if the X-ray energy is decreased as the exposure progresses.

Marshall Space Flight Center, Alabama

Declining-potential X-ray photography has been used to detect fractures in a thin metal sheet covered by an unbroken sheet of twice the thickness. Originally developed to check solder connections on multi-layer circuit boards, the technique has potential for other nondestructive testing.

A typical test setup is shown in the figure. As the film is exposed, the voltage applied to the X-ray tube is decreased. The declining potential results in a corresponding decline in the maximum X-ray energy and a corresponding decrease in the penetrating power of the X-rays.

At some point during the exposure, the penetrating power reaches a threshold below which the radiation passing through the total material thickness is insufficient to appreciably affect the film. However, since NASA Tech Briefs, January/February 1986

The **Setup for Declining-Potential X-ray Photography** is shown above. The photograph below was taken using ASA 400 film with exposures of 10 s at 60 kV followed by 5 s at 30 kV. It reveals a hidden fracture in an aluminum sheet only 19 mils (0.48 mm) thick, covered by an unfractured sheet 38 mils (0.97 mm) thick.

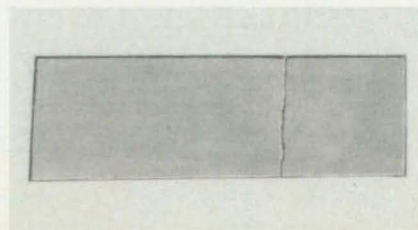

the defect region is thinner than the rest of the material, it has a lower penetration threshold, and enough radiation passes

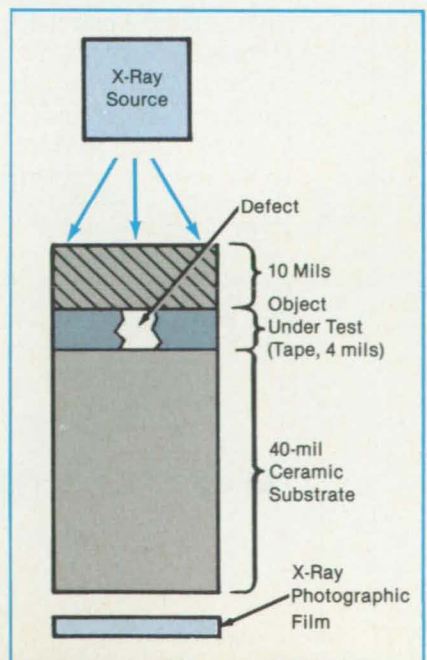

Amer, Bozich, Hess, Juergens & Ross

These are the kind of Fellows who are making the world we'll live in tomorrow.

These are five top achievers in technology—newly named McDonnell Douglas Engineering and Research Fellows.

Our company searches out and develops men and women who are creative leaders in their work. We surround them with challenges to be met. We provide them with the facilities to fulfill their potential and with opportunities for advancement in the fields in which they do their best work.

Amer, Bozich, Hess, Juergens and Ross bring progress and honor to our company. They represent in the world of technology what the Albin Polasek sculpture shown here represents in art: Mankind carving its own destiny.



Kenneth B. Amer has gained industry-wide recognition for his substantial contributions to rotary-wing aeronautics. With his remarkable grasp of all technical aspects of helicopter design and testing, he was a key team member in the development of the OH-6A and AH-64 helicopters.

Dr. William F. Bozich has applied his expertise to the investigation of laser vulnerability, lethality, and hardening of missiles and aircraft to laser radiation. Two of his laser hardening design concepts are currently under development in SDI research programs.

John L. Hess is an aerodynamics engineer whose nearly 30 years' work with air flow and acoustics radiation problems has led to worldwide textbook standards for aircraft

design. His test methods are used daily throughout industry and have influenced the design of all of our own commercial jet transports.

Raymond J. Juergens has brought exceptional talent and ingenuity to the advancement of composite materials technology. His knowledge and experience in non-metallics has been a significant factor in the success of our company's F-15, F/A-18, and AV-8B aircraft.

Monte Ross has pioneered in the development of space laser communications. Research and development launched under his leadership led to the first lasercom equipment to be space qualified, and has brought important advances in laser communications to submarines.

"Man Carving Out His Destiny"

MCDONNELL DOUGLAS



The Roster of Fellows

Amer, Bozich, Hess, Juergens and Ross join these previously named top achievers in technology, listed here with their special areas of expertise:

Eugene C. Adam. Aircraft crew station design and information display.

Dr. Norman R. Byrd. Materials science.

Dr. Tuncer Cebeci. Computational fluid mechanics and theoretical aeronautics.

Paul H. Denke. Finite-element structural analysis.

Dr. William K. Douglas. Space flight medicine and acceleration physiology.

Saul Fast. Avionics, communications and solid state electronic warfare.

Dr. James I. Gimlett. Optical and electro-optical system technology.

Dr. Virgil V. Griffith. Digital electronic system architecture.

Frank Laacke. Fighter aircraft design.

James G. Laird. Radar design and analysis.

Francis D. McVey. Computer-aided engineering for aerospace system development.

John Mackey. Human interactions with technology.

Lawrence D. Perlmutter. Navigation, guidance, control, and orbital flight mechanics.

Richard A. Rawe. Fracture mechanics.

Dr. Daniel L. Rosamond. Orbital mechanics applied to spacecraft and missile guidance.

Dr. Miklos Sajben. Flow fields in inlets and ducts.

Dr. Robert J. Sunderland. Adhesive bonding, corrosion and erosion resistance.

John C. Weitekamp. Fighter aircraft, missile and spacecraft design.

Dr. Clarence J. Wolf. Environmentally induced degradation of electrical insulation.

Dr. Rainer Zuleeg. Gallium arsenide microcircuitry.

through this region to affect the film.

Thus, it is possible to obtain contrast between the defective and "good" regions even without knowing the exact threshold voltage or the exact nature of the defect. Of course, a knowledge of the properties of the object under test and the exposure parameters of previous successful X-ray photographs aids in selecting the declining-potential waveform, the film, and the other test conditions.

The technique is able to reveal a thin layer of transparent plastic tape beneath a large-scale integrated circuit with a 10-mil (0.25-mm) metal lid and a 40-mil (1-mm) ce-

ramic substrate. Its ability to reveal hidden fractures in metal sheet is indicated by the accompanying photograph. The technique may also have medical uses in the detection of bone fractures.

This work was done by Richard N. Buggle of Honeywell, Inc., for Marshall Space Flight Center. No further documentation is available.

Inquiries concerning rights for the commercial use of this invention should be addressed to the Patent Counsel, Marshall Space Flight Center [see page 21]. Refer to MFS-28026.

Computer Programs

These programs may be obtained at a very reasonable cost from COSMIC, a facility sponsored by NASA to make raw programs available to the public. For information on program price, size, and availability, circle the reference number on the TSP and COSMIC Request Card in this issue.

Simplified Ride-Comfort Program

Vibration and noise contributions to discomfort are quantified.

RIDEQUL estimates passenger ride comfort within air- and surface-transportation systems. It provides engineers with a reliable method of objectively predicting and evaluating vehicle ride quality. RIDEQUL transforms individual elements of the noise and vibration characteristics of a vehicle into subjective units and combines these units to produce a single discomfort index. This index can be used to estimate the total ride quality within a vehicle and to make comparative ride-comfort assessments between vehicles. RIDEQUL permits the routine processing and conversion of physical ride-environment data into discomfort estimates that relate directly to passenger acceptance of the environment.

RIDEQUL reflects human frequency sensitivity to vibration by applying frequency-weighting factors to each axis of vibration, thus eliminating the need to make judgments of spectral characteristics. The weightings used in RIDEQUL were obtained from subjective comfort

ratings of more than 3,000 persons exposed to controlled environments in a passenger ride-quality simulator. RIDEQUL also incorporates the effects of interior noise levels within six octave bands. A-weighted sound levels are used. An optional ride-duration correction can also be included in the analysis to account for passenger adaptation to vibration on trips of less than 2 hours.

RIDEQUL accepts vibration input for each of five axes (vertical, lateral, longitudinal, pitch, and roll). Vertical, lateral, and roll axes can be specified as having sinusoidal vibration, and any axis can have a random vibration. If random vibration is to be the basis, TIFT-formatted data of the power spectral density of the vibration over time must be entered. RIDEQUL computes the discomfort due to vibration in each axis and then sums the axial components of vibration according to specific combined-axis algorithms. This total vibration discomfort is then corrected for the trip duration if desired.

Noise-discomfort contributions are calculated for each of the six octave bands and are then combined. The corrected vibration result is added to the total noise contribution to produce a final, overall, estimated discomfort index. In addition to the overall index, the engineer can also identify the subjective discomfort values due to individual elements of the vibration and noise.

This program is written in FORTRAN 77 for interactive or batch execution and has been implemented on a CDC CYBER 170-series computer with a central-memory requirement of approximately 70K (octal) of 60-bit words. This program was developed in 1984.

This program was written by Jack D. Leatherwood of Langley Research Center and Linda M. Barker of System Development Corp. For further information, Circle 73 on the TSP Request Card. LAR-13289



Machinery

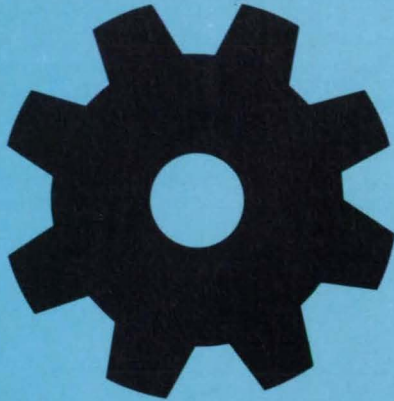

Hardware, Techniques, and Processes

- 108 Transfer Mechanisms for Heavy Loads
- 109 Multileg Heat-Pipe Evaporator
- 110 Manual "Guillotine" Wirecutter
- 110 Manifold Coal-Slurry Transport System
- 111 Heat Pipe Precools and Reheats Dehumidified Air
- 113 Jig for Removing Rivets
- 114 Detection of Machining Chips by Pressure Reversal
- 114 Digital Controller for a Remote Manipulator
- 115 Portable Hydraulic Powerpack
- 116 Oscillation Damper With Two Spring Rates
- 116 Dual-Flow-Rate Valve
- 117 Rotary Joints With Electrical Connections
- 118 Emergency Brake for Tracked Vehicles
- 119 "Curtainless" Window
- 120 Secure Disposal Container for Classified Papers
- 120 Rotating Drive for Electrical-Arc Machining
- 121 Variable-Displacement Hydraulic Drive Unit

Books and Reports

- 121 Survey of Hand Controllers for Teleoperation

Transfer Mechanisms for Heavy Loads

A soft hydraulic system gently maneuvers loads.

John F. Kennedy Space Center, Kennedy Space Center, Florida

New load-bearing mechanisms produce small motions to transport heavy loads. In the present design, they grasp

trunnions on Space Shuttle payload modules. With modifications, they may be useful in transferring large loads in rail-

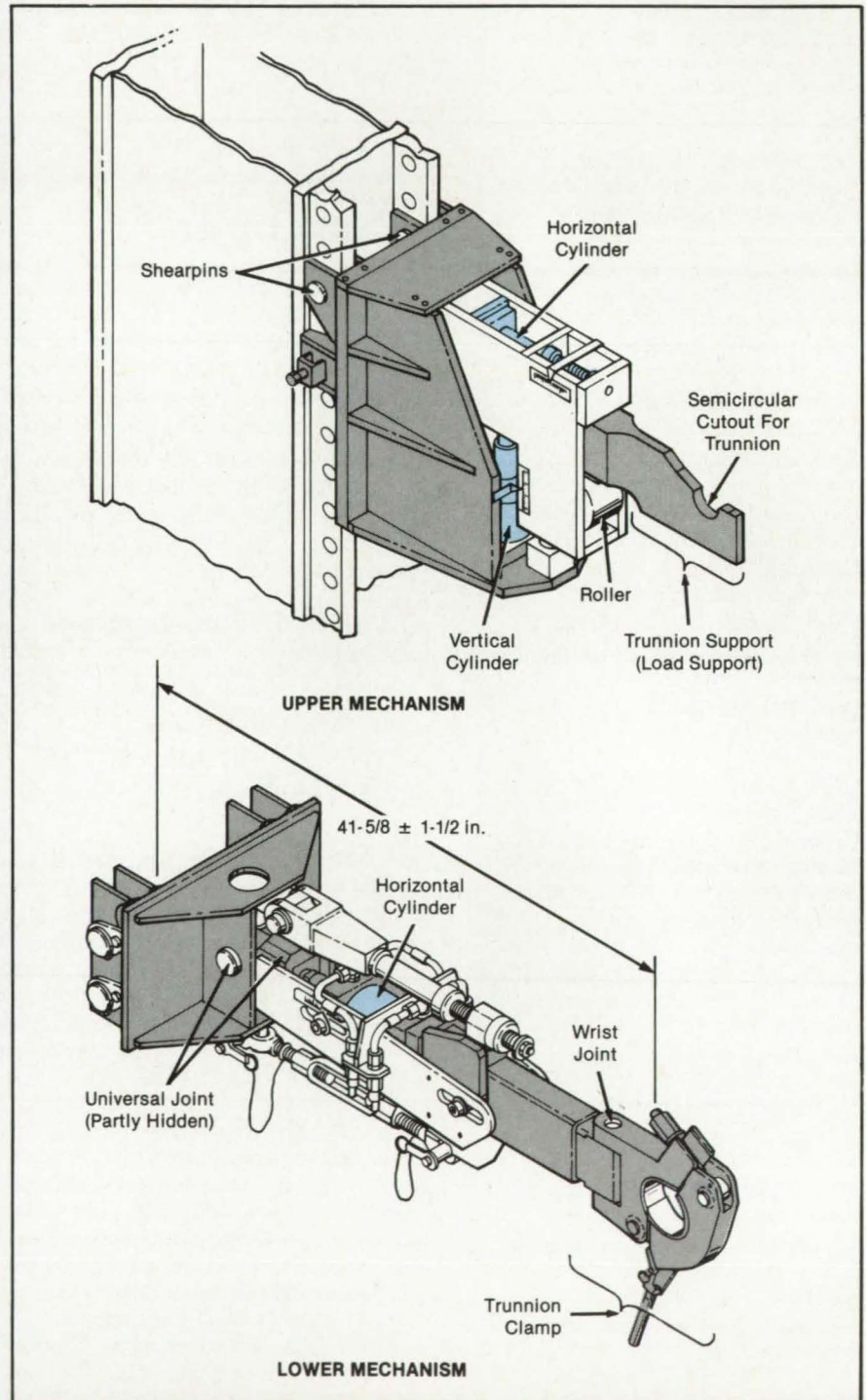

The **Upper and Lower Load-Transfer Mechanisms** attach through mounting holes in a vertical beam which is adjustable for gross positioning. The fine positioning of the load is accomplished by hydraulic cylinders that move the trunnion support and trunnion clamp through short distances.

roads, agriculture, shipping, manufacturing, and even precision assembly of large items.

There are two mechanisms in a set (see figure): An upper one that lifts the load and moves it horizontally and a lower one that pushes or pulls horizontally but allows free vertical motion over a limited range. Both mechanisms are held by shearpins on a vertical beam. To provide a range of vertical positions for different loads, the holes are located along the beam at 10-cm intervals.

The upper mechanism supports loads up to 39 klb (173 kN) and exerts a horizontal force of as much as 16 klb (71 kN) toward or away from the beam. The load is lifted by a single-acting hydraulic cylinder, while the horizontal force is exerted by a double-acting hydraulic cylinder.

The range of vertical motion is +1, -2 in. (+2.5, -5.1 cm), while the horizontal range is ± 1.5 in. (± 3.8 cm). In addition,

coarse-thread screws enable lateral adjustments of ± 0.5 in. (± 1.3 cm) across the beam. While small, these ranges are just sufficient to enable the trunnion supports to move out from under the trunnions.

The lower mechanism also includes a double-acting, 16-klb (71-kN) horizontal cylinder. It contains no vertical cylinder, however: Instead, universal and wrist joints allow the load to move freely in the vertical and lateral directions.

The hydraulic system includes a gas accumulator that acts as a load-relief spring. This is necessary to cushion the load and its receptacles against impacts and distorting forces due to misalignment and vibration. The gas space in the accumulator is filled with nitrogen to a pressure that gives the desired spring stiffness. The damper-needle setting determines the dynamic response of the system by controlling the rate of flow of hydraulic

fluid between the accumulator and the cylinder.

The hydraulic fluid is water with 5 percent lubricant. (Water was chosen because, in the Space Shuttle, it is unlikely to cause damage if spilled.) The hydraulic system is repeated for each direction of each cylinder, so that independent horizontal and vertical displacements and individually adjustable spring and damping rates are available at each trunnion support for precise, gentle positioning of the load.

This work was done by Vincent Cassisi of Kennedy Space Center. For further information, Circle 48 on the TSP Request Card.

Inquiries concerning rights for the commercial use of this invention should be addressed to the Patent Counsel, Kennedy Space Center [see page 21]. Refer to KSC-11292.

Multileg Heat-Pipe Evaporator

Parallel pipes provide high heat flow from a small heat exchanger.

Lyndon B. Johnson Space Center, Houston, Texas

Multiple, parallel, short heat pipes instead of a single, long heat pipe are used on the evaporator of a heat-transport system. As a result, the evaporator is compact rather than extended and is more compatible with existing heat-exchanger geometries. A prototype six-pipe evaporator is only 0.3 m wide and 0.71 m long. With ammonia as the working fluid, it transports heat to a finned condenser at a rate of 1,200 W.

To ensure high heat-transport capacity, each extruded aluminum pipe contains two channels — one for vapor and one for liquid (see figure). Liquid from the condenser flows through the liquid channel and via a bridging wick into circumferential evaporator grooves in the vapor channel. The operation of the heat pipe is explained in more detail in the preceding article.

At the condenser end, the heat pipes are welded to a manifold. In turn, the manifold is welded to a single condenser pipe, which is a two-channel extruded tube like the evaporator pipes. A fin on the condenser pipe radiates heat into the surrounding space so that the vapor in the pipe condenses into a liquid and returns to the evaporator.

This work was done by Joseph P. Alario and Robert A. Haslett of Grumman Aerospace Corp. for Johnson Space Center. For further information, Circle 34 on the TSP Request Card.

This invention is owned by NASA, and a NASA Tech Briefs, January/February 1986

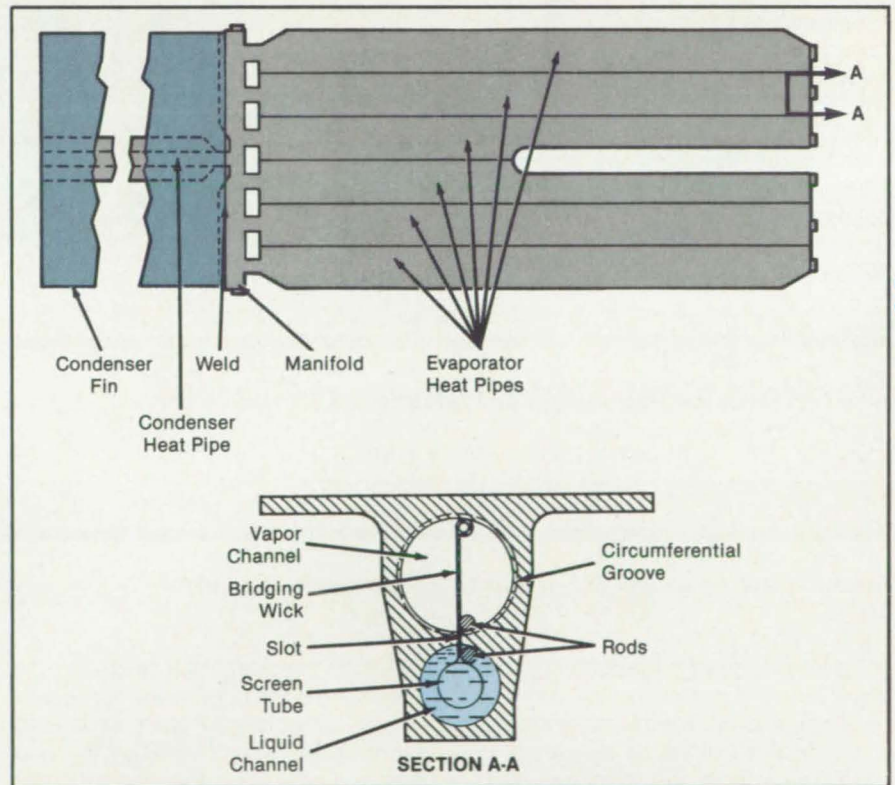

Six Parallel Heat Pipes extract heat from an overlying heat exchanger, forming an evaporator. The vapor channel in a pipe contains a wick that extends into a screen tube in the liquid channel. Rods in each channel hold the wick and screen tube in place.

patent application has been filed. Inquiries concerning nonexclusive or exclusive license for its commercial development

should be addressed to the Patent Counsel, Johnson Space Center, [see page 21]. Refer to MSC-20812.



Manual "Guillotine" Wirecutter

Many wires are cut in one operation.

Lyndon B. Johnson Space Center, Houston, Texas

A "guillotine" wirecutter saves operator time and energy when severing a bundle of wires. The cutter was designed to help astronauts break through spacecraft payload cables while working outside the spacecraft. It could be used on Earth for emergency cable separation or cable trimming in production.

The conventional technique for cutting bundles of wires is to cut the wires individually or in small groups with diagonal cutting pliers. To speed the process, guillotine-style cutters have been produced, but they require hydraulic or compressed-air power sources.

In the manual guillotine cutter (see figure), the wires are prestrung through the cutting block. In the case of a vehicle or structure with installed wires, the wires remain in the block during normal operation, ready to be cut at a moment's notice.

To cut the wires, the operator turns a crank, which drives a recirculating-ball screw. The mechanical advantage of the screw enables it to develop enough force to push the blade through the bundle of wires. In the original spacecraft application, the time to cut all the wires was about a minute.

This work was done by Wayne J. Wedlake of McDonnell Douglas Corp. for Johnson Space Center. No further documentation is available.

MSC-20926

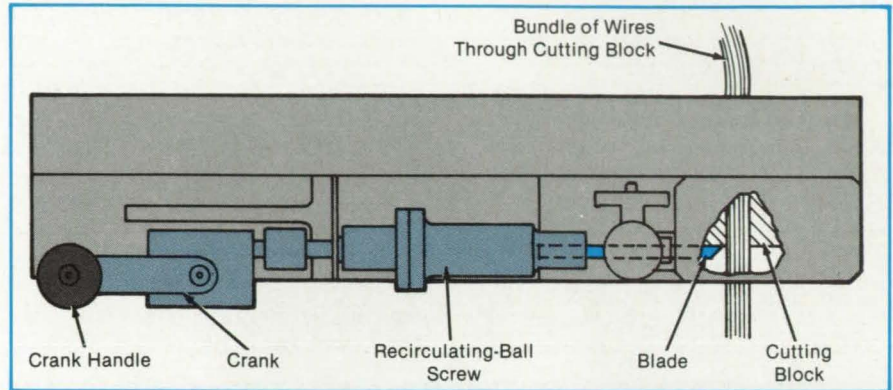

The **Guillotine Wirecutter** is powered by a handcrank. The crank turns a recirculating-ball screw, which pushes the blade through the bundle of wires in the cutting block.

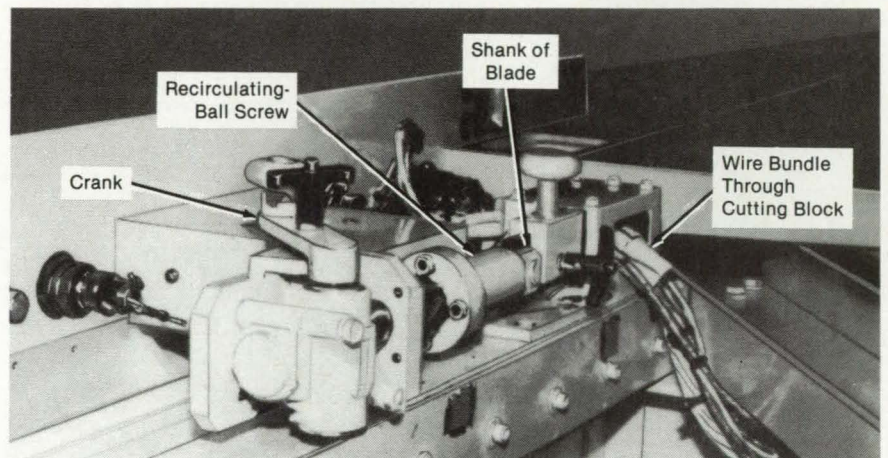

Manifold Coal-Slurry Transport System

Feeding several slurry pipes into a main pipeline reduces congestion in coal mines.

NASA's Jet Propulsion Laboratory, Pasadena, California

A proposed system for pumping a coal slurry out of a mine can serve several continuous-mining machines simultaneously, yet allows individual excavators to be stopped without disrupting production from the other machines. The system is based on a manifold concept in which feeder pipelines from each working entry are joined to a main pipeline that carries the coal slurry out of the panel and onto the surface. The manifold concept makes

coal-slurry haulage much simpler than it is with existing slurry systems. For example, in a room-and-pillar operation utilizing slurry haulage, it is necessary to run a separate pipeline out of the panel for each working excavator. This limits the number of entries that can be operated simultaneously due to the pipeline congestion. By manifolding the pipelines, one reduces the congestion substantially, allowing more working faces, thus higher

production.

In the manifold system (shown in the figure), the excavators drag extensible conveyors, which transport the coal from the advancing excavator, to a portable stationary slurry mixer/injector located in an open crosscut. When a conveyor extends to its full length, the excavator is stopped, and the slurry injector is advanced. This brief shutdown is necessary about once a day. The injector is ad-

NASA Tech Briefs, January/February 1986

vanced when it is disconnected from the feeder pipelines in the crosscut, and then the conveyor is retracted, which pulls the injector up into the next crosscut where another preinstalled set of feeder pipelines is waiting. The pipe connections are made, and mining resumes. Meanwhile, the other excavators continue feeding coal to the main pipe without interruption. This is possible because of an isolation valve in the crosscut that bypasses water into the slurry pipeline when the injector shuts down, thus preventing backwash and maintaining constant flow in the pipeline.

An isolation valve consists of three valves operated in unison: a slurry valve, a water valve, and a bypass valve. Normally, the water valve and the slurry valve would be open so that water could enter the mixer and slurry could leave it. When the mixer is to be shut down, however, the slurry and water valves are closed, and the bypass valve is opened. The bypass valve diverts water from the mixer, sending the water from the supply pipe directly into the feeder pipe. This maintains an adequate waterflow in the main pipe so that the coal particles do not settle out of the slurry and clog the pipe.

Shutoff valves are provided at every point where a feeder pipe joins the main pipe. These valves cut off feeder lines for disassembly and advance into another open crosscut, allowing flow in the main pipe to continue. They also close off feeder sections in case of a leak or other emergency.

The flow velocity in the pipes is estimated to be about 10 ft/s (3 m/s), which is high enough to prevent sedimentation but not so high as to wear the pipes excessively. The crushed coal is mixed with 70 volume percent water, yielding a slurry about three times as viscous as water. This viscosity can be handled without excessive pumping power. The pipe diameters are at least three times greater than the largest-expected coal particle; therefore, there would be little chance of the

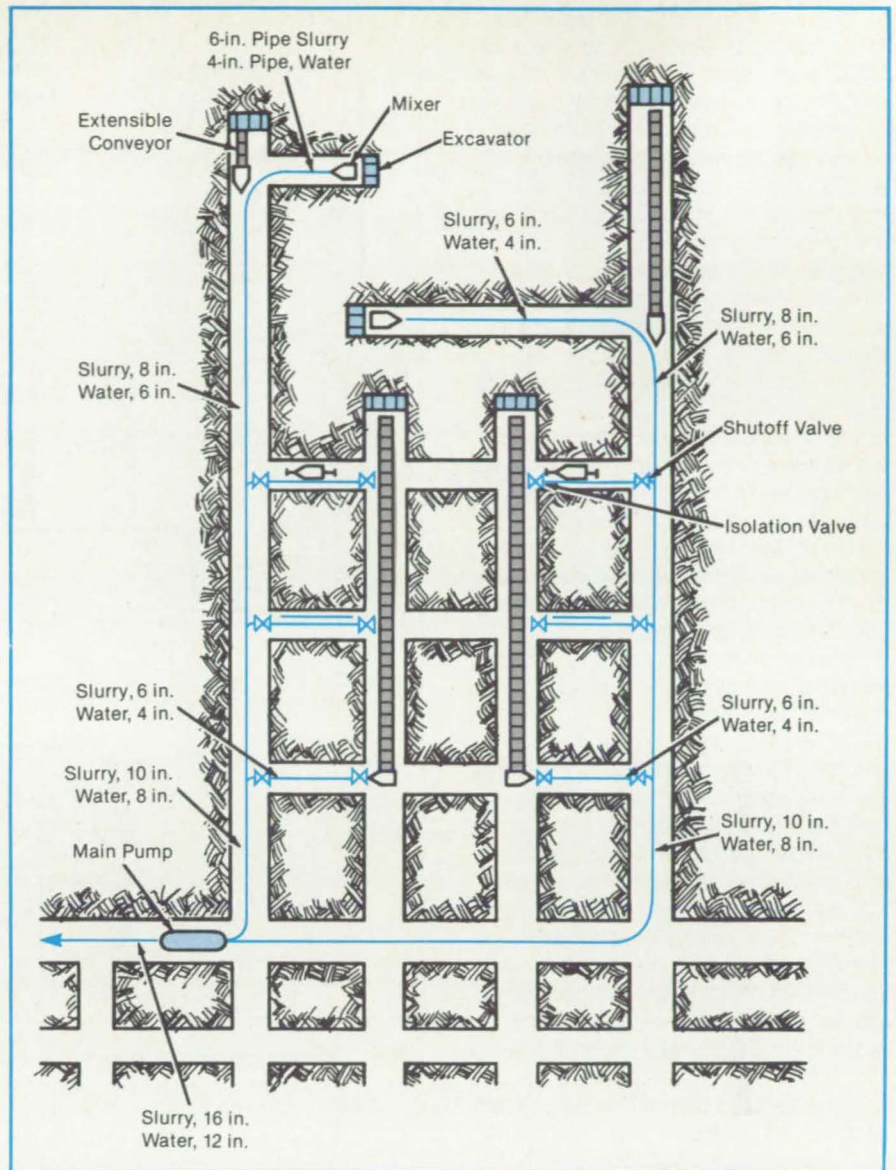

This **Plan View of Room-and-Pillar Mining** with six excavators shows the relationship of excavators, extensible conveyors, mixers, slurry feeder pipes, and slurry main pipes. Diameters of pipes are indicated. The main pump lifts the slurry from the mine to the surface.

pipes becoming plugged, provided that adequate flow is maintained.

This work was done by Sidney G. Liddle, Jay M. Estus, and Milton L. Lavin

of Caltech for **NASA's Jet Propulsion Laboratory**. For further information, Circle 38 on the TSP Request Card. NPO-16471

Heat Pipe Precools and Reheats Dehumidified Air

Precooling and reheating by the heat pipe reduces the operating costs of air-conditioning.

John F. Kennedy Space Center, Florida

Heat-pipe technology is being brought to bear on the problem of conserving air-conditioning energy in a hot, humid environment. In an experimental installation in Florida, an air-to-air heat-pipe exchanger is being used to precool the re-

turning warm air before it enters the cooling coil and to heat the chilled air before it enters the air-conditioned space (see figure). A large-scale heat-pipe system has also been simulated on a computer.

The conditioning of air for comfort in a

hot, humid climate requires a substantial amount of energy to condense and remove the moisture. The conventional practice is to chill the air well below the comfortable temperature to reduce its relative humidity to the comfort level then

to reheat the air with an electric resistance heater, or with such other means as hot-water coils, steam coils, or waste heat from condenser, so that it is not excessively cold when it enters the room.

Reheating is obviously a wasteful process. Not only is energy added to the air to increase its temperature, but the same energy must be removed by the refrigeration machinery when the air is recirculated. In addition to energy costs, reheating increases the costs of equipment and maintenance.

In a system equipped with a heat-pipe heat exchanger, the evaporator section of the heat pipe is in the return-air duct. Liquid inside the evaporator absorbs heat from the warmer return air, evaporates, and passes to the condenser section as vapor. In the condenser, which is in the supply-air duct, the vapor condenses on the inner wall of the heat pipe, thereby transferring heat to the colder supply air. The newly condensed liquid is returned to the evaporator by gravity, capillary action, osmosis, or pumping.

The working fluid may be water or a commercial refrigerant. Wicks around the inner periphery of the heat pipe ensure that the liquid wets the surface for efficient heat transfer. The heat pipe functions well with a relatively small temperature difference between the evaporator and the condenser. Unlike heat pipes for space applications, the pipes for air-conditioning do not have to be particularly small in diameter or meet other stringent requirements. They are therefore fairly simple and inexpensive to manufacture.

A simple thermosiphon heat-pipe heat exchanger, developed and built by the Dinh Co., Alachua, Florida, is used in the Florida experiment. The heat exchanger is constructed from two refrigerant-condenser coils joined by copper tubing. The assembly is evacuated and filled with refrigerant R12 (dichlorodifluoromethane). It has performed well in the first phase of testing.

The presence of heat pipes in the ducts will obstruct the airflow appreciably, and fan power will have to be increased accordingly. However, the fact that the supply air need not be reheated more than compensates for the extra fan requirement. Any increase in the cost of equipment due to the installation of heat-pipe heat exchangers is expected to be recovered in energy savings during a service period of 2 years or less. In the case of new installations, the cost of the heat-pipe heat exchanger is usually compensated by the smaller size of the air-

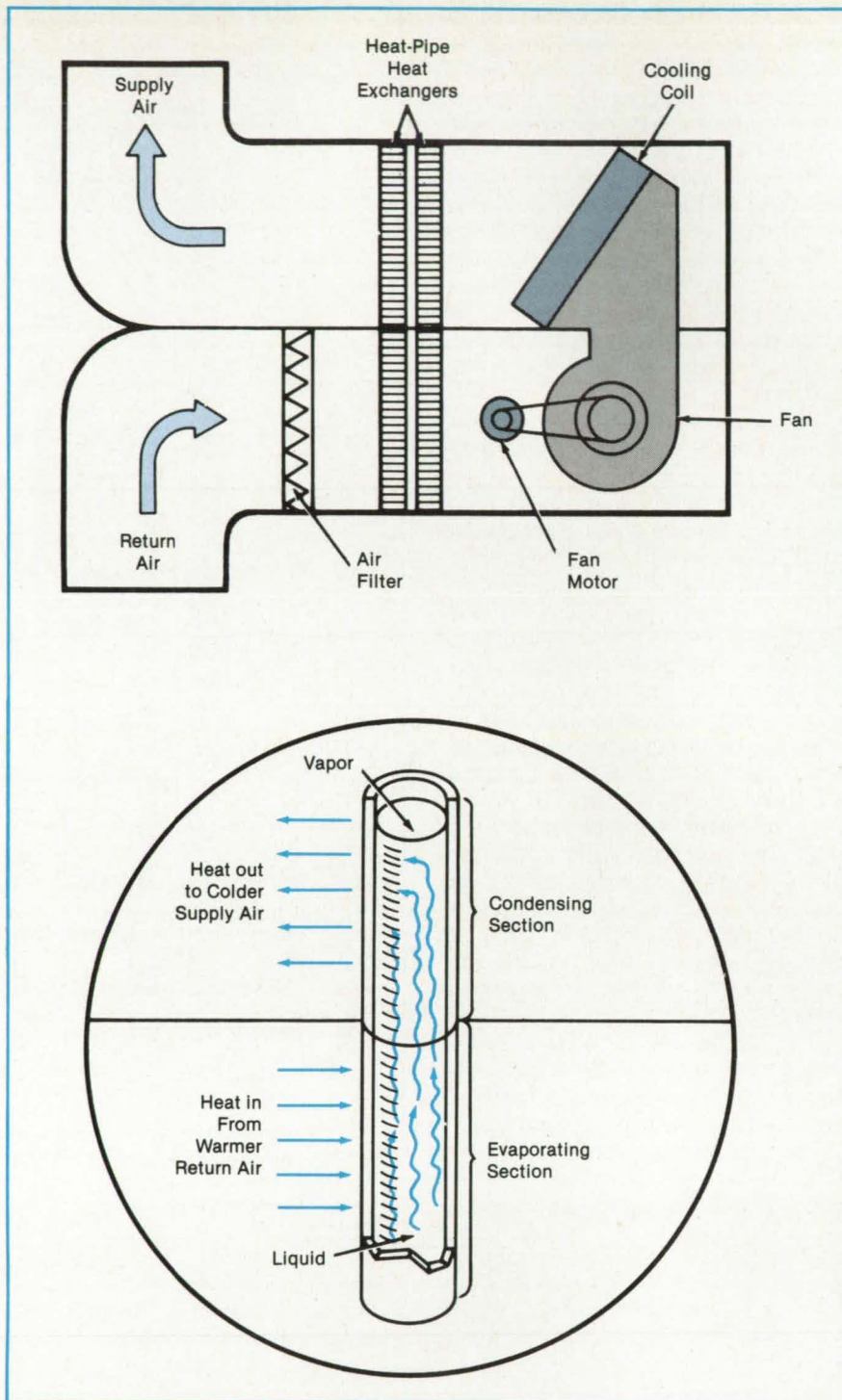

Warm Air Returned from an air-conditioned space and cooled air supplied to it are pre-cooled and reheated, respectively, by each other through a heat pipe.

conditioning plant, which can now be sized to exclude the extra load of the reheating.

*This work was done by Robert C. Koning, Wallace H. Boggs, and U. Reed Barnett of **Kennedy Space Center** and Khanh Dinh of the Dinh Co. for Kennedy*

Space Center. For further information, Circle 65 on the TSP Request Card.

Inquiries concerning rights for the commercial use of this invention should be addressed to the Patent Counsel, Kennedy Space Center [see page 21]. Refer to KSC-11311.

Jig for Removing Rivets

A drill-press jig is used to remove improperly installed rivets.

Lyndon B. Johnson Space Center, Houston, Texas

A drill-press jig makes it possible to drill accurately-centered, straight holes through rivets. The key component of the jig is a drill bushing with a spherical recess machined into the base. The contour of the recess matches the contour of the rivet head.

Rivets that have not been installed correctly are usually very difficult to remove and replace. The obvious method is to drill out the rivet along the axis and scrape away the rivet metal that remains after drilling. Without the jig, however, the drill bit tends to slip off the rivet head, damaging

the surrounding material, or to wander, creating an oversized hole. Often, it seems preferable to scrap riveted parts rather than refasten them.

The modified bushing and the components of the jig are shown in the figure. The bushing is slipped into a hole in a handle, and the flat head of a screw on the handle mates with a notch machined into the bushing. The bushing is placed over the rivet, and the drill is inserted in the bushing. An operator holds the jig handle with one hand and controls the drill with the other hand. The handle and screw head thus

hold the drill bit in place over the center of the rivet so that the rivet can be drilled out through its axis. With the rivet thus removed, the parts can be separated and re-fastened or reused elsewhere.

This work was done by Thomas P. Roebuck and Al E. Houser of Rockwell International Corp. for Johnson Space Center. No further documentation is available.

Inquiries concerning rights for the commercial use of this invention should be addressed to the Patent Counsel, Johnson Space Center [see page 21]. Refer to MSC-20757.

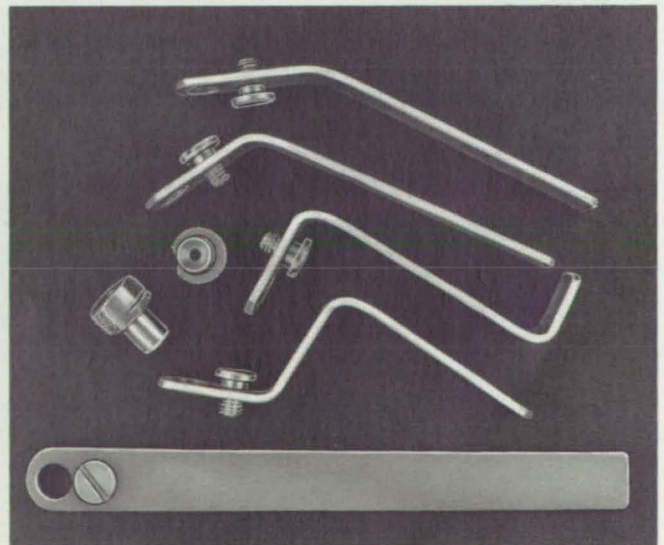
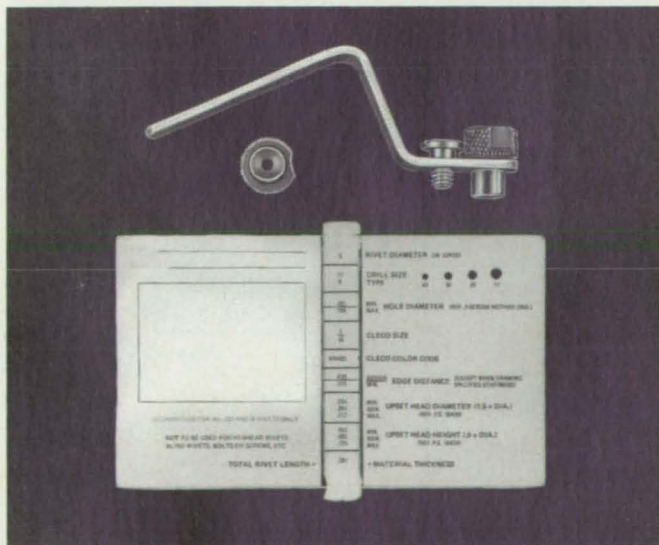
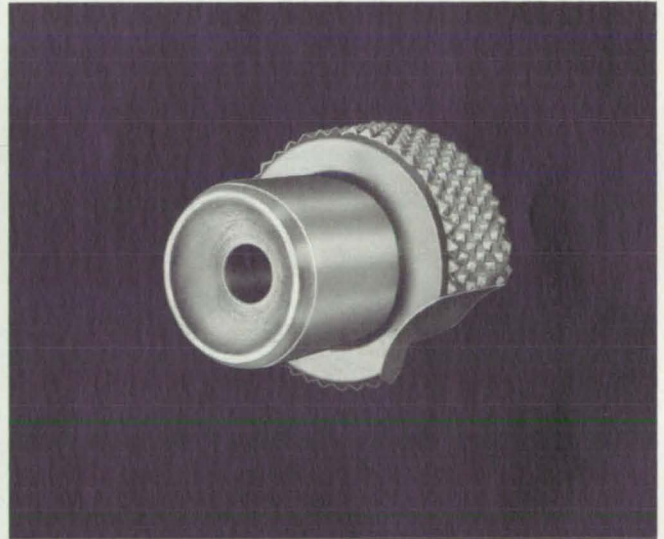
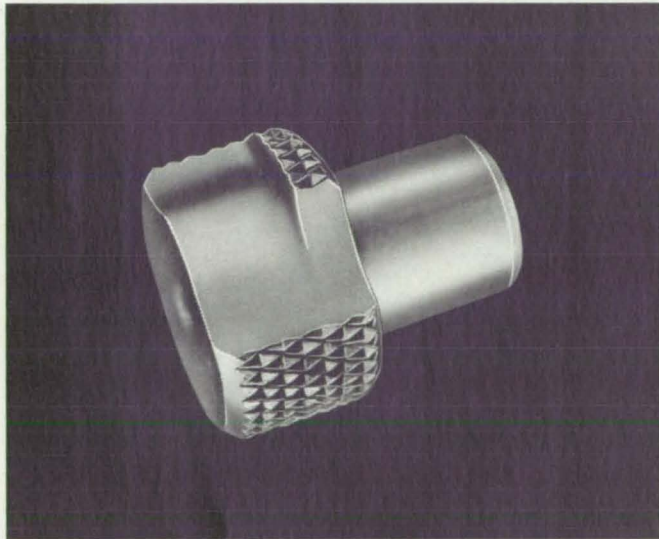

The **Contoured Bushing** (top) fits over the rivet head. The operator holds the bushing in place over the rivet with the handle (bottom left) while inserting the bit of the drill into the bushing bore. Standard bushings can be adapted to a variety of rivet sizes. Similarly, the handle length and offset angle can be adapted to the geometry of a particular removal situation (bottom right).

Detection of Machining Chips by Pressure Reversal

Inaccessible interior spaces are inspected acoustically.

Marshall Space Flight Center, Alabama

Loose machining chips or other particulate contaminants in certain machinery can be detected by the sound they produce when they are moved by a rapidly-reversed pressure differential. Currently used techniques for identifying loose contaminants, such as high-volume water flushes and borescope inspection of components, cannot reach all parts of turbopumps and other intricate

assemblies.

In acoustic inspection, the inlet and outlet ports of a component are connected to pneumatic hoses of an apparatus that rapidly reverses the induced pressure differential. If there are loose particles inside this component, they will generate noise that is detected by a series of contact microphones attached to the component. The noise indicates

the general location of the contaminants, and its characteristic may help in identifying the particles from their acoustic signatures.

This work was done by Lynn M. Wyett of Rockwell International Corp. for Marshall Space Flight Center. No further documentation is available.
MFS-29076

Digital Controller for a Remote Manipulator

Sealed forces and displacements are fed back to the operator to facilitate control.

NASA's Jet Propulsion Laboratory, Pasadena, California

A controller for a remote manipulator has a computer link instead of a mechanical link or servomechanism between the control station and the manipulator arm. The master arm, which an operator uses to control the manipulator, therefore does not have to resemble the slave arm either kinematically or dynamically. The master arm can be smaller and lighter or larger and

heavier than the remote manipulator arm. It can also require a smaller or larger volume in which to move.

In an experimental version of the controller, the master arm is hand-operated. The slave arm has force and torque sensors at the wrist and proximity, touch, and slip sensors at the hand.

The controller hand is located at a con-

trol station, which also includes two-dimensional and stereoscopic television displays; graphical displays for proximity, touch, slip, force, and torque information; audio alarms; and control switches. The slave arm is at a remote site that includes a television camera for viewing the manipulator.

The controller uses a distributed micro-computer system for data processing (see

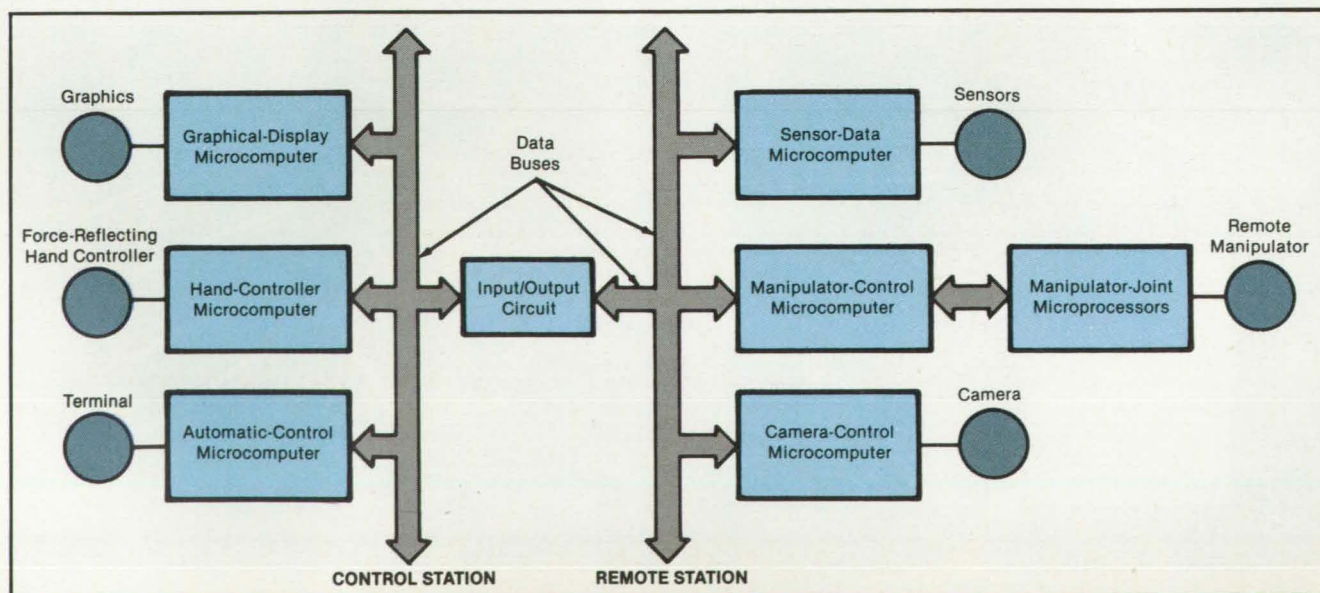

Processing of Data Is Distributed among six microcomputers. Each microcomputer is dedicated to a specific task and communicates with the others at the same station or at the opposite station.

figure). Three microcomputers at the control station are respectively dedicated to control of the feedback mechanisms in the controller hand, operation of the graphical displays, and automatic control of certain functions to ease the burden on the operator. Three microcomputers at the remote

station control the slave arm, control the camera, and process the sensor data, respectively. Each microcomputer communicates with the others at the same station through a shared bus and with the microcomputers at the opposite station over a shared input/output channel.

This work was done by Antal K. Bejczy and Sukhan Lee of Caltech for NASA's Jet Propulsion Laboratory. For further information, Circle 8 on the TSP Request Card. NPO-16470

Portable Hydraulic Powerpack

This proposed unit would be recharged by chemical energy.

John F. Kennedy Space Center, Florida

A proposed rechargeable hydraulic powerpack would function as a lightweight, compact source of mechanical energy. The unit could have applications driving wheelchairs and operating drills, winches, and other equipment in remote areas. It could also replace electric motors and internal-combustion engines as a source of power in explosive atmospheres.

The powerpack would employ a slowly burning solid chemical charge to generate hot gas (see figure). The gas would turn the rotor of a turbine, which in turn would drive a pump that would pressurize the hydraulic fluid in an accumulator. The pressurized fluid can then be used on demand to do work — rotating the shaft of a hydraulic motor, for example.

One candidate for the solid charge material is a combination of rubber and ammonium nitrate. This charge is safe and has high energy content in relation to its mass. Its combustion products could easily be filtered to remove objectionable components. A charge composed of sodium azide and copper oxide is also safe and, although its energy content is less, its product gas is nitrogen, which can ordinarily be released directly to the atmosphere.

This work was done by Loren A. Anderson and Rod L. Henry of the University of Central Florida, Otto H. Fedor of Lockheed Corp., and Lester J. Owens of Planning Research Corp. for Kennedy Space Center. No further documentation is available.

Inquiries concerning rights for the commercial use of this invention should be addressed to the Patent Counsel, Kennedy Space Center [see page 21]. Refer to KSC-11318.

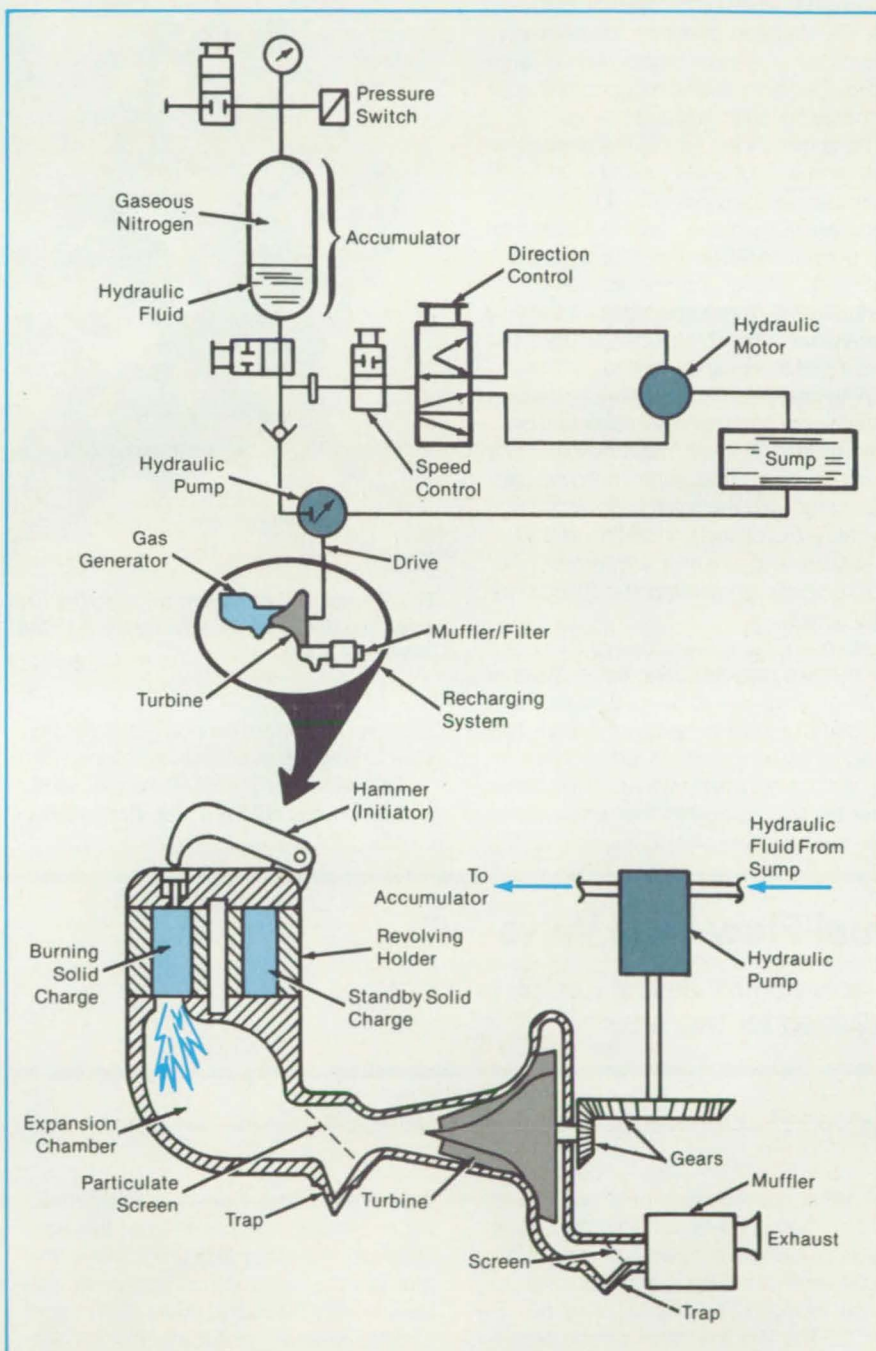

The **Self-Contained Hydraulic Powerpack** derives its energy from a solid chemical charge. The combustion of the charge would be initiated by a small hammer, and a revolving feeder would replace charges that have been expended. The combustion gases would cool during expansion in the turbine and thus would not be too hot for release to the atmosphere.

Oscillation Damper With Two Spring Rates

Bellows and springs rapidly damp the vibration of a long, slender boom.

NASA's Jet Propulsion Laboratory, Pasadena, California

Hydraulic damping is used in a device originally developed to stabilize a vibrating structure in space. The mechanism is especially useful for arresting the oscillatory motion of a slender boom with a large mass. On Earth, such configurations arise in the design of masts and cranes.

As shown in the figure, the device has two primary bellows chambers. Each chamber contains hydraulic fluid that is alternately compressed and expanded as the boom oscillates. The fluid flows back and forth through narrow spaces in the center frame. These spaces resist the flow somewhat, absorbing energy from the boom and damping its motion.

A temperature-compensation bellows maintains an approximately constant pressure of fluid in each main bellows. The temperature-compensation bellows communicates with the main bellows through an orifice that allows a small flow of fluid for pressure and volume adjustment but blocks significant oscillation-induced pressure surges.

Normally, the springs are retracted, and the bellows provide spring force. When a higher spring rate is needed, however, a motor (not shown in the figure) turns a pair of acme screws — one a left-hand screw, the other a right-hand screw. The screws drive the springs against the center frame.

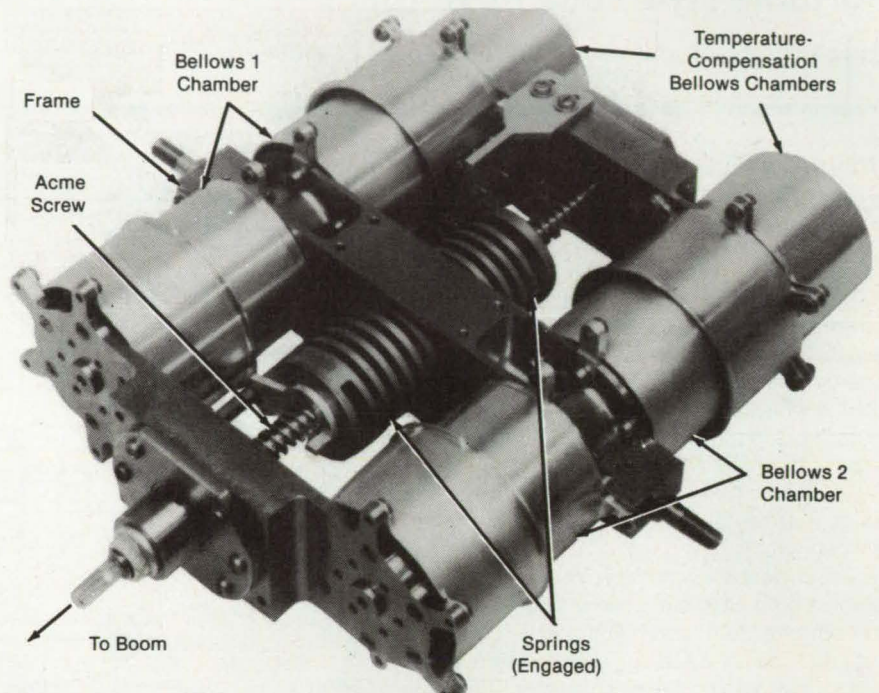

This **Damping Mechanism** will stop the oscillation of an attached boom. Two bellows provide fluid damping. The springs are engaged when extra spring force is required. Otherwise they are retracted.

In that position, the springs assist the bellows to limit the oscillation excursion.

This work was done by Donald R. Sevilla of Caltech for **NASA's Jet Propulsion**

Laboratory. For further information, Circle 4 on the TSP Request Card. NPO-16223

Dual-Flow-Rate Valve

A flow-control device can be precisely adjusted for two rates.

Lyndon B. Johnson Space Center, Houston, Texas

A valve supplies high-pressure gas at either of two preselected flow rates. The valve is adjustable between 0.12 and 1.2 lb/s (0.054 and 0.54 kg/s) of hydrogen at 3,300 lb/in.² (23 MN/m²) and 80° F (27° C). The two flow rates can be preadjusted between these limits in increments of 0.01 lb/s (0.0045 kg/s).

The flow is controlled by a solenoid-operated two-position poppet (see figure). The stroke of the poppet — and therefore

the two flow rates — is adjusted by inserting or removing shims to alter the positions of the poppet stops. The mass flow through the valve varies approximately linearly with the poppet travel. The poppet and its sleeve, including the stroke-adjusting shims, is a self-contained assembly that can be calibrated for flow in a fixture and stocked for later use.

The poppet stops are conical so that the poppet nests firmly at the end of each

stroke without lateral vibration. The wear of the labyrinth-seal-bearing surfaces is thus minimized.

The gas passes through the poppet orifice at sonic velocity. The surfaces at and near the orifice are at a low angle of attack with respect to the flow to reduce the energy released by the impact of particles entrained in the gas. The interior surface of the pipe adjacent to the valve exit port may be shielded with a material that

NASA Tech Briefs, January/February 1986

resists impacts and ignitions caused by impacts.

This work was done by Richard H.

Allbritain of Rockwell International Corp. for **Johnson Space Center**. For further information, Circle 53 on the TSP Request

Card.
MSC-20849

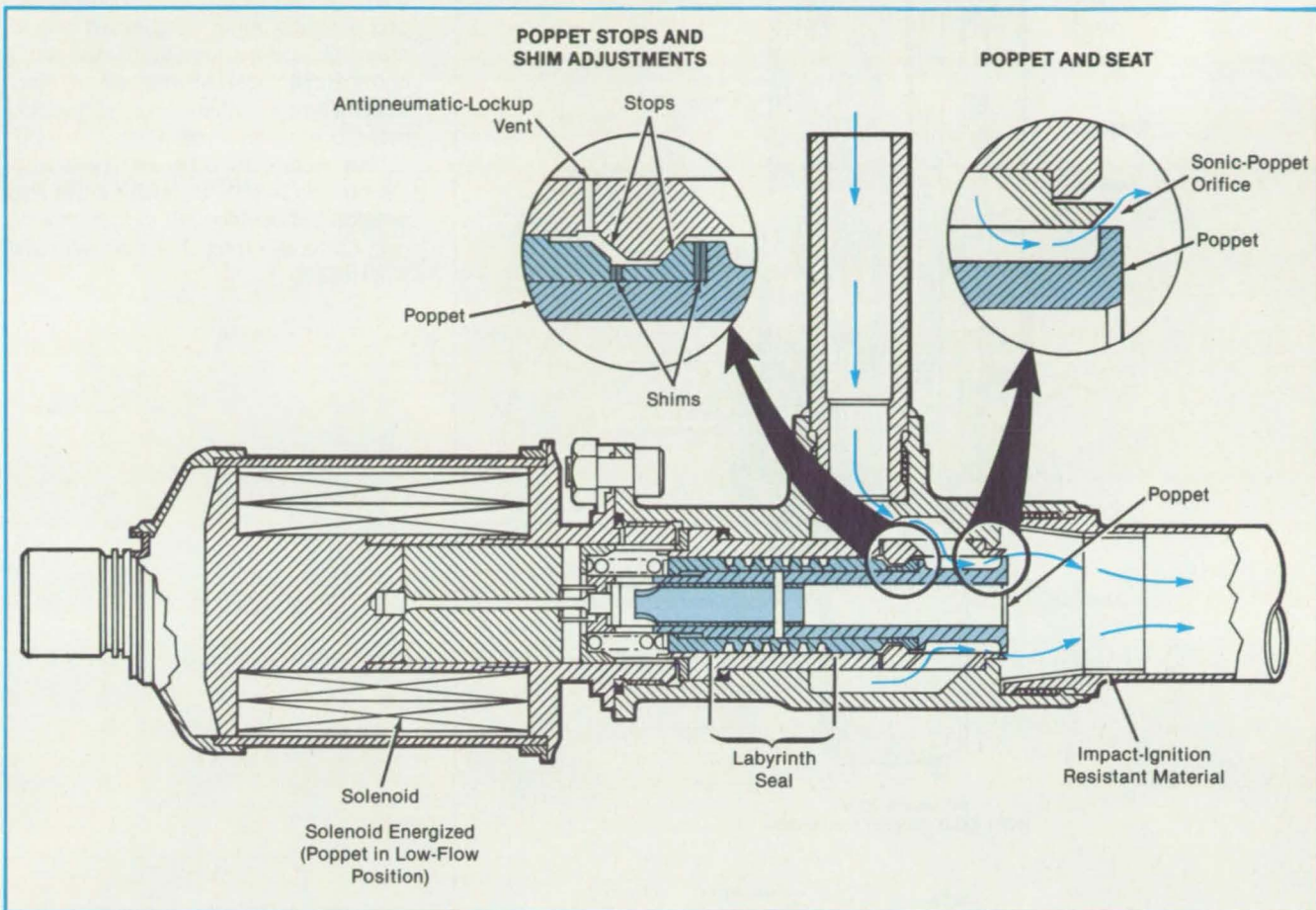

The **Heart of the Two-Position Valve** is a sliding poppet. At its far-right position, the poppet allows a low flow. At its far-left position, it allows a high flow.

Rotary Joints With Electrical Connections

Power and data are transmitted on many channels.

NASA's Jet Propulsion Laboratory, Pasadena, California

Two different rotary joints are equipped with electrical connections between the rotating and stationary parts. One joint transmits axial thrust and serves as the interface between the spinning and nonspinning parts of the Galileo spacecraft. The other is a scanning (limited-rotation) joint that aims scientific instruments from the nonspinning part. Selected features of both may be useful to designers of robots, advanced production equipment, and remotely controlled instruments.

The spinning joint includes a stator tube placed between inner and outer rotor tubes (see figure). The concentricity of the three tubes is enforced by inner and outer bearings at the lower end. The axial thrust is transferred between the
NASA Tech Briefs, January/February 1986

rotor and stator by a pair of duplex bearings.

In both the spinning and scanning joints, the torque between the rotor and the stator is supplied by two 24-pole dc torque motors oriented to minimize the magnetic cogging torque and the external magnetic field of the combination. An optical encoder in each joint signals the angular position for rotor pointing and motor commutation. The angular resolution of each encoder is 20 arc-seconds.

In the spinning joint, the inner tube supports the inner halves of a stack of 23 rotary transformers with manganese-zinc ferrite half cores. These transformers are used for data transmission at 800 kb/s. Four slipping modules contain a total of 48 hard-silver slippers contacted by

brushes molded of silver/molybdenum disulfide/graphite: These transmit power and low-frequency data.

The scanning joint is less complicated than the spinning joint. A hollow shaft extending from the housing holds two bearings that support the rotor. The instrument platform is bolted to the rotor flanges. Since the rotation of this joint is limited to 210°, flexing connections can be used. A 200-wire circuit assembly in the hollow shaft transfers signals and power between the rotor and stator. The wires are on four 50-wire tapes, with two wound clockwise and two wound counterclockwise to minimize the spring torque.

The bearings and lubricants are essential to the long-term reliability of the joints. All of the bearings are made with 440C

stainless-steel balls, chromium-alloy rings, and polytetrafluoroethylene ball separators. The bearings are designed with a variety of precise contact angles and preloads. All are pretreated with tricresyl phosphate, then lubricated with a commercial radiation-resistant oil. Each bearing cavity contains an acrylic copolymer lubricant reservoir.

This work was done by Fredrick W. Osborn of Caltech for **NASA's Jet Propulsion Laboratory**. For further information, Circle 82 on the TSP Request Card. NPO-16250

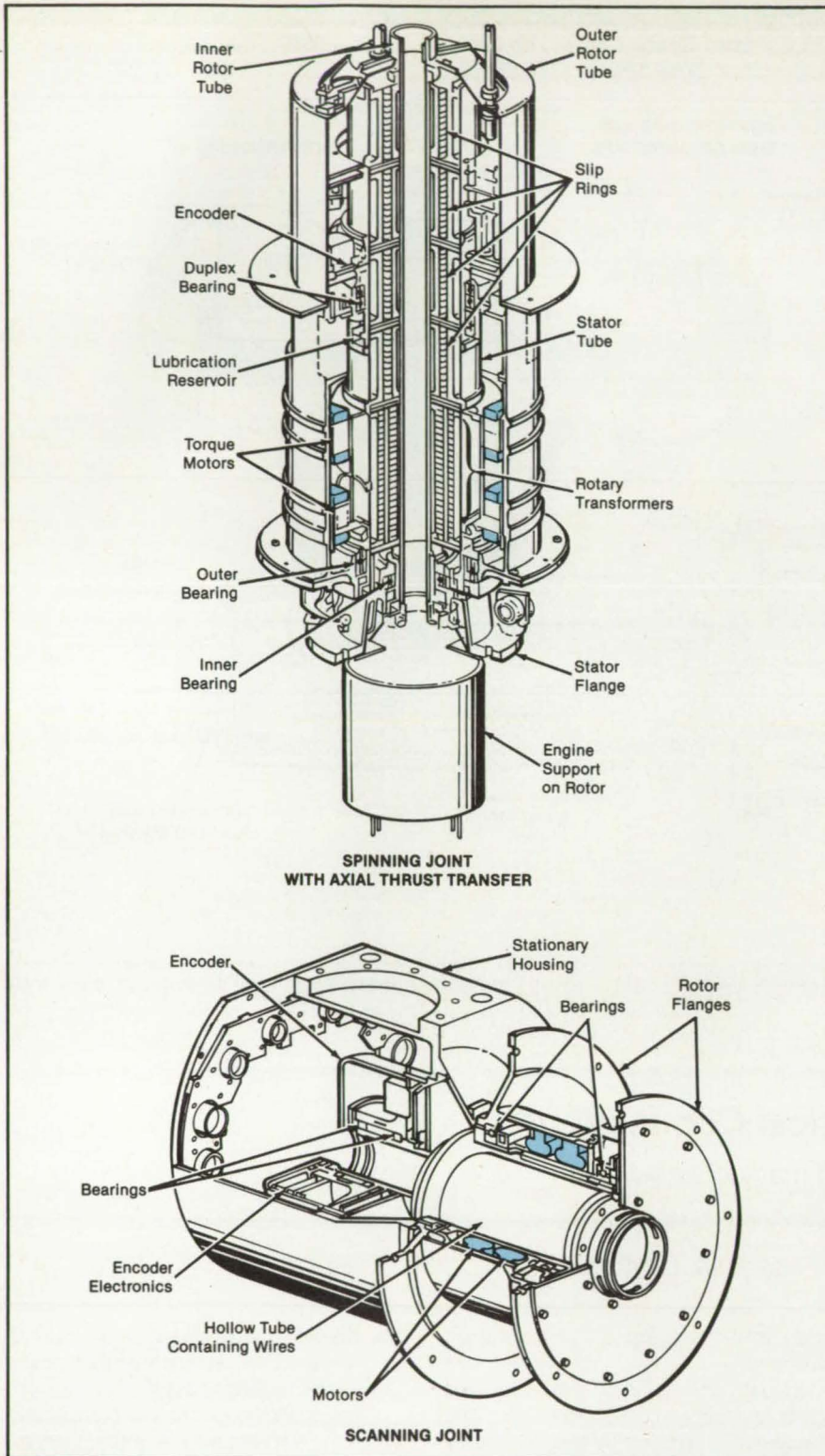

The **Rotary Joints** are of two types: a spinning joint (above) and a limited-rotation scanning joint (below). The spinning joint contains rotary transformers and sliprings to transmit signals and power. The scanning joint uses flexible wire connections.

Emergency Brake for Tracked Vehicles

A clamping mechanism brings the vehicle to a smooth halt.

Lyndon B. Johnson Space Center, Houston, Texas

A caliper brake automatically stops a tracked vehicle as the vehicle nears the

end of its travel. The mechanism includes two brake pads mounted on the track rails,

which engage a bar on the vehicle when it approaches the end of the line. The

NASA Tech Briefs, January/February 1986

emergency-braking system may be suitable for elevators, amusement rides and machine tools.

The brake pads are aligned parallel to the rails (see figure) and are continuously energized — by spring or air pressure — so that a spacer block is clamped between the pads.

When the vehicle approaches the brake, the bar dislodges the spacer block. A polytetrafluoroethylene coating on the block enables it to slide easily from between the brake pads. The pads then grip the bar, decelerating the vehicle. A pressure-activated switch on the air-pressure supply or a limit switch on the brake pads, or both, is triggered when the brake operates and sends a signal to cut off the vehicle power.

This work was done by Gary L. Green and Sonne L. Hooper of Pan American

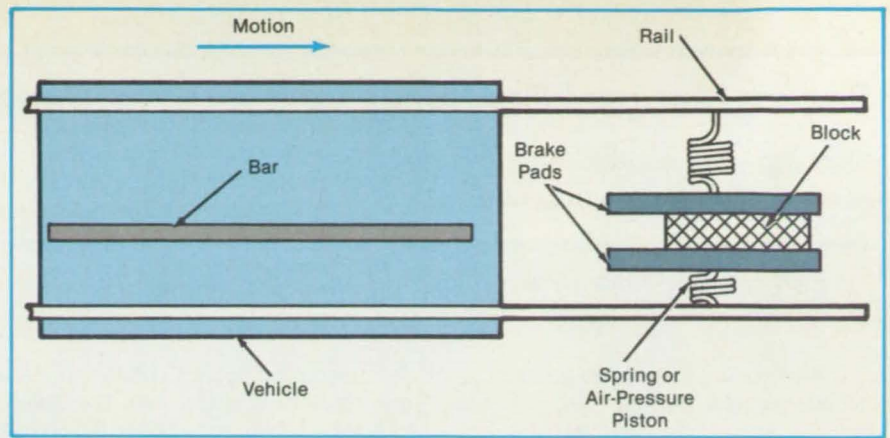

A Bar on the Vehicle, traveling to the right, dislodges the block between the brake pads. The pads then press against the bar, slowing the vehicle by friction.

World Airways, Inc., for Johnson Space Center. For further information, Circle 22

on the TSP Request Card. MSC-20513

“Curtainless” Window

Liquid flow switches this window from transparency to opacity.

Lyndon B. Johnson Space Center, Houston, Texas

A laminated window is switched from transparency to opacity when liquid is pumped out of the spaces between the lamina. The window is made from panes of glass or plastic, with a sheet of polytetrafluoroethylene centered in the gap between them. The liquid is pumped into and out of the spaces between the sheet and the panes.

With no liquid in the spaces, the window is translucent or opaque (depending on the thickness of the sheet). To make the window transparent, the spaces are filled with liquid from a reservoir. Transparency results when the liquid fills in the surface irregularities of the sheet. When the liquid is pumped out, the window again becomes translucent or opaque.

As indicated in the figure, polytetrafluoroethylene is used for the sheet. At low thickness, it has a milk-white translucency. At high thickness, it is opaque.

The liquid should have a refractive index between 1.30 and 1.40, close to that of polytetrafluoroethylene. Acetone, isopropyl alcohol, or trichlorotrifluoroethane work well.

If the sheet of polytetrafluoroethylene is only 2 to 3 mils (0.05 to 0.08 mm) thick, it can be made transparent by wetting only one of its surfaces. As the sheet thickness increases, however, better results are obtained when both surfaces are wet.

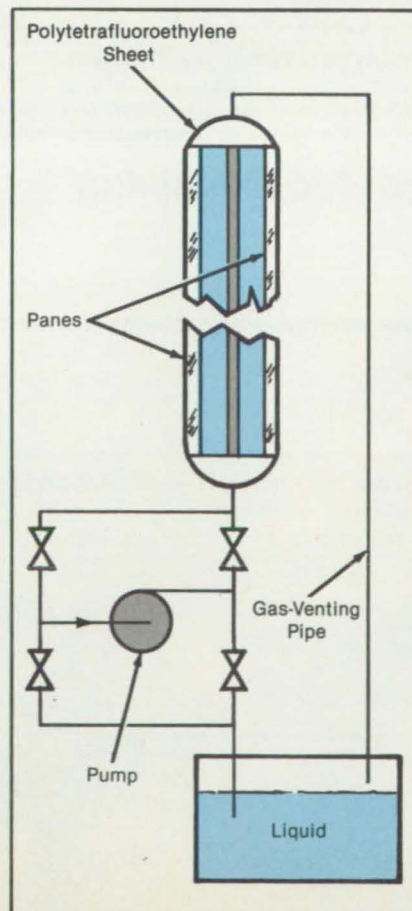

The panes need not be flat. They may be shaped in parallel curves. For decorative purposes, the sheet may be patterned to give alternating dark and light areas in the window.

The pump that fills and empties the voids may be controlled manually. Alternatively, it may be operated by a photoelectric sensor when light entering the window rises above or falls below a preset level.

This work was done by Dale L. Connelly of Johnson Space Center. For further information, Circle 1 on the TSP Request Card.

This invention is owned by NASA, and a patent application has been filed. Inquiries concerning nonexclusive or exclusive license for its commercial development should be addressed to the Patent Counsel, Lyndon B. Johnson Space Center [see page 21]. Refer to MSC-18417.

A Pump Transfers Liquid from the reservoir to the window voids. The gas-venting pipe transfers gas to the reservoir when the window is filling and to the window when the window is emptying.

Secure Disposal Container for Classified Papers

Meshing steel combs retain papers when container is overturned.

NASA's Jet Propulsion Laboratory, Pasadena, California

Deflectors are sometimes installed at the opening of a "secure" disposal container to stop people from reaching into the container and withdrawing discarded documents. If the container is tipped, however, the deflectors may not prevent the refuse from falling out.

One simple solution to this problem is

illustrated in the figure. Comblike shutters are installed on hinges near the deflectors. If the container is upright, the combs hang vertically and out of the way. When the container is tipped or overturned, gravity forces one or both of the combs to fall over the opening. When this happens, the teeth intermesh and the container

opening is covered, preventing its contents from falling out.

This work was done by Earl R. Collins, Jr., of Caltech for NASA's Jet Propulsion Laboratory. For further information, Circle 60 on the TSP Request Card. NPO-16517

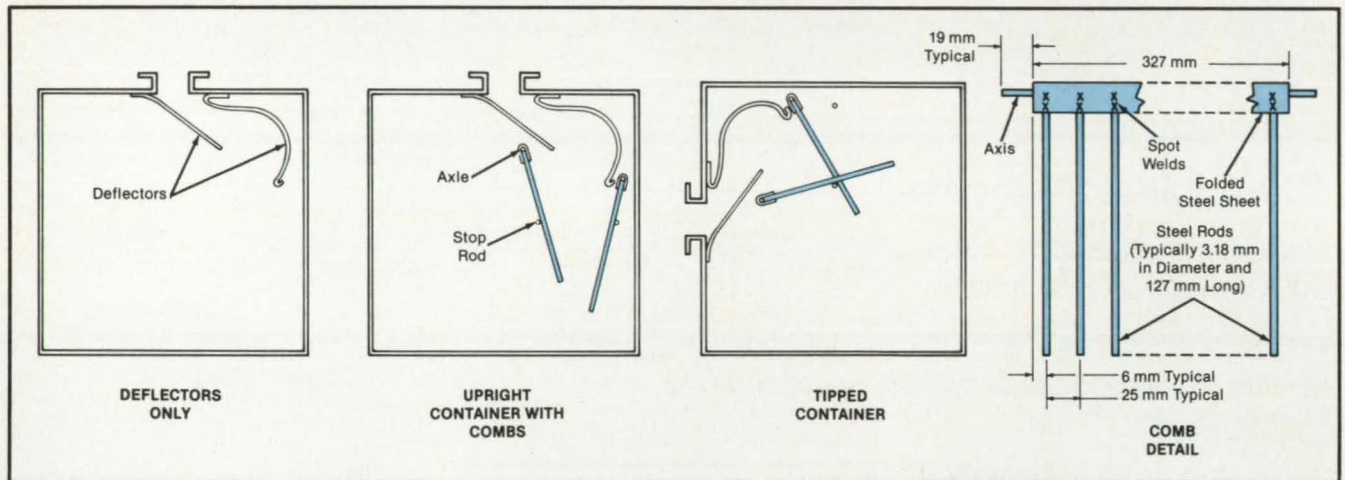

Pivoted Combs Swing to close the opening if the container is tilted by more than a few degrees. The interdigitated combs not only keep paper in the container but also act in combination with the deflectors to prevent the contents from being read through the opening.

Rotating Drive for Electrical-Arc Machining

A rotating electrode produces round holes with untapered walls.

Marshall Space Flight Center, Alabama

A rotating drive improves the quality of holes made by electrical-arc machining. The mechanism (Uni-tek, rotary head, or equivalent) is attached to an electrical-arc system. The drive rotates the electrode as though it were a mechanical drill, while an arc disintegrates the metal in the workpiece, thereby creating a hole. The rotating electrode method is often used in electric-discharge machining. This NASA innovation is an application of the technique to electrical-arc machining.

The hole is more nearly round than if there was no rotation. In addition, the hole

wall is more nearly parallel to the hole center axis, whereas previously the wall would have had more taper.

This work was done by C. D. Fransen of

Rockwell International Corp. for Marshall Space Flight Center. No further documentation is available. MFS-19946

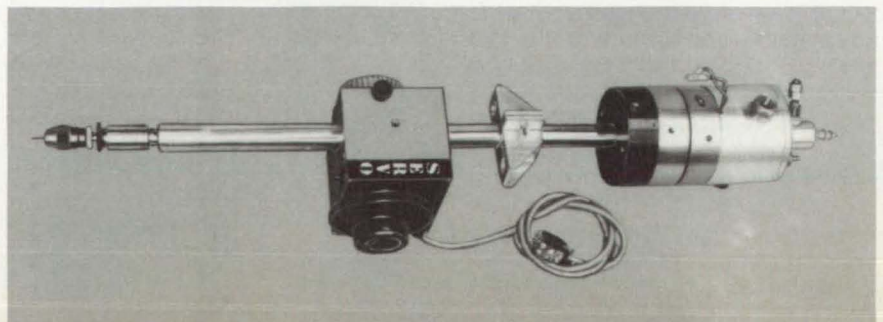

This **Rotary Head** for electrical-arc machining rotates an electrode or workpiece.

Variable-Displacement Hydraulic Drive Unit

Hydraulic power would be controlled through multiple feedback loops.

Lyndon B. Johnson Space Center, Houston, Texas

In a proposed hydraulic drive unit, the power would be closely matched to the demand, thereby saving energy. The concept may be applicable to machine tools, aircraft controls, and marine controls.

The concept is illustrated in the figure. The hydraulic flow to and from the motor is adjusted by the motor-control valve connected to the wobbler. The wobbler angle determines the motor-control-valve position, which in turn determines the motor displacement.

The wobbler is controlled by the wobbler piston, which is hydraulically positioned by the wobbler-control valve. Three mechanical feedback loops feed into the wobbler-control valve by the summing of forces: The wobbler position is fed back by a spring force. The motor-shaft velocity is fed back hydraulically through the governor. The external position-command signal is supplied as the pressure analog of an externally-generated electrical position-error signal. This force-summing scheme minimizes backlash by not involving mechanical linkages.

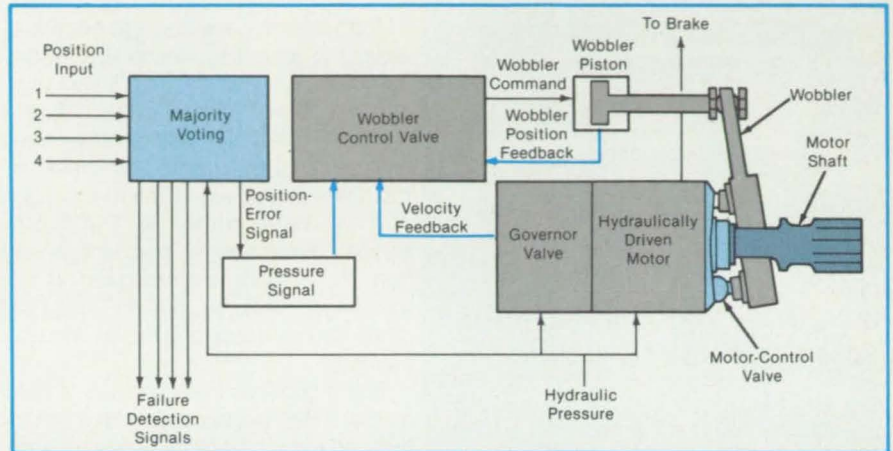

Three Feedback Signals are fed to the wobbler-control valve to match the flow of hydraulic power to the demand.

This work was done by David J. Lang, David J. Linton, and Albert Markunas of Sundstrand Energy Systems for Johnson Space Center. No further information is available.

Title to this invention has been waived

under the provisions of the National Aeronautics and Space Act [42 U.S.C. 2457(f)], to the Sundstrand Corp., Rockford, IL 61125.

MSC-20728

Books and Reports

These reports, studies, and handbooks are available from NASA as Technical Support Packages (TSP's) when a Request Card number is cited; otherwise they are available from the National Technical Information Service.

Survey of Hand Controllers for Teleoperation

A report surveys handgrip designs, control-input devices, and control strategies.

An 83-page report presents a comprehensive survey of hand-controller technology in three major categories: handgrip design, control-input devices, and control strategies. The approach taken in the review is to identify and describe existing handgrips, control-input devices and control strategies, and new components and techniques that may become elements of advanced hand controllers to satisfy increasing performance requirements for NASA Tech Briefs, January/February 1986

teleoperation in the future.

Fourteen handgrip designs are presented and evaluated relative to four major categories; engineering-development requirements, controllability, human/handle interaction, and human limitations made apparent by the particular handle design. A brief analysis is made of the attributes shared by the most satisfactory handles.

Twelve hand-controller input devices are reviewed and evaluated — each solely on its characteristics and without regard for the control strategy used with the device. The evaluations are given in terms of 17 parameters: (1) task performance, (2) configuration feedback, (3) force feedback, (4) controller/slave correspondence, (5) operating volume, (6) operator workload, (7) human limitations, (8) cross-coupling, (9) singularities, (10) anthropomorphic characteristics, (11) physical complexity, (12) control-implementation complexity, (13) control/display interference, (14) accuracy, (15) technological availability, (16) cost, and (17) reliability.

Twelve general manipulator-control strategies ("control modes") are surveyed and evaluated. Only the modes are

considered, but not such specific servo-controls as proportional or pseudoderivative. The control modes have been divided into four primary categories, which are representative of the more successful techniques: rate, unilateral position, bilateral position, and operator-aiding control.

The report concludes by raising a number of questions about the design of handgrips and control-input devices and about teleoperation control strategy and proposes a number of simple, first-phase experiments directed toward the development of empirical design rules for space teleoperator controllers. An extensive list of references supporting the state-of-the-art review is at the end of the report. The references are organized in the order quoted within the text (62 sources) and as a general bibliography of related literature (127 sources).

This work was done by Thurston L. Brooks and Antal K. Bejczy of Caltech for NASA's Jet Propulsion Laboratory. To obtain a copy of the report, "A Survey of Hand Controllers for Teleoperation," Circle 88 on the TSP Request Card. NPO-16610



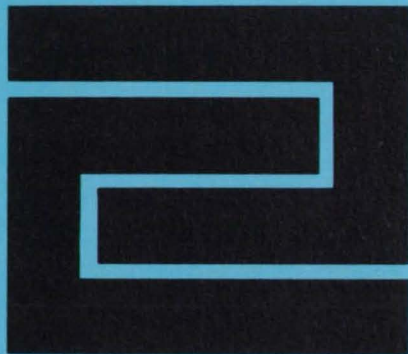

Hardware, Techniques, and Processes

- 122 Attaching Metal Fasteners to Silica Tiles
- 123 Compact Plasma Deposition Chamber
- 123 Lubricating Holes for Corroded Nuts and Bolts
- 124 Rapid Adhesive Bonding of Composites
- 125 Solar-Cell-Junction Processing System
- 126 Leakproof Swaged Joints in Thin-Wall Tubing
- 127 Detecting Contaminant Particles Acoustically
- 127 Finding Brazing Voids by Holography
- 128 Electromagnetic Hammer for Metalworking
- 135 Forging Oxide-Dispersion-Strengthened Superalloys
- 135 Acoustic-Emission Weld-Penetration Monitor
- 136 Holder for Tinning Microcircuit Leads
- 137 Improvements in Ionized Cluster-Beam Deposition
- 138 Hermetic Edge Seals for Photovoltaic Modules
- 138 Television Monitoring System for Welding
- 139 Wrinkle-Free Hydroforming of Wire Mesh

Attaching Metal Fasteners to Silica Tiles

Stress is distributed so that a high load can be borne.

Lyndon B. Johnson Space Center, Houston, Texas

A bonded-plug method has been successful in attaching mechanical fasteners to porous silica refractory tiles used on the outer surface of the Space Shuttle orbiter. A fastener is bonded in a densified hole or captured in a plug of similar refractory material, which in turn is bonded in a hole in the parent tile. The plug or bonding distributes the mechanical load from the fastener to a broad region surrounding the fastener, thus reducing local stress concentration and the likelihood of breakage.

In the bonded-plug technique, a blind hole is drilled in a silica tile with a bit thirteen sixty-fourths inch (5.2 mm) in diameter. A heating coil at a temperature of 1,000° F (538° C) is inserted in the hole for 7 minutes to drive off waterproofing compound to a depth of about one-eighth inch (3.2 mm) around the hole wall.

The hole is then ready for densification. Colloidal silica is poured in the hole and allowed to stand for 5 minutes. During this time, the tile around the hole absorbs silica from the colloidal liquid. The colloidal silica is drawn off with an eyedropper. The hole is air-dried for half an hour and then dried under heat lamps at

250° ± 25° F (121° ± 14° C) for a full hour.

This densification procedure is repeated. The density of the hole wall is then 40 to 50 lb/ft³ (640 to 800 kg/m³), as compared with 22 lb/ft³ (352 kg/m³) for the bulk of the tile. Thus, the hole wall can support a greater load density than it could before densification.

A nickel-alloy insert with external and internal threads is screwed into the hole. Silica cement is injected into the inner end of the hole to a depth of one-sixteenth inch (1.6 mm) and air-dried for 24 hours to lock the insert in position. The tile can then sustain tensile loads on the insert of 29 to 45 pounds (129 to 200 N) at 1,400° F (760° C).

In the configuration shown in the figure, a floating fastener adjusts to misalignment. Load is transmitted from the fastener to the plug to the tile, the load at each interface being distributed over a larger area.

The plug is machined from 22-lb/ft³ (352-kg/m³) silica (the same material as that used for the tile). It is heat-cleaned in an oven at 1,600° F (871° C) for one-half hour. It is dipped in colloidal silica for 5 minutes. It

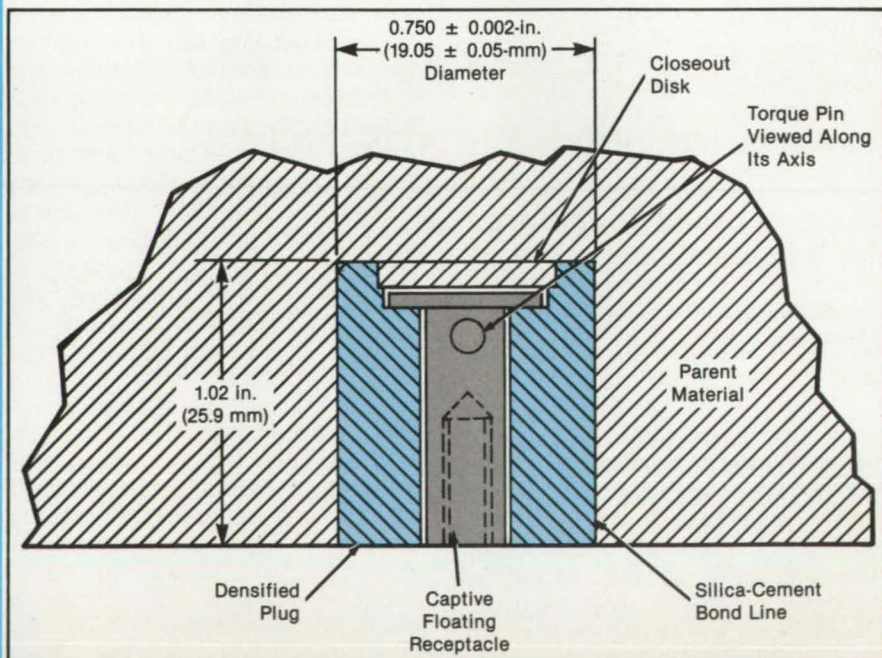

Loads Are Distributed in stages from the receptacle and the torque pin to the densified plug to the parent material. The bearing area increases at each stage.

is dried in ambient air for one-half hour, then oven-dried at 265° F (129° C) for 1 hour. Dipping and drying are then repeated. The density of the silica plug is then 40 to 50 lb/ft³ (640 to 800 kg/m³).

An internally threaded receptacle, a torque pin, and a closeout disk are inserted in the plug. The plug is bonded with

silica cement in a mating hole in a tile. The receptacle floats in the tile and can accommodate lateral misalignment of ± 0.03 in. (0.76 mm) and azimuthal misalignment of a few degrees. The tile can sustain torque loads of 60 to 90 pound-inches (6.8 to 10.2 N-m) and tensile loads of 184 to 263 pounds (532 to 818 N) on

the fastener at 1,400° F (760° C).

This work was done by Jack W. Holt, Stanley Y. Yoshino, and Laurence W. Smiser of Rockwell International Corp. for **Johnson Space Center**. For further information, Circle 67 on the TSP Request Card. MSC-20537

Compact Plasma Deposition Chamber

Contamination and nonuniformity should be reduced.

NASA's Jet Propulsion Laboratory, Pasadena, California

Substrates serve as the walls of the deposition chamber in a proposed configuration for plasma deposition of amorphous silicon. The new design reduces the requirements on chamber size and is expected to increase product quality.

In a typical glow-discharge plasma deposition process, the deposition substrates are placed on electrodes in a relatively large chamber. Since one electrode is grounded to the chamber walls, there is an electrical imbalance that favors deposition on one substrate. Also, because the chamber surfaces are an order of magnitude larger than the substrates, they both collect and emit contamination.

In the new design (see figure), with the substrates forming the two largest chamber walls, the electrical imbalance and contamination-source area would be reduced. The substrate walls will be 15 in. (38.1 cm) square and held 1 in. (2.54 cm) apart. The closeness of these walls is expected to contribute to purity by permitting

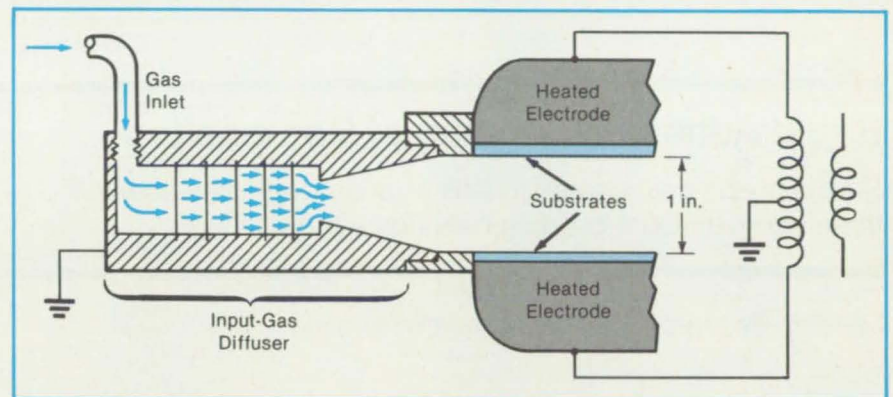

The **Deposition Substrates** serve as the two largest chamber walls. The new chamber is intended for the production of amorphous silicon solar cells.

the rapid flushing of gases. The exhaust diffuser is opposite the gas-inlet diffuser. Concave side walls close the 15 in. (38.1 cm) long by 1 in. (2.54 cm) high space between the diffusers.

This work was done by Donald B. Bickler of Caltech for **NASA's Jet Propulsion Laboratory**. For further information, Circle 5 on the TSP Request Card. NPO-16469

Lubricating Holes for Corroded Nuts and Bolts

Corroded fasteners are taken apart more easily.

Marshall Space Flight Center, Alabama

The removal of a nut rusted onto a bolt is made easier by boring small holes from three of the flats through to the thread (see figure) before the nut is used. The holes make it possible to apply lubricants and rust removers directly to more of the thread than would otherwise be reachable.

The lubricating-hole concept was tested in an experiment. Twenty 3/8-in.-24 thread carbon-steel bolts were NASA Tech Briefs, January/February 1986

placed in 20 holes in an aluminum plate. Fifteen nuts were modified with lubricating holes 3/32 in. (2.38 mm) in diameter, while five were used unmodified. All the nuts and bolts were swabbed with sea-

Lubricating Holes are bored to the thread from three of the flats. The holes facilitate the application of penetrating oil to help loosen the nut when it is rusted onto a bolt.

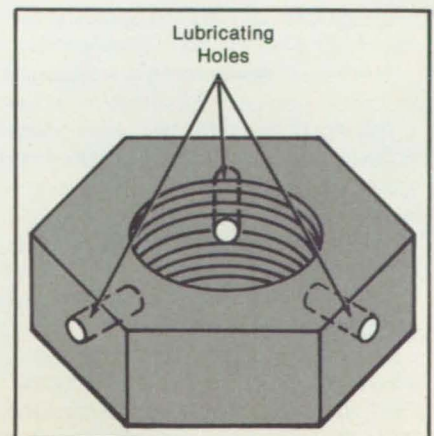

water, then assembled into the plate with washers and tightened to a torque of 20 lb-ft (27 N-m). The holes of five of the modified nuts were covered with temperature-resistant tape.

The assembly was placed in a convection oven at 90° C. At 24-hour intervals, more seawater was poured over the joints. The assembly was removed from the oven after 54 hours. After the assembly cooled to room temperature, the tape was removed. The nuts were sprayed with a commercial all-purpose lubricant, which was allowed to soak in for 30 seconds.

The amount of torque required to loosen each nut was measured (see table). The modified nuts required less torque than the others; this shows that the holes allow the lubricant to flow more effectively into the threaded joints. The table also shows that there is no advan-

Nut Condition	Loosening Torque, lb-ft					Average
No Holes	27	27	25	27	29	27
Modified	20	20	20	21	20	19.7
Modified	18	20	18	20	20	
Modified (Hole Covered)	20	20	20	20	20	20

Torques Required To Loosen nuts from bolts were measured after exposure to a corrosive seawater environment, followed by lubrication. In all cases, more torque was required to remove the nuts that did not have lubricating holes.

tage in covering the holes in a seawater environment. It may, however, be advantageous to cover the holes in the presence of particles, dusts, or powders.

This work was done by Benjamin G. Penn, Jonny M. Clemons, and Frank E. Ledbetter III of **Marshall Space Flight**

Center. No further documentation is available.

Inquiries concerning rights for the commercial use of this invention should be addressed to the Patent Counsel, Marshall Space Flight Center [see page 21]. Refer to MFS-28086.

Rapid Adhesive Bonding of Composites

Strong bonds are created in less time and with less power than if conventional bonding methods were used.

Langley Research Center, Hampton, Virginia

A rapid adhesive bonding (RAB) technique for composites uses high-frequency induction heating toroids to quickly heat a metallic susceptor impregnated with a thermoplastic adhesive or sandwiched between thermoset or thermoplastic adhesive cloths or films. The susceptor can be a steel screen or a perforated steel foil.

For lap-shear panel assemblies, the susceptor and adhesives are placed between the fiber-reinforced-plastic composite-materials to be bonded and the assembly is placed in a fixture on a machine bed. The toroids are attached to the machine carriage in such a way that a continuous uniform load is applied to the assembly under the toroid units as they pass over it. Power to the toroid heads is applied before the carriage begins its traverse of the assembly.

The toroids rapidly heat the adhesive to the bonding temperature as they pass over it. These conditions are maintained for one to several minutes to promote adherend/adhesive wetting and to effect cross-linking (cure) in thermosetting adhesives as the toroids pass each spot in the adhesive bond. After the toroids pass, the bond area rapidly cools to a temperature below which the adhesive is rigid.

The RAB equipment for overlap panel assemblies is shown in the photograph. The toroid induction heaters are mounted with a load cell on a support structure that

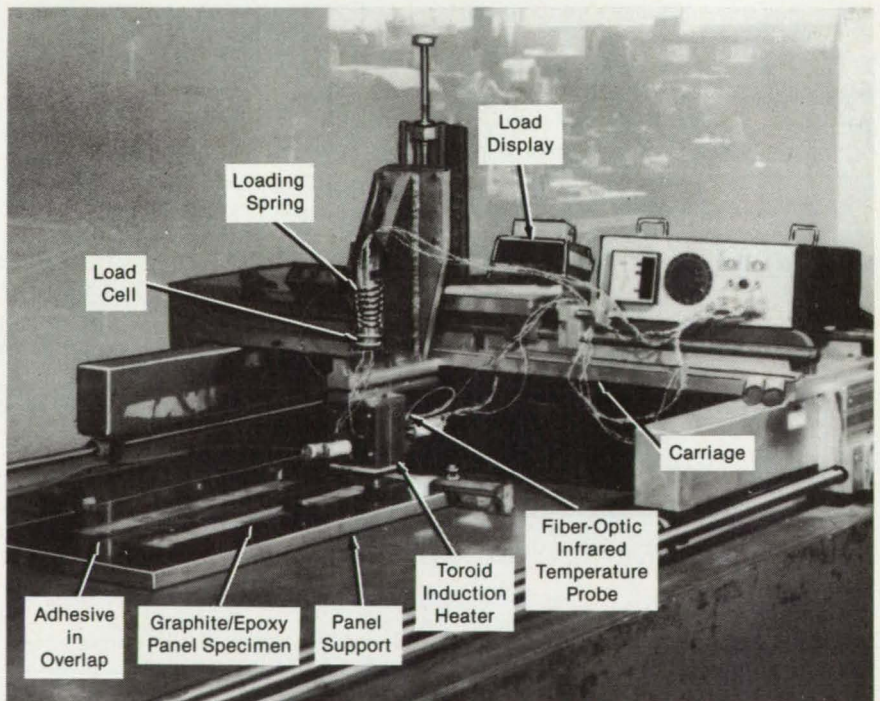

The RAB Apparatus Uses Toroid Induction Heaters with metallic susceptors for adhesive bonding.

is mounted on a transverse alignment slide. That slide is located on a longitudinal traversing carriage, which travels along a standard machine bed. The power supply, power control, and load indicators are on

the transverse slide. Thermocouple and infrared sensors monitor the panel assembly temperatures.

The panels to be bonded, 2 ft (0.61 m) long in the photograph, are located on an NASA Tech Briefs, January/February 1986

insulated panel support. Polytetrafluoroethylene boots are mounted on the bases of the toroids to enable them to slide smoothly across the surface of the parts to be bonded. The power supply, which draws approximately 300 W or less at 60 Hz and 120 V for each toroid, provides the energy for a self-tuning induction-heating circuit that operates at 30,000 to 100,000 Hz. Metallic susceptors concentrate the heat in the bond line.

Monitoring instrumentation verifies selected levels of bonding pressure and temperature. Bonding pressure is applied through the toroid head via a loading spring controlled by a manual adjustment and monitored by the load cell and its readout display. Temperature monitoring in the adhesive bond line is an important requirement of the RAB process. A commercially available fiber-optic infrared temperature probe that can monitor a very small region of the bond line from the edge of the bond is used with a special alignment feature to provide the required feedback signal.

Lap-shear specimens cut from a graphite/epoxy panel bonded with an epoxy/phenolic adhesive were tested at room temperature (RT) and at 180° F (82° C) as bonded, at RT and 180° F after 1,000 thermal cycles from -100° F (-73° C) to +180° F, and at RT and 180° F after a 72 h

boiling-water exposure. The as-bonded specimens averaged 3,940 psi (2.72×10^7 N/m²) lap-shear strength (LSS) at RT and 3,200 psi (2.21×10^7 N/m²) at 180° F compared with 2,940 and 2,970 psi (2.03 and 2.05×10^7 N/m²), respectively, for similar specimens fabricated by standard press bonding.

After thermal cycling, the RAB specimens averaged 3,640 psi LSS at RT and 3,200 psi at 180° F compared with 2,970 and 3,140 psi (2.04 and 2.16×10^7 N/m²), respectively, for standard press specimens. Therefore, the RAB process has no degrading effect on specimen shear strength compared to standard bonding, and thermal cycling does not significantly degrade these properties. The exposure to boiling water degraded bond strengths about 35 percent at RT and 28 percent at 180° F. This degradation matches that noted for the adhesive in the adhesive supplier's literature.

Successful tests were made with other materials including titanium alloy panels. Panels or structures of other geometries can be bonded by the RAB process. Examples are stiffeners or stringers on panels and repair patches. Simple fixtures would have to be designed to hold the specific geometries in place during the RAB procedure.

The type of adhesive bonding of metallic and fiber-reinforced-plastic composite structural components provided by the RAB process is particularly important because load transfer paths through mechanical fasteners, such as rivets or bolts, can cause local overloads and damage in the relatively brittle composites. "State-of-the-art" bonding with aerospace adhesives usually involves the application of heat and pressure in hydraulic presses or autoclaves. The RAB method, in contrast, is similar to spot or seam welding or seam diffusion bonding of aluminum or titanium alloy sheet.

This work was done by Bland A. Stein, James R. Tyeryar, Robert L. Fox, S. Elmo Sterling, Jr., John D. Buckley, Spencer V. Inge, Jr., Linwood G. Burcher, and Robert E. Wright, Jr., of Langley Research Center. Further information may be found in NASA TM-86256 [N84-29968/NSP], "Rapid Adhesive Bonding Concepts" [\$10]. A copy may be purchased [prepayment required] from the National Technical Information Service, Springfield, Virginia 22161.

This invention is owned by NASA, and a patent application has been filed. Inquiries concerning nonexclusive or exclusive license for its commercial development should be addressed to the Patent Counsel, [see page 21]. Refer to LAR-13277.

Solar-Cell-Junction Processing System

A system under development should reduce equipment costs.

NASA's Jet Propulsion Laboratory, Pasadena, California

A processing system under development will produce solar-cell junctions on 4 in. (10.2 cm) round silicon wafers at the rate of 10⁷ per year. The system (see figure) includes a non-mass-analyzed ion implanter, a microcomputer-controlled, pulsed-electron-beam annealer, and a wafer-transport system with vacuum interlock.

In a conventional ion implanter, the dopant phosphorus ions are focused into a beam, which is sent through a magnetic field to remove contaminant ion species having a different charge-to-mass ratio. The beam is then scanned across the wafer on two axes to make a uniform dose.

In the new ion implanter, phosphorus ions are accelerated to 10 keV in a broad, nearly uniform beam that covers the entire wafer. No magnetic beam analysis is used, and the beam is defocused and centered but not scanned: These features eliminate the large, expensive magnet and the plates, circuitry, and power source otherwise needed for scanning. In preliminary tests, solar cells produced without beam analysis performed as well

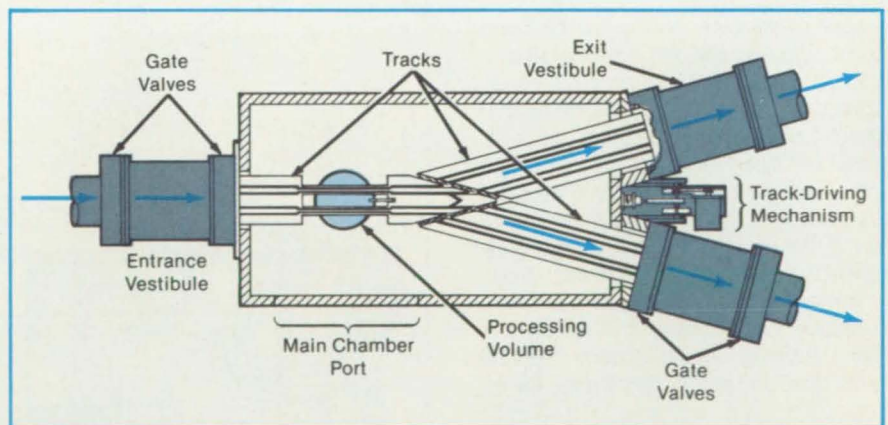

The **Solar-Cell-Junction Processing System** includes an ion implanter, an electron-beam annealer (not shown) in the processing volume, and a wafer-transport system with alternating vacuum locks.

as conventional cells.

A single pulse of electrons covering the entire wafer is used to anneal the damage caused by ion implantation. A

magnetic field to stabilize the beam is generated in an external coil and carried by a yoke to iron columns that guide it to the processing volume in the vacuum chamber. The energy for the pulse is stored in 12 high-voltage dielectric lines, each having a capacitance 2.9 nF and an inductance of 14.2 nH. The lines are joined in parallel to the trigger switch that connects them to the beam-generating diode.

The wafer-transport system is of the

walking-beam variety. The wafers ride on rails that oscillate in elliptical orbits. Several pairs of rails are out of phase with each other by an amount that results in a three-phase motion: A wafer is lifted, moved forward a small distance, and dropped onto the next rising rail pair. The wafer speed along the track is 4 in./s (10.2 cm/s).

The track-driving mechanism is located outside the vacuum. To maintain a high production rate, at least two vacuum-feed locks are needed, so that

one lock can dispense or receive wafers while the other cycles between the atmosphere and the vacuum. A Y-track switching mechanism directs the wafers along the track to one or the other lock.

This work was done by Stephen N. Bunker and Anthony J. Armini of Spire Corporation for NASA's Jet Propulsion Laboratory. For further information, Circle 28 on the TSP Request Card. NPO-16540

Leakproof Swaged Joints in Thin-Wall Tubing

Tubular inserts reinforce the joints, reducing the incidence of leaks.

Lyndon B. Johnson Space Center, Houston, Texas

Improved swaged joints in thin-wall tubing are obtained by inserting reinforcing wall thickeners in the sections to be joined. The reinforcing technique was developed for thin-wall tubing in the Space Shuttle hydraulics, and swaging has yielded poor results with such tubing. When the tube diameter is about 1 in. (2.5 cm) or more and the wall thickness is about 0.03 in. (0.76 mm) — approximately half the conventional thickness — swaged joints often leak and have to be reswaged or cut out and replaced.

In the new swaging technique, tubular inserts are placed inside the ends of both tubes to be joined (see figure). Made from thicker-wall tubing with an outside diameter that matches the inside diameter of the thin tubing to be swaged, the inserts support the tube ends at the joint. They ensure more uniform contact between the swage fitting and the tubing.

Most of the outer surface of the insert tube is removed until the outside diameter of this portion is smaller than the inside diameter of the thin-wall tube. A small lip of the full tubing thickness is left at the outer end of the insert as to aid in positioning it and to prevent it from sliding into the tube, away from the swaging area. A short portion of the insert near the lip is slightly tapered so that it fits snugly in the tubing.

The inner end of the insert is chamfered to reduce turbulence in the fluid flowing past it. Although the fitting decreases the inside diameter slightly at the joint, the effect on the flow is negligible. In fact, the fitting introduces less turbulence than a poor conventionally swaged joint.

Joints made by the new method were compared to conventional swaged joints in pressure tests. All joints were made of thin-wall tubing 1.25 in. (3.18 cm) in diameter. Conventionally swaged joints started leaking at 2,600 psi (18 MN/m²). The joints with inserts, on the other hand, had still not

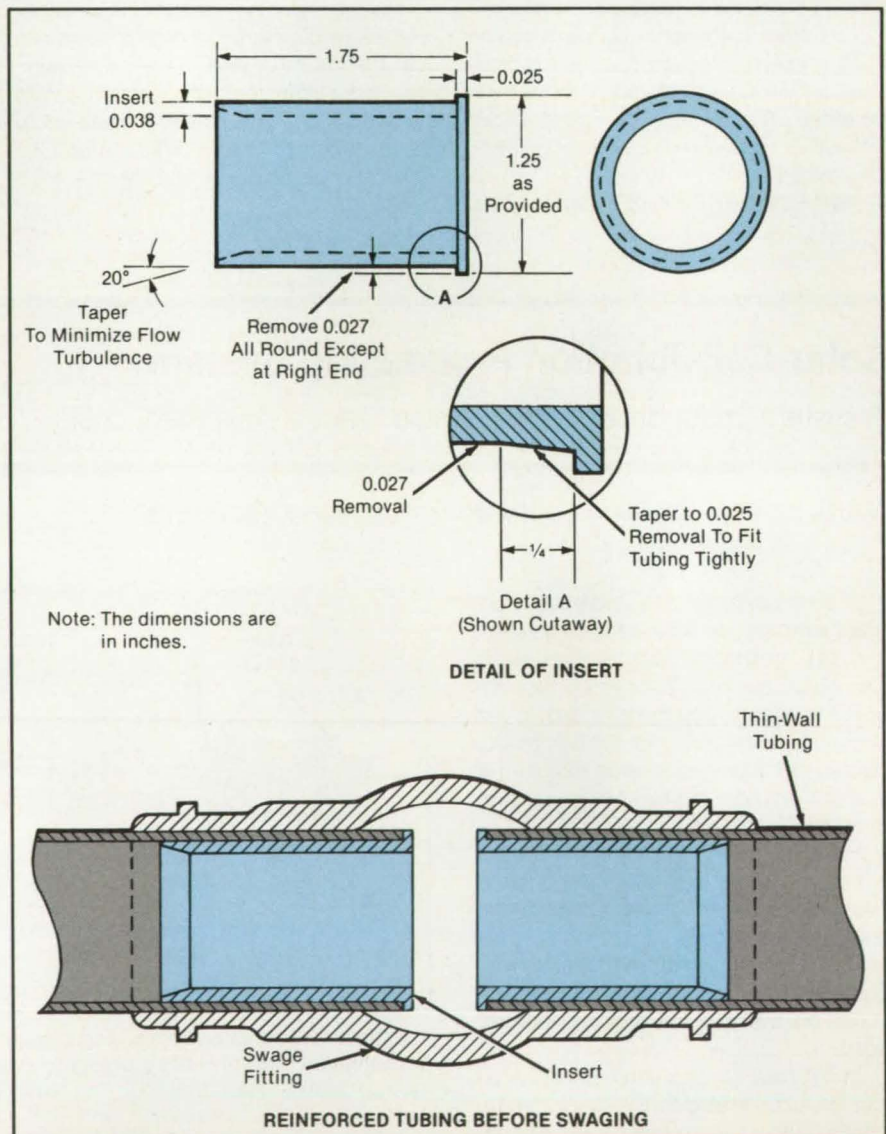

A Swage Fitting Surrounds a Joint while tubular inserts lend extra support to the tubing to be joined. By ensuring close, uniform contact between the fitting and the tubing, the inserts help to reduce leakage in the finished part. The new swaging technique was developed for Al/Ti/V-alloy hydraulic supply lines.

leaked at 5,100 psi (35 MN/m²).

This work was done by Fred H. Stuckenberg and L. K. Crockett of Rockwell International Corp. and W. E. Snyder of

Deutsch Co. for Johnson Space Center. For further information, Circle 35 on the TSP Request Card.

Inquiries concerning rights for the com-

mercial use of this invention should be addressed to the Patent Counsel, Johnson Space Center [see page 21]. Refer to MSC-20882.

Detecting Contaminant Particles Acoustically

An apparatus would "listen" for particles in the interior of complex turbomachinery.

Marshall Space Flight Center, Alabama

A proposed acoustic-resonance technique would detect such particles as machining chips in turbopumps or other machinery without disassembly of the machinery. The technique would be used after flushing with high-pressure water and inspecting with a borescope; it would reveal the presence of contaminating particles that remained after the flushing and escaped detection with the borescope.

Contact microphones would be attached at several points on the pump housing. An acoustic transducer would also be

attached to the housing to excite the entire pump with sound. The frequency of the sound would be slowly raised until the pump resonates. The microphones would then detect the noise of loose particles scraping against the pump parts.

The microphone outputs would be high-pass filtered to remove the excitation frequency. The higher frequency signals that remain would represent particle noise and would be processed and analyzed. The characteristics of the signals would reveal the locations and quantities of particles

and perhaps even the nature of the particle materials.

This work was done by Lynn M. Wyett of Rockwell International Corp. for Marshall Space Flight Center. No further documentation is available.

Inquiries concerning rights for the commercial use of this invention should be addressed to the Patent Counsel, Marshall Space Flight Center [see page 21]. Refer to MFS-29078.

Finding Brazing Voids by Holography

Vibration-induced interference fringes reveal locations of defects.

Lyndon B. Johnson Space Center, Houston, Texas

A holographic technique locates small voids in large brazed joints. The technique identifies unbrazed regions 1 in.² (6 cm²) or less in area.

An ultrasonic transducer is clamped on the object, which is then placed on an optical table for holographic evaluation (see figure). Without acoustic excitation, the object is illuminated by the object beam from the laser, while the reflected object beam and the reference beam are recorded on a photographic plate.

After the plate has been developed, the operator replaces it and views the object through it. He or she energizes the acoustic transducer and looks for optical-interference fringes, which indicate voids. The acoustic excitation frequency is adjusted between 50 and 300 kHz to vary the positions of vibration nodes and antinodes until the vibrational mode gives rise to a set of fringes that most clearly show the defects sought. The plate then is removed, and a new one is exposed to record the defect pattern.

This work was done by Richard Galluccio of United Technologies Corp. NASA Tech Briefs, January/February 1986

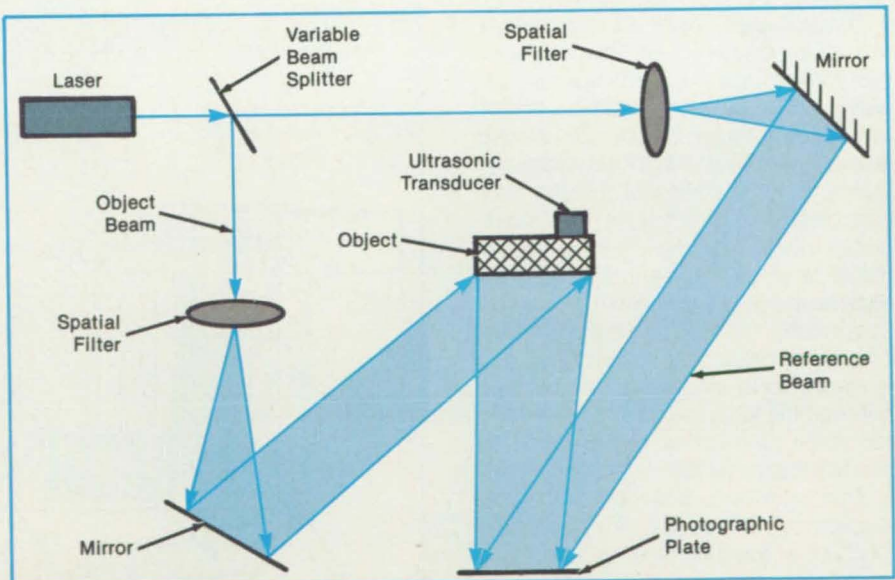

A Holographic Apparatus is used to view the object while it is vibrated ultrasonically. Interference fringes in the hologram reveal brazing defects.

for Johnson Space Center. For further information, Circle 44 on the TSP Request

Card. MSC-20495

Electromagnetic Hammer for Metalworking

High eddy currents apply pressure for cold-forming.

*Marshall Space Flight Center,
Alabama*

An electromagnetic hammer exerts momentary high pressure over a small area of a metal workpiece. In contrast with mechanical hammers, the electromagnetic hammer requires no dynamic material contact with the workpiece; consequently, it produces almost no change in the metal grain structure.

The principal elements of the hammer system are an energy-storage capacitor, a switching device, and a work coil. The capacitor is charged to a predetermined voltage, then rapidly discharged by the switching device into the coil. The current in the coil produces an intense, rapidly-changing magnetic field, which induces eddy currents in the part of the workpiece facing the coil.

The magnetic repulsion between the eddy currents and the currents in the coil is enough to deform the metal. In one version of the hammer designed for use on an aluminum tank, the currents generate pressures up to 5×10^4 psi (3.4×10^8 N/m²), which can deform the aluminum as fast as 300 m/s. The repulsive force also acts on the coil, causing it to kick back. The coil is therefore mounted in a holder (see Figure 1) that allows for this motion and makes it possible to reposition the coil simply by sliding it back toward the workpiece.

The coil (see Figure 2) is a spirally wound conductor of beryllium copper with polytetrafluoroethylene spacers between the turns. The most difficult part of fabrication is potting the coil in its housing with a heat-curing, electrical-grade polyurethane material without forming bubbles between the coil turns or in other places where insulation is essential. To minimize air entrapment, the material must be exposed to a vacuum before and after mixing, then fed into the preheated coil under pressure. After potting, the coil is inspected to insure that any bubbles between the turns or on the coil face are too small to degrade performance or shorten the useful life.

This work was done by Shirley A. Anderson, F. Brunet, A. Dowd, R. Durham, J. Ezell, G. Gorr, D. Hartley, F. Jackson, J. Marchand, W. MacFarlane, P. Nameth, K. O'Kelly, H. Phillips, J. Rollo, E. Rupert, H. Sykes, E. Vitrano, and M. Woods of Martin Marietta Corp. for Marshall Space Flight Center. For further information, Circle 66 on the TSP Request Card. MFS-27096

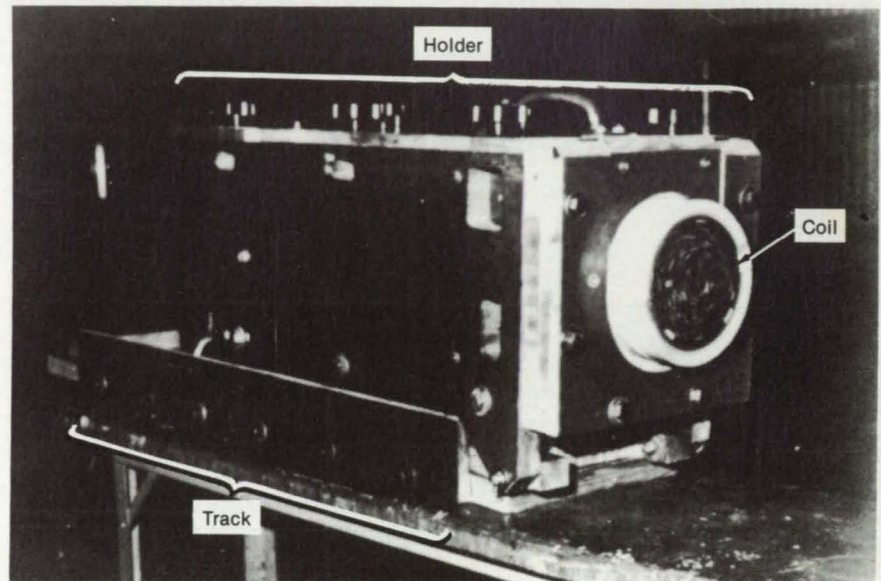

Figure 1. The **Coil Face Protrudes** from the sliding toolholder. When activated, the hammer recoils along the short track.

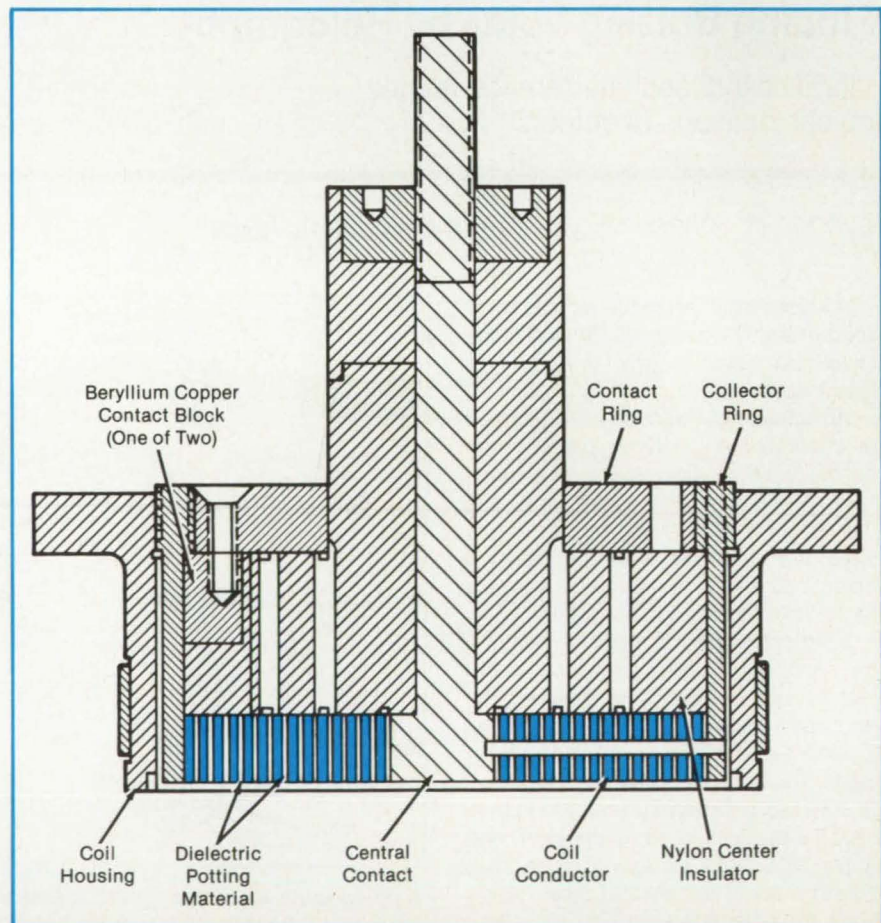

Figure 2. The **Coil Housing** is constructed for mechanical strength to hold the coil against the magnetic force, to maintain electrical contact with the coil ends, and to maintain insulation between coil turns. The drilled holes are placed to facilitate the release of bubbles during potting.

Multiple Pages Intentionally Left
Blank

Forging Oxide-Dispersion-Strengthened Superalloys

A cladding of mild steel prevents surface cracking when the alloy contacts the die.

Lewis Research Center, Cleveland, Ohio

There is a continual need for improvements in the properties of alloys capable of withstanding elevated temperatures. This can be accomplished by using oxide-dispersion-strengthened superalloys such as Inconel® Alloy MA 6000. This alloy is made from mechanically alloyed powders, extruded, hot-rolled into bar stock, and directionally recrystallized. Its microstructure consists of large grains, greatly elongated in the rolling direction. Its properties combine typical superalloy strength at intermediate temperatures [about 1,400° F (760° C)] with superior strength at high temperatures [about 2,000° F (1,100° C)] and make it attractive for turbine-blade applications (see figure).

However, with directionally recrystallized material, it is necessary to machine turbine blades from bar stock, which results in much waste of a quite expensive material. Attempts to forge the fully processed material resulted in a nonreversible loss of mechanical properties.

An approach was therefore developed to take advantage of the ultrafine-grained microstructure of MA 6000 by forging it in the unrecrystallized state. To accomplish this, it was necessary to prevent surface cracking of the material by thermal shock when it came in contact with the forging dies. This was achieved by encasing the alloy in an adherent cladding of mild steel as provided by the original extrusion can or a thick plating. These clad-forging blanks were then coated with a commercial glass lubricant.

A forging temperature between 1,850° and 1,950° F (1,010° and 1,065° C) yields the proper elongated grain structure in the subsequent directional recrystallization heat treatment. The deformation level is



FORGED ODS TURBINE BLADE BLANK



GRAIN STRUCTURE OF ODS TURBINE BLADE

Turbine Blades can be strengthened for high-temperature performance by use of forged oxide-dispersion-strengthened (ODS) superalloys. An ODS turbine-blade blank is shown on the left; the grain structure of the ODS turbine blank is shown on the right.

not critical. The die design must allow for the additional thickness of the cladding and should avoid sharp transition areas to promote the formation of a continuous elongated grain structure during recrystallization.

The elevated tensile properties of the forged alloy equal those of the hot-rolled MA 6000 bar. The stress-rupture properties are somewhat lower than those of the bar stock but, at 1,100° C, exceed those of the strongest commercial single crystal, directionally solidified and conventionally cast superalloys.

(Inconel® is a registered trademark of the Inco family of companies.)

This work was done by F. H. Harf and T. K. Glasgow of **Lewis Research Center** and D. J. Moracz and C. M. Austin of TRW, Inc. Further information may be found in NASA CR-174650 [N84-25711/NSP], "Fabrication Development for ODS-Superalloy, Air-Cooled Turbine Blades" [\$13]. A copy may be purchased [prepayment required] from the National Technical Information Service, Springfield, Virginia 22161. LEW-14179

Acoustic-Emission Weld-Penetration Monitor

Sounds could be used to control robotic welders.

Marshall Space Flight Center, Alabama

Weld penetration can be monitored by the detection of high-frequency acoustic emissions produced by the advancing NASA Tech Briefs, January/February 1986

weld pool as it melts and solidifies in the workpiece. Such monitoring could be applied to the control of automated and ro-

botic welders.

Experiments in tungsten/inert gas (TIG) welding have shown a clear correlation

between the depth of penetration and the level of acoustic emission (see figure). The coupling of an acoustic-emission monitor to the controller of an automatic or robotic welder could allow real-time adjustment of weld parameters (for example, arc current and travel speed), yielding optimal weld penetration. The measurement of the acoustic emissions could be made with such contact probes as piezoelectric transducers or, more effectively, with such noncontact probes as optical vibrometers or electromagnetic sensors that could travel with the welding head during the welding operation.

This work was done by Jonathan Maram and John Collins of Rockwell International Corp. for Marshall Space Flight Center. For further information, Circle 64 on the TSP Request Card. MFS-29064

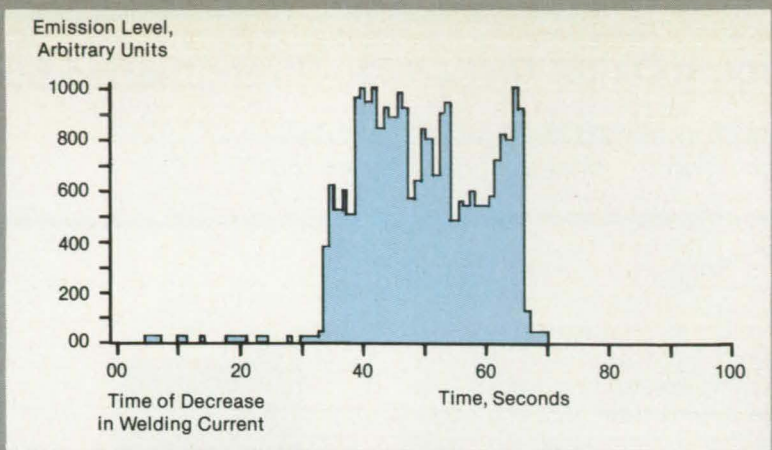

The Acoustic Emission From a TIG Butt Weld was measured with a 300-kHz resonant transducer. The rise in the emission level coincides with the cessation of weld penetration due to a sudden reduction in welding current.

Holder for Tinning Microcircuit Leads

Tool ensures that leads are tinned adequately but not excessively.

Lyndon B. Johnson Space Center, Houston, Texas

A heat-sinking tool holds microcircuits for lead tinning while protecting the circuits from the heat of the tinning solder. The application for which the tool was originally developed requires that the tinning not be closer than 0.02 in. (0.5 mm) from the package body or its glass seals.

As shown in Figure 1, the tool includes a small, two-part box that holds the microcircuit with the leads to be tinned protruding from the gap between the box halves. The box is fastened to the ends of a pair of tweezers, which squeeze them together around the microcircuit. The tweezers are the "normally closed" type.

An operator inserts a microcircuit in the box and allows the halves to clamp around the microcircuit. Soldering flux is then applied to the leads with an acid brush. The leads and the bottom of the tool are then rotated through the solder wave or pot (see Figure 2) with approximate timing as follows:

- One second to insert the leads into the solder,
- Two seconds to hold in the solder, and
- Two seconds to withdraw the leads from the solder.

The direction of rotation is important: The tool is moved so that the knees of the

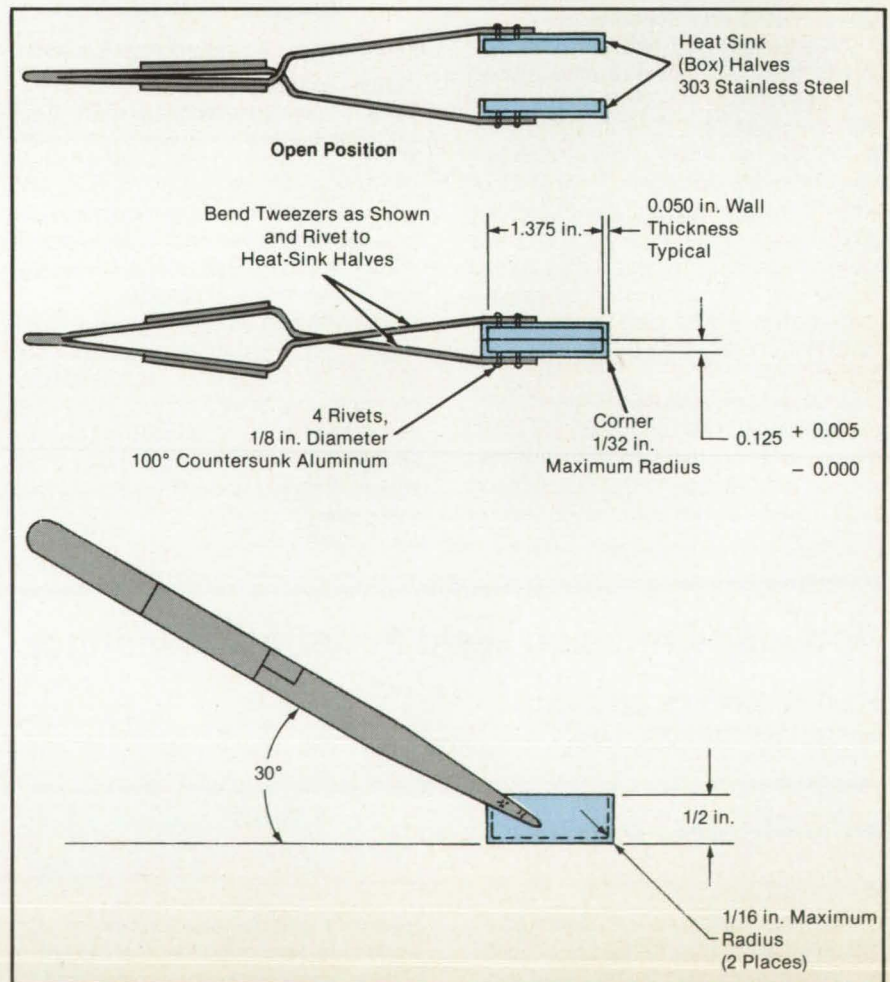

Figure 1. The Heat-Sinking Tool is made from a 6-in. (15.2-cm) pair of tweezers and a small hollow heat sink, each half of which is attached to a tweezer arm.

leads are ahead; otherwise, the leads will scoop up too much solder. After tinning, the tool and circuit are dipped in Freon TES (or equivalent) cleaning solvent to remove the flux and cool the parts. The circuit is then inverted in the tool and the process repeated to tin the leads on the opposite side.

This work was done by Gary G. Gilbert and George Dehnert Fielder of Sperry Rand Corp. for **Johnson Space Center**. No further documentation is available.

Inquiries concerning rights for the commercial use of this invention should be addressed to the Patent Counsel, Johnson Space Center [see page 21]. Refer to MSC-20662.

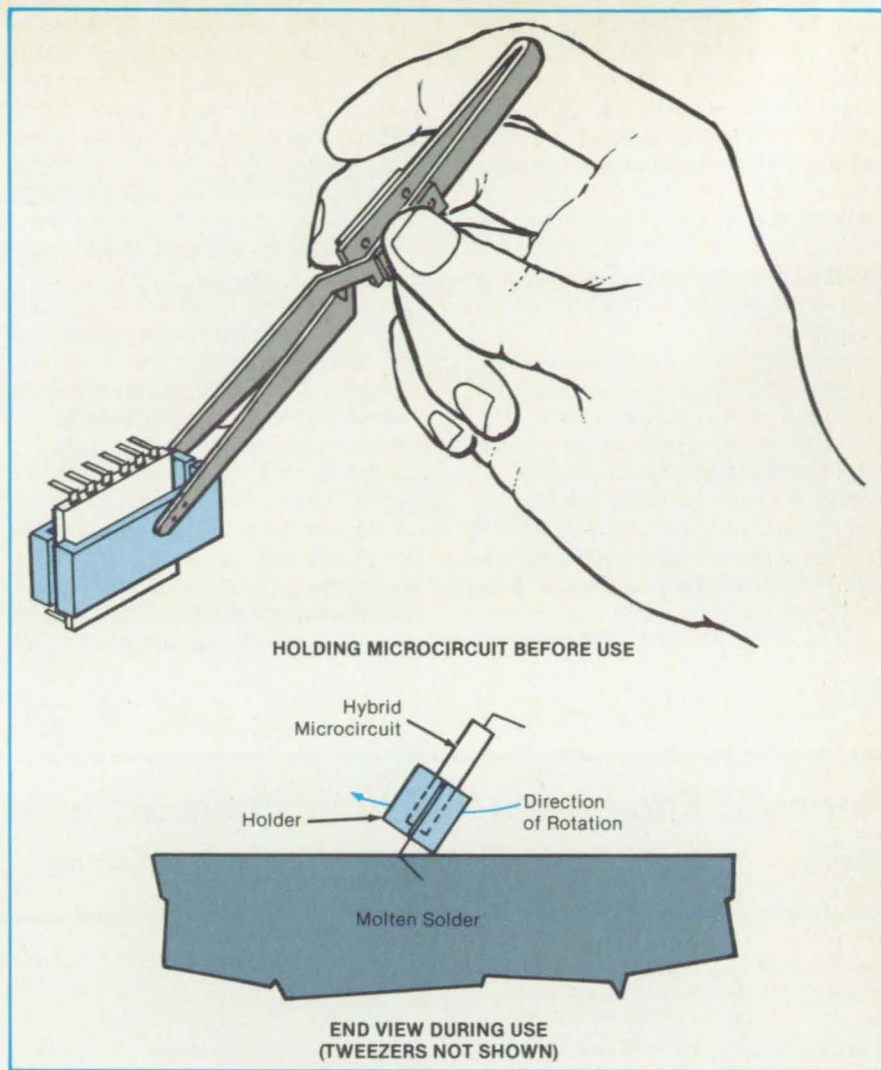

Figure 2. The **Microcircuit Holder** dips the leads in molten solder. The holder shields the microcircuit from the solder heat while the leads are immersed and absorbs heat conducted through the leads. It thus keeps the microcircuit relatively cool.

Improvements in Ionized Cluster-Beam Deposition

Lower temperatures would result in higher purity and fewer equipment problems.

NASA's Jet Propulsion Laboratory, Pasadena, California

Proposed improvements in the ionized cluster-beam deposition of semiconductor or other thin films would exploit the chemical reactivities and volatilities of selected reactants and resulting reaction products to enhance film properties.

The conventional cluster-beam technique typically requires high temperatures to vaporize the elements to be deposited (about 2,500 K for silicon). Such temperatures also cause vaporization of beam source materials of construction (for example, carbon), which become trapped in the beams and are incorporated into the thin films as contaminants. High temperatures also entail difficult problems of furnace design, heat shielding, measurements of vapor pressure

and temperature, and the costs of the foregoing. The improved technique would eliminate these problems by using reactive gaseous compounds, which are volatile at much lower temperatures.

In cluster-beam deposition, clusters of atoms are formed by the adiabatic expansion of a vaporized material into a vacuum. With the proper choice of pressure and temperature upstream of the expansion nozzle and with proper nozzle design, the expanding vapor cools sufficiently to become supersaturated and form clusters of the material to be deposited. The clusters are ionized and accelerated in an electric field and then impacted on a substrate where the films are formed.

If gaseous compounds of thin-film ma-

terials are used instead of the pure elements, the temperatures required to achieve adequate vapor pressures are reduced. Gases that lend themselves well to this improved technique include phosphine, arsine, germane, silane, and the metal halides. These compounds have vapor pressures sufficiently high to allow cluster formation at temperatures of only 200 to 300 K.

The source for a volatile-gas cluster beam is essentially a stagnation chamber with a nozzle and with flow and pressure controls. Temperature control is not as critical as in the conventional technique because stagnation pressure is established by mass flow instead of by vapor-pressure equilibrium. To the degree to

which temperature control might be required, it is much easier at the lower temperatures.

Impurity levels in the deposited films would depend on the purities of the reactant gases, background vacuum constituents, and the retention of the volatilizing elements (e.g., hydrogen from silane remaining in a silicon film). Several approaches have been proposed to control the concentration of the volatilizing species.

In one version, the reactant compound(s) would be exposed to an electrical discharge or ultraviolet radiation just upstream of the nozzle to generate a polymolecular gas before the clusters are formed. For example, some of the bonds of a hydride would be broken to form a distribution of molecular fragments having different hydrogen contents. Due to the higher supersaturation of the molecules lower in hydrogen, clusters rich in

the elements to be deposited would be formed. The nonsupersaturated constituents, including molecular hydrogen, would aid the clustering process by carrying off part of the latent heat of condensation. The deposit would be rich in the volatilizing element, and this version would therefore be useful when the volatilizing element would be beneficial; for example, when hydrogen is needed to cap dangling bonds in silicon.

Another approach would use reactive gas mixtures that are stable under clustering conditions. After being ionized and accelerated to several electronvolts per molecule, the gas clusters have sufficient energy to initiate the mixture reaction upon collision with the substrate. For example, silane and chlorosilane would react in this way to deposit silicon and evolve volatile hydrogen chloride gas. In a third approach, a pure hydride (e.g., silane) would simply be accelerated to such

an energy that impact alone would cause the desired element to be deposited and the volatilizing element (hydrogen) to be set free.

The improved cluster-beam technique might be useful for the deposition of refractory metals. An additional elaboration of the basic technique might be the merging of two or more beams to deposit films of more than one element. Another variation might be to put a dopant gas into the vacuum chamber at a low background pressure so that some of the dopant becomes entrained in the beam and deposits in the film.

This work was done by Dennis J. Fitzgerald, Leslie E. Compton, and Eugene V. Pawlik of Caltech for NASA's Jet Propulsion Laboratory. For further information, Circle 68 on the TSP Request Card.

NPO-16518

Hermetic Edge Seals for Photovoltaic Modules

Corrosive atmospheric agents are excluded to prolong cell life.

NASA's Jet Propulsion Laboratory, Pasadena, California

A combination of two sealing techniques makes it possible to protect solar cells from water vapor, oxygen, and other corrosive atmospheric constituents. Using a three-step process, a glass-to-metal hermetic seal is formed around the edge of a solar-cell module. The elastomer seals that were used previously are not as effective because they are permeable to water vapor and atmospheric gases.

First, electrostatic bonding is used to attach an aluminum-foil gasket to the pe-

rimeter of the glass cover sheet of the module. Electrostatic bonding is a field-assisted process in which free oxygen ions in the glass chemically bond to the foil, forming a thin aluminum oxide layer at the interface. The process requires a temperature of about 350° C.

The module is then encapsulated behind the glass in a standard laminating or casting process. Since the gasket is already in place, it is not necessary to expose the module to damage by the high

bonding temperature.

A back cover of aluminum foil is bonded to the aluminum-foil gasket by ultrasonic welding. This step completes the hermetic seal without heating the module excessively.

This work was done by Michael J. Nowlan of Spire Corp. for NASA's Jet Propulsion Laboratory. For further information, Circle 62 on the TSP Request Card.

NPO-16427

Television Monitoring System for Welding

The welding process in visually inaccessible spots is viewed and recorded.

Marshall Space Flight Center, Alabama

A television system enables the monitoring of welding in visually inaccessible locations. The system can assist welding operations and provide a video record, which can be used for weld analysis and for welder training.

The optical image of the arc and weld

puddle is transmitted to a 3- by 3- by 2-in. (7.6- by 7.6- by 5.1-cm) charge-injection imaging-device camera via a bundle of optical fibers, a lens, and a filter. The flexible fiber-optic cable can be mounted directly on the welding head. A motorized filter wheel enables the remote selection

of the appropriate filter (for example, to reduce the glare from the arc, thereby producing a clearer image of the welding process). The system includes a compatible television monitor.

This system allows visual access to many areas not accessible to conventional welding techniques. For further information, Circle 64 on the TSP Request Card.

NASA Tech Briefs, January/February 1986

tional optical equipment: For example, it can be used in a titanium weld booth and (with an added light source) to view the back side of a weld to see the penetration during welding.

This work was done by Karen Vallow and Steve Gordon of Rockwell International Corp. for Marshall Space Flight Center. For further information, Circle 103 on the TSP Request Card. MFS-29104

Wrinkle-Free Hydroforming of Wire Mesh

Plastic films lubricate the workpiece so that it deforms smoothly.

Marshall Space Flight Center, Alabama

A new method of hydroforming fine-wire-mesh heat-shield screens eliminates wrinkles and marks. The new method thus prevents a screen from being damaged and its pores from becoming blocked.

In the new method, thin sheets of a plastic such as polytetrafluoroethylene are molded in the same shape as that of the screen to be formed, and are inserted between the screen material and the upper and lower dies before hydroforming

(see figure). The sheets reduce friction and allow the screen to slide more freely between the dies during hydroforming. The screen thus accommodates readily to the shapes of the dies without folding or excessive stretching.

This work was done by John Fadness of Rockwell International Corp. for Marshall Space Flight Center. No further documentation is available. MFS-29111

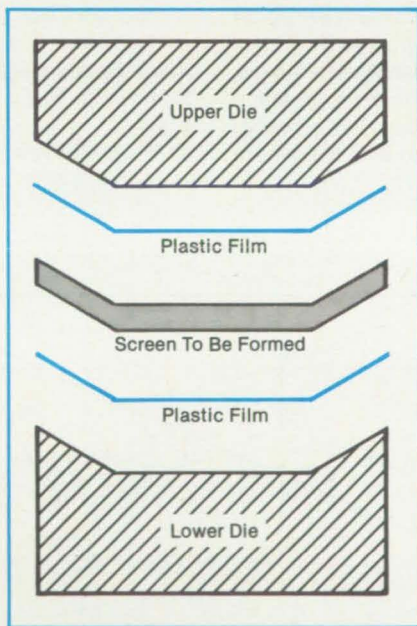

Thin Layers of Plastic below the top die and above the bottom die ensure that a wire screen slides as it is shaped by hydroforming. The plastic layers are 0.0043 in. (0.11 mm) thick. They are preformed to the contours of the dies and the final workpiece.

You're never too old to quit blowing smoke.

No matter how long or how much you've smoked, it's not too late to stop. Because the sooner you put down your last cigarette, the sooner your body will begin to return to its normal, healthy state.

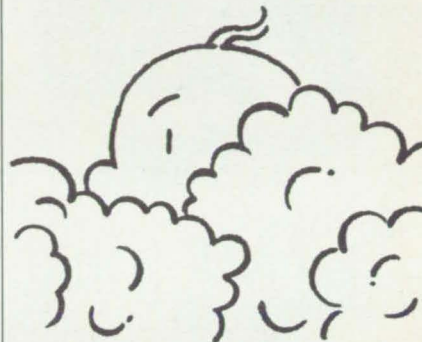

American Heart Association
WERE FIGHTING FOR YOUR LIFE

New! Metal Spring/PTFE Seals With Unique Dual-Lip Design For Double Leak Protection

Greene, Tweed MSE™ Series F are the only metal spring/PTFE seals with two lips to offer double leak protection and trap lubricant for longer life. These low-friction, self-lubricating seals for rod, piston and face sealing applications—

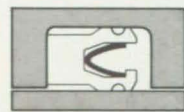

- Provide excellent static and dynamic sealing at pressures to 10,000 psi.
- Operate at temperatures from cryogenic to 500F+.
- Fit MIL-G-5514F glands.
- Are compatible with aggressive aerospace fluids, and are non-contaminating.

MSE seals are available in a variety of PTFE's and spring energizers; they are ideal for applications in fuel systems, emergency blow down systems, electronic cooling systems, etc.

Call or write for details.

GREENE, TWEED & CO

North Wales, PA 19454 • USA • (215) 256-9521

Mathematics & Information Services

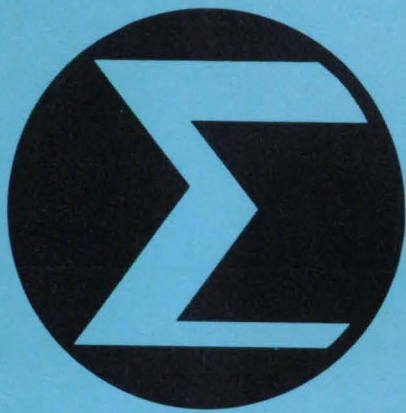

Hardware, Techniques, and Processes

140 Derivatives of the Arithmetic-Geometric Mean

Derivatives of the Arithmetic-Geometric Mean

Electrostatic fields in clouds are estimated more precisely.

Marshall Space Flight Center, Alabama

A mathematical technique enables the computer evaluation of derivatives of the arithmetic-geometric mean. Developed for theoretical studies of lightning requiring estimates of electric fields in clouds, the technique is expected to reduce computation time and improve accuracy.

For estimating purposes, a cloud is treated as having a cylindrical shape, and the electrical charge in the cloud is modeled as an array of charged circular hoops. The electrostatic potential of this charge distribution observed at a specified location is calculated as the sum of the potentials at that location arising from the individual hoops.

The arithmetic-geometric mean is a function that appears in the denominator of the expression for the hoop potential. It incorporates the effects of the hoop radius and the distance and direction from the center of the hoop to the observation point (see figure). The arithmetic-geometric mean represents, in effect, a fictitious distance, g : The potential at the observation point equals the potential that would be observed at a distance g

from a point charge of magnitude equal to the charge on the hoop.

Since the electric field is just the negative gradient of the potential, the calculation of the electric field at a point requires the calculation of derivatives of the arithmetic-geometric means of the hoops. Using the geometry of the figure, the derivatives needed to calculate the electric field are $\partial g/\partial r$ and $\partial g/\partial z$.

The procedure for numerically evaluating these derivatives by computer is analogous to that for evaluating the arithmetic-geometric mean itself. It involves successive approximations based on derivatives of the arithmetic mean and of the geometric mean obtained from the preceding approximation. As in the case of the arithmetic-geometric mean itself, the procedure for the derivatives converges rapidly.

This work was done by Frank B. Taton of Engineering Analysis, Inc., for Marshall Space Flight Center. For further information, Circle 83 on the TSP Request Card.

MFS-26018

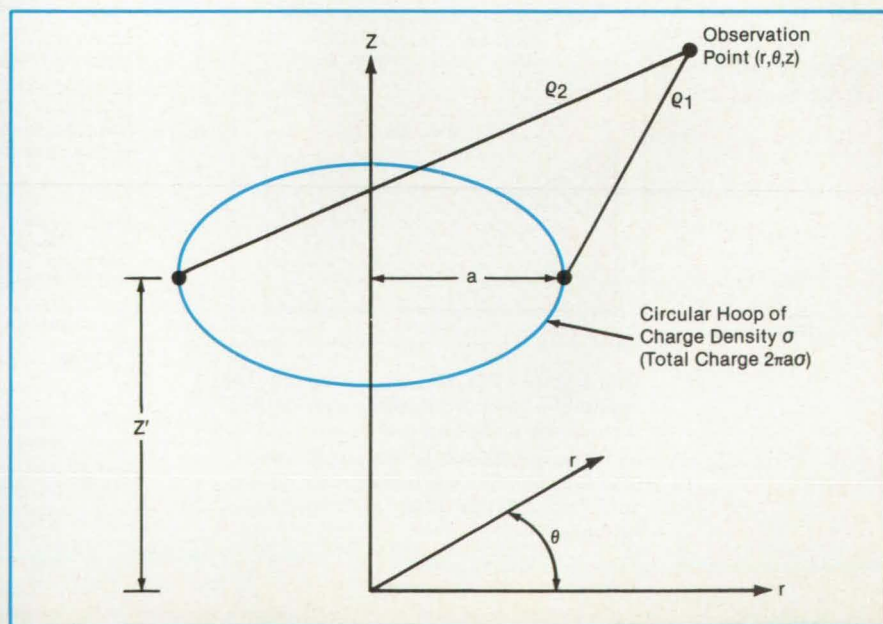

The **Arithmetic-Geometric Mean** is a fictitious radius with magnitude between e_1 and e_2 . It expresses the spatial dependence of the electrostatic potential arising from the hoop of charge.

W

hen You Fly With . . .

YOUNG, CRIPPEN, ENGLE, TRULY, LOUSMA,
FULLERTON, MATTINGLY, HARTSFIELD, ALLEN, BRAND
OVERMYER, LENOIR, THORNTON, WILLIAMS,
PETERSON, WEITZ, BOBKO, MUSGRAVE, FABIAN,
HAUCK, RIDE, THAGARD, GARDNER, BLUFORD,
THORNTON, BRANDESTAIN, MERBOLD, SHAW,
PARKER, YOUNG, GARRIOTT, LICHTENBERG, GIBSON
McCANDLESS, McNAIR, STEWART, HART, NELSON,
VAN HOFTEN, SCOBEE, COATS, MULLANE,
HAWLEY, RESKIN, WALKER, SULLIVAN, HOFFMAN,
LESSTMA, McBRIDE, GARNEAU, SCULLY, WANG,
POWER, FISHER, GARDNER, HAUCK, PAYTON,
ONIZUKA, BUCHLI, LIND, GREGORY, VAN DEN BERG
SEDDON, GRIGGS, BAUDRY, SHRIVER AND GARN.

YOU BETTER HAVE THE RIGHT STUFF.

DATATAPE, THE RECORDER COMPANY PROVEN
TO HAVE THE RIGHT STUFF WHEN YOU NEED IT.

DATATAPE
INCORPORATED
A KODAK COMPANY
Circle Reader Action No. 340





A

ABERRATION
Test method for X-ray telescopes
page 75 MFS-26020

ABSORPTION SPECTROSCOPY
Brewster-plate spoiler for laser spectrometers
page 72 NPO-16567

ACOUSTIC EMISSION
Acoustic-emission weld-penetration monitor
page 135 MFS-29064

ADHESIVE BONDING
Rapid adhesive bonding of composites
page 124 LAR-13277

AERODYNAMIC DRAG
Combined devices for turbulent-drag reduction
page 94 LAR-13286

AEROSPACE VEHICLES
Plasma source for charge control
page 68 NPO-16576

AIR CONDITIONING EQUIPMENT
Heat pipe precools and reheats dehumidified air
page 111 KSC-11311

AIRCRAFT SAFETY
Ice detector for aircraft
page 100 LAR-13403

ALIGNMENT
Laser holder aids centering of X-ray head
page 104 MFS-29067

ALLOYS
Low-gravity alloy studies on aircraft
page 80 MFS-25967

ANTENNA ARRAYS
Calculating directivities of planar-array antenna feeds
page 51 NPO-16505

ANTENNA RADIATION PATTERNS
Microstrip antenna generates circulatory polarized beam
page 32 NPO-16460

ANTENNAS
Microwave antenna with reduced noise leakage
page 48 NPO-15785

ARC WELDING
Television monitoring system for welding
page 138 MFS-29104

ARRESTERS
Emergency brake for tracked vehicles
page 118 MSC-20513

ATMOSPHERIC ELECTRICITY
Derivatives of the arithmetic-geometric mean
page 140 MFS-26018

AUXILIARY POWER SOURCES
Portable hydraulic power pack
page 115 KSC-11318

AXIAL COMPRESSIVE LOADS
Self-aligning end supports for energy absorber
page 94 LAR-13295

B

BODY TEMPERATURE (NON-BIOLOGICAL)
Graphical method for predicting steady-state temperature
page 100 MSC-20835

BOLTS
Internally wrenching nut
page 93 MFS-29068

BOLTS
Optimized bolted joint
page 103 LAR-13250
Lubricating holes for corroded nuts and bolts
page 123 MFS-28086

BONDING
A rapid attachment of strain gages
page 98 LAR-13237

Rapid adhesive bonding of composites
page 124 LAR-13277

BRAKES (FOR ARRESTING MOTION)
Emergency brake for tracked vehicles
page 118 MSC-20513

BRAZING
Finding brazing voids by holography
page 127 MSC-20495

BRUSHES (ELECTRICAL CONTACTS)
Brush-type connectors for thermoelectric elements
page 44 NPO-16545

C

CABLES
Manual "guillotine" wirecutter
page 110 MSC-20926

CAMERAS
Easily accessible camera mount
page 99 KSC-11316

CARGO
Cradles for support in transit
page 92 MSC-20725

CASES (CONTAINERS)
Secure disposal container for classified papers
page 120 NPO-16517

CHARGE COUPLED DEVICES
Reducing dark currents in charge-coupled devices
page 38 NPO-16150

CHARGE TRANSFERS
Simulating single-event upsets in bipolar RAM's
page 67 NPO-16491

CHEMICAL EQUILIBRIUM
Thermodynamic calculators for complex chemical mixtures
page 79 LEW-14166

CHEMICAL PROPULSION
Portable hydraulic power pack
page 115 KSC-11318

CHIPS (ELECTRONICS)
Detector arrays with image-plane processing
page 60 LAR-13391

CIRCUIT BOARDS
Flex circuitry for confined spaces
page 52 MSC-20773

CIRCULAR POLARIZATION
Microstrip antenna generates circulatory polarized beam
page 32 NPO-16460

CLOUDS
Derivatives of the arithmetic-geometric mean
page 140 MFS-26018

COAL
A manifold coal-slurry haulage system
page 110 NPO-16471

COATINGS
Colorless polyimides containing phenoxy-linked diamines
page 87 LAR-13353

COBALT ALLOYS
Low-cobalt powder-metallurgy superalloy
page 84 LEW-14113

COMMUNICATION EQUIPMENT
Microwave antenna with reduced noise leakage
page 48 NPO-15785

COMPOSITE MATERIALS
Rapid adhesive bonding of composites
page 124 LAR-13277

COMPOSITION (PROPERTY)
Computing composition/depth profiles from X-ray diffraction
page 78 LAR-13356

COMPUTERIZED SIMULATION
Simulating single-event upsets in bipolar RAM's
page 67 NPO-16491

COMPUTERS
Hardware/software expansion of display terminal and CPU
page 65 LAR-13350

CONDENSERS (LIQUIFIERS)
Multileg heat-pipe evaporator
page 109 MSC-20812

CONTAINERLESS MELTS
Making high-porosity alloy spheroids
page 85 MFS-25997

CONTAMINANTS
Detection of machining chips by pressure-reversal
page 114 MFS-29076

Detecting contaminant particles acoustically
page 127 MFS-29078

Reducing sodium contamination in MOS devices
page 86 MFS-28034

CONTROL VALVES
Dual-flow-rate valve
page 116 MSC-20849

Variable-displacement hydraulic drive unit
page 121 MSC-20728

CONTROLLERS
Digital controller for remote manipulator
page 114 NPO-16470

COOLING SYSTEMS
Heat pipe precools and reheats dehumidified air
page 111 KSC-11311

CORONAS
Pulsed-corona electrostatic charger
page 50 NPO-16523

CORROSION
Lubricating holes for corroded nuts and bolts
page 123 MFS-28086

CRANES
Oscillation damper with spring assist
page 116 NPO-16223

CURING
Monitoring prepregs as they cure
page 82 LAR-13335

CUTTERS
Manual "guillotine" wirecutter
page 110 MSC-20926

D

DATA CONVERTERS
Pseudolog digital-to-analog converter
page 65 LEW 14219

DEICING
Ice detector for aircraft
page 100 LAR-13403

DEPOSITION
Compact plasma deposition chamber
page 123 NPO-16469

Improvements in cluster-beam deposition
page 137 NPO-16518

DIGITAL COMMAND SYSTEMS
Digital controller for remote manipulator
page 114 NPO-16470

DIGITAL FILTERS
Integrated-circuit active digital filter
page 62 NPO-16020

DIGITAL TO ANALOG CONVERTERS
Pseudolog digital-to-analog converter
page 65 LEW-14219

DIRECTIONAL ANTENNAS
Microstrip antenna generates circulatory polarized beam
page 32 NPO-16460

Calculating directivities of planar-array antenna feeds
page 51 NPO-16505

DISCONNECT DEVICES (LIQUIFIERS)
Reliable one-shot separation of connectors
page 52 MSC-20839

DISPLAY DEVICES
Hardware/software expansion of display terminal and CPU
page 65 LAR-13350

DISPOSAL
Secure disposal container for classified papers
page 120 NPO-16517

DISTRIBUTION (PROPERTY)
Computing composition/depth profiles from X-ray diffraction
page 78 LAR-13356

DIVING (UNDERWATER)
Self-contained neutral-buoyancy suit
page 90 MSC-20424

DRAG REDUCTION
Combined devices for turbulent-drag reduction
page 94 LAR-13286

E

EARTH RESOURCES
Multispectral infrared images of terrain
page 69 NPO-16295

ELECTRIC ARCS
Rotating drive for electrical-arc machining
page 120 MFS-19946

ELECTRIC CONNECTORS
Brush-type connectors for thermoelectric elements
page 44 NPO-16545

Reliable one-shot separation of connectors
page 52 MSC-20839

Rotary joints with electrical connections
page 117 NPO-16250

ELECTRIC DISCHARGES
Plasma source for charge control
page 68 NPO-16576

ELECTRIC WIRES
Manual "guillotine" wirecutter
page 110 MSC-20926

ELECTRIC WIRING
Flex circuitry for confined spaces
page 52 MSC-20773

ELECTROMAGNETIC HAMMERS
Electromagnetic hammer for metal-working
page 128 MFS-27096

ELECTROSTATIC CHARGE
Pulsed-corona electrostatic charger
page 50 NPO-16523

ENVIRONMENTAL CONTROL
"Curtainless" Window
page 119 MSC-18417

ENVIRONMENTAL TESTS
Simplified ride-comfort program
page 107 LAR-13289

EVAPORATORS
High-performance heat pipe with screen mesh
page 101 MSC-20497

Multileg heat-pipe evaporator
page 109 MSC-20812

EXCIMER LASERS
Timed-multiple-laser array
page 58 NPO-16433

EXTENSOMETERS
Clip-on extensometer
page 96 MSC-20710

F

FASTENERS
Attaching metal fasteners to silica tiles
page 122 MSC-20537

FASTENERS
Internally wrenching nut
page 93 MFS-29068

FIELD EFFECT TRANSISTORS
Submicron silicon MOSFET
page 40 NPO-16601

FLIGHT SIMULATORS
In-flight simulator for IFR training
page 56 KSC-11218

FLOW RESISTANCE
Precise conductance valve insert
page 97 LAR-13340

FORGING
Forging oxide-dispersion-strengthened superalloys
page 135 LEW-14179

FREQUENCY CONVERTERS
Intermediate-frequency-to-video-band converter
page 64 NPO-16214

G

GALLIUM ARSENIDES
Buried-dielectric-microstrip network
page 42 LAR-13285

GALLIUM PHOSPHIDES
Improved solar-cell tunnel junction
page 53 NPO-16526

GAS FLOW
Precise conductance valve insert
page 97 LAR-13340

GAS TUNGSTEN ARC WELDING
Acoustic-emission weld-penetration monitor
page 135 MFS-29064

GAS VALVES
Dual-flow-rate valve
page 116 MSC-20849

GEARS
Measuring gearbox torque loss
page 102 NPO-15794

GRADIENTS
Computing composition/depth profiles from X-ray diffraction
page 78 LAR-13356

GRAPHITE-EPOXY COMPOSITES
Monitoring prepregs as they cure
page 82 LAR-13335

H

HAMMERS
Electromagnetic hammer for metal-working
page 128 MFS-27096

HEAT EXCHANGERS
Measuring heat-exchanger water leakage
page 103 MSC-20811

HEAT PIPES
High-performance heat pipe with screen mesh
page 101 MSC-20497

Multileg heat-pipe evaporator page 109 MSC-20812
Heat pipe precools and reheats dehumidified air page 111 KSC-11311

HEAT RESISTANT ALLOYS
Low-cobalt powder-metallurgy superalloy page 84 LEW-14113

Forging oxide-dispersion-strengthened superalloys page 135 LEW-14179

HEAT SHIELDING
Wrinkle-free hydroforming of wire mesh page 139 MFS-29111

HERMETIC SEALS
Hermetic edge seals for photovoltaic modules page 138 NPO-16427

HIGHWAYS
Economical video monitoring of traffic page 61 NPO-16473

HOLDERS
Holder for tinning microcircuit leads page 136 MSC-20662

Laser holder aids centering of X-ray head page 104 MFS-29067

HOLOGRAPHY
Finding brazing voids by holography page 127 MSC-20495

HUMAN FACTORS ENGINEERING
Simplified ride-comfort program page 107 LAR-13289

HYDRAULIC DRIVES
Portable hydraulic power pack page 115 KSC-11318

HYDRAULIC EQUIPMENT
Variable-displacement hydraulic drive unit page 121 MSC-20728

HYDROFORMING
Wrinkle-free hydroforming of wire mesh page 139 MFS-29111

HYGROMETERS
Measuring heat-exchanger water leakage page 103 MSC-20811

ICING
Ice detector for aircraft page 100 LAR-13403

IMAGE PROCESSING
Reducing dark currents in charge-coupled devices page 38 NPO-16150

Detector arrays with image-plane processing page 60 LAR-13391

INCONEL (TRADEMARK)
Forging oxide-dispersion-strengthened superalloys page 135 LEW-14179

INDUCTION HEATING
A rapid attachment of strain gages page 98 LAR-13237

Rapid adhesive bonding of composites page 124 LAR-13277

INFRARED IMAGERY
Multispectral infrared images of terrain page 69 NPO-16295

INSTRUMENT FLIGHT RULES
In-flight simulator for IFR training page 56 KSC-11218

INTEGRATED CIRCUITS
Integrated-circuit active digital filter page 62 NPO-16020

Single-event upsets caused by high-energy protons page 68 NPO-16504

INTERMEDIATE FREQUENCY
Intermediate-frequency-to-video-band converter page 64 NPO-16214

ION BEAMS
Improvements in cluster-beam deposition page 137 NPO-16518

ION IMPLANTATION
Reducing dark currents in charge-coupled devices page 38 NPO-16150

JIGS
Jig for removing rivets page 113 MSC-20797

Solar-cell-junction processing system page 125 NPO-16540

JOINTS (JUNCTIONS)
Optimized bolted joint page 103 LAR-13250

Rotary joints with electrical connections page 117 NPO-16250

More leakproof swaged joints in thin-wall tubing page 126 MSC-20882

LASERS
Brewster-plate spoiler for laser spectrometers page 72 NPO-16567

Timed-multiple-laser array page 58 NPO-16433

Laser holder aids centering of X-ray head page 104 MFS-29067

LEAKAGE
Measuring heat-exchanger water leakage page 103 MSC-20811

LEVITATION
Pulsed-corona electrostatic charger page 50 NPO-16523

LOAD TESTS
Optimized bolted joint page 103 LAR-13250

LOADING OPERATIONS
Transfer mechanisms for heavy loads page 108 KSC-11292

LOW GRAVITY MANUFACTURING
Low-gravity alloy studies on aircraft page 80 MFS-25967

LUBRICATION
Lubricating holes for corroded nuts and bolts page 123 MFS-28086

MACHINING
Detection of machining chips by pressure-reversal page 114 MFS-29076

Rotating drive for electrical-arc machining page 120 MFS-19946

MANUAL CONTROL
Survey of hand controllers for teleoperation page 121 NPO-16610

MATERIALS HANDLING
Transfer mechanisms for heavy loads page 108 KSC-11292

MECHANICAL MEASUREMENT
Clip-on extensometer page 96 MSC-20710

METAL OXIDE SEMICONDUCTORS
Submicron silicon MOSFET page 40 NPO-16601

Reducing sodium contamination in MOS devices page 86 MFS-28034

METAL PARTICLES
Detection of machining chips by pressure-reversal page 114 MFS-29076

METAL WORKING
Electromagnetic hammer for metal-working page 128 MFS-27096

MICROELECTRONICS
Holder for tinning microcircuit leads page 136 MSC-20662

MICROSTRIP TRANSMISSION LINES
Buried-dielectric-microstrip network page 42 LAR-13285

MICROWAVE ANTENNAS
Microwave antenna with reduced noise leakage page 48 NPO-15785

MICROWAVE EMISSION
Microwave power from natural emitters page 77 NPO-16581

MICROWAVE SENSORS
Microwave sensor measures turbo pump speed page 67 MFS-28083

MINING
A manifold coal-slurry haulage system page 110 NPO-16471

MOLECULAR BEAMS
Improvements in cluster-beam deposition page 137 NPO-16518

MONITORS
Television monitoring system for welding page 138 MFS-29104

MOUNTING
A rapid attachment of strain gages page 98 LAR-13237

NICKEL HYDROGEN BATTERIES
Advanced IPV nickel/hydrogen cell page 54 LEW-13969

NOISE (SOUND)
Simplified ride-comfort program page 107 LAR-13289

NONDESTRUCTIVE TESTS
Detecting cavitation pitting without disassembly page 98 MFS-19902

Finding brazing voids by holography page 127 MSC-20495

NUMERICAL ANALYSIS
Derivatives of the arithmetic-geometric mean page 140 MFS-26018

NUTS (FASTENERS)
Internally wrenching nut page 93 MFS-29068

Lubricating holes for corroded nuts and bolts page 123 MFS-28086

OPACITY
"Curtainless" Window page 119 MSC-18417

OPEN CIRCUIT VOLTAGE
Improved high/low junction silicon solar cell page 34 LEW-13618

OPTICAL DATA PROCESSING
Detector arrays with image-plane processing page 60 LAR-13391

OPTICAL EQUIPMENT
Easily accessible camera mount page 99 KSC-11316

ORIFICE FLOW
Precise conductance valve insert page 97 LAR-13340

OSCILLATION DAMPERS
Oscillation damper with spring assist page 116 NPO-16223

OSCILLOSCOPES
Hardware/software expansion of display terminal and CPU page 85 LAR-13350

PHOTOVOLTAIC CELLS
Hermetic edge seals for photovoltaic modules page 138 NPO-16427

PIPELINING (COMPUTERS)
Integrated-circuit active digital filter page 62 NPO-16020

PIPES (TUBES)
More leakproof swaged joints in thin-wall tubing page 126 MSC-20882

PITTING
Detecting cavitation pitting without disassembly page 98 MFS-19902

PLASMA GENERATORS
Plasma source for charge control page 68 NPO-16576

POLYIMIDES
Colorless polyimides containing phenoxy-linked diamines page 87 LAR-13353

POLYMERIC FILMS
Colorless polyimides containing phenoxy-linked diamines page 87 LAR-13353

PORTABLE EQUIPMENT
Portable hydraulic power pack page 115 KSC-11318

POROUS MATERIALS
Making high-porosity alloy spheroids page 85 MFS-25997

POWDER METALLURGY
Low-cobalt powder-metallurgy superalloy page 84 LEW-14113

PREPREGS
Monitoring prepreps as they cure page 82 LAR-13335

PRESSURE SENSORS
Pressure-sensitive resistor material page 86 NPO-16567

PRINTED CIRCUITS
Flex circuitry for confined spaces page 52 MSC-20773

PROTONS
Single-event upsets caused by high-energy protons page 68 NPO-16504

PULSE HEATING
Seebeck coefficient measured with differential heat pulses page 70 NPO-16506

PULSED RADIATION
Timed-multiple-laser array page 58 NPO-16433

RADIATION PATTERNS
Calculating directivities of planar-array antenna feeds page 51 NPO-16505

RADIATION SHIELDING
Single-event upsets caused by high-energy protons page 68 NPO-16504

RADIOMETERS
Microwave power from natural emitters page 77 NPO-16581

RAIL TRANSPORTATION
Emergency brake for tracked vehicles page 118 MSC-20513

RANDOM ACCESS MEMORY
Simulating single-event upsets in bipolar RAM's page 67 NPO-16491

REFRACTORY MATERIALS
Attaching metal fasteners to silica tiles page 122 MSC-20537

REMOTE HANDLING
Pressure-sensitive resistor material page 86 NPO-16567

Survey of hand controllers for teleoperation page 121 NPO-16610

REMOTE MANIPULATOR SYSTEM
Digital controller for remote manipulator page 114 NPO-16470

RIDING QUALITY
Simplified ride-comfort program page 107 LAR-13289

RIVETS
Jig for removing rivets page 113 MSC-20797

ROBOTS
Pressure-sensitive resistor material page 86 NPO-16567

ROTORS
Rotary joints with electrical connections page 117 NPO-16250

SECURITY
Secure disposal container for classified papers page 120 NPO-16517

SEEBECK EFFECT
Seebeck coefficient measured with differential heat pulses page 70 NPO-16506

SEMICONDUCTING FILMS
Improvements in cluster-beam deposition page 137 NPO-16518

SEMICONDUCTOR JUNCTIONS
Improved high/low junction silicon solar cell page 34 LEW-13618

Improved solar-cell tunnel junction page 53 NPO-16526

Solar-cell-junction processing system page 125 NPO-16540

SEMICONDUCTORS (MATERIALS)
Seebeck coefficient measured with differential heat pulses page 70 NPO-16506

SEPARATION
Reliable one-shot separation of connectors page 52 MSC-20839

SERVOCONTROL
Variable-displacement hydraulic drive unit page 121 MSC-20728

SETTING
A rapid attachment of strain gages page 98 LAR-13237

SHOCK ABSORBERS
Self-aligning end supports for energy absorber page 94 LAR-13295

SIGNAL TO NOISE RATIOS
Microwave power from natural emitters page 77 NPO-16581

SILICON
Improved solar-cell tunnel junction page 53 NPO-16526

Compact plasma deposition chamber page 123 NPO-16469

SKIN FRICTION
Combined devices for turbulent-drag reduction page 94 LAR-13286

SLURRIES
A manifold coal-slurry haulage system page 110 NPO-16471

SOLAR CELLS
Improved high/low junction silicon solar cell page 34 LEW-13618

Improved solar-cell tunnel junction page 53 NPO-16526

Compact plasma deposition chamber page 123 NPO-16469

Solar-cell-junction processing system page 125 NPO-16540

Hermetic edge seals for photovoltaic modules page 138 NPO-16427

SOLDERING
Holder for tinning microcircuit leads page 136 MSC-20662

SOLIDIFICATION
Low-gravity alloy studies on aircraft page 80 MFS-25967

SOUND TRANSDUCERS
Detecting contaminant particles acoustically page 127 MFS-29078

SPARK MACHINING
Rotating drive for electrical-arc machining page 120 MFS-19946

SPECTROMETERS
Brewster-plate spoiler for laser spectrometers page 72 NPO-16567

SPEED INDICATORS
Microwave sensor measures turbo pump speed page 67 MFS-28083

SPHEROIDS
Making high-porosity alloy spheroids page 85 MFS-25997

STEADY STATE
Graphical method for predicting steady-state temperature page 100 MSC-20835

STOICHIOMETRY
Computing composition/depth profiles from X-ray diffraction page 78 LAR-13356

STORAGE BATTERIES
Advanced IPV nickel/hydrogen cell page 54 LEW-13969

STRAIN GAGES
Clip-on extensometer
page 96 MSC-20710
A rapid attachment of
strain gages
page 98 LAR-13237

SUBSTRATES
Compact plasma
deposition chamber
page 123 NPO-16469

SUITS
Self-contained neutral-
buoyancy suit
page 90 MSC-20424

SUPPORTS
Cradles for support in
transit
page 92 MSC-20725
Easily accessible
camera mount
page 99 KSC-11316
Self-aligning end supports
for energy absorber
page 94 LAR-13295

SWAGING
More leakproof swaged
joints in thin-wall tubing
page 126 MSC-20882

T

TELECOMMUNICATION
Economical video
monitoring of traffic
page 61 NPO-16473

TELEOPERATORS
Survey of hand
controllers for
teleoperation
page 121 NPO-16610

TELESCOPES
Test method for X-ray
telescopes
page 75 MFS-26020

TEMPERATURE
Graphical method for
predicting steady-state
temperature
page 100 MSC-20835

TERRAIN ANALYSIS
Multispectral infrared
images of terrain
page 69 NPO-16295

THERMODYNAMIC PROPERTIES
Thermodynamic
calculators for complex
chemical mixtures
page 79 LEW-14166

THERMOELECTRIC GENERATORS
Brush-type connectors
for thermoelectric
elements
page 44 NPO-16545

THERMOELECTRICITY
Seebeck coefficient
measured with
differential heat pulses
page 70 NPO-16506

TILES
Attaching metal
fasteners to silica tiles
page 122 MSC-20537

TOOLS
Electromagnetic hammer
for metalworking
page 128 MFS-27096
Jig for removing rivets
page 113 MSC-20797
Holder for tinning
microcircuit leads
page 136 MSC-20662

TORQUE METERS
Measuring gearbox
torque loss
page 102 NPO-15794

TRAFFIC
Economical video
monitoring of traffic
page 61 NPO-16473

TRAINING SIMULATORS
In-flight simulator for
IFR training
page 56 KSC-11218

TRANSISTORS
Submicron silicon
MOSFET
page 40 NPO-16601

Simulating single-event
upsets in bipolar RAM's
page 67 NPO-16491

Reducing sodium
contamination in MOS
devices
page 86 MFS-28034

TRANSMISSIONS (MACHINE ELEMENTS)
Measuring gearbox
torque loss
page 102 NPO-15794

TRANSPARENT MATERIALS
Colorless polyimides
containing phenoxy-
linked diamines
page 87 LAR-13353

TRANSPORT PROPERTIES
Thermodynamic
calculators for complex
chemical mixtures
page 79 LEW-14166

TRANSPORTATION
Cradles for support in
transit
page 92 MSC-20725

TURBINE PUMPS
Microwave sensor
measures turbo pump
speed
page 67 MFS-28083

TURBOMACHINERY
Detecting cavitation
pitting without
disassembly
page 98 MFS-19902
Detecting contaminant
particles acoustically
page 127 MFS-29078

UNLOADING
Transfer mechanisms for
heavy loads
page 108 KSC-11292

V

VACUUM GAGES
Pseudolog digital-to-
analog converter
page 65 LEW-14219

VALVES
Dual-flow-rate valve
page 116 MSC-20849
Precise conductance
valve insert
page 97 LAR-13340

VIBRATION ISOLATORS
Oscillation damper with
spring assist
page 116 NPO-16223

VIBRATION PERCEPTION
Simplified ride-comfort
program
page 107 LAR-13289

VIDEO COMMUNICATION
Intermediate-frequency-
to-video-band converter
page 64 NPO-16214

W

WAVEGUIDES
Buried-dielectric-
microstrip network
page 42 LAR-13285

WEIGHTLESSNESS
Self-contained neutral-
buoyancy suit
page 90 MSC-20424

WELDING
Acoustic-emission weld-
penetration monitor
page 135 MFS-29064
Television monitoring
system for welding
page 138 MFS-29104

WINDOWS (APERTURES)
"Curtainless" Window
page 119 MSC-18417

WIRE CLOTH
High-performance heat
pipe with screen mesh
page 101 MSC-20497
Wrinkle-free
hydroforming of wire
mesh
page 139 MFS-29111

X

X-RAY DIFFRACTION
Computing
composition/depth
profiles from X-ray
diffraction
page 78 LAR-13356

X-RAY INSPECTION
Laser holder aids
centering of X-ray head
page 104 MFS-29067

X-RAY TELESCOPES
Test method for X-ray
telescopes
page 75 MFS-26020

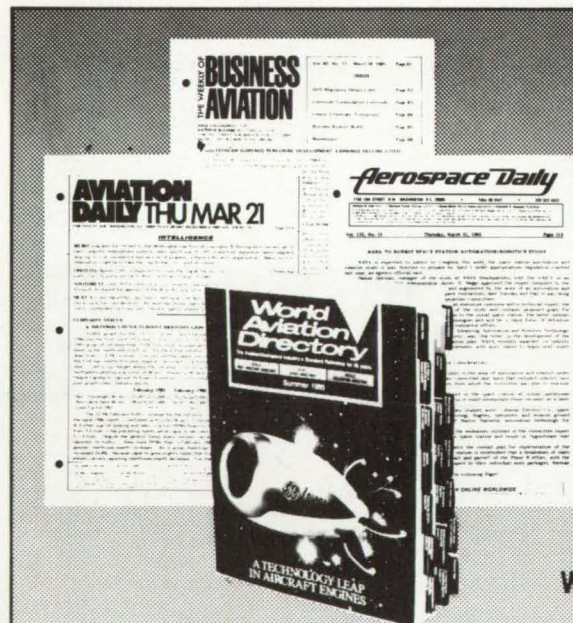

Are You a Subscriber?

The most relied-upon
"intelligence/communications"
network serving the
aviation/aerospace industry
worldwide.

Write on company letterhead or call for FREE trial subscriptions:

- 3 weeks of Aerospace Daily*
- 3 weeks of Aviation Daily
- 4 weeks of Business Aviation
- 30 day inspection of World Aviation Directory

*Aerospace Daily is now on-line as part of a comprehensive network of electronic databases called **Aerospace Online**. Call 202-822-4691 for a one month test at only a nominal cost.

Murdoch Magazines • 1156 15th St., NW • Washington, DC 20005 • 202-822-4600

DISCOVER

DISCOVER an advanced research and development group made up of some of the nation's leading technologists...

DISCOVER a group that is backed by the resources of twenty leading American corporations, committed to maintaining U.S. superiority in microelectronic and computer science technology...

DISCOVER that group in an environment designed specifically to encourage, recognize and reward individual creativity in the development of fundamental technologies that go significantly beyond the current "state of the art"...

DISCOVER new capabilities as part of that group...

MICROELECTRONICS AND COMPUTER TECHNOLOGY CORPORATION (MCC) is located in Austin, Texas and has selected staffing needs in the following areas:

- Expert and Knowledge Based Systems
- Advanced Database Technology
- Human Interface
- Parallel Processing Architectures
- VLSI/CAD
- Packaging and Interconnect Technology
- Software Technology

Challenging opportunities exist for technical management, senior researchers and professionals with strong

academic backgrounds (Ph.D. and Masters or equivalent) and a demonstrated record of performance involving advanced research and development in at least one of the above areas.

We offer a compensation and relocation plan as unique and appealing as our career opportunities.

If you have the necessary qualifications and would like to be a part of this exciting new venture, you should send your resume for consideration as a member of the MCC Research Team to: Vice President, Human Resources, MCC, Echelon I, 9430 Research Blvd., Austin, Texas 78759. We are an equal opportunity employer.

The MCC logo consists of the letters "MCC" in a bold, sans-serif font, enclosed within a white rectangular border. The logo is positioned centrally in the upper half of the advertisement.The MCC logo is displayed on a white, ribbon-like banner that is part of a large, stylized graphic element. This graphic element is a thick, yellowish-gold ribbon that loops and curves across the lower half of the page, creating a sense of movement and depth. The ribbon's surface has a slight gradient and shadow, giving it a three-dimensional appearance. The "MCC" text is printed in a bold, sans-serif font on the white banner.

A sound cleaning investment.

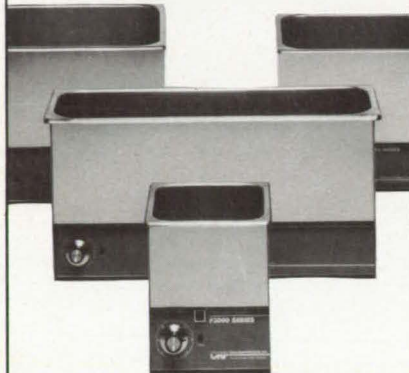

When it comes to ultrasonic cleaners, more and more industries are making the sound decision...new F3000 series Ultrasonic Cleaners from Clean Room Products.

F3000 cleaners are available in nine sizes, covering a range of capacities from 1/2 to 7 1/2 gallons. Innovative circuit design offers the most efficient cleaning available, while protecting sensitive parts from damage. Automatic self-tuning compensates for changes in liquid level, temperature, and parts loading. And plug-in circuit modules mean easy maintenance. In addition, CRP chemists have compounded five new solutions to meet every ultrasonic cleaning requirement.

For over 20 years, CRP has specialized in providing complete clean room environments, equipment, and supplies. Our six divisions are professionally managed and staffed to serve your every clean room need.

To find out more about F3000 series Ultrasonic Cleaners or other clean room products and services, write or call today.

CRP

Clean Room Products, Inc.

Productivity Through
Engineered Environments

56 Penataquit Avenue
Bay Shore, NY 11706
516-968-8282

Letters

The "Letters" column is designed to encourage a wide exchange of ideas among NASA Tech Briefs readers. To contribute a request for information or to respond to such a request, use the feedback cards in this issue, or write or call: Manager/Technology Transfer Division, P.O. Box 8757, Baltimore/Washington International Airport, MD 21240; (301) 859-5300. While we can print only a small number of letters, we will endeavor to select those that are of varied and wide interest.

GETTING SPECIFIC

The computer maintenance technology program has been in existence here at TSTI for only one year. We have received a few of the Tech Briefs today, and after reading them plan to integrate them into our program as soon as possible. They are well written.

We are training people to component-level in computer and peripheral repair. Your tech briefs are well ahead of any textbooks available and allow us to train people closer to state of the art.

Robert J.K. Larsen
Instructor/Resource Officer
Texas State Technical Institute
Waco, TX

I have long been interested in solar power and, through the information you provided, I have built a solar power system at home. This project led me to the design of an automatic tracking system for plate collectors, which has been operative for three years and is working fine.

Glenn E. Eiden
Sr. Laboratory Technician
Magnavox Electronic Co.
Fort Wayne, IN

We have investigated means of reducing aerodynamic drag on tractor-trailer trucking operations. This was started by an article in NASA Tech Briefs on modifying a tractor-trailer configuration. Your article was based on theory and was not practical for our purposes, i.e., no provision for bumpers or window wipers on tractors. However, we did modify our truck fleet to improve fuel efficiency.

Henry Dankenbring
Mechanical Engineer
Pepperidge Farm, Incorporated
Norwalk, CT

Our lab supports research and development of propellants and components for ICBMs. In that role, new test and measurement techniques are being developed. One of the articles stimulated our interest in using ultrasonics as an epoxy cure monitoring method. The success has led to many other uses. Reading your briefs is like brainstorming with experts in every discipline—a great help.

James R. Dyal
Process Engineer
Aerojet Propulsion Co.
Sacramento, CA

The Summer 1985 issue has two very useful articles on arc lamps. I was reading about commercial assemblies, but now plan to build my own from your diagrams! This will save me a good deal of money.

John Hoebing
Physicist
Spectradyne
Chicago, IL

Having a wind charger system and battery bank requiring distilled water, I have scaled down a solar distiller shown in your pages to produce a system to meet my needs. Prior to building the small version, I was constantly buying bottled water. Many of your flat plate collector ideas have been put aside for later experimentation.

Brad Evans
Senior Industrial Engineer
Fairchild Aviation
San Antonio, TX

A tech report originally published in German was translated and made public by NASA's TU program. It is of utmost practical importance to what I am doing at present. The paper is on debinderizing reactions in ceramics at various temperatures. It helped us to understand the organic reactions with ceramics better, to set up firing schedules more scientifically, and to save substantially on fuel. I personally applaud NASA's TU endeavors in such instances of technology transfer and utilization.

Sanjoy K. Das
Ceramic Engineer
R & W Products, Inc.
Auburn, CA

I will use Tech Briefs to help me find new materials (ex: thermal setting plastics, graphite composite plastic compounds, etc.) to make new and better braces for orthopedics and sports industries. I'm also interested in cryo-technology as related to the medical industry—specifically physical therapy management of sports injuries.

Thomas E. Detty
Director of R & D
Pro Orthopedic Devices, Inc.
Tucson, AZ

NASA Tech Briefs has brought my company into contact with federal research labs, thus helping dissemination of technology a small company cannot afford.

Peter H. Karatassos, Ph.D.
Optimum Technologies, Inc.
Big Flats, NY

QUID PRO QUO

The advertisement (NTB, Fall '85, p.167) showing the American businessman shooting himself in the foot with a smile (not a grimace) is indicative of American business acumen. Your "briefs" appeal greatly to the entrepreneur. Is there any organization that takes these inventions to product utilization?

Orlando Holway IV
Marketing Manager
Omnimedical
Antioch, IL

We are a fairly new company, organized to commercialize existing and emerging technology by developing new products which can be used by industry, government, academia and the public in general. We are using back issues of Tech Briefs and will use Tech Briefs to identify those developments which can be integrated into our data base for evaluation and application to our commercial ventures.

J.R. Maxfield
Chairman of the Board
Corp. for Commercial Space
Industries
Houston, TX

Many times I wonder if other manufacturers are developing and selling equipment based on NASA research. For example, the acoustic flame efficiency meter might already be nearly available, and I would not have to go through further experiment and prototype. Could you flag such a situation in "Briefs"?

D. Hammerton
Principal Engineer
Polaroid Corp.
Norwood, MA

Many of the inventions reported in NASA Tech Briefs are patented or are under consideration for a patent at the time they are published. The current patent status is described at the end of the article; otherwise, there is no statement about patents. If you want to know more about the patent program or are interested in licensing a particular invention, contact the Patent Counsel at the NASA Field Center that sponsored the research (see page 21). Be sure to refer to the NASA reference number at the end of the Tech Brief.

In addition to inventions described in NASA Tech Briefs, "NASA Patent Abstract Bibliography" (PAB), containing abstracts of all NASA inventions, can be purchased from National Technical Information Service, 5285 Port Royal Road, Springfield, VA 22161. The PAB is updated semiannually.

AS YOU LIKE IT

Found article on Ames very interesting, since it is just down the street from our company. Would appreciate article about SARFAT program—this is among my latest interests.

Dr. M. Mladejovsky
Manager, CAD
Performance Semiconductor
Sunnyvale, CA

Could Tech Briefs dedicate some space to the topic: "What NASA Would Like to Do But Isn't Doing"?

Benjamin J. Harris
Senior Engineer
Martin Marietta
Denver, CO

It would be most helpful to include a dozen or so reviews of GAS can experiments and related instrumentation, and compare hardware and software for bio, pharmaceutical and silicon processing with other new tech brief offerings. This would be most productive in getting more users on shuttle flights quickly with good results.

David Hessler
Engineer
Burroughs
Paoli, PA

We read with interest all your articles on hydrogen storage and handling. I would like to see articles on small business/NASA working together.

Gregory J. Egan
Marketing Manager
Hydrogen Consultants
Denver, CO

Editorial Note: NASA Tech Briefs' editors welcome your comments and suggestions regarding our feature articles. We will endeavor to address your interests as we expand the editorial focus of the magazine, but first we need to know what your interests are. Please send your comments and suggestions directly to the Editor, NASA Tech Briefs, 41 East 42nd St., Suite 921, New York, NY 10017.

Advertiser's Index

A-E Systems Management, Inc. (RAC 327*) 6	Laser Precision Corporation (RAC 302) 59
Allied Bendix Aerospace (RAC 421) 53	Martin Marietta Cov. II-1
Alslys, Inc. (RAC 341) 41	MCC (RAC 304) 145
A.O. Smith Data Systems, Inc. (RAC 426) 11	McDonnell Douglas Corp. (RAC 372) Cov.IV
Astro-Med, Inc. (RAC 424) 43	McDonnell Douglas Corp. (RAC 373) 106-107
Boeing Electronics Company (RAC 414) 39	Metal Bellows Corp. (RAC 412) 95
Brimrose Corporation of America (RAC 415) 77	Motorola Inc., Government Electronics Group (RAC 375) 23
Clean Room Products (RAC 321) 146	Nanmac Corporation (RAC 405) 79
Datatape (RAC 340) 141	National Instruments (RAC 348) 47
Fairchild Control Systems Co. (RAC 357) 33	Pacific Scientific (RAC 301) 29
Fiberite (RAC 307) 88-89	Philips Test & Measurement (RAC 344) 36-37
Greene, Tweed & Co. (RAC 328) 139	Pioneer Electric & Research Corp. (RAC 305,377) 79
Grumman Data Systems (RAC 363) 18-19	Post Offers 91
Harris Aerospace (RAC 410) 12-13	Power Technology Inc. (RAC 320) 30
Honeywell Inc. Space and Strategic Avionics Division (RAC 364) 150, Cov.III	Pressure Systems, Incorporated (RAC 378) 83
IBM Federal Systems Division (RAC 365) 4-5	Schott Glass Technologies Inc. (RAC 383) 81
IBM Information Systems (RAC 390) 16-17	Shearson Lehman Bros. Inc. (RAC 384) 76
IFR Inc. (RAC 317) 71	Sony Industries Electro Optics Division (RAC 425) 49
IMSL (RAC 300) 46	Systems Designers Software Inc. (RAC 303) 69
Inland Motor (RAC 423) 35	Systonetics (RAC 391) 55
IntraAction Corp. (RAC 428) 73	Tex Tech Industries Inc. (RAC 392) 84
ITT Electro-Optical Products Div. (RAC 403) 68	3M Federal Systems (RAC 422) 7
Iwatsu Instruments Inc. (RAC 429) 45	Union Carbide Corp. (RAC 407) 24-25
KeveX X-Ray Tube Division (RAC 430) 147	Verdix Corporation (RAC 398) 31
Kodak's Government Systems Div. (RAC 339) 27	Vitro Corporation (RAC 394) 2
Laser Precision Corporation (RAC 427) 78	World Aviation Directory 144

*RAC stands for Reader Action Card. For further information on these advertisers, please circle the RAC number on the Reader Action Card elsewhere in this issue. This index has been compiled as a service to our readers and advertisers. Every precaution is taken to ensure its accuracy, but the publisher assumes no liability for errors or omissions.

NEW PORTABLE X-RAY SOURCES

We've finally eliminated the cumbersome high voltage cable! By combining an X-ray tube, high-voltage generator, and control electronics in one five-pound compact unit we have opened the door to new X-ray applications. This small, rugged X-ray source can be easily moved and mounted to point in any direction. Just connect it to a 12 volt battery. Field service is a snap. Replacing the source takes only minutes and eliminates costly troubleshooting. Available *only* from KeveX. 30, 50 and 70 kV versions. Your new products are limited by your imagination. Call or write:



KeveX X-Ray Tube Division
Box 66860
Scotts Valley, CA 95066
(408) 438-5940

ABOUT THE NASA TECHNOLOGY UTILIZATION PROGRAM

Thumb Index



NASA TU Services



New Product Ideas



Electronic Components and Circuits



Electronic Systems



Physical Sciences



Materials



Life Sciences



Mechanics



Machinery



Fabrication Technology



Mathematics and Information Sciences



Subject Index

This document was prepared under the sponsorship of the National Aeronautics and Space Administration. NASA Tech Briefs is published quarterly and is free to engineers in U.S. industry and to other domestic technology transfer agents. It is both a current-awareness medium and a problem-solving tool. Potential products... industrial processes... basic and applied research... shop and lab techniques... computer software... new sources of technical data... concepts... can be found here. The short section on New Product Ideas highlights a few of the potential new products contained in this issue. The remainder of the volume is organized by technical category to help you quickly review new developments in your areas of interest. Finally, a subject index makes each issue a convenient reference file.

Further information on innovations—Although some new technology announcements are complete in themselves, most are backed up by Technical Support Packages (TSP's). TSP's are available without charge and may be ordered by simply completing a TSP Request Card, found at the back of this volume. Further information on some innovations is available for a nominal fee from other sources, as indicated. In addition, Technology Utilization Officers at NASA Field Centers will often be able to lend necessary guidance and assistance.

Patent Licenses—Patents have been issued to NASA on some of the inventions described, and patent applications have been submitted on others. Each announcement indicates patent status and availability of patent licenses if applicable.

Other Technology Utilization Services—To assist engineers, industrial researchers, business executives, Government officials, and other potential users in applying space technology to their problems, NASA sponsors Industrial Applications Centers. Their services are described on pages 20-22. In addition, an extensive library of computer programs is available through COSMIC, the Technology Utilization Program's outlet for NASA-developed software.

Applications Program—NASA conducts applications engineering projects to help solve public-sector problems in such areas as safety, health, transportation, and environmental protection. Two applications teams, staffed by professionals from a variety of disciplines, assist in this effort by working with Federal agencies and health organizations to identify critical problems amenable to solution by the application of existing NASA technology.

Reader Feedback—We hope you find the information in *NASA Tech Briefs* useful. A reader-feedback card has been included because we want your comments and suggestions on how we can further help you apply NASA innovations and technology to your needs. Please use it; or if you need more space, write to the Manager, Technology Transfer Division, P.O. Box 8757, Baltimore/Washington International Airport, Maryland 21240.

Advertising Reader Service—Reader Action Card (RAC): For further information on the advertisers, please circle the RAC number on the separate Reader Action Card in this issue.

Change of Address—If you wish to have *NASA Tech Briefs* forwarded to your new address, use the Subscription Card enclosed at the back of this volume of *NASA Tech Briefs*. Be sure to check the appropriate box indicating change of address, and also fill in your identification number (T number) in the space indicated. You may also call the Manager, Technology Utilization Office, at (301) 859-5300, ext. 242 or 243.

This document was prepared under the sponsorship of the National Aeronautics and Space Administration. Neither Associated Business Publications, Inc., nor anyone acting on behalf of Associated Business Publications, Inc., nor the United States Government nor any person acting on behalf of the United States Government assumes any liability resulting from the use of the information contained in this document, or warrants that such use will be free from privately owned rights. The U. S. Government does not endorse any commercial product, process, or activity identified in this publication.

Mission **A**ccomplished



“Moving with air, everywhere” would be a fitting slogan for Hovair Systems, Inc. of Ventura, California. Its air film flotation systems provide practically frictionless, omnidirectional lift and transport for all manner of heavy and unwieldy loads. From moving prefabricated home modules between factory assembly stations to rearranging audience seating configurations in television studios and stadiums, Hovair’s air film systems facilitate a variety of processes, ranging from manufacturing to entertainment.

Hovair’s systems are an outgrowth of a technology originally developed by General Motors during the mid-1960s. Under contract to NASA’s Marshall Space Flight Center, General Motors adapted its previously invented air flotation device for a new, large-scale application—moving the components of the gargantuan Saturn V rocket during construction and assembly.

Following the success of this first large-scale application, a group of General Motors engineers who had developed the air bearing technology obtained a license for it, and formed a company to refine and market air bearing systems to private industry. A diverse line of air film transporters, turntables and air cushions for frictionless movement of moderate to heavy loads was introduced in the late 1960s.

The basic building block of the air bearing system is a standard transporter unit. It incorporates air bearings into a steel frame, combining a mount-

NASA Tech Briefs, January/February 1986

ing and positioning surface for the air bearings with a payload platform and a container for associated pneumatic components. The size of the transporter varies according to its application, and the number, size and configuration of the air bearings are also established in proportion to the application. Fundamentally, however, the system’s elements are the same in every application.

The air film load transporter utilizes compressed air from a pre-existing factory supply, making individual hose connections for each transporter unit unnecessary. As air pressure is introduced to the system, the bearings inflate and expand in much the same manner as traditional rigid air cylinders. However, as air pressure increases, it reaches a value at which the compliant diaphragm is fully extended and the total upward lift balances the downward force of the applied load.

At this point, a separation occurs between the operating surface of the transporter and the lower surface of the compliant air bearings, generating an air escape path and creating a dynamic lubricating system. The resultant thin cushion of air eliminates frictional contact, and allows movement of the lifted load at a one-to-one thousand force/weight ratio.

Hovair currently manufactures 100 standard air film systems, in addition to customized designs, such as one supplied to Hughes for simulating the unfolding of satellite solar arrays in a frictionless environment. In this par-

Through the technology transfer process, many of the systems, methods and products pioneered by NASA are re-applied in the private sector, obviating duplicate research and making a broad range of new products and services available to the public.

ticular application, the bearings lift a load weighing only 60 pounds, but for Allis-Chalmers, Hovair supplied a system for lifting and transporting 60-ton tractors along the production line. The addition of accessory elements for powered movement, automatic control and guidance further extend the range of Hovair’s custom and standard systems alike.

Air film movement systems continue to gain acceptance across a broad spectrum of industry, and are particularly popular in heavy equipment manufacturing. This can be attributed to the advantages over traditional transport which air film systems offer. Applicable in a variety of sizes and configurations, they are highly adaptable to designer requirements. Further, they require little if any foundation work and can be moved in the event of relocation or reconfiguration. Finally, they’re energy efficient and low cost, both initially and over time, which makes them especially appealing to those who want to float a load without having to float a loan. □

Although widely applied in other industries, air film systems remain active in their original large-scale application. Above, air film transporters position 180-ton segments of space shuttle solid rocket boosters for test firing in Utah. Below, a crane lowers a transporter unit containing 12 compliant air bearings into position at the Utah site.



NEYWELL AEROSPACE AND DEFENSE

HONEYWELL

WELL AEROSPACE AND DEFENSE

HONEYW

LL AEROSPACE AND DEFENSE

AEROSPACE AND DEFENSE

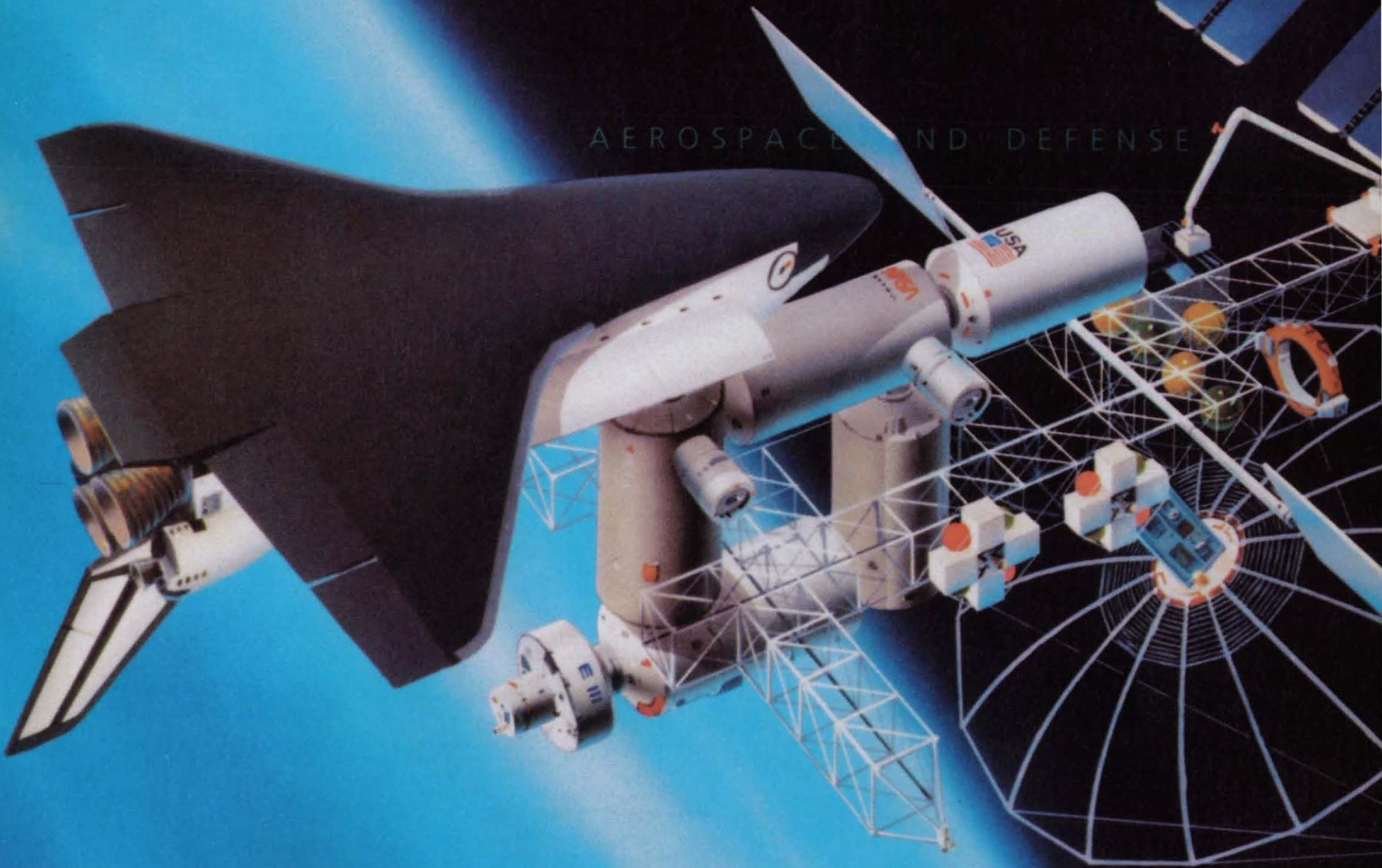

CE AND D

E AND

E A

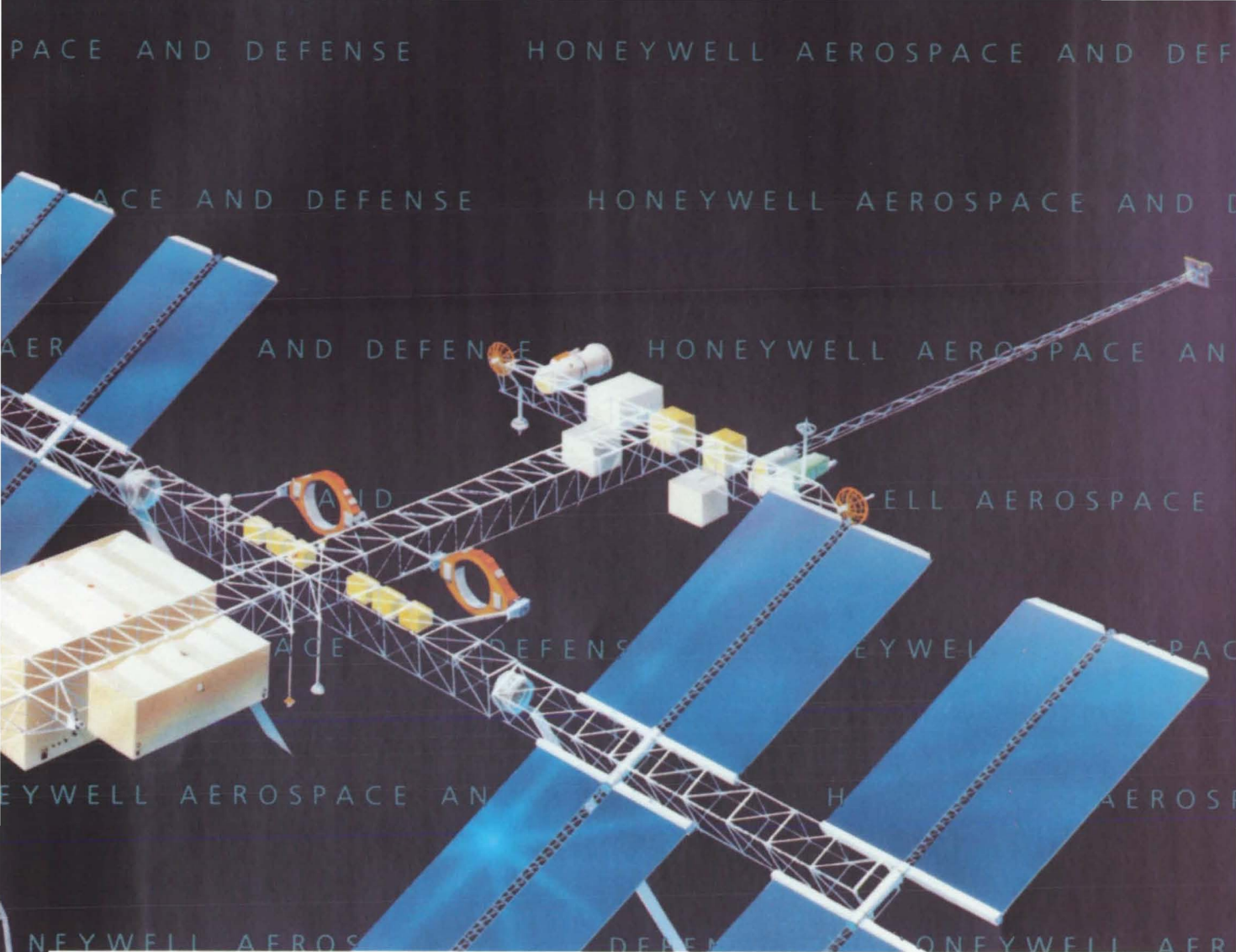

Zero defects at zero gravity.

When you're working on America's first space station, the requirement is zero defects at zero gravity.

Which is why NASA depends on Honeywell Reliability to make advanced space concepts a reality.

Honeywell has played a major role in every one of NASA's manned space missions, from the X15 through Gemini and Apollo, to SkyLab and the Space Shuttle. And now we're working with other leaders in the aerospace industry to engineer critical control systems for life support, power distribution as well as guidance and navigation for NASA's first space station, scheduled for deployment in the mid-1990s.

Honeywell combines advanced technology with reliable performance to ensure America's space program will succeed well into the 21st century—and beyond.

Honeywell Reliability

Together, we can find the answers.

Honeywell

Circle Reader Action No. 364

©1986 Honeywell Inc.

A BUILDING SITE LIKE NO PLACE ON EARTH.

Some structures needed in space are just too big to launch in one piece. Too large and too fragile even to stand alone on Earth, intricate sections can be brought up on successive shuttle flights, plucked from the orbiter by station robot arms, assembled into massive structures by the space station crew, and released to their own orbits. The miracle of microgravity will make light

work of such space construction.

One example is the 20-meter diameter Large Deployable Reflector infrared telescope NASA is planning for the mid-1990s. Consisting of some 100 pieces—large mirrors and supporting structures—when assembled and deployed, the device will permit a variety of deep space investigations.

Without the manned space

station, structures of this size would not be possible.

We think that's a very good reason to build a building site like no place on Earth.

With Eastman Kodak and NASA, McDonnell Douglas is planning the precision techniques needed for construction in space. We are teamed with Honeywell, IBM, Lockheed and RCA for major definition and design work on the station.



MCDONNELL DOUGLAS

© 1985 McDonnell Douglas Corporation

Circle Reader Action No. 372