

Functional Risk Modeling for Lunar Surface Systems

Fraser Thomson^{a*}, Donovan Mathias^b, Susie Go^b, and Hamed Nejad^a

^aEloret Corporation, NASA Ames Research Center, Moffett Field, USA

^bNASA Ames Research Center, Moffett Field, USA

Abstract: We introduce an approach to risk modeling that we call ‘functional modeling’, which we have developed to estimate the capabilities of a lunar base. The functional model tracks the availability of functions provided by systems, in addition to the operational state of those systems’ constituent strings. By tracking functions, we are able to identify cases where identical functions are provided by elements (rovers, habitats, etc.) that are connected together on the lunar surface. We credit functional diversity in those cases, and in doing so compute more realistic estimates of operational mode availabilities.

Keywords: PRA, Functional Modeling, Dynamic PRA, Aerospace.

1. INTRODUCTION

NASA’s Constellation program is designed to return humans to the surface of the moon. Efforts have been underway at NASA centers since 2005 to plan out the details of crewed and un-crewed operations on the lunar surface, and to design surface elements—lunar rovers, habitats, etc.—in support of Constellation program goals. Although Constellation is not currently funded in NASA’s FY2011 budget, efforts continue to bring the program through to the preliminary design review (PDR) phase of analysis and planning, at which point Constellation documents and other products will be archived for posterity.

Our team at NASA Ames has developed reliability models of Constellation lunar surface elements to help designers identify weaknesses in element architectures. We also model the ensemble of elements that operate together during a lunar campaign, with the goal of helping managers and mission planners determine which suite of elements provides the best safety, availability, and capability at the overall campaign level. Lunar campaigns were simulated dynamically at the architecture level using the GoldSim™ Monte Carlo-based risk analysis software.

In this paper, we introduce an approach that we call ‘functional modeling’, which we have developed to estimate the capabilities of a lunar base, the availability of its constituent elements, and the availability of various modes of surface operations to the crew.

2. FUNCTIONAL MODELING OVERVIEW

Any human lunar campaign comprises a set of elements that are delivered to the lunar surface to support crewed surface operations. Figure 1 is an artist’s depiction of some of the habitat, mobility, and construction elements envisioned by the Lunar Surface Systems (LSS) design teams for the Constellation program. Each element delivered to the lunar surface provides a set of functions, such as life support, mobility, etc. These elements are used in various combinations by the astronauts to achieve their mission objectives. In some cases, surface elements may perform unique functions. In other cases, several elements in use together on the lunar surface may provide some redundancy in the functions they provide. For example, a rover and a habitat module that are connected together may each contribute life support functionality. In those cases, elements provide redundancy to each other for those specific functions. When this situation exists, we say that ‘diverse backup’ exists for that particular function or set of functions.

Figure 1: Artist's conception showing a number of surface elements in place on the lunar surface in support of the Constellation program [1]

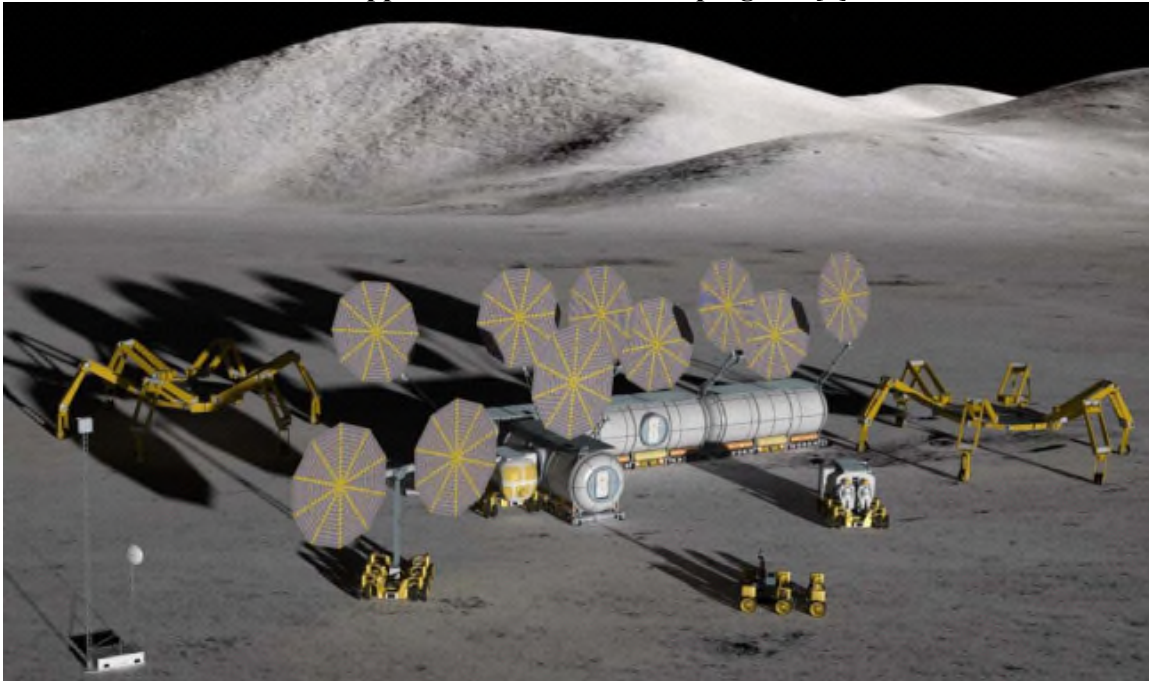

A surface element does not necessarily need to be fully functional in order to be available to accomplish a particular task. As the systems and subsystems of the surface elements fail and are repaired, full element functionality varies, but functional availability may not change at all, depending upon the redundancy (both internal to an element, and due to diverse backup) that exists in the elements and in the way the elements are being used as an ensemble. This fact drove us to develop a model that could track availability at the functional level, as well as at the element level.

The functional modeling approach tracks the functions provided by each surface element at any given time during its stay on the lunar surface, in addition to tracking the state of each element's constituent systems and/or subsystems. As the dynamic simulation proceeds, we track the availability of functions required to meet various operational demands—demands that may be in flux during a lunar surface campaign. By tracking functions, we are able to track the availability of different crewed or un-crewed operational modes, and to perform studies that help managers and mission planners to see the impact of varying the commit criteria for those modes, subject to assumed equipment reliability and repairability levels.

Functional tracking also allows us to credit diverse backup in assessments of campaign-level functionality for crew activities, such as certain roving operations that require several surface elements to be available concurrently. By tracking the availability of diverse backup during different equipment use configurations and activities on the surface, we provide a more realistic picture of the severity, if not survivability, of various failure scenarios. Further, we are able to run sensitivity studies on the level of availability provided by a set of surface elements, under different assumptions of the amount of diverse backup deemed acceptable for a given function (such as life support), or under varying repairability assumptions. We are able to credit partial availability of the various elements, thus obtaining a truer picture of that element's utility to astronaut crews at any point in the campaign.

3. LUNAR SURFACE ELEMENT MODELS

For each surface element in the lunar campaign, we perform a thorough assessment to determine its comprising systems and subsystems. Through detailed discussions with the element design teams, assessment of the system schematics, and careful review of the master equipment lists (MELs), the individual failure rates for major components in each subsystem are assessed and the string structure of the systems/subsystems comprising the element is determined. We use a combination of historical data (from the Space Shuttle and International Space Station), expert opinion, and comparative analogy with the mining and oil/gas industries to estimate component failure rates within each string. Here, a string is defined as a single closed loop in any subsystem design that performs a specific function, and for which any component failure within the string causes the entire string to fail. The failure rate for each redundant string, denoted λ_n , is computed by summing the failure rates of the string's constituent components. We assume that components fail due to random events only, and thus the probability density function of component failures is an exponential distribution.

Figure 2 illustrates this step in the modeling process, using the Environmental Control and Life Support System (ECLSS) of the Pressurized Core Module (PCM) element as an example. The PCM is a pressurized human habitation element proposed by the Constellation LSS architecture team. In the figure, five ECLSS subsystems are identified: fire detection/suppression, air revitalization, water recovery, waste management, and a pressure control subsystem (PCS). The string structure within the subsystems is shown (purple boxes), characterized by mean failure rates λ_n . The specific string structure shown in the figure is for illustrative purposes only, and does not necessarily represent the true ECLSS structure.

Figure 2: A symbolic representation of the subsystem-level models used in the Lunar Surface Systems (LSS) risk analysis. The Environmental Control and Life Support System (ECLSS) is shown in this example.

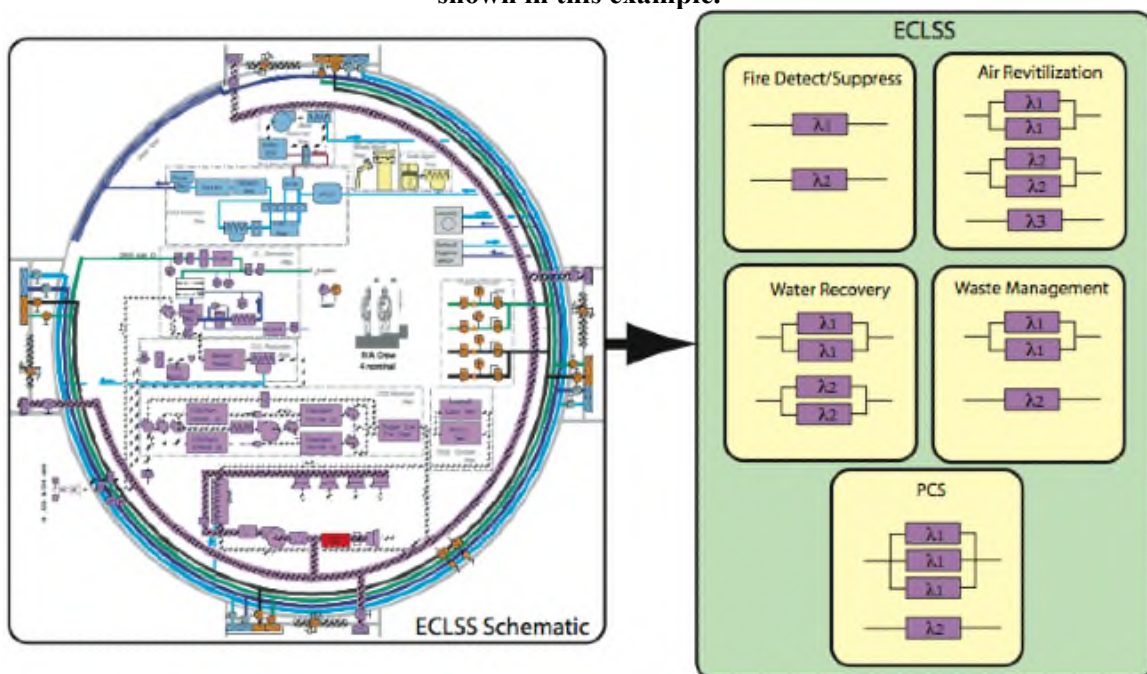

To each subsystem, we map a set of external dependencies, such as power, fuel, life support, etc., that are required for the subsystem to be operational. Systems contained within a surface element work together to provide the functions that the element is designed to deliver, such as mobility, communications, life support, or others. These three basic building blocks---systems/subsystems,

external dependencies, and functions provided---combine to represent an element in the functional model. This is shown symbolically in Figure 3 for the PCM element. Note that the ECLSS system of Figure 2 is represented as one of the five PCM systems in Figure 3.

In our model, an element’s systems act like engines; consuming external dependencies like fuel, and in turn providing functions to the lunar campaign. Multiple subsystems or systems may be required to support a given function. For instance, in the PCM example shown in Figure 3, the ECLSS, Thermal, and Environmental Protection systems together contribute to the function Environmental Protection, which the element provides to the lunar base habitat. Power is required by these three systems as an external dependency. Although mapping of external dependencies and functions to the element is done at the subsystem level in our model, Figure 3 shows this mapping at the system level for clarity.

Figure 3: The Pressurized Core Module (PCM) element model, showing the element proper (blue) with its systems (light green) and subsystems (light yellow), its external dependencies (red), and a generic set of functions that elements may or may not provide (dark yellow). The dependencies and functions provided map according to the black arrows shown (power maps to all systems).

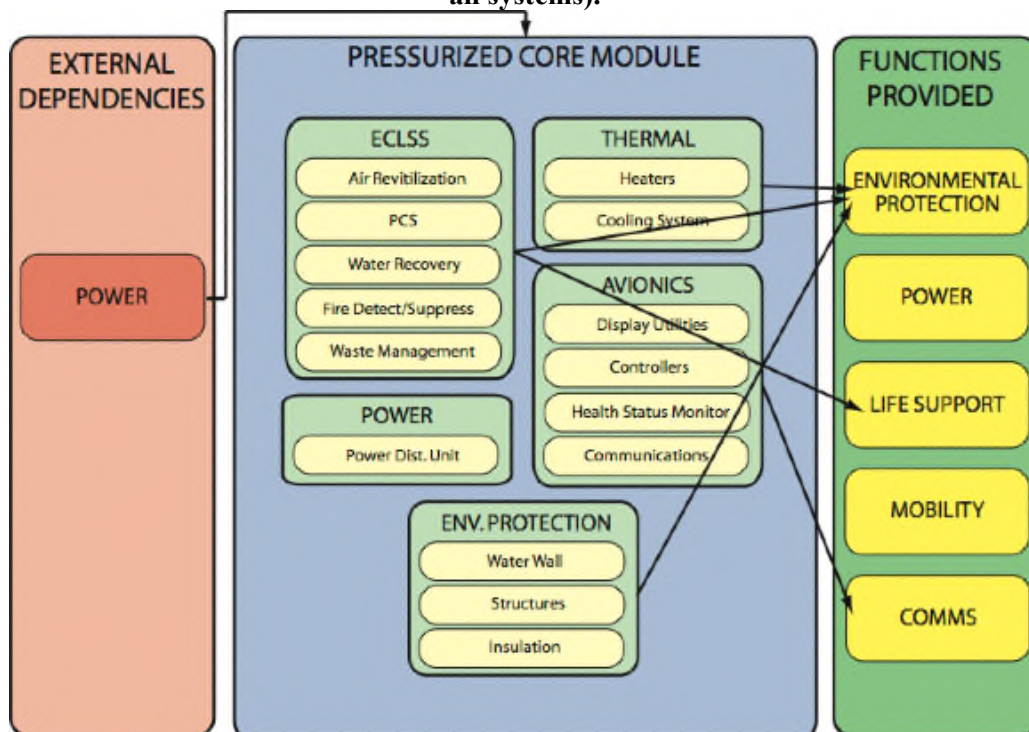

4. LUNAR BASE MODEL AND RESULTS

We use the GoldSim™ Monte Carlo-based risk analysis software to model Constellation lunar surface campaigns. In our model, we implement the symbolic logic of Figure 3 for each surface element populating the lunar base, which may comprise as many as 25 independent elements. Constellation lunar campaign scenarios consist of approximately 37 flights to the moon over a 10- to 12-year period, totalling more than 2000 planned days of human lunar habitation. During the lunar campaign simulation, we toggle elements ‘on’ in the GoldSim™ model according to a cargo manifest that defines the planned element delivery dates and crew arrival/departure dates. We toggle the elements ‘off’ (or to a reduced exposure mode) in the model when the astronaut crew leaves the surface.

As the model runs, the various strings of each element subsystem fail, and are repaired with a probability determined by a general repairability assumption for the lunar campaign. We explicitly track the following metrics.

1. State of Element Repair: At each time step in the Monte Carlo simulation, we record the state of each lunar surface element, creating a record of the systems and subsystems that are operating or failed. This information is used in the functional availability tracking we describe below. As a prerequisite for any rover/sortie activity, we require the participating surface elements to be fully operational (i.e., all strings must be operational) in our model. For power-producing elements, we track the specific power output as a function of time.
2. Outcome of Repair Attempts: We record the total number of successful repairs made to each subsystem during the course of a complete lunar campaign. If a repair attempt fails in our simulation, a second attempt is not made. We assume that a failed repair requires launching a replacement string on a future re-supply flight from earth. As the system design matures and we obtain estimates of the mass contained in each element's subsystem strings, we can use our simulated failed string counts to compute the average failed mass as a function of time—i.e., the total extra mass that must be delivered to the moon to support the upkeep of the lunar base. Since this 'repair mass' will displace other payload mass carried to the lunar surface, it is an important metric to report, potentially helping managers to trade off system reliability requirements with system repairability.
3. Functional Availability: A temporal history of the functional availability of all elements is recorded. With this information, we track the overall availability of different operational modes as a function of mission elapsed time (MET), crediting diverse backup depending on how the surface elements are connected together and used by the crew. By adjusting the commit criteria (i.e., the state of repair/functionality that must exist before initiating a particular activity on the surface) and functionality requirements for different operational modes, we can perform sensitivity studies that help managers and mission planners to see the impact of different operational rules, subject to assumed equipment reliability and repairability levels.

The results of some of our preliminary studies are presented in Figures 4–6. In Figure 4, we show the expected power output (as a function of MET) of the fission surface power system (FSPS), a nuclear reactor that is under study by Constellation mission architects. In the simulation, the reactor is designed to produce 48 kW of power. A portion of the reactor is not serviceable, leading to a steady expected decline in output power over the reactor's life, for the case where the serviceable part of the reactor is always repaired successfully. The figure shows the failure counts instead of a repairability percentage. This is another useful metric, as it may help to set expectations for the level of extravehicular activity (EVA) support required of the astronauts. On average, the serviceable portion of the reactor—comprising its electrical power distribution system—required 32 repair operations during a 4000-day simulation period.

We reduce the number of allowed repairs to investigate the effect that repair limitations (due to limited space for spare parts on cargo landers, limited EVA schedules, etc.) have on the available power. Current design guidelines for the reactor require the output power to exceed 20 kW after about 3000 days of continuous operation. On average, the current model suggests that mission planners allocate resources (time, equipment) to support a minimum of 25 repairs to the reactor in order to meet this performance guideline.

Figure 4: Power output vs. mission elapsed time of the fission surface power system (FSPS), a space-qualified nuclear reactor studied for possible inclusion in the Constellation architecture.

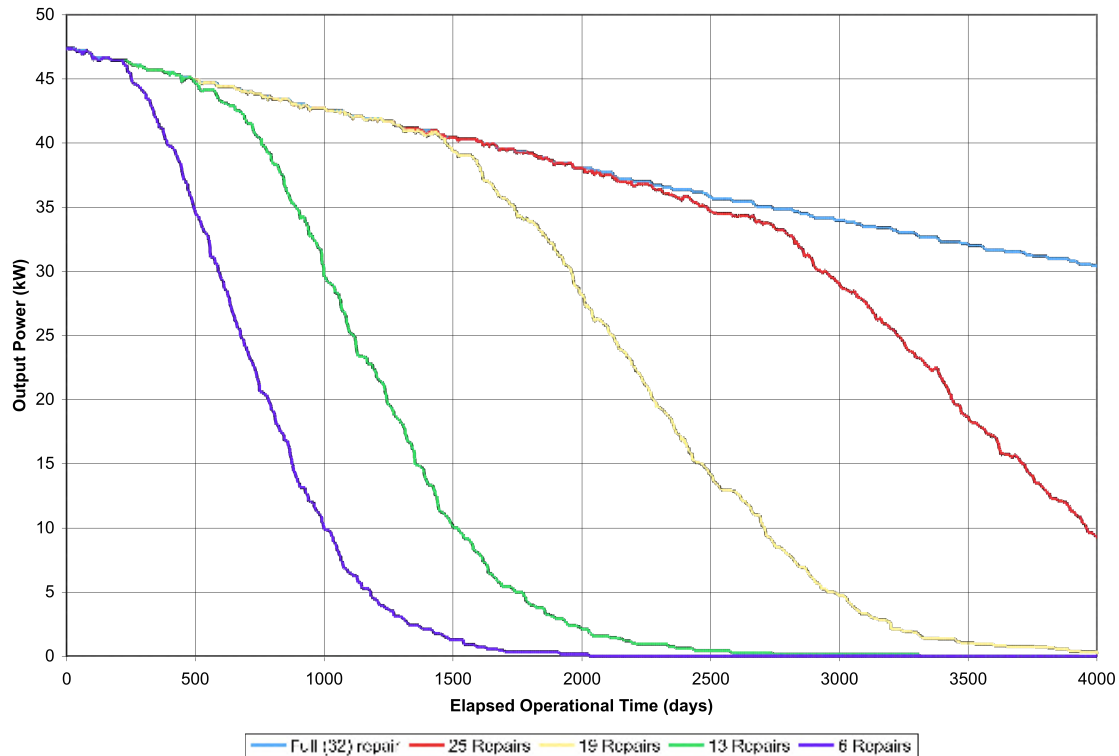

Figure 5 shows the availability of pressurized surface habitation as a function of MET. Individual curves correspond to different levels of reparability, as indicated. The effect of diverse functional backup is included in the figure; in this example, diversity is provided for habitation by three pressurized habitat modules (one of which is the PCM), four rovers (which connect to the PCM and provide redundant ECLSS), three solar power generators, and a nuclear power generator. The delivery of these habitation, roving, and power elements occurs between day 1025 and day 2120 MET in the model, causing an initial increase in the operational availability in the figure. In Figures 5 and 6, gaps in the curves represent periods in the mission plan when crews are not present on the surface.

The power of the functional modeling approach is illustrated in Figure 6. Here, we compare the surface habitation availability computed using our functional model with an availability estimate computed assuming that no diverse backup is available. The two results are presented for the case where 80% of all attempted repairs (to all elements) are successful. Because it accounts for diverse backup, the functional model predicts much greater habitat availability, and thus provides a more realistic assessment of the expected performance of the habitat as an ensemble.

Figure 5: Availability of pressurized surface habitation as a function of equipment repairability. The results reflect the availability of diverse functional backup from lunar excursion rovers (LERs), multiple pressurized modules, and multiple power sources.

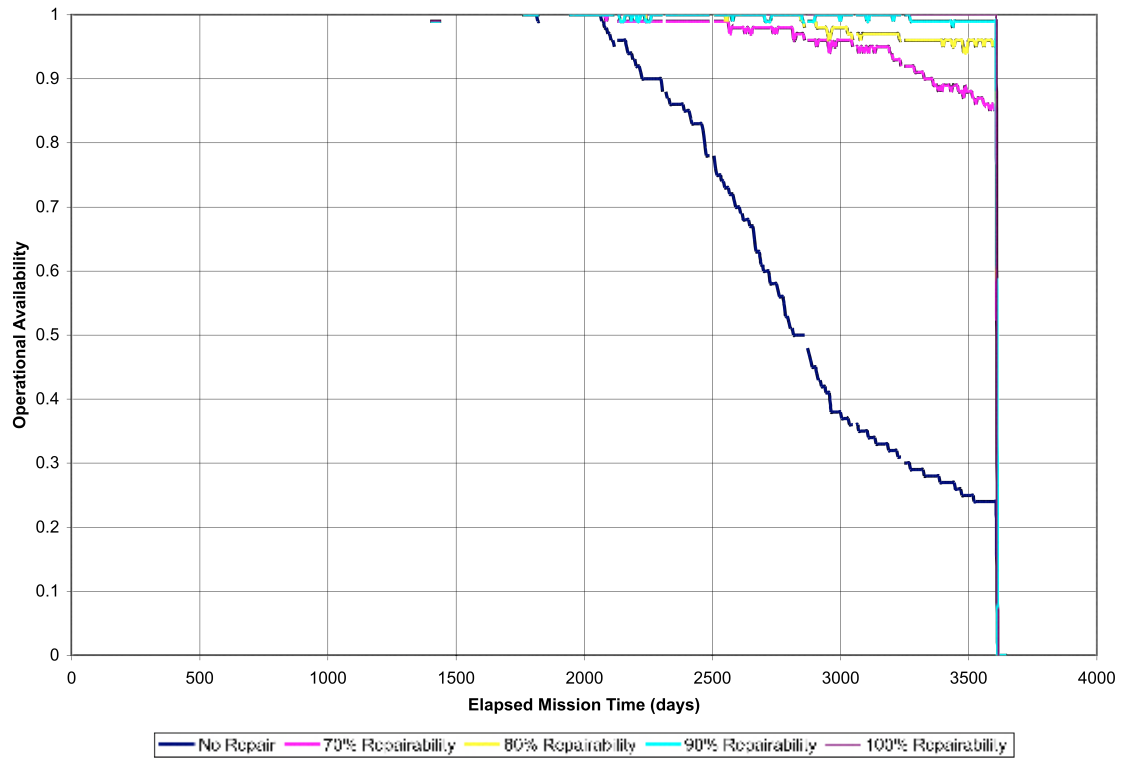
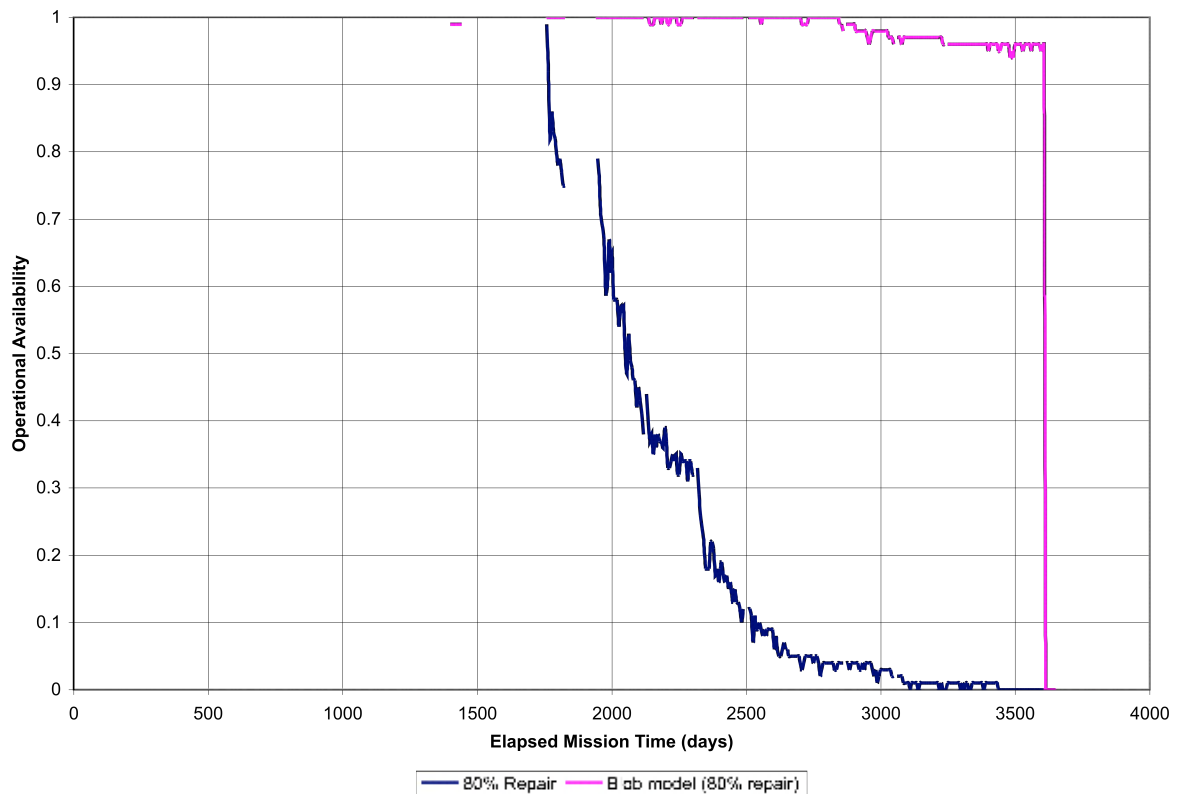

Figure 6: Comparison of the estimated operational availability of a pressurized habitat computed with and without a functional modeling approach. The functional model gives full credit for diverse backup. Both models assume 80% repairability.



5. CONCLUSION

The functional modeling approach yields more realistic estimates of the availability of the various operational modes provided to astronauts by the ensemble of surface elements included in a lunar base architecture. By tracking functional availability the effects of diverse backup, which often exists when two or more independent elements are connected together, is properly accounted for.

References

- [1] <http://luna-ci.com/2009/04/07/lssw-sunflowers-and-the-basic-capabilities-of-nasas-lunar-outpost/>