

# Compact, High Energy 2-micron Coherent Doppler Wind Lidar Development for NASA's Future 3-D Winds Measurement from Space

Upendra N. Singh<sup>1</sup>, Grady Koch<sup>1</sup>, Jirong Yu<sup>1</sup>, Mulugeta Petros<sup>2</sup>, Jeffrey Beyon<sup>1</sup>, Michael J. Kavaya<sup>1</sup>, Bo Trieu<sup>1</sup>, Songsheng Chen<sup>3</sup>, Yingxin Bai<sup>3</sup>, Paul Petzar<sup>4</sup>, Edward A. Modlin<sup>1</sup>, Bruce W. Barnes<sup>1</sup>, and Belay B. Demoz<sup>5</sup>

<sup>1</sup>NASA Langley Research Center, Hampton, VA 23681 USA  
757-864-1570, [Upendra.N.Singh@nasa.gov](mailto:Upendra.N.Singh@nasa.gov)

<sup>2</sup>Science and Technology Corporation, 10 Basil Sawyer Drive, Hampton, VA 23666 USA

<sup>3</sup>SSAI, One Enterprise Parkway, Suite 300, Hampton, VA 23666 USA

<sup>4</sup>National Institute of Aerospace, Hampton, VA 23666 USA

<sup>5</sup>Howard University, Department of Physics and Astronomy, 2355 6<sup>th</sup> Street, Washington, DC 20059, USA

## ABSTRACT

This paper presents an overview of 2-micron laser transmitter development at NASA Langley Research Center for coherent-detection lidar profiling of winds. The novel high-energy, 2-micron, Ho:Tm:LuLiF laser technology developed at NASA Langley was employed to study laser technology currently envisioned by NASA for future global coherent Doppler lidar winds measurement. The 250 mJ, 10 Hz laser was designed as an integral part of a compact lidar transceiver developed for future aircraft flight. Ground-based wind profiles made with this transceiver will be presented. NASA Langley is currently funded to build complete Doppler lidar systems using this transceiver for the DC-8 aircraft in autonomous operation. Recently, LaRC 2-micron coherent Doppler wind lidar system was selected to contribute to the NASA Science Mission Directorate (SMD) Earth Science Division (ESD) hurricane field experiment in 2010 titled Genesis and Rapid Intensification Processes (GRIP). The Doppler lidar system will measure vertical profiles of horizontal vector winds from the DC-8 aircraft using NASA Langley's existing 2-micron, pulsed, coherent detection, Doppler wind lidar system that is ready for DC-8 integration. The measurements will typically extend from the DC-8 to the earth's surface. They will be highly accurate in both wind magnitude and direction. Displays of the data will be provided in real time on the DC-8. The pulsed Doppler wind lidar of NASA Langley Research Center is much more powerful than past Doppler lidars. The operating range, accuracy, range resolution, and time resolution will be unprecedented. We expect the data to play a key role, combined with the other sensors, in improving understanding and predictive algorithms for hurricane strength and track.

## 1. INTRODUCTION

For nearly 30 years, the atmospheric research community has been aware that pulsed laser-based Doppler wind lidars (DWL) promised new insights to the evolution of severe weather such as tropical cyclones, tornadic storms and mesoscale convective complexes. Although there have been a few airborne pulsed DWL field campaigns in this period, advances in the lidar technology and investment in its utility for atmospheric studies is now accelerating, being targeted at not only basic research but also operational meteorology and a future space-based mission. Recent (2008) experiments in the western Pacific involved two airborne pulsed DWL systems in a focused investigation of typhoon genesis and intensification. Results from that effort are now going into the design of an ambitious program of hurricane research using airborne lidars on such platforms as NOAA's P3, NASA's DC8 and Global Hawk and the Navy's P3 and Twin Otter. If all goes as planned, within the next 5 years there will be more than 1000 flight hours of pulsed DWL equipped aircraft collecting data that has the potential to transform the way in which we monitor and predict the lifecycles of severe storms.

NASA Langley Research Center has a long history of developing 2-micron laser transmitter for wind sensing. With support from NASA Laser Risk Reduction Program (LRRP) and Instrument Incubator Program (IIP), NASA Langley Research Center has developed a state-of-the-art compact lidar transceiver for a pulsed coherent Doppler lidar system for wind measurement with an unprecedented laser pulse energy of 250-mJ in a rugged package. This high pulse energy is produced by a Ho:Tm:LuLiF laser with an optical amplifier. While the lidar is meant for use as an airborne instrument, ground-based tests

were carried out to characterize performance of the lidar. Atmospheric measurements will be presented, showing the lidar's capability for wind measurement in the atmospheric boundary layer and free troposphere. Lidar wind measurements are compared to a balloon sonde, showing good agreement between the two sensors.

## 2. TRANSMITTER DESIGN

The design of the lidar, summarized in Table 1 and diagrammed in Figure 1, is similar to that described in a previous publication [1], with the addition of an optical amplifier to boost the energy of a 100-mJ laser oscillator to the 250-mJ level. To summarize the laser architecture, a Ho:Tm:LuLiF rod in a 3-m long cavity provides pulses at a 5 Hz rate. Injection seeding with a beam from a continuous-wave (CW) Ho:Tm:YLF laser creates a single-frequency output spectrum from the pulsed laser. Aside from providing an injection seed source, the CW laser is also used as a local oscillator for the receiver. The amplifier is a rod of Ho:Tm:LuLiF pumped from the side by 792-nm diode laser arrays providing a total pump energy of 7.2 J. After passing through a polarizing beam splitter, the output from the amplifier is directed toward a telescope of 15-cm primary aperture and 20x magnification. With this diameter the beam transmitted to the atmosphere is more than a factor of 10 under the maximum permissible exposure for pulsed lasers, making the output eye safe. A mirror positioned after the telescope deflects the beam vertically toward a beam scanner mounted through the roof of the laboratory. A quarter-wave plate is used before the telescope to create a circular polarization for transmission to the atmosphere. With reflection from aerosols assumed to create backscatter with the opposite sense polarization, the returned light is orthogonally polarized to the outgoing light. The polarizing beam splitter hence reflects the atmospheric return toward the receiver path. Received light is focused into an optical fiber and mixed with the local oscillator for heterodyning on InGaAs photodiodes in a dual-balanced configuration.

Signal processing begins with digitization of the heterodyne signal at 500 Ms/s and 8-bit resolution. Digital signal processing chips parse the heterodyne signal into range bins, perform a Fourier transform on each bin, average across multiple pulses, and find the peak of the frequency spectrum to determine wind speed. In the data of the following sections, range bins of 512 samples are used with range bins overlapped by 50% to give line-of-sight wind

measurements every 76.8-m with 1-m/s speed resolution. Different pulse accumulation times are used depending on the measurement application. Multiple azimuths and associated line-of-sight wind measurements can be combined to find the horizontal wind vector as a function of altitude. All of the processing and wind data display is done in real time for immediate observation by an operator.

The lidar transmitter is housed in a sealed enclosure purged with dry air. The overall dimension of the system enclosure is 67cm X 16.5cm X 26cm. It houses the optical bench which is populated on both sides. The oscillator and the amplifier are mounted on one side and local oscillator associated optics, and the receiver detectors on the other. The bench is temperature controlled to avoid any thermal induced misalignment. All the optical mounts are designed to be adjustable, lockable and hardened to withstand vibrations that can occur in ground or airborne operation.

Table 1. Specifications of lidar.

| Parameter              | Value  |
|------------------------|--|
| Laser material         | Ho:Tm:LuLiF                                    |
| Pulse energy           | 250 mJ   |
| Pulse width            | 200 ns   |
| Pulse repetition rate  | 10 Hz  |
| Spectrum               | Single frequency                               |
| Wavelength             | 2053.5 nm                                      |
| Beam quality ( $M^2$ ) | < 1.3 times diffraction limit                  |
| Detector               | InGaAs in dual-balanced configuration          |
| Telescope aperture     | 15 cm  |
| Scanner                | 8.5 inch aperture, full hemispherical coverage |
| Signal processing      | 500 Ms/s, 8-bits, real-time computation        |
| Range resolution       | 153-m, overlapped 50%                          |
| Velocity resolution    | 1-m/s line of sight                            |

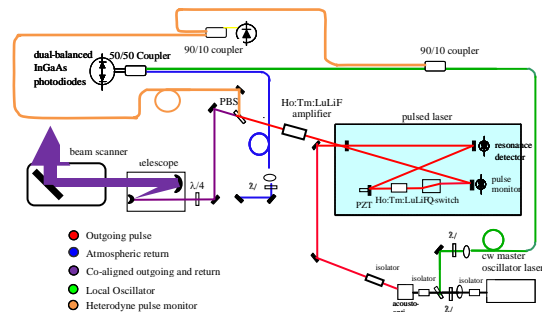

Fig. 1. Layout of the lidar.

### 3. FIELD TEST SITE

The lidar is housed within a mobile trailer designed for field testing. Tests were conducted at a site run by Howard University in Beltsville, Maryland (39.05 N, 76.88 W) [8]. After the 180-mile trip from the lidar's home base in Hampton, Virginia the lidar transceiver maintained alignment. No adjustments to the lidar transceiver were needed over 5 weeks of measurements. Further alignment checks were made after the lidar's return home, again showing no degradation in optical alignment. This resistance to misalignment bodes well from the ultimate application of the lidar in which it will be installed in an aircraft. The test site was chosen for its accommodation of multiple visiting lidars and possession of many other meteorological sensors including wind measuring balloon sondes, sonic and propeller anemometers mounted on a tower, and a 915-MHz radio acoustic sounding system. Figure 2 shows a photograph of the lidar trailer, called VALIDAR, next to the Goddard Lidar Observatory for Wind (GLOW). GLOW is a 355-nm direct detection Doppler wind lidar. Joint measurements of the 2- $\mu$ m coherent and 355-nm direct detection wind lidars were performed.



Fig. 2. Photograph of field test site at the Howard University Research Campus in Beltsville, Maryland. The 2- $\mu$ m lidar is housed within a 35-foot long trailer testbed called VALIDAR. The other trailer houses the Goddard Lidar Observatory for Wind.

### 4. HORIZONTAL AND VERTICAL WIND PROFILING

The horizontal wind vector is measured by steering the lidar beam to two perpendicular azimuths at a fixed elevation angle. Each azimuth angle is

calibrated to a compass heading. With the wind speed versus altitude measured along both directions, the horizontal wind vector can be determined by vector summing the two components. The elevation angle is set at 45 degrees. 250 pulses were averaged at each azimuth. The beam was then steered toward a zenith view to measure the vertical wind with 250 pulses. This combination of horizontal and vertical wind measurement takes 3-minutes to complete for pulse accumulation and time for the beam scanner to move. The lidar signal processing computer repeats this scan pattern and records atmospheric data over a user-selected span, such as in the examples shown in Figure 3.

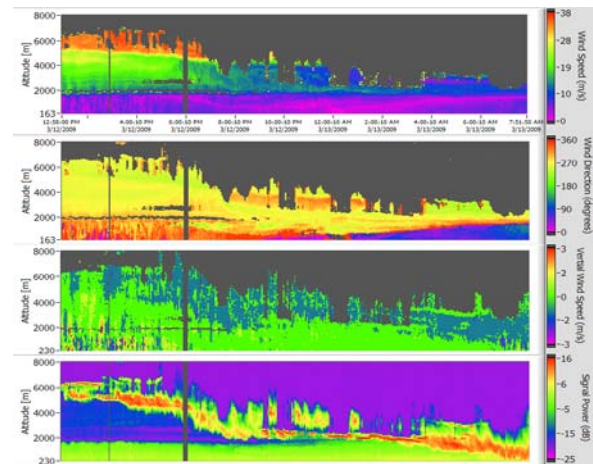

Fig. 3. Wind measurements made from a ground-based lidar during field testing in Beltsville, MD on March 12, 2009. The panels of data show, from top to bottom, the horizontal wind speed, the horizontal wind direction, the vertical wind speed, and signal power. The signal power panel indicates the presence of clouds and the relative density of aerosols. In this data set there is a complex cloud structure that comes to a very low cloud cover toward the end of the set. Despite the low cloud cover, wind measurements are made to an altitude of over 2-km. Throughout the 2nd half of this data set, a frontal system passed through bringing rain—evidence of rain can be seen in the vertical wind motion. Features of interest are circled: (a) atmospheric boundary layer turbulence during daylight hours, (b) speed wind shear between the atmospheric boundary layer and free troposphere, (c) directional wind shear between the atmospheric boundary layer and free troposphere, (d) change in wind direction as a frontal system passes through.

### 5. COMPARISON OF LIDAR AND BALLOON SONDE

Testing of the lidar also included measurements coincident with the launch of GPS balloon sondes. The balloon sonde provides correlated measurement with which to compare wind measurements and

serves to demonstrate the lidar against a sensor that is widely used in the meteorological community. The balloons were Vaisala Radiosonde RS92 released approximately 1-km away from the lidar's location.

Four balloon launches were made on different days in February through March 2009. Figure 7 shows an example of one launch with the lidar and sonde results plotted together. The lidar measurements are in the same 3-minute scan pattern described in the previous section; though the vertical wind measurement is not used here (balloon sondes do not measure the vertical wind component). The lidar gives wind measurements continuously up to 5.2-km altitude, above which low aerosol backscatter begins to inhibit wind measurements.

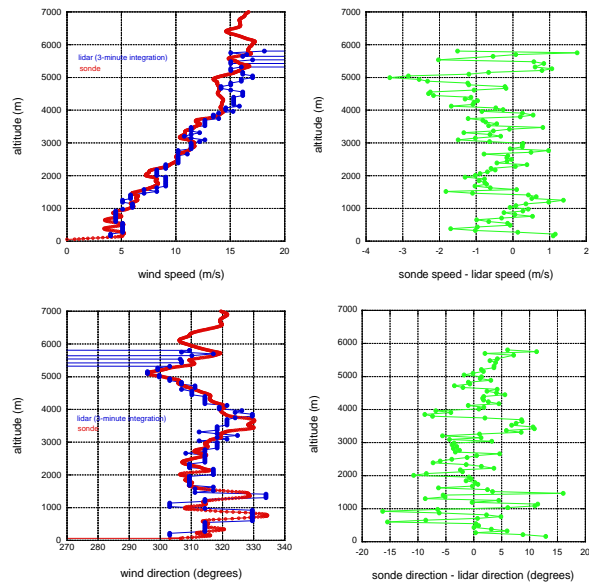

Fig. 4. Lidar and wind measurements co-plotted (left column) and residuals (right column).

The atmospheric boundary layer is evident in both measurements from the relatively low wind speeds at directions that change quickly with altitude below 1.5 km.

To assess the agreement between the two sensors, the difference between the sonde and lidar are also plotted in Figure 4. Specific range interval was used in the plots shown in Fig 4 to calculate a root-mean-square of the residuals gives 1.06-m/s for wind speed and 5.78-degrees for wind direction. In comparing the two sensors, there are several differences in their characteristics that must be taken into consideration. First, the balloon takes a long time compared to the lidar to measure a profile. With a typical ascent rate of 5-m/s, for a balloon to reach 5-km altitude would

take over 16 minutes. The lidar, on the other hand, creates a profile in a much shorter time (3-minutes in the scan format used here). In the comparison shown here the lidar profile used was recorded at the same time that the balloon was released. The balloon measurements at higher altitudes may occur at a time significantly later enough that the wind has changed. Second, the two sensors don't represent the same volume. The balloon is an *in-situ* sensor sampling a point at a time. The lidar represents a conical volume created as the beam is scanned in azimuth and uses a bin of range (153-m long in these measurements) to calculate a line-of-sight wind. Third, the balloon travels with the horizontal wind and travels over a different geographical point as it ascends. The lidar, in contrast, stays at the same point. Hence the differences found between the lidar and sonde of 1.06-m/s and 5.78-degrees have significant contributions from wind variation in time and over space aside from error sources from either sensor.

## 6. CONCLUSION

Field tests have shown the maturation of high pulse energy 2- $\mu$ m Doppler lidar. The lidar transceiver has been packaged in a rugged enclosure that withstands the vibration of transporting the instrument, temperature variation in a field environment, and operation without an operator present. Its 250-mJ output pulse energy gives wind measurements well into the free troposphere. The highest altitude at which horizontal wind measurements were made from aerosol backscatter ranged from a minimum of 5-km to a maximum 8.5-km over tests conducted in February and March 2009. While the tests conducted here were from the ground, the technology development goal is to make measurements from an aircraft. The transceiver described here is being integrated with a telescope and scanner in a vibration isolated; temperature controlled, and hermetically sealed enclosure for installation in aircraft. Preparations are underway to integrate this lidar system on DC-8 aircraft for participation in NASA Genesis and Rapid Intensification Processes (GRIP) hurricane field experiment during summer of 2010. If available, the results from GRIP campaign will be presented.

## 7. REFERENCES

[1] G.J. Koch, J.Y. Beyon, B.W. Barnes, M. Petros, J. Yu, F. Amzajerdian, M.J. Kavaya, and U.N. Singh, "High-Energy 2- $\mu$ m Doppler Lidar for Wind Measurements," *Optical Engineering* **46(11)**, 116201-1 to 116201-14 (2007)