

Data Acquisition and Processing System for Airborne Wind Profiling with a Pulsed, 2-Micron, Coherent-Detection, Doppler Lidar System

J. Y. Beyon, G. J. Koch, and M. J. Kavaya

NASA Langley Research Center
5 North Dryden Street, MS 488
Hampton, VA 23681, USA

Abstract - A data acquisition and signal processing system is being developed for a 2-micron airborne wind profiling coherent Doppler lidar system. This lidar, called the Doppler Aerosol Wind Lidar (DAWN), is based on a Ho:Tm:LuLiF laser transmitter and 15-cm diameter telescope. It is being packaged for flights on-board the NASA DC-8, with the first flights in the summer of 2010 in support of the NASA Genesis and Rapid Intensification Processes (GRIP) campaign for the study of hurricanes. The data acquisition and processing system is housed in a compact PCI chassis and consists of four components such as a digitizer, a digital signal processing (DSP) module, a video controller, and a serial port controller. The data acquisition and processing software (DAPS) is also being developed to control the system including real-time data analysis and display. The system detects an external 10 Hz trigger pulse and initiates the data acquisition and processing process, and displays selected wind profile parameters such as Doppler shift, power distribution, wind directions and velocities. Doppler shift created by aircraft motion is measured by an inertial navigation/GPS sensor and fed to the signal processing system for real-time removal of aircraft effects from wind measurements. A general overview of the system and the DAPS as well as the coherent Doppler lidar system is presented in this paper.

I. INTRODUCTION

The Doppler Aerosol Wind (DAWN) AIR project is funded by the NASA SMD Airborne Instrument Technology Transition (AITT) and Instrument Incubator Program (IIP) as an earth science research tool and a precursor to a space-based wind measurement mission. The backbone of the sensor is a 2-micron pulsed coherent Doppler lidar system that comprises a transceiver, a telescope, a scanner, a thermal management system, control electronics, and a data acquisition, processing, and display system (DAPDS). The system will be ready for integration to the Dryden Flight Research Center (DFRC) DC-8

airborne laboratory in summer 2010. The objective of the project is to perform vertical profiling of wind below the DC-8 while data acquisition, processing, and display occur simultaneously.

2-micron wavelength lasers have been under development for many years at NASA Langley Research Center, most recently under the NASA Laser Risk Reduction Program (LRRP) [1, 2]. The laser and optical portion for this project were completed under a 2004 IIP. A diode-pumped Ho:Tm:LuLiF laser forms the transmitter for the lidar, including an optical amplifier to boost the pulse energy to 250-mJ at 10-Hz pulse repetition rate and 200-ns pulsewidth. Frequency control is created by using a continuous-wave Ho:Tm:YLF laser to injection seed the pulsed laser and serve as a local oscillator. Construction of the transmitter and receiver, the combination of which is called a transceiver, was done with an aircraft environment in mind so that mounting of the optical components is done with immunity to vibration. The packaged transceiver was tested in a ground-based field measurement to verify its performance [3]. The transceiver is currently being combined with a telescope, scanner, electronics, and processing system for installation in the NASA DC-8.

The data acquisition and processing subsystem is very important for a pulsed, coherent-detection, Doppler, wind-profiling lidar system. The parameters of this subsystem determine the range of regard, the allowed span of wind velocities, the range and velocity resolutions, and the velocity interval between calculated points. If this subsystem is not fast enough, either real-time calculation and display, or measurement temporal resolution must be sacrificed.

The project requires acquisition of 55,000 lidar return samples at 10 Hz rate while accumulating 20 pulses at each look direction. The laser beam is directed to five different look directions to correlate the measurements to provide wind profile parameters such as wind direction, wind speed, power distribution, and Doppler shift. The DAPDS is responsible for data acquisition up to output product display while controlling the scanner to point the laser beam to each user-defined look direction. The DAPDS has to overcome the large amount of computationally intensive data processing overhead and it accomplishes it by means of optimization of data transfer and processing. A general overview of the system and its software is presented in latter sections



Fig. 1. Dryden Flight Research Center's (DFRC's) DC-8 Airborne Laboratory

II. DATA ACQUISITION, PROCESSING, AND DISPLAY SYSTEM (DAPDS)

The DAPDS acquires lidar return data, processes them to estimate wind parameters, and displays them using graphs and charts real time. It consists of the INS/GPS Subsystem (IGSS), the Scanner Control Subsystem (SCSS), the Digitizer Subsystem (DSS), and the Digital Signal Processing Subsystem (DSPSS). The challenge in its design is to perform all series of tasks within the time margin determined by an external TTL trigger pulse rate.

Figure 2 illustrates the organization of the DAPDS, where the type of connections is shown by arrows. The thickness of the arrows indicates the relative bandwidth and data throughput. The Core Control Subsystem (CCSS) runs the Data Processing Software

(DPS) in the environment of Windows XP operating system. The DAPDS is built in a compact PCI chassis, which will be integrated in a DC-8 medium-size pallet for a hurricane campaign in summer 2010. The subsystems are built from commercially available off-the-shelf equipment such as Agilent digitizer, BittWare TigerSharc DSP, Kontron serial/video cards and CPU. All components are carefully integrated so that there is no conflict between the drivers and functionalities. Figure 3 shows the photo of the pallet with the DAPDS and laser control electronics all integrated. The rack will be situated in the cabin area while there will be connections running from another pallet in the cargo area below.

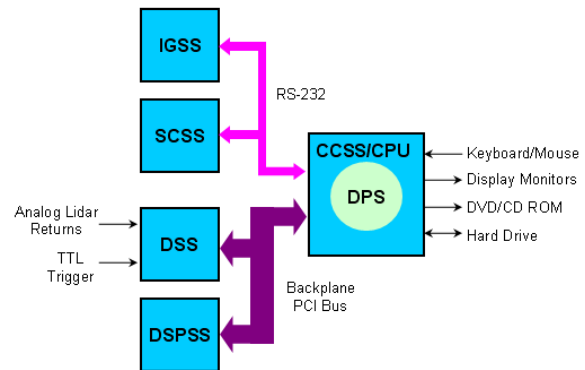

Fig. 2. Data Acquisition, Processing, and Display System (DAPDS)



Fig. 3. DC-8 medium-size pallet for Electronics and DAPDS

III. DATA PROCESSING SOFTWARE (DPS)

The DPS is written in ANSI C using the GUI and serial libraries provided by National Instruments while the DSP target code is written in VisualDSP++ by Analog Devices. The DPS utilizes multithreading in

order to use the CPU time efficiently and to reserve CPU time for time-critical processes. There are five control modules in the DPS: INS/GPS Control Module (IGCM), Scanner Control Module (SCCM), Digitizer Control Module (DCM), Digital Signal Processing Control Module (DSPCM), and Graphical User Interface Control Module (GUICM). Figure 4 illustrates the conceptual organization of the DPS.

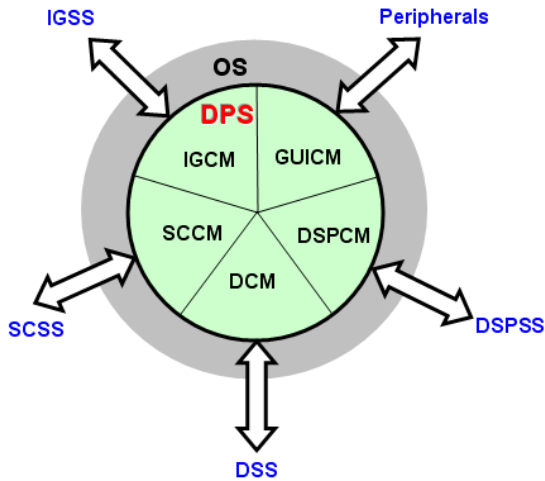

Fig. 4. Data Processing Software (DPS)

The IGCM controls the C-MIGITS INS/GPS unit by Systron Donner, which provides the GPS information of the laser beam. The SCCM controls the scanner controller by Newport Corp., which controls the look direction of the laser beam. The DCM is responsible for the sampling of lidar returns using the external trigger at 10 Hz. The digitizer samples lidar returns at 500 MHz sampling rate triggered by the 10 Hz TTL pulse. It operates at 10-bit resolutions with the bandwidth of 1 GHz for 50 Ohm input impedance. The DSPCM manages the data transfer between the host and the target while performing FFT on the lidar returns. The requirement is to sustain 10 Hz trigger rate without affecting the quality and the processing time of the wind parameter estimates. The BittWare TigerSharc DSP card offers 8-DSP processing power running at 600 MHz with 1.67 ns instruction rate of DSP core. As a result of the implementation of improved data transfer topology and upgraded DSP chips, the worst processing time of two-hundred and ninety three 512-FFT routines was measured at 47 msec and of two-hundred and nine 512-FFT routines at 32 msec. The DAWN AIR project requires the

trigger rate of 10 Hz, which is equivalent of 100 ms interval between two consecutive data acquisition incidents. This is a big improvement in data processing speed, which in turn provides more room for optimization of the other control modules.

IV. CONCLUSION

An overview of the DAWN AIR project and its data acquisition, processing, and display system (DAPDS) and software DAPS is presented. The DAPDS integrates a variety of off-the-shelf equipment to acquire lidar returns, process them, and display the wind parameter estimates. The system is optimized so that every subsystem functions with the others without any resource conflict. The DAPS consists of modules that control different subsystems and wind parameter estimate displays. It constantly monitors the health of the DAPDS and recovers minor errors automatically or alert the operator to attend to significant problems. Its control modules are carefully designed and integrated in order to meet the project requirement in data processing speed and output product. The DAPS can acquire 55,000 – 75,000 lidar return samples, perform 209 – 293 512-point FFT routines and numerical analysis routines at the rate of 10 Hz. The first airborne flight demonstration is scheduled in summer 2010 as part of the GRIP campaign.

ACKNOWLEDGMENT

The authors are very grateful for the support received from the NASA Earth Science Technology Office, from the NASA Science Mission Directorate Earth Science Division, and from NASA Langley Research Center.

REFERENCES

- [1] G.J. Koch, J.Y. Beyon, B.W. Barnes, M. Petros, J. Yu, F. Amzajerdian, M.J. Kavaya, and U.N. Singh, "High-Energy 2-um Doppler Lidar for Wind Measurements," *Optical Engineering* 46(11), 116201-1 to 116201-14 (2007).
- [2] J. Yu, B.C. Trieu, E.A. Modlin, U.N. Singh, M.J. Kavaya, S. Chen, Y. Bai, P.J. Petzar, "1 J/pulse Q-switched 2 um solid-state laser," *Optics Letters* 31, 462-462 (2006).
- [3] G.J. Koch, J.Y. Beyon, P.J. Petzar, M. Petros, J. Yu, B.C. Trieu, M.J. Kavaya, U.N. Singh, E.A.

Modlin, B.W. Barnes, and B.B. Demoz, "Field Testing of a High-Energy 2-um Doppler Lidar," *Journal of Applied Remote Sensing* 4, 043512 (2010).