

NASA/TM—2010–216431



Cost Estimate for Molybdenum and Tantalum Refractory Metal Alloy Flow Circuit Concepts

*R.R. Hickman, J.J. Martin, G.R. Schmidt, and T.J. Godfroy
Marshall Space Flight Center, Marshall Space Flight Center, Alabama*

*A.J. Bryhan
Minimal Technology, Inc., San Jose, California*

May 2010

The NASA STI Program...in Profile

Since its founding, NASA has been dedicated to the advancement of aeronautics and space science. The NASA Scientific and Technical Information (STI) Program Office plays a key part in helping NASA maintain this important role.

The NASA STI Program Office is operated by Langley Research Center, the lead center for NASA's scientific and technical information. The NASA STI Program Office provides access to the NASA STI Database, the largest collection of aeronautical and space science STI in the world. The Program Office is also NASA's institutional mechanism for disseminating the results of its research and development activities. These results are published by NASA in the NASA STI Report Series, which includes the following report types:

- **TECHNICAL PUBLICATION.** Reports of completed research or a major significant phase of research that present the results of NASA programs and include extensive data or theoretical analysis. Includes compilations of significant scientific and technical data and information deemed to be of continuing reference value. NASA's counterpart of peer-reviewed formal professional papers but has less stringent limitations on manuscript length and extent of graphic presentations.
- **TECHNICAL MEMORANDUM.** Scientific and technical findings that are preliminary or of specialized interest, e.g., quick release reports, working papers, and bibliographies that contain minimal annotation. Does not contain extensive analysis.
- **CONTRACTOR REPORT.** Scientific and technical findings by NASA-sponsored contractors and grantees.
- **CONFERENCE PUBLICATION.** Collected papers from scientific and technical conferences, symposia, seminars, or other meetings sponsored or cosponsored by NASA.
- **SPECIAL PUBLICATION.** Scientific, technical, or historical information from NASA programs, projects, and mission, often concerned with subjects having substantial public interest.
- **TECHNICAL TRANSLATION.** English-language translations of foreign scientific and technical material pertinent to NASA's mission.

Specialized services that complement the STI Program Office's diverse offerings include creating custom thesauri, building customized databases, organizing and publishing research results...even providing videos.

For more information about the NASA STI Program Office, see the following:

- Access the NASA STI program home page at <http://www.sti.nasa.gov>
- E-mail your question via the Internet to help@sti.nasa.gov
- Fax your question to the NASA STI Help Desk at 443-757-5803
- Phone the NASA STI Help Desk at 443-757-5802
- Write to:
NASA STI Help Desk
NASA Center for AeroSpace Information
7115 Standard Drive
Hanover, MD 21076-1320

NASA/TM—2010–216431



Cost Estimate for Molybdenum and Tantalum Refractory Metal Alloy Flow Circuit Concepts

*R.R. Hickman, J.J. Martin, G.R. Schmidt, and T.J. Godfroy
Marshall Space Flight Center, Marshall Space Flight Center, Alabama*

*A.J. Bryhan
Minimal Technology, Inc., San Jose, California*

National Aeronautics and
Space Administration

Marshall Space Flight Center • MSFC, Alabama 35812

May 2010

The Prometheus Nuclear Systems and Technology (PNST) Program was restructured to support the timely development of the new crew exploration vehicle and to reflect near-term technology development priorities for lunar exploration. The PNST Program is now focused on research and development that addresses key, high-priority, long-lead nuclear systems and technology issues. Work with the Naval Reactors Prime Contract Team was terminated. The redirected effort includes Glenn Research Center, Marshall Space Flight Center, and the Department of Energy Laboratories and is managed from NASA Headquarters.

TRADEMARKS

Trade names and trademarks are used in this report for identification only. This usage does not constitute an official endorsement, either expressed or implied, by the National Aeronautics and Space Administration.

Available from:

NASA Center for AeroSpace Information
7115 Standard Drive
Hanover, MD 21076-1320
443-757-5802

This report is also available in electronic form at
<<https://www2.sti.nasa.gov>>

TABLE OF CONTENTS

1. INTRODUCTION	1
1.1 Design Basis of Cost Estimate	2
1.2 Candidate Refractory Materials	2
1.3 Candidate Liquid Metal	4
2. FLOW CIRCUIT ESTIMATES FOR Mo-47.5%Re SELECTION	5
2.1 Material Considerations	5
2.2 Fabrication Considerations	11
3. FLOW CIRCUIT ESTIMATES FOR TANTALUM ALLOY SELECTION	18
3.1 Material Considerations	18
3.2 Fabrication Considerations	21
4. LIQUID-METAL PUMP	25
4.1 Electromagnetic Conduction Pumps	25
4.2 Electromagnetic Induction Pumps	25
4.3 Pump Selection	26
5. INSTRUMENTATION CONSIDERATIONS	27
5.1 Temperature Measurement	27
5.2 Pressure Measurement	27
5.3 Flow Measurement	28
6. GENERAL ASSEMBLY, INTEGRATION, AND OPERATION	31
6.1 Operational Environment	31
6.2 Assembly and Facilities Integration	31
6.3 Circuit Operations	33
7. SUMMARY	37
APPENDIX—ALKALI METAL FLOW CIRCUIT ENGINEERING DRAWINGS	39
REFERENCES	42

LIST OF FIGURES

1.	ReLiC design basis schematic	3
2.	Three-dimensional SLiC rendering	3
3.	DBTT as a function of Re content for Mo-Re alloys	5
4.	DBTT versus oxygen, nitrogen, and carbon content for Mo	7
5.	UTS versus temperature for Mo and Mo alloys	9
6.	UTS for PM Mo-41%Re, 44.5%Re, 47.5%Re, and 51%Re at 273, 1,073, and 1,473 K	9
7.	Percent elongation for Mo-41%Re, 44.5%Re, 47.5%Re, and 51%Re at 273, 1,073, and 1,473 K	10
8.	Stress for 1% creep in 61,000 hr versus temperature	10
9.	Mo-41%Re parts machined from arc-cast material for the AMTEC system	15
10.	Varestraint test results rank cracking sensitivity exactly as observed in plate welding	22
11.	EM-style flowmeter	29
12.	Orifice plate-style flowmeter	29
13.	Flow circuit assembly drawing set 90M11881 (latest update 11-12-2004)	40

LIST OF TABLES

1.	Target chemical composition of Mo-47.5%Re	8
2.	Bulk materials summary	11
3.	Mo-Re material vendors capability	12
4.	Cost and time estimates for an Mo-47.5%Re circuit	16
5.	Estimated fabrication schedule for an Mo-47.5%Re circuit	17
6.	Chemical analysis of T-111 and ASTAR-811C	19
7.	Bulk materials summary for flow circuit	20
8.	Tantalum material vendors capability	21
9.	Cost and time estimates for a Ta alloy circuit	23
10.	Estimated fabrication schedule for a Ta alloy circuit	24

LIST OF ACRONYMS AND SYMBOLS

AC	alternating current
ALIP	annular linear induction pumps
AMM	Advanced Methods and Materials
AMTEC	alkali metal thermal-to-electric
Ar	argon
ASTM	American Society for Testing of Materials
B	baron
C	carbon
Ca	calcium
CAD	computer-aided design
CEI	Creative Engineers, Inc.
CIP	centrifugal induction pump
Co	cobalt
Cu	copper
DBTT	ductile-to-brittle transition temperature
DC	direct current
DCSP	direct current straight polarity
DOE	Department of Energy
EB	electron beam
EDM	electric discharge machining
EM	electromagnetic
Fe	iron
FLIP	flat linear induction pump
GHe	gaseous helium
GN ₂	gaseous nitrogen
GTA	gas tungsten arc

LIST OF ACRONYMS AND SYMBOLS (Continued)

H	hydrogen
HAZ	heat-affected zone
He	helium
Hf	hafnium
HIP	helical induction pump
HX	heat exchanger
Li	lithium
Mg	magnesium
Mn	manganese
Mo	molybdenum
MSFC	Marshall Space Flight Center
N	nitrogen
Na	sodium
NaK	sodium-potassium
Nb	niobium
NDE	nondestructive evaluation
Ni	nickel
NRPCT	Naval Reactors Prime Contract Team
O	oxygen
ORNL	Oak Ridge National Laboratory
PM	powder metallurgy
PMTI	Pittsburgh Materials Technologies, Inc.
Re	rhenium
ReLiC	refractory metal lithium circuit
ROM	rough order of magnitude
RT	room temperature
Si	silicon

LIST OF ACRONYMS AND SYMBOLS (Continued)

SLiC	stainless steel lithium circuit
Sn	tin
SP-100	Space Power-100
SS	stainless steel
Ta	tantalum
TC	thermocouple
TM	Technical Memorandum
UHV	ultrahigh vacuum
U.S.	United States
USGS	U.S. Geological Survey
UTS	ultimate tensile strength
W	tungsten
Zr	zirconium

NOMENCLATURE

C_p	specific heat
$C_{p-alkali}$	specific heat of the alkali metal
\dot{m}_{alkali}	alkali-metal cooling flow
$\dot{m}_{coolant}$	mass flow rate
Q_{fluid}	coolant flow
T_{in}	inlet temperature
$T_{in-alkali}$	inlet temperature of the alkali metal flow
T_{out}	outlet temperature
$T_{out-alkali}$	outlet temperature of the alkali metal flow

TECHNICAL MEMORANDUM

COST ESTIMATE FOR MOLYBDENUM AND TANTALUM REFRACTORY METAL ALLOY FLOW CIRCUIT CONCEPTS

1. INTRODUCTION

The United States is again interested in developing and utilizing a nuclear power and propulsion system in space. This is the third such attempt, the first being in the 1960s through 1970s and the second being the Space Power-100 (SP-100) Program from the late 1980s through 1993. Consideration of experience gained from the SP-100 Program has been included in this Technical Memorandum (TM). It is also expected that much will be learned from the current stainless steel lithium circuit (SLiC) being fabricated by Marshall Space Flight Center (MSFC). The results of this hardware effort, though not specific for refractory metals, will provide an excellent point of departure to more prototypic combinations. It should be noted that SP-100 was designed around niobium (Nb) alloys because they were commercially available and a reasonable knowledge base was assumed to exist. However, many man-hours were spent to augment the knowledge base to successfully build the three Nb alloy loops in that program. A similar approach will be necessary for the successful fabrication of a tantalum (Ta) or molybdenum (Mo) alloy circuit.

Three candidate structural refractory metal alloy families have been identified for study by the Naval Reactors Prime Contract Team (NRPCT) for this circuit: (1) Mo-based, (2) Ta-based, and (3) Nb-based (baseline for the SP-100 Program). The primary focus of this TM is the Mo/rhenium (Re) alloy (Mo-47.5%Re) and Ta alloys (T-111 and ASTAR-811C). The cost to build a new pumped lithium (Li) circuit must include the cost to create a sufficient refractory metal supplier base from which to procure the necessary quality materials. While an attempt will be made to cost the circuit using all available suppliers, there will be practical and technical challenges in meeting both material and fabrication requirements. It is evident that the refractory metal infrastructure from previous space power reactor programs has been diminished. However, there are several companies with the expertise and capabilities to meet the requirements, given adequate cooperation between the refractory metal supplier and circuit designer. It should be noted that fabrication of the outlined refractory metal flow circuit provides a means to develop/capture expertise related to material issues, in addition to establishing a test capability to evaluate components and fluid models for an alkali metal primary heat-transport system.

The SP-100 Program successfully operated three Li loops containing several hundred welds at 1,350 K for a few thousand hours. In quiet support of that effort, however, was the experimentation necessary to develop technically sound fabrication specifications for such items as cleaning and acid pickling, annealing and heat treating, gas tungsten arc (GTA) welding, and electron beam (EB) welding to produce optimum mechanical properties, Li resistance, and nondestructive examination (NDE).

This effort is documented in an SP-100 report by Bryhan,¹ who is a coauthor of this TM and has provided many details from the SP-100 effort.

The cost to produce the Li refractory metal circuit may need to duplicate the SP-100 approach for the selected Mo or Ta material. Beyond the basic fabrication specifications, there was significant experimental materials work performed to produce the optimum flow circuit components including the tubing, joint tees and flanges, Li fill and drain containers/flow systems, refractory metal radiant heaters, etc. In addition, supporting these activities required experimental development of inert atmosphere welding equipment with the capability to monitor/analyze the process. All testing operations made use of very clean vacuum vessels to contain the flow loop for high-temperature evaluation. Details for these subjects are discussed in the remainder of this TM.

1.1 Design Basis of Cost Estimate

This refractory metal Li-flow circuit estimate has been based on the SLiC scheduled for testing at MSFC under an NRPCT task. The original flow circuit layout was a stainless steel (SS) design that made use of a sodium-potassium (NaK) mixture and was funded by the NASA Advanced Technology Program. This design was adapted for use with Li in the current MSFC effort. Engineering drawings for this flow circuit hardware are provided in the appendix; these drawings were used for quotation purposes. This design was chosen simply to provide a starting frame of reference from which to gain an understanding of issues that would be encountered when a refractory metal circuit is designed. Extensive redesign of existing SS components (thicknesses, tolerances, welds, etc.) would be needed to accommodate the to-be-selected circuit material, configuration, and operational requirements. The engineering required to support this type of redesign is also included in the rough order of magnitude (ROM) estimate. It is noted that a wide spectrum of subtle details would need to be addressed once the actual flow circuit design and build is initiated. The current study focuses primarily on the top-level drivers with the understanding that many smaller concerns, not specifically listed, will be accounted for within the ROM estimate as appropriate.

The basic design consists of a series of components including a core segment, heat exchanger (HX), pump, reservoirs, support structures, and instrumentation as shown in figures 1 and 2. The SLiC design nominal operational temperature is 773 K with an operational life of $\approx 1,000$ hr. The next generation refractory metal lithium circuit (ReLiC) would be capable of much higher operating temperatures ($\approx 1,250$ K). Many manufacturing and design decisions are based upon the material selection. For the purpose of this ROM assessment, dimensional constraints of the SS components (i.e., flow annulus dimensions, wall thicknesses, etc.) were used to generate material estimates.

1.2 Candidate Refractory Materials

NRPCT has expressed interest in several candidate refractory metal materials, giving direction to MSFC to perform a top-level study on selected materials, with the result being a cost and schedule ROM estimate. The specified priority ranking of these materials for study purposes is as follows:

- Mo-47.5%Re.
- T-111 (Ta-8%W-2%hafnium (Hf)).

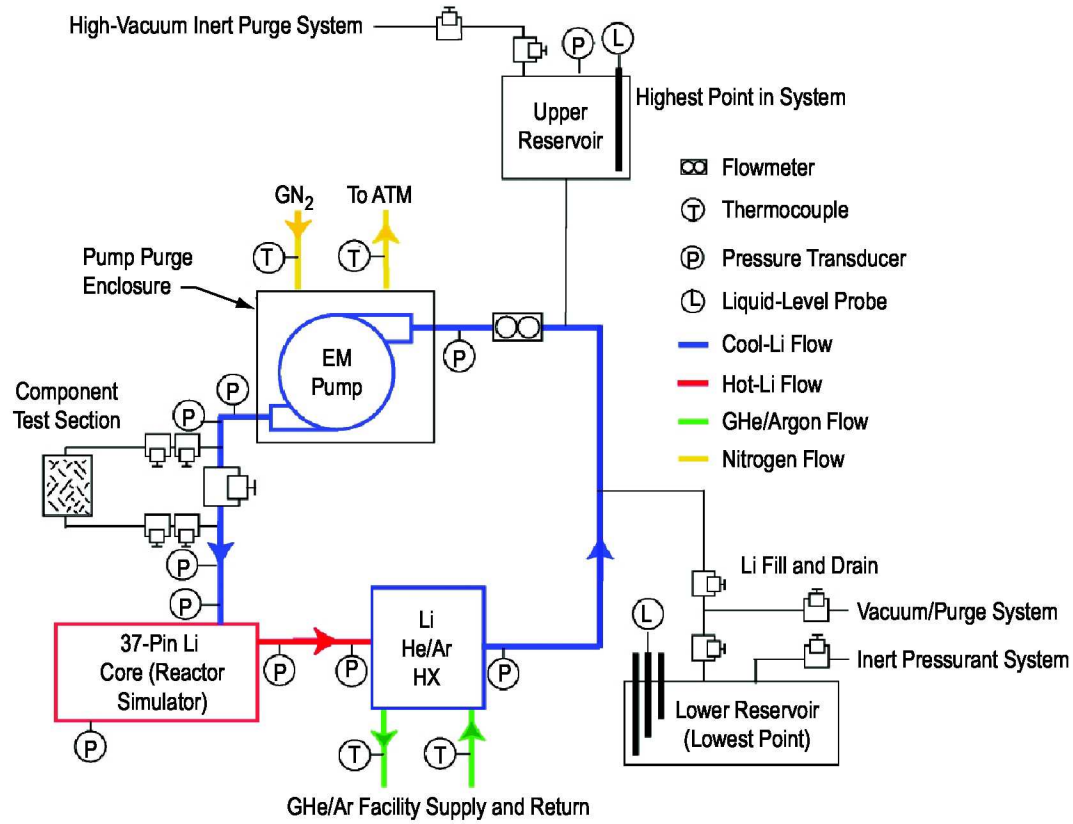

Figure 1. ReLiC design basis schematic.

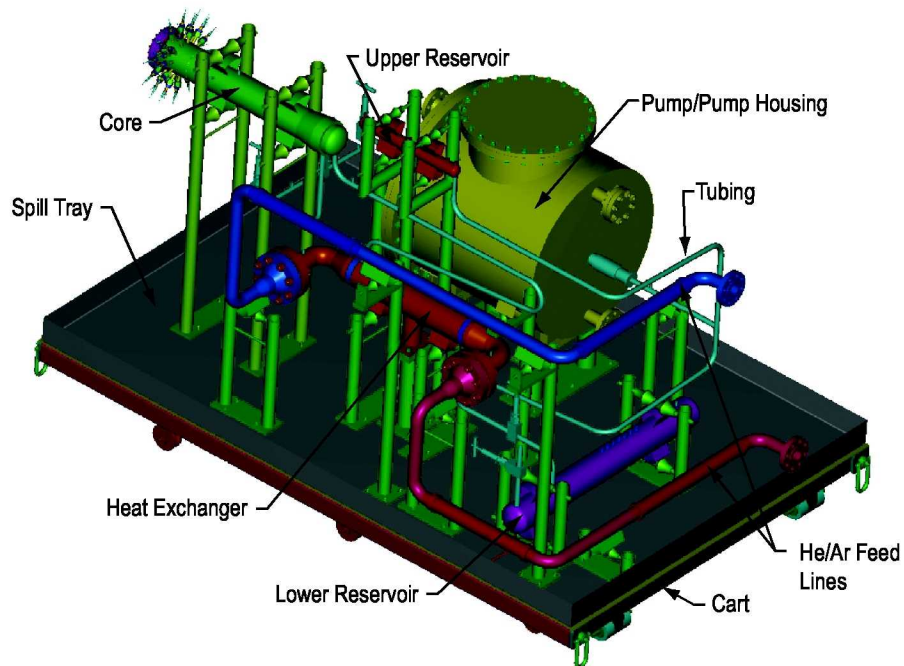

Figure 2. Three-dimensional SLiC rendering.

- ASTAR–811C (Ta-8%W-1%Re-1%Hf-0.025% carbon (C)).
- Nb-1%zirconium (Zr) or PWC–11 (Nb-1%Zr-0.1%C).

The emphasis of the current study is focused on the Mo-47.5%Re, T–111, and ASTAR–811C alloy selections; the Nb alloy will not be investigated.

The Mo-47.5%Re alloy has a good combination of high-temperature strength, ductility, and resistance to oxygen embrittlement. ASTAR–811C is a solid solution and dispersion strengthened alloy that has excellent high-temperature strength.² The main disadvantage for Ta and Nb alloys is a high susceptibility to oxygen contamination. Recent testing in oxygen atmospheres of <5 ppm at 1,198 K showed that Mo-44.5%Re retained ductility at room temperature (RT) with a measured elongation of 19% to 22%, while Nb-1%Zr became brittle with <1% elongation.³ Although Ta alloys are significantly stronger, the Nb alloys have heritage from the SP–100 Program and are well developed with respect to properties and fabrication characteristics. Unlike Mo alloys, complete loops have been fabricated from both Ta and Nb alloys.

1.3 Candidate Liquid Metal

Lithium is the primary candidate alkali metal (as specified by the NRPCT) being considered for all flow circuit materials options due to the high operating temperature requirement. This study assumes that purified bulk Li for the proposed refractory metal flow circuit will be made available from other NRPCT programs and, therefore, is not included as a development effort in this ROM assessment. The SP–100 Program successfully used battery-grade Li (Li>99.8% purity supplied by the Chemetall Company). A purification circuit could be used to process and load the Li; however, it is unlikely to be a necessary requirement to complete this task.

2. FLOW CIRCUIT ESTIMATES FOR Mo-47.5%Re SELECTION

The Mo-Re material estimates are based on the procurement of raw stock and the additional processing/fabrication needed to manufacture components and assemble the liquid metal flow circuit. Both vacuum-arc casting and powder metallurgy (PM) processes were investigated to determine ROM cost/delivery and current fabrication capabilities. Vacuum-arc melting is the preferred process because of high purity, improved welding characteristics, and material property concerns compared to production by PM. As described in the following sections, data from literature suggest a maximum Re content of $\approx 45\%$ for PM material. However, PM Mo-47.5%Re and Mo-44.5%Re are discussed, since both materials are still being developed and the processing property relationships are not well known, especially with respect to high-temperature creep life and weldment performance.

2.1 Material Considerations

The primary concern with Mo-Re alloys for space power applications is their high ductile-to-brittle transition temperatures (DBTTs) following welding or recrystallization. The DBTT is an excellent index to the fabricability of refractory metal alloys. Compositions that exhibit a DBTT at RT and below typically have excellent primary and secondary fabrication characteristics. Alloying of Mo with Re has been investigated extensively to improve low-temperature ductility. It is well documented that additions of Re improve the elevated temperature strength and reduce the DBTT.^{4,5} Molybdenum alloys containing $<15\%$ Re have been previously investigated on space nuclear power programs for fuel claddings and heat pipes.⁶ However, studies show that welding significantly raises the DBTT of Mo-13%Re and Re additions of up to 50 wt.% are needed to retain ductility below RT.⁷ As shown in figure 3, the affects of Re on the low-temperature ductility of Mo are more pronounced with higher Re content, especially for recrystallized or welded material.⁸

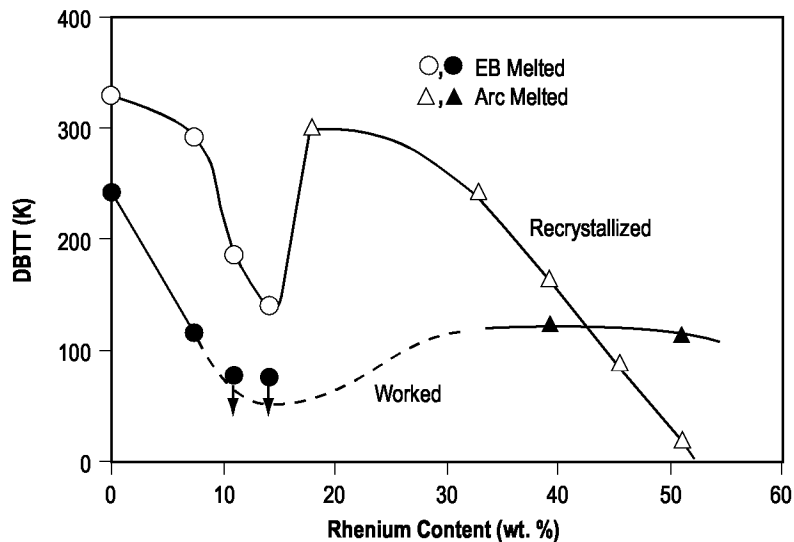

Figure 3. DBTT as a function of Re content for Mo-Re alloys.

Mo-Re alloys are commonly available in three standard compositions: (1) Mo-41.5%Re, (2) Mo-44.5%Re, and (3) Mo-47.5%Re. However, the composition range has not been firmly established with respect to processing and properties. The maximum benefits of Re additions can be obtained at or close to the solubility limit for Re, which is $\approx 46\%$ at 1,373 K.⁹ Because the Re solubility drops with decreasing temperature, alloys containing more than $\approx 45\%$ Re may be subject to precipitation of a hard and brittle sigma phase. Significant amounts of sigma phase can result in loss of ductility, poor machinability, and difficulty in manufacturing. The amount of sigma phase and its influence on mechanical properties is very dependent on the fabrication characteristics. The strength, ductility, and service properties of Mo-Re alloys can also be significantly affected by the chemical purity and the microstructures formed during processing.

2.1.1 Alloy Selection and Processing

Mo-Re alloys have been produced by EB melting, vacuum-arc casting, and PM processes. The initial task in the fabrication of the flow circuit should focus on establishing production capabilities and characterizing the resulting effect on material properties. Much of the early experimental Mo-Re production was performed by either EB or vacuum-arc melting, while current production is dominated by the PM process. Each fabrication method has unique characteristics that can influence residual porosity, impurity segregation, microstructure, and precipitation of sigma phases. Powder metallurgy alloys are generally associated with local nonuniformities in the Re distribution, while vacuum-melted materials have a high degree of uniformity and purity.

Current high Re content Mo alloys are primarily produced using PM sintered billets. The billets can be used for subsequent vacuum remelting and deformation (warm and/or cold working) or they can be worked directly into useable forms. For Re compositions of approximately $>45\%$, sintered billets contain the sigma phase in virtually all cases. The coarsest sigma phase inclusions are contained in sintered billets from a mixture of metallic powders. A more uniform fine distribution of sigma phases can be obtained by using powder produced by cooperative reduction of Mo oxides and ammonium perchlorate. Subsequent repeated deformation with intermediate annealing can increase the uniformity of composition and yield a virtually homogeneous alpha solid solution. However, the sigma phase precipitates are still present in the microstructure. Vacuum-melted Mo-47.5%Re ingots produced by remelting of sintered billets do not contain any sigma phase.¹⁰

The presence of second-phase particles can affect the properties and fracture behavior of Mo-Re alloys. It is readily apparent that ductility is affected by the sigma phase. The presence or precipitation of sigma phases decreases recrystallization and retards the growth of grains as compared to single-phase alloys. The result is an increase in tensile strength and a reduction in ductility. Leonhardt et al. reported an increase in tensile strength and a loss of ductility at RT and 1,473 K for PM Mo-47.5%Re as compared to PM Mo-44.5%Re.¹¹ The presence of random sigma phase was observed for the Mo-47.5%Re, while Mo-44.5%Re was sigma free. Though the RT ductility was not significantly reduced, the high-temperature loss of ductility can reduce the creep life. Klopp reported that unalloyed PM tungsten had one-half the creep rupture life of unalloyed arc-melted tungsten with similar grain sizes.¹² This difference was thought to result from fine particles and impurities in the PM tungsten that reduced the ductility. These observations suggest that it may be wise to limit the Re content of PM alloys to $<45\%$. However, PM Mo-47.5%Re may have more than adequate high-temperature creep life for the alkali metal flow circuit.

2.1.2 Chemical Purity

Purity, with respect to interstitials (oxygen, nitrogen, and carbon) will have a significant effect on the low-temperature ductility and fabricability of Mo alloys. Oxygen is the most embrittling of the impurities and typically is limited to <20 ppm. Figure 4 shows the DBTT as a function of oxygen, nitrogen, and carbon content for pure Mo.⁸ Carbon is the least embrittling and has been reported as an effective deoxidizer for Mo alloys with beneficial effects on fabricability, especially for welding.¹³ Wadsworth et al. reported that carbon-to-oxygen atom ratios >2:1 severely limit oxygen segregation during recrystallization and ductile behavior is observed at RT.¹⁴ At carbon-to-oxygen ratios <2:1, recrystallized Mo exhibited brittle behavior. These issues will have to be thoroughly investigated prior to fabrication with special emphasis on chemistry for comparison of data.

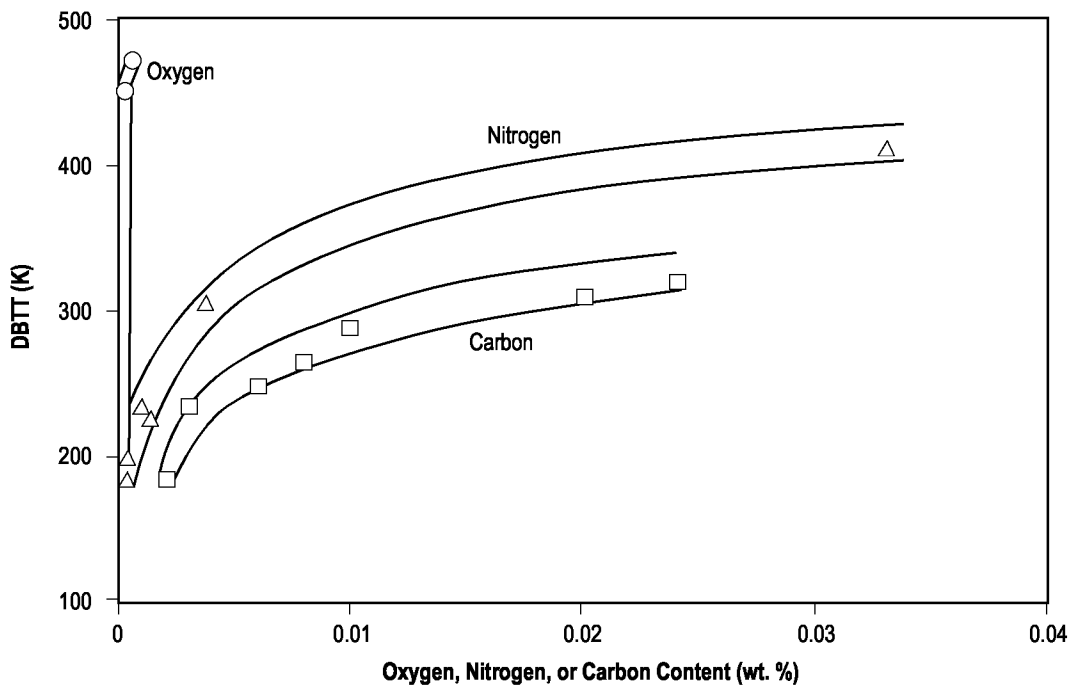

Figure 4. DBTT versus oxygen, nitrogen, and carbon content for Mo.

In general, vacuum melting yields higher purity material, which would be preferred to reduce potential problems with weld embrittlement and liquid-metal corrosion. In fact, data show that the ductility can be improved further by multiple remelting to reduce the levels of metallic impurities such as iron (Fe), aluminum, and silicon (Si). Table 1 lists the target impurity levels for the Mo-Re alloys.

2.1.3 Material Property Summary

There are presently no commercially available Mo-Re alloys that have an established database for designing a space nuclear power reactor. High-temperature material property data on Mo-Re alloys is scarce and scattered in numerous sources. It is recommended that a complete characterization of PM versus arc-cast Mo-Re be performed prior to the material/process downselect. The following is a review of some material properties from literature.

Table 1. Target chemical composition of Mo-47.5%Re.

Element	wppm
O	<10
C	C:O=>2.5:1 (20–30 wppm)
N	<3
H	<1
Ca	<5
Fe	<20
Ni	<20
W	<100
Si	<10
Mg	<10
Mn	<4
Co	<30
Sn	<20
B	<10

Strength and ductility at elevated temperatures for 10 or more years are required for space nuclear reactor materials. Mo-Re alloys have demonstrated good strength at temperatures up to 1,800 K.⁸ Figure 5 shows the ultimate tensile strength (UTS) as a function of temperature for several Mo alloys. As shown, additions of up to 50% Re provide significant strength increases. Figures 6 and 7 show the UTS and percent elongation for PM Mo-41%Re, Mo-44.5%Re, Mo-47.5%Re, and Mo-51%Re at 273, 1,073, and 1,473 K.¹¹ The Mo-41%Re and 44.5%Re materials had good ductility with $\approx 20\%$ elongation at RT and 12% to 14% at 1,473 K. Note that the elongation decreased to $\approx 8\%$ for Mo-47.5%Re and 4% for Mo-51%Re, the result of sigma phases.

The primary strength property for space nuclear reactor materials is resistance to creep deformation. Creep properties of Mo alloys have been studied on numerous programs, but all of the available data is for relatively short times. This leads to long-term creep rate estimates based on extrapolation of the short-term data. Figure 8 shows the density compensated stress for 1% creep strain in 61,000 hr as a function of temperature for various refractory alloys.⁸

2.1.4 Raw Material Cost and Availability

Mo-Re mill products in the form of tubing, plate, and solid round bar stock are required to fabricate the liquid-metal circuit components. These products can be fabricated by rolling, extrusion, swaging, and drawing. Table 2 lists the approximate bulk dimensions and quantities. Round bar stock and seamless tubing are readily available and can be used for liquid-metal piping, bosses, and miscellaneous support fixtures. Thin-plate materials are readily available in 4- to 8-in widths. The most challenging products are 10- to 16-in-wide plate sections that will be used to fabricate 3- and 5-in-diameter pipe sections. Note that the dimensions are approximate and are based on the SS flow circuit currently being assembled at MSFC.

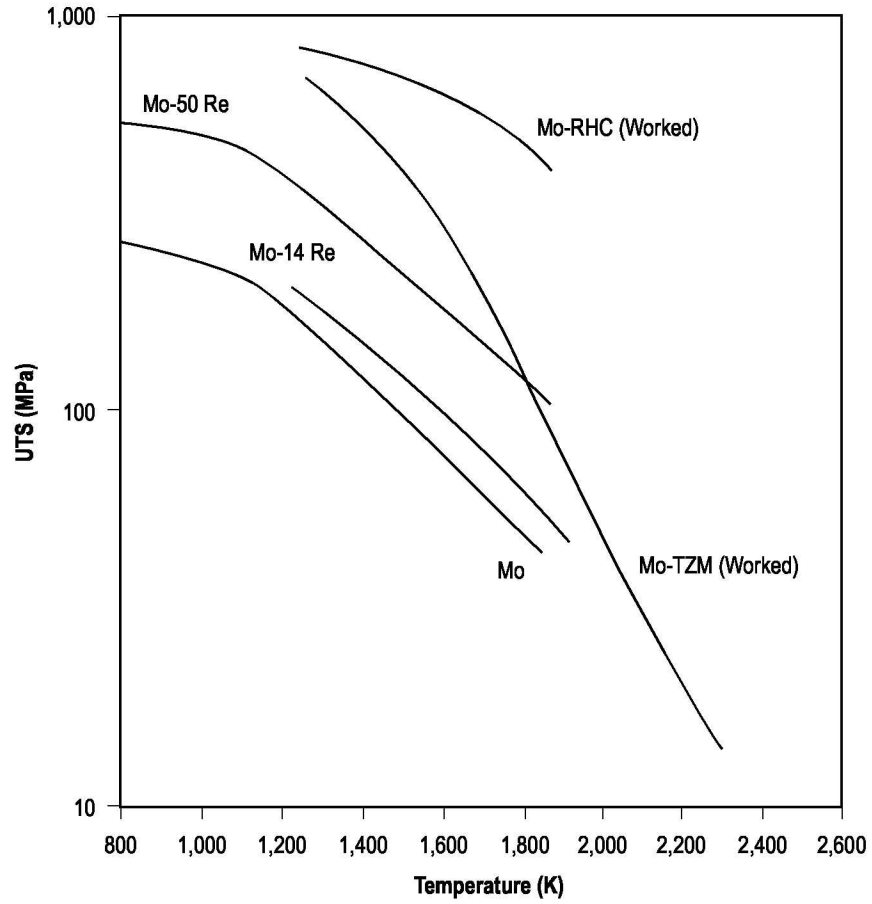

Figure 5. UTS versus temperature for Mo and Mo alloys.

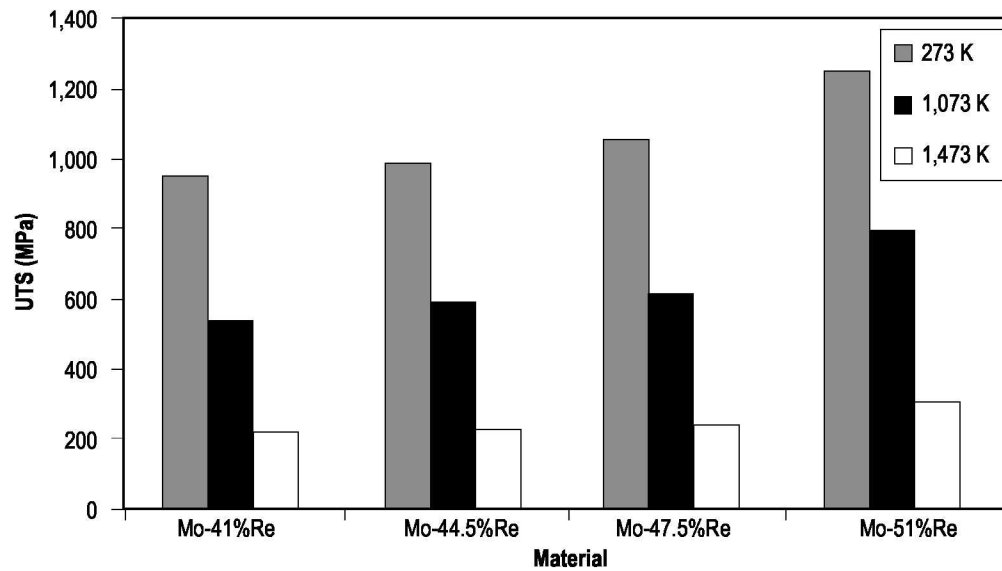

Figure 6. UTS for PM Mo-41%Re, 44.5%Re, 47.5%Re, and 51%Re at 273, 1,073, and 1,473 K.

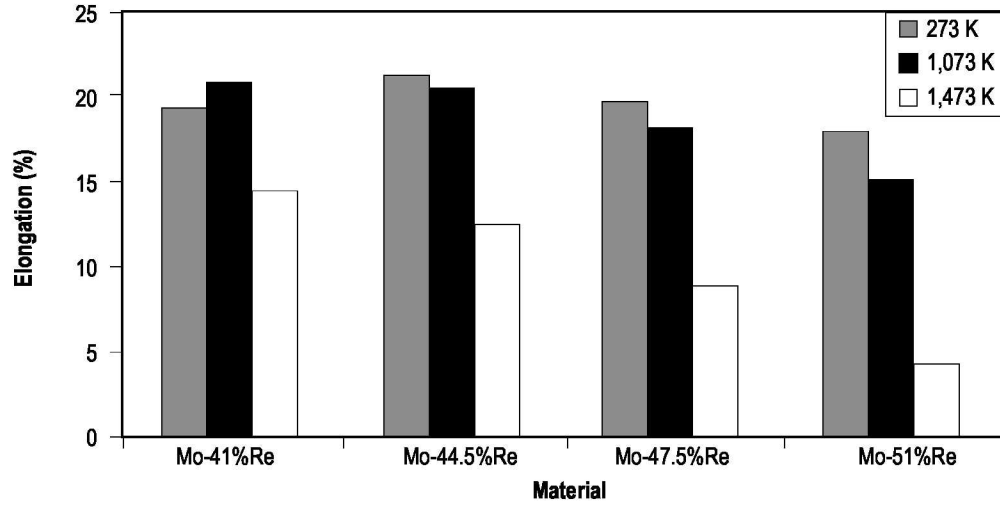

Figure 7. Percent elongation for Mo-41%Re, Mo-44.5%Re, Mo-47.5%Re, and Mo-51%Re at 273, 1,073, and 1,473 K.

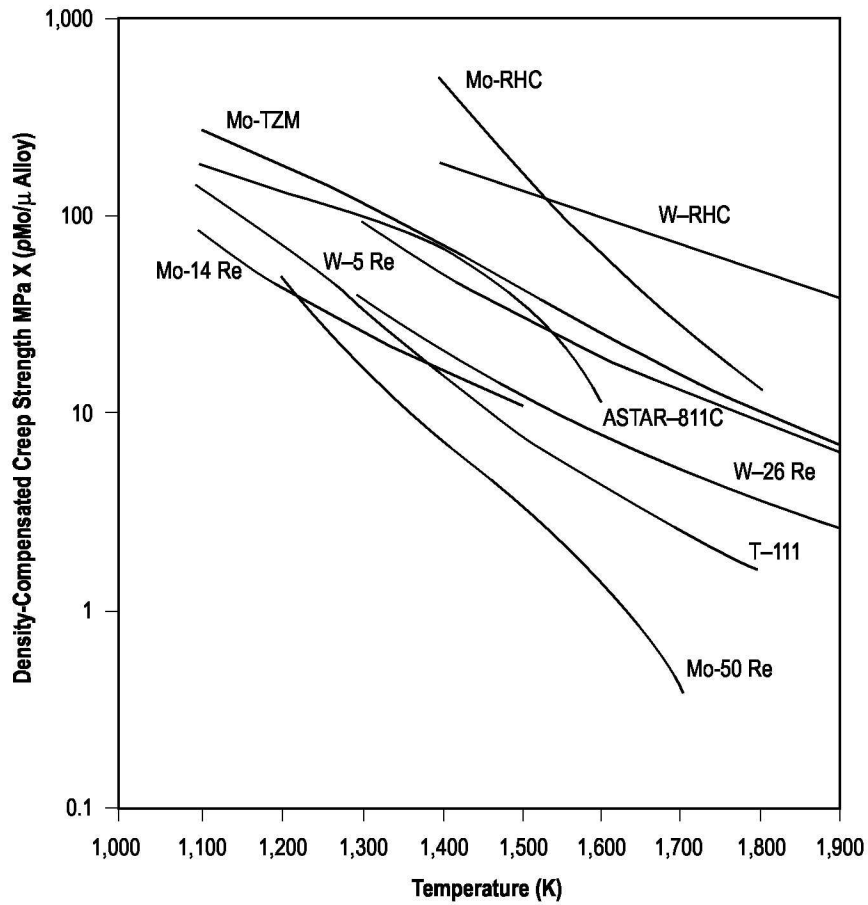

Figure 8. Stress for 1% creep in 61,000 hr versus temperature.

Table 2. Bulk materials summary.

Stock	Dimensions	Quantity	Components
Plate	16 in wide x 0.125 in thick	137 in (12 ft)	5-in OD pipe sections up to 42 in long
Plate	10 in wide x 0.125 in thick	60 in (5 ft)	3-in OD pipe sections up to 27 in long
Plate	1 in thick x 8 in x 8 in	6 pieces	Miscellaneous flanges, plates
Plate	4 in wide x 0.125 in thick	192 in (16 ft)	Formed and machined support structures
Seamless tube	1-in OD x 0.095-in wall	456 in (38 ft)	Miscellaneous piping
Seamless tube	0.5-in OD x 0.035-in wall	1,200 in (100 ft)	Includes 37 26-in-long tubes
Seamless tube	5/16-in OD x 0.035-in wall	2,784 in (232 ft)	Includes 107 26-in-long tubes
Seamless tube	3/16-in OD x 0.035-in wall	36 in (3 ft)	Miscellaneous piping
Round bar stock	1-in OD	36 in (3 ft)	Miscellaneous bosses, pipes, fixtures, etc.
Round bar stock	1.25-in OD	48 in (4 ft)	Miscellaneous bosses, pipes, fixtures, etc.
Round bar stock	5/64-in OD	60 in (5 ft)	Miscellaneous bosses, pipes, fixtures, etc.

As previously noted, PM is by far the most common manufacturing process for current Mo-Re alloy mill products. Sintered PM ingots can be cold formed but are typically hot or warm worked followed by cold rolling with intermediate annealing to final dimensions. In contrast, melted materials require hot extrusion to break down the cast structure. Another significant characteristic of PM processing is the ability to fabricate net-formed structures, such as tube shells. Seamless tubing can be more easily fabricated using the tube shapes. Arc-cast billets require gun drilling prior to drawing, which results in material waste.

Multiple vendors were investigated regarding their ability to provide Mo-Re material. Table 3 lists the vendors, capability, and material costs and availability of the bulk materials. Rhenium Alloys, Inc. was the only company to provide a quote for PM Mo-47.5%Re. Swartzkopf Technologies (Plansee) has demonstrated the capability to fabricate Mo-41%Re by PM processes, but a full quote has not been received to date. Data from recent Mo-41%Re production were provided that compared well to values from literature. Swartzkopf also indicated that Mo-44.5%Re and Mo-47.5%Re could be special ordered, but significant development would be required. Rhenium Alloys, Inc. offers any Mo-Re composition up to 47.5%Re on a custom-order basis. Pittsburgh Materials Technologies, Inc. (PMTI) was the only commercial company found during this initial investigation that will provide arc-cast Mo-47.5%Re. Other large manufacturers of Mo materials such as Wah Chang and H. C. Starck were contacted about special production runs, but there was no interest in fabricating the Mo-Re material at this time. An effort will be required to develop specifications for mill products that will address issues including, but not limited to, grain size, porosity, chemical composition, defects, temper, hardness, and dimensional tolerance.

2.2 Fabrication Considerations

General issues associated with fabricating refractory metal components for containing molten Li involve controlling contamination that might be captured within the metal during welding or might contaminate the surfaces during forming or machining. Welding will likely be performed by GTA and EB processes. Assembly of the bulk components and attachment to piping, flanges, and support structures should be performed using EB welding wherever possible to maximize purity and minimize heat effect. Final assembly of the components and piping will be accomplished using GTA due to the overall

Table 3. Mo-Re material vendors capability.

Vendor/Material	Capability
Rhenium Alloys, Inc. PM Mo-41 to 47.5%Re	Plate up to 10-in width, round bar, up to 1-in-diameter seamless tubing, larger seamless tubing capability currently being developed.
PMTI Arc-Cast Mo-47.5%Re	Small ingots (max. 80 in ³), can produce small rod and plate materials; larger plate and tubing would be subcontracted to vendors.
Schwarzkopf Technologies Corp. (Plansee) Mo-41%Re alloys	Up to 24-in-wide plate capability, round bar, and seamless tubing.
Rembar Company, Inc.	No information provided.
Wah Chang	Mo-Re material not offered.
H. C. Starck	Mo-Re material not offered.
Cabot Super Metals	Mo-Re material not offered.

physical size of the layout. Environmental and process controls will be established and analysis instruments implemented to record/monitor the variables known to influence the structural properties of the final product. These variables include interstitial elements within inert cover gas or vacuum welding and heat-treating systems, chemical cleaning/pickling processes, and the applied strains during mechanical forming.

2.2.1 Welding

Welding characteristics are a strong concern for the fabrication of refractory metal components. Molybdenum and its alloys tend to be significantly less ductile in the as-welded condition. This phenomenon is generally attributed to interstitial impurity segregation to the grain boundaries and to the large recrystallized grain structure. Ductility improvements have been demonstrated for high Re content Mo-Re alloys (>41%Re) but very little property data exist for welded material. MSFC is currently developing EB welding for PM Mo-44.5%Re in support of another NRPCT project for heat pipe lifetime testing. The initial weld development will be based on microstructure, chemistry, and bend testing to determine the DBTT. After optimization of weld parameters, welded axial tensile samples will be tested at RT and 1,473 K. Both transverse and longitudinal weld samples will be tested and compared to the base metal. Postweld annealing will also be investigated to recover material properties.

In general, vacuum-melted materials have better welding characteristics than PM materials because of higher purity. Also, PM materials can evolve gas during welding, which can result in porosity. Environmental control during welding is critical to reduce interstitial impurities. This is true for both GTA welding under an inert atmosphere as well as EB welding. Since EB welding is performed in a vacuum, it might be assumed that there is less opportunity for contamination. That said, both the vacuum chamber and inert environments must be monitored for gas species and off-gassing of moisture, as even low levels of oxygen, nitrogen, and water vapor can influence refractory metal properties. The surfaces of the parent metal and filler metal should be degreased and chemically cleaned prior to welding. Following cleaning, it is recommended that, where practical, the parts be handled only with clean cloth gloves, sealed in polyethylene bags, and welded as soon as possible.

2.2.1.1 Electron Beam Welding. Because of the sensitivity to interstitial contamination and recrystallization embrittlement, EB welding has received considerable attention for joining Mo alloys. Electron beam welding is performed in a consistently controlled high-vacuum chamber, so there is less opportunity for interstitial contamination. Welding in an inert atmosphere represents a considerably more complex monitoring problem. Electron beam welding also inputs significantly lower amounts of heat into the base metal, which minimizes thermal stress and grain growth. Fine control of the EB diameter and the focused high power allows much smaller heat-affected zones (HAZs) and weld metal as compared to GTA welding. Ammon and Buckman reported a DBTT of 180 K for GTA-welded Mo-50%Re as compared to 80 K for the base metal material.⁷ The difference in DBTT between the base metal and welded material was thought to be controlled predominately by the large grain size. Morito reported considerable bend properties at 77 K for EB welded Mo-50%Re.¹⁵ Typical EB welding conditions were as follows: Accelerating voltage = 50 kV, primary beam current = 50 mA, and welding speed = 30 mm/s. Kramer and Moore both reported successful EB welding of Mo-41%Re to Mo-44.5%Re for space-based power systems.^{3,16}

2.2.1.2 Welding Filler Metals. The need to use filler metals can be prompted by both geometrical and mechanical considerations. In the first case, increasing the base metal thickness or the distance between the pieces being welded may make filler metals necessary. In the second case, filler metals may be used to assist in filling surface porosity that may occur while welding PM materials or, more importantly, to improve the weldment ductility by permitting uniform distribution of stresses across the weld and HAZ. Examples of the latter are the use of Mo-Re filler alloys. The various Mo and Re combinations (e.g., Mo 10%–50% Re) may be used to take advantage of the strengthening and ductilizing effect of Re.

2.2.1.3 Preheating and Welding Heat Input. Molybdenum-based alloys are susceptible to cracking following welding because commercial alloys have very little as-recrystallized ductility. The thermal shock and residual stresses produced by welding can exaggerate this behavior. The specific welding preheat or interpass temperature to be used when welding an assembly is dependent upon both the size and shape of the assembly being welded, as well as the susceptibility to cracking of the particular alloy being welded. Joining objects with widely differing size can produce uneven heating and cooling, due to the ability of a larger object to dissipate heat more rapidly than a smaller object, producing stresses that may cause cracking. Preheating will result in a more uniform thermal gradient that will reduce the tendency toward cracking. Because of the very high thermal conductivity and melting temperature of Mo, preheating the weldment is almost an automatic activity. Preheat can be applied by moving the welding arc or beam over the surface prior to increasing the power to cause melting.

The energy density variations between different welding processes can affect the amount of preheating required. For example, the energy density of a GTA welding plasma is relatively low. This can result in more preheating prior to obtaining a molten zone than for an EB weld in the same material. The benefits of preheating to reduce thermal shock must, however, be balanced with the use of as low a heat input as possible to minimize the extent of recrystallization and grain growth in the HAZ. Preheating to high temperatures must be performed within a protective atmosphere to prevent contamination.

2.2.1.4 Stress Relieving. Molybdenum-based components are normally stress relieved after any processing operations that could contribute residual stresses. The appropriate stress-relief temperature and time for the various Mo-based alloys can be obtained from the manufacturer of the particular alloy. Typical stress-relief time and temperatures for Mo-Re materials are 1 hr at 900–925 °C (1,650–1,700 °F). Stress relieving should be performed in either a vacuum or a hydrogen furnace to prevent atmospheric contamination.

2.2.1.5 Gas Tungsten Arc Welding. To ensure optimum mechanical properties, it is imperative that the welding of Mo-based metals be performed in a purified inert atmosphere enclosure. Welding in air, using only the gas shielding from the welding torch, will result in severe contamination of the weld, with resultant reduced ductility. To minimize moisture permeation and outgassing from the chamber walls, a metal enclosure is superior to a plastic enclosure and is therefore recommended. Flexible polymer enclosures can be effective in combination with dynamic cleaning of the argon (Ar) shield gas. Calibrated gas analysis equipment is mandatory to monitor moisture and atmospheric elements that diffuse into the inert atmosphere. If a rigid metal enclosure is used, ideally, it should be capable of being evacuated to a pressure in the range of 10^{-3} to 10^{-6} mbar and have a helium (He) mass spectrometer leak rate of 1×10^{-8} atm cc/s, or better. It is recommended that the chamber be evacuated and backfilled, rather than simply purged with inert gas, to obtain the lowest residual atmospheric contamination. Dynamic gas purification, with equipment such as that available from the Vacuum Atmospheres Company, virtually eliminates the concern regarding atmospheric contamination of welds.

The use of plastics and elastomeric tubing in evacuated areas should be kept to a minimum. Stainless steel tubing should be used for all rigid plumbing. Viton[®] may be used for O-ring seals for joints needing frequent opening. Other joints should be sealed with metal wire gaskets. Viton or Teflon[®] should be used for the electrical insulation wiring inside the chamber. Where flexible water lines are required, an elastomer having low outgassing and moisture permeability, such as butyl rubber, is recommended. All valving should be suitable for vacuum exposure and bellows-sealed valves are preferable. Tubing connections to valving or chamber ports may be made using swage-type fittings, although welded or silver soldered (not soft-soldered) fittings with copper (Cu) or nickel (Ni) gaskets are best. Port gloves should be made from sulfur-free butyl rubber to control moisture permeation. The protective welding gloves, to cover the port gloves during manual welding, should be made from aluminized fiberglass rather than using the typical leather welding gloves. Heat may be applied to the chamber by using heating tapes or infrared lamps to facilitate the elimination of adsorbed moisture from the walls of a rigid chamber during evacuation. A bake-out temperature of 40–75 °C (100–170 °F) is adequate to reduce the residual moisture in the chamber to <1 ppm (dewpoint –80 °C (–112 °F)) in a vacuum of 10^{-4} mbar or better. All surfaces exposed to the vacuum should be degreased and kept clean and dry to reduce contamination and pumping time. After filling the chamber with the shielding gas, monitoring the chamber atmosphere for oxygen, nitrogen, and moisture is recommended. Oxygen and moisture levels of <10 ppm can be obtained from a system such as previously described. Dynamic gas cleanup can ensure many hours of productive welding, especially if parts are transferred via an evacuable antechamber. Welds produced in this atmosphere will be shiny with no coloration.

GTA welding of refractory metals is performed using direct current with the electrode negative (DCSP). Thoriated tungsten electrodes are used. Grinding the electrode to a sharp point facilitates arc placement and manipulation. Down slope of the welding current will eliminate crater cracking. The high

melting point and thermal conductivity of Mo-based metals necessitates the use of slightly more energy than would be used for metals having a lower melting temperature. The electrode diameter is determined on the basis of the current required. Because welding is being performed in an inert atmosphere, no additional torch shielding is required. The welding torch may be either water cooled or uncooled. Water cooling permits using higher currents, but introduces possible moisture contamination due to permeation through the walls of the elastomeric tubing. Custom-modified GTA torches with long SS bellows for water lines are recommended. An uncooled torch with a ceramic handle can be fabricated for very critical small-scale welding. This design minimizes possible sources of contamination.

Automatic orbital GTA welding is recommended for tubing. Weld heads made by the Arc Machines Company were proven to be reliable in the SP-100 Program. Clamping fixtures within the heads must be custom made from refractory metal instead of the standard SS clamps. The same holds true for the welding fixtures used to hold the pieces during EB welding, where they should be either water cooled or faced with a material that will not melt and bond to or contaminate the weldment. Molybdenum or tungsten inserts are recommended.

2.2.2 General Forming

Mo-Re alloys can be formed by common metal working processes such as conventional single-point turning, threading, electric discharge machining (EDM), drawing, bending, spinning, and punching. Figure 9 shows images of Mo-41%Re components that were machined for an alkali metal thermal-to-electric (AMTEC) mockup cell.¹⁶ The components were produced accurately on the first attempt. Single-point turning and EDM processes work well for Mo alloys. EDM is employed for intricate Mo shapes with stock removal rates up to 0.5 in³/min and ± 0.0005 -in tolerances. Grinding should be considered primarily for finishing and not for major stock removal. Grinding can be handled on conventional machines with standard feeds and speeds. Forming Mo alloys is commonly used to make components, but careful attention should be given to the effect on mechanical properties. Thin sections can be bent at RT without cracking. Preheating may be necessary for complex or thicker sections. In general, specific metalworking details are available from the producers of the material.



Figure 9. Mo-41%Re parts machined from arc-cast material for AMTEC system.

2.2.3 Fabrication Vendors

A vendor that has the relevant experience and capability for refractory metal manufacturing should complete fabrication and assembly of liquid-metal circuit components. For example, a company such as Advanced Methods and Materials (AMM) is currently fabricating Mo-Re heat pipes for lifetime testing at MSFC (AMM also has direct experience with the planning and fabrication of two refractory metal loops for SP-100). Table 4 shows an estimated ROM cost and availability for fabricating the baseline refractory circuit. The fabrication is separated into the following phases:

- Materials.
- Equipment.
- Planning/development.
- Component fabrication.
- Circuit assembly.

Table 4. Cost and time estimates for an Mo-47.5%Re circuit.

Description	Cost (k)	Delivery (mo)
Basic Mo-Re materials (options)		
PM shapes (tubes, rod, sheet)	\$1,500	9
Arc-cast shapes	\$1,800	12
Fabrication equipment/hardware	\$1,750	12
– Welding monitoring (chambers/portable/NDE)		
– Heat treat furnaces (vacuum/hydrogen)		
Fabrication design/development	\$2,000	12
– Fabrication processes/procedures		
– Experimental material evaluations		
Component fabrication (core/HX/tanks)	\$1,000	12
Circuit major component assembly	\$1,000	9
Integration design/development	\$750	9
– Layout/geometry/interfaces in test chamber		
– Ancillary systems (heaters, pump, ins., etc.)		
Test chamber integration/ancillary system fabrication	\$1,000	12
– Develop procedures and facility modifications		
– Acquire and fabricate (pump, supports, etc.)		
Total (assuming PM material)	\$9,000	30

The first step is to break the system down into components and determine how each will be fabricated and assembled to form the circuit. This is best accomplished with a computer-aided design (CAD) layout. The design should allow a large bulk of the system to be EB welded to minimize contamination. The CAD layout will be crucial in determining weld access and fabrication procedures. At some point, the assembled components will reach a size that requires a very large vacuum chamber for EB welding

or an inert enclosure for orbital GTA welding to complete the fabrication. The setup of a large vacuum chamber to support EB welding is a very expensive and time-consuming proposition. The more cost-effective approach is to organize the assembly process so that a minimum number of GTA welds are required for final integration at the test site. Given the susceptibility of Mo-Re to oxygen pickup, a trailing shield and inert gas purge would not be adequate. Thus, portable chambers, hard shell or inflatable, would be necessary. Many of the fabrication procedures can be determined with the CAD layout aided by welding/joining lab experiments. Table 4 provides an initial estimate (both cost and time) to field a Mo-47.5%Re PM refractory metal system ready for testing but not tested. The total cost is estimated at \$9,000k with a period of performance of ≈ 30 mo. A proposed simplified schedule for key operations is shown in table 5.

Table 5. Estimated fabrication schedule for an Mo-47.5%Re circuit.

	Quarters										
	1	2	3	4	5	6	7	8	9	10	11
Mo-Re materials	X	-	-	X							
Fabrication equipment/hardware		X	-	-	X						
Fabrication design/development process		X	-	-	X						
Component fabrication				X	-	-	X				
Circuit assembly of major components						X	-	X			
Integration design/development					X	-	X				
Fabrication of integration hardware							X	-	X		
Integration into test chamber								X	-	X	

Fabrication of a refractory metal flow circuit will not only provide a system for evaluating components, but will also serve to develop refractory metal fabrication/testing experience. A key aspect of the effort will be to successfully develop fabrication and NDE procedures. As mentioned previously, most of the welds should be produced using fully automatic, computer-controlled, EB or orbital, auto-genous GTA welding within an evacuable controlled atmosphere chamber. In selected locations, the use of automatic equipment may not be practical. Welding parameters should be developed and confirmed using the appropriate destructive (metallography, tensile, chemical, etc.) and NDE correlation. Components should be inspected prior to initial processing as raw plate, after forming or machining to make a component, and after being welded to make the final assembly. Typical NDE inspection techniques are He mass spectrometer leak detection, fluorescent dye penetrant, and ultrasonic or radiographic testing. Procedures should also be developed for cleaning components before processing using multiple steps including solvent and detergent cleaning followed by pickling and acid cleaning. Details on these and other fabrication procedures are given in the SP-100 flow loop report by Bryhan.¹

3. FLOW CIRCUIT ESTIMATES FOR TANTALUM ALLOY SELECTION

Material estimates are based on the procurement of raw stock and the additional processing/fabrication needed to manufacture components and assemble the liquid-metal flow circuit. The main United States (U.S.) supplier for Ta alloys is the Wah Chang Co., Albany, OR. However, sales have involved mostly pure Ta or the Ta-10W alloy. Since most of the development for T-111 and ASTAR-811C was done on previous Space Power Programs of the 1960s-1970s, it will be necessary to qualify the production procedures to provide similar mechanical and chemical performance. PMTI can also provide Ta alloys and is currently producing both T-111 and ASTAR-811C products. PMTI was formerly the division of Westinghouse Electric Corporation that was responsible for the development of T-111 and ASTAR-811C.

According to the U.S. Geological Survey database, there has been no Ta mining in the United States since 1959. The United States imports Ta, with $\approx 57\%$ coming from Australia. In contrast, the United States exports Mo. In 2004 the Government Defense National Stockpile Center sold ≈ 11 tons of Ta metal ingots and had 9 tons in uncommitted inventory <<http://minerals.usgs.gov/minerals/pubs/commodity/niobium/tantamcs05.pdf>>.

Creating a Li flow circuit made from the candidate Ta alloys will require similar infrastructure to that of an Mo alloy flow circuit. However, Ta alloys have some practical advantages. First, Ta has inherently more RT malleability as well as useful ductility following welding. Second, previous space reactor programs developed many complex items from T-111 and ASTAR-811C. The knowledge gained from these programs can be applied to this new Li flow circuit. In contrast, Mo-based alloy composition and processing methods remain to be optimized to allow building large structures.

3.1 Material Considerations

Tantalum alloys are attractive for space nuclear power systems because they have appropriate elevated temperature mechanical properties, they have sufficient RT malleability, are ductile following welding, are somewhat commercially available (compared to Mo-Re alloys), and they have resistance to pertinent heat-transfer liquids and gases (as long as interstitial impurities are kept to low concentrations). The Oak Ridge National Laboratory (ORNL)/Department of Energy (DOE) publication, "Refractory Alloy Technology for Space Nuclear Power Applications," provides substantial background information pertinent to the design of the proposed flow circuit.¹⁷ This DOE report summarizes the knowledge gained over many years by experts in refractory metals. Included is information concerning melting/production, compatibility with liquid metals, machining, fabrication, welding, mechanical properties, and irradiation exposure. As previously mentioned, the main concern for Ta alloys is embrittlement by oxygen and hydrogen.

3.1.1 Alloy Selection and Processing

T-111 was developed in the 1960s as an alloy combining compatibility with liquid alkali metals, strength, creep resistance, fabricability, and weldability. ASTAR-811C was developed to increase the temperature of operation while maintaining favorable fabricability and corrosion resistance. These alloys are produced by a series of melting and purification steps using EB and arc-melting processes. As with wrought Mo, these alloys are then mechanically worked to refine the grain structure by extruding, rolling, or forging.¹⁸ Nominal compositions for T-111 and ASTAR-811C are given in table 6.

Table 6. Chemical analysis of T-111 and ASTAR-811C.

Alloy	Weight (%)			Weight (ppm)							
	W	Hf	Re	C	O	N	Ni	Co	Fe	Cu	Si
T-111	8	2	–	<50	<70	<30	NR	NR	NR	NR	NR
ASTAR-811C	8	0.7	1	250	<25	<30	NR	NR	NR	NR	NR
GE specification, 1964, T-111	8	2	–	50	100	50	50	50	50	NR	NR
Commercial T-111 heats, 1960–1970, 13 heats	8	2	–	22 ±17	38 ±16	18 ±5	<60	<60	<60	20	<60

NR=data not reported

There will be major challenges for any refractory metal for space nuclear power because much of the infrastructure to produce these alloys must be reestablished. Buckman summarizes key cautions as follows:¹⁸

- No single company is integrated from melting to secondary fabrication. This means that companies that produce items from other metals may be included in this program. The production of Ta alloy ingots and components will require development of stringent process controls and material specifications.
- Refractory alloys, particularly those containing Zr or Hf are extremely sensitive to contamination by Fe, Cu, Ni, and cobalt (Co). Control must therefore be exercised to ensure that this does not occur. For example, ingots must be melted into molds that have only been used for refractory metals and not, for example, steel or Ni alloys.
- Annealing furnaces must be dedicated to processing only refractory metals. Trace amounts of low-melting contaminate will destroy the properties necessary for a space reactor, and waste time and money during the testing phase of this program. Particular attention must be given to ingots and billets before working or heat treatment so that, for example, steel from tooling or glass lubricants is not inadvertently incorporated into the metal.
- Specifications must be developed that address materials and process controls. Two ASTM specifications exist: (1) ASTM B708-01 which covers Ta alloy plate, sheet, and strip and (2) ASTM B521-98 (2004) which covers Ta seamless and welded tubes. These specifications will not be sufficient for the concerns of this reactor program. Of more pertinence would be the GE specification by D.W. Miketta and R.G. Frank, SPPS-22-R1, Ta Alloy T-111, December 23, 1964, NASA Contract 2547.

3.1.2 Material Property Summary

The mechanical properties and liquid metal behavior of T-111 and ASTAR-811C were fairly well documented for the materials produced at the time of past testing. The 1984 ORNL document includes many pertinent results, but only creep properties are reported here for comparison. A major goal for this flow circuit will be to evaluate currently produced materials so as to reestablish historical performance. The primary strength property for space nuclear reactor materials is resistance to creep deformation. Unlike Mo-Re alloys, creep properties of Ta alloys have been studied on numerous programs and long-term creep data are readily available for T-111 and ASTAR-811C. Figure 8 shows the density compensated stress for 1% creep strain in 61,000 hr as a function of temperature for various refractory alloys.⁸ As shown, Ta alloys have better high-temperature creep strength than the other alloys of interest, with ASTAR-811C being superior to T-111.

3.1.3 Raw Material Cost and Availability

Tantalum alloy mill products in the form of tubing, plate, and solid round bar stock are required to fabricate the liquid-metal circuit components. These products can be fabricated by rolling, extrusion, swaging, and drawing. Table 7 lists the approximate bulk dimensions and quantities required to fabricate the concept loop.

Table 7. Bulk materials summary for flow circuit.

Stock	Dimensions	Quantity		Components
		(in)	(ft)	
Plate	16 in wide x 0.125 in thick	137	12	5-in OD pipe sections up to 42 in long
Plate	10 in wide x 0.125 in thick	60	5	3-in OD pipe sections up to 27 in long
Plate	1 in thick x 8 in x 8 in	6 pieces		Miscellaneous flanges, plates
Plate	4 in wide x 0.125 in thick	192	16	Formed and machined support structures
Seamless tube	1-in OD x 0.095-in wall	456	38	Miscellaneous piping
Seamless tube	0.5-in OD x 0.035-in wall	1,200	100	Includes 37 26-in-long tubes
Seamless tube	5/16-in OD x 0.035-in wall	2,784	232	Includes 107 26-in-long tubes
Seamless tube	3/16-in OD x 0.035-in wall	36	3	Miscellaneous piping
Round bar stock	1-in OD	36	3	Miscellaneous bosses, pipes, fixtures, etc.
Round bar stock	1.25-in OD	48	4	Miscellaneous bosses, pipes, fixtures, etc.
Round bar stock	5/64-in OD	60	5	Miscellaneous bosses, pipes, fixtures, etc.

Table 8 lists potential suppliers of Ta alloys. Wah Chang is the only major supplier that has consistently produced large quantities of Ta alloy. For the ongoing Trident Nuclear Missile Program, Wah Chang recently produced several thousand pounds of Ta-10W; however, no T-111 or ASTAR-811C has been produced in several decades. Wah Chang has four EB melting furnaces as well as vacuum-arc melting equipment. PMTI is currently producing Ta alloy ingots for research and development activities. PMTI has the capability to produce small 50-lb ingots as well as small rod and plate materials. Larger plate and tubing fabrication would have to be subcontracted to other metalworking vendors. Also, there

Table 8. Tantalum material vendors capability.

Vendor/Material	Capability
Wah Chang Albany, OR 541-967-6977 PMTI	Ta supplier and fabricator Small ingots (max. 80 in ³) can produce small rod and plate materials; larger plate and tubing would be subcontracted to vendors
Cabot Boyertown, PA 800-531-3676	Ta supplier and fabricator
H. C. Starck 201-438-9000	Ta supplier and fabricator

was some indication that the costs for T-111 would be less than ASTAR-811C but no details were provided to quantify the difference. The higher cost material (ASTAR-811C) was used for this ROM estimation. Two other potential vendors were also identified; however, they provided no information for the fabrication of T-111 or ASTAR-811C materials.

3.2 Fabrication Considerations

General issues associated with fabricating refractory metal components for containing molten Li involve controlling contamination that might be captured within the metal during deformation, machining, and heat treating. Welding will likely be performed by GTA and EB processes. Assembly of the bulk components and attachment to piping, flanges, and support structures should be performed using EB welding wherever practical to maximize purity and minimize heat effects. Final assembly of the components and piping will be accomplished using GTA, due to the overall physical size of the layout. Environmental and process controls will be established and analysis instruments implemented to record/monitor the variables known to influence the structural properties of the final product. These variables include interstitial elements within inert cover gas or vacuum welding and heat-treating systems, chemical cleaning/pickling processes, and the applied strains during mechanical forming.

3.2.1 Welding

Welding considerations for Ta alloys are the same as for Mo alloys regarding interstitial contamination. Specific information for T-111 and ASTAR-811C is contained in the 1984 ORNL document, previously mentioned, authored by G.G. Lessmann. To provide an appreciation of challenges for welding these alloys, the metallurgy and alloying philosophy are described and inert atmosphere and vacuum control and monitoring are emphasized.

It is important to note that while many large weldments were produced from T-111 in the GE program of the 1970s, attention must be paid to observations of weldment under bead cracking due to Hf. Lessmann reported weldment cracking in multipass welds in direct proportion to Hf concentration (fig. 10).¹⁹ The vareststraint test applies a controlled variable bending, or augmented strain, to a test weldment. Sample welds are then examined by microscope and the amount of cracking is measured versus the percent strain. ASTAR-811C (1% Hf) was shown to be less susceptible than T-111 (2% Hf).

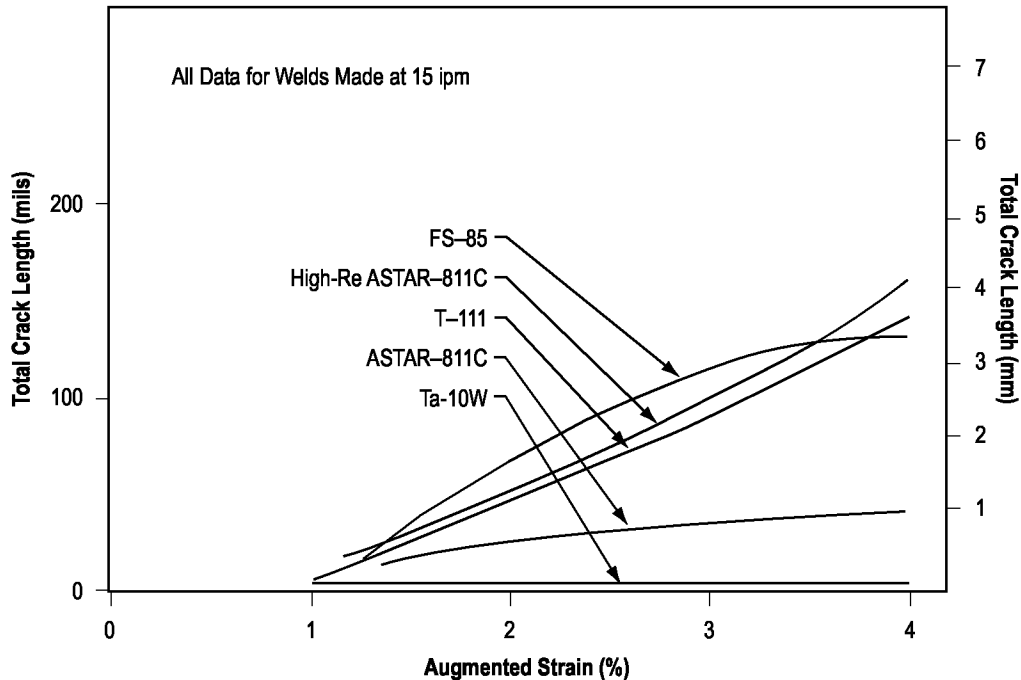

Figure 10. Vareststraint test results rank cracking sensitivity exactly as observed in plate welding.

FS-85, an Nb-based alloy containing Zr instead of Hf, was also part of the previous testing. Lessmann concludes that the lower melting temperature Hf is concentrated along grain boundaries. Cracking is due to weldment solidification stresses.²⁰ These observations illustrate that while many T-111 prototype reactor components were built, these Ta alloys were only beginning to be investigated to determine their full metallurgical characteristics. A goal of the current program must be to more fully understand the key metallurgical variables for these refractory metals. Lessmann summarizes information needed for welding Ta alloys, including understanding of multipass welding and weld repairs, NDE, in-process controls, and bimetal transition joints.

3.2.2 General Forming

Tantalum alloys T-111 and ASTAR-811C have been produced commercially in all forms including tubing, plate, and sheet. W.R. Young provides a detailed overview of component fabrication for T-111.²¹ Many complex parts were successfully created. Again, a goal for this program is to produce T-111 or ASTAR-811C of quality sufficient to duplicate past accomplishments.

3.2.3 Fabrication Vendors

Fabrication and assembly of the liquid-metal circuit components should be completed by a vendor that has relevant experience and capability for refractory metal manufacturing. Metal Technology, Inc., formerly known as B J Enterprises, located in Albany, OR, produced virtually all of the Nb-1Zr components for the SP-100 Li loops. Metal Technology, Inc. has extensive drawing, bending, forming,

and forging expertise with refractory metals <www.b-jenterprises.com>. Special Metals, Inc., located in Conroe, TX, has been a fabricator of Ta structures for the chemical and pharmaceutical industries since 1985 and should be contacted as a candidate vendor <www.Tafabricators.com>. Table 9 shows a general estimated ROM cost and availability for fabricating the baseline refractory circuit. The fabrication is separated into the following phases:

- Materials.
- Equipment.
- Planning/development.
- Component fabrication.
- Circuit assembly.

Table 9. Cost and time estimates for a Ta alloy circuit.

Description	Cost (k)	Delivery (mo)
Basic material shapes (tubes, rod, sheet)	\$3,000	16
Fabrication equipment/hardware	\$1,750	12
– Welding monitoring (chambers/portable/NDE)		
– Heat treat furnaces (vacuum/hydrogen)		
Fabrication design/development	\$3,000	12
– Fabrication processes/procedures		
– Experimental material evaluations		
Component fabrication (core/HX/tanks)	\$1,500	12
Circuit major component assembly	\$1,000	12
Integration design/development	\$750	9
– Layout/geometry/interfaces in test chamber		
– Ancillary systems (heaters, pump, ins., etc.)		
Test chamber integration/ancillary system fabrication	\$1,000	12
– Develop procedures and facility modifications		
– Acquire and fabricate (pump, supports, etc.)		
Total	\$12,000	36

The first step is to break down the system into components and determine how each will be fabricated and assembled to form the circuit. The design should allow a large bulk of the system to be EB welded to minimize contamination. A detailed CAD layout should be generated, providing crucial interference and alignment data for weld access and fabrication procedures. At some point, the assembled components will reach a size that requires a very large vacuum chamber for EB welding or an inert enclosure for orbital GTA welding to complete the fabrication. The setup of a large vacuum chamber to support EB welding is a very expensive and time-consuming proposition. The more cost-effective approach is to organize the assembly process so that a minimum number of GTA welds are required for final integration at the test site. Given the susceptibility of Ta alloys to oxygen pickup, a trailing shield

and inert gas purge would not be adequate; thus, portable chambers, hard shell or inflatable, would be necessary. Much of the fabrication procedure can be determined with the CAD layout aided by welding/joining lab experiments. Table 9 provides an initial estimate, both cost and time, to field a Ta alloy refractory metal system ready for testing but not tested. The total cost is estimated to be ≈\$12,000k with a period of performance of ≈36 mo. A proposed simplified schedule for key operations is shown in table 10.

Table 10. Estimated fabrication schedule for a Ta alloy circuit.

	Quarters											
	1	2	3	4	5	6	7	8	9	10	11	12
Materials (T-111, ATAR-811C)	X	-	-	-	-	X						
Fabrication equipment/hardware			X	-	-	X						
Fabrication design/develop process				X	-	-	X					
Component fabrication					X	-	-	X				
Circuit assemble major comp.							X	-	X			
Integration design/develop						X	-	X				
Fabrication of integration hardware								X	-	X		
Integration into test chamber									X	-	-	X

Fabrication of a refractory metal flow circuit will not only provide a system for evaluating components, but will also serve to develop refractory metal fabrication/testing experience. A key aspect of the effort will be to successfully develop fabrication and NDE procedures. As mentioned previously, most of the welds should be produced using fully automatic, computer-controlled, EB or orbital, autogenous GTA welding within an evacuable or controlled atmosphere chamber. In selected locations, the use of automatic equipment may not be practical. Welding parameters should be developed and confirmed using the appropriate destructive (metallography, tensile, chemical, etc.) and NDE. Components should be inspected prior to initial processing as raw plate, after forming or machining to make a component, and after being welded to make the final assembly. Typical NDE inspection techniques are He mass spectrometer leak detection, fluorescent dye penetrant, and ultrasonic or radiographic (three-dimensional x-ray tomography) testing. Procedures should also be verified for cleaning components before processing, using multiple steps including solvent and detergent cleaning followed by pickling and acid cleaning. Details on these and other fabrication procedures are given in the SP-100 flow loop report by Bryhan.¹

4. LIQUID-METAL PUMP

Alkali liquid-metal pumps have been designed, built, operated, and used extensively for many different high-temperature applications for more than 50 years. During that period, many liquid-metal nuclear reactors for terrestrial power production and demonstration were built and operated by the United States, England, France, Italy, Germany, Russia, Japan, and perhaps others. Each liquid-metal reactor system required a liquid-metal primary, secondary, and most often auxiliary pump system for plant operation.

Four basic types of alkali liquid-metal pumps were built during this period and several have dominated the use since then: (1) Electromagnetic (EM) conduction pumps (2) EM induction pumps, (3) mechanical induction pumps, and (4) mechanical centrifugal pumps. Only EM-type pumps are considered in this TM for proposed laboratory and space nuclear power system applications.

4.1 Electromagnetic Conduction Pumps

Two types of EM conduction pumps have been designed, built, tested, and used: (1) Direct current (DC) and (2) alternating current (AC). Generally, conduction pumps were used for low pressure/flow applications. They required low voltages and high currents through the pump throats and were simple to operate; however, they have a low overall efficiency of typically <5%.

Most DC conduction pump applications were on small-diameter test circuits and low-power space power systems such as the United States SNAP 10A and Russian RORSATS, TOPAZ I, and TOPAZ II. More than 100 were built for space power system development and flight applications. Note that multiple thermoelectric powered DC conduction pumps were designed for the SP-100 system to pump primary and secondary Li metals, but the program was cancelled before the EM pumps were demonstrated/qualified for use.

For higher pressures/flow test circuit applications (<500 gpm), many single-phase AC conduction pumps were built and operated because of their design flexibility. They also required high current with in-phase electrical and magnetic fields to pump the liquid metals.

4.2 Electromagnetic Induction Pumps

There are four types of applicable EM induction pumps: (1) Flat linear induction pumps (FLIPs), (2) annular linear induction pumps (ALIPs), (3) helical induction pumps (HIPs) and, (4) centrifugal induction pumps (CIPs). The FLIP, ALIP, HIP, and CIP require three-phase electrical windings (like a three-phase electric motor) and can be operated using variable frequencies above or below 60 Hz.

Both HIP- and CIP-type EM pumps have high flow limitations and are not considered practical for the refractory metal flow circuit concept applications at this time. The remaining liquid-metal EM

pump options that support current and future applications at this time include AC conduction, AC flat linear induction, and AC annular linear induction.

4.3 Pump Selection

Several possible avenues can be pursued in procuring a liquid-metal pump for the refractory metal circuit. The EM pump used in the SLiC design is a commercial Creative Engineers, Inc. (CEI) style 6–AC conduction pump. While this pump type may not be the most advantageous choice, due to nonprototypic design/operation, it is the initial frame of reference from which to base a ROM estimate. The following three possible options are listed, each carrying a range of cost, availability, and potential for evolution to a prototypic flight design:

(1) Utilize off-the-shelf technology with specific design modifications to accommodate both refractory metal material and high-temperature operation. This option is the cheapest with the fastest potential delivery; however, the only current option is an AC conduction style unit with low efficiency and minimal evolvability to a flight design. This pump would serve as a good baseline, providing a facility capability to test flow, components, etc. Modifications to this pump include a Mo-Re refractory metal flow channel with Mo bussbars attached to the flow channel by EB welding. Cooling is required only for the magnet and transformer winding (to absorb the internal resistive heating) and can be provided by either a containment vessel with purge (as used with the SLiC) or by equipping the windings with coolant loops to locally intercept heat. The expected overall pump efficiency is estimated to be at par with a style VI model, $\approx 3\%$ to 5% range. (Some improvement could be possible but would require additional engineering cost.) This approach represents the lowest cost and shortest schedule option.

(2) Capitalize on a past NASA liquid-metal pump contract, managed by Glenn Research Center, that focused on the design and fabrication of a ground-test demonstrator pump. During phase I (6 mo) the contractors, General Atomics and Lockheed Martin, performed trade studies examining various pump types followed by a more detailed design of an ALIP after project downselect. The 24-mo phase II downselect to a single contractor for a turnkey ALIP pump based on phase I results and final NASA design criteria (specific flow, pressure, temperature, and fluid conditions) was canceled. The envisioned final design selection would be suitable for Li flow at temperatures up to 1,250 K and could potentially meet the operating parameters for the Li-flow circuit. This development approach is expected to be significantly long and more expensive when compared to a commercial unit; however it provides a more flightlike hardware component.

(3) Issue a solicitation with specific detailed pump requirements that match the flow circuit design space such as the type, power, geometry, flow rate, temperature, fluid type, and pressure rise. This would result in a product that is more ideally suited to the desired application; however, it would have a bigger impact to both cost and schedule when compared to the option 2 effort, since the design/study phase may need to be reexamined.

The commercial pump unit was selected as a baseline for this ROM estimate. This approach appears to be the most reasonable, since the actual flow circuit geometry is not of a prototypic nature.

5. INSTRUMENTATION CONSIDERATIONS

The sensors, signal conditioning, and data acquisition systems investigated for current and future refractory metal flow circuit applications must be selected to ensure both accuracy and resolution of measured data. Some of the key design parameters include anticipated ranges for temperatures, pressures, fluid flows, liquid levels, stresses/deformations, power levels, working fluid purity levels, reliability, etc. In addition, the material compatibility of the sensors must be considered to determine potential life-limiting issues (resulting from contamination) or the possibility of sensor failure due to temperature or pressure extremes. The consideration of these factors must occur before approval of final designs and hardware procurement to establish confidence in anticipated flow circuit operations and performance assessments.

5.1 Temperature Measurement

Thermocouple (TC) temperature sensors can be fabricated using various materials to satisfy the required temperature range of operation, sensitivity, and calibrated accuracy. The TC hot junction can be produced by inert gas fusion welding, spot welding of the lead wires together, or by separate spot welding or mechanical/electrical connection of the lead wires to the temperature source. In addition, an intermediate material is often required to successfully bond a TC to a refractory metal component. For example, nickel foil is typically used to bond C and K type TCs to Mo and Mo-Re alloys. The metallurgical properties of the temperature source and compatibility with the metallurgical properties of the selected TC type, or intermediate bonding material, must be considered. Diffusion of the different materials at the interface can become the source of sensitivity and accuracy shifts and/or fractures and failures of the fluid circuit. This becomes an increasing concern as test duration and temperatures are increased.

Depending on the environmental requirements of the application, the lead wires can be insulated using ceramic beads, fiberglass fabric, or swaged insulated tubing with the TC junction either internally grounded or ungrounded to the tubing. The outgassing of materials used for electrical insulation of TCs, i.e., fiberglass binders, can contaminate the high-temperature refractory metal component or other ceramic insulators used in the components/subsystems.

An alternative to contact-style TC temperature measurement devices is the two-band optical pyrometer. These units can cover a wide temperature range and can be calibrated with a known temperature (local TC); however, they require direct line-of-sight access to the measurement location. In addition, they must be mounted fairly close, depending on sighting optics, which can be problematic in a vacuum environment. These units are also expensive, ranging from \$3,500 to \$4,500 per unit.

5.2 Pressure Measurement

Typical pressure measurement units require a flexible, thin-metal diaphragm interface between the working fluid and the actual pressure sensor or transducer. This can prove to be an issue when

considering the use of these units in a liquid-metal flow circuit, requiring the user to address a host of design details such as metallurgical compatibility, operating temperature, and long-term reliability. Issues that affect accuracy, sensitivity, and reliability include the following:

- The diaphragm must be metallurgically compatible with all wetted and contact interfaces involved; i.e., the alkali liquid metal, the pressure instrument structure, any intermediated fluid or mechanical pressure-transfer material, and possibly the actual sensor (strain gauge, displacement sensor, etc.).
- Operational challenges at the liquid metal and diaphragm interface include:
 - Accumulation of outgassing at the sensor.
 - Wetting the sensor diaphragm by the liquid metal.
 - Cold trapping impurities at the diaphragm, resulting in isolation of the pressure transducer from the alkali liquid-metal circuit.
 - Servicing the unit including draining of the liquid metal from the diaphragm.
 - Temperature sensitivity of the diaphragm, transducer mechanism, and sensor.
 - Interaction between the alkali metal and any intermediate transducer fluids used within the instrument.

Note that strain gauges applied directly to the external surfaces of the piping or diaphragm can be used as pressure sensors, if properly calibrated; however, they must be compatible with the material and capable of operation at the maximum temperature—not a trivial endeavor.

5.3 Flow Measurement

There are several types of fluid flow measurement techniques that can be implemented in a liquid-metal flow circuit, two of which include EM meters and orifice-style meters. The basic magnetic-type flowmeter is illustrated in figure 11.²² The operation of this unit is similar to a DC conduction pump, operating in reverse; however, in this case, the fluid flow through the magnetic field produces a voltage that can be measured and correlated to produce a flow versus voltage curve. The magnetizing field can be provided by permanent magnets or by controlled DC EM coils. Magnetic materials must be carefully selected (high Curie point) to ensure long-term sensitivity and accuracy at the high operating temperature of the circuit. Permanent magnetic flowmeters can also result in cold trapping at the flowmeter duct during initial flow circuit startup (acts as a thermal sink). Wetting of the flowmeter duct is required to obtain reliable fluid flow data. Note that both the permanent magnet and EM flowmeters require calibration to obtain reliable flowmeter data.

The orifice flowmeter is illustrated in figure 12. This unit requires that a differential pressure be measured across an orifice located within the liquid-metal flow stream. Accuracy of this method is highly dependent on the orifice design to produce a measurable pressure drop with minimal flow impact. The orifice must also be calibrated to obtain an accurate flow coefficient. The final configuration requires the use of two pressure sensors, alkali-metal compatible, that can be used to generate an accurate and repeatable differential pressure measurement. There are many challenges faced in setting up, maintaining, and operating this type of flow sensing technique.

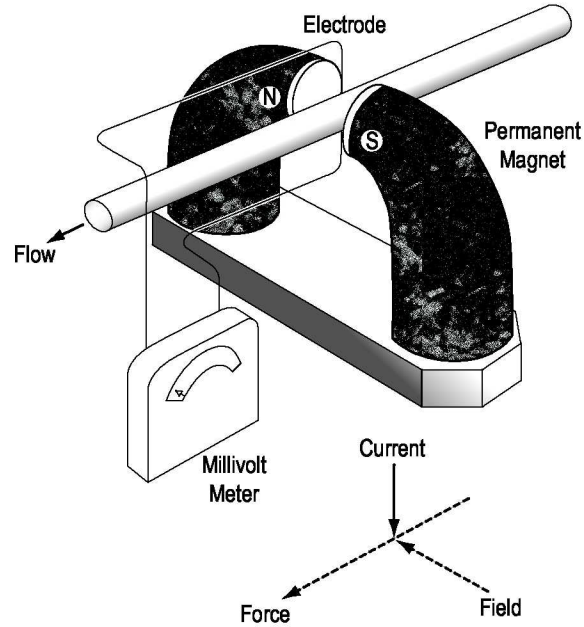

Figure 11. EM-style flowmeter.

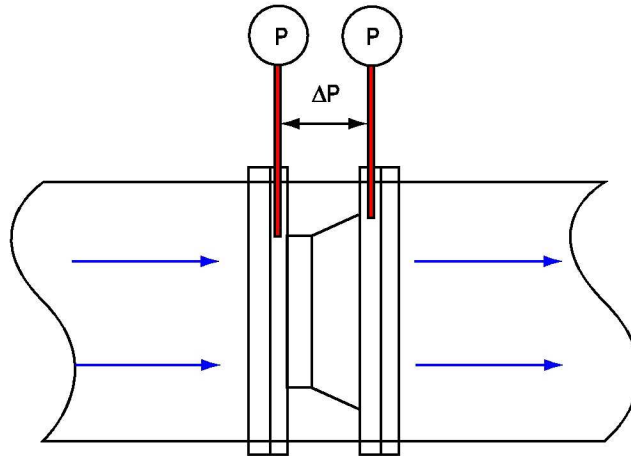

Figure 12. Orifice plate-style flowmeter.

In a condition where no flow measurement device is installed in the liquid-metal circuit, a simplistic estimate of the mass flow rate can be made based on the heat exchanger power balance. Specifically, the power transferred by the heat exchanger to the cooling flow is proportional to the flow rate and temperature drop. By assessing the power absorbed by the coolant flow (Q_{fluid}), the primary alkali-metal flow rate can be determined. The power transferred to the coolant flow is calculated using the measured coolant flow rate and coolant temperature increase given by,

$$Q_{fluid} = \dot{m}_{coolant} C_p (T_{out} - T_{in}) , \quad (1)$$

where T_{in} and T_{out} are the coolant inlet and outlet temperatures of the coolant flow, C_p is the specific heat of the coolant, and $\dot{m}_{coolant}$ is the mass flow rate. Assuming minimal environmental losses at the steady state condition, the primary alkali-metal cooling flow (\dot{m}_{alkali}) can be related to the coolant flow power and temperature drop in the alkali-metal flow stream as follows:

$$\dot{m}_{alkali} = \frac{Q_{fluid}}{C_{p-alkali} (T_{out-alkali} - T_{in-alkali})} , \quad (2)$$

where $T_{in-alkali}$ and $T_{out-alkali}$ are the inlet and outlet temperatures of the alkali metal flow and $C_{p-alkali}$ is the specific heat of the alkali metal.

Obviously, the accuracy of this method is strongly affected by the assessment of the heat transfer, which is influenced by a number of parameters such as thermal losses, transients, and the ability to accurately assess fluid properties as a function of temperature. In addition, the accuracy of this technique is limited to approximate steady state operations, due to the thermal mass of the heat exchanger that limits its transient response performance.

In general, for application to most liquid-metal flow circuits, a simple permanent magnetic flow-meter is the easiest to design, fabricate, and implement; it also has high reliability with no moving parts. The flow versus output voltage can be calculated prior to installation in the flow circuit and then checked using the heat exchanger power balance. Precise pretest calibration would require installation in a liquid-metal circuit, capable of operating at suitable flow and temperature, that is certified and has traceable records to approved standards. In addition to primary flow measurement, a smaller liquid-metal flow-meter may be required if a sampling branch with plugging valve is incorporated in the primary circuit to determine oxide concentrations by precipitation.

6. GENERAL ASSEMBLY, INTEGRATION, AND OPERATION

While there are a multitude of concerns and issues that are associated with the assembly, integration, and operation of a refractory metal circuit, some of the major issues are identified in sections 6.1–6.3 for edification of the reader.

6.1 Operational Environment

The flow circuit will be operated within a SS vacuum chamber built for ultrahigh vacuum (UHV) service. All fittings and penetrations will have a He leak rate of 10^{-9} cc/s or less and gasket materials will be consistent with possible exposure to Li vapor and condensate. The experiences gained during the operation of the SP-100 Li loops will establish the operating procedures for this chamber system. Calibrated residual gas analysis equipment and vacuum gauges will monitor the chamber vacuum. Automatic alarms for pressure rise and target molecular weight species will monitor, record, and interface with safety systems.

The chamber will be evacuated using mechanical roughing pumps having cold traps to prevent back streaming. UHV conditions will be achieved and maintained by triple cryopumps. Two pumps will always be in operation, allowing the third pump to run through its periodic regeneration cycle. Circuit heatup will be controlled so that residual species within the chamber atmosphere can be evacuated before the refractory metal components reach key metallurgical temperature points. Multilayer foil insulation will further protect the circuit refractory metal components from offgassed species. Nb-1%Zr foil is recommended due to its relative low cost and malleability following recrystallization.

The circuit structure will be supported to ensure freedom from distortion and to accommodate thermally induced movement. The supports will minimize thermal shunting from the circuit and thermal soak back into the chamber structure. While the current SS circuit is held with saddle supports in compression below the piping and components, the Li circuit must be supported differently. Because of concern about self-welding and compatibility with refractory metals at points of contact, the support couplings will be attached to the circuit structure and will accommodate motion by moving links and cables. These moving links will be attached to the supporting frame in tension and be free to swing within a predetermined thermal motion range. All appurtenances within the chamber will be designed according to UHV design practice to eliminate virtual leaks and allow easy cleaning.

6.2 Assembly and Facilities Integration

Basically, a liquid-metal circuit consists of pipes, tanks, valves, pumps, heaters, and controls to circulate and maintain the liquid-metal fluid at temperatures selected for the test or experiment being conducted. Alkali liquid metals are considered to be hazardous materials and special attention must be given to the design of the circuit.

Most liquid-metal circuits require a supply tank to fill the circuit, an expansion tank to accommodate liquid-metal expansion during heatup, a cold/hot trap tank to remove precipitated oxides, and a drain tank to contain the flushed liquid metals and contaminants from the circuit. Tank, piping, pump and valve heaters, and insulation materials are required and used to maintain desired uniform circuit temperatures. An EM pump is used to circulate the liquid metal around the circuit, through the cold/hot trap, and through the test article at desired flow rates and temperatures. A vacuum and cover gas system is required to evacuate and purge the circuit of air, noncondensables and moisture, and to provide a vacuum and gas pressure during filling of the circuit with liquid metal.

All parts of the liquid-metal circuit exposed to alkali metals must remain compatible throughout the circuit and the test article during the duration of the operating and experimental test schedule. Many welds are required to construct a liquid-metal circuit comprised of the parts and components mentioned previously. Bellows-type control valves are required to maintain a leak-free and leak-tight liquid-metal system at all temperatures. Operation of bellows-type valves with frozen metal in the bellows will rupture the bellows and become the source of leaks and contamination. Most valves are manually operated. Liquid-metal circuit operating procedures must consider emergencies and unpredictable power failures.

As stated previously, the instrumentation and sensors required to operate a liquid-metal circuit must ensure sensitivity and accuracy of flow circuit operation and test article data for the anticipated range of temperatures, pressures, fluid flows, liquid levels, stresses and deformations, power levels, working fluid purity levels, and the reliability and compatibility with flow circuit and test article materials.

To ensure reliable and responsive operation of an alkali liquid-metal circuit, attention to the characteristics of the specific liquid metal and compatibility of the materials used to construct the circuit must always be kept in mind during design, fabrication, assembly, operation, and testing of the selected test articles. Sections 6.2.1 through 6.3.9 briefly identify some of the issues and precautions involved.

6.2.1 Preassembly and Quality Control

The preassembly work stations and work areas for liquid-metal components and systems must be designated, controlled, kept clean, properly equipped, and provided with acceptable materials and approved procedures to ensure traceability and reliability of liquid-metal circuits. The use of refractory metals for construction of refractory metal components and subsystems requires specific procedures to prevent contamination.

6.2.2 Test Station Preparation and Checkout

Preparation and checkout of the test station, test article, and flow circuit can be executed in stages as required. The test station is identified as the portion of the flow circuit that holds the test article. For evaluation of refractory metal components and subsystems, test chamber vacuum pressures of 10^{-7} torr or lower are required, depending on the refractory metal under consideration and the total desired life of the test hardware when at the design temperature of the components or subsystems.

There are three options for integrated test station and test article checkout acceptance prior to the scheduled test operation: (1) Installation of a bypass pipe spool to take the place of the test article and

enable operation of the flow circuit at the planned test conditions including temperatures, flows, pressures, liquid-metal purity levels, etc.; (2) installation of the test article with some possible restrictions on checkout temperatures, flows, pressures, and liquid-metal impurity levels; and (3) installation of both the test article and a bypass pipe spool at the same time. The third option provides the most flexibility during the integrated flow circuit checkout and could foreshorten the overall test schedule.

6.2.3 Test Article Installation and Integration

Early identification of the interface requirements between the test article, test section, and liquid-metal flow circuit during the design period will significantly reduce technical issues encountered during test article integration and evaluation. Transition couplings/connections between SS components and refractory metal components will be required. Thereafter, the changes in interface requirements must precede the modification of the test station and/or flow circuit.

Inspection and acceptance of the interface connections will be required to ensure functionality, metallurgical compatibility, and safety of the test article and flow loop. Adaptation of the liquid-metal circuit after liquid-metal filling and wetting pose additional issues that must be considered to ensure all technical and safety measures are addressed. The agenda for the Safety and Test Readiness Review should be prepared and distributed to permit time for proper preparation and identification of all issues to be resolved before the start of testing.

6.3 Circuit Operations

6.3.1 Preliquid Metal Loading

Purging, evacuation, heating, outgassing, and leakup tests should be performed prior to liquid-metal loading. The vacuum should enable use of a residual gas analyzer to determine outgas constituents and partial pressures of contaminants.

6.3.2 Liquid-Metal Loading

The first experience loading liquid metals NaK, Na, or Li into a virgin liquid-metal circuit can be awesome and stressful. It is extremely important to use a detailed time-based loading procedure that includes initial heatup and circulation of the liquid metal. Several dry runs using the detailed procedure should be made to ensure that all personnel involved understand the sequential steps, precautions, circuit parameters and control, and options if unforeseen conditions occur. Typical challenges that can and may occur include the following:

- Circuit piping, valves, and component temperatures are too low for the liquid metal being loaded.
- Temperatures of the liquid metal being loaded are too low to begin the filling procedure.
- The choice of filters between the fill tank and circuit to be filled may be too restrictive. The filter for NaK may not be appropriate for Li. Filters for NaK and Na will prevent precipitates from entering

the circuit, thus lowering the concentration. As a general rule, filters for Li will not reduce oxygen concentrations of the Li being loaded into the circuit.

- Evacuation of circuit sections to be filled with liquid metal has not been achieved or determined.
- Liquid-metal circuit valves are not properly set for initial loading of the liquid-metal circuit.
- Inert gas supply and pressure regulation to accomplish initial filling is uncertain and/or inadequate.
- Expansion tank liquid-metal level indications do not correlate with changes in fill-tank liquid volume/weight due to temperature/density factors or entrapped gas in the circuit or other factors.
- The EM pump-induced flow, if possible after initial filling is completed, is opposite that intended and/or the magnetic flowmeter polarity is opposite that intended.
- Inert gas bubbles are trapped in the bellow valves, pump duct, or other unforeseen sections of the liquid-metal circuit.
- Liquid-metal pressure sensors do not respond to changes in expansion tank gas pressures.
- Other challenges to be determined.

6.3.3 Initial Circulation

The start of initial circulation after energizing the EM pump is not predictable because of the many conditions that must occur beforehand, such as the following:

- Coupling between the EM pump and liquid metal in the pump duct will be reduced if the duct walls are not wetted. The time to wet the duct depends on the amount of surface contamination and the duct temperature. Increasing the temperature improves wetting.
- There is trapped gas in the pump duct. Increasing the gas pressure in the expansion tank will decrease the size of the gas bubbles and make them easier to remove by entrainment.
- ALIP or FLIP pump coils are wired improperly, which occurs more frequently than expected. Proper inspection of the coil winding and orientation is required before installation of the EM pump. Note that the initial power setting for induction EM pumps should not exceed 15%–20% of the predicted flow to prevent the pump duct from overheating when no flow exists during initial circulation.
- Wetting removes surface contamination and increases the level of impurities in the circulating liquid metal. Ideally, the contamination level of the liquid-metal NaK and Na should be kept <100 ppm to prevent plugging in colder sections (<300 °C). The precipitation temperature of Na at this impurity level is 300 °C.

6.3.4 Oxide Levels and Cold Trapping

Many technical papers have been prepared that describe designs, calibration techniques, and use of oxygen impurity meters (plugging valves, etc). Also, many technical papers on cold traps have been prepared that describe the design, size determination, fabrication details, optimum flow, and impurity reduction expectations.²⁰ Lithium-filled circuits require hot traps using getter materials to reduce the oxygen concentration below ≈ 100 ppm.

If the circuit does not have an oxide impurity meter and cold trap, then the oxide level of the initial liquid fill will depend on the oxide level in the fill tank, the temperature of the filter, and the capability of the filter to remove precipitates during the filling procedure. Oxide concentrations in Li cannot be reduced below ≈ 100 ppm by cold trapping.

Experience shows that the increase in the oxide impurity level will follow the increase in the circuit temperature until the circuit and components are completely wetted. At the highest temperature of the circuit, without a cold trap, the oxide level of the liquid metal will be the highest and the reduction in circuit temperature thereafter will cause supersaturation, precipitation, potential plugging of the coldest parts of the circuit, and possible reduction or loss of flow. A loss of flow presents new challenges too numerous to describe in this TM.

The recommended procedure to follow would be to hot-flush/drain the liquid metal into a drain tank. If no drain tank exists, then drain the hot-liquid metal back into the fill tank. After several days of cooling to a temperature slightly above the melting temperature, oxide precipitation in the fill tank will occur.

6.3.5 Temperature, Pressure, Liquid Level, and Flow Control

Control of temperature variations throughout the liquid-metal circuit is significantly more difficult and more important than the actual temperature of a component or pipe section. Large initial temperature variations can result in oxide precipitations if the circuit does not have a cold trap. Long-duration temperature variations can result in some forms of mass transfer.

Control of the inert cover gas pressure in the expansion tank will affect the EM pump inlet pressure, and if too low, will permit cavitation to occur. The interfaces between inert gas supply lines and the liquid-metal circuit must be separated by vapor traps to prevent liquid-metal vapor condensation in the gas supply lines.

Liquid-metal pressure sensors were discussed in previous sections of this TM. Extreme pressures in liquid-metal filled pipe sections can occur during heatup if the pipe sections are isolated by closed valves. During heatup, every section of the circuit must be vented to the expansion tank to accommodate thermal expansion of the liquid metal.

Liquid-level monitoring of the interface between the liquid metal in the expansion tank and the inert cover gas can be achieved using simple probes that indicate the electrical connection with the conducting liquid metal. Other liquid-level sensors that are enclosed in thimbles/tubes indicate the variation in the inductive reactance of an electrical coil that is caused by the level of liquid metal that surrounds the thimble/tube and coil. The electrical coil must operate at the temperatures of the liquid metal.

6.3.6 Test Parameters, Duration, and Data Acquisition

Test plans and test procedures identify the desired test parameters/levels, duration at each test level, and the data requirements and frequency for data acquisition. Changes between test levels will require additional operator attention to maintain uniformity of the specified temperature gradients throughout the liquid-metal circuit. For example, during heatup, sections of the circuit having more mass may take longer to reach the desired temperature.

6.3.7 Off-Normal Operations and Emergency Actions

Test plans and test procedures should identify the off-normal conditions of the liquid-metal circuit and the actions to be taken to accommodate the off-normal condition. For example, if a liquid-metal leak is observed during testing at temperature, certain procedures should be followed to reduce the hazard of the leaking and leaked liquid metal. Generally, the liquid metal in the circuit would be drained to the drain tank. The sequential steps would include opening the drain valve to the drain tank. The time to drain the circuit would be reduced if the drain tank were evacuated beforehand in anticipation of the need to drain the circuit. Other off-normal operations should be considered as well. The SP-100 Program demonstrated the procedures to distill Li away from a leak, cut out a damaged loop section, and reweld new components or piping on test loop 2. The procedures developed by SP-100 could be used in this circuit should a leak occur.

6.3.8 Test Termination and Standby

Test plans and test procedures should identify the posttest condition, anticipated duration, and standby maintenance of the liquid-metal circuit and test station/article following test completion or termination. What and when will the next operation begin and will the circuit be drained or not drained during this period of time?

6.3.9 Removal of Test Article

The procedures to remove and/or disconnect the test article from the liquid-metal circuit and test station interfaces should be considered and included in the test plans and test procedures to ensure safety during the removal tasks and proper handling of the test article.

7. SUMMARY

The focus of this study was to determine a ROM estimate for both cost and schedule in fabricating pumped alkali metal flow circuits from Mo and Ta refractory metal alloys. The ReLiC layout is based on the NRPCT task at the Early Flight Fission-Test Facilities for a SLiC. In addition to providing a ROM estimate, general information regarding material chemistry, properties, fabrication, and welding techniques are included. A top-level description is provided for potential pump and instrumentation options along with a general philosophy regarding the assembly and testing of an alkali metal flow circuit.

Molybdenum-alloy material quotations were received from the following three vendors: (1) Rhenium Alloys Inc., (2) PMTI, and (3) Schwarzkopf/Plansee for raw materials required to fabricate the ReLiC. Currently, PM formation is the primary material production method commercially offered by industry with 44.5%Re and 47.5%Re alloys supplied by Rhenium Alloys Inc., and a 41%Re alloy from Schwarzkopf. Manufacture of the ReLiC components from raw materials and final assembly into a flow circuit was estimated. This included an estimate for the engineering work and experimentation required to develop detailed procedures governing the cleaning, handling, machining, welding, etc. of the raw materials to form completed circuit components. In addition, this estimate included equipment needs to support material processing during fabrication and final assembly at the test chamber. The final circuit integration will also require engineering and procurement support for a number of ancillary systems (such as supports, containment, EM pump, heaters, insulation, instrumentation/data systems, alkali metal handling, etc.). The final cost to fabricate and assemble the ReLiC is estimated at \$9,000k assuming the use of PM material and no significant manufacturing difficulties. The timeframe to accomplish this task would be \approx 30 mo, assuming both the materials and fabrication equipment are readily available. This study also assumed that the purified Li would be provided by a source outside the scope of this ROM estimate. Testing of the flow circuit is not included.

In general, Ta alloys offer the advantages of having readily available suppliers and previous hardware programs that demonstrated the ability to manufacture complex parts. However, the Ta alloys carry concerns that include an increase in weldment cracking and higher susceptibility to oxidation and hydrogen embrittlement (as compared to Mo-Re alloys). Material estimates were obtained from Wah Chang and PMTI for raw materials required to fabricate the ReLiC. Manufacture of the ReLiC components from raw materials and final assembly into a flow circuit was estimated. This included an estimate for the engineering work and experimentation required to develop detailed procedures governing the cleaning, handling, machining, welding, etc. of the raw materials to form completed circuit components. The baseline fabrication was estimated on the use of Ta-10W alloy. (It was expected that T-111 would increase the fabrication estimate by 25% and the use of ASTAR-811 by 50%.) In addition, this estimate included equipment needs to support material processing during fabrication and final assembly at the test chamber. The final circuit integration will also require engineering and procurement support for a number of ancillary systems such as supports, containment, EM pump, heaters, insulation, instrumentation/data systems, alkali metal handling, etc. The final cost to fabricate and assemble the ReLiC is estimated

at \$12,000k assuming no significant manufacturing difficulties. The timeframe to accomplish this task would be \approx 36 mo, assuming both materials and fabrication equipment are readily available. This study also assumed that the purified Li supply would be provided by a source outside the scope of this ROM estimate. Testing of the flow circuit is not included.

APPENDIX—ALKALI METAL FLOW CIRCUIT ENGINEERING DRAWINGS

The alkali metal flow circuit engineering drawings that were used for quotation purposes are shown in figure 13.

Figure 13. Flow circuit assembly drawing set 90M11881 (latest update 11-12-2004) (Continued).

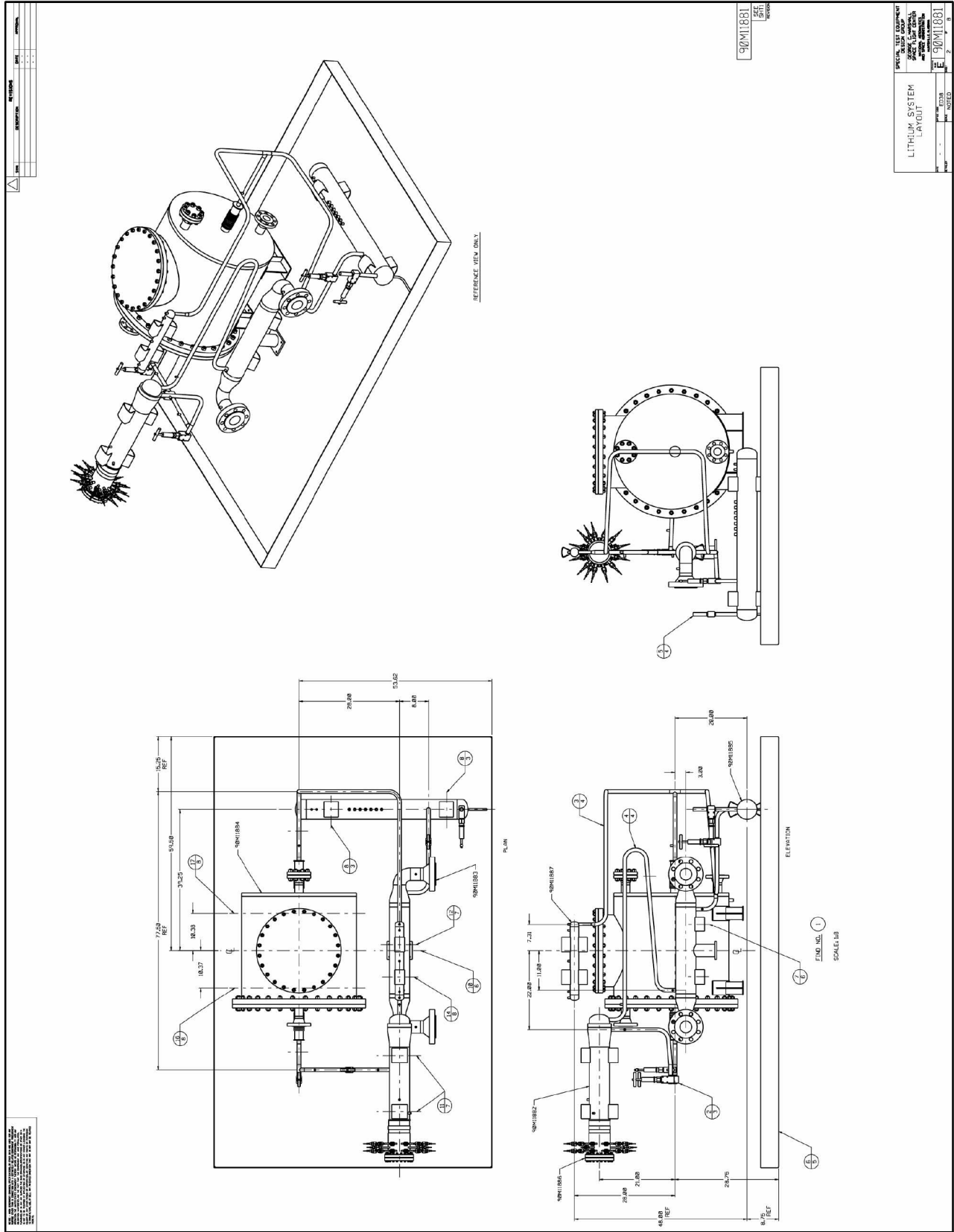

REFERENCES

1. Bryhan, J.: "Fabrication and Operation of Lithium Test Circuit-2," *MSNP-00001*, April 1993.
2. Buckman, Jr., R.W.; and Goodspeed, R.C.: "Precipitation Strengthened Tantalum Base Alloy, ASTAR-811C," *NASA CR-1641*, Lewis Research Center, Cleveland, OH, March 1971.
3. Kramer, D.P.; Ruhkamp, J.D.; McNeil, D.C.; et al.: "Investigation of Molybdenum-44.5%Rhenium as Cell Wall Material in an AMTEC Based Space Power System," M.S. El-Ghenk (ed.), *AIP Conf. Proc.*, Vol. 504, Issue 2, pp. 1402-1407, 2000.
4. Klopp, W.D.: "Review of Ductilizing of Group VIA Elements by Rhenium and Other Solutes," *NASA TN D-4955*, Lewis Research Center, Cleveland, OH, August 1968.
5. Klopp, W.D.; and Witzke, W.R.: "Mechanical Properties of Electron-Beam-Melted Molybdenum and Dilute Molybdenum-Rhenium Alloys," *NASA TM X-2576*, Lewis Research Center, Cleveland, OH, June 1972.
6. Merrigan, M.A.; and Lundberg, L.B., "Initial Evaluation of Molybdenum-Rhenium Alloy for Reactor Heat Pipes," *Proc. 18th IECEC*, Vol. 4, pp. 1880-1886, 1983.
7. Ammon, R.L.; and Buckman, Jr., R.W.: "Observations on the As-Welded (GTAW) Bend Ductility of Mo-13% Re Alloy," M.S. El-Ghenk and M.D. Hoover (eds.), in *Space Nuclear Power Systems 1986*, Orbit Book Company, Malabar, FL, pp. 283-290, 1987.
8. Klopp, W.D.: *Technology Status of Molybdenum and Tungsten Alloys*, M.S. El-Ghenk and M.D. Hoover (eds.), in *Space Nuclear Power Systems 1984*, Orbit Book Company, Malabar, FL, pp. 359-370, 1985.
9. Carlen, J.C.; and Bryskin, B.D.: "Concerning Sigma-Phase in Molybdenum-Rhenium Alloys," *J. Mater. Eng. Perform.*, Vol. 3, No. 2, pp. 282-291, April 1994.
10. Povarova, K.B.; Kasanskaia, N.K.; Bannikh, O.A.; et al.: "High Rhenium Binary and Ternary Alloys With Tungsten and Molybdenum for Service in Nitrogen- and Hydrogen-Containing Environments," B.D. Bryskin (ed.), *Rhenium and Rhenium Alloys*, pp. 605-619, 1997.
11. Leonhardt, T.; Carlén, J.-C.; Buck, M.; et al.: "Investigation of Mechanical Properties and Microstructure of Various Molybdenum-Rhenium Alloys," M.S. El-Ghenk (ed.), *AIP Conf. Proc.*, Vol. 458, Issue 1, pp. 685-690, January 22, 1999.

12. Klopp, W.D.; and Raffo, P.L.: "Effects of Purity and Structure on Recrystallization, Grain Growth, Ductility, Tensile, and Creep Properties of Arc-Melted Tungsten," *NASA TN D-2503*, Lewis Research Center, Cleveland, OH, 1964.
13. Morito, F.: "Microstructure and Mechanical Behaviors of Mo-Re Welds," *High Temperatures – High Pressures*, Vol. 26, pp. 101–108, 1994.
14. Wadsworth, J.; Nieh, T.G.; and Stephens, J.J.: "Dilute Mo-Re Alloys—A Critical Evaluation of Their Comparative Mechanical Properties," *Scripta Metallurgica*, Vol. 20, Issue 5, pp. 637–642, May 1986.
15. Morito, F.: "Structures and Properties of Molybdenum-Rhenium Alloys," B.D. Bryskin (ed.), *Rhenium and Rhenium Alloys*, Orlando, FL, pp. 559–568, 1997.
16. Moore, J.P.; King, J.F.; DiStefano, J.R.; and Ohriner, E.K.: "Production and Properties of Mo-41%Re for AMTEC Cell Construction," M.S. El-Ghenk (ed.), *AIP Conf. Proc.*, Vol. 608, pp. 963–971, January 14, 2002.
17. Cooper, Jr., R.H.; and Hoffman, E.E.: "Refractory Alloy Technology for Space Nuclear Power Applications," *Proc. Symp. on Refractory Alloy Technol. for Space Nucl. Power Appl.*, OSTI Id. 7122878, January 1984.
18. Buckman, Jr., R.W.: "A Review of Ta and Nb Alloy Production," *Refractory Alloy Technology for Space Nuclear Power Applications*, Editors Cooper and Hoffman, ORNL/DOE, OSTI Id. 7122878, pp. 86–97, January 1984.
19. Lessmann, G.G.: "Welding of Refractory Alloys," R.H. Cooper, Jr. and E.E. Hoffman (eds.), *Proc. Symp. on Refractory Alloy Technol. for Space Nucl. Power Appl.*, OSTI Id. 7122878, pp. 146–167, January 1984.
20. Lessmann, G.G.: "Interaction of High Temperature Strength and Weldability," *Weld. J.*, Vol. 52, No. 7, pp. 312s–321s, July 1973.
21. Young, W.R.: "Refractory Alloy Component Fabrication," R.H. Cooper, Jr. and E.E. Hoffman (eds.), Report CONF-8308130, NTIS, in *Proc. Symp. on Refractory Alloy Technol. for Space Nucl. Power Appl.*, pp. 168–226, January 1984.
22. Mausteller, J.W.; Tepper, F.; and Rodgers, S.J.: *Alkali Metal Handling and Systems Operating Techniques*, Gordon and Breach Science Publishers, New York, 241 pp., 1968.
23. Borgstedt, H.U.; and Mathews, C.K.: *Applied Chemistry of the Alkali Metals*, Plenum Press, New York, 1987.

REPORT DOCUMENTATION PAGE

Form Approved
OMB No. 0704-0188

The public reporting burden for this collection of information is estimated to average 1 hour per response, including the time for reviewing instructions, searching existing data sources, gathering and maintaining the data needed, and completing and reviewing the collection of information. Send comments regarding this burden estimate or any other aspect of this collection of information, including suggestions for reducing this burden, to Department of Defense, Washington Headquarters Services, Directorate for Information Operation and Reports (0704-0188), 1215 Jefferson Davis Highway, Suite 1204, Arlington, VA 22202-4302. Respondents should be aware that notwithstanding any other provision of law, no person shall be subject to any penalty for failing to comply with a collection of information if it does not display a currently valid OMB control number.

PLEASE DO NOT RETURN YOUR FORM TO THE ABOVE ADDRESS.

1. REPORT DATE (DD-MM-YYYY) 01-05-2010		2. REPORT TYPE Technical Memorandum		3. DATES COVERED (From - To)	
4. TITLE AND SUBTITLE Cost Estimate for Molybdenum and Tantalum Refractory Metal Alloy Flow Circuit Concepts				5a. CONTRACT NUMBER	
				5b. GRANT NUMBER	
				5c. PROGRAM ELEMENT NUMBER	
6. AUTHOR(S) R.R. Hickman, J.J. Martin, G.R. Schmidt, T.J. Godfroy, and A.J. Bryhan*				5d. PROJECT NUMBER	
				5e. TASK NUMBER	
				5f. WORK UNIT NUMBER	
7. PERFORMING ORGANIZATION NAME(S) AND ADDRESS(ES) George C. Marshall Space Flight Center Marshall Space Flight Center, AL 35812				8. PERFORMING ORGANIZATION REPORT NUMBER M-1280	
9. SPONSORING/MONITORING AGENCY NAME(S) AND ADDRESS(ES) National Aeronautics and Space Administration Washington, DC 20546-0001				10. SPONSORING/MONITOR'S ACRONYM(S) NASA	
				11. SPONSORING/MONITORING REPORT NUMBER NASA/TM-2010-216431	
12. DISTRIBUTION/AVAILABILITY STATEMENT Unclassified-Unlimited Subject Category 20 Availability: NASA CASI (443-757-5802)					
13. SUPPLEMENTARY NOTES Prepared by the Propulsion Systems Department, Engineering Directorate *Minimal Technology, Inc., San Jose, CA					
14. ABSTRACT The Early Flight Fission-Test Facilities (EFF-TF) team at NASA Marshall Space Flight Center (MSFC) has been tasked by the Naval Reactors Prime Contract Team (NRPCT) to provide a cost and delivery rough order of magnitude estimate for a refractory metal-based lithium (Li) flow circuit. The design is based on the stainless steel Li flow circuit that is currently being assembled for an NRPCT task underway at the EFF-TF. While geometrically the flow circuit is not representative of a final flight prototype, knowledge has been gained to quantify (time and cost) the materials, manufacturing, fabrication, assembly, and operations to produce a testable configuration. This Technical Memorandum (TM) also identifies the following key issues that need to be addressed by the fabrication process: Alloy selection and forming, cost and availability, welding, bending, machining, assembly, and instrumentation. Several candidate materials were identified by NRPCT including molybdenum (Mo) alloy (Mo-47.5%Re), tantalum (Ta) alloys (T-111, ASTAR-811C), and niobium (Nb) alloy (Nb-1%Zr). This TM is focused only on the Mo and Ta alloys, since they are of higher concern to the ongoing effort. The initial estimate to complete a Mo-47%Re system ready for testing is ~\$9,000k over a period of 30 mo. The initial estimate to complete a T-111 or ASTAR-811C system ready for testing is ~\$12,000k over a period of 36 mo.					
15. SUBJECT TERMS flow loops, flow circuits, lithium, tantalum, welding, corrosion, material properties					
16. SECURITY CLASSIFICATION OF:			17. LIMITATION OF ABSTRACT UU	18. NUMBER OF PAGES 56	19a. NAME OF RESPONSIBLE PERSON STI Help Desk at email: help@sti.nasa.gov
a. REPORT U	b. ABSTRACT U	c. THIS PAGE U			19b. TELEPHONE NUMBER (Include area code) STI Help Desk at: 443-757-5802

National Aeronautics and
Space Administration
IS20
George C. Marshall Space Flight Center
Marshall Space Flight Center, Alabama
35812