

Proposed Schematics for an Advanced Development Lunar Portable Life Support System

Bruce Conger¹

Hamilton Sundstrand, Houston, Texas 77058

Cinda Chullen²

NASA, 2102 NASA Parkway, Houston, Texas 77058

Bruce Barnes³

Jacobs Engineering, Houston, Texas 77058

and

Greg Leavitt⁴

Wyle Integrated Science and Engineering Group, Houston, Texas 77058

The latest development of the NASA space suit is an integrated assembly made up of primarily a Pressure Garment System (PGS) and a Portable Life Support System (PLSS). The PLSS is further composed of an oxygen (O₂) subsystem, a ventilation subsystem, and a thermal subsystem. This paper baselines a detailed schematic of the PLSS to provide a basis for current and future PLSS development efforts. Both context diagrams and detailed schematics describe the hardware components and overall functions for all three of the PLSS subsystems. The various modes of operations for the PLSS are also presented. A comparison of the proposed PLSS to the Apollo and Shuttle PLSS designs is presented, highlighting several anticipated improvements over the historical PLSS architectures.

Nomenclature

<i>Btu</i>	= British thermal unit
<i>CM</i>	= crew member
<i>CO₂</i>	= carbon dioxide
<i>DCM</i>	= Display and Controls Module
<i>DCS</i>	= decompression sickness
<i>ECLSS</i>	= Environmental Control and Life Support System
<i>EMU</i>	= Extravehicular Mobility Unit
<i>EVA</i>	= extravehicular activity
<i>GSE</i>	= ground support equipment
<i>H₂O</i>	= water
<i>ISS</i>	= International Space Station
<i>IVA</i>	= Intravehicular Activity
<i>JSC</i>	= Johnson Space Center
<i>lbm</i>	= pounds mass
<i>LCVG</i>	= liquid cooling and ventilation garment
<i>LiOH</i>	= lithium hydroxide
<i>Metox</i>	= metal oxide
<i>micro-g</i>	= microgravity
<i>NASA</i>	= National Aeronautics and Space Administration

¹ Project Manager, Thermal and Environmental Analysis, 2224 Bay Area Blvd., Houston, Texas 77058/JE-5EA.

² Project Engineer, Space Suit and Crew Survival Systems Branch, 2102 NASA Parkway, Houston, Texas/EC5.

³ Thermal Engineer, Thermal and Environmental Analysis, 2224 Bay Area Blvd., Houston, Texas 77058/JE-5EA.

⁴ Systems Engineer, System Engineering, 1300 Hercules Drive, Houston, Texas 77058/FH-W5.

O_2	= oxygen
Pa	= Pascal
$PCAI$	= Power, Communication, Avionics, and Informatics
PGS	= Pressure Garment System
$PLSS$	= Portable Life Support System
psi	= pounds per square inch differential
$psia$	= pounds per square inch absolute
$psid$	= pounds per square inch differential
RCA	= Rapid Cycle Amine
SOP	= secondary oxygen pack
$SWME$	= Spacesuit Water Membrane Evaporator
TCV	= Temperature Control Valve
TD	= Thermal Desktop™
W	= Watts

I. Introduction

THE space-suited astronaut is the ultimate symbol of human exploration.¹ The space suit provides for distinct protection of a single crew member (CM) working and operating in challenging extravehicular activity (EVA) environments. The space suit is often referred to as a “mini or one-person spacecraft” because of this EVA distinction. One of the most complex aspects of this distinct EVA protection is the life support function of the space suit. Due to the need to be mobile during EVA and self-contained, the space suit must provide a unique approach to the CM’s overall life support. This paper focuses on the future exploration life support system architecture for the EVA-unique portable aspects associated with the Portable Life Support System (PLSS).

The effort to select the baseline PLSS architecture for future exploration activities was completed and documented in 2007.² This paper identifies additional details for the baseline schematic. In particular, details the fluid lines of the baseline schematic are provided in a manner that identifies useful PLSS functions in various operational scenarios, while attempting to minimize complexity. This baseline schematic was reviewed by the National Aeronautics and Space Administration (NASA), Johnson Space Center (JSC) PLSS development team. It underwent updates resulting from various evaluations. This schematic design is not intended to be a final design, but is intended to be a theoretically workable, but unproven, layout for use as the basis for future efforts. The information in this paper was based on design and analysis cycles and technology development work completed through September 2009. Overall, the detailed schematic with component numbers and descriptions are documented in 2008³ and 2009⁴.

PLSS functions described within this paper include the operational scenarios: charging operations, nominal operations, and contingency operations. The focus is the fluid-related components within the PLSS. Electronic and power devices are mentioned, including an emphasis on major interfaces of electronic equipment with the fluid systems.

Additionally, a comparison of the baseline PLSS to the Apollo and the current Space Shuttle/International Space Station (ISS) EVA PLSS to support mission options is provided.

II. System Requirements and Assumptions

The EVA System consists of three internal elements that interface: suit element, vehicle interface, and tools & equipment. These elements are necessary to protect crewmembers and allow them to work effectively in the pressure and thermal environments that exceed the human capability during all crewed mission phases.

The space suit contains three systems: the PLSS, the Pressure Garment System (PGS), and the Power, Communications, Avionics, and Informatics (PCAI) system. The space suit is necessary to support extravehicular planetary exploration on the Moon and Mars. The space suit functions include:

- Maintain pressure on the CM
- Deliver breathing gas to the CM
- Maintain core body temperature of the CM
- Provide the mobility to perform required tasks
- Provide communications to and from the CMs
- Provide CM biomedical data

- Protect the CM during launch, entry and abort
- Protect the CM from the environment during EVA
- Provide CM waste management

The PLSS is envisioned to be worn as a backpack to the PGS, a multi-layered space suit under development, which together constitutes the EVA capability along with the associated PCAI and the ground support equipment (GSE). Figure 1, represents a simplified rendition of the baseline PLSS functions for explanatory purposes.⁵ The PLSS consists of the O₂ subsystem, the ventilation subsystem, and the thermal control subsystem. The PLSS houses PCAI system components that provide communications, avionics, and the information systems. However, the focus of this paper is on the fluid subsystems. The O₂ subsystem provides O₂ to the CM for breathing through the ventilation subsystem. The ventilation subsystem receives the CM expired components of O₂, CO₂, and H₂O and processes them through a regenerable scrubber where the CO₂ and H₂O are vented to vacuum. This regenerable aspect of the scrubber allows it to be reused resulting in consumable savings over historical designs. The thermal subsystem provides cool water to the suit for CM thermal comfort and receives warm H₂O back to the subsystem for conditioning. Water that is evaporated from the cooling loop is resupplied by H₂O storage within the suit. Overall, these subsystems work in unison to provide an active PLSS for the CM engaged in an EVA.

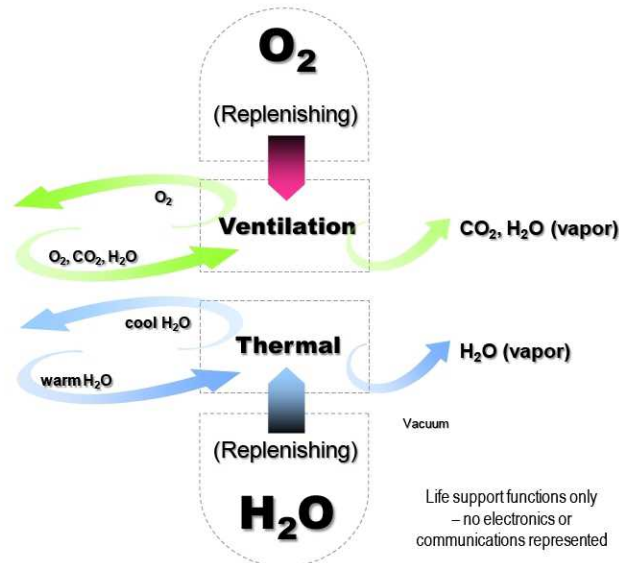

Figure 1. Simplified PLSS Functions. *The O₂, ventilation, and thermal subsystems work together to provide oxygen, thermal control, humidity control, carbon dioxide (CO₂) control and, trace contaminant control.*

Environmental control and life support systems (ECLSSs) are being designed to keep a CM alive within the confines of the crewed habitat. Although the fundamental principles of an ECLSS are the same as the PLSS, the PLSS is a smaller, more compact, and a uniquely different life support system necessitating unique requirements and assumptions.

The PLSS specifically supports the following activities:

- Preparing for an EVA
- Performing an EVA
- Performing post-EVA processing
- Supplying storage between EVAs
- Performing scheduled maintenance

This paper focuses on the functions performed by the PLSS enabling an EVA. The primary function of the PLSS is to provide critical life support capabilities for the CM. The PLSS specifically provides the following critical life support functions for the CM:

- Oxygen (O₂)
- Thermal control
- Humidity control
- Carbon Dioxide (CO₂) control
- Trace contaminant control

Requirements for the PLSS for longer microgravity use, lunar applications or even Mars missions indicate longer mission durations than Apollo with fewer opportunities for resupplying resources. Therefore, a reduction in consumables will be necessary for each EVA. A new approach was needed for the PLSS to help reduce the overall consumables for longer microgravity use, lunar and Mars mission requirements significantly. Also, to maximize flight crew productivity towards achieving exploration objectives, the required crew time for EVA preparation and maintenance activities needed to be shorter than the Space Shuttle and International Space Station (ISS) EVA times.

When the Apollo astronauts were interviewed in the 1990's to help define EVA system requirements for future missions, they agreed that appropriately automating the PLSS had advantages, but they wanted to maintain a "keep it simple" approach. They concluded that "All subsystem designs should be based on fundamental principles of simplicity and reliability. Given a trade-off, simplicity and reliability are to be preferred over added functionality."⁶

The following is a list of assumptions and requirements based on the initial PLSS architecture and the baselined system requirements as of September 2009.⁷ The PLSS shall:

- Function in lunar thermal environments, hot and cold extremes
- Function in orbital and transit (micro-g) environments
- Support EVA durations of 8 hours with an average metabolic rate of 300 W (~1,000 Btu/hour) per CM
- Maintain nominal suit pressure at 4.3 psid for EVA and 0.9 psid for Intravehicular Activity (IVA)
- Provide redundant life support for 30 minutes after a single component failure excluding catastrophic gas depressurization
- Provide life support services for two CM's using a single functional PLSS and buddy umbilical for 90 minutes to support a 10 km walk-back emergency of a life critical component failure
- Support vacuum removable capability where a second suited CM assists the first suited CM (with life support functions provided by an umbilical) in detaching the PLSS from the suit in vacuum environments while suited
- Operate with vehicle or rover configurations that supply low-pressure O₂ as well as configurations that supply high-pressure O₂ with vacuum access for subsystem operations

III. Overall Schematic

The functional diagram of the baseline PLSS is shown in Fig. 2. Gaseous O₂ storage (shown in orange and pink) provides the makeup O₂ to the ventilation loop (shown in green). A fan provides momentum to circulate the ventilation flow, which is first routed to the helmet and then into the suit. It is then picked up in the arm and leg areas of the suit by the liquid cooling and ventilation garment (LCVG). The LCVG is a relatively tight fitting garment that has water tubes sewn into it in order to cool the CM. The LCVG also includes ventilation ducting that picks up ventilation gases that have flowed over the body and returns the ventilation gases to the PLSS. The ventilation gases are then routed to the Rapid Cycle Amine (RCA) unit where CO₂ and humidity are removed.

The thermal subsystem comprises the blue components in the diagram. The pump routes cooling H₂O from the suit to the Spacesuit Water Membrane Evaporator (SWME), which is the cooling unit that removes metabolic heat and electronic heat from the PLSS and the PGS. The cooling H₂O is routed to a temperature control valve that the CM adjusts, to control the amount of cool water entering the LCVG to maintain thermal comfort. The H₂O then exits the suit and returns to the pump. Water stored in the feedwater tanks replaces the H₂O that evaporates from the SWME in the H₂O loop. The detailed baseline PLSS schematic contains additional minor components and flow paths and is shown in fig. 3.

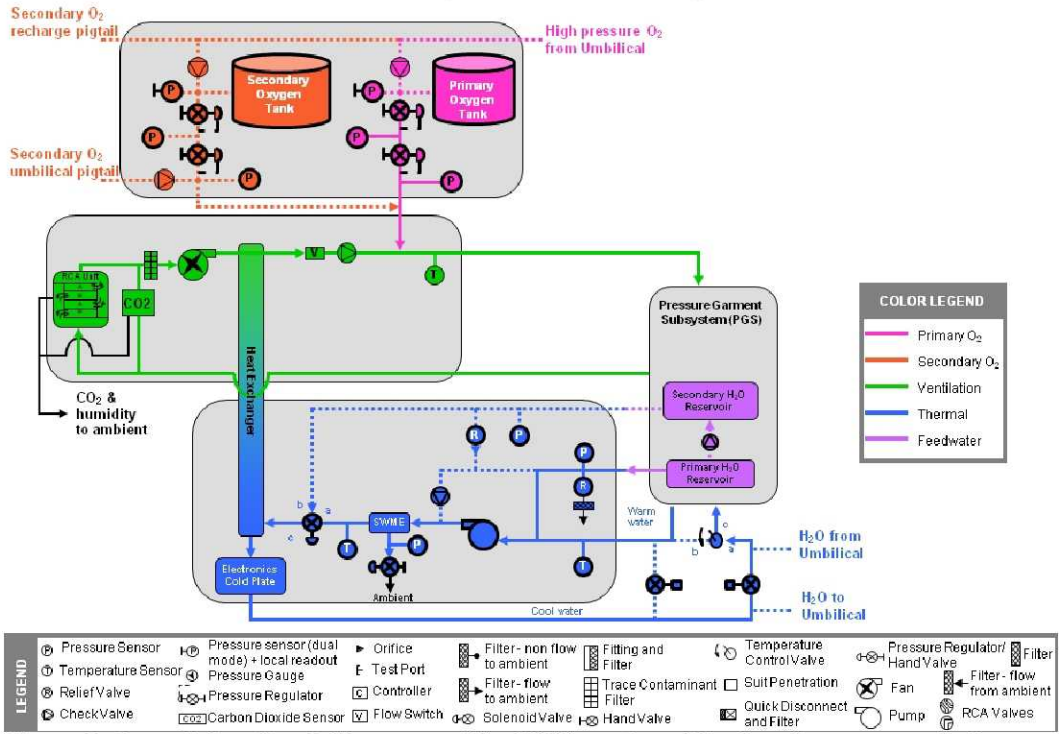

Figure 2. Overall functional diagram. *The PLSS consists of the O₂ subsystem, ventilation subsystem, and thermal subsystem.*

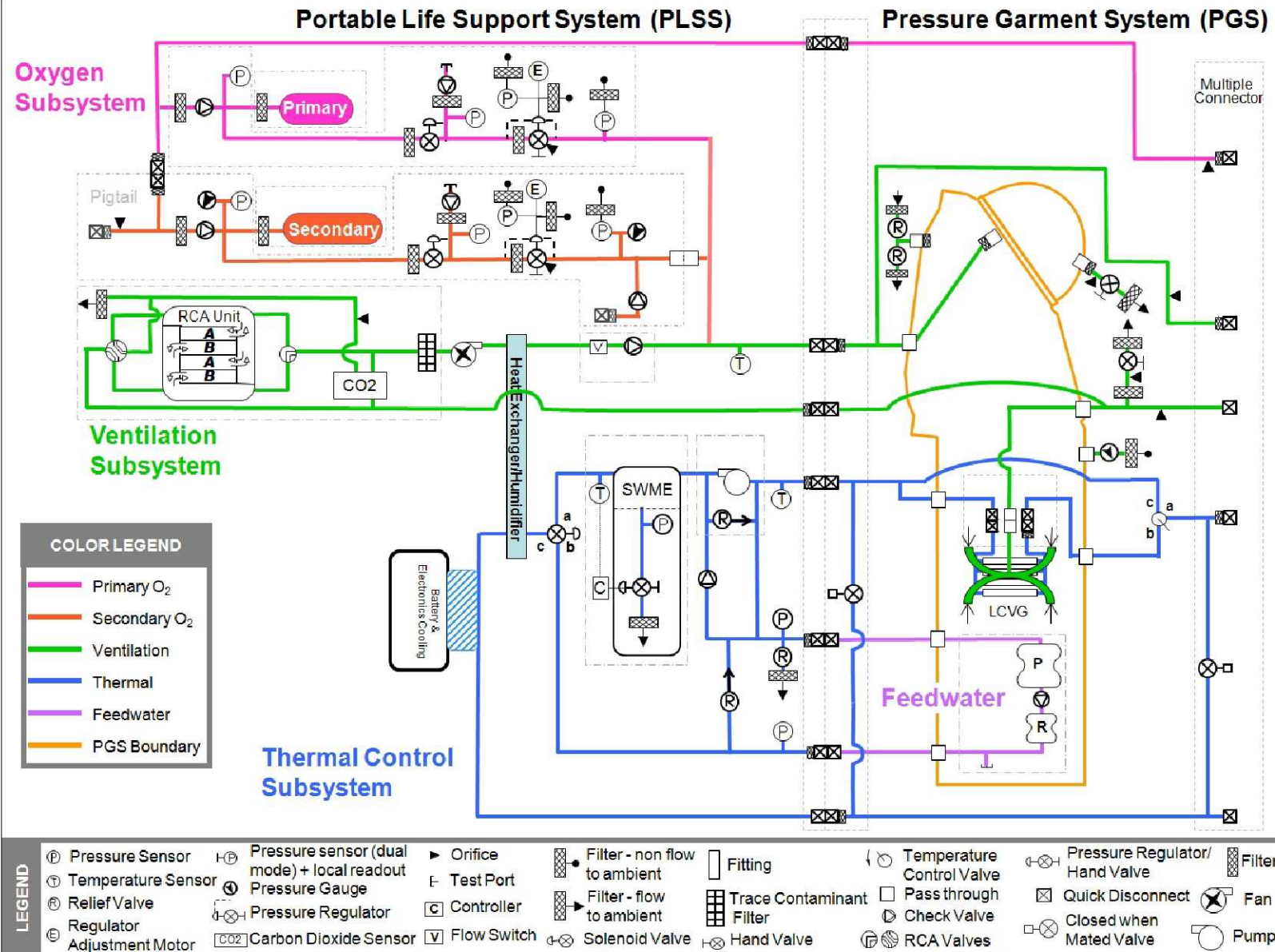

Figure 3. System Level Baseline PLSS Schematic. This schematic shows the majority of the PLSS components with the exception of fittings and some of the filters.

IV. Oxygen Subsystem

The O₂ subsystem consists of the primary and secondary O₂ storage tanks, along with the regulators that provide O₂ to the space suit at the required pressures. The O₂ tanks are refilled via the O₂ recharge line, which connects to the umbilical with a quick disconnect and filter.

The primary and secondary O₂ tank designs allow them to store O₂ at 3,000 psia nominally, when full. Single stage regulators (two for the primary and two for the secondary) function to condition the O₂ down to usable suit pressure levels of 4.3 psid for primary operations and 3.6 psid for secondary operations.

In general, the included filters protect components from potential debris in the fluid lines. All fluid lines that lead to the ambient environment include filters to prevent the lunar dust from entering these lines. This is also true for the ventilation subsystem and the thermal subsystem.

The high level functional diagram for the O₂ subsystem is shown in Fig. 4. The O₂ subsystem interfaces with the recharge umbilical for O₂ recharge of the storage tanks and provides O₂ to the ventilation subsystem. The O₂ subsystem stores the high-pressure O₂ in primary and secondary storage tanks. The primary O₂ tank nominally supplies the ventilation subsystem with regulated makeup O₂ as needed. In the event of primary O₂ system depletion or failure, the secondary system will supply the ventilation subsystem with regulated redundant O₂. Pressure sensors in the O₂ subsystem monitor both the primary and secondary O₂ tank pressures as well as the regulated intermediate pressure downstream of the tanks.

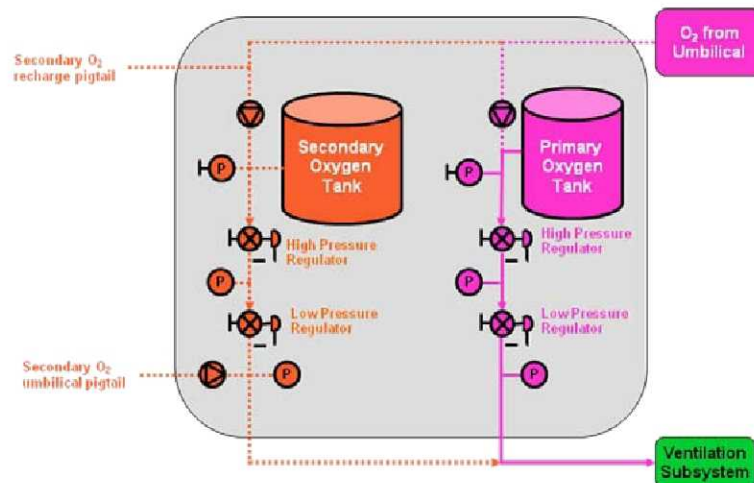

Figure 4. Oxygen subsystem functional diagram. The O₂ subsystem is recharged via high pressure O₂ delivered by the umbilical and provides regulated O₂ to the ventilation subsystem.

V. Ventilation Subsystem

The controlled flow of O₂ to and from the space suit within the ventilation subsystem is shown in Fig. 5. The vehicle or rover (both via umbilical flow) or a PLSS fan can provide flow momentum. In emergency purge mode, the CM opens one of the purge valves, as neither the fan nor the umbilical are assumed to function. The drop in suit pressure causes the secondary O₂ subsystem regulators to crack and maintain suit pressure by providing flow to the helmet.

During nominal EVA operations, the ventilation flow recycles through the ventilation loop with the Rapid Cycle Amine (RCA) providing CO₂ and humidity removal functions. Without the RCA unit, the CO₂ and humidity levels would build up rapidly to toxic levels.

The CO₂ sensor monitors concentrations of CO₂ in the ventilation loop at the suit inlet and outlet. This sensor provides information for warning the CM when high levels of CO₂ exist. It can also provide metabolic information.

Humidity levels must be controlled in the ventilation loop to provide comfort to the CM and to prevent fogging in the helmet. The RCA is very efficient at removing humidity. It is expected that humidity levels exiting the RCA

will be too dry for CM comfort. To mitigate this issue, the current design shows a humidity controller integrated with heat exchanger, as a liquid to gas membrane unit that transfers H₂O vapor from the H₂O loop to the dry ventilation stream at the exit of the RCA.

Figure 5, shows the high level functional diagram for the ventilation subsystem. The ventilation subsystem interfaces with the thermal subsystem by receiving cooling water that circulates through the heat exchanger and interfaces with the O₂ subsystem by receiving O₂ to replenish the ventilation loop. The function of the ventilation subsystem is to circulate cool breathing O₂ to the PGS. The ventilation subsystem circulates O₂ through the ventilation loop by using a fan. A heat exchanger that uses cool water from the thermal subsystem cools the O₂ before it enters the PGS. A CO₂ sensor is used to measure the levels of CO₂ entering and exiting the PGS and data obtained from the CO₂ sensor may be used to calculate the metabolic rate. Two additional sensors measure the pressure and temperature of the O₂ in the ventilation loop entering the PGS. The return flow from the PGS is scrubbed by the RCA. The RCA removes CO₂ and humidity from the ventilation loop and vents these constituents to vacuum.

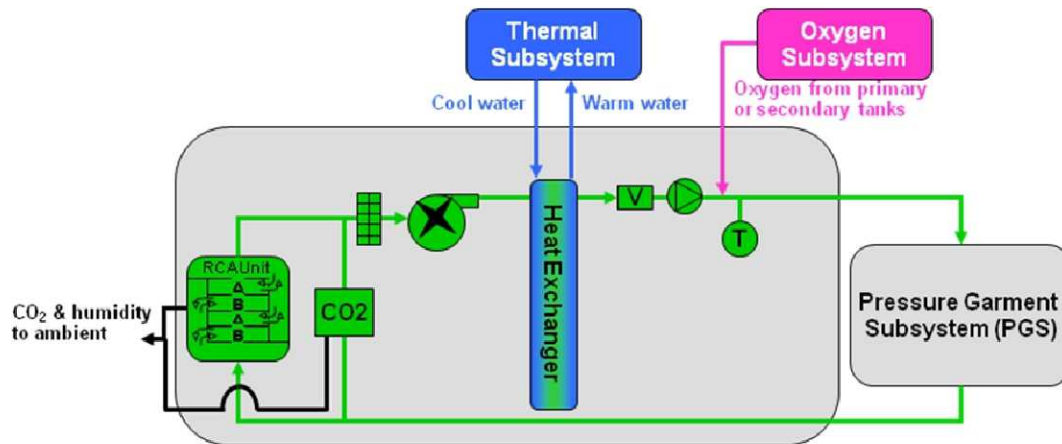

Figure 5. Ventilation subsystem functional diagram. The ventilation subsystem provides conditioned breathing gas to the PGS for CM consumption. The O₂ subsystem provides makeup oxygen to the ventilation subsystem while the thermal subsystem provides cooling water for ventilation loop gas cooling.

VI. Thermal Subsystem

Thermal comfort for the CM and temperature control of the PLSS equipment is provided by the thermal subsystem. The CM controls the amount of cooling or heating provided by the thermal subsystem by adjusting the thermal control valve. Cooling H₂O flows via the pump to the LCVG to provide the majority of a CM's cooling requirements (some sensible and evaporative cooling is provided by ventilation flow within the suit).⁸ A Spacesuit Water Membrane Evaporator (SWME) removes heat from the thermal subsystem's water loop by evaporating water through a membrane. The evaporated water is vented to the vacuum environment. Feedwater tanks provide water to replenish the thermal subsystem as water evaporates within the SWME.

The high level functional diagram for the thermal subsystem is shown in Fig. 6. The thermal subsystem interfaces with the ventilation subsystem to provide cooling water to the heat exchanger and interfaces with the PGS to provide cooling water to the CM. The function of the thermal subsystem is to provide cooling to the CM and electronic components. The thermal subsystem circulates H₂O through the H₂O loop by using a pump. The SWME cools the H₂O loop by using a control valve to evaporate a regulated amount of H₂O to ambient. The cooling water circulates through the heat exchanger for ventilation loop cooling and circulates through the electronics cold plate for electronics cooling. A heater provides additional heating to the H₂O loop, if needed, before returning to the PGS. Four pressure sensors and two temperature sensors monitor the pressure and temperature of the H₂O loop. Two feedwater reservoirs located in the PGS provide makeup H₂O to the H₂O loop. The primary feedwater reservoir nominally supplies the H₂O loop with makeup H₂O as needed. In the event of primary feedwater reservoir depletion or failure, the secondary system will supply the H₂O loop with redundant H₂O.

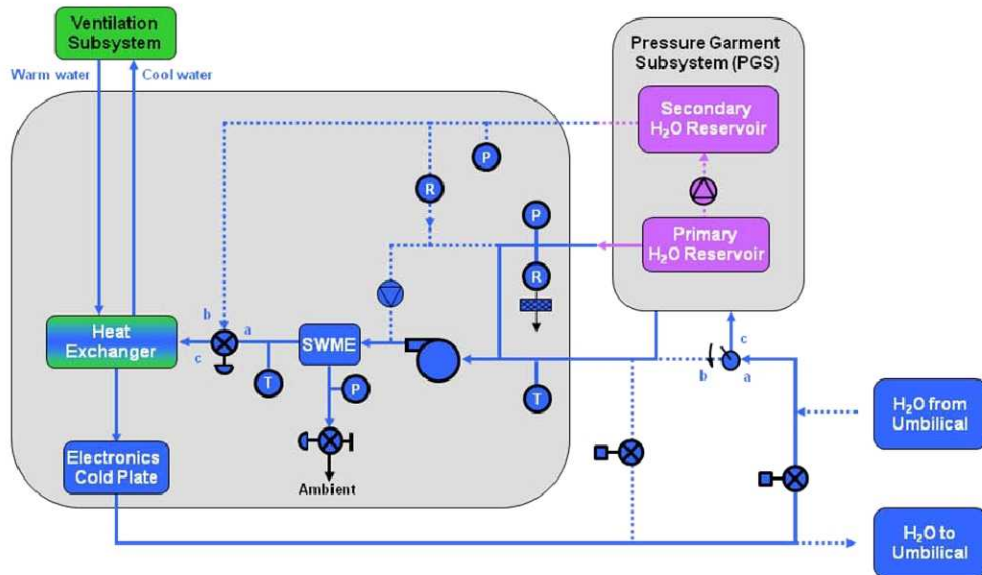

Figure 6. Thermal subsystem functional diagram. The thermal subsystem conditions the thermal loop to provide cooling to the CM. Feedwater tanks that are located in the PGS provide makeup water to the thermal subsystem. The tanks are recharged with water from the umbilical. The thermal subsystem provides cooling water to the ventilation subsystem for ventilation loop gas cooling.

VII. PLSS Modes of Operation

The PLSS has 6 primary modes of operations for lunar applications.

1. Nominal EVA - In the nominal EVA Mode, the PLSS performs autonomously to provide CM life support functions. The PLSS will rely on a low-pressure ambient environment for the SWME and RCA technologies to function.
2. Umbilical Modes – In the umbilical modes, the PLSS performs in conjunction with umbilical services.
 - No Recharge Mode - In the umbilical (no recharge mode), the umbilical provides O₂ and cooling H₂O to the CM, but neither the O₂ tanks nor the feedwater tanks are refilled.
 - Recharge Mode - The umbilical with recharge mode accomplishes refilling the O₂ and feedwater tanks during suited or unsuited conditions. Cooling water used to refill the feedwater tanks is provided by the umbilical, and the pump and the SWME are not functioning.
3. Decompression Sickness (DCS) Treatment Mode - The CM can select DCS Treatment Mode with two options, the EVA option and the umbilical option. The DCS Treatment Mode EVA option flow paths are nearly identical to the nominal EVA Mode. The DCS Treatment Mode umbilical option is nearly identical to the umbilical (no recharge mode).
4. Buddy Mode – This is a mode to cover the situation in which one CM's PLSS encounters a failure, such as a loss of power, during an EVA. The PLSS that did not encounter failure (functional PLSS) supplies the O₂ and cooling H₂O to the CM with the failed PLSS (disabled PLSS) through the Buddy umbilical. The Space Shuttle and ISS EMUs do not include a Buddy capability. The EVA CMs will travel much farther from the airlock during lunar EVAs, as compared to ISS and Shuttle EVAs with less time to retreat back to the airlock in case of failure. This mode is economical (in terms of mass and volume) emergency PLSS system design for lunar and Mars EVA support.⁸

5. Secondary O₂ Modes - The secondary O₂ modes are autonomous emergency modes where the PLSS encounters a failure and cannot rely on the Buddy Mode for whatever reason. There are three options within the secondary O₂ modes: the helmet purge option, the suit purge option, and the operational option. The secondary O₂ modes assume that low-pressure and vacuum ambient conditions exist.
6. PLSS Removed Umbilical Mode - The current operational concept for returning from a lunar mission includes the ability to doff the PLSS and leave it on the lunar surface before launching to return to earth. A possibility exists for the doffing procedure to take place at vacuum conditions. The PLSS schematic includes quick disconnects to allow for removal of the PLSS when the suited CM is relying on the umbilical for life support functions. The direction of the cooling H₂O flow through the LCVG reverses, as compared to the LCVG flow in the modes discussed previously.

This section describes the various modes of operation for the PLSS. For each mode, the overall schematic is displayed and active plumbing for that mode is highlighted. Descriptions of the functions of major components operating are presented as well as overall PLSS capabilities during each mode.

A. Nominal EVA

In the EVA Mode, the baseline PLSS performs autonomously to provide CM life support functions. The PLSS relies on a low-pressure ambient environment for the SWME and RCA technologies to function. Figure 7, shows the fluid lines that are active during the EVA Mode of operation.

In the nominal EVA Mode, the primary O₂ tank stores O₂ at 3,000 psia and provides makeup O₂ for replacing metabolically-consumed O₂ and ullage O₂ vented by the RCA unit. It also replaces the small amount of gas that nominally leaks from the suit or PLSS.

The primary pressure regulator steps the O₂ pressure down to the pressure required by the suit (4.3 psid) in nominal EVA Mode. This regulator performs as a variable pressure regulator, an isolation valve, and a check valve at different times because of the various functions it provides in the different PLSS modes of operation.

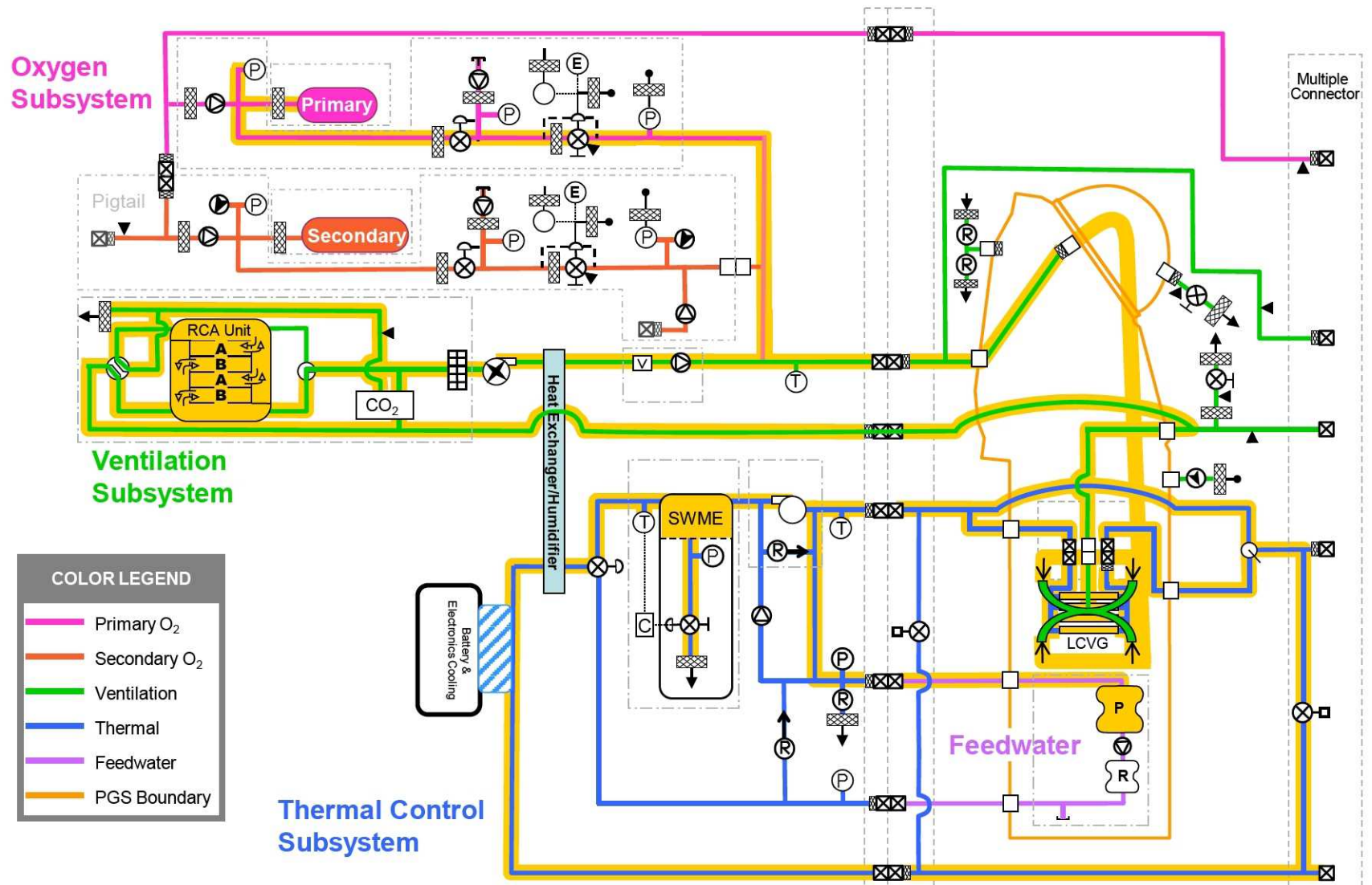

Figure 7. Nominal EVA flow paths. In the nominal EVA Mode, the PLSS performs autonomously to provide CM life support functions. The PLSS will rely on a low-pressure ambient environment for the SWME and RCA technologies to function.

The fan provides a ventilation flow rate of approximately 4 actual cubic feet per minute (acfm) throughout the ventilation loop. This flow rate provides washout of CO₂ and humidity within the helmet and it is also a driver for sizing the RCA unit. A change in flow rate could drive changes in the size of the amine beds within the RCA.

The RCA contains multiple amine beds that alternate between adsorbing and desorbing CO₂ and H₂O vapor from the ventilation stream. A valve within the RCA exposes one set of beds to the ventilation stream (adsorbing beds) and the other beds to vacuum (desorbing beds). Every 2 to 3 minutes, the valve changes its position and alternates which beds are exposed to vacuum and which are exposed to the ventilation stream. The H₂O heat exchanger cools the ventilation flow by transferring ventilation loop heat to the thermal subsystem. The heat exchanger removes heat that may have been added to the ventilation stream by the CM, the fan, the RCA (minimal), and the exterior environment.

In the nominal EVA Mode, the thermal subsystem provides the cooling function to maintain appropriate thermal conditions for the CM and PLSS equipment. The SWME provides the cooling function by evaporating H₂O that passes through a membrane, which is then vented to the ambient environment. The SWME can maintain the H₂O at a constant low temperature. A temperature control valve (TCV) is used to bypass the cold H₂O around the LCVG to keep the CM comfortable in cold environments when metabolic activity is low. The feedwater tanks provide makeup H₂O to replace H₂O evaporated in the SWME.

The pump circulates 200 pound-mass per hour (lbm/hr) of H₂O through the thermal subsystem H₂O loop during the nominal EVA Mode. This flow rate removes the appropriate heat load from the CM at high metabolic rates in a hot lunar environment, assuming the water temperature is conditioned to between 50 and 59 degrees Fahrenheit (°F). The flow passes through the electronics cold plate to remove waste heat from the PLSS battery and electronic equipment. The H₂O also flows through heat exchanger to remove waste ventilation loop heat. During nominal EVA Mode, the flow loop is completed because a closed when mated valve defaults to the OPEN position when the umbilical is not connected.

The CM controls the H₂O flow rate entering the LCVG by adjusting the TCV, and therefore, has direct control of his/her comfort level. The encoder is a candidate for removal since it may or may not be needed to control the SWME set point temperature. Further study is required. Model simulations for thermal conditions including the cold thermal environments at low metabolic rates do not show the need for a heater in the thermal subsystem.

In nominal EVA Mode, the pump maintains constant H₂O flow 200 (lbm/hr) through the H₂O Loop. The relief valve prevents the vehicle pump from being dead-headed. Performance analysis of the baseline PLSS schematic is currently in work.

The feedwater tanks are located inside the pressurized suit volume. Suit pressure pushes against these bladder tanks to force makeup H₂O into the H₂O loop when loop pressures dip due to SWME H₂O loss. The relief valve and check valve prevent the reserve feedwater tank from being used until the primary tank is empty. After the relief valve has cracked open, due to low pressure in the H₂O loop, reserve feedwater tank provides makeup H₂O to support a minimum of 30 minutes of cooling by the SWME. Activation of the relief valve prompts a warning to be sent to the CM to indicate that cooling H₂O is running low. The PLSS recharge mode three-way solenoid valve is always in the SWME to Heat Exchanger flow position during nominal EVA Mode. The solenoid valve is normally not powered by the PLSS batteries, but uses umbilical-based power. This reduces the PLSS battery power requirement.

B. Umbilical – No Recharge Mode

In the Umbilical – No Recharge Mode, the umbilical provides O₂ and cooling H₂O to the CM, but neither the O₂ tanks nor the feedwater tanks are refilled. Figure 8 shows the fluid lines that are active while in this mode. Data and communications are also provided through the umbilical while in this mode.

The O₂ subsystem is inactive in the Umbilical – No Recharge Mode. The umbilical O₂ maintains suit pressure high enough to prevent the pressure regulators from flowing O₂. The primary and secondary pressure regulators function as check valves in this mode to prevent bleed-down of O₂ from the ventilation subsystem if either the primary or secondary O₂ tank leaks down to vacuum.

The flow of O₂ enters from the umbilical and is routed to the helmet. Flow is picked up by the LCVG and routed back out to the umbilical. No other portion of the ventilation loop functions in this mode.

The cooling H₂O enters from the umbilical and the assumption is that it enters at a temperature between 50 and 59 °F. By adjusting the TCV, the CM controls how much cooling H₂O flows through the LCVG and how much bypasses around the LCVG. This valve allows variable flow to the LCVG ranging from full flow to zero flow. The encoder does not function in this mode, even though it is on the same shaft as the TCV.

Because the pump is a positive displacement pump, H₂O may not flow through it when it is off (it is normally off during all umbilical modes). Flow bypasses the pump through a check valve and routes to a flow control valve, which is in the SWME to Heat Exchanger flow position during Umbilical – No Recharge Mode. The H₂O then flows through a cold plate to cool electronics that may be powered on. The H₂O is then routed back to the umbilical.

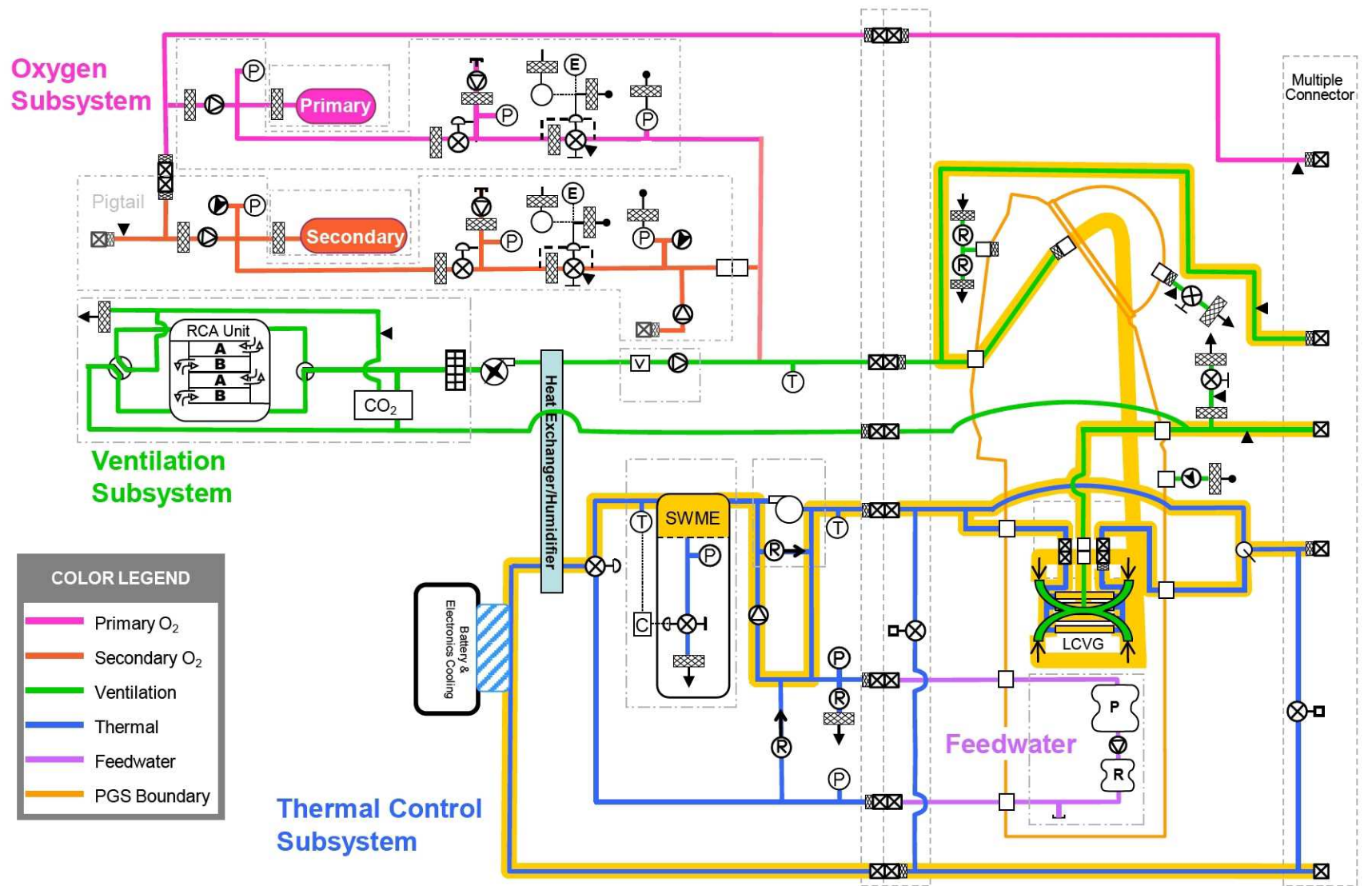

Figure 8. Umbilical without recharge mode flow paths. *In the umbilical (no recharge mode), the umbilical provides O₂ and cooling H₂O to the CM, but neither the O₂ tanks nor the feedwater tanks are refilled.*

C. Umbilical with Recharge Mode

The Umbilical with Recharge Mode accomplishes refilling the O₂ and feedwater tanks during suited or unsuited conditions. Figure 9 shows the active fluid lines in this mode.

During a suited condition, high-pressure O₂ refills the O₂ tanks and the ventilation subsystem provides life support to the suited CM. Cooling H₂O to refill the feedwater tanks is provided by the umbilical. The pump and the SWME are not functioning in this mode.

The O₂ tanks are pressurized to 3,000 psia with O₂ flowing through the high-pressure umbilical line. An orifice restricts the flow of the 3,000 psia O₂, which enters from the umbilical, to reduce the risk of fire caused by adiabatic compression or particle impact. Pressure sensors are monitored to determine when the tanks are fully pressurized.

During a suited condition Recharge Mode, the ventilation subsystem is functioning nominally (as in the EVA Mode) and the RCA is assumed to be vented to vacuum. During an unsuited condition, the ventilation subsystem is in an off condition because no life support functions are required.

A solenoid valve, not normally powered by the PLSS battery, is set to Reserve Bladder to Heat Exchanger position in this mode, whereas it was set to SWME to Heat Exchanger position in the Umbilical – No Recharge Mode. In the Reserve Bladder to Heat Exchanger position, H₂O flow is directed through the primary and reserve feedwater tanks, bypassing the pump and the SWME. This routing allows the feedwater tanks to refill. A pressure sensor indicates when the tanks are full. The H₂O reenters the normal cooling H₂O loop at the solenoid valve.

During suited Recharge Mode, the CM adjusts the TCV to provide thermal comfort. During unsuited Recharge Mode, the TCV is set to the full LCVG bypass position because the LCVG will probably not be connected to the suit. If an LCVG jumper is installed during unsuited recharge, the TCV can be in any position.

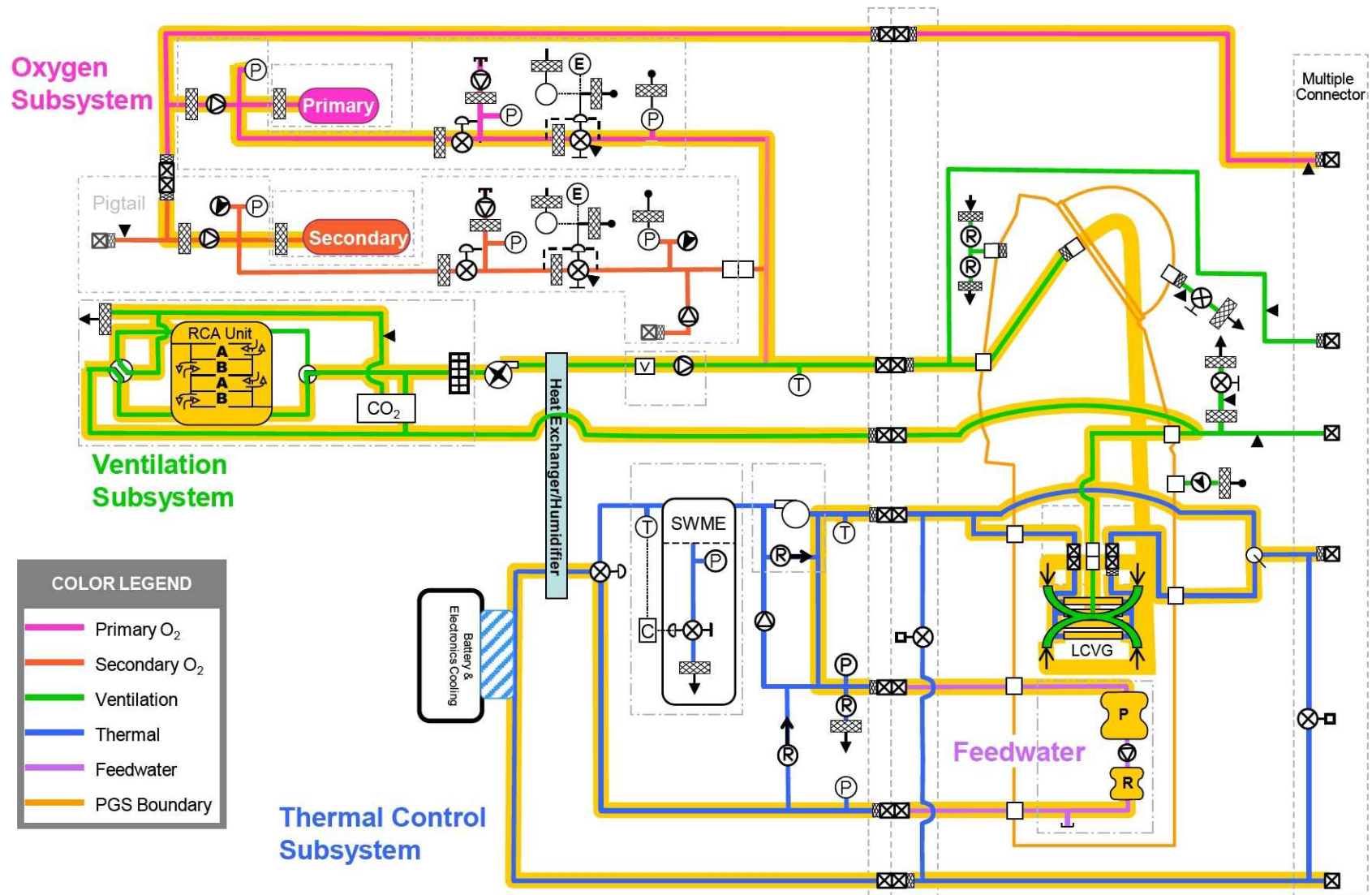

Figure 9. Umbilical with recharge mode flow paths. *The umbilical with recharge mode accomplishes refilling the O₂ and feedwater tanks during suited or unsuited conditions. Cooling water used to refill the feedwater tanks is provided by the umbilical, and the pump and the SWME are not functioning.*

D. DCS Treatment Mode

The CM can select DCS Treatment Mode with two options, the EVA option, shown in Fig. 10, and the umbilical option shown in Fig. 11. The DCS Treatment Mode EVA flow paths are nearly identical to the nominal EVA Mode. The DCS Treatment Mode umbilical option is nearly identical to the Umbilical Without Recharge Mode.

In the O₂ subsystem, the DCS Treatment Mode EVA option has only one difference compared to the nominal EVA Mode. In DCS Treatment Mode, the primary O₂ pressure regulator controls to a pressure supporting DCS treatment, an approximate value of 8 psid (above ambient pressure), as in the EMUs of both the ISS and Shuttle programs. In the DCS Treatment Mode umbilical option, the O₂ subsystem is inactive.

The ventilation flow paths in the DCS Treatment Mode umbilical option are identical to the flow paths in the Umbilical – No Recharge Mode. The umbilical will provide O₂ at the higher DCS treatment pressures while in this mode. The suit pressure relief valve set point will be based on the highest DCS treatment pressure so that it does not relieve pressure in this mode.

The DCS Treatment Mode EVA option flow paths for the thermal subsystem are identical to the flow paths of the nominal EVA Mode. Because the H₂O loop pressure is set by the suit pressure applying force upon the feedwater bladder tanks, the pressure of the H₂O loop will be nearly equal to the DCS treatment pressure maintained in the suit. The thermal subsystem relief valve set point will be based on the highest DCS treatment pressure so that it does not relieve pressure in this mode. Because LCVG loop pressure is set by the suit pressure, the difference between the H₂O loop and the ventilation loop is minimal. This minimizes leak rate if the LCVG water tubes are ever breached.

The DCS Treatment Mode umbilical option flow paths are identical to the Umbilical – No Recharge Mode flow paths. H₂O loop pressure will be set by the H₂O pressure delivered by the umbilical.

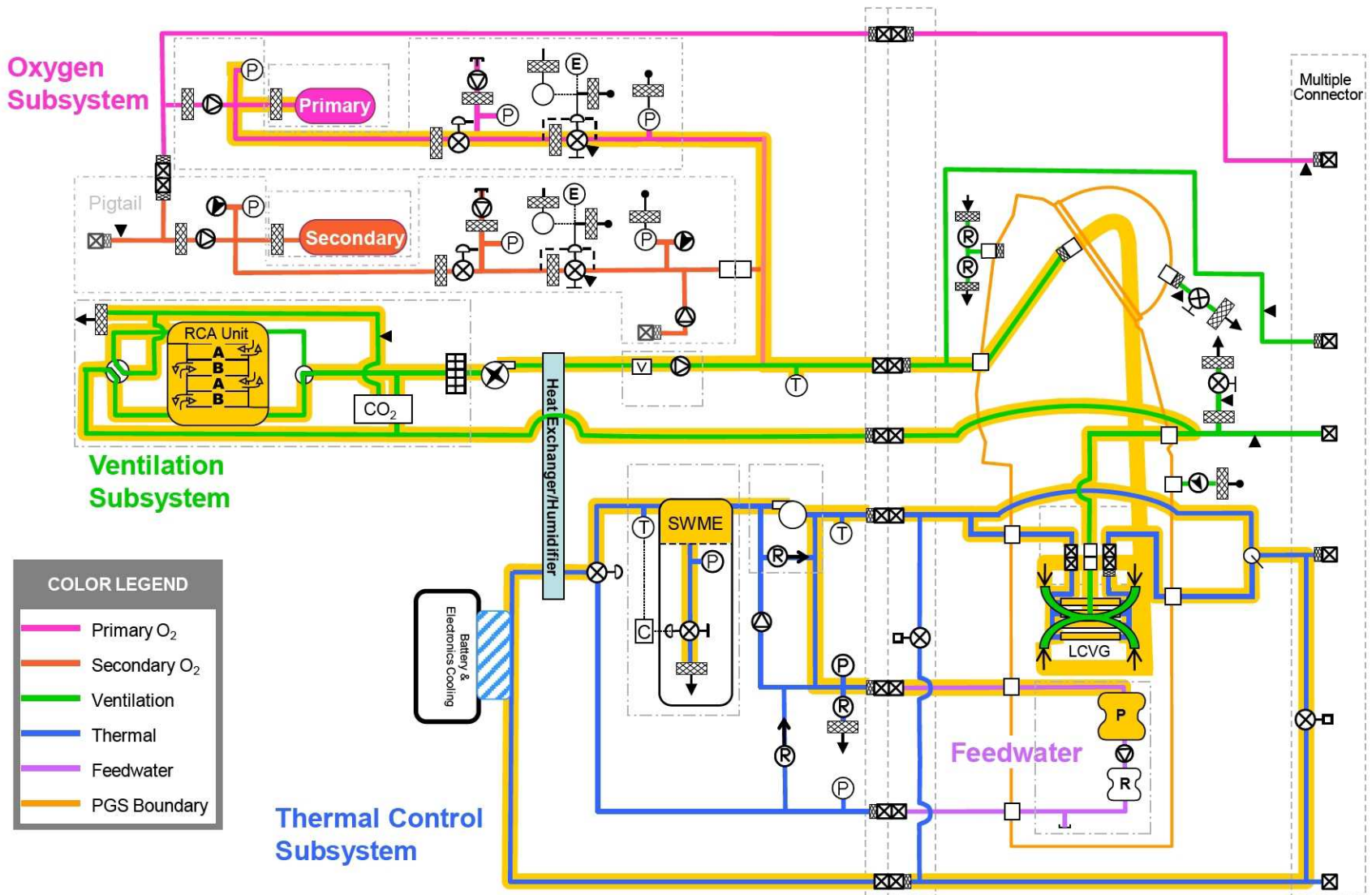

Figure 10. DCS treatment mode EVA flow paths. The CM can select DCS Treatment Mode with two options, the EVA option and the umbilical option. The DCS Treatment Mode EVA option flow paths are nearly identical to the nominal EVA Mode.

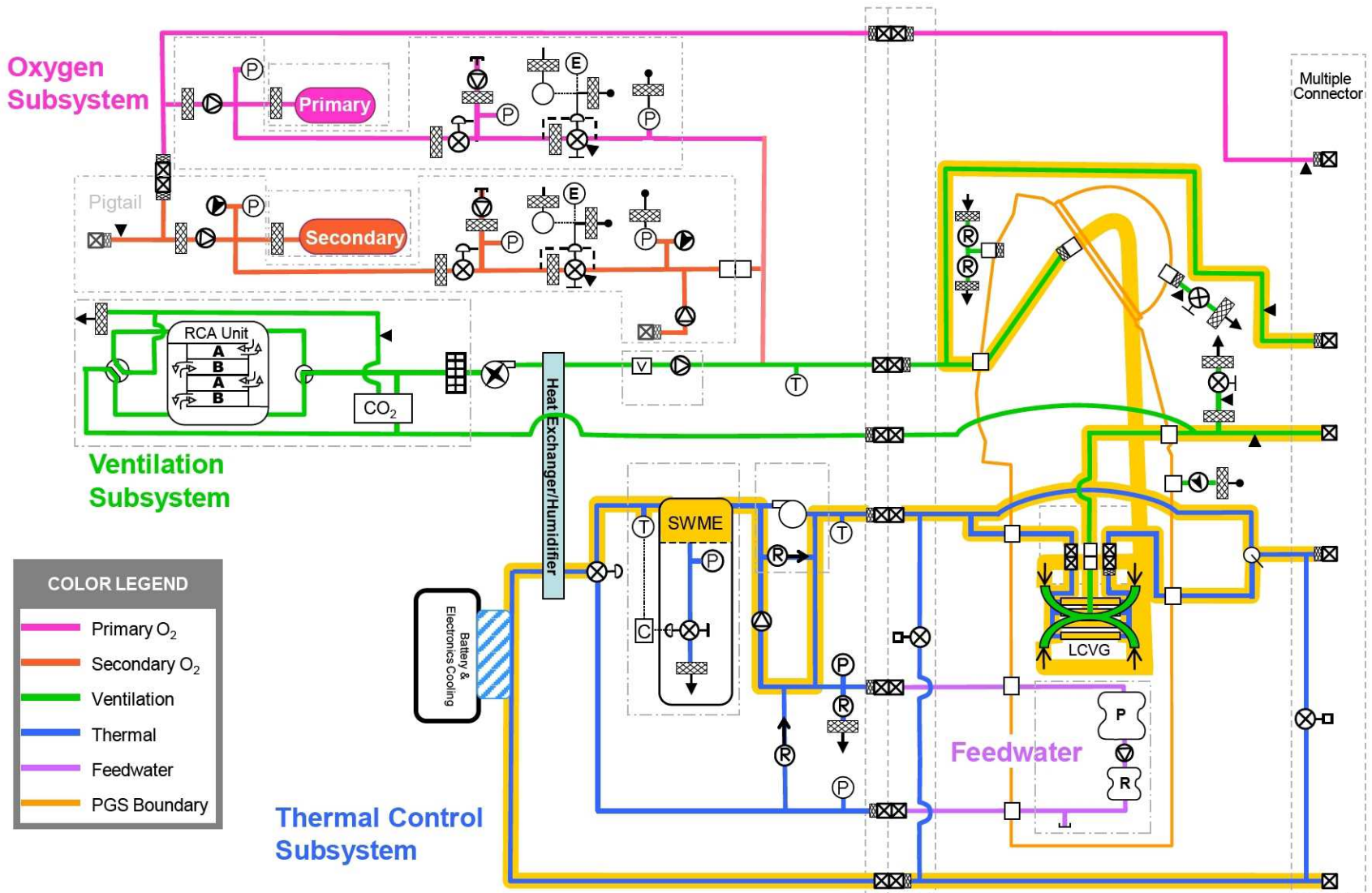

Figure 11. DCS treatment mode umbilical flow paths. The CM can select DCS Treatment Mode with two options, the EVA option and the umbilical option. The DCS Treatment Mode umbilical option is nearly identical to the umbilical (no recharge mode).

E. Buddy Mode

The Buddy Mode is proposed to cover the situation in which one CM's PLSS encounters a failure, such as a loss of power, during an EVA. The PLSS that did not encounter failure (i.e., the functional PLSS) supplies the O₂ and cooling H₂O to the CM with the failed PLSS (i.e., the disabled PLSS) through the Buddy umbilical. Figure 12, which shows active fluid lines for this mode. To engage the Buddy Mode, CMs set the mode selector for the suit with the functional PLSS to Buddy and attach the Buddy umbilical to both suits.

The Space Shuttle and ISS EMUs do not include a Buddy capability. Differences in the mission profiles account for the need of a Buddy capability in the PLSS. The EVA CMs will travel much farther from the airlock during lunar EVAs, as compared to ISS and Shuttle EVA excursions. Generally, the increased travel results in more time to retreat back to the airlock in case of failure. Farther travel also results in additional O₂ required to allow the CMs to return to the airlock safely. The Buddy Mode provides the emergency cooling capability, which addresses the concerns associated with potential hot lunar environments, as well as the high, metabolic rate activity levels connected with gravity environments. A Buddy system providing O₂ and cooling H₂O results in the most economical (in terms of mass and volume) emergency PLSS system design for lunar and Mars EVA support.⁹

The flow paths of the O₂ subsystem in the functional PLSS during Buddy Mode are very similar to the flows in the nominal EVA Mode, except that additional flow supports both suits. If the primary O₂ tank runs low while in the Buddy Mode, the secondary O₂ tank will begin providing O₂. The O₂ system of the disabled PLSS is inactive during the Buddy Mode.

The ventilation subsystem flow paths in the functional PLSS are similar to the flow paths in the nominal EVA Mode, except that the O₂ flow is split just upstream of the ventilation flow suit inlet. A portion of the flow travels to the Buddy umbilical from this split location. The O₂ then flows to the disabled PLSS through the O₂ supply line used in the Umbilical Mode. The O₂ then enters the disabled PLSS helmet and returns to the functional PLSS via an umbilical.

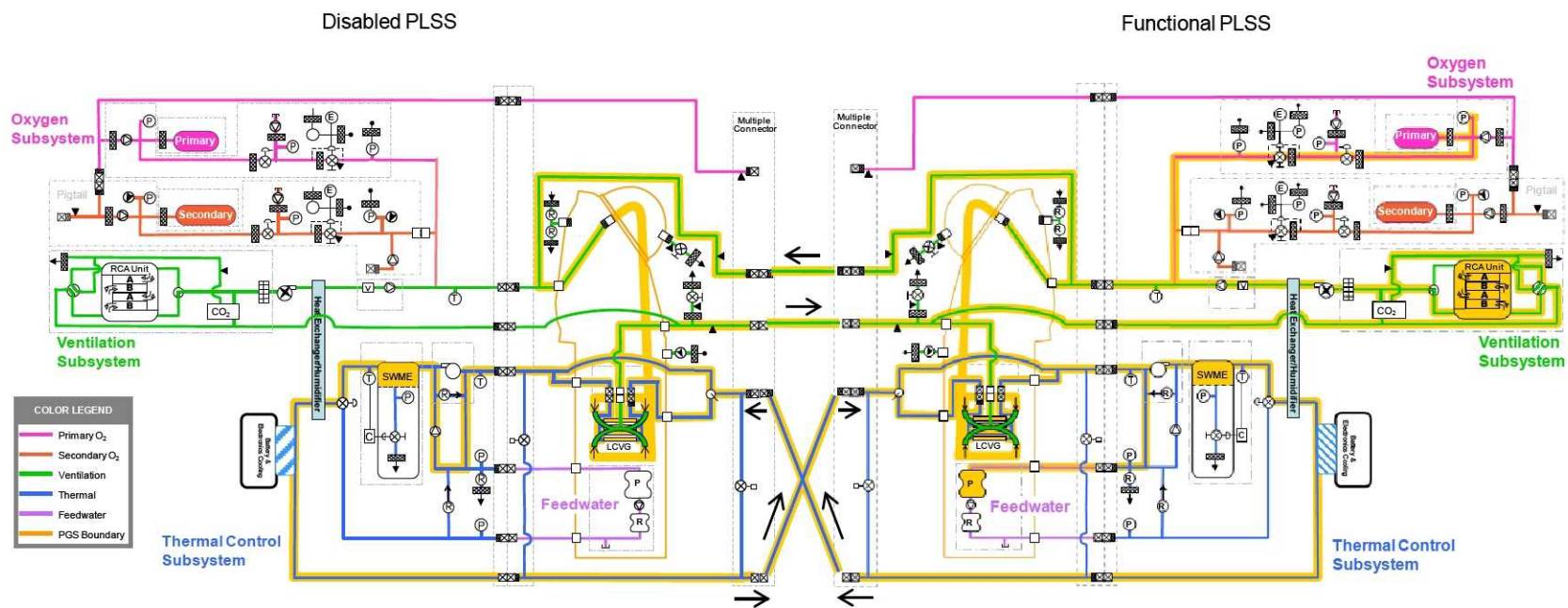

Figure 12. Buddy mode flow paths. This is a mode to cover the situation in which one CM's PLSS encounters a failure, such as a loss of power, during an EVA. The PLSS that did not encounter failure (functional PLSS) supplies the O₂ and cooling H₂O to the CM with the failed PLSS (disabled PLSS) through the Buddy umbilical.

Orifices in the functional PLSS are located in series with the orifices of the disabled PLSS in this configuration, limiting the O₂ flow to the disabled PLSS in the case of a sizeable breach within the failed suit. This prevents the potential compromise of the functional PLSS in such a situation. In Buddy Mode, the fan must provide twice the flow capacity and the RCA unit removes CO₂ and humidity from both CMs.

The flow paths for the functional PLSS in Buddy Mode are similar to the flow paths in the nominal EVA Mode. The cool H₂O exits the functional PLSS via an umbilical. The H₂O coming from the disabled PLSS reenters the functional PLSS at another umbilical. The CM adjusts the TCV of the functional PLSS to control the amount of cooling H₂O sent to his or her LCVG. One possible control scheme is to use a temperature sensor on the cooling H₂O line near the outlet of the SWME and control this temperature to 50 °F during Buddy Mode by adjusting primary pressure regulator automatically. The flow paths and component functions of the thermal subsystem in the disabled PLSS are exactly the same as those in the Umbilical – No Recharge Mode.

F. Secondary O₂ Modes

The secondary O₂ modes are autonomous emergency modes where the PLSS encounters a failure and cannot rely on the Buddy Mode for whatever reason. There are three options within the secondary O₂ modes: the helmet purge option, the suit purge option, and the operational option. When fresh O₂ is not being delivered to the helmet, the CM selects between the helmet and the suit purge options by opening either the helmet purge valve or the suit purge valve depending on the EVA mission scenario and/or the nature of the failure or condition that triggers the need for using secondary O₂. The secondary O₂ operational option is automatically initiated if primary O₂ is not being delivered to the ventilation system when all other PLSS operations are functioning nominally. The secondary O₂ modes assume that low-pressure and vacuum ambient conditions exist.

The helmet purge option, shown in Fig. 13, flows O₂ through the helmet, which then exits to the ambient environment through the helmet purge valve. This option is used during a failure within the ventilation loop (e.g., RCA failure, fan failure, battery failure, etc.) and provides no cooling to the CM's body, just minimal evaporative cooling to the head. The assumption is that the emergency duration capability in this mode is similar to the Space Shuttle and ISS EMU helmet purge duration of approximately 45 minutes.

The suit purge option, shown in Fig 14, flows O₂ through the helmet, over the CM's body, through the LCVG ventilation tubes, and then through the helmet purge valve to the ambient environment. This option is used when PLSS cooling is compromised and provides some evaporative cooling to the CM's head and body, but the flow rate of the ventilation stream limits this effect. The assumption is that the emergency duration capability in this mode is similar to the Space Shuttle and ISS EMU Display and Controls Module (DCM) purge duration of approximately 30 minutes.

The operational option, shown in Fig. 15, assumes that the PLSS is fully operational, with the exception that either the primary O₂ runs out or component failure prevents primary O₂ delivery. This mode uses considerably less O₂ than either of the purge modes listed above because the ventilation subsystem is recycling O₂. This potentially allows for significantly longer emergency durations. Battery capacity and cooling H₂O capacity drive the emergency duration capability in this mode. The ambient thermal environment effects need to undergo evaluation to determine the emergency duration capability of the operational option.

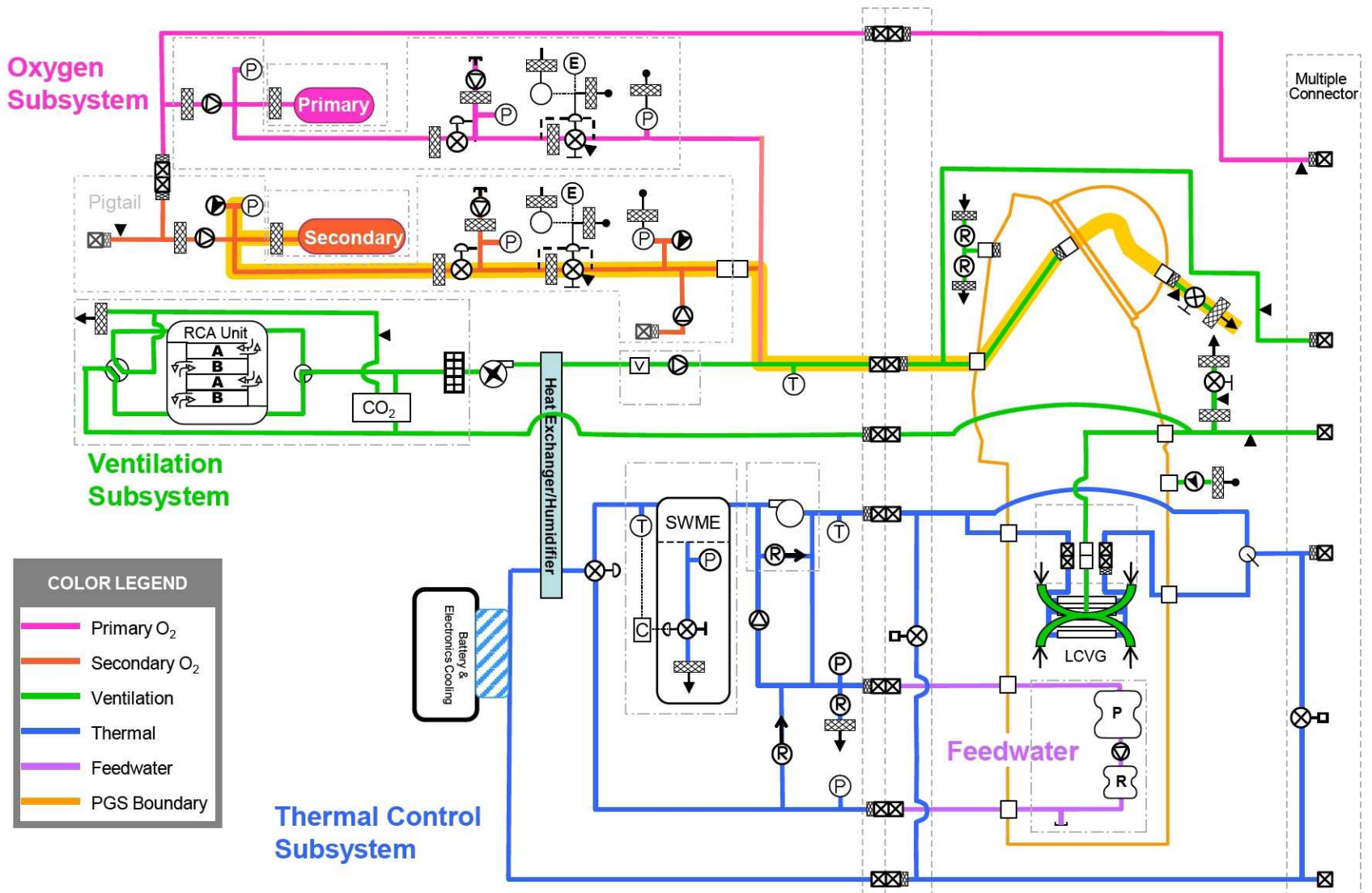

Figure 13. Secondary O₂ helmet purge flow paths. *The secondary O₂ modes are autonomous emergency modes where the PLSS encounters a failure and cannot rely on the Buddy Mode for whatever reason. There are three options within the secondary O₂ modes: the helmet purge option, the suit purge option, and the operational option. The secondary O₂ modes assume that low-pressure and vacuum ambient conditions exist. This figure shows the helmet purge option.*

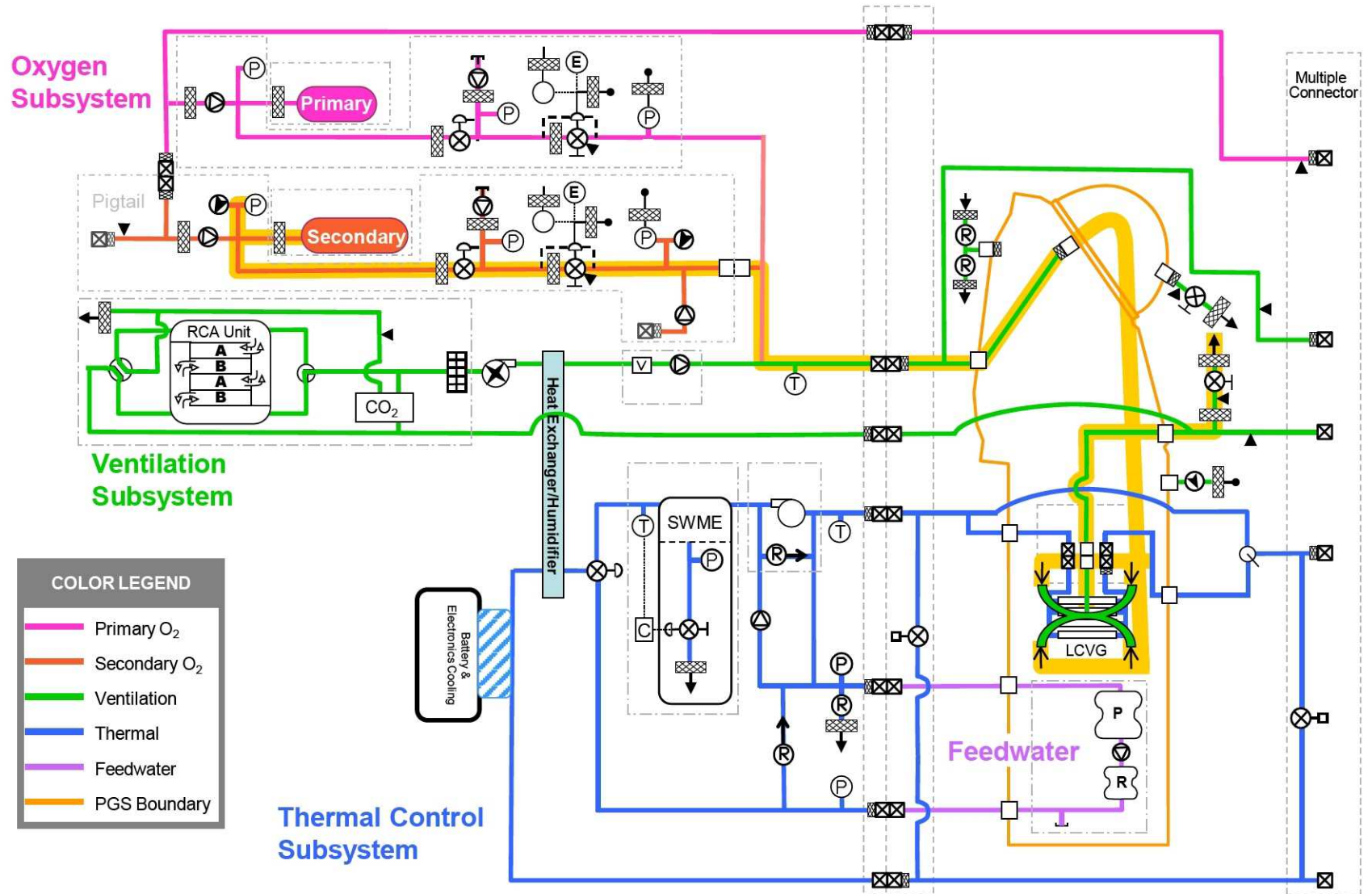

Figure 14. Secondary O₂ suit purge flow paths. The secondary O₂ modes are autonomous emergency modes where the PLSS encounters a failure and cannot rely on the Buddy Mode for whatever reason. There are three options within the secondary O₂ modes: the helmet purge option, the suit purge option, and the operational option. The secondary O₂ modes assume that low-pressure and vacuum ambient conditions exist. This figure shows the suit purge option.

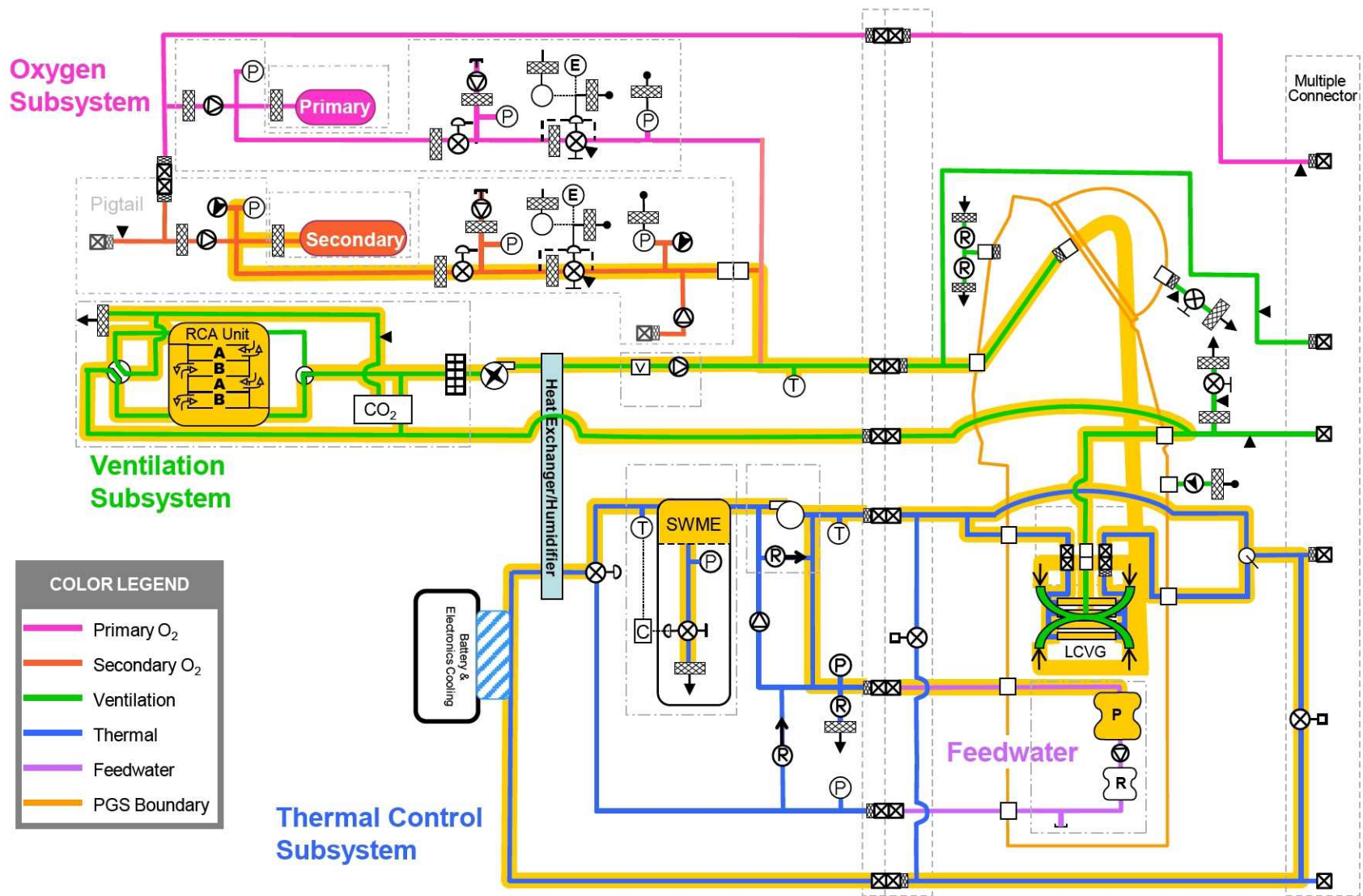

Figure 15. Secondary O₂ operational option flow paths. The secondary O₂ modes are autonomous emergency modes where the PLSS encounters a failure and cannot rely on the Buddy Mode for whatever reason. There are three options within the secondary O₂ modes: the helmet purge option, the suit purge option, and the operational option. The secondary O₂ modes assume that low-pressure and vacuum ambient conditions exist. This figure shows the operational option.

In the secondary O₂ modes, the secondary O₂ pressure regulator detects low pressure in the ventilation loop. This causes the pressure regulator to open and provide O₂ at approximately 3.6 psid to the ventilation subsystem. The amount of O₂ provided depends on the quantity of O₂ lost by the ventilation loop.

To activate the secondary O₂ helmet purge mode, the CM opens the helmet purge valve. This causes O₂ to escape the suit at a rate that depletes the secondary O₂ tank in approximately 45 minutes (similar to Space Shuttle and ISS EMU helmet purge operations). To activate the secondary O₂ suit purge mode, the CM opens the suit purge valve. This causes O₂ to escape the suit at a rate that depletes the secondary O₂ tank in approximately 30 minutes (similar to Space Shuttle and ISS EMU DCM purge operations).

Activation of the secondary O₂ operational mode requires no action from the ventilation subsystem. If the primary O₂ system fails, the ventilation loop will drop in pressure and the secondary O₂ pressure regulator will activate. Performance modeling results should show whether there are any detrimental impacts due to operating the ventilation loop at the lower pressure maintained by the secondary pressure regulator (3.6 psid). One possible outcome of the performance modeling may be to adjust the pressures or other operating conditions maintained in this mode. The ventilation subsystem flow paths during this operational option are the same as the flow paths of the nominal EVA Mode.

The assumption is that the thermal subsystem is inactive during the helmet and suit purge modes. If power is still available and the thermal subsystem has not failed, it is possible for the thermal subsystem to operate normally while in the helmet and suit purge modes with flow paths identical to the nominal EVA Mode flow paths. In the secondary O₂ operational mode, thermal subsystem flow paths are identical to nominal EVA Mode flow paths.

G. PLSS Removed Umbilical Mode

The current operational concept for returning from a lunar mission includes the ability to doff the PLSS and leave it on the lunar surface before launching to return to Earth. A possibility exists for the doffing procedure to take place at vacuum conditions. This capability requires the PLSS Removed Umbilical Mode.

The PLSS schematic includes quick disconnects, shown in Fig. 16, allow for removal of the PLSS when the suited CM is relying on the umbilical for life support functions. A closed-when-mated valve at the umbilical closes when the umbilical is connected. The closed-when-mated valve between the suit and the PLSS opens when the PLSS is removed allowing for cooling H₂O to return to the umbilical without using additional plumbing or valves.

The following steps detail the operational concept for removing the PLSS:

1. CM attaches umbilical and enables the Umbilical – No Recharge Mode
2. CM powers off the PLSS
3. CM disconnects and removes the PLSS

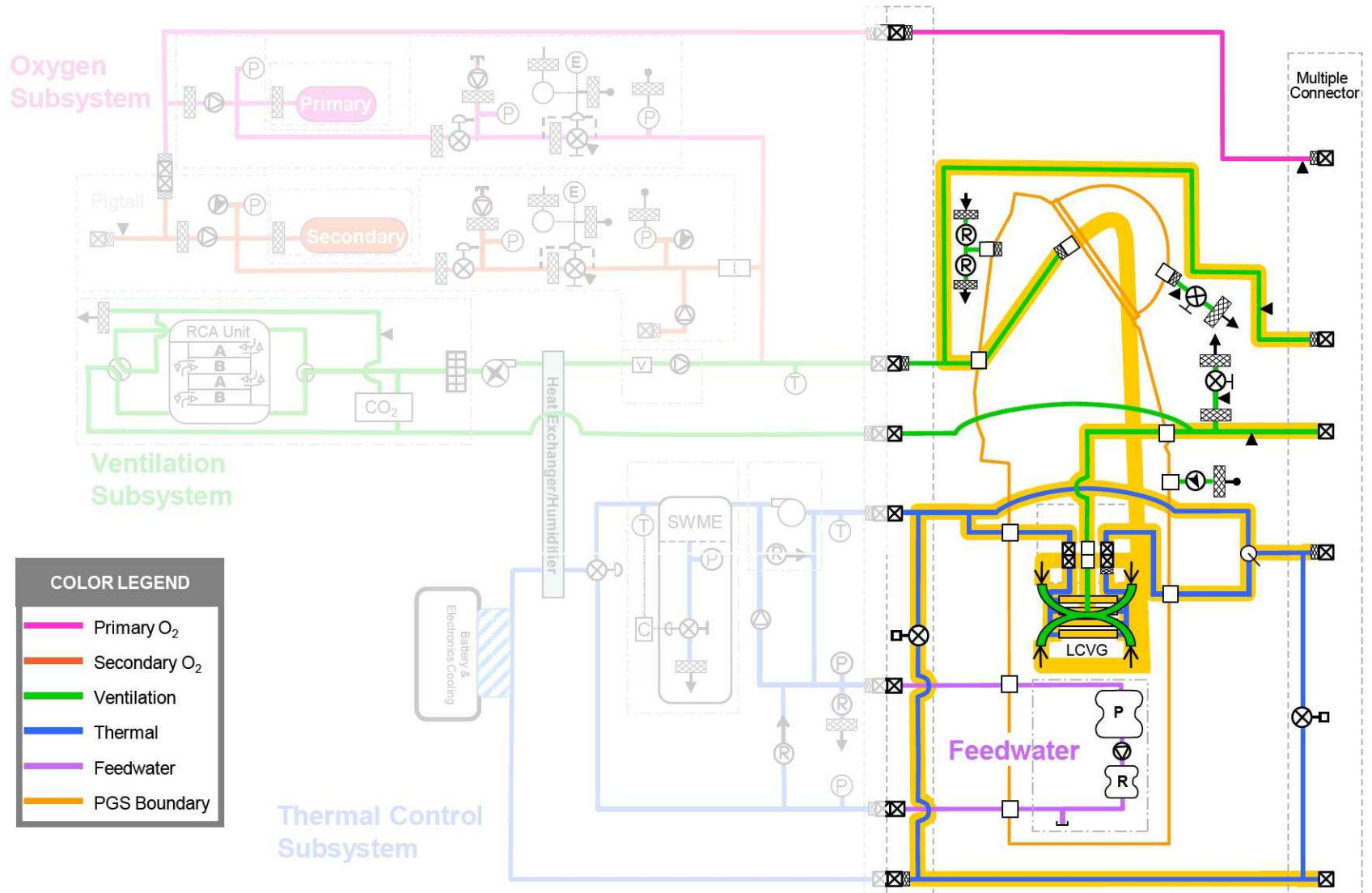

Figure 16. PLSS removed umbilical mode flow paths. The current operational concept for returning from a lunar mission includes the ability to doff the PLSS and leave it on the lunar surface before launching to return to earth. A possibility exists for the doffing procedure to take place at vacuum conditions. The PLSS schematic includes quick disconnects to allow for removal of the PLSS when the suited CM is relying on the umbilical for life support functions. The direction of the cooling H₂O flow through the LCVG reverses, as compared to the LCVG flow in the modes discussed previously.

VIII. Comparison to Space Shuttle/ISS and Apollo PLSS and Technology Options

The baseline PLSS schematic uses fewer consumables and requires less EVA preparation time than the Space Shuttle/ISS and Apollo PLSS. Fewer consumables and less preparation time is driven by the significant increase in the number of required EVAs for the baseline PLSS. Figure 17 shows the number of EVAs and related masses for the unique PLSSs for each of the different programs.

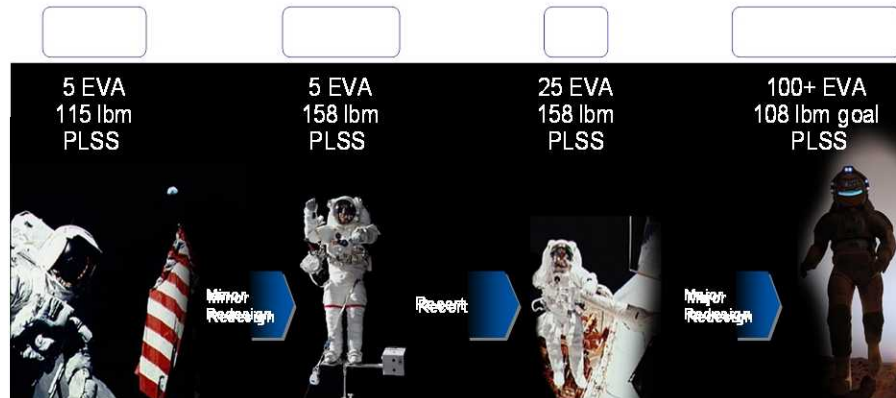

Figure 17. Number of EVA comparison. *The numbers of EVAs has significantly increased to support future missions.*

Table 1, shows the detailed comparisons of the significant PLSS design differences between the Apollo, Space Shuttle/ISS, and PLSS designs. Masses are shown for the Apollo, Space Shuttle, and ISS PLSS. Due to various assumptions that can be made for determining what is and what is not to be included in PLSS mass, these mass values are considered approximate and may differ from PLSS mass values quoted in other references.

One of the key differences between the baseline PLSS schematic and the Space Shuttle/ISS and Apollo PLSS is the technology used for cooling the CM and PLSS equipment. The Space Shuttle/ISS and Apollo employed a sublimator that exposes an ice layer to the vacuum of space, which sublimates and thus provides the cooling required by the CM and PLSS equipment. This technology requires a very low pressure for the sublimation process to occur. The average atmospheric pressure on Mars is high enough to suppress this sublimation process. To be more compatible with potential Mars PLSS requirements, the baseline PLSS includes a SWME, which provides cooling by evaporating H₂O. This technology is not significantly impaired by the pressure of the Martian atmosphere.

Additionally, the Space Shuttle/ISS and Apollo PLSS made use of a condensing heat exchanger incorporated into the sublimator. This heat exchanger condensed the humidity generated by the CM within the ventilation loop. Condensed H₂O from the ventilation loop separated from the ventilation stream and recycled back to the sublimator so that there was practically no H₂O consumption for this function. An approximately equal amount of recycled condensation replaced the H₂O lost to vacuum by the sublimator as it removed the heat of condensation in the condensing heat exchanger. Therefore, the feedwater tanks that supplied H₂O to the sublimator needed practically no additional feedwater storage to support condensation for humidity removal.

The technology used for CO₂ and humidity removal is the second major difference between the baseline PLSS schematic and the Space Shuttle/ISS and Apollo PLSS. The Space Shuttle/ISS PLSS and Apollo PLSS used a lithium hydroxide (LiOH) canister or metal oxide (Metox) to remove CO₂. Each LiOH canister was used for one EVA and needed to be replaced before the next EVA. This resulted in significant consumable requirements for missions with numerous EVAs. The Metox unit is a relatively heavy canister that is regenerated after each EVA and requires significant power and heating resources from the vehicle. The regeneration time for the Metox unit is on the order of 14 hours total with approximately 10 hours to recharge the unit and 4 hours to cool the unit.

Table 1. Historical PLSS comparison. *A functional comparison of the Apollo PLSS, Shuttle/ISS EMU, and the baseline PLSS.*

Subsystem	Area of Comparison	Apollo ¹⁰	Shuttle/ISS EMU ^{11, 12}	Baseline PLSS
Overall	Mass	~115 lbm dry	~158 lbm LiOH dry	Current ~ 128 lbm Goal wet < ~108 lbm
	Prebreathe	No prebreathe	Lengthy prebreathe	Less prebreathe than EMU
	Doffable in a vacuum	Yes	No	Yes
	Feedwater backpressure	15 psid O ₂ regulator	15 psid O ₂ regulator	Uses suit pressure
	Buddy capability - cooling water	Yes	No	Yes
	Buddy capability - ventilation	No	No	Yes
O₂	Primary O ₂	1420 psia	900 psia	3000 psia
	Secondary O ₂	5800 psia	6000 psia	3000 psia
	Primary O ₂ mass	1.8 lbm	1.2 lbm	1.6 lbm
	Secondary O ₂ mass	5.8 lbm	2.6 lbm	2.6 lbm
Ventilation	Uses LiOH canister	Yes	Yes	No
	Uses Metox-regnerable	No	Yes	No
	CO ₂ removal unit regenerates during EVA	No	No	Yes
	CO ₂ removal unit cooling required	Yes	Yes	No
	CO ₂ control duration	8-hour EVA	8-hour EVA	Continuous
Thermal Control	Heat Exchanger	Sublimator	Sublimator	SWME
	Water	De-ionized water	De-ionized water	Potable water
	Pump	Centrifugal pump	Centrifugal pump	Positive displacement pump

Instead of using LiOH or Metox the PLSS schematic includes an RCA unit for CO₂ and humidity removal. The RCA contains multiple amine beds that alternate between adsorbing CO₂ and H₂O and desorbing CO₂ and H₂O to the vacuum of space. The adsorbing beds generate heat while the desorbing beds cool. The adsorbing beds are designed to allow significant heat exchange with the desorbing beds, resulting in only a small amount of excess heat entering the ventilation loop and the PLSS. The key advantages of this unit are that it requires minimal maintenance, it can continuously regenerate, it does not need recharging or replacement after each EVA, and it requires practically no cooling from the PLSS cooling unit.

IX. Conclusions and Recommendations

This document presents descriptions and discussion of a baseline PLSS schematic proposed for future exploration activities. A comparison to Shuttle and Apollo PLSS designs highlights several potential advantages with the proposed baseline PLSS. Many of the proposed operations and functions of the major PLSS components are being evaluated in a separate effort to develop and exercise transient performance models of the baseline PLSS⁸. Future evaluations may reveal potential improvements to the baseline PLSS schematic. For example, a recent study has indicated that the humidifier may be eliminated from the schematic¹³. The following investigations are currently planned to evaluate the baseline PLSS schematic:

- During normal EVA operations, the assumption is that the SWME back pressure regulating valve is set to a constant set point temperature. An evaluation of alternate control schemes is planned to optimize thermal performance of the PLSS thermal subsystem.
- Plans for integrated test planning activities are taking into consideration the identified uncertainties in the baseline PLSS modeling approaches. Also, integrated PLSS test configurations are to be evaluated to provide pre-test predictions and insight into performance differences between test results and flight conditions.
- Evaluate thermal comfort effects and transients related to component failure scenarios.
- Update PLSS performance modeling based on PLSS component technology development testing results.
- Evaluate combining the SWME with the ventilation heat exchanger.
- Perform an updated filter study that includes filtering strategies for various components throughout the PLSS.
- Evaluate the advantages and disadvantages of integrating an ejector into the secondary O2 capability.

ACKNOWLEDGMENTS

The authors would like to thank David Westheimer, EVA Technology Development Manager, and Gretchen Thomas, EVA Technology PLSS Lead, for their continued support of this work. The authors would also like to thank David Autry for his valuable assistance in developing PLSS schematics.

REFERENCES

- ¹Cooke, Doug, Associate Administrator, NASA Exploration Systems Mission Directorate, June 12, 2008
- ²Bailey, P. S., Ph.D, JSC-65443/CTSD-CX-0005, Rev. A, Constellation Space Suit System Portable Life Support System (PLSS) Schematic Selection Study, NASA Johnson Space Center, Houston, TX., January 2007
- ³Conger, B., Leavitt, G., Falconi, E., and Chullen, C., JSC 65563/CTSD-Cx-5117, Rev. A, Constellation Space Suit Element PLSS Baseline Schematics and Internal Interfaces, April 2008
- ⁴Autrey, D., Barnes, B., Conger, B., Leavitt, G., and Wells, J., JSC 65563/CTSD-Cx-5117, Rev. B, Constellation Space Suit Element PLSS Baseline Schematics and Internal Interfaces, September 2009
- ⁵Corte, Jeannie, designer of PLSS Schematic Tool, Chart 3 "Overview," December 2007.
- ⁶Connors, M. M., Eppler, D. B., and Morrow, D. G., NASA Technical Memorandum 108846, Interviews with Apollo Lunar Surface Astronauts in Support of Planning for EVA Systems Design, Sept. 1994.
- ⁷CxP 72208, Rev. A, Constellation Space Suit Element Requirements Document, June 10, 2008
- ⁸Thomas, G. A., Conger, B., Barnes, B., Navarro, M., "2009 PLSS Annual Review, Thermal/Hydraulic Analysis", NASA Johnson Space Center, Houston, TX., September 2009.
- ⁹Vonau, W. Jr., ESCG-4470-05-TEAN-DOC-0119, Analysis of Emergency Oxygen System, Engineering and Science Contract Group, Houston, TX., September 2005.

¹⁰CSM/LM Spacecraft Operational Data Book, SNA-8-D-027 (IV) Rev 2, Volume IV EMU Data Book Revision 2, Prepared by Systems Engineering Branch, Crew Systems Division, Engineering and Development Directorate, Manned Spacecraft Center, July 7, 1971.

¹¹Thomas, G. A., Packaging Factors for Portable Life Support Subsystems Based on Apollo and Shuttle Systems,” Houston: NASA Johnson Space Center, International Conference on Environmental Systems #932182, Houston, TX., July 1993.

¹²NASA Extravehicular Mobility Unit (EMU) LSS/SSA Data Book, Hamilton Sundstrand, Revision M, Contract NAS9-97150, September 2007.

¹³Barnes, B. G., ESCG-4470-10-TEAN-DOC-0002, Feasibility of Removing the Humidifier from the Baseline Portable Life Support System, Engineering and Science Contract Group, Houston, TX., February 2010.