

# Bulk Current Injection Testing of Close Proximity Cable Current Return, 1 kHz to 1 MHz

Arthur T. Bradley<sup>#1</sup>, William M. Lee<sup>#2</sup>, Vivek Singh<sup>#3</sup>, Brian Yavoich<sup>#4</sup>

NASA Langley Research Center

5 North Dryden, MS488, Hampton, VA 23681 USA

<sup>1</sup>arthur.t.bradley@nasa.gov

<sup>2</sup>wmlee@bsc.edu

<sup>3</sup>svivek@vt.edu

<sup>4</sup>brian.yavoich@fandm.edu

**Abstract**— This paper presents the results of an experiment examining the percentage of current that returns on adjacent wires or through a surrounding cable shield rather than through a shared conducting chassis. Simulation and measurement data are compared from 1 kHz – 1 MHz for seven common cable configurations. The phenomenon is important to understand, because minimizing the return current path is vital in developing systems with low radiated emissions.

## I. INTRODUCTION

When designing low-noise systems, minimizing the current loop area is critically important. Radiated emissions are directly proportional to current loop area both in the near and far-fields [1] [2]. Equations assume a low-impedance loop antenna structure excited by a circulating current.

*Near Field* ( $r < 48/f_{MHz}$ )

$$E_{nf\_loop\_max} \cong 6.28 \cdot 10^{-7} \left(\frac{1}{r^2}\right) f A_l I \quad (1)$$

$$H_{nf\_loop\_max} \cong 7.96 \cdot 10^{-2} \left(\frac{1}{r^3}\right) A_l I$$

*Far Field* ( $r > 48/f_{MHz}$ )

$$E_{ff\_loop\_max} \cong 1.316 \cdot 10^{-14} \left(\frac{1}{r}\right) f^2 A_l I \quad (2)$$

$$H_{ff\_loop\_max} \cong \frac{E_{ff\_loop\_max}}{Z_o}$$

Several simple cases are illustrated in Fig. 1. In the single-wire case, all of the current must return by the chassis – very undesirable since it will likely result in a large current loop area. By adding a dedicated return wire and/or surrounding shield, the return current will divide between the wire and/or shield, and the chassis. The percentage of this division is a topic examined in this paper. Finally, in the case of differential signalling, the amount of current that returns along the chassis is due only to imbalances in signal sources or load impedances – typically both are able to be controlled very well.

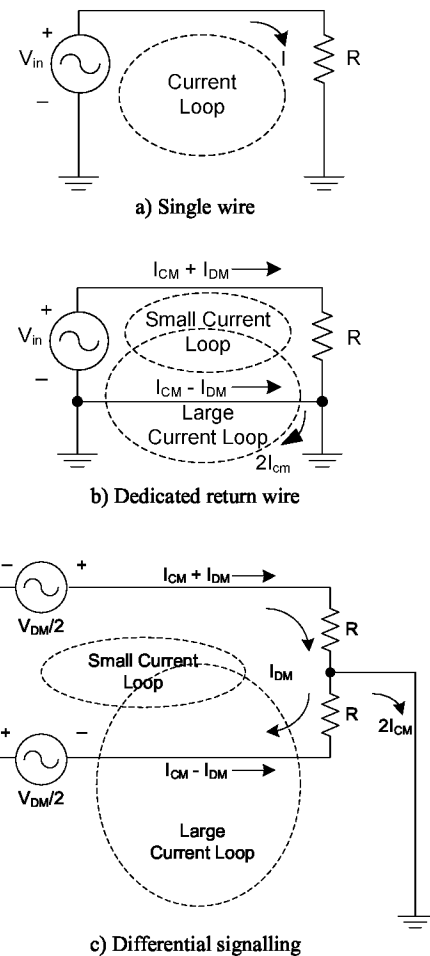

Fig. 1 Controlling signal return current

Minimizing current loop area implies controlling the return current path. The most obvious method of achieving this control is through the use of dedicated return conductors and subsystem isolation (a.k.a. single-reference grounding). If subsystem isolation is not maintained for power distribution, one or more ground loops will be formed (typically involving the chassis connection) as shown in Fig. 2.

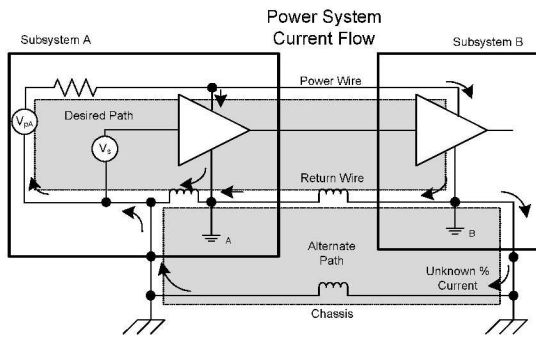

Fig. 2 Uncontrolled power return current

Fig. 3 (a) and (b) show lower noise system decoupled methods of power distribution for both non-isolated and isolated load cases. In both cases, the DC current returns on the dedicated wire routed adjacent to the outgoing power wire. This results in a very small current loop area.

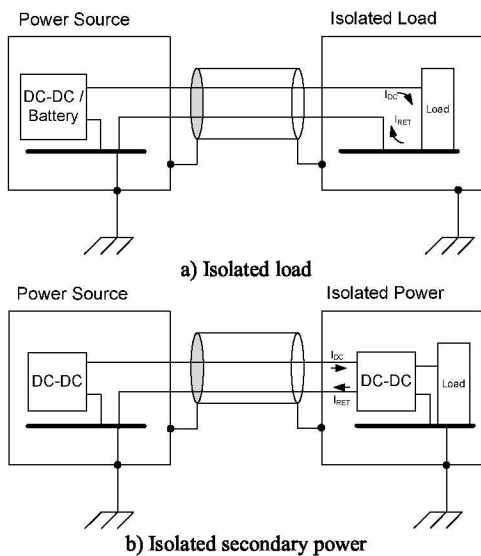

Fig. 3 Controlled power return current

Similarly, if subsystem isolation is not maintained, signal return currents can return on alternate paths with much larger current loop area as shown in Fig. 4.

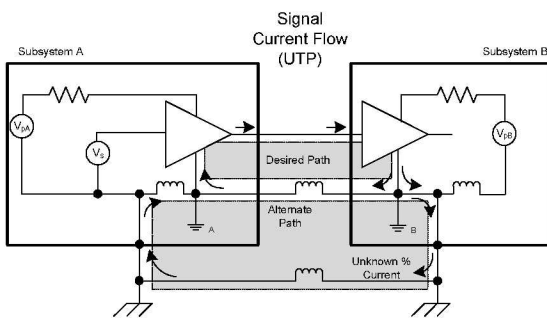

Fig. 4 Uncontrolled signal return current

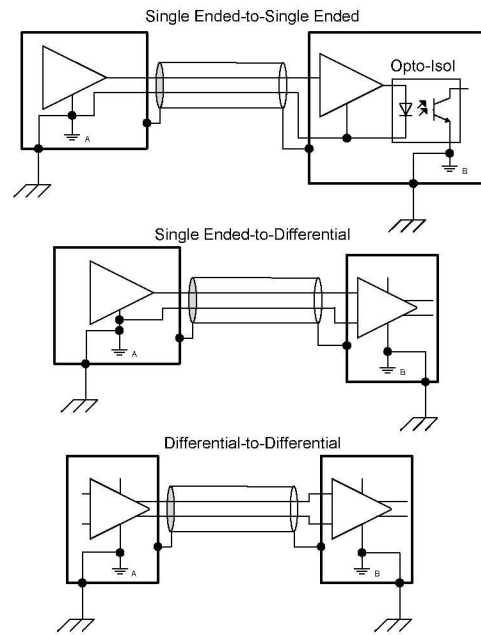

Fig. 5 Controlling signal return current

Signal return current can also be controlled through subsystem decoupling as shown in Fig. 5. Decoupling can be accomplished in a number of ways, including differential high-impedance loads, optical isolators, or signal transformers. Three cases are shown: single-ended, hybrid, and true differential-to-differential connections. Ferrites are also often used on the signal cables to minimize high frequency common-mode currents.

## II. COAX AND DIFFERENTIAL SIGNALS

There exist two obvious exceptions to the simple cases discussed above. The first is when coaxial cable is used to distribute single-ended signals. Coax is often used for low-noise signal distribution because it has excellent crosstalk immunity, and has ideally a net zero current loop area. It does however have one obvious drawback. Since the shield is also the current return path, and that shield is often tied to chassis at both ends, it creates an uncontrolled current return path.

However, an interesting phenomenon occurs to help mitigate the detrimental effects of this connection. Due to current flowing in opposite directions, the mutual inductance between the shield and center conductor acts to reduce the shield self inductance. And since the shield is concentric, the mutual inductance between the center conductor and shield is equal to the self-inductance of the shield-to-chassis circuit. The net result is a very small total shield inductance.

The importance of this effect is twofold. First, the inductance cancellation acts to limit inductive coupling into the receptor circuit [2]. But more importantly for this discussion, it also implies that the shield will act as a very low-impedance path for high-frequency return currents. This effect is illustrated in Fig. 6.

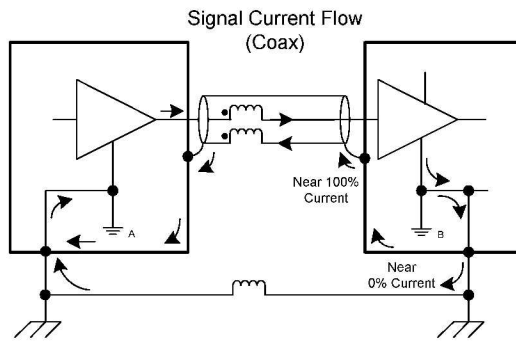

Fig. 6 Coax signal return current

A similar situation occurs when distributing differential signals across shielded twisted pair wiring. Using differential signals greatly reduces the risk of large common-mode currents flowing in a circuit, as well as improves the cancelation of common-mode voltages. However, once again the shield introduces the uncontrolled current path for parasitic common-mode as shown in Fig. 7. The differential signal currents flow almost exclusively on the two wire conductors. The small common-mode current can return either on the shield or the chassis. Fortunately, inductance cancelation once again reduces the cable shield inductance, making it the preferred high-frequency common-mode return path.

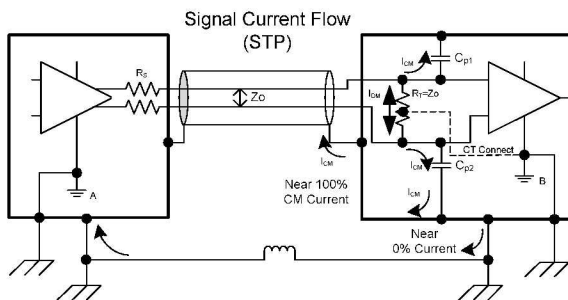

Fig. 7 Differential signal return current on STP wiring

### III. EXPERIMENTAL DATA

In our experiment, a simple source-load electronic system was created as shown in Fig. 8. A fixed-amplitude single-ended or differential signal was injected, and the common-mode cable current was measured. The common-mode cable current is an indirect measure of the current that returns on the chassis. Ideally, it would measure zero, and all of the current would flow on the cable. Several different cable/signal types were examined, as shown in Table 1. Note that the shields were terminated using either 360° or pigtail connections. Also differential loads were tested with and without center tap connections to ground.

Total source currents were calculated using the known signal levels and load impedance. The common-mode (CM) currents were measured along the cable using a current probe (with associated probe correction factor). The ratio of chassis current (sum of all CM currents) to the total signal current was then calculated. The measured results are given in Fig. 9.

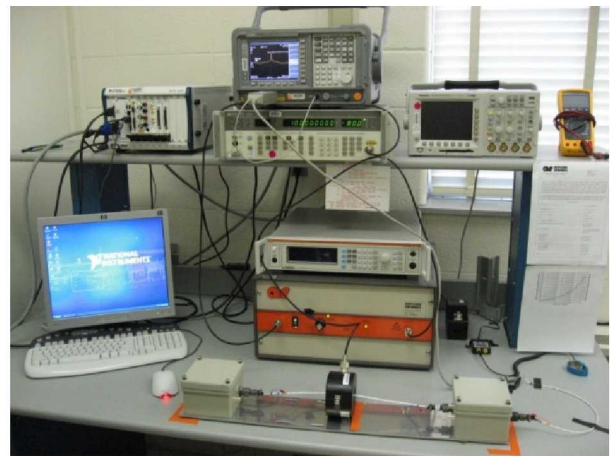

Fig. 8 Experiment test setup

TABLE 1  
TEST CASES

Case	Signal	Cable Type	Shield Termination	Load
COAX	SE	Coax	360°	$R_L = Z_0$
SE-STP	SE	STP	360°	$R_L = Z_0$
DIFF-STP-1	DIFF	STP	360°	$R_L = Z_0$ , no CT
DIFF-STP-2	DIFF	STP	360°	$R_L = Z_0$ , with CT
DIFF-STP-3	DIFF	STP	Pigtails	$R_L = Z_0$ , with CT
SE-UTP	SE	UTP	No shield	$R_L = Z_0$
DIFF-UTP	DIFF	UTP	No shield	$R_L = Z_0$ , with CT

SE = single ended, DIFF = differential, STP = shielded twisted pair, UTP = unshielded twisted pair, CT = center tap connection

Several things can be observed from the data. First, is that the return current flowing back along the chassis drops off as the frequency increases. This is due to the inductance cancellation effects discussed previously. Second, is that the single-ended signal on unshielded wiring has significantly more current returning on the chassis than any other case. The curve implies that the return wire impedance is along the same order as the chassis inductance, the ratio of which becomes independent of frequency above about a few hundred kHz. Third, is that differential signalling significantly reduces common-mode currents (as is expected). And finally, we observe that when using coax and shielded pair wiring even with single-ended signalling, the chassis common-mode currents drops off rapidly to the point where there is less than 1% current returning on the chassis at frequencies above 100 kHz.

The results demonstrate why it is often permissible to violate subsystem isolation through cable shield connections. Even when tying the shield to chassis at both ends, the return current is well controlled (> 99% returning on the close-proximity shield or conductor) for frequencies above 100 kHz. It also demonstrates how differential signalling greatly reduces common-mode currents across all frequencies.

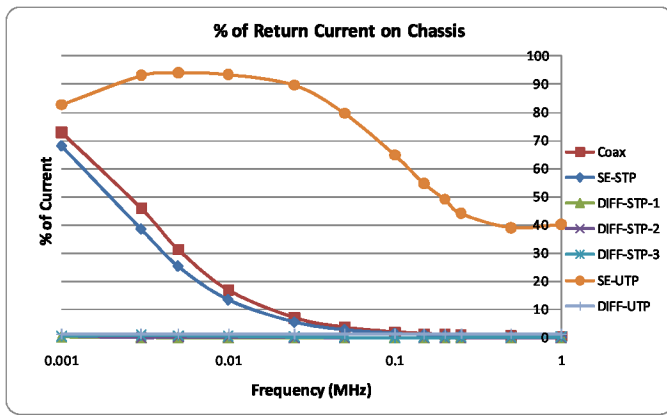

Fig. 9 Data - return current on chassis

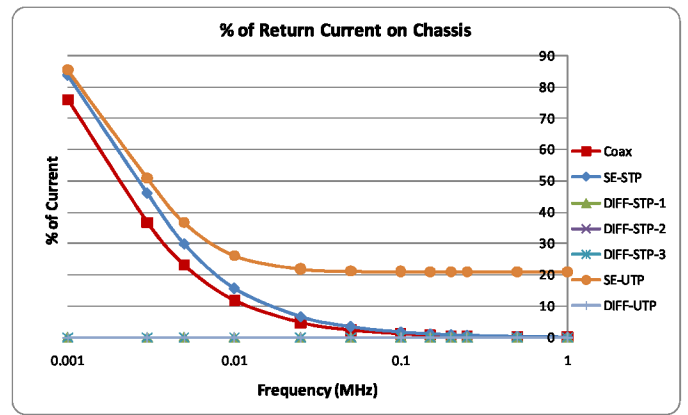

Fig. 11 Simulation - return current on chassis

#### IV. SIMULATION

It is instructive to compare PSPICE simulations to the measured data. Each of the seven test cases was simulated using model parameters extracted for our physical experiment. Equations for those extracted parameters are omitted for brevity. Fig. 10 shows the PSPICE model for the DIFF-STP-2 case, presented only as an example of the simulation methods.

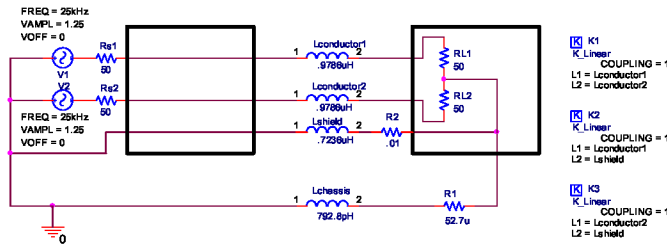

Fig. 10 PSPICE model for DIFF-STP-2

The results of simulation are shown in Fig. 11 and look similar to the measured data of Fig. 9. The same trends are observable, as well as the approximate frequency (100 kHz) at which 99% of the current returns on the shield or adjacent conductor. The difference between measurement and simulation are attributed primarily to inaccuracies in model parameter extraction (e.g. inductances, resistances).

#### V. SUMMARY

In this paper, the return current path for various signal and cable types is examined across frequency for a simple source and load resistive circuit. Measurements and simulations agree that the vast majority (> 99%) of current returns on cable shields and adjacent conductors above about 100 kHz. Data also demonstrates that as frequency decreases, more of the current returns on the low resistance chassis – an undesirable occurrence. The implications of this experiment are three fold. First it suggests that different forms of subsystem isolation (e.g. balanced differential connections, optocouplers, and signal transformers) can significantly reduce undesired common-mode currents and current loop areas. It also demonstrates the impact of compromising ground isolation through shield connections or dedicated return wires. And finally, the data implies that imperfect ground isolation becomes less problematic at higher frequencies if an adequate low loop area return path is available (i.e. a shield or return wire).

#### VI. REFERENCES

- [1] C.R. Paul, *Introduction to Electromagnetic Compatibility*, 2<sup>nd</sup> ed., Wiley Interscience, New Jersey, 2006.
- [2] M. Mardiguian, *Handbook Series on Electromagnetic Interference and Compatibility: Volume 2 – Grounding and Bonding*, Interference Control Technologies, Virginia, 1988.
- [3] H.W. Ott, *Noise Reduction Techniques in Electronic Systems*, 2<sup>nd</sup> ed., Wiley Interscience, New York, 1988.
- [4] D.A. Weston, *Electromagnetic Compatibility Principles and Applications*, 2<sup>nd</sup> ed., Marcel Dekker, New York, 2001.
- [5] D.H. Trout, N.F. Audeh, *Evaluation of Electromagnetic Radiated Susceptibility Testing using Induced Currents*, Aerospace Conference, 1997.