

LUNAR DAYLIGHT EXPLORATION

Cost Constrained Human and Robotic Exploration
Brand Norman Griffin¹ A.M., ASCE

ABSTRACT

With 1 rover, 2 astronauts and 3 days, the Apollo 17 Mission covered over 30 km, setup 10 scientific experiments and returned 110 kg of samples. This is a lot of science in a short time and the inspiration for a barebones, return-to-the-Moon strategy called Daylight Exploration. The Daylight Exploration approach poses an answer to the question, “What could the Apollo crew have done with more time and today’s robotics?” In contrast to more ambitious and expensive strategies that create outposts then rely on pressurized rovers to drive to the science sites, Daylight Exploration is a low-overhead approach conceived to land near the scientific site, conduct Apollo-like exploration then leave before the sun goes down. A key motivation behind Daylight Exploration is cost reduction, but it does not come at the expense of scientific exploration. As a goal, Daylight Exploration provides access to the top 10 science sites by using the best capabilities of human and robotic exploration. Most science sites are within an equatorial band of 26 degrees latitude and on the Moon, at the equator, the day is 14 Earth days long; even more important, the lunar night is 14 days long. Human missions are constrained to 12 days because the energy storage systems required to operate during the lunar night adds mass, complexity and cost. In addition, short missions are beneficial because they require fewer consumables, do not require an airlock, reduce radiation exposure, minimize the dwell-time for the ascent and orbiting propulsion systems and allow a low-mass, campout accommodations. Key to Daylight Exploration is the use of piloted rovers used as tele-operated science platforms. Rovers are launched before or with the crew, and continue to operate between crew visits analyzing and collecting samples during the lunar daylight.

SCIENTISTS WANT SITE DIVERSITY FOR LUNAR EXPLORATION

There are many reasons to return to the Moon, but the most compelling are for the activities that can only be accomplished on the Moon. For NASA’s Exploration Systems Architecture Study, lunar scientists identified 10 top sites for exploration. (Figure 1) Other studies have chosen different sites, but the important, mission-driving requirement is that the sites are diverse and thus, not close to one another.

¹ Gray Research, Inc., Jacobs Engineering ESTS Group, 655 Discovery Drive, Huntsville, AL 35806; PH (256) 319 8260; email: bgriffin@gray-research.com

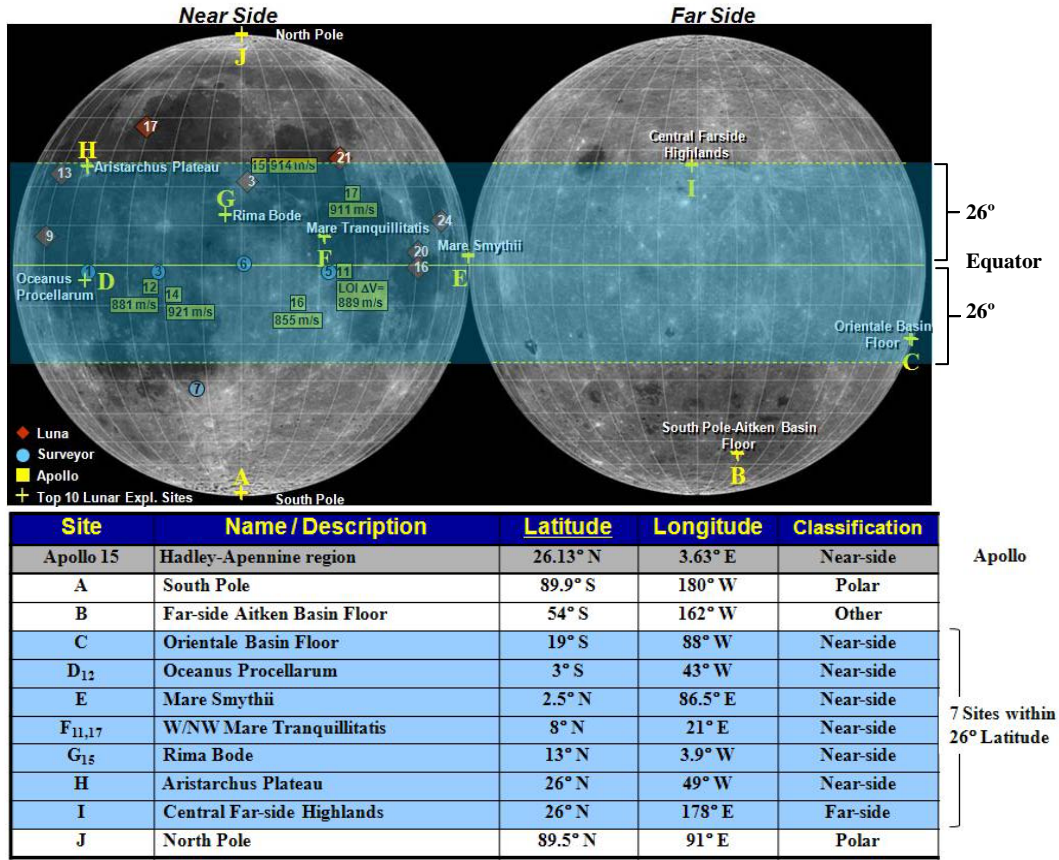

Fig. 1 Top 10 Science Sites

TWO METHODS OF EXPLORATION

Methods for exploring the scientifically diverse sites can be grouped into two categories. (Figure 2) One establishes a fixed base from which astronauts travel to and from the exploration sites. The other eliminates surface transit, landing astronauts at or close to the exploration site.

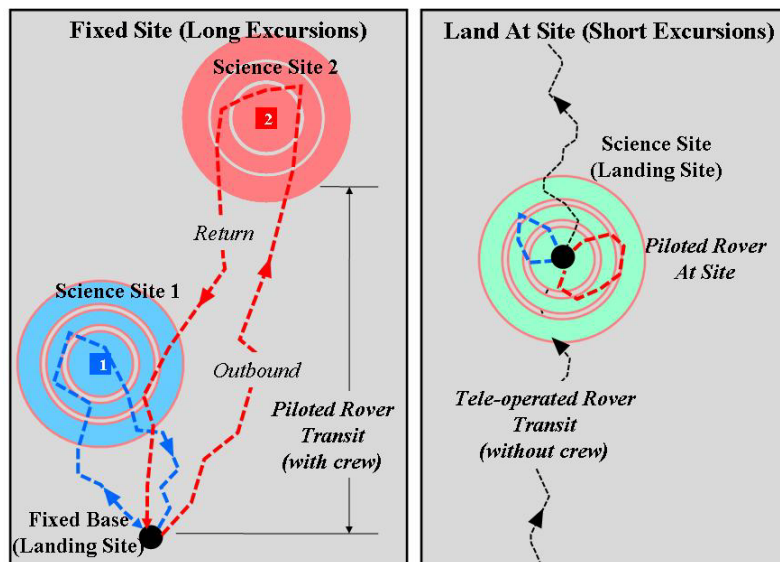

Figure 2 Two Methods of Exploration

astronauts at or close to the exploration site.

Fixed Base Exploration

For exploring the scientific sites, the fixed base method comes with a substantial overhead. Rovers provide the means to reach the sites, but in the event they are disabled rovers are limited to an EVA walk-back radius of 10 km. A

way to extend this range is to have two rovers, each with the capacity to accommodate the other crew members. Unpressurized rovers are good for short distances but for sites that are days from the base, pressurized rovers are the only reasonable option. And like unpressurized rovers, two are required in case of failure.

Pressurized rovers require power for mobility but also must provide power for all the systems that maintain a safe, habitable environment for the crew. Typically, solar energy is used to power lunar rovers and, on the Moon, access to sunlight varies by latitude, topography and annual/diurnal cycles. Because the Moon's rotational axis is inclined only 1.5 degrees to the ecliptic, it offers near continuous sunlight at the poles. But, due to terrain features even polar rovers must be designed to operate in shadowed areas and during periods of solar eclipse. Most scientific exploration sites are not at the poles and subject to a pattern of 14 days of sunlight and 14 days of dark. This means unless there is sufficient energy storage for nighttime operations, round-trip excursions must be conducted during daylight. Nominally, 300 km is a good planning radius for daylight exploration.² Unfortunately, there are no ESAS sites within 300 km of one another. (Figure 3)

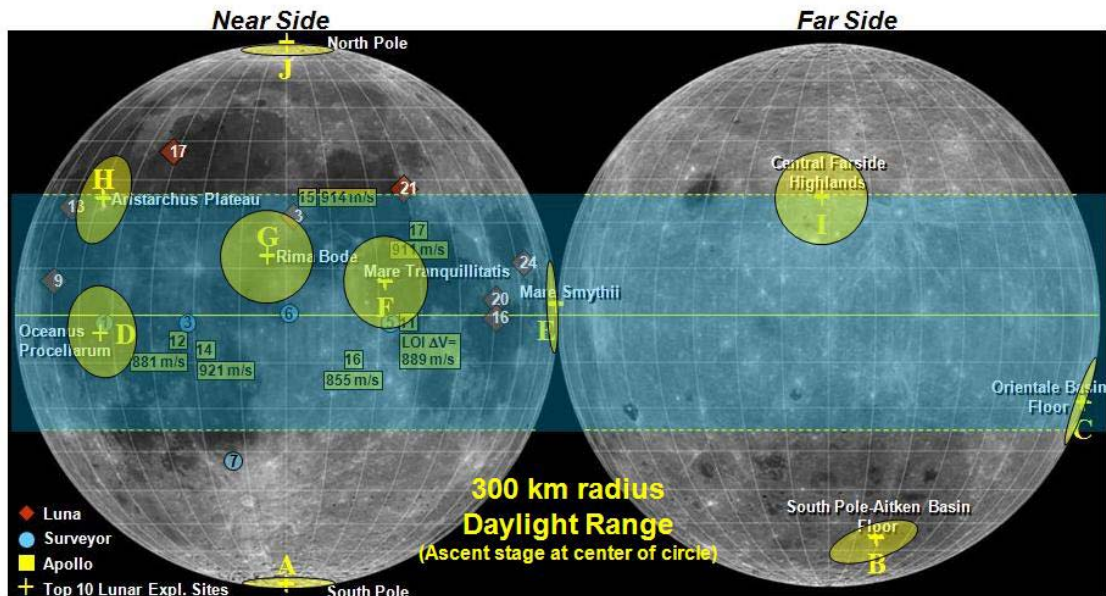

Fig. 3 Astronauts in rovers explore out to 300 km during daylight

So, if one exploration site serves as a base, getting to another site requires at least 2 pressurized rovers each with energy storage for nighttime operations. Furthermore, this mode of exploration requires returning to the base for servicing, maintenance, resupply and Earth return for the crew. Longer and longer transit times, or overhead, are required to reach the other scientific sites from a base adding risk to both the mission and crew.

Current studies show in excess of 20 landers are required to construct, resupply and deliver crews to the fixed site. Fixed base surface systems, such as habitats and infrastructure elements tend to be the largest and most massive payloads

² Assume a 12 day useable sunlight window, 3 days at the site (Apollo rover missions), traveling at 8 km/hr for 8 hrs/day, 4.5 days out and return.

for the transportation system. Consequently, these elements size a large and costly transportation system.

Maintaining a delivery schedule places a burden on all facets of the transportation system. From fabrication, ground processing, launch to lunar landing the transportation system must provide routine crew and cargo deliveries to sustain the base operations. For all these reasons, a fixed base approach to scientific exploration comes with significant overhead that adds cost and schedule risk to actual objective of site analysis.

Land at Site-Explore in Daylight

The other exploration mode has no fixed base, and like Apollo, lands at the science site. With this method, 10 landers can visit all of the ESAS sites versus over 20 for the fixed base. In addition to fewer flights another benefit of this approach is that rover excursion distances are focused on local exploration rather than traveling to and from the science site. This eliminates the risk of multi-week traverses over rough terrain and nighttime operations along with the additional system mass and volume, enroute consumables, wear and tear on the equipment and driving fatigue. Furthermore, landers and the transportation elements can be smaller because there are no habitats or infrastructure to deliver and setup; nor is there a need for offloading equipment or resupply flights. Another important advantage is the freedom to schedule flights according to scientific and equipment readiness, solar cycles, cost or changes in priorities.

There should be no problem landing at the science site because precision landing on the Moon was demonstrated when the second manned landing, Apollo 12 touched down within 183 m of the previously landed Surveyor 3 spacecraft.(Figure 4)

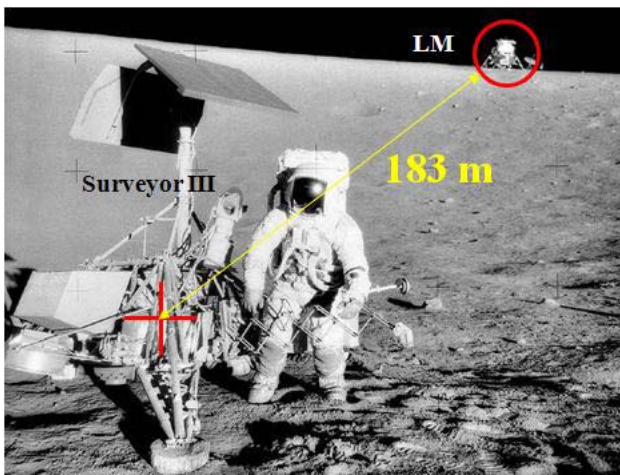

Fig. 4 Landing accuracy reduces transit time

Such accuracy reduces risk because it allows careful preflight training of EVA and rover excursions. Because the crew arrives directly at the science site, only short drives are required. Apollo 17 astronaut/geologist Harrison Schmitt said, “You didn’t need to go very far (away from the Lunar Module) in order to reach all the interesting places that we wanted to get to in the time we had available.” Depending on objectives and site area, surface stay times could be up to 14 days, but planning for 12 days provides launch flexibility and a greater chance of unobstructed sunlight. The longest Apollo mission was 3 days. During their stay the astronauts drove 30.5 km, setup 10 scientific experiments and collected 110 kg of samples for Earth return. Considering the same average range per stay for the Apollo LRV missions it is possible to cover over 110 km during a 12 day stay.(Figure 5)

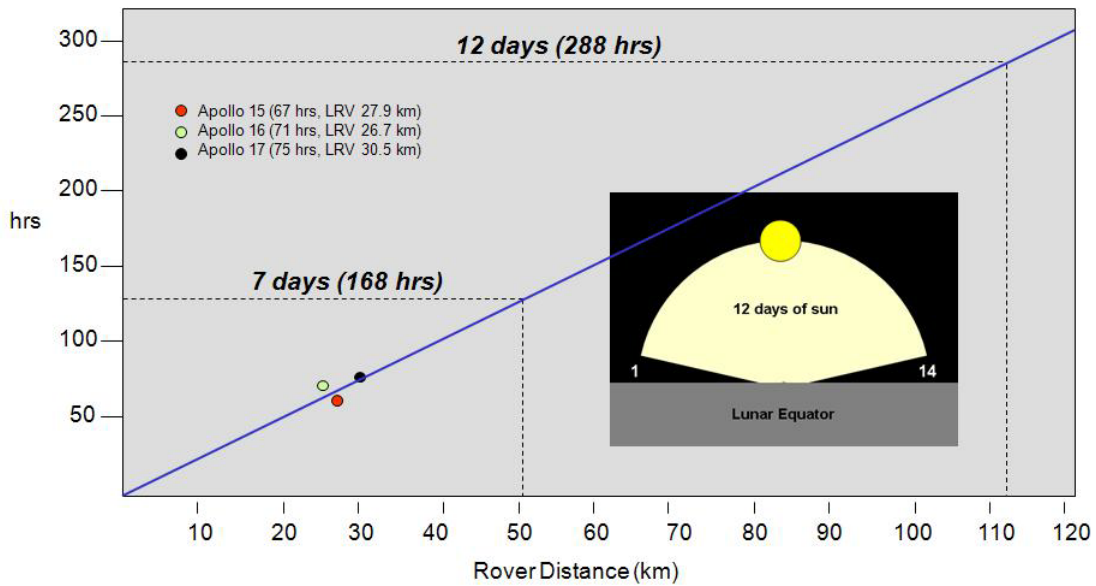

Fig. 5 Daylight Exploration Range using the Apollo LRV rate

Daylight Exploration expands the area of coverage and duration of Apollo by adding robotic rovers. These rovers are tele-operated from Earth and can either be unpressurized or pressurized. They arrive before the crew and continue working during the daylight between crew visits. The rovers are equipped with cameras, sensors and manipulators to provide scientists with a broad range of assessments and sample collection capability. Robotic operations offer the benefit of long observation times that are not constrained by crew fatigue or space suit consumables. Rovers identify high value sites for the crew to visit as well as bring the crew carefully selected samples for further analysis and possible return. Although not required, rovers designed to be used by the crew and tele-operated are an efficient method of exploration because astronauts do not have to bring a rover on every mission. Before the crew leaves the Earth, rovers are pre-positioned at the lunar landing site waiting for their arrival.

With the addition of robotic rovers, there is a significant increase in the range and duration of exploration. In the 1960s, the Russian Lunakhod rover averaged 1 to 2 km/hr. While operating in the daylight only, the first tele-operated Lunakhod rover traveled 35 km and the second 37 km. Operating at 1 km/hr for 8 hr/day during 12 days of sunlight is 96 km/month. If the rover is delivered two years before the crew it is possible to travel 2304 km. This is 2/3 the diameter of the Moon. Even at 0.33km/hr, the rover can cover 768 km in this period of time.

Figure 6 shows how a tele-operated pressurized rover delivered before the crew arrives analyzes and collects sample during daylight over a 768 km excursion. Then, the rover is pre-positioned at the landing site ready for the crew to board and return to 2 sites that were identified as scientifically rich. They drive 160 km at 8 km/hr reaching the furthest site in 2 ½ days then depending on work to be accomplished at each site return to the ascent vehicle within the next 2 ½ to 5 days. The crew can either return or use the remaining daylight to explore the region.

However, after the crew leaves, the rover resumes its tele-operated mode for continued exploration.

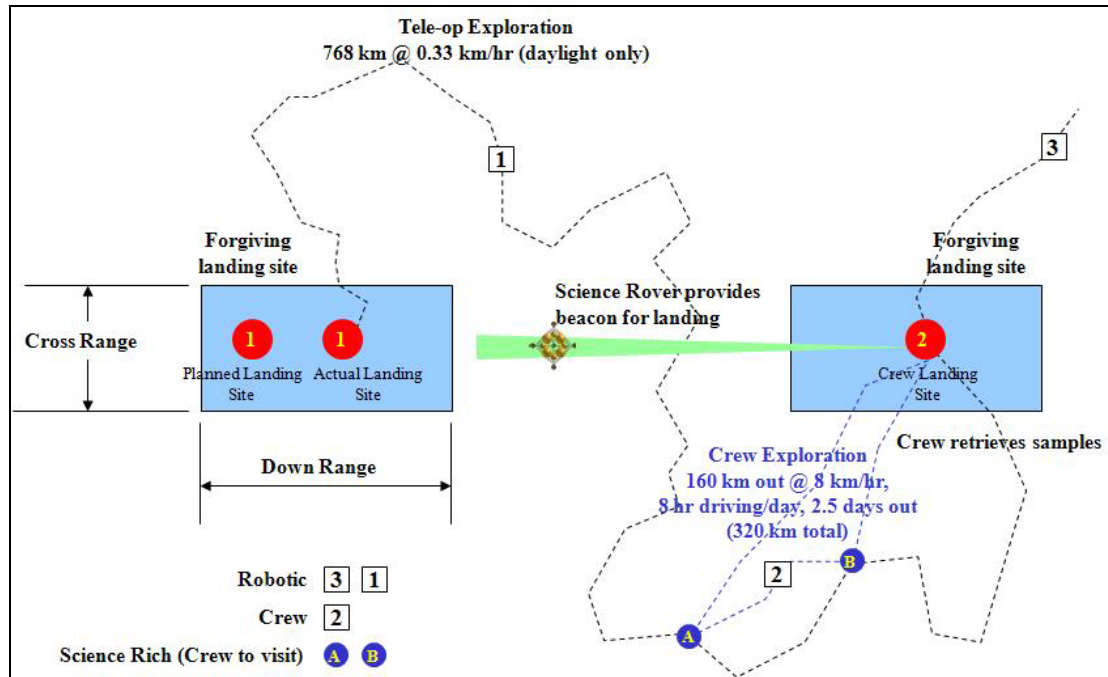

Fig. 6 Tele-operated rovers collect samples between crew visits

THE ADVANTAGES OF SHORT MISSIONS

Creating missions for lunar daylight means the crew stays no more than 14 days. Other exploration strategies are interested in accumulating surface stay time, but for Daylight Exploration, short missions are preferred. In fact, these short missions are not real short because they can be up to 4 times as long as Apollo missions and include on-going robotic missions.

The advantages of daylight operations are low mass, volume and power as well as less complex systems that do not require nighttime energy storage for operations. Unlike long missions, more compact and lightweight campout accommodations are acceptable for short stays. Another very important benefit is reduced exposure to space radiation. Because it is difficult to shield against Galactic Cosmic Rays, limiting exposure time is the preferred method of protection. Another radiation source, Solar Particle Events (SPEs) can be lethal and are hard to predict occurring with little warning time. Apollo crews were fortunate to have avoided a large SPE. This means that regardless of mission duration SPE protection should be provided. The only advantage short missions offer is that they can be planned around solar cycles to reduce the risk of an event occurring.

Even with countermeasures, there is physiological degradation due to long term exposure to weightlessness. In 1/6 g, it is assumed there will be some degradation for long stays on the Moon. The important issue is that Earth entry from the Moon experiences higher g-loads than a space station return thus increasing the stress to the cardio vascular system. Shorter stays help retain physiological conditioning increasing the ability to endure re-entry loads and minimize recovery.

Another benefit is that short stays avoid the risks associated with time-sensitive equipment both on the surface and in orbit. Ascent and orbiting propulsion systems must operate for the crew to return to Earth. Over time, pressurized systems leak, propellants boil-off, water sublimates, batteries lose performance and space suits require servicing. Furthermore, starting ascent and orbiting engines after 12 days will be more predictable than after 6 months in the space environment. Simple Environmental Control Life Support systems can be used for short missions, whereas long stay systems are more complex, require more power and weigh more. Any flight from the Earth to the lunar surface is significant. Part of the reason that long stay missions have so many flights is that they require resupply. There are no resupply flights for Daylight Exploration.

UNPRESSURIZED AND PRESSURIZED ROVERS

The Space Shuttle is a system that transports crew and cargo together. Because there are different requirements for these payloads, the next transportation systems will launch them separately. Daylight Exploration uses a similar approach allowing independent access to the lunar surface.

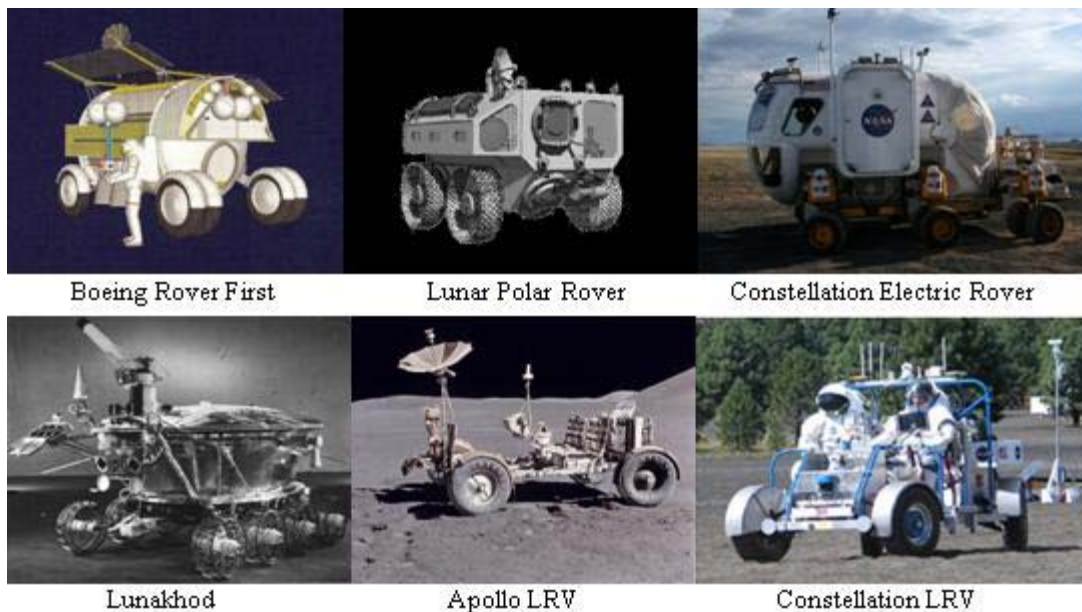

Fig. 7 Unpressurized and pressurized rovers for exploration

The Europeans and Japanese have plans to develop lunar landers with a payload mass between 800 and 1000 kg. Considering that the mass of the Apollo Lunar Roving Vehicle (LRV) was 210 kg, the Lunakhod 840 kg and estimates for a Constellation class LRV are around 300 kg, these delivery systems can land 1 and in some cases 2 unpressurized rovers.(Figure 7)

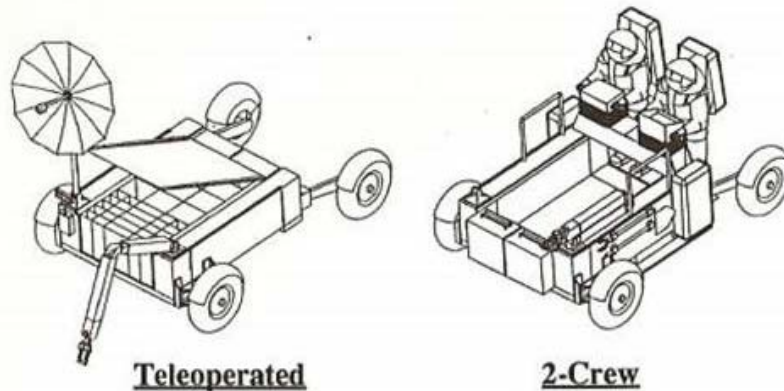

Figure 8 Dual Mode (piloted and robotic) rovers

Tele-operated unpressurized rovers survey, assay and collect samples, but when used by the crew, offer no radiation protection. (Figure 8) Therefore, when the crew uses unpressurized rovers, they must be within the warning time of a shelter. Both pressurized rovers and ascent vehicles can be designed to provide SPE protection. These shelters for 2 crew members that use water or polyethylene are estimated to be approximately 500 kg. Therefore, a rover equipped with a shelter is preferred because the additional mass stays on the surface and does not have to be transported on every flight.

TARGETED (MINIMAL) EVA

EVA comes at a risk, but provides capabilities not available by any other means. Daylight Exploration is conceived to minimize risk yet get the most out of human and robotic systems. When the crew arrives, tele-operated rovers provide samples collected over the months between visits and have also identified sites for the crew to visit. Using pressurized rovers equipped with sensors, manipulators and tools, the crew explores these sites. This approach allows EVA to be targeted to areas best explored by the crew in suits. This not only reduces risk, but minimizes suit wear and the water and gas loss associated with EVA.

TWO CREW MEMBERS

The Russians planned to send one cosmonaut to the lunar surface and Apollo sent two astronauts with one remaining in orbit. Daylight Exploration can fulfill mission objectives with two crew members because of robotic precursor exploration and current state of spacecraft control. Preflight site reconnaissance by rovers allows detailed mission planning before Earth departure. Control of orbiting spacecraft from Earth has been demonstrated. Therefore, unlike Apollo, the orbiting return spacecraft is controlled from Earth and unoccupied while the crew is on the surface. For far-side sites without line-of-sight Earth communications, the orbiting return spacecraft serves as a makeshift Comsat allowing a store-forward relay system. Because spacecraft are sized by the number of crew, a two crew solution provides the most efficient arrangement while retaining the buddy system for contingencies.

MOSTLY DATA AND A FEW SAMPLES

Data is the principal product from lunar exploration. Samples returned to the Earth just offer a different method of extracting data. Daylight Exploration uses the continuous presence of rovers along with crew delivered experiment stations to provide the majority of the scientific data. Pre-selected samples collected by the rovers are further screened by the crew to select candidates worthy of return and further analysis. This reduces the return mass and is a test bed for a Mars mission concept of operations.

USE EXISTING TECHNOLOGY

No new technology is required to send humans back to the Moon. Daylight Exploration is intended to be a low risk, low cost program with emphasis on safety and reliability. Today's technology offers many benefits over the Apollo era, but careful discretion is required to select and integrate these systems. The paralyzing tendency to optimize everything must be avoided. Building flight hardware brings enough challenges; that is why Daylight Exploration starts conservatively knowing that once operational systems will be upgraded over time.

TIME AND PLACE FOR A FIXED BASE

Daylight Exploration is conceived for visiting diverse scientific sites. Another purpose for going to the Moon is to take advantage of local resources. For this objective, precursor human and robotic missions identify resources and abundance in order to establish the feasibility of locating a base. Processing lunar regolith can yield oxygen, aluminum and potentially hydrogen. Recent LCROSS (Lunar Crater Observation and Sensing Satellite) findings claim "significant quantities" of water on the Moon. This can be used for making propellants to support lunar activities and other missions outside the Earth's gravity well. The near continuous sunlight at the South Pole is an important resource for supporting the base as well as any processing facility.

CONCLUSIONS

An efficient, low risk, low cost strategy for visiting diverse scientific sites on the Moon is to first explore with tele-operated rovers then send the minimum crew on short daylight missions to each separate site. Apollo had 1 rover, 2 crew and 3 days; Daylight Exploration offers 2-plus rovers, 2 crew and 12 days as a low risk achievable startup for human and robotic planetary exploration.

REFERENCES

- Jones, Eric M.(1995-2006), Apollo Surface Journal, World Wide Web,
The LK ('Lunniy korabl' - lunar craft), The Soviet Lunar Lander, *Astronautix.com*
Larson, W.J. and Pranke, L.K., *Human Spaceflight Mission Analysis and Design*,
McGraw Hill, ISBN 0-07-236811-X
Lunar Surface Mission Team, June 7, 2006, *NASA Lunar Architecture Requirements Preparatory Study*
Than, Ker (2009). "Water on the Moon Confirmed by NASA Crashes" *National Geographic News*



American Society of Civil Engineers
Earth & Space 2010 Conference
17 March 2010



Lunar Daylight Exploration

Brand Griffin
Gray Research/Jacobs Engineering
Huntsville, AL

Apollo Exploration

1
Rover

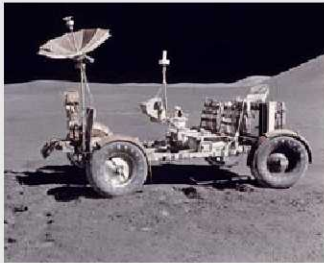

36 km traverse (Apollo 17)
Constrained by EVA walk back

2
Astronauts



2 Crew on the surface
One on orbit

3
Days

December 1972

Sun	Mon	Tue	Wed	Thu	Fri	Sat
					1	2
3	4	5	6	7	8	9
10	11	12	13	14	15	16
17	18	19	20	21	22	23
24	25	26	27	28	29	30
31						

Daylight Operations
299.5 hrs total Apollo (surface)



382 kg sample return (total)

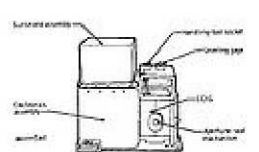
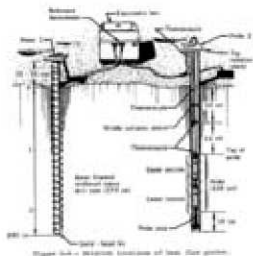
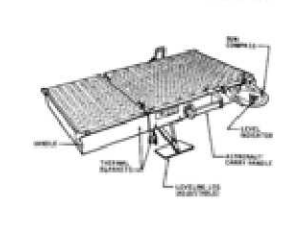
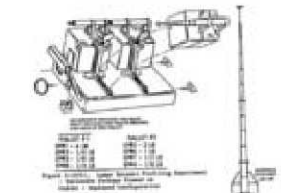
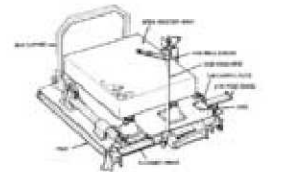
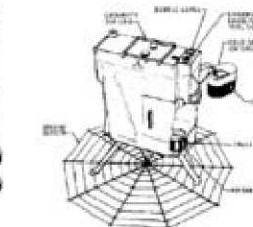
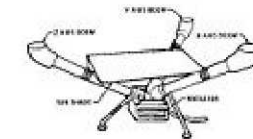
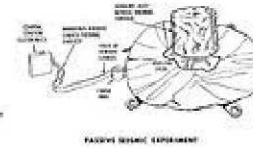
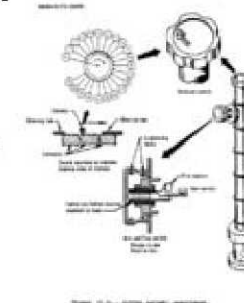
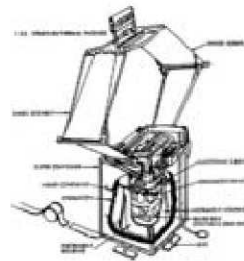
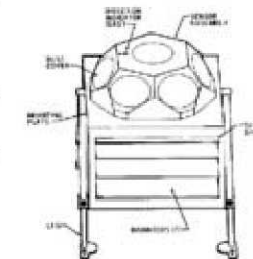
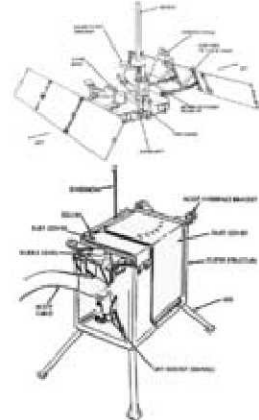

Figure 11. - The CCKO in the deployed configuration.



Apollo Experiments



Daylight Exploration

Builds on the Success of Apollo
Lunar Science Emphasis
Human + Robotics
Minimal Start Leading to Development Missions

1

Dual-Mode Rover(s)



Provides Radiation Protection
Extends Exploration Range
Works between Crew Visits

2

Astronauts



Minimal Crew
(no crew on orbit)
Small lander
Small transfer vehicle

12

Days

December 1972

Sun	Mon	Tue	Wed	Thu	Fri	Sat
					1	2
3	4	5	6	7	8	9
10	11	12	13	14	15	16
17	18	19	20	21	22	23
24	25	26	27	28	29	30
31						

288 hrs surface stay
11 hrs fewer than all Apollo missions

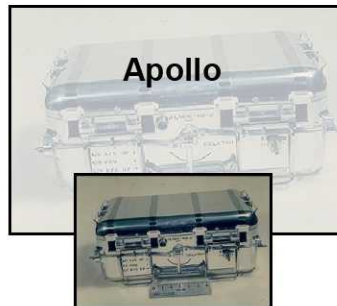
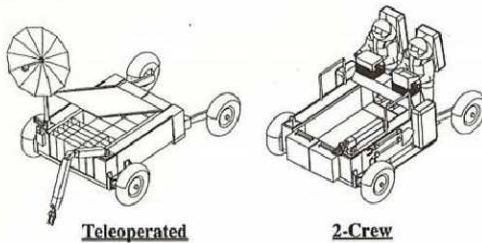

Few Samples
More Electronic Data (Mars Forward)

Hours on Surface

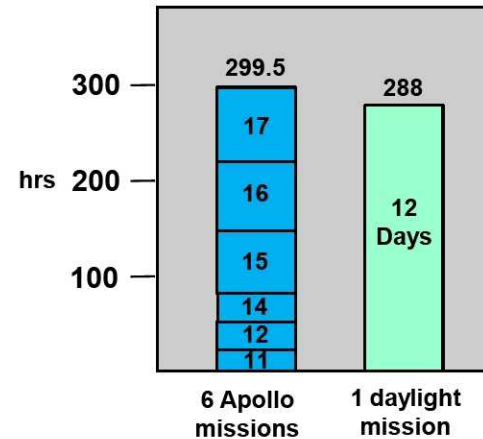

Dual Mode Operations

- **Tele-operated**

- Mobile Hab arrives before crew (approx. 2 years)
- Equipped with manipulator and sample analyzer/collector
- Operates in sunlight (dormant during shadow/night)
- Vehicle check out before crew
- Mobile Hab serves as beacon for lander
- Meets landing crew in “safe zone” then drive to science
- Mobile Hab continues after crew leaves

- **Piloted**

- Precise mission (based on scientific analysis from teleop)
- 7 to 14 day missions
- High value EVA (prior sample analysis and manipulator ops)

Two Exploration Modes

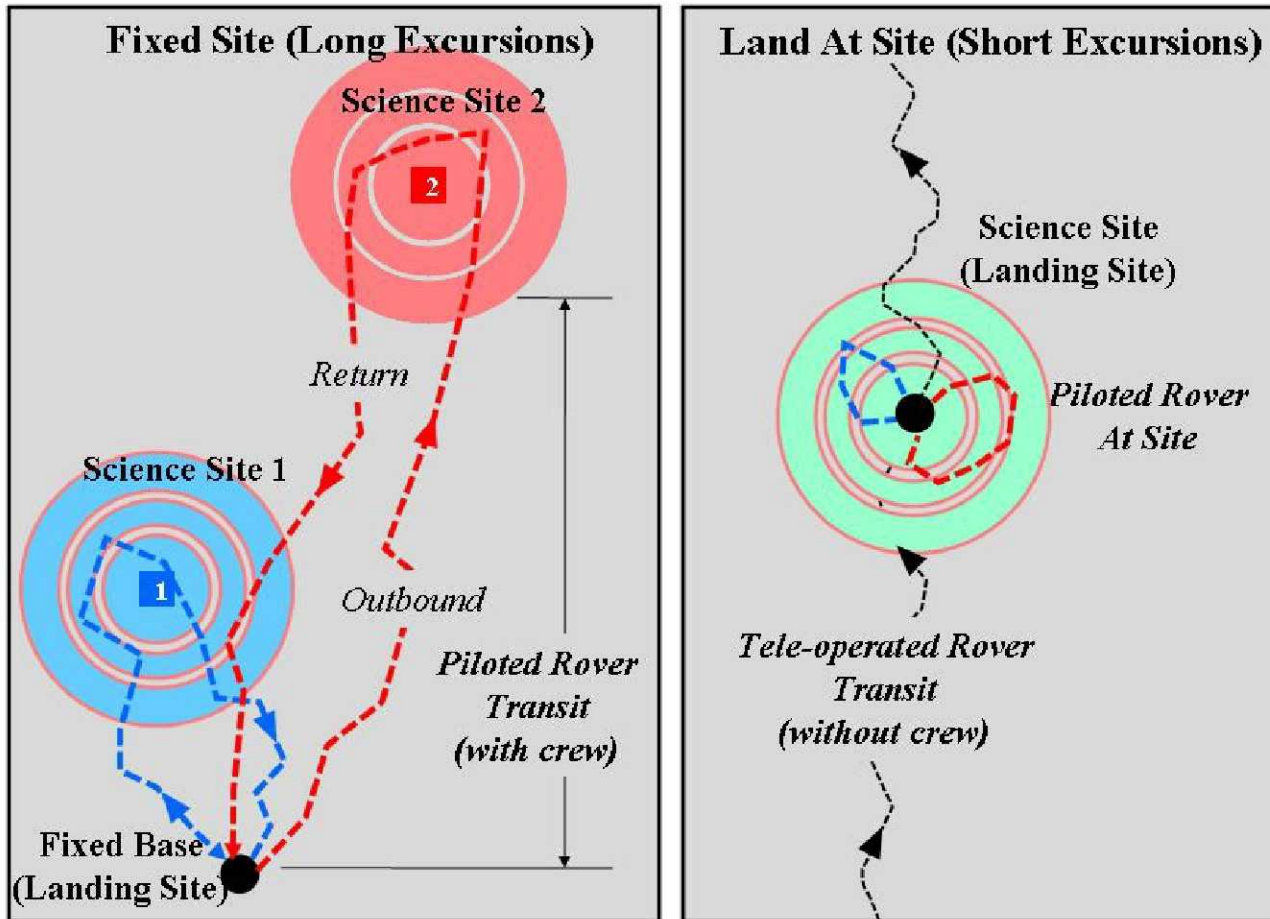

Scientists Want Site Diversity

(Sites at different locations)

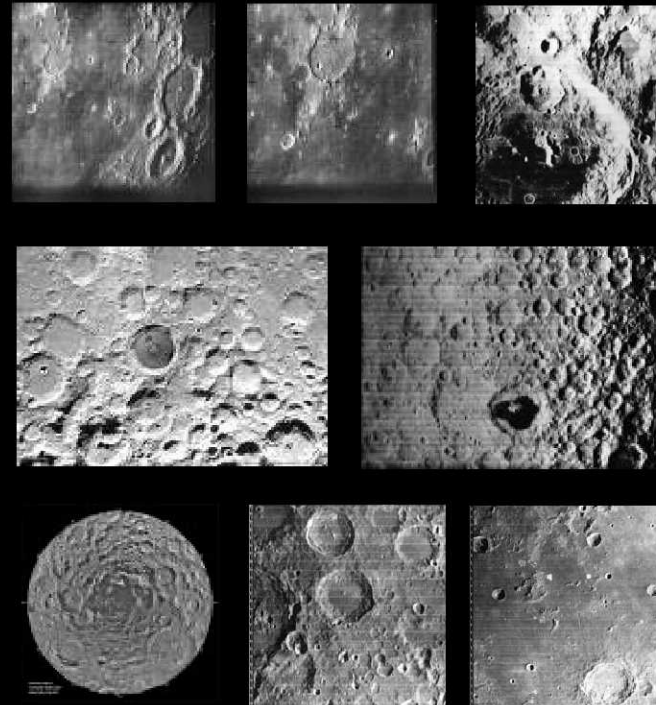

Top 10 Exploration Sites

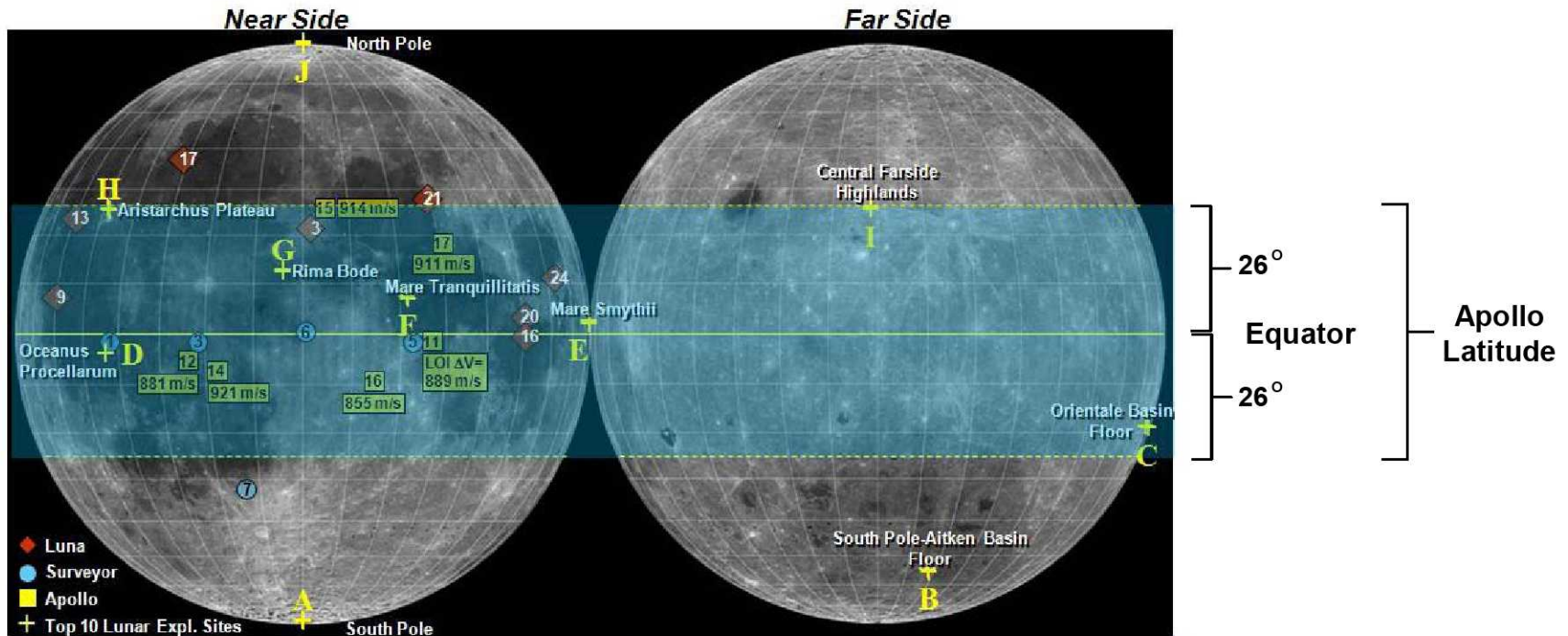

Site	Name / Description	Latitude	Longitude	Classification
Apollo 15	Hadley-Apennine region	26.13° N	3.63° E	Near-side
A	South Pole	89.9° S	180° W	Polar
B	Far-side Aitken Basin Floor	54° S	162° W	Other
C	Orientale Basin Floor	19° S	88° W	Near-side
D ₁₂	Oceanus Procellarum	3° S	43° W	Near-side
E	Mare Smythii	2.5° N	86.5° E	Near-side
F _{11,17}	W/NW Mare Tranquillitatis	8° N	21° E	Near-side
G ₁₅	Rima Bode	13° N	3.9° W	Near-side
H	Aristarchus Plateau	26° N	49° W	Near-side
I	Central Far-side Highlands	26° N	178° E	Far-side
J	North Pole	89.5° N	91° E	Polar

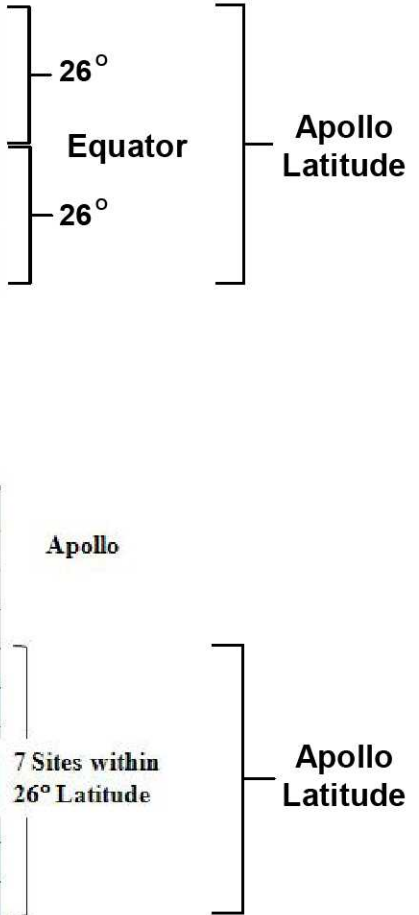

Apollo

7 Sites within 26° Latitude

Apollo Latitude

Different Exploration Strategies

Crew Time on Surface

- Notes:
- Payload (e.g., scientific research, commercial, Education and Public Outreach (EPO), International Partners, etc.) is delivered for each crewed mission
 - Logistics includes pressurized goods + CTBE bag mass, unpressurized goods + carriers, liquids + tanks, and gases + tanks

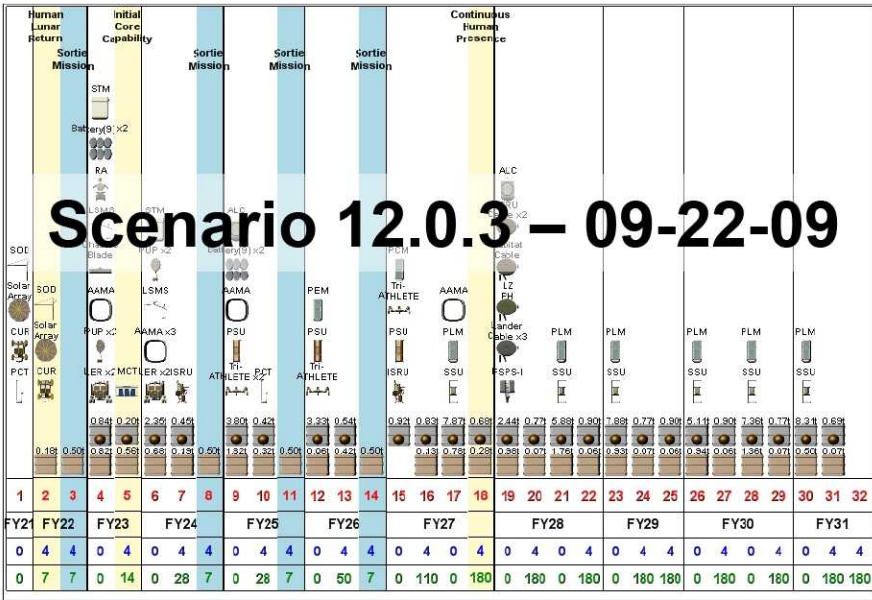

Geo-Science Exploration

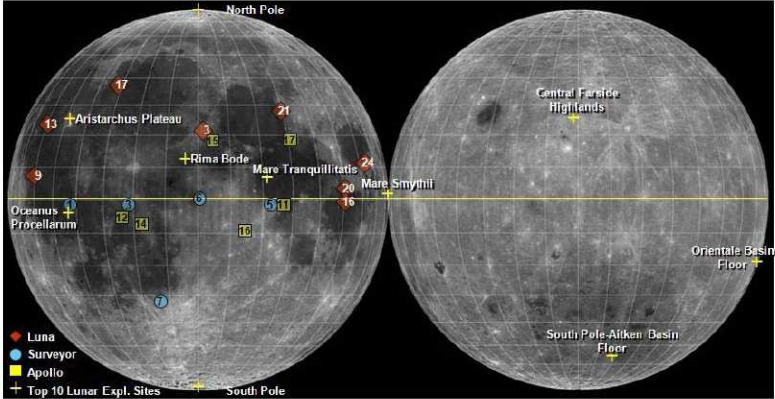

- Mission Number
- Crew Size
- Surface Duration

26 Landers to Fixed Site
4 Sorties
30 Landers to 5 Sites

10 Crew Landers
4 Robotic Landers
14 Landers to 10 + Sites

Local Excursions

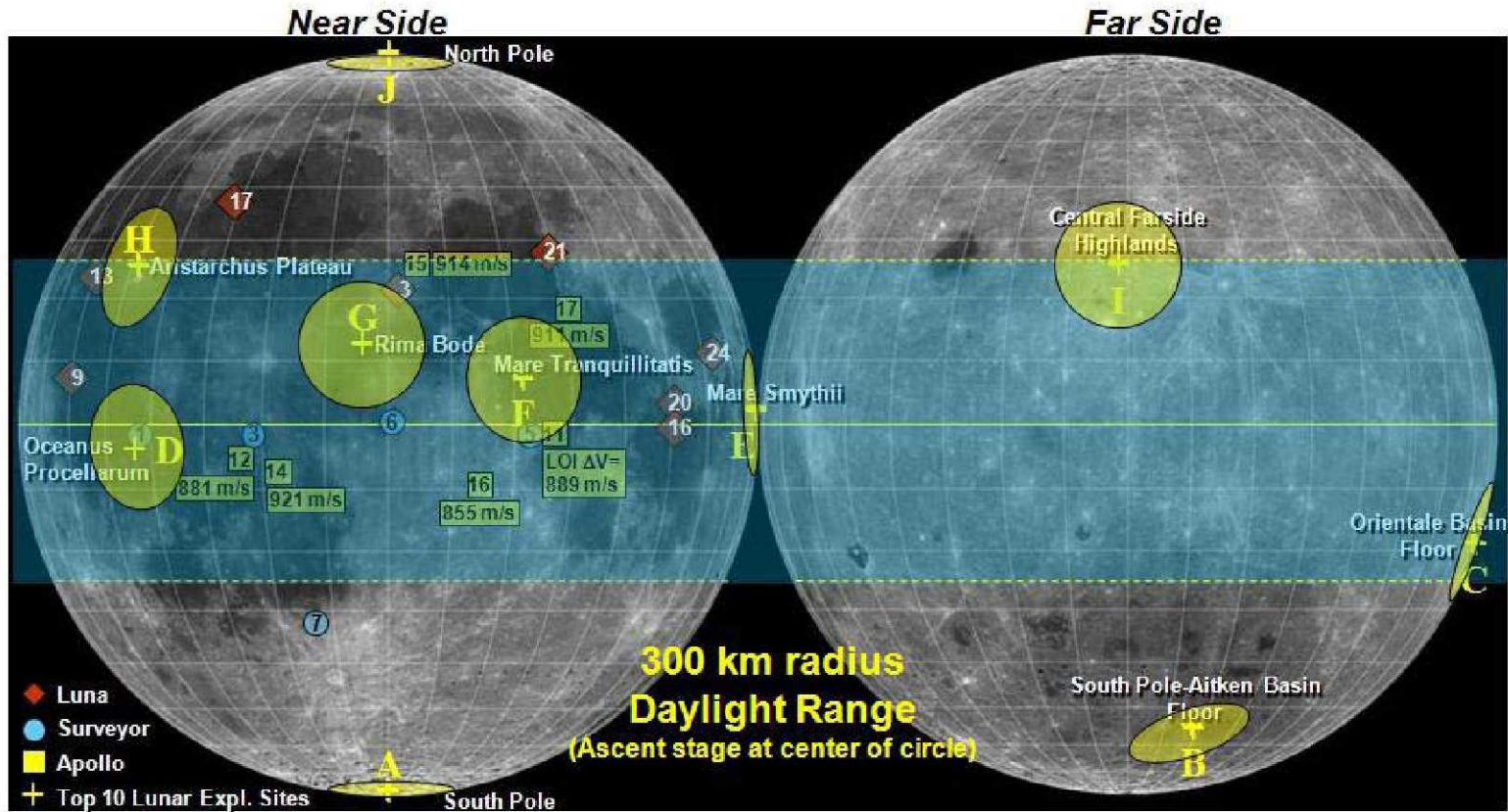

“You didn’t need to go very far (away from the Lunar Module) in order to reach all the interesting places that we wanted to get to in the time we had available.” *Harrison Schmitt, Apollo 17*

Top Ten Exploration Sites- Not Close

Long Traverse Required between Sites

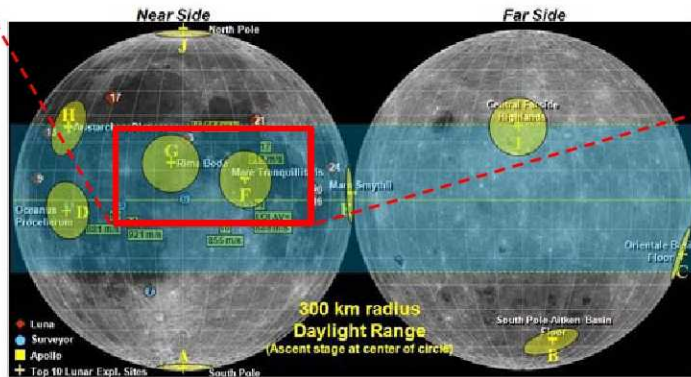

Tele-op and Piloted Range

Teleop Transit

	day	function	hrs of day	km/day	total km
Night	12				
	13				
	14				
Daylight	1				
	2	drive	16	16	
		recharge	8		
	3	drive	16	16	32
		recharge	8		
	4	drive	16	16	48
		recharge	8		
	5	drive	16	16	64
		recharge	8		
	6	drive	16	16	80
		recharge	8		
	7	drive	16	16	96
		recharge	8		
	8	drive	16	16	112
		recharge	8		
	9	drive	16	16	128
		recharge	8		
	10	drive	16	16	144
		recharge	8		
	11	drive	16	16	160
		recharge	8		
	12	drive	16	16	176
		recharge	8		
	13	drive	16	16	192
recharge		8			
14					
Night	1				
	2				
	3				

Piloted (14 day)

	day	function	hrs of day	km/day	total km
Night	12				
	13				
	14				
Daylight	1				
	2	drive	8	64	
		recharge	16		
	3	drive	8	64	128
		recharge	16		
	4	drive	8	64	192
		recharge	16		
	5	drive	8	64	256
		recharge	16		
	6	drive	8	64	320
		recharge	16		
	7	drive	8	64	384
		recharge	16		
	8	drive	8	64	448
		recharge	16		
	9	drive	8	64	512
		recharge	16		
	10	drive	8	64	576
		recharge	16		
	11	drive	8	64	640
		recharge	16		
	12	drive	8	64	704
		recharge	16		
	13	drive	8	64	768
14					
Night	1				
	2				
	3				

Piloted Mode (return to ascent vehicle)

3 days at the site

- Travel at 8 km/hr for 8 hrs/day
- 4.5 days out 4.5 days return
- 288 km radius (~300 km)



6 days at the site

- Travel at 8 km/hr for 8 hrs/day
- 3 days out, 3 days return
- 192 km radius (~200 km)

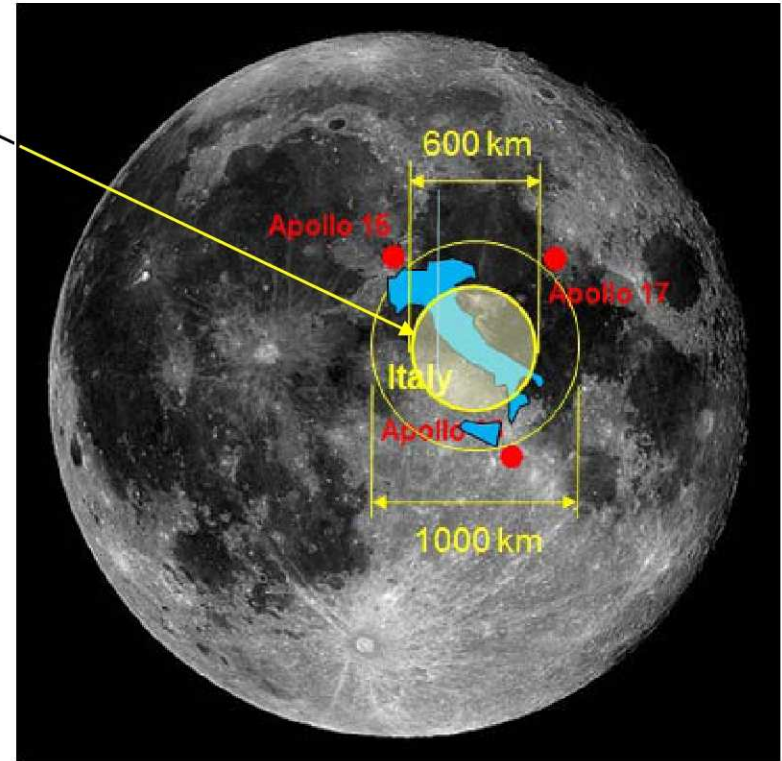

Land Close to Target

(Minimize transit time)

Second Lunar Landing (Apollo 12)

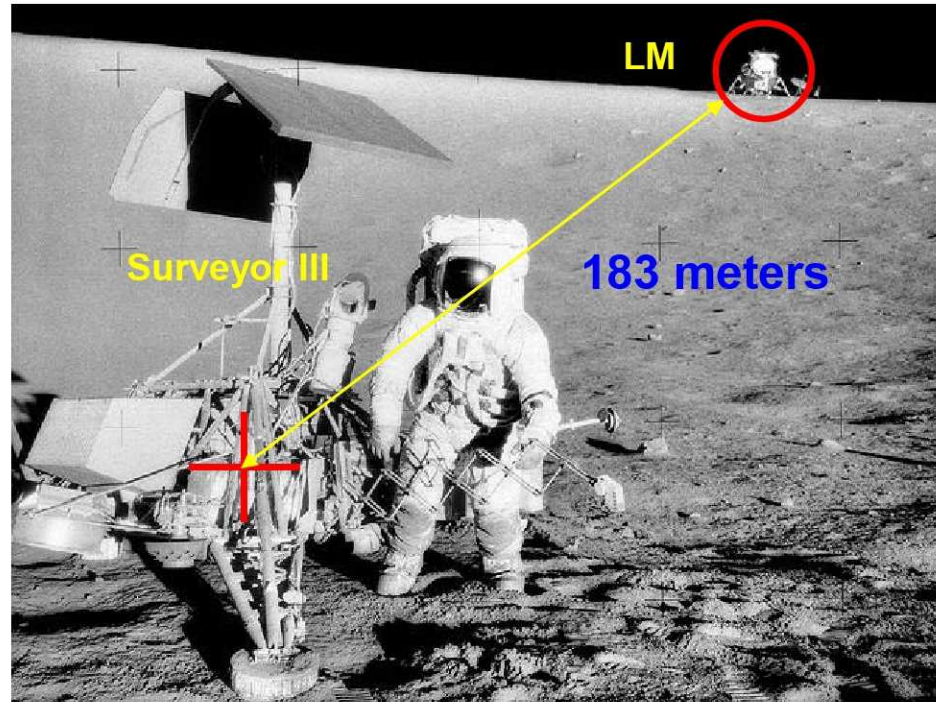
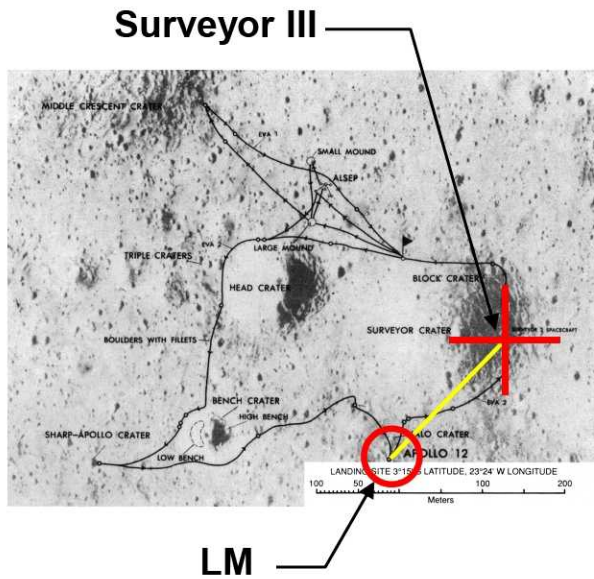

Human plus Teleop Exploration

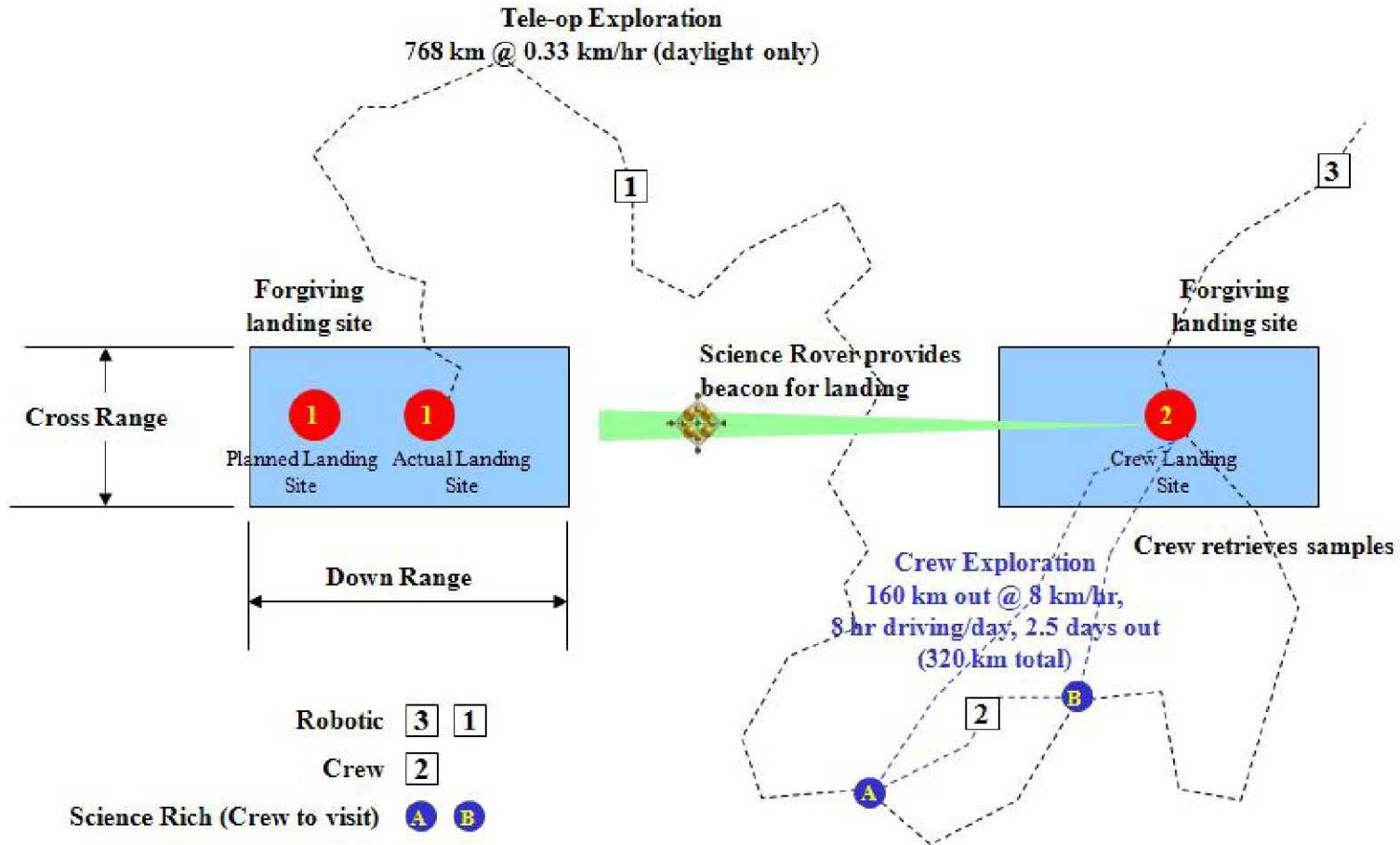

Advantages of Short Mission



- **Reduced consumables**

- Fewer days = less consumables
 - Less water consumption (EVA suit cooling)

- **Reduced Radiation Exposure**

- Less exposure to Galactic Cosmic Radiation (duration dependent)
 - Missions planned during low Solar Proton Event periods (vs. long stay)

- **Minimal physiological degradation**

- Strength for surface operations (EVA)
 - Cardiovascular conditioning for high-g reentry

- **Avoid time-sensitive concerns (surface, ascent and orbital return vehicle)**

- Leakage of pressurized systems
 - Cryogenic boil off
 - Battery performance
 - Environmental control life support system closure (short missions – less closure)

- **Smaller, lighter, “campout” crew accommodations**

- Campout provision acceptable for short stays

Many Rover Concepts



Boeing Rover First



Lunar Polar Rover



Constellation Electric Rover

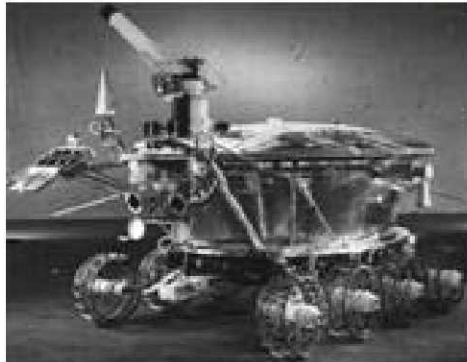

Lunakhod



Apollo LRV



Constellation LRV

Dual-Use Unpressurized Rover

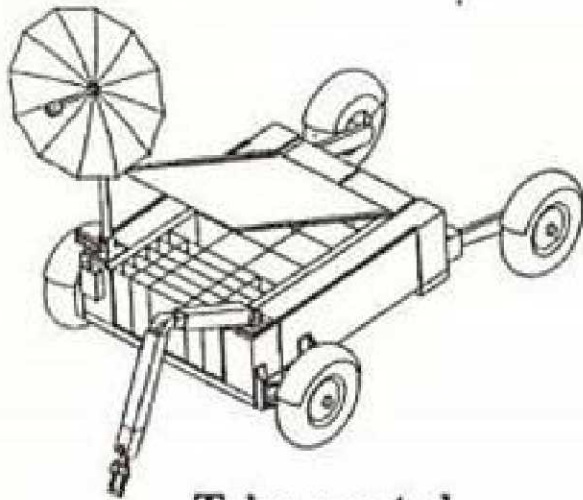

Teleoperated

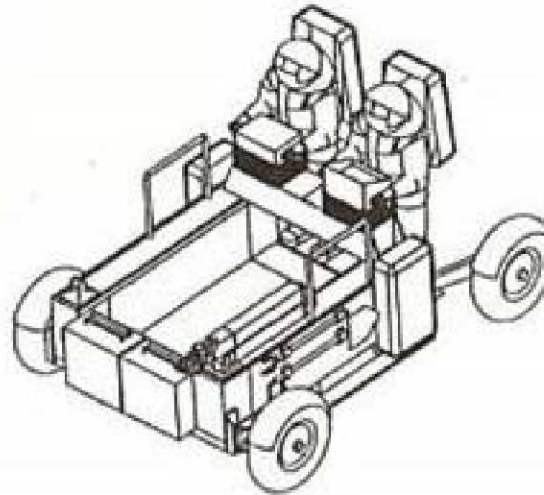

2-Crew

Conclusions



- Top 10 exploration sites are far apart (closest ~ 900 km)
- Fixed site means long traverses to exploration sites
- **Landing directly at the site** avoids “traverse risk and overhead”
- Landing accuracy has been demonstrated
- Apollo was very productive and an excellent model to follow
- **Tele-op rovers with focused human missions** improves exploration
- **Daylight missions** offer up to 4 times the Apollo surface time
- **Short stay** (daylight) missions are effective, cost less and safer than overnight missions
- Daylight exploration provides the experience and data to plan the next step (ISRU, fixed sites, etc.)

References



- Jones, Eric M.(1995-2006), Apollo Surface Journal, World Wide Web,
- The LK ('Lunniy korabl' - lunar craft), The Soviet Lunar Lander, *Astronautix.com*
- Larson, W.J. and Pranke, L.K., *Human Spaceflight Mission Analysis and Design*, McGraw Hill, ISBN 0-07-236811-X
- Lunar Surface Mission Team, June 7, 2006, *NASA Lunar Architecture Requirements Preparatory Study*
- Than, Ker (2009). “Water on the Moon Confirmed by NASA Crashes” *National Geographic News*

Lunar Rover Range

