

# International Space Station USOS Potable Water Dispenser On-Orbit Functionality vs. Design

Katherine P. Toon<sup>1</sup>

*NASA Lyndon B. Johnson Space Center 1, Houston, TX, 77058*

Randal W. Lovell<sup>2</sup>

*Barrios Technology, Houston, TX, 77058*

The International Space Station (ISS) currently provides potable water dispensing for rehydrating crewmember food and drinking packages. There is one system located in the United States On-orbit Segment (USOS) and one system in the Russian Segment. Shuttle mission STS-126 delivered the USOS Potable Water Dispenser (PWD) to ISS on ULF2; subsequent activation occurred on November 2008. The PWD is capable of supporting an ISS crew of six, but nominally supplies only half this crew size. The PWD design provides incremental quantities of hot and ambient temperature potable water to US food and beverage packages. PWD receives iodinated water from the US Water Recovery System (WRS) Fuel Cell Water Bus, which feeds from the Water Processing Assembly (WPA). The PWD removes the biocidal iodine to make the water potable prior to dispensing. A heater assembly contained within the unit supplies up to 2.0 L of hot water (65 to 93 °C) every 30 min. During a single meal, this quantity of water supports three to four crewmembers' food rehydration and beverages. The unit design has a functional life expectancy of 10 years, with replacement of limited life items, such as filters. To date, the PWD on-orbit performance is acceptable. Since activation of the PWD, there were several differences between on-orbit functionality and expected performance of hardware design. The comparison of on-orbit functionality to performance of hardware design is discussed for the following key areas: 1) microbial contamination, 2) no-dispense and water leakage scenarios, and 3) under-dispense scenarios.

## Nomenclature

ADC	= Analog to Digital Converter
°C	= Degrees Celsius
CFU	= Colony Forming Units
EXPRESS	= Expedite the Processing of Experiments to the Space Station
H <sub>2</sub> O <sub>2</sub>	= Hydrogen Peroxide
I <sup>-</sup>	= Iodide
I <sub>2</sub>	= Iodine
ISS	= International Space Station
JSC	= Johnson Space Center
KSC	= Kennedy Space Center
LED	= Light Emitting Diode
MCC	= Mission Control Center
MCD	= Microbial Check Device
MOD	= Mission Operations Directorate
MPLM	= Multipurpose Logistics Module
OSO	= Operational Support Officer

---

<sup>1</sup> Project Manager, Crew and Thermal Systems Division, EC3, 2101 NASA Rd 1, Mail Stop EC3, Houston, TX 77058, and AIAA Member.

<sup>2</sup> Project Manager, Life Support and Cold Stowage, Engineering Science Contract Group, 2222 Bay Area Blvd, Houston, TX 77058.

- ORU = Orbital Replacement Unit
- PIP = Package in Place
- PPM = Parts per Million
- PWD = Potable Water Dispenser
- QD = Quick Disconnect
- STS = Space Transportation System
- SV = Solenoid Valve
- TIC = Total Inorganic Carbon
- TOC = Total Organic Carbon
- TOCA = Total Organic Carbon Analyzer
- ULF = Utilization Logistics Flight
- US = United States
- USOS = United States On-orbit Segment
- WPA = Water Processing Assembly
- VCM = Valve Control Module
- WRS = Water Recovery System

## I. Background

The ISS PWD primary requirement is to provide potable water to the ISS US crewmembers. The crewmembers use the potable water to rehydrate food and drink packages while aboard the ISS. The PWD, located on the ISS US Lab, receives 28 Vdc of power from EXPRESS Rack 6. The PWD dispenses potable water in 25 mL increments, starting at 25 mL up to 250 mL. The Water Recovery System (WRS) Fuel Cell Water Bus supplies the PWD with iodinated water and pressure (14.75 to 30 psig). The pressure from the Fuel Cell Water Bus allows PWD to dispense water; the PWD does not contain any pumps to facilitate dispensing. The PWD dispenses both hot and ambient water. The hot water dispenses from a different fluid line than the ambient fluid within PWD (see Fig. 1 and 2). The PWD receives iodinated water at the PWD inlet, where it flows the iodinated water through the PWD flow path to the Quick Disconnect (QD) 3 on the PWD Filter ORU. From here, the water flows through a deiodination filter that removes the iodine. The potable water then flows through a 0.2 micron filter to remove any bacteria from the water, exiting through QD5 and leaving the PWD Filter ORU. At this point, the water flows through one of two different flow paths for either hot or ambient dispense. If ambient dispense, the water flows through Solenoid Valve (SV) 5 and out through the PWD Needle; roughly 50 mL of tubing. If hot dispense, the water flows through the PWD Heater, which warms the potable water via 12 Kapton heater circuits (each circuit containing 3 heater strips). Three thermostats control each heater circuit. The hot, potable water exits via SV4 and out through the PWD Needle. The volume of the fluid line is roughly 2 L, comprised of the PWD Heater itself and an additional 500 mL in the tubing downstream of the heater.

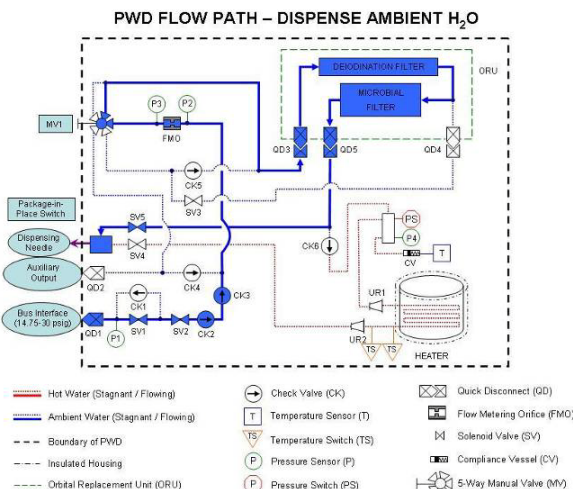

**Figure 1. PWD Ambient Flow Path**

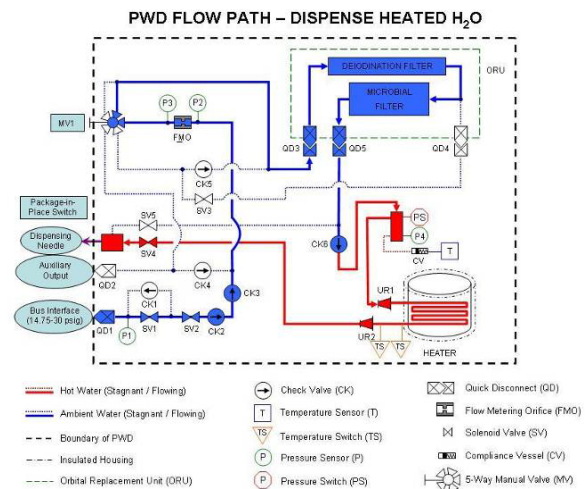

**Figure 2. PWD Heated Flow Path**

## II. PWD On-Orbit Issues

Major PWD On-orbit issues include the following:

- 1) Microbial contamination due to system stagnation during shipping, launch preparation, launch, and on-orbit installation.
- 2) Scenarios surrounding PWD leakage, resulting in inaccurate dispensing, etc.
- 3) Scenarios of the PWD under dispensing, resulting in less than desired water amounts.

### A. Microbial Contamination

The Kennedy Space Center (KSC) delivery date requirement for PWD was 6 months prior to the launch of STS 126, ULF2 (November 2008). This provided time for installation into the Multipurpose Logistics Module (MPLM). Once packing completed and the MPLM closed out, the PWD is installed into the cargo bay of the shuttle. The PWD remained stagnant between the time of delivery and activation on the ISS. The crew activated the PWD on-orbit at the end of November, by installation into EXPRESS Rack 6 and integration with the new WRS Racks, which also delivered on ULF2. The initial checkout of the integrated water systems began at the end of November 2008.

Initial checkout began with water quality analysis and microbiology tests on the new ISS water system, including water testing from the WRS Racks 1 and 2, Total Organic Carbon Analyzer (TOCA) and PWD. The TOCA has the ability to read and analyze the Total Organic Carbon (TOC) and Total Inorganic Carbon (TIC) in potable water supplies on ISS, giving an indication of food sources for bacteria growth. Neither TOCA or any other hardware on ISS, however, has the capability to read and analyze chemical water quality of a water source. Therefore, detailed water quality testing requires the return of on-orbit samples from the water systems to Earth. On-orbit capability does, however, allow crewmembers to test real-time samples for bacteria growth in water systems on ISS. The microbiological water quality testing capability resides in the Microbial Check Device (MCD), which allows crewmembers to flow the water source through a plated media, followed by 48-hr incubation and analysis for quality by counting the Colony Forming Units (CFU) within the water.

After a month of active on-orbit use, the crew tested the PWD for microbial contamination via the MCD. The results revealed a count of 85 CFU/mL within the ambient flow path of the PWD. The microbial water quality requirement limit for PWD is less than or equal to 50 CFU/mL for potable water. Any higher CFU requires a waiver and concurrence from the Space and Life Sciences community at Johnson Space Center (JSC). The crew also tested the hot flow path and auxiliary flow path of the PWD. The results revealed no bacterial contamination in either line (i.e., 0 CFU/mL).<sup>1</sup>

The engineers and scientists who designed the PWD worked to find the cause of the 85 CFU/mL test results. The PWD team theorized that problems began during the stagnation of the PWD during the 6 month delivery window. The team worked with the JSC Microbiology Lab to keep the system as clean as possible by using the lab recommendations for keeping the hardware clean during build and delivery to KSC. The PWD underwent preflight disinfection processes on the ground, which included flushing all PWD fluid flow paths with 20 to 30 ppm of iodine (I<sub>2</sub>), a biocide used to kill residual bacteria. The team used a solution of 6 percent hydrogen peroxide (H<sub>2</sub>O<sub>2</sub>) to disinfect the PWD Filter ORU, containing a deiodination filter, 0.2 micron filter, and stainless steel tubing (see Fig. 3). Once disinfected, the team filled the PWD with sterile deiodinated water and delivered it to KSC for stowage in the MPLM

Although the disinfection process appeared thorough at the time, the PWD project team determined some possible flaws with the disinfection process of the PWD Filter ORU and the PWD unit itself. Specifically, the dwell times used in both disinfection procedures for the PWD and the PWD Filter ORU was only 5 minutes. The PWD was disinfected with iodine, and the Filter ORU was disinfected with H<sub>2</sub>O<sub>2</sub>. During PWD troubleshooting for possible causes for microbial contamination, the JSC Microbiology Lab determined that the dwell times were

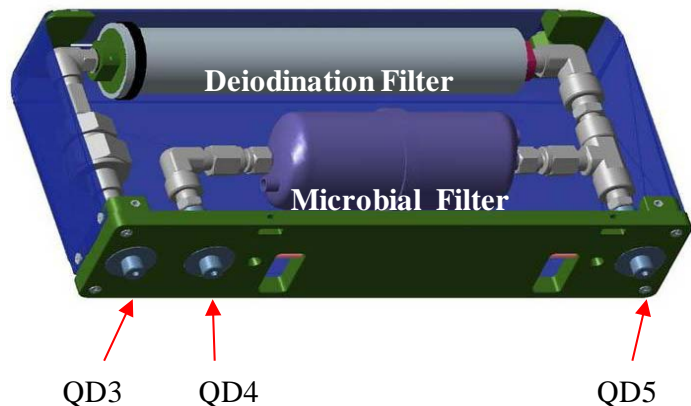
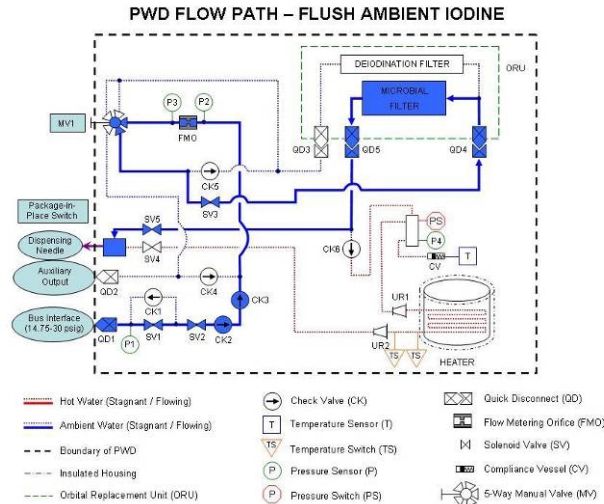

Figure 3. PWD Filter ORU

insufficient for both pieces of hardware, The Microbiology Lab recommended a minimum of 1 hr dwell disinfection time to achieve a successful disinfection. Since the PWD flight unit will not be reprocessed, this realization was too late. However, the team modified the applicable PWD Filter ORU process procedures to correct this issue for future flights. The PWD Filter ORU is delivered roughly every 8 months due to life time expiration.

While these theories explained the root cause of the microbial contamination within the PWD, the crewmembers still required immediate remediation, as ISS only had one of two potable water sources available. With the PWD unfit for crew consumption, they relied upon the Russian potable water source. The PWD team suggested a variety of remediation options to swiftly accommodate the crew and ISS Program's needs. The quickest and most affordable solution was to flush iodinated water from the WRS Fuel Cell Water Bus into the PWD, using the PWD Flush Iodine Mode, on January 7, 2009 (see Fig. 5). The PWD design included this mode in order to have the capability to flush biocidal, iodinated water (1 to 4 ppm  $I_2$ ) into the PWD, bypassing the PWD Filter ORU Deiodination Filter by going in through QD4. The flush continues through the Microbial Filter and downstream of the ambient leg of the PWD. Nominally, the ambient leg does not show residual biocide in the water (see Fig. 4); it does in this mode, due to the Deiodination Filter bypass.



**Figure 4. PWD Flush Iodine Mode, Ambient**

Although this solution provides hope for remediation of the ambient leg of the PWD, the PWD team recognized potential issues prior to success. The first known issue was the JSC Microbiology Lab determination that the low amount of  $I_2$  (1 to 4 ppm) from the Bus was not capable of remediating a known contaminated system. This low concentration of  $I_2$  was only sufficient to maintain an already clean system. Additionally, the team knew prior to delivery of the PWD that  $I_2$  was not compatible with the Microbial Filter

**PWD - Test results from Ambient Leg water measurements**

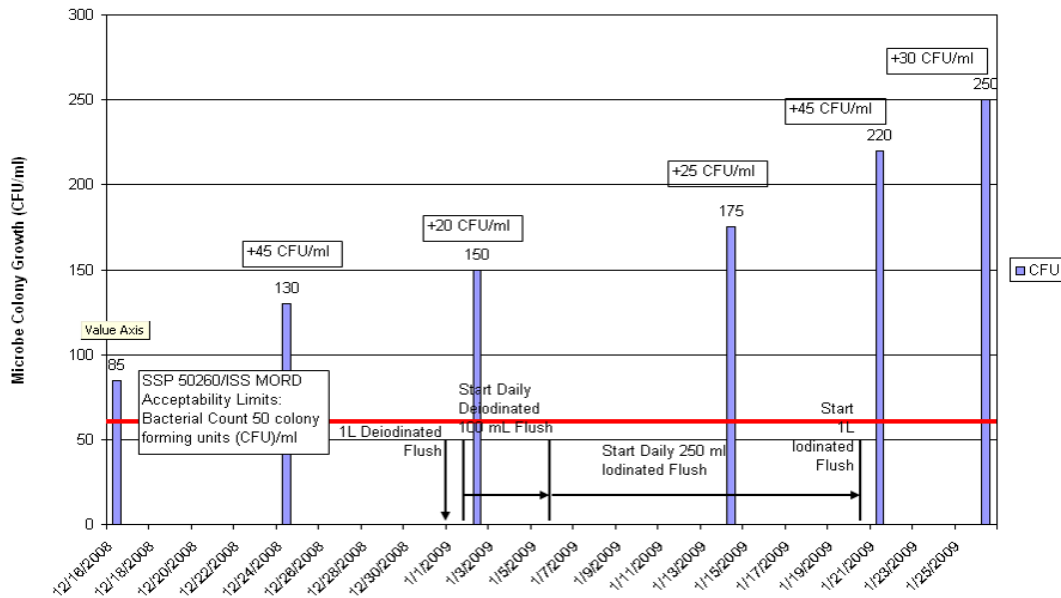

**Figure 5. PWD Flush Iodine Mode, Ambient**

material. The Microbial Filter media is a pleated Nylon 6,6, which absorbs the  $I_2$ , and desorbs iodide ( $I^-$ ).  $I_2$  is biocidal, while  $I^-$  is not; both are harmful from a crew health standpoint. Therefore, in the Flush Iodine Mode, the

PWD ambient leg (downstream of the PWD Filter ORU) did not see any biocide ( $I_2$ ) to remediate the possible contamination in that portion of the leg.

Despite the known issues, the Mission Operations Directorate (MOD) and the PWD team tried the flush option, as it was the quickest and most cost-effective solution to the PWD contamination issue. After the Flush Iodine Mode took place, the crew ran another MCD microbial test, which revealed yet another increase in microbial growth. The Flush Iodine Mode did nothing to help remediate the PWD contamination issue (see Fig. 5). This method of remediation failed because of a low concentration of iodine, in addition to the possibility of a iodine-resistant bacterium contamination.

The PWD team worked on more invasive contamination solutions, given the unsuccessful results of the Flush Iodine Mode (250 mL and 1L flushes). The PWD needed a stronger concentration of biocide for remediation. The team considered alternative chemical concentrations, such as  $H_2O_2$  and silver. Due to toxicity and safety issues, however, iodine remained the chemical of choice for remediation. The PWD team and the Microbiology Lab worked to determine the right amount of iodine concentration necessary to remediate the PWD, targeting 40 ppm of  $I_2$ .

The PWD team needed to determine the ideal delivery method of this high concentration of  $I_2$  into the on-orbit PWD, including the design of supplementary tools required to carry out the task. The team decided to deliver the 40 ppm  $I_2$  in Teflon bags with a Luer lock interface, allowing the chemical to inject into the PWD Microbial Filter vent port via a Filter Flush Assembly (see Fig. 6 and 7). The basis for the choice of Teflon bags derived from the fact that these bags were previously approved by the NASA Materials Analysis and Fracture Control group for compatibility with high concentrations of  $I_2$ . The Filter Flush Assembly consists of a female Luer lock, which interfaces with the Teflon bag male Luer lock, and a female Swagelok at the other end with the ability to connect to the vent port of the PWD Microbial Filter, Fig. 8.

In order to ensure the  $I_2$  injection would be successful, the team needed to take into consideration the effects of high concentrations of  $I_2$  injected into the noncompatible filter media. Subsequently, the PWD team worked with the JSC Water Quality group to determine the amount of flushing required to completely clear out the residual  $I_2$  from the filter after injection. The JSC Water Quality group tested the Nylon 6,6 media with 40 ppm of  $I_2$  and determined that at least 10 L of water must flush through the Micro Filter in order to desorb the chemical from the filter media. These results were critical, since the Microbial Filter absorbs  $I_2$  and desorbs  $I^-$ , both of which are hazardous for crew consumption. The crewmember iodine ingestion limit is 0.02 mg/L of Iodine, either  $I_2$  and  $I^-$ .<sup>2</sup> The 10 L flush quantity derives from the filter ability to desorb  $I_2$  and  $I^-$  under the required crew consumption limits.

In the event that the Microbial Filter did not recover with the deiodinated water 10 L flush, the PWD team conceptualized a recovery backup plan. The PWD Tube Assembly (Fig. 9) was designed to replace the Microbial Filter within the PWD Filter ORU, if the filter was not fit for use due to the inability to desorb all the highly-concentrated  $I_2$ . The crew would only use the PWD Tube Assembly in worst case scenarios to recover the PWD, since removing the PWD Microbial Filter would mean that the water would no longer filter bacteria. Therefore, the PWD could still deliver water to the crew, but there would always be a risk of illness to a crew member



**Figure 6. Teflon Bag filled with 40 ppm  $I_2$**

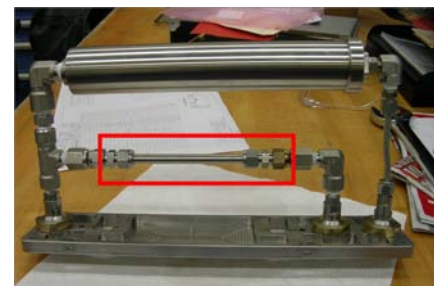

**Figure 7. Filter Flush Assembly**



**Figure 8. PWD Engineering Development Unit.**

(Mocking the iodine injection procedures into the PWD Filter ORU Microbial Filter vent port.)



**Figure 9. PWD Filter Tube Assembly (boxed in red)**

because the Microbial Filter would not be in line for a water dispense. To date, the PWD Tube Assembly has never been used.

The PWD Disinfection Kit consisted of the Teflon bag of 40 ppm I<sub>2</sub> solution; the PWD Filter Flush Assembly; the PWD Filter Tube Assembly; and three extra QD sterile caps for the PWD Filter ORU QDs. The QDs caps were delivered to place on the PWD Filter ORU QDs in case the Filter was removed from the PWD unit. The PWD Disinfection Kit launched on STS-119/15A in March 2009. The crew used the PWD Disinfection Kit (excluding the PWD Filter Tube Assembly) as planned during 15A docked operations in March 2009 (see Fig. 10). The initiative was a success and the microbial counts from the ambient leg of the PWD dropped from 250 CFU/mL to 0 CFU/mL, after the 10 L flush of water. Additionally, the PWD desorbed all of the I<sub>2</sub> and I from the microbial filter, making the effort a complete success. Since the use of the Disinfection Kit, the PWD continues to sustain low bacteria counts.



**Figure 10. On-orbit Use of Iodine Shock Kit**

### **B. No Dispense and Water Leakage Scenarios**

On June 6, 2009, the crew reported to Houston Mission Control Center (MCC) that the PWD stopped dispensing. One possible cause for a no dispense scenario includes a not fully active Package In Place (PIP) Switch. The PIP Switch resides behind the Beverage Adapter (see Fig. 11 and 12). The PIP Switch is a safety feature for the PWD, designed to prevent inadvertent dispense. The PIP Switch ensures that a food or drink package is in place before a dispense can occur (see Fig. 12). The PIP Switch activates via a plunger on the back of the Beverage Adapter, which fully extends when a food or drink package is in place, signaling the switch to allow a dispense to occur (see Fig. 13).

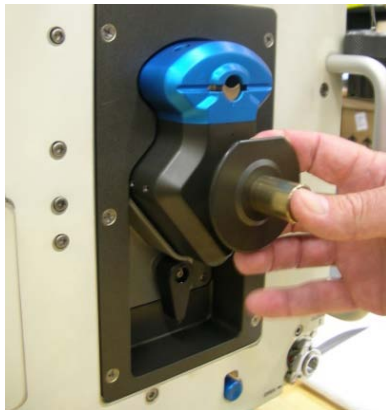

**Figure 11. PWD Beverage Adapter Extended**



**Figure 12. Behind the Beverage Adapter, PIP Switch**



**Figure 13. Back Side of the Beverage Adapter, Beverage Adapter Plunger (ORANGE)**

To validate the cause for the PWD malfunction, the team recommended that a crewmember use their finger to lightly press the PIP Switch, which would confirm that a dispense could occur with switch activation. The crewmember reported back that when they manually pressed the PIP Switch, the PWD began to dispense nominally. This verified why the PWD stopped dispensing, but did not establish a root cause for the Beverage Adapter Plunger failure to fully extend and actuate the PIP Switch. While the team continued to investigate the anomaly, the Operational Support Officer (OSO) recommended a temporary resolution to the problem. The OSO requested the crew add a small layer of tape on top of the PIP Switch to increase the area between the Beverage Adapter Plunger and PIP Switch. This would allow the plunger to make contact with the switch and actuate a dispense (see Fig. 14). This temporary workaround allowed the crewmembers to continue to use the Beverage Adapter nominally, while troubleshooting continued on the ground.

Although the temporary workaround was a good short-term fix, team concerns remained regarding the untested and unknown stresses induced on the PIP Switch, due to the off-nominal configuration of the layer of tape on the switch. The team requested a stress analysis to verify that the tape configuration on the switch was safe for continued use. The stress analysis found that the life of the PIP Switch potentially reduced from 1,000,000 cycles to less than 5000, if the switch continued in this off-nominal configuration. The PWD team created instructions for tape removal and a return to nominal switch configuration, while continuing to research the length of the Beverage Adapter plunger more closely.

On July 3, 2009, during the Beverage Adapter Plunger investigation, the crew reported to Houston MCC that the PWD Package Insert Port appeared rusty (see Fig. 15) and that the Beverage Adapter Slide Assembly was sticking (see Fig. 16). The crew took apart the Beverage Adapter Assembly on July 4, 2009, finding a water leak within the adapter. The crew also found apparent food debris or possible corrosion around the capture pins on top of the Slide Assembly within the Beverage Adapter Assembly (see Fig. 17). The PWD team instructed the crew to wipe down that area of the assembly with Povidone Iodine wipes to remove as much residual debris as possible.



**Figure 14. Behind the Beverage Adapter (PIP Switch with Tape)**



**Figure 15. On-orbit photo of PWD Package Insert Port with Food Residue/Corrosion within the Beverage Adapter the PIP Switch with Tape**

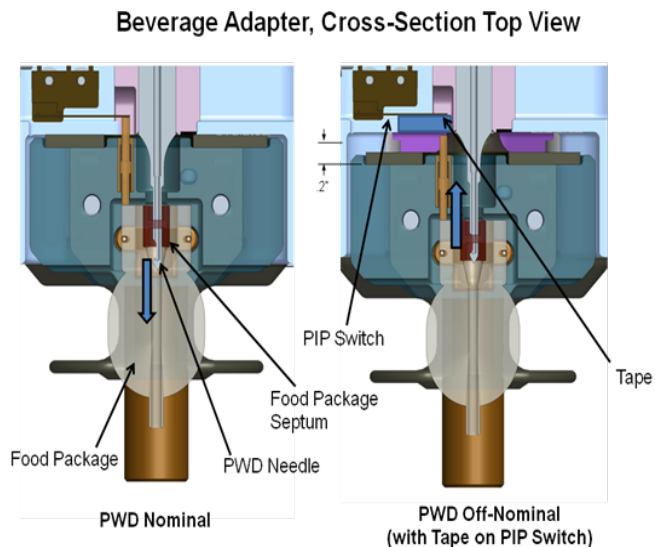

**Figure 16. Beverage Adapter Opened, Showing the Slide Assembly (RED)**



**Figure 17. Precleaning (left) Postcleaning (right): On-orbit Photos of the Food Residue/Corrosion on the Slide Assembly Internal to the Beverage Adapter**

The PWD team determined that a water leak from the dispense point of the Needle was back-flowing into the interior of the Beverage Adapter (see Fig. 18). The off-nominal configuration of the tape on the PIP Switch like exacerbated this scenario. The tape on the switch did not allow the PWD food and/or drink packages to seat properly within the Beverage Adapter, leaving a small gap where the Needle did not fully insert into the food or beverage package (see Fig. 18). With this understanding of the water leak within the Beverage Adapter, the team finalized the procedure to return the PWD to the nominal configuration. The procedure tasked the crew to lubricate the Beverage Adapter Plunger with Braycote 601 and remove the tape from the switch. Lubricating the plunger allowed it to loosen enough to fully extend and actuate the PIP Switch to activate a dispense. The crew performed the tasks successfully. The root cause for the plunger not fully extending, however, remained undetermined.



**Figure 18. Beverage Adapter Cross Sectional View, Leakage Path (blue arrow)**

On July 15, 2009, a few days after the PWD returned to nominal configuration, the crew called to Houston MCC to report that they continued to notice the Beverage Adapter Assembly sticking; they suspected the issue was still leakage. The PWD team advised the crew to open up the Beverage Adapter and clean it every 2 to 3 days to remedy the stickiness and residue. This cleaning resulted in a side effect. The Beverage Adapter was not designed to handle repetitive

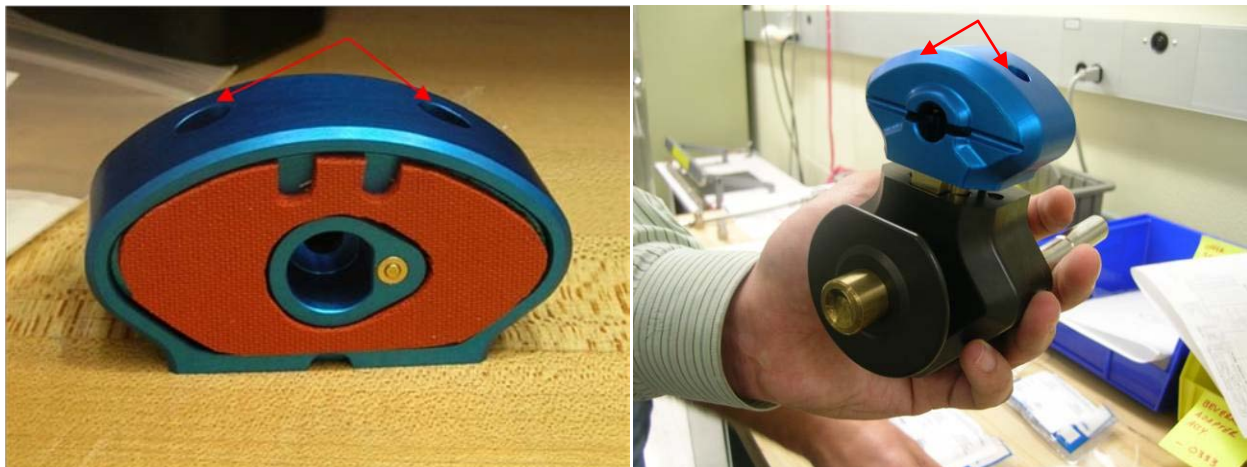

**Figure 19. Helical Insert location (RED)**



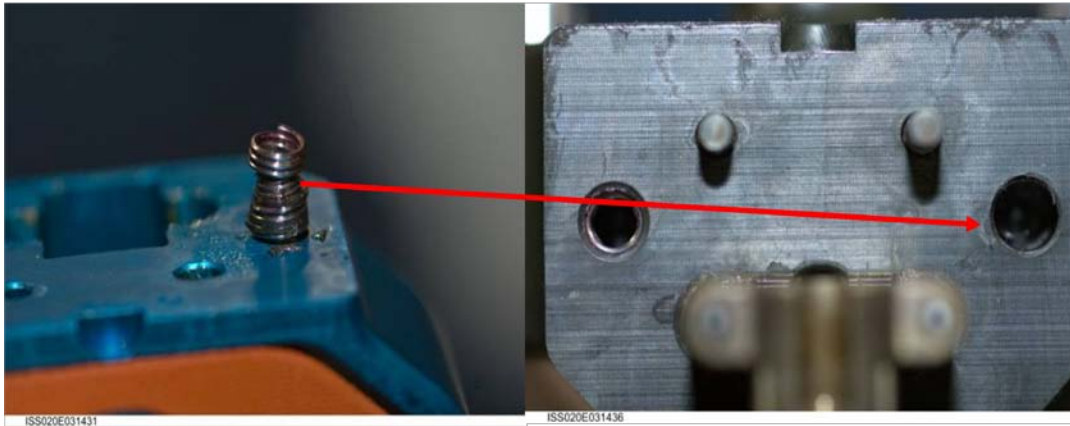

**Figure 20. Stripped Helical Insert from the Beverage Adapter**

disassembly for cleaning, as it was not foreseen that a leak would occur in this area. On August 24, 2009, due to repetitive off-nominal cleaning of the Beverage Adapter, one of the two locking inserts failed on orbit (see Fig. 19 and 20). Over-torque during Beverage Adapter reassembly stripped out the helical insert. The Beverage Adapter can function with one fastener. If the crew damaged the other insert, however, nothing would hold the two pieces of the Beverage Adapter together. The PWD team quickly engineered short- and long-term solutions to address the problem. The short-term solution recommended the crew to wrap Kapton tape around the parameter of the Beverage Adapter. The recommended long term solution was for the PWD team to redesign and deliver a new Beverage Adapter capable of withstanding repetitive cleaning. Within 3 months of the initial request, the redesigned Beverage Adapter was delivered to the ISS on ULF3.

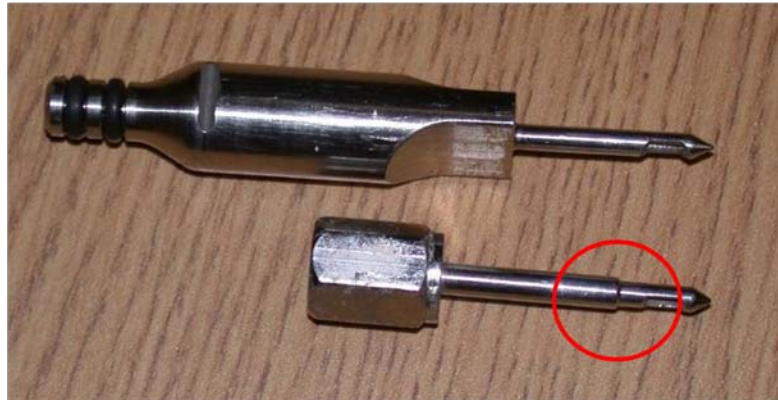

**Figure 21. (Top) PWD Needle, (Bottom) Shuttle Galley Needle**

The leak issue is still undergoing investigation by the team. The team's inability to duplicate the leak may stem from the zero gravity atmosphere in which the leak occurred. The PWD Needle design is one of the possible causes for the leak. The team found that the Shuttle Galley Needle design differed from the PWD Needle design by a small shoulder feature found on the Shuttle Galley Needle. (see Fig. 21). It is believed that the shoulder on the Shuttle Galley Needle provides an additional sealing surface at the septum interface on the food/drink package, which prevents potential water backflow. Since the team could not replicate the leakage found on orbit, the PWD team could only replicate the Shuttle Galley's Needle design, but could not verify that the new Needle design fixed the leakage problem. The newly designed PWD Needle, matching the Shuttle Galley Needle, was delivered to ISS on 20A, February 2010. Once the redesigned PWD Needle is on orbit, the team will assess whether the theory of the shoulder resolves the leak issue with the Beverage Adapter.

### C. Under-Dispense Scenarios

After several months of nominal use, on-orbit crewmembers began to observe that the PWD was not accurately dispensing the proper amount of water during use. In mid-July 2009, ISS occupant Dr. Michael Barrett filmed an on-orbit calibration study experiment on the PWD. This experiment recorded the results of PWD dispenses for quantities at 25, 50, 75, and 250 mL. The test results showed dispense quantities of approximately 60 percent of the requested amount. With the under-dispense scenario confirmed by video, a failure investigation began to determine root cause for the under-dispense scenario.

Root cause analysis indicated that a low dispense volume is a function of one of two scenarios (see Fig. 22). Possible causes follow: 1) The system pressure is lower than expected at the inlet or there is an internal pressure drop to the PWD; and/or 2) there is a malfunction within the flow control of the PWD System electronics. The low system pressure could come from the inlet and/or the increased pressure drop within the PWD Flow Loop or the

PWD ORU Filter. The malfunction in the electronics could derive from within the PIP Switch, watchdog timers and/or the valve control module or volume control module.

The PWD team began the troubleshooting investigation by analyzing the system pressure and comparing it to the known nominal inlet pressure of 15 psi (692 mL/min flow rate). The on-orbit calculation of flow rate was around 240 mL/min. This indicated an inlet pressure below 8 psi to result in such a low flow rate. Actual on-orbit WRS Fuel Cell Water Bus data indicated a pressure of 19 psi, which meant an improbable inlet pressure root cause. A pressure drop increase due to a possible obstruction is a more likely root cause, due to the small orifice of the needle and the close proximity to possible food contamination. An obstruction causing an increase in pressure drop across check valves or the solenoid valve is an unlikely root cause, since the diameters are 3 to 4 times greater than that of the needle diameter.

The most likely root cause for the increase in pressure drop is due to an obstruction within the Filter ORU Assembly. The under dispensing occurred after approximately 8 months of filter use. This was the same Filter ORU that the crew used the Disinfection Kit on in March 2009. The 0.2 micron microbial filter can trap debris and even air, which means the PWD may become obstructed over time, causing blocked water flow and an under-dispense scenario.

A fault tree analysis of the PWD Flow Control electronics (see Fig. 23) shows an early termination of the water flow cycle and a reduced dispense volume. Dr. Barrett’s video recording of the experiment allowed the PWD team on the ground to observe the behavior of the PWD LED lights. Through this observance of how the PWD LED lights responded during dispense, the engineers determined the probable/improbable failures within the Flow Control electronics.

Engineers noticed at the end of every dispense cycle, both of the PWD LEDs (see Fig. 24) stopped blinking and went to steady-state prior to the PIP Switch release. This showed a watchdog timer override, a clear indication that the problem was not an early release of the PIP Switch. Observing the start and stop of the blinking LEDs during Dr. Barrett’s 250 mL dispense, the lapse time was approximately 30 seconds. The PWD watchdog timer is set at a fixed rate of 500 mL/min, which corresponds to the behavior of the LED lights going to steady state at the end of a dispense. The LED observation eliminated the volume control watchdog early timeout event as a root cause failure. The same manner of PWD LED observation indicated the improbability of an independent watchdog early timeout as a root cause, because the controls would not have functioned. (I get it, but this is a lot to digest. You may want to add clarification for other readers.)

Another possible cause included a Valve Control Module (VCM) malfunction. The VCM should only change state in response to a command from the watchdog time or volume control module. If the VCM malfunctions, an inconsistent dispense volume results, since the module does not have its own timer to consistently terminate a cycle. Data showed the dispense at consistently 60 percent less than the nominal dispense volume, ruling out the probability of a VCM malfunction and thereby indicating a nominal watchdog abort.

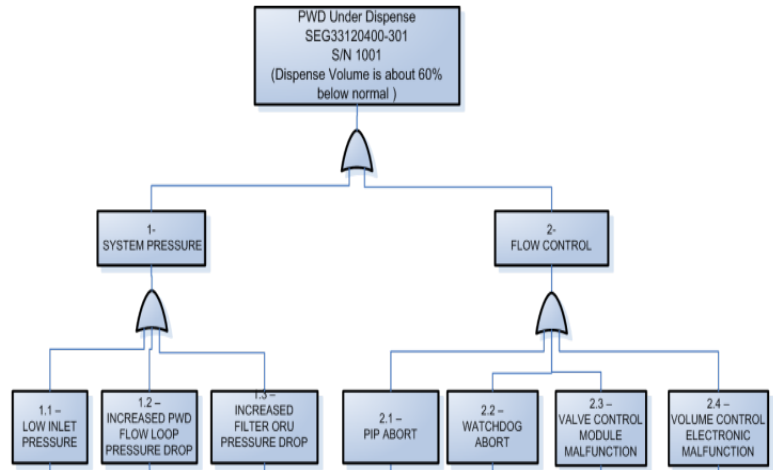

Figure 22. Root Cause Under Dispense Fault Tree

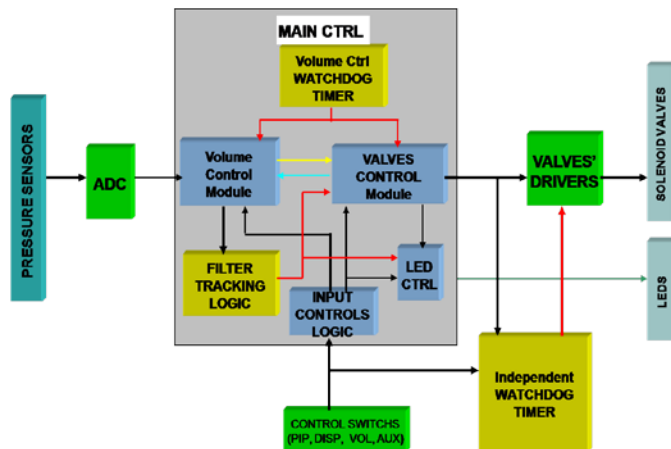

Figure 23. PWD Flow Control Electronics

The final leg of the fault tree analysis to be considered was the volume control module (VCM), a part of the Flow Control components. If the VCM fails, either the internal pressure sensor, the ADC, or the internal flow calculation logic failed. Failure of these components would result in one of the following: a low delta-pressure reading or a high delta-pressure reading. A low delta-pressure reading would result in a calculated flow rate lower than actual with a longer dispense time. The watchdog timer would abort the cycle with a higher than selected dispensed volume. A high-delta-pressure reading would result in a calculated flow rate larger than the actual rate, with a reduced dispense time. The dispensed volume would be lower, but the watchdog would not activate. Neither of these events occurred, pointing to the improbability of VCM failure.

### III. Conclusion

The facts presented in Dr. Barrett's experiment video of PWD dispense accuracy (the pressure data from the Water Bus, observed LED lighting responses, and dispensed volume), indicate that the most probable cause for the under-dispense failure of the PWD is an obstruction somewhere within the PWD system. There are indications of an obstruction within the PWD Filter ORU Assembly and a high probability of an obstruction within the PWD Needle. However, there is a still low probability that there is an obstruction within a check valve or solenoid valve. This obstruction condition can result from a combination of any of the above-listed probable causes.

The PWD team gave the crew several troubleshooting courses of action as solutions to the under-dispense issue: 1) Check the PWD System for obvious visual obstructions, including a pinched water hose; 2) check, clean, or replace the needle; and 3) replace the PWD Filter ORU. Although the under-dispense is a nuisance to the ISS crew, it is not a safety issue to date. The need to continue to dispense additional times to achieve the desired hydration is acceptable.

### Acknowledgments

We would like to thank Manuel Marico, Jacobs Technology and Max Musso, Jacobs Technology, for providing technical support during PWD troubleshooting activities.

### References

<sup>1</sup>SF24-09-124, dated October 14, 2009; Final Report Microbiological Analysis of Samples collected During the Initial 90-Day Checkout Period of the U.S. Water Recovery. NASA Johnson Space Center, Houston, TX 77058.

<sup>2</sup>SSP 50260 Rev D, ISS Medical Operations Requirements Document (MORD). NASA Johnson Space Center, Houston, TX 77058.

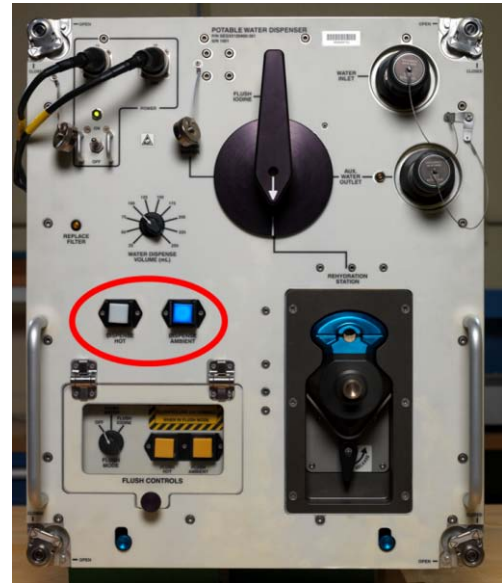

Figure 24. Front Panel of the PWD, LEDs (RED)