

Development of a Contingency Capillary Wastewater Management Device

Evan A. Thomas, Ph.D.¹

NASA-Johnson Space Center, Houston, Texas 77058

The Personal Body-Attached Liquid Liquidator (PBALL) is conceived as a passive, capillary driven contingency wastewater disposal device. In this contingency scenario, the airflow system on the NASA Crew Exploration Vehicle (CEV) is assumed to have failed, leaving only passive hardware and vacuum vent to dispose of the wastewater. To meet these needs, the PBALL was conceived to rely on capillary action and urine wetting design considerations. The PBALL is designed to accommodate a range of wetting conditions, from $0^\circ < \Theta_{adv} \sim 90^\circ$, be adaptable for both male and female use, collect and retain up to a liter of urine, minimize splash-back, and allow continuous drain of the wastewater to vacuum while minimizing cabin air loss. A sub-scale PBALL test article was demonstrated on NASA's reduced gravity aircraft in April, 2010.

Nomenclature

Θ_{adv} = advancing contact angle

I. Introduction

NASA's Orion Crew Exploration Vehicle (CEV) will require efficient use of mass, volume, energy and consumables given the smaller habitable volume and longer duration missions for which it is planned compared to the Space Shuttle Program. One system that will be adapted is the human waste management subsystem. This hardware is responsible for the collection and disposal of human liquid and solid waste, including urine.

The Space Shuttle and the International Space Station both currently use rotary fan separators for humidity condensate and wastewater separation. The rotary fan separators process high air to liquid flowrate ratios by spinning the multiphase flow against a bowl-like surface where pitot pumps pick up and transfer the more dense liquid. The liquid phase is dumped or processed, and the air phase is returned to the cabin. Unfortunately, the rotary fan separators have been shown to be prone to failure and fouling. The tight tolerances and small orifices do not respond well to biofouling or scaling, and in general the rotating nature of the equipment increases the likelihood of failure. The separators have failed numerous times, occasionally putting a severe strain on the mission and crew. These failures were often linked to wastewater fouling^{3,4}.

The current CEV design includes a rotary fan separator, but also may allow for a contingency wastewater removal device, assuming the rotary fan separator has failed. The current baseline contingency device is the International Space Station Urine Collection Device (UCD), shown in Figure 1. However, these UCDs are single use items, which will require significant consumables and are not considered particularly comfortable by female crewmembers. Instead, this paper presents a proposed capillary-based contingency urine removal system, the Personal Body-Attached Liquid Liquidator (PBALL), and preliminary sub-scale testing of this concept.

In the contingency scenario, the airflow system is assumed to have failed, leaving only passive hardware and vacuum vent to dispose of the wastewater. To meet these needs, the PBALL was conceived to rely on capillary action and urine wetting design considerations. The PBALL is designed to accommodate a range of wetting conditions, from $0^\circ < \Theta_{adv} \sim 90^\circ$, be adaptable for both male and



Figure 1. ISS Urine Collection Device

¹ Aerospace Engineer, Crew and Thermal Systems Division, NASA Johnson Space Center, 2101 NASA Parkway, Houston, TX 77058 Mailcode EC3, AIAA Member Grade for first author.

female use, collect and retain up to a liter of urine, minimize splash-back, and allow continuous drain of the wastewater to vacuum while minimizing cabin air loss.

II. Background

A. Microgravity Fluid Management

Development of spacecraft life support hardware over the past few decades has focused primarily on microgravity applications, with sophisticated designs usually constrained by limitations of volume, mass and power. In particular, for 2-phase gas/liquid separation in microgravity, centripetal acceleration or capillary action is used to remove liquids without the aid of gravity-driven buoyancy. These systems have often been prone to failure due to fluid fouling caused by biological reactions or mineral scaling, which can clog mechanical systems and degrade the performance of capillary-based systems. In turn, these failures can cause increased maintenance cost and overall crew labor burden.

In a microgravity environment, separation of immiscible fluids (i.e. gas and liquid) does not occur naturally, as it does on Earth due to buoyancy. In such situations, surface tension and wetting forces become the dominant influence on the liquid behavior. Capillary action is regularly used for the control of liquids in various spacecraft systems, such as propellant and cryogen management or in thermal fluid loops for temperature control⁵. Large length-scale capillary systems such as these tend to exploit container geometry and fluid properties to passively transport fluids to desired positions for a variety of purposes. Thus, the shape of the container can serve as a pumping mechanism that does not rely on moving parts. Unfortunately, such methods have only been confidently established for well characterized systems with favorable wetting conditions. Generally, these systems work best when the advancing contact angle Θ_{adv} is reliably low (Figure 2), yielding a high degree of capillary pumping. This key design parameter, which is the angle formed between the advancing liquid interface and the solid surface as it moves along, is governed by the various surface energies and the geometry of the solid surface⁶. The lower Θ_{adv} the greater the degree of affinity the liquid has for the surface, leading to an increased spontaneous wicking potential. Any changes to the surface properties, including fouling, can affect this process.

Systems in microgravity, such as propellant tanks, are often designed to take advantage of capillary forces and passively drive fluids in desired directions. For example, Figure 3 shows a sketch of a liquid in a wedge where the pressure drop across the fluid surface can drive the fluid along the corner. The pressure drop can be represented as⁷:

$$P_{\infty} - P_2 = \frac{\sigma}{R} = \frac{\sigma}{h} \left(\frac{\cos \theta}{\sin \alpha} - 1 \right) \quad (1)$$

where P_{∞} is the atmospheric pressure, P_2 the pressure at the interface, σ the surface tension of the liquid, R the principle interface radius of curvature, θ the contact angle of the liquid with the solid, α the half-angle of the interior corner, and h the height of the liquid as measured from the corner vertex. In Equation 1 when $\alpha < 90^\circ - \theta$ (and in the absence of significant body forces such as gravity, vehicle acceleration, vibrations or inertia) an under-pressure ($P_{\infty} > P_2$) in the liquid arises such that any gradients in the meniscus height along the corner will result in a spontaneous redistribution of fluid along the corner until such gradients are eliminated. Similarly, a corner channel with a changing α will ensure that the liquid will pump along the corner in the direction of decreasing capillary pressure⁷.

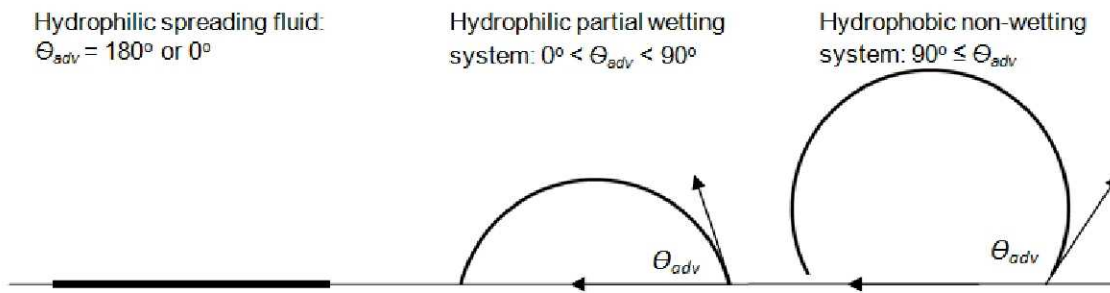

Figure 2: Illustration of advancing contact angle (Θ_{adv}) (adapted from¹)

In contrast to state-of-the-art mechanical approaches, it is anticipated that passive capillary driven liquid phase separation is feasible in place of active rotary separators for wastewater applications, where the wetting and fouling characteristics can vary widely. Thomas and Muirhead² observed that certain aspects of wastewater fouling can improve wetting characteristics. They found that although vacuum drying and large defects tended to increase Θ_{adv} , crystal growth and biofilm growth actually lowered Θ_{adv} . They also noted that the use of pretreatments generally increased Θ_{adv} . These trends indicate that promotion of wastewater fouling may be exploited to significantly decrease Θ_{adv} and thereby improve performance of capillary-based fluid management systems.

In a related study, a passive capillary-driven ‘static phase separator’ was developed and tested in a reduced-gravity environment to demonstrate successful air/liquid separation under highly variable wetting conditions⁵. When the system was operated within design specifications, it achieved 100% separation in nearly 100% of the tests performed, and with fluids of widely varying contact angles. The sub-scale prototype demonstrated several key design features:

- Centrifugal motive gas flow can be used effectively to force droplet coalescence
- The bulk fluid flow may be controlled by either wicking in the case of favorable wetting ($\Theta_{adv} \ll 90^\circ$) or air drag in the case of poor wetting ($\Theta_{adv} \sim 90^\circ$) —the same geometry can serve both limits
- Capillary forces act to ‘contain’ the liquid in both cases
- Liquid carryover is minimized by pinning edges in the case of favorable wetting or tortuous paths in the case of poor wetting

When contact angles are large, capillary wicking rates are reduced below the input liquid flow rate and the capillary force actually resists fluid motion. In this case the bulk liquid will accumulate locally until liquid momentum overwhelms the capillary force and dynamic pressure is sufficient to direct the liquid to its desired storage location. Capillary pinning effects in this region then serve to contain the liquid for further processing. In general, geometry-based design considerations based on this principle can be used to improve the operational reliability of capillary-based microgravity fluid management systems.

B. Fouling

Biofouling is a phenomenon through which microbial growth in a water solution attaches to wetted surfaces within the system. Due to the self-contained and continuous functionality typical of spacecraft water management systems in particular, the detrimental effects of biofouling pose well recognized design and operational challenges. Testing conducted at NASA-Marshall Space Flight Center indicated that microbiology contributed to corrosion of an aluminum alloy used in spacecraft water recovery systems⁸. The study also concluded that once biofilms form in a water recovery system they are “extremely difficult to remove” without methods that are destructive to the hardware. If iodine is added to the potable water system to prevent microbial growth, it must subsequently be removed before drinking due to crew health concerns—a unit operation that further increases system complexity⁹. Designing systems that are less susceptible to biofouling offers only one potential solution to these concerns.

Another form of wastewater fouling is mineral scaling. Scaling occurs as inorganic precipitates form when certain ion concentrations in solutions exceed their solubility limits and create solid salts. These salts then precipitate onto surfaces. Because water management systems are often exposed to fluids with high salt concentrations (i.e. urine), the prevention of scaling must be addressed. Scaling can be avoided by pretreatment or by careful design and operation of the water management system.

The use of oxidizing pretreatment chemicals for spacecraft wastewater is intended to prevent urea hydrolysis and the subsequent biofilm and precipitate formation that tends to foul and clog hardware such as rotary fan separators, vacuum orifice, or water recovery systems. In contrast, the absence of pretreatment chemicals likely results in an increased prevalence of

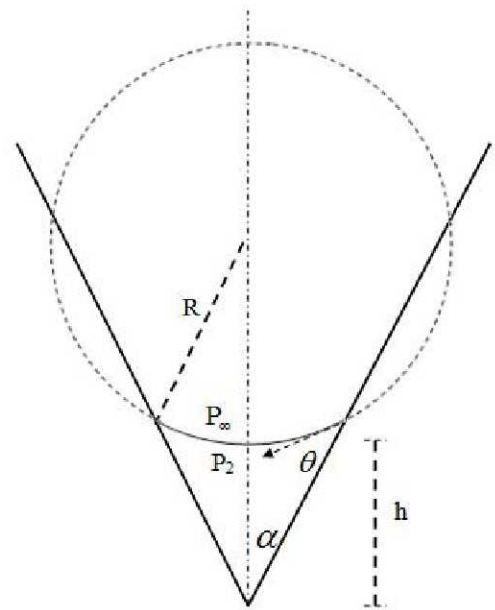

Figure 3: Liquid in a wedge

biofilm formation and small crystalline growth, which has been shown to significantly lower the contact angle by up to 44° with 95% confidence². This response can be utilized by design to increase the performance of a capillary-based wastewater management system. Consequently, an alternate design strategy coinciding with the use of a capillary-based system might be to eliminate the need for pretreatment chemicals intended to prevent fouling, and deliberately allow wastewater fouling to occur in the liquid management system. The operational implications of employing this approach are discussed below.

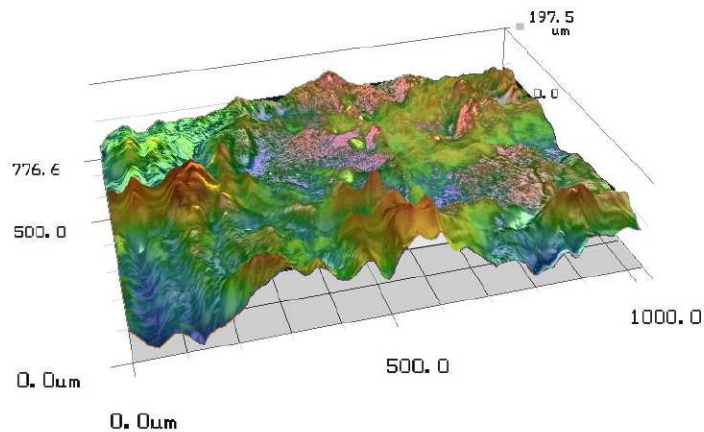

Figure 4: Wastewater fouling profile image²

While incorporating a wastewater management system that does not require pretreatment chemicals would undoubtedly be beneficial from an operational and logistics perspective, the effect of intentionally allowing biofilm formation on associated systems that are prone to clogging would still need to be considered. As a case study, the Space Shuttle currently uses a 0.87 cm internal diameter pipeline linking the wastewater storage tank to the vacuum dump orifice, approximately 0.14 cm in diameter. Between the wastewater tank and the vacuum orifice is a composite foam filter, with the smallest layer having a mean pore size of 300 μm , yielding a clean filter pressure drop of 0.1 psid. During at least one flight anomaly, decreased flow was observed through the wastewater dump line. A subsequent investigation suggested that either bubble formation or precipitate fouling caused the decreased flow rate¹⁰. If this conclusion is correct, it is certainly important to consider the likelihood of the intentional fouling layer resulting in clogging of other parts in the system. Part of this concern arises from the potential for biomass to break off and into the liquid stream. As the example of a surface with relatively deep features in Figure 4 illustrates, however, the thickness of waste water fouling layers is generally less than 300 μm , and these results suggest that the fouling layer is unlikely to grow to a depth that would slough off and clog downstream hardware².

Thus, while clogging of the wastewater dump line and wastewater storage tank is unlikely, care should be taken to appropriately size the dump line filter to avoid clogging it or any small downstream component such as a vacuum orifice. The foam filter is specifically designed to filter particulates that arise in spite of pretreatment chemicals, i.e. clothing fibers or hair. Amorphous deposits are likely a consequence the amorphous crystalline or biofilm formations and must be collected by the filter. It seems feasible to modify the foam filter to include a lower density stage to trap and remove sticky amorphous deposits, without causing a dramatic increase in the pressure loss across the filter or allowing breakthrough of the contaminants.

The Space Shuttle air return line includes both an odor and a bacterial filter. The air flow returned from a capillary-based liquid-air separator would likely have a higher odor and bacterial burden, but could likewise be filtered before returning to the cabin. Of greater concern is the probable odor and bacteria emitted from a wastewater input funnel caused by biofouling in the absence of pretreatment. However, simple operational rules could be put in place to minimize these undesirable effects as well. For example, simply capping the interface when not in use would trap odors, similar to how the Apollo crew capsule urine dump line was used. When operated, the air fan assist would draw cabin air through the system and minimize the potential for contaminants to escape. Additionally, the urine funnel would be interchangeable and cleaned between uses, as current operational protocols specify. Within these imposed constraints, the absence of pretreatment chemicals should not create an added odor and bacterial burden in the spacecraft.

III. Design

The PBALL device is composed of a crew interface, a void volume to retain the bulk liquid, and a capillary vane structure that serves to draw the urine away from the void volume and towards the vacuum drain port. The vane structure (resembling a tapering stack of ‘waving fans’) utilizes capillary wedge geometry to collect, contain and dispose of the wastewater. Figure 5 shows the vane structure design for PBALL, wherein a large void volume is presented to the incoming wastewater stream to minimize pinning events. The vane structure becomes denser downstream and reduces the interior angle of the vanes. This provides capillary pumping for wetting conditions and generally allows for concentration of the bulk liquid with passive displacement of the air. In poor-wetting

conditions, the momentum of the liquid stream forces the liquid downstream. Spurious perturbations to the system promote capillary pumping. Only a single vane continues to the liquid exit port providing capillary communication to the bulk liquid without extensive viscous and pinning forces.

The PBALL design demonstrates application of a number of fundamental capillary-driven principles described in¹¹, namely:

- Collection of bulk fluid via capillary geometries (for favorable wetting the capillary uptake rate exceeds the input rate) and liquid momentum (for unfavorable wetting, when the capillary uptake rate is lower than the input rate the device relies on liquid inertia and capillary containment to capture and separate the fluid phases)
- Containment of bulk fluid by capillary force
- Minimization of carryover or splash by pinning edges
- Promotion of beneficial fouling by avoiding pretreatment chemicals

IV. Testing

Testing of the PBALL concept was conducted on NASA's 727 Reduced Gravity aircraft with a sub-scale test article. In such dynamic reduced-acceleration environments g-levels are typically on the order of 0.1 to 0.001g_o. Therefore, the critical Bond number must be met to ensure that background accelerations do not destabilize the liquid system⁵. The Bond number is a dimensionless comparison of the relative magnitude of gravitational and capillary forces. When $Bo \gg 1$ gravitational forces dominate. When $Bo \ll 1$, capillary forces dominate¹. Adapting the Bond number for the PBALL design

$$Bo_{cr} = \frac{\Delta\rho g RL}{\sigma} < 1 \quad (2)$$

where $\Delta\rho$ is the difference in the density between the gas and liquid, and R and L are the radius and length of the PBALL test article critical capillary geometries⁵. In a similar way, a critical Weber number condition must also be met to reduce the confounding effects of inertia,

$$We_{cr} = \frac{\Delta\rho V^2 R}{\sigma} < 3 \quad (3)$$

where V is a characteristic velocity of the flow. An experimental reduced-gravity apparatus was developed that allowed for circulation of a test liquid through a sequence of test articles. All tests were conducted with DI water as an ersatz for wastewater with contact angle $\theta > 80^\circ$. Some test articles also used 200 proof Ethanol as an ersatz for urine with $\theta \sim 10^\circ$. The sub-scale flow rates used were approximately 20 ml/min liquid flow rate, to allow for examination of capillary phenomenon in the test article during ~30 second reduced gravity parabolas, in a test article with a containment volume of approximately 20 ml.

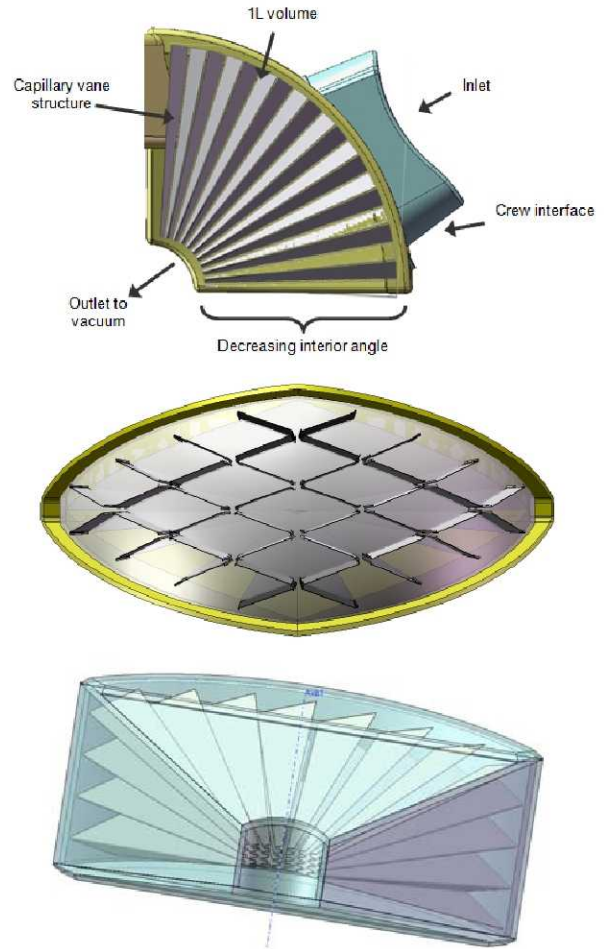

Figure 5. PBALL illustrations

A 727 reduced gravity testing rig was developed to test each SPS sub-scale test article. The test rig is shown in Figure 6. The liquid line was fed by graduated syringes, and the liquid drained and carried over was collected at the end of each test point in separate syringes. The liquid flow path is shown in Figure 7.

The subscale test article tested on the 7272 is shown in Figure 8. This test article uses a single set of capillary vanes, and liquid is introduced through a nozzle to either the acute or obtuse angles of the vanes, depending on which nozzle input is selected. The vanes are perforated to allow for liquid cross-talk. The test article is constructed entirely of acrylic to allow for flow visualization.

NOTE TO REVIEWER: This testing will be conducted on the 727 in April 2010. This draft will be revised shortly after the testing to include testing results.

V. Conclusion

The PBALL concept is conceived as a contingency wastewater removal device for microgravity spaceflight that relies on capillary geometries to direct liquid inventories without the benefit of air flow or rotating equipment. A subscale test article was flown on NASA's reduced gravity aircraft. Testing indicated.... Based on these results, ... **NOTE TO REVIEWER: This testing will be conducted on the 727 in April 2010. This draft will be revised shortly after the testing to include conclusions.**

Acknowledgments

The author thanks contributions from Prof. Mark Weislogel, Dr. John Graf, Jeff Stewart, Christie Carlile, Avery Bang, and Michael Brackney.



Figure 6. PBALL reduced gravity testing rig

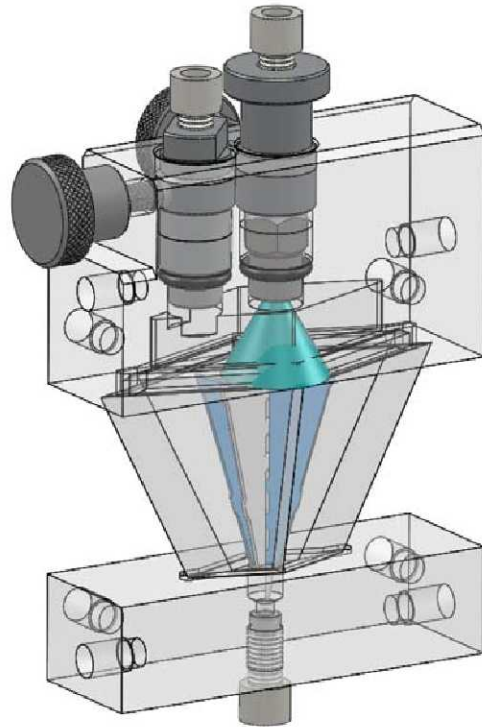

Figure 8. PBALL reduced gravity sub-scale test article

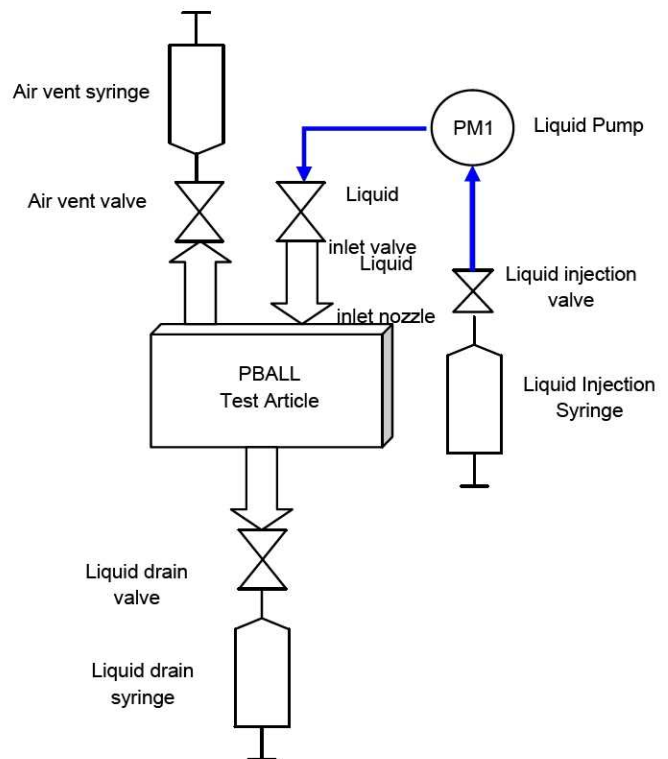

Figure 7. PBALL reduced gravity testing rig flow loop

References

1. Dodge, F., *The New Dynamic Behavior of Liquids in Moving Containers*. 2000, San Antonio: Southwest Research Institute.
2. Thomas, E. and D. Muirhead, *Wastewater Fouling Impact on Capillary Contact Angle*. *Biofouling*, 2009. **2**(5): p. 445-454.
3. Johnson, J., *Shuttle OPS V08-Waste Collection System*. 2002, NASA-Johnson Space Center: Houston.
4. Puttkamer, J. *ISS On-Orbit Status 05/21/08*. International Space Station Daily Report 2008 [cited 2008 November 24, 2008]; Available from: http://www.hq.nasa.gov/osf/iss_reports/reports2008/05-21-2008.htm.
5. Weislogel, M., E. Thomas, and J. Graf, *A Novel Device Addressing Design Challenges for Passive Fluid Phase Separations Aboard Spacecraft*. *Microgravity Science and Technology*, 2009. **21**(3): p. 257-268.
6. Quere, D., *Wetting and Roughness*. *Ann Rev. Mater. Res.*, 2008. **38**(23-43): p. 71-99.
7. Weislogel, M.M., *Capillary Flow in an Interior Corner*, L.R. Center, Editor. 1996, NASA.
8. Obenhuber, D., T. Huff, and E. Rodgers, *Microbial Biofilm Studies of the Environmental Control and Life Support System Water Recovery Test for Space Station Freedom*, in *ICES*. 1991, SAE: San Francisco, CA.
9. NASA-JSC, *Lunar-Mars Life Support Test Project: Phase III Final Report*. 2000, Crew and Thermal Systems Division.
10. Muirhead, D. and C. Verostko, *STS-116 Wastewater Dump Line In-Flight Anomaly Investigation: Experimental Assessment of the STS-116 Wastewater Collection and Effects on Dump Line Subsystem* 2007, ESCG.
11. Thomas, E., M. Weislogel, and D. Klaus, *Design Considerations for Sustainable Spacecraft Water Management Systems*. *Advances in Space Research*, 2009. (**submitted**).