



US007599074B2

(12) **United States Patent**
Sun et al.

(10) **Patent No.:** US 7,599,074 B2
(45) **Date of Patent:** Oct. 6, 2009

(54) **GRATING ANGLE MAGNIFICATION
ENHANCED ANGULAR SENSOR AND
SCANNER**

(75) Inventors: **Ke-Xun Sun**, Stanford, CA (US);
Robert L. Byer, Stanford, CA (US)

(73) Assignee: **The Board of Trustees of the Leland
Stanford Junior University**, Palo Alto,
CA (US)

(*) Notice: Subject to any disclaimer, the term of this
patent is extended or adjusted under 35
U.S.C. 154(b) by 353 days.

(21) Appl. No.: 11/820,720

(22) Filed: Jun. 19, 2007

(65) **Prior Publication Data**

US 2008/0002197 A1 Jan. 3, 2008

Related U.S. Application Data

(60) Provisional application No. 60/815,098, filed on Jun.
19, 2006.

(51) **Int. Cl.**
G01B 11/14 (2006.01)

(52) **U.S. Cl.** 356/614

(58) **Field of Classification Search** 356/614-624
See application file for complete search history.

(56) **References Cited**

U.S. PATENT DOCUMENTS

4,330,212 A 5/1982 Miller
4,804,270 A * 2/1989 Miller et al. 356/508

5,073,918 A 12/1991 Kamon
5,359,409 A * 10/1994 Wildnauer et al. 356/334
5,774,207 A * 6/1998 Yoshida et al. 356/3.07
6,831,750 B2 12/2004 Mehrl et al.
7,110,103 B2 9/2006 Montgomery et al.
7,483,134 B2 * 1/2009 Toth et al. 356/328
2001/0019410 A1 * 9/2001 Kojima 356/334
2009/0153880 A1 * 6/2009 Klaver et al. 356/614

FOREIGN PATENT DOCUMENTS

JP 07270121 A * 10/1995

* cited by examiner

Primary Examiner—Michael P Stafira
(74) *Attorney, Agent, or Firm*—Lumen Patent Firm

(57) **ABSTRACT**

An angular magnification effect of diffraction is exploited to provide improved sensing and scanning. This effect is most pronounced for a normal or near-normal incidence angle in combination with a grazing diffraction angle, so such configurations are preferred. Angular sensitivity can be further enhanced because the width of the diffracted beam can be substantially less than the width of the incident beam. Normal incidence configurations with two symmetric diffracted beams are preferred, since rotation and vertical displacement can be readily distinguished. Increased sensitivity to vertical displacement can be provided by incorporating an interferometer into the measurement system. Quad cell detectors can be employed to provide sensitivity to rotation about the grating surface normal. A 2-D grating can be employed to provide sensitivity to angular displacements in two different planes (e.g., pitch and yaw). Combined systems can provide sensitivity to vertical displacement and to all three angular degrees of freedom.

23 Claims, 9 Drawing Sheets

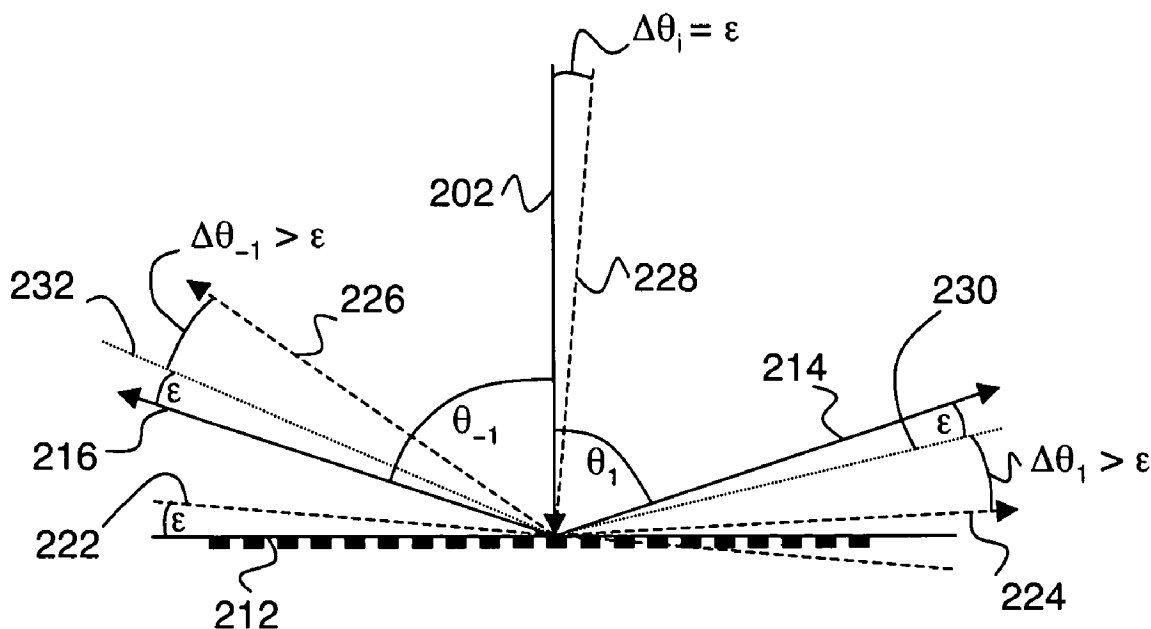

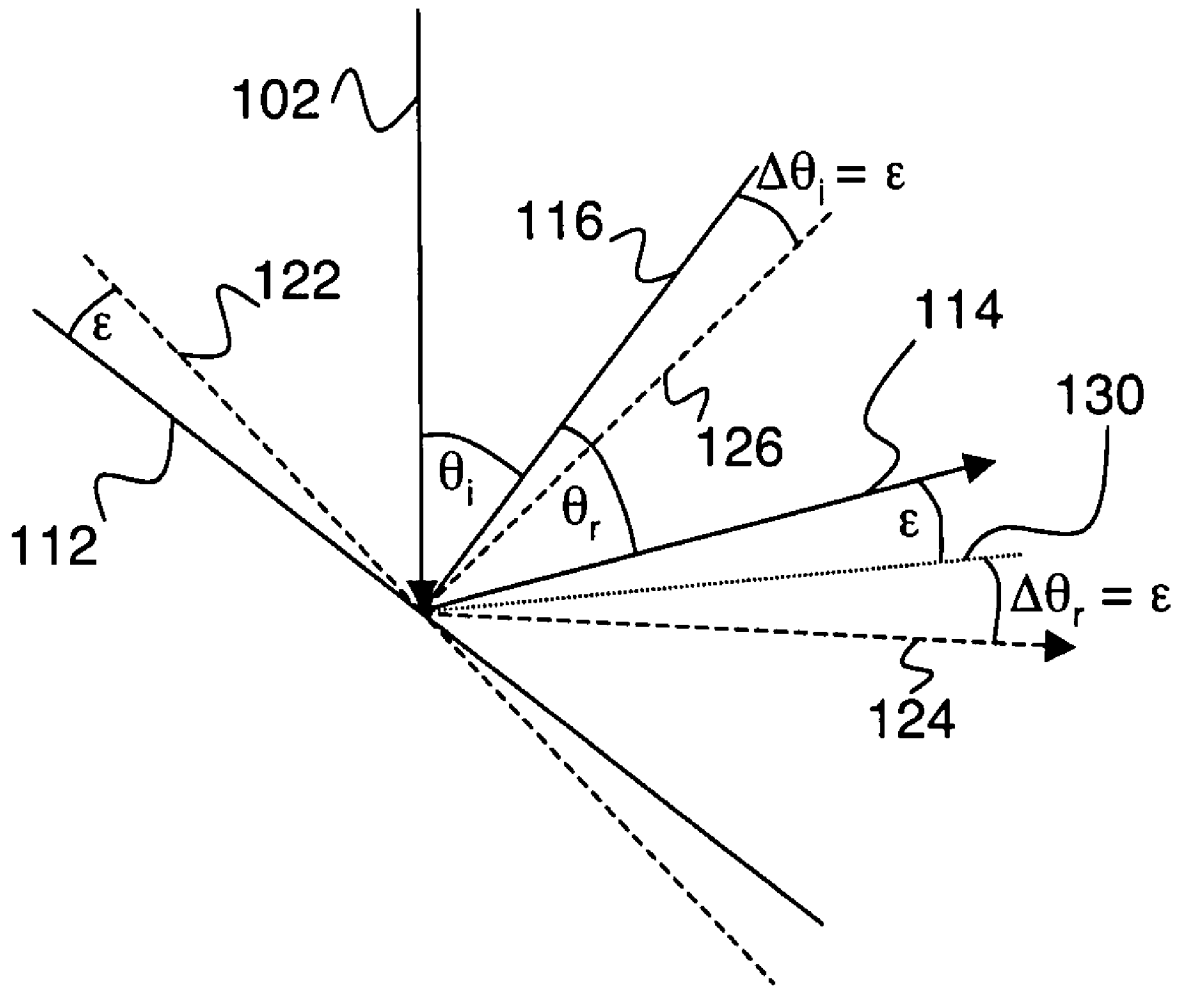

Fig. 1 (prior art)

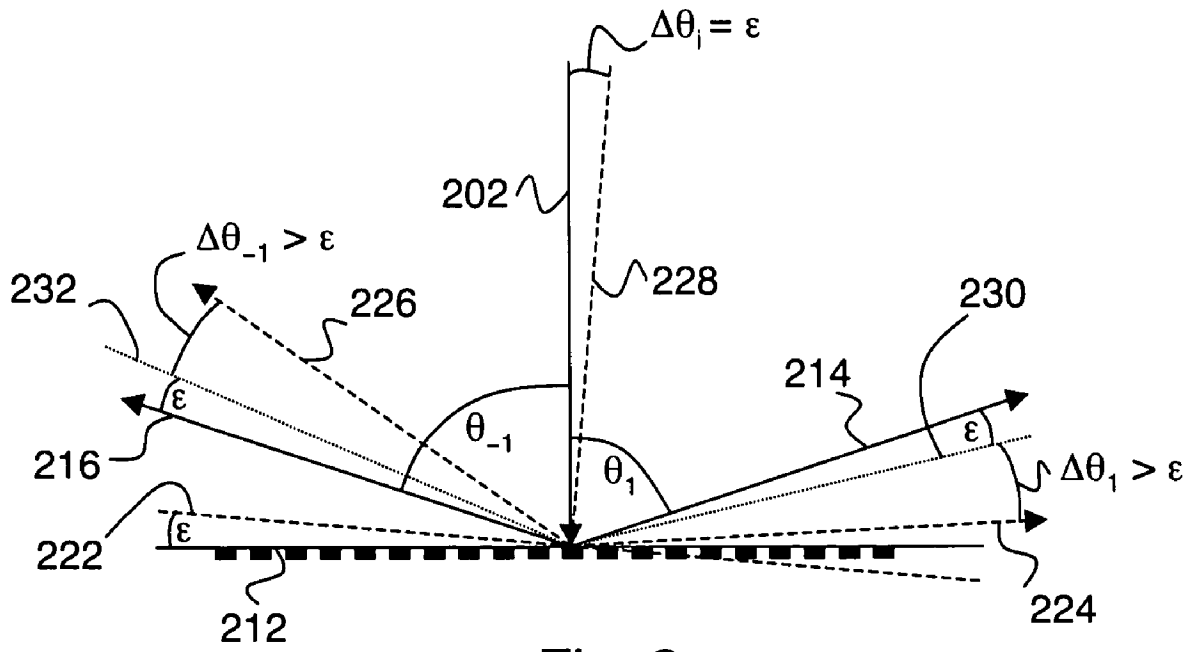

Fig. 2

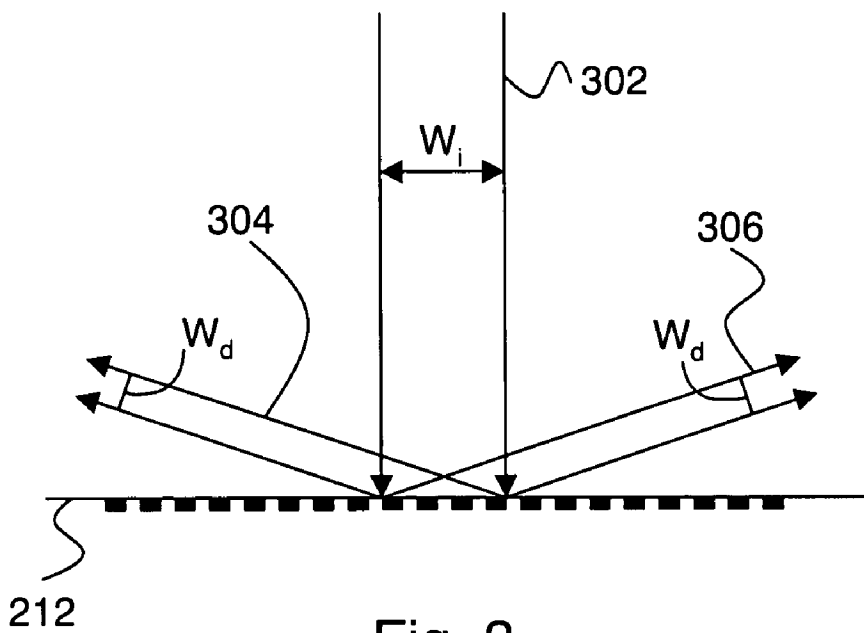

Fig. 3

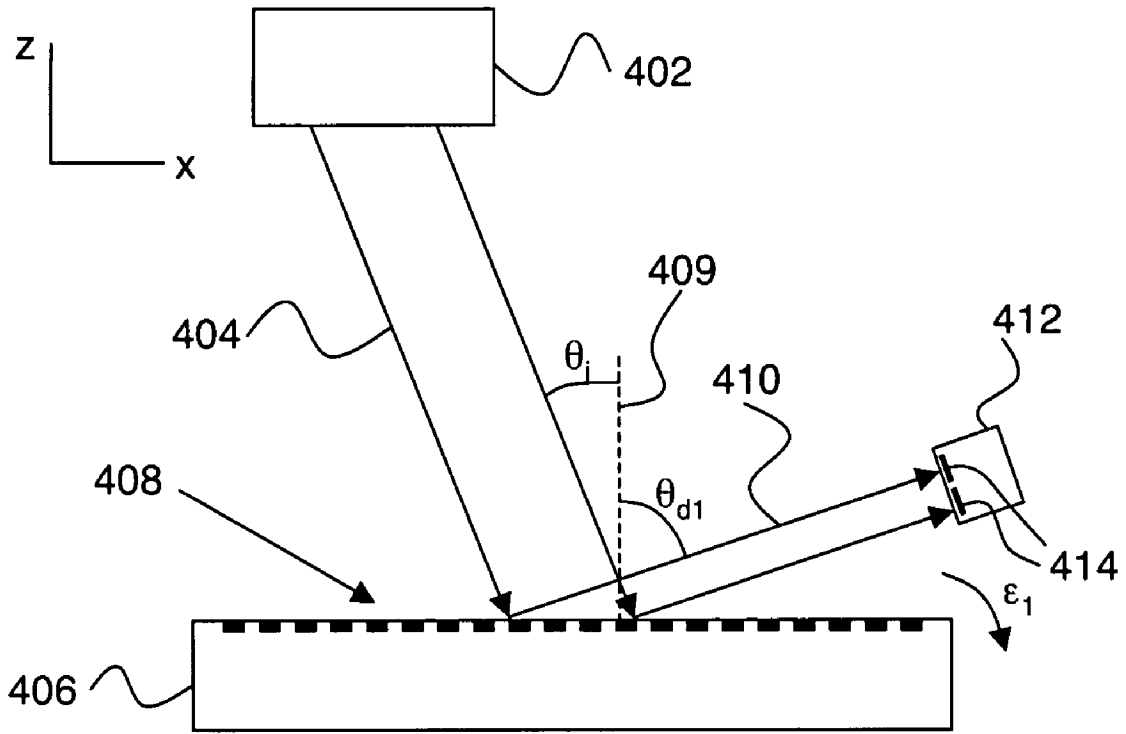

Fig. 4

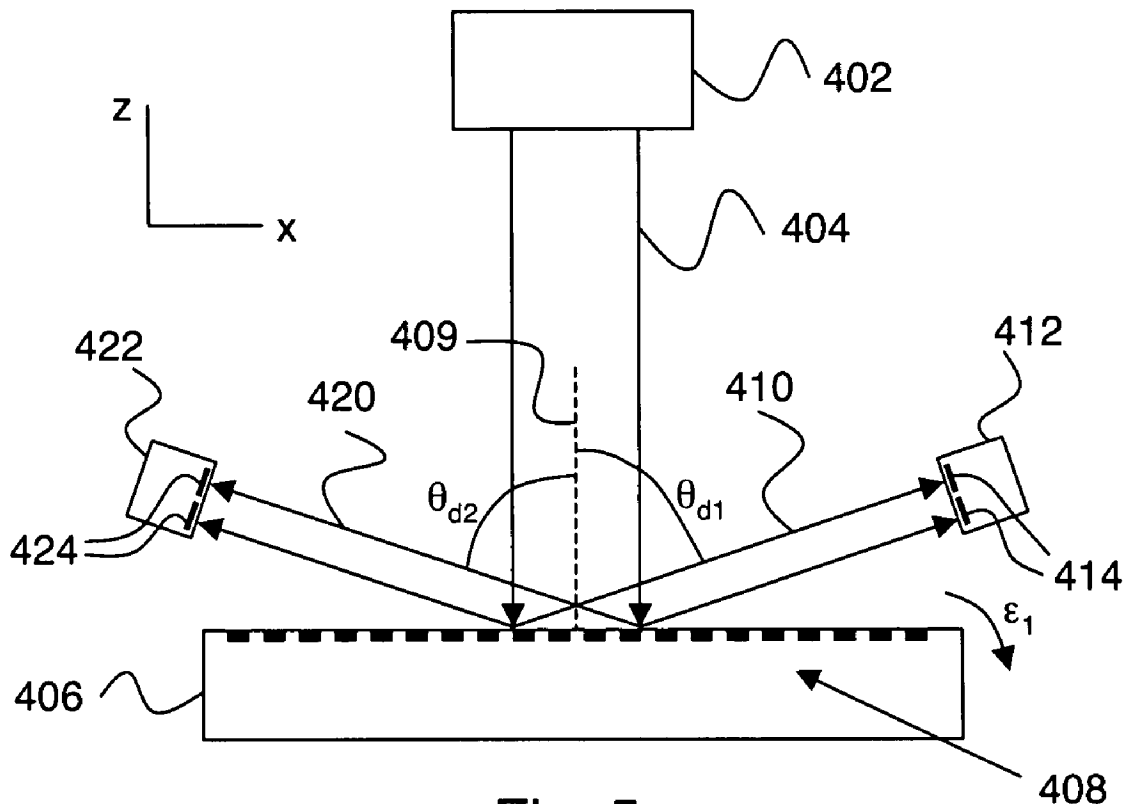
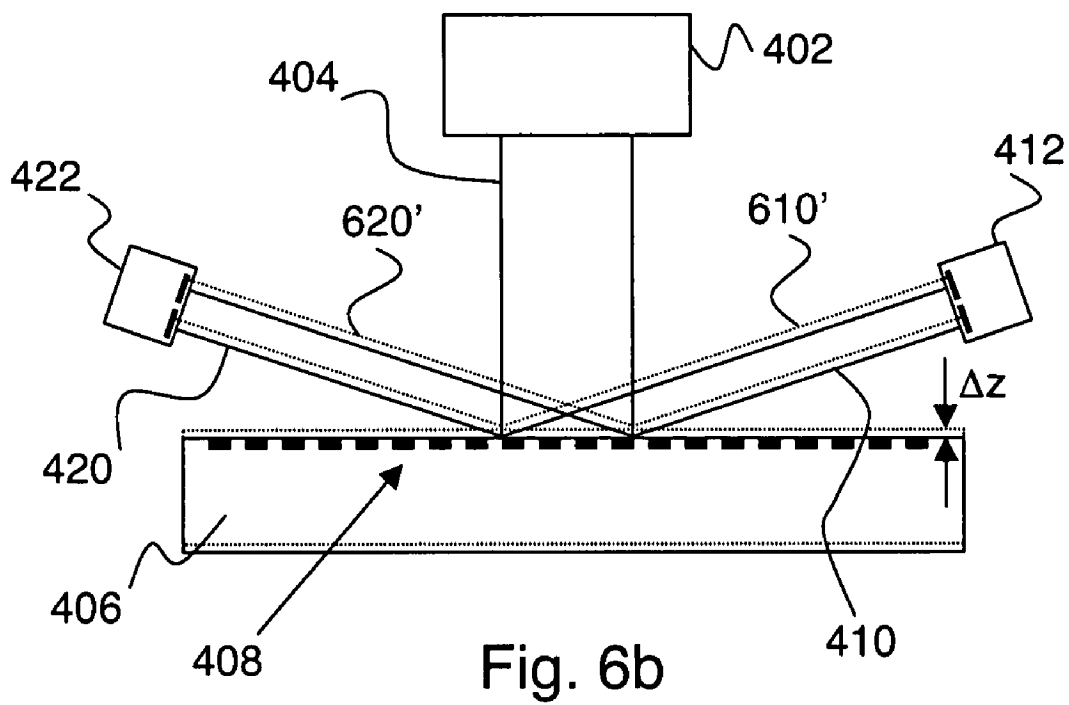
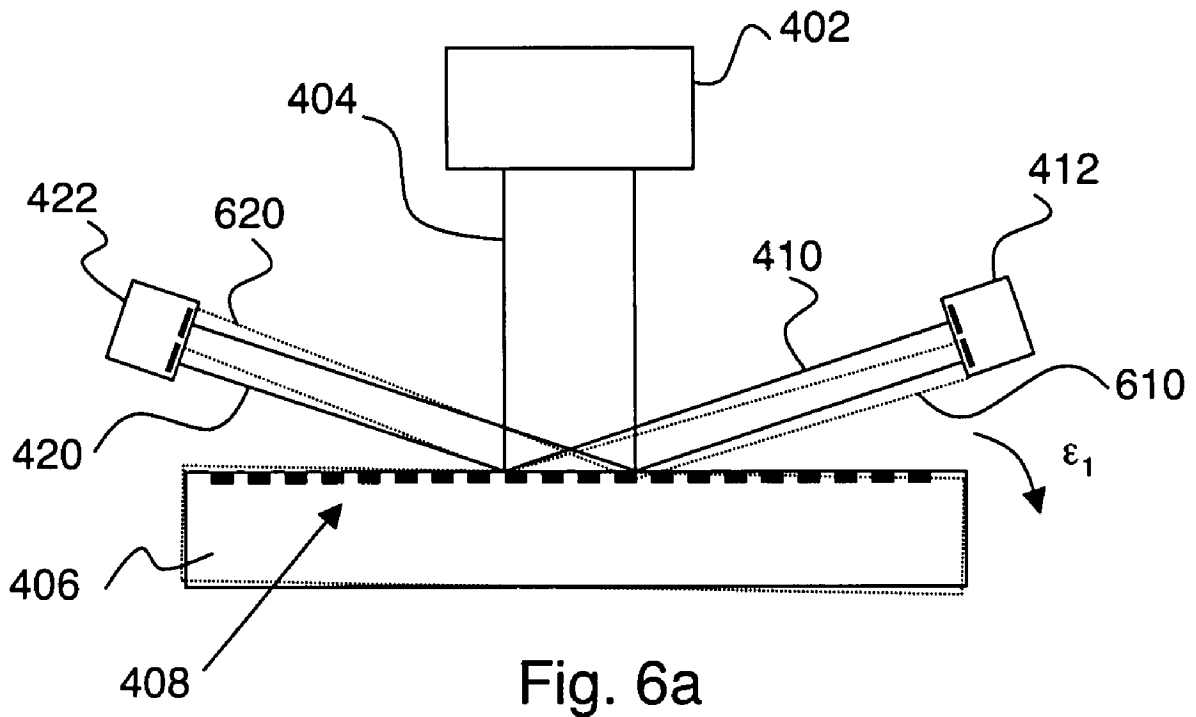

Fig. 5



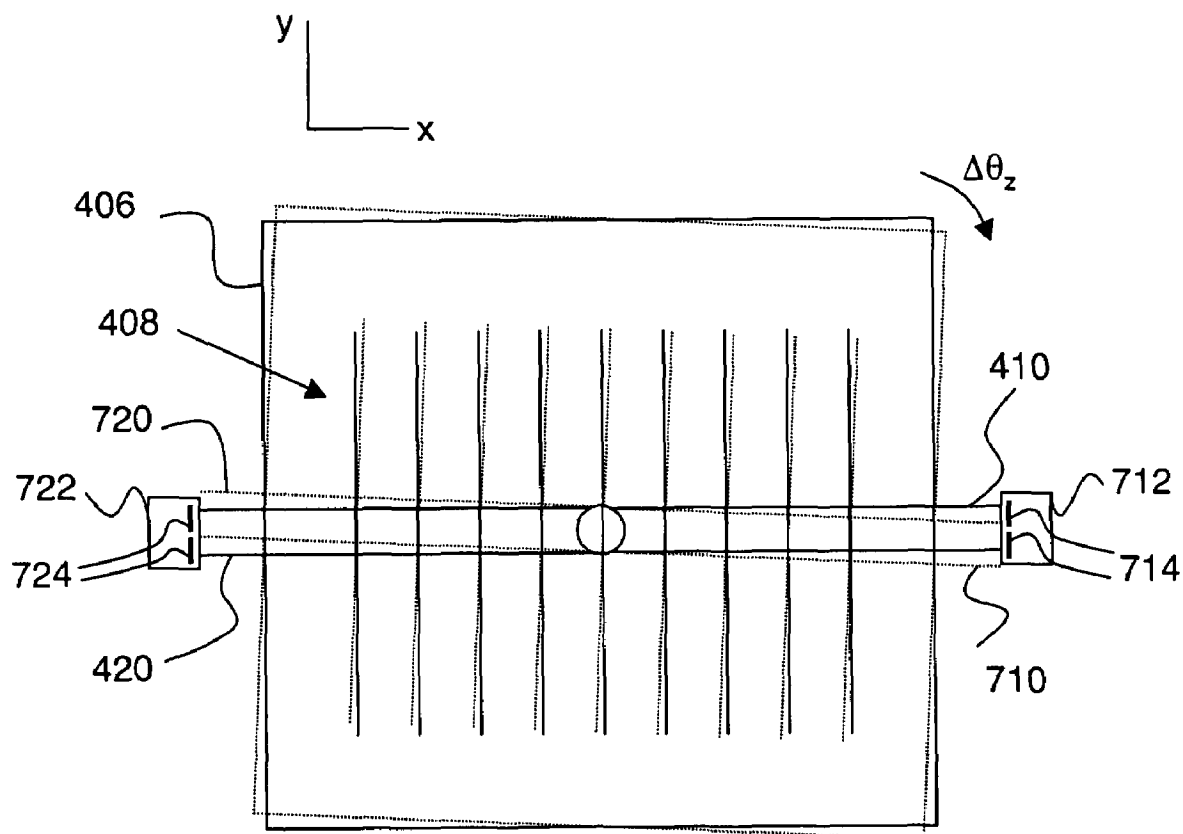

Fig. 7

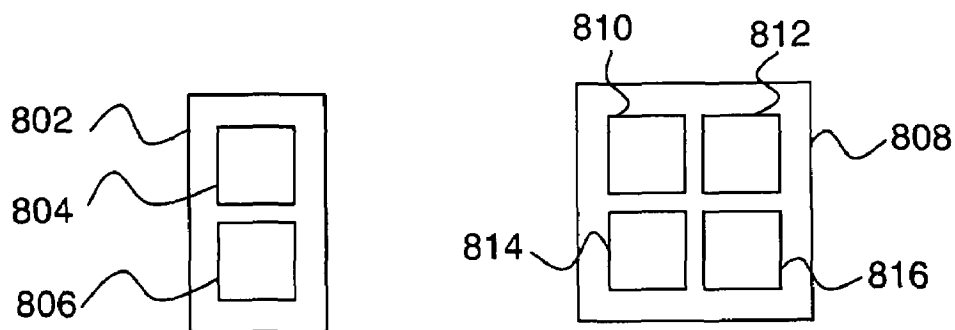

Fig. 8a

Fig. 8b

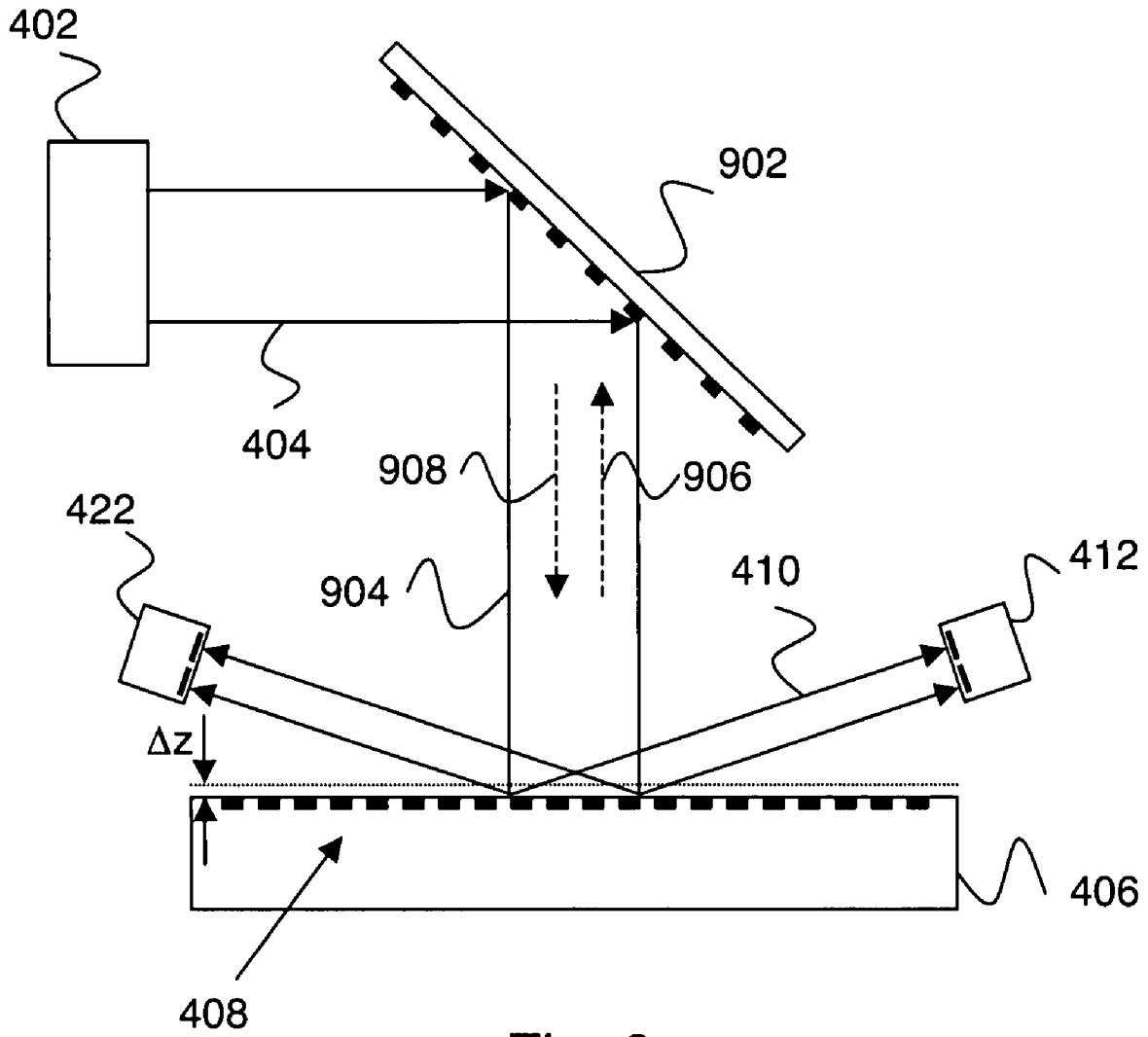

Fig. 9

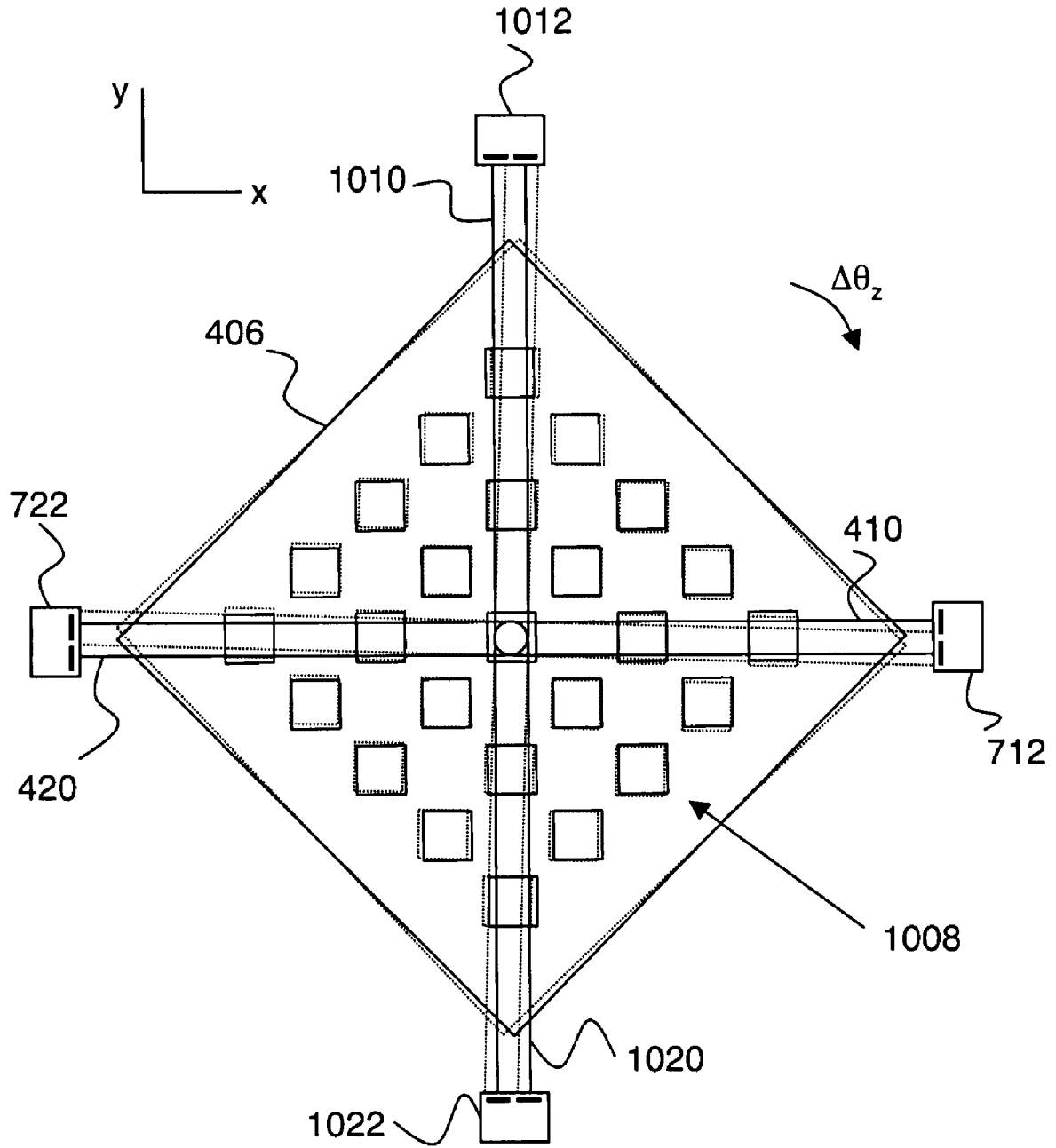

Fig. 10a

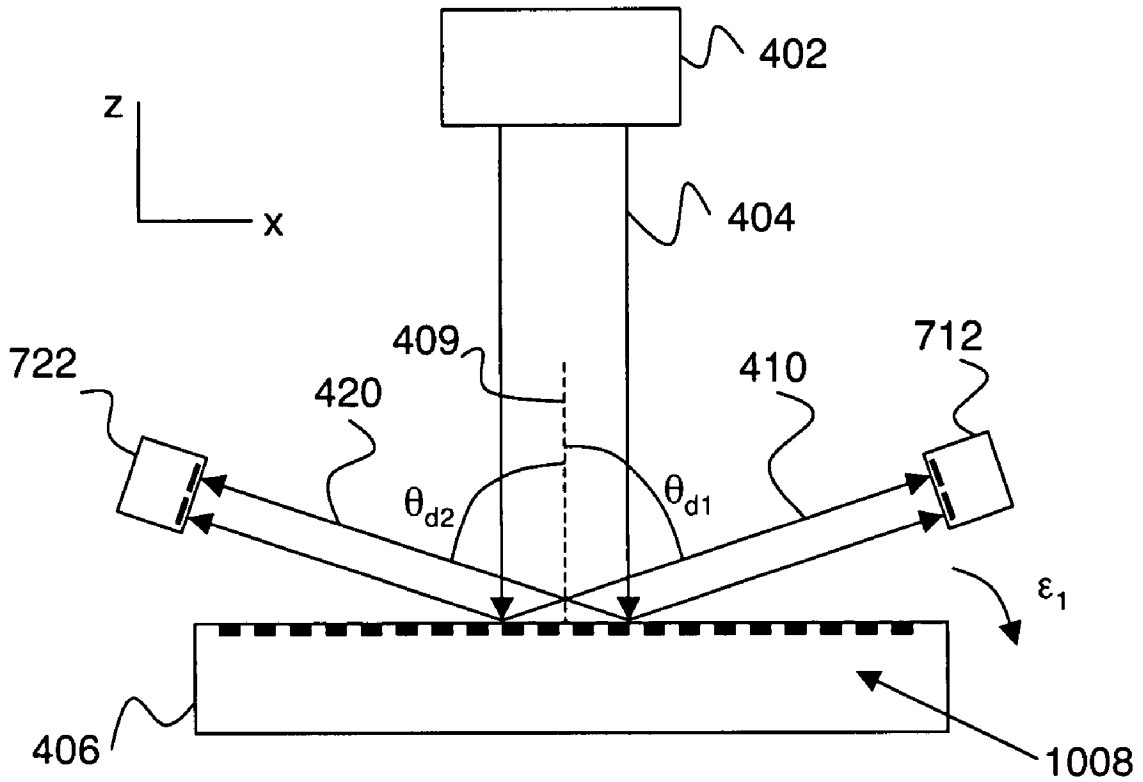

Fig. 10b

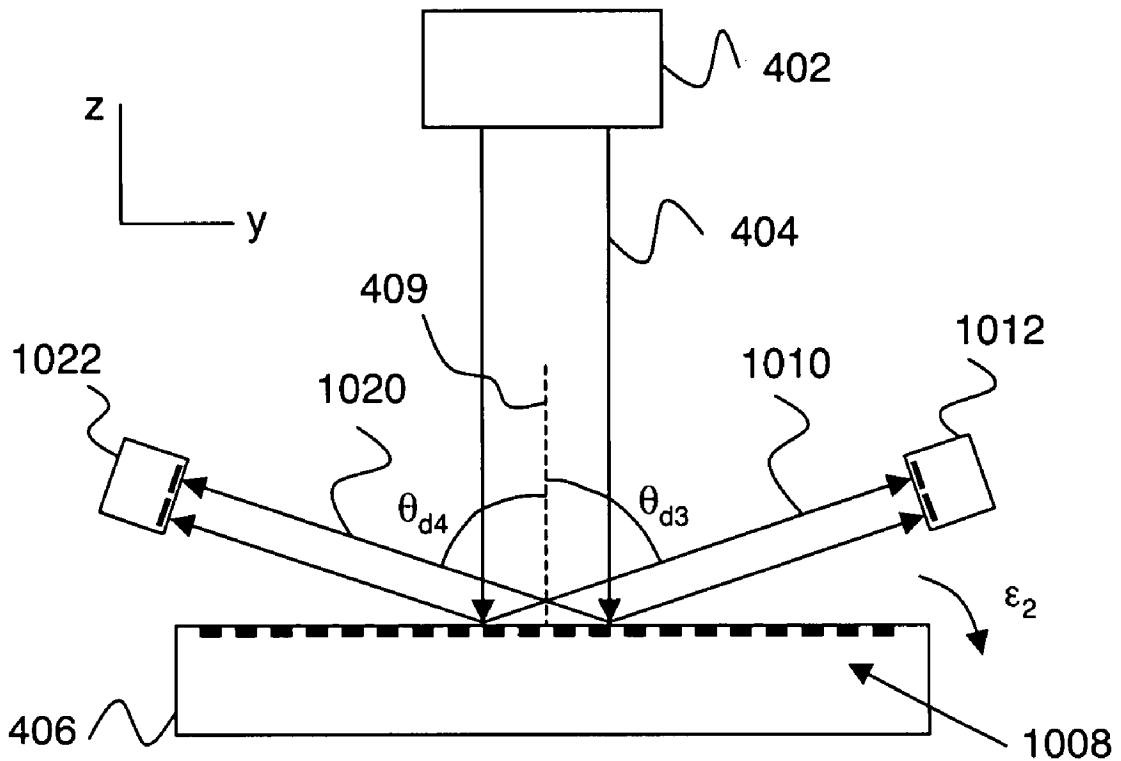

Fig. 10c

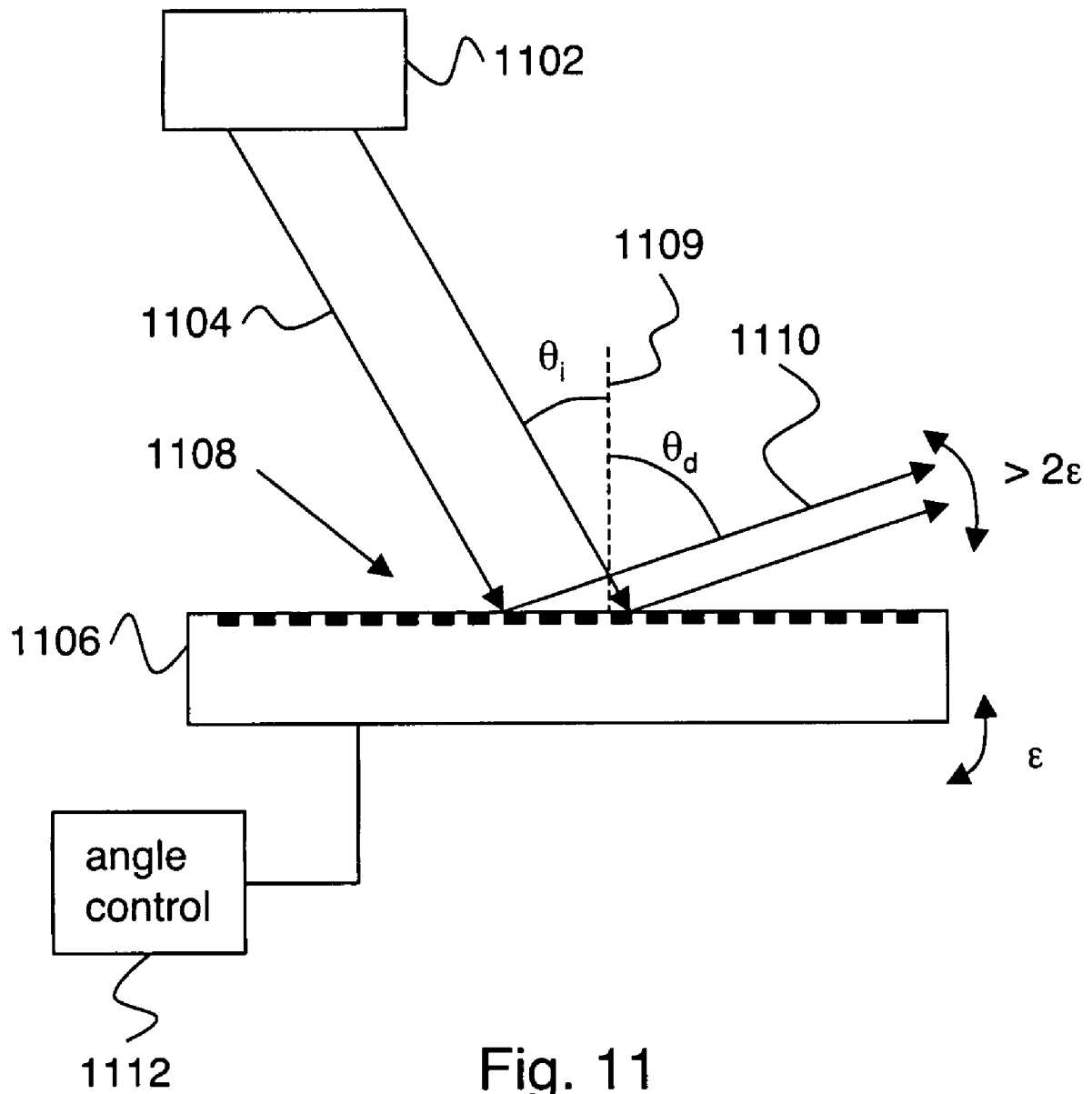

Fig. 11

GRATING ANGLE MAGNIFICATION ENHANCED ANGULAR SENSOR AND SCANNER

CROSS REFERENCE TO RELATED APPLICATIONS

This application claims the benefit of U.S. provisional patent application 60/815,098, filed on Jun. 19, 2006, entitled "Grating Angle Magnification Enhanced Angular Sensor and Scanner", and hereby incorporated by reference in its entirety.

GOVERNMENT SPONSORSHIP

This invention was made with government support under subcontract number 1273827 from NASA(JPL). The government has certain rights in this invention.

FIELD OF THE INVENTION

This invention relates to deflection of an optical beam for measuring angular displacement or for beam scanning.

BACKGROUND

Measuring an angular displacement of a test object by reflecting a beam of light from the test object and measuring the beam deflection corresponding to the angular displacement is well known in the art. The basic principles of this method are shown on FIG. 1. An incident light beam **102** is reflected from a surface **112** to provide a reflected beam **114**. If the angle of surface **112** changes, e.g., to align with dotted line **122**, incident light beam **102** would be reflected along path **124**. If the angular displacement of the reflective surface is ϵ , the corresponding difference in reflected beam direction is 2ϵ , which follows from the geometry of FIG. 1 and the reflection law ($\theta_i = \theta_r$).

It is also known in the art to measure angular displacement using optical systems that employ diffraction instead of or in addition to reflection. For example, U.S. Pat. No. 4,330,212 considers illumination of a diffraction grating on a test object. Changes in the position of the resulting diffraction pattern correspond to angular displacement of the test object. For example, a roll (rotation about the grating surface normal) of the test object will provide a corresponding roll of the diffraction pattern. A similar approach is also considered in U.S. Pat. No. 7,110,103.

In these references, diffraction is exploited to provide a pattern having multiple spots as opposed to a single reflected beam. Such a multiple spot pattern can provide information on angular displacements that cannot be measured with a single beam approach, such as rotation about the surface normal of the test object.

For the configuration of FIG. 1, the displacement of the reflected beam on a detector is $2\epsilon L$, assuming a reflected beam working distance of L from the test object to the detector. In some applications, such as space based gravitational wave sensors, it is simultaneously required to provide very high angular sensitivity in combination with a relatively limited working distance L . In such cases, it can be difficult or even impossible to meet the combined sensitivity and working distance requirements, thereby requiring an undesirable design compromise.

Accordingly, it would be an advance in the art to provide optical measurement of angular displacement having improved angular sensitivity.

SUMMARY

An angular magnification effect of diffraction is exploited to provide improved sensing and scanning. This effect is most pronounced for a normal or near-normal incidence angle in combination with a grazing diffraction angle, so such configurations are preferred. Angular sensitivity can be further enhanced because the width of the diffracted beam can be substantially less than the width of the incident beam. Normal incidence configurations with two symmetric diffracted beams are preferred, since rotation and vertical displacement can be readily distinguished. Increased sensitivity to vertical displacement can be provided by incorporating an interferometer into the measurement system. Quad cell detectors can be employed to provide sensitivity to rotation about the grating surface normal. A 2-D grating can be employed to provide sensitivity to angular displacements in two different planes (e.g., pitch and yaw). Combined systems can provide sensitivity to vertical displacement and to all three angular degrees of freedom.

BRIEF DESCRIPTION OF THE DRAWINGS

FIG. 1 shows a known arrangement for measuring angular change.

FIG. 2 is a diagram showing principles of the invention. FIG. 3 is another diagram showing principles of the invention.

FIG. 4 shows a first embodiment of the invention.

FIG. 5 shows a second embodiment of the invention.

FIGS. 6a-b show operation of the embodiment of FIG. 5. FIG. 7 shows a third embodiment of the invention.

FIG. 8a-b show detector configurations suitable for use in embodiments of the invention.

FIG. 9 shows a fourth embodiment of the invention.

FIGS. 10a-c show several views of a fifth embodiment of the invention.

FIG. 11 shows a sixth embodiment of the invention.

DETAILED DESCRIPTION

To better appreciate the principles of the present invention, it is helpful to first consider the conventional geometry of FIG. 1. Incident beam **102** is reflected by surface **112** to provide a reflected beam **114**. If an angular displacement of surface **112** shifts it to a new position **122**, the corresponding reflected beam would be beam **124**. The surface normal of surface **112** is shown as **116**, while the surface normal of the surface **122** is shown as **126**. Thus displacing surface **112** by ϵ causes a corresponding change in the angle of incidence, $\Delta\theta_i$, which is equal to ϵ . From the law of reflection ($\theta_i = \theta_r$), it follows that the corresponding change in the angle of reflection $\Delta\theta_r$ is also equal to ϵ . Because the angle between dotted line **130** and beam path **114** is ϵ , the angle between surface normal **126** and dotted line **130** is θ_r . The new reflected beam path **124** must make an angle with respect to surface normal **126** which is larger by $\Delta\theta_r = \epsilon$, as shown. Therefore, the difference between reflected beam path **114** and reflected beam path **124** is 2ϵ . To summarize, in the arrangement of FIG. 1 an angular displacement of ϵ causes a corresponding change in reflected angle $\Delta\theta$, which is equal to ϵ . The resulting deflection of the reflected beam from its original path is 2ϵ .

A key aspect of the present invention is the discovery that substantially higher angular sensitivity can be obtained in suitably selected diffraction geometries. FIG. 2 is a diagram showing principles of the invention. A normally incident beam **202** is diffracted from a diffraction grating **212**. In this

example, diffracted beams **214** and **216** correspond to 1 and -1 order diffraction respectively. As before, an angular displacement of grating **212** by ϵ shifts it to a new position shown schematically by dashed line **222**. Dotted lines **230** and **232** differ from beam paths **214** and **216** respectively by ϵ , which is also the change in angle of incidence shown by surface normal **228**.

The angular displacement of grating **212** induces corresponding changes in the 1 and -1 order diffraction angles, $\Delta\theta_1$ and $\Delta\theta_{-1}$ respectively, shown by beam paths **224** and **226**. These changes are determined by the grating equation:

$$d(\sin \theta_m - \sin \theta_i) = m\lambda, \quad (1)$$

where λ is the optical wavelength, m is the diffraction order, θ_i is the angle of incidence, θ_m is the m th order diffraction angle, and d is the grating period. For small angular displacements, Eq. 1 gives

$$\Delta\theta_m = M\Delta\theta_i, \quad (2)$$

where

$$M = \left(\frac{\cos\theta_i}{\cos\theta_m} \right). \quad (3)$$

The change in diffracted angle is related to the change in incidence angle via a magnification factor M , which in general can be less than 1, equal to one, or greater than one. For increased angular sensitivity relative to the conventional arrangement of FIG. 1, M is greater than one, which implies $\theta_i < \theta_m$, and preferably $M > 2$. More preferably, normal or near-normal incidence is employed (e.g., $\theta_i < 10^\circ$) and diffraction is at a grazing angle (e.g., $\theta_m > 75^\circ$). Significant angular magnification can be obtained. For example, if $\theta_i = 0^\circ$ and $\theta_m = 80^\circ$, $\Delta\theta_m = 5.8\Delta\theta_i$. As is well known in the art, selection of θ_i and θ_m in accordance with the above principles entails selection of θ_i , λ , d , and the diffraction order m .

An important advantage of the invention is that increased angular sensitivity is provided "for free", by the diffraction geometry itself. No further complications such as increased laser power are required to realize this advantage. This angular magnification effect does not appear to be appreciated in previous work relating to diffraction for measuring angular displacement.

Angular sensitivity is further enhanced by another consequence of the diffraction geometry, shown on FIG. 3. Here an incident beam **302** is diffracted from grating **212** to provide diffracted beams **304** and **306**. As shown, the width W_d of the diffracted beams is substantially less than the width W_i of the incident beam. Analysis shows that the beam widths are related as follows: $W_i = MW_d$, where M is the magnification factor as defined above. Thus for the preferred range $M > 2$, $W_d < 0.5 W_i$ follows. In practice, diffracted beam position is typically measured with a position sensitive photodetector (e.g., a split cell detector). Other things being equal, reducing the beam width at such a detector causes a proportionate increase in position sensitivity, because it is easier to precisely detect a small position change of a narrow beam than of a wide beam. In practice, both angular magnification and beam width reduction can be relevant, thereby providing a sensitivity improvement on the order of M^2 . For $\theta_i = 0^\circ$ and $\theta_m = 80^\circ$, $M^2 = 33$, and for $\theta_i = 0^\circ$ and $\theta_m = 85^\circ$, $M^2 = 132$.

The above-described principles can be applied in various ways to provide improved angular sensors and scanners. FIGS. 4-11 show several examples of embodiments of the invention.

FIG. 4 shows a first embodiment of the invention. In this example, an optical source **402** provides an incident beam **404** of substantially monochromatic optical radiation to a test body **406**. A grating **408** is disposed on test object **406** and is illuminated by incident beam **404**. Incident beam **404** is incident on grating **408** at an angle of incidence θ_i with respect to grating normal **409**. Grating **408** provides a first diffracted beam **410** responsive to the illumination by incident beam **404**. First diffracted beam **410** has a diffraction angle θ_{d1} with respect to grating normal **409**. A first diffraction plane is defined by the incident beam and first diffracted beam.

A first detector **412** receives first diffracted beam **410** and provides a first output Z_1 responsive to a position of diffracted beam **410** on detector **412** in the first diffraction plane. Such a position sensitive detector can be provided in various known ways, such as with a split cell detecting element **414**.

If the angular orientation of test object **406** is changed by a first change ϵ_1 from a reference orientation of test object **406**, corresponding changes $\Delta\theta_i$ and $\Delta\theta_{d1}$ of the incidence and diffraction angles are induced. As described above, $\Delta\theta_i = \epsilon_1$ and θ_i and θ_{d1} are selected such that $\Delta\theta_{d1}$ is substantially greater than ϵ_1 , thereby enhancing sensitivity due to the above-described angular magnification effect.

FIG. 5 shows a second embodiment of the invention. This example shows a preferred embodiment where normal incidence and symmetric diffraction into 1 and -1 orders are employed. Accordingly, in this embodiment it is preferred that grating **408** have a period such that at the wavelength of incident beam **404**, grating **408** diffracts only into orders 0, 1, and -1 . This embodiment is similar to the embodiment of FIG. 4, except that grating **408** also provides a second diffracted beam **420** responsive to the illumination by incident beam **404**. Second diffracted beam **420** has a diffraction angle θ_{d2} with respect to grating normal **409**. Second diffracted beam **420** is also in the first diffraction plane.

A second detector **422** having a split cell detecting element **424** receives second diffracted beam **420** and provides a second output Z_2 responsive to a position of diffracted beam **420** on detector **422** in the first diffraction plane. Angular displacement of test object **406** by an angle ϵ_1 also induces a corresponding change $\Delta\theta_{d2}$ of the diffraction angle θ_{d2} of second diffraction beam **420**. The change $\Delta\theta_{d2}$ is also substantially greater than ϵ_1 due to the above-described angular magnification effect.

FIGS. 6a-b show operation of the embodiment of FIG. 5. FIG. 6a shows the result of an angular displacement ϵ_1 , where first diffracted beam **410** moves to a new position **610**, and second diffracted beam **420** moves to a new position **620**. The corresponding outputs of the position sensitive detectors, Z_1 and Z_2 , change in opposite senses, since first beam **410** moves down on first detector **412** while second beam **420** moves up on second detector **422**.

FIG. 6b shows the result of a vertical displacement Δz , where first beam **410** moves to a new position **610'** and second beam **420** moves to a new position **620'**. The corresponding outputs of the position sensitive detectors, Z_1 and Z_2 , change in the same sense, since first beam **410** moves up on first detector **412** and second beam **420** also moves up on second detector **422**.

Since angular displacement and vertical displacement have different effects on the detector position outputs, these two perturbations of test body position can be readily distinguished, which is a significant advantageous feature of this embodiment. More specifically, a difference of Z_1 and Z_2 is responsive to angular displacement ϵ_1 but not to vertical displacement Δz , while a sum of Z_1 and Z_2 is responsive to vertical displacement Δz but not to angular displacement ϵ_1 .

Angular sensitivity is enhanced by the dual detector configuration, since both detectors can contribute to the rotation signal. Another advantage of this configuration is that differential mode rotation sensing avoids effects due to laser frequency noise, since such effects give rise to common-mode errors. Extraordinary sensitivity has been achieved in this configuration. In one experiment, 0.1 nrad/Hz^{1/2} sensitivity was demonstrated using a grating having 935 lines/mm at a wavelength of 1064 nm. The diffraction angles were about 84°, and the working distance was 6 cm. This combination of sensitivity and working distance is suitable for demanding applications, such as space based gravitational reference sensors.

FIG. 7 shows a third embodiment of the invention, where the detectors are modified to provide sensitivity to z-axis rotation $\Delta\theta_z$ in addition to the y-axis rotation sensitivity shown in connection with FIGS. 5 and 6a. FIG. 7 is a top view (i.e., x-y plane) as opposed to the side view (i.e., x-z plane) of FIG. 5. The embodiment of FIG. 7 is similar to the embodiment of FIG. 5, except that detectors 412 and 422 on FIG. 5 are replaced with detectors 712 and 722 having split cell detector elements 714 and 724 respectively. Detectors 712 and 722 provide position sensitive outputs Y_1 and Y_2 respectively, responsive to a lateral (i.e. y-directed) change in beam position, in addition to outputs Z_1 and Z_2 as described above. In more general terms, it is convenient to regard the first diffraction plane as defined with respect to a reference angular orientation of the test object. With this convention, detectors 712 and 722 are responsive to deviation of diffracted beams 410 and 420 from the first diffraction plane (e.g., as shown by beam positions 710 and 720 respectively). The difference of Y_1 and Y_2 is responsive to the angular displacement $\Delta\theta_z$. This embodiment provides measurement capability for $\Delta\theta_z$ in combination with the enhanced measurement sensitivity for angular displacement ϵ_1 of the embodiment of FIG. 5.

FIGS. 8a-b show detector configurations suitable for use in embodiments of the invention. FIG. 8a shows a split cell detector 802 having two separate detector elements 804 and 806. Such a detector is suitable for use in the embodiments of FIGS. 4 and 5, to provide vertical position outputs such as Z_1 and Z_2 . FIG. 8b shows a quad cell detector 808 having four separate detector elements 810, 812, 814, and 816. Such a detector is suitable for use in the embodiment of FIG. 7, to simultaneously provide vertical and lateral outputs, such as (Z_1, Y_1) from detector 712 and (Z_2, Y_2) from detector 714. Split cell and quad cell detectors suitable for use in embodiments of the invention are well known in the art. Any other method of observing or measuring diffracted beam position can also be employed in practicing the invention.

FIG. 9 shows a fourth embodiment of the invention, where an interferometer is added to the angular sensor to provide more sensitive capability for measuring vertical displacement Δz . This embodiment is similar to the embodiment of FIG. 5, except that a Littrow grating 902 is disposed in the incident beam path. Littrow grating 902 performs two functions. The first function is directing beam 404 to illuminate grating 408 as a normally incident beam 904. The second function is retro-diffracting light traveling along path 906 to propagate along path 908. Any grating arranged to provide such retro-diffraction can be referred to as a Littrow grating. Methods for selecting the grating period and the angles of incidence and diffraction for a given optical wavelength to provide a Littrow grating as described are well known in the art. Since the 0 order light from grating 408 (i.e., the specular reflection) propagates along path 906, the combination of grating 408

and Littrow grating 902 form an optical resonator, with light recirculating along paths 906 and 908.

With this arrangement, the total power in diffracted beams 410 and 420 will depend periodically on the vertical displacement Δz , in accordance with well known principles of interferometry. Detectors 412 and 422 can provide power outputs P_1 and P_2 which are responsive to Δz . Determination of Δz can be based on four measured quantities: $P_1, P_2, Z_1,$ and Z_2 .

To maximize sensitivity, it is preferable for the interferometer in the example of FIG. 9 to be impedance matched. More specifically, let η_0 be the 0 order diffraction efficiency of grating 408 (i.e., the fraction of normally incident light that is diffracted into 0 order). Let η_L be the Littrow efficiency of grating 902 (i.e., the fraction of incident light along path 906 that is retro-diffracted along path 908). Impedance matching the resonator entails selecting the various design parameters such that $\eta_0 = \eta_L$.

Sensitivity to all three angular degrees of freedom can be provided by employing principles of the invention in connection with a two-dimensional grating on the test object. FIGS. 10a-c show several views of such an embodiment of the invention.

FIG. 10a is a top view showing a 2-D grating 1008 on test object 406. Normally incident light on grating 1008 is diffracted into a first diffracted beam 410, a second diffracted beam 420, a third diffracted beam 1010, and a fourth diffracted beam 1020. Beams 410, 420, 1010, and 1020 are received by first, second, third and fourth detectors 712, 722, 1012, and 1022 respectively. These detectors can be quad cell detectors. Detectors 712 and 722 provide outputs Y_1 and Y_2 responsive to lateral deviation of the first and second diffracted beam from the first diffraction plane, as described in connection with FIG. 7. Similarly, detectors 1012 and 1022 provide outputs X_3 and X_4 responsive to lateral deviation of the third and fourth diffracted beams from a second diffraction plane. The second diffraction plane (y-z plane) in this example is perpendicular to the first diffraction plane (x-z plane). The differences $Y_1 - Y_2$ and $X_3 - X_4$ are responsive to rotation about the grating surface normal $\Delta\theta_z$.

FIG. 10b shows a view in the first diffraction plane (x-z plane). First diffracted beam 410 has a diffraction angle θ_{d1} with respect to grating normal 409. Second diffracted beam 420 has a diffraction angle θ_{d2} with respect to grating normal 409. An angular displacement ϵ_1 of test object 406 in the first diffraction plane (i.e., a rotation about the y axis) provides corresponding changes $\Delta\theta_{d1}$ and $\Delta\theta_{d2}$ in the diffraction angles. The changes $\Delta\theta_{d1}$ and $\Delta\theta_{d2}$ are substantially greater than ϵ_1 due to the above-described angular magnification effect. Detectors 712 and 722 provide position sensitive outputs Z_1 and Z_2 respectively. As described above in connection with FIGS. 6a-b, the sum $Z_1 + Z_2$ is responsive to vertical displacement Δz and the difference $Z_1 - Z_2$ is responsive to angular displacement ϵ_1 .

FIG. 10c shows a view in the second diffraction plane (y-z plane). Third diffracted beam 1010 has a diffraction angle θ_{d3} with respect to grating normal 409. Fourth diffracted beam 1020 has a diffraction angle θ_{d4} with respect to grating normal 409. An angular displacement ϵ_2 of test object 406 in the second diffraction plane (i.e., a rotation about the x axis) provides corresponding changes $\Delta\theta_{d3}$ and $\Delta\theta_{d4}$ in the diffraction angles. The changes $\Delta\theta_{d3}$ and $\Delta\theta_{d4}$ are substantially greater than ϵ_2 due to the above-described angular magnification effect. Detectors 1012 and 1022 provide position sensitive outputs Z_3 and Z_4 respectively. As described above in connection with FIGS. 6a-b, the sum $Z_3 + Z_4$ is responsive to vertical displacement Δz and the difference $Z_3 - Z_4$ is responsive to angular displacement ϵ_2 .

7

The combined sum $Z_1+Z_2+Z_3+Z_4$ can be used as a measure of Δz . Vertical displacement sensing in the embodiment of FIGS. 10a-c can also be enhanced by combining it with vertical interferometry as described in connection with FIG. 9.

Principles of the invention are applicable to angular scanning as well as to angular displacement sensing as described above. FIG. 11 shows a beam deflector or scanner in accordance with an embodiment of the invention. An optical source 1102 provides a substantially monochromatic beam 1104 of optical radiation to a diffraction grating 1108 disposed on a deflector 1106. Beam 1104 is incident on grating 1108 at an angle of incidence θ_i , and a diffracted beam 1110 is diffracted from grating 1108 at a diffraction angle θ_d . As described above, an angular displacement ϵ of deflector 1106 provides corresponding changes $\Delta\theta_i$ and $\Delta\theta_d$ in the incidence and diffraction angle. The change $\Delta\theta_d$ is substantially larger than ϵ , and $\Delta\theta_i=\epsilon$. An angle control 1112 can be employed to vary the angular displacement of deflector 1106. The resulting deflection in diffracted beam angle is $>2\epsilon$. More specifically, the diffracted beam deflection is $\epsilon(1+M)$, where $M>1$ is the above-defined magnification factor. A conventional mirror-based beam deflector would provide a reflected beam deflection of 2ϵ . Such angular magnification can provide increased bandwidth in applications such as laser printing laser scanning, and optical switching.

If scanning is performed over a significant range of angles, it may be important to account for the nonlinearity of the dependence of $\Delta\theta_d$ on ϵ . Such nonlinearity can be accounted for by appropriate pre-compensation of angle control 1112. For example, an inverse-cosine pre-compensation can be employed to drive ϵ in a nonlinear manner such that $\Delta\theta_d$ changes linearly during a scan.

The invention claimed is:

1. Apparatus for measuring a change of angular orientation of a test object, the apparatus comprising;

an optical source providing an incident beam of substantially monochromatic optical radiation to said test object at an angle of incidence θ_i , wherein a diffraction grating disposed on said test object is illuminated by said incident beam and provides a first diffracted beam having a first diffraction angle θ_{d1} responsive to said incident beam;

wherein for a reference angular orientation of said test object, said incident beam and said first diffracted beam define a first diffraction plane;

a first optical detector receiving said first diffracted beam and providing a first output responsive to a position of said first diffracted beam on said first detector in said first diffraction plane;

wherein a first change ϵ_1 of angular orientation of said test object in said first diffraction plane relative to said reference angular orientation induces corresponding changes $\Delta\theta_i$ of said angle of incidence and $\Delta\theta_{d1}$ of said first diffraction angle;

wherein $\Delta\theta_i=\epsilon_1$ and wherein θ_i and θ_{d1} are selected such that $\Delta\theta_{d1}$ is substantially greater than ϵ_1 .

2. The apparatus of claim 1, wherein $\Delta\theta_d>2\epsilon_1$.

3. The apparatus of claim 1, wherein a width W_d of said first diffracted beam in said first diffraction plane is substantially less than a width W_i of said incident beam in said first diffraction plane.

4. The apparatus of claim 1, wherein $W_d<0.5W_i$.

5. The apparatus of claim 1, wherein $\theta_i<10^\circ$ and wherein $\theta_{d1}>75^\circ$.

6. The apparatus of claim 1, wherein a wavelength of said optical radiation and a period of said diffraction grating are

8

selected such that diffraction from said diffraction grating only occurs in orders 0, 1, and -1.

7. The apparatus of claim 1, wherein said first optical detector comprises a split cell photodetector.

8. The apparatus of claim 1, wherein said first optical detector comprises a quad cell photodetector further providing a lateral output responsive to a deviation of said first diffracted beam from said first diffraction plane;

wherein said lateral output provides a measure of rotation $\Delta\theta_z$ of said test object about a surface normal of said diffraction grating.

9. The apparatus of claim 1, further comprising an optical interferometer responsive to a displacement Δz of said test object along a surface normal direction of said diffraction grating.

10. The apparatus of claim 9, wherein θ_i is substantially equal to zero, and wherein said interferometer comprises a Littrow grating disposed in a path of said incident beam to form an optical resonator defined by said Littrow grating and by said diffraction grating on said test object.

11. The apparatus of claim 10, wherein a 0 order diffraction efficiency of said diffraction grating on said test object is substantially equal to a Littrow diffraction efficiency of said Littrow grating.

12. The apparatus of claim 1, further comprising a second optical detector receiving a second diffracted beam having a second diffraction angle θ_{d2} from said diffraction grating and providing a second output responsive to a position of said second diffracted beam in said first diffraction plane on said second detector;

wherein said first change ϵ_1 of angular orientation of said test object induces a corresponding change $\Delta\theta_{d2}$ of said second diffraction angle;

wherein θ_i and θ_{d2} are selected such that $\Delta\theta_{d2}$ is substantially greater than ϵ_1 .

13. The apparatus of claim 12, wherein θ_i is substantially equal to zero, and wherein said first and second diffracted beams are provided by 1 and -1 order diffraction.

14. The apparatus of claim 13, wherein a difference between said first and second outputs is provided as a measure of said angular change ϵ_1 .

15. The apparatus of claim 14, wherein a sum of said first and second outputs is provided as a measure of displacement Δz of said test object along a surface normal direction of said diffraction grating.

16. The apparatus of claim 1, wherein said diffraction grating is a 2-dimensional grating having periodicity in two distinct directions.

17. The apparatus of claim 16, wherein said diffraction grating provides a third diffracted beam having a third diffraction angle θ_{d3} responsive to said incident beam;

wherein for a reference angular orientation of said test object, said incident beam and said third diffracted beam define a second diffraction plane, wherein said first and second diffraction planes intersect;

further comprising a third optical detector receiving said third diffracted beam and providing a third output responsive to a position of said third diffracted beam on said third detector in said second diffraction plane;

wherein a second change ϵ_2 of angular orientation of said test object in said second diffraction plane relative to said reference angular orientation induces corresponding changes $\Delta\theta_i$ of said angle of incidence and $\Delta\theta_{d3}$ of said third diffraction angle;

wherein $\Delta\theta_i=\epsilon_2$ and wherein θ_i and θ_{d3} are selected such that $\Delta\theta_{d3}$ is substantially greater than ϵ_2 .

9

18. The apparatus of claim 17, further comprising a second optical detector receiving a second diffracted beam having a second diffraction angle θ_{d2} from said diffraction grating and providing a second output responsive to a position of said second diffracted beam in said first diffraction plane on said second detector;

wherein said first change ϵ_1 of angular orientation of said test object induces a corresponding change $\Delta\theta_{d2}$ of said second diffraction angle;

wherein θ_i and θ_{d2} are selected such that $\Delta\theta_{d2}$ is substantially greater than ϵ_1 .

19. The apparatus of claim 18, further comprising a fourth optical detector receiving a fourth diffracted beam having a fourth diffraction angle θ_{d4} from said diffraction grating and providing a fourth output responsive to a position of said fourth diffracted beam in said second diffraction plane on said fourth detector;

wherein said second change ϵ_2 of angular orientation of said test object induces a corresponding change $\Delta\theta_{d4}$ of said fourth diffraction angle;

wherein θ_i and θ_{d4} are selected such that $\Delta\theta_{d4}$ is substantially greater than ϵ_2 .

20. The apparatus of claim 19, wherein a difference between said first and second outputs is provided as a measure of said angular change ϵ_1 ,

wherein a difference between said third and fourth outputs is provided as a measure of said angular change ϵ_2 , and wherein a sum of said first, second, third, and fourth outputs is provided as a measure of displacement Δz of said test object along a surface normal direction of said diffraction grating.

21. The apparatus of claim 19, wherein said first, second, third, and fourth optical detectors each comprise a quad cell photodetector further providing, respectively:

10

a first lateral output responsive to deviation of said first diffracted beam from said first diffraction plane;

a second lateral output responsive to deviation of said second diffracted beam from said first diffraction plane;

a third lateral output responsive to deviation of said third diffracted beam from said second diffraction plane;

a fourth lateral output responsive to deviation of said fourth diffracted beam from said second diffraction plane;

and wherein said first, second, third, and fourth lateral outputs provide a measure of rotation $\Delta\theta_z$ of said test object about a surface normal of said diffraction grating.

22. Apparatus for deflecting an optical beam, the apparatus comprising:

an optical source providing an incident beam of substantially monochromatic optical radiation;

a deflector comprising a diffraction grating, wherein said incident beam is incident on said diffraction grating at an angle of incidence θ_i , and wherein said diffraction grating provides a diffracted beam having a diffraction angle θ_d responsive to said incident beam;

wherein for a reference angular orientation of said deflector, said incident beam and said diffracted beam define a diffraction plane;

wherein a change ϵ of angular orientation of said deflector in said diffraction plane relative to said reference angular orientation induces corresponding changes $\Delta\theta_i$ of said angle of incidence and $\Delta\theta_d$ of said diffraction angle;

wherein $\Delta\theta_i = \epsilon$ and wherein θ_i and θ_d are selected such that $\Delta\theta_d$ is substantially greater than ϵ .

23. A scanner comprising the apparatus of claim 22.

* * * * *