

# Terrestrial Applications of the Thermal Infrared Sensor, TIRS

**Ramsey L. Smith**  
Planetary Systems  
Laboratory  
NASA Goddard  
Space Flight  
Center  
Greenbelt, MD,  
USA  
Ramsey.L.Smith@N  
ASA.gov

**Kurtis Thome**  
Hydrospheric and  
Biospheric  
Laboratory  
NASA Goddard  
Space Flight  
Center  
Greenbelt, MD,  
USA  
Kurtis.Thome@N  
ASA.gov

**Cathleen  
Richardson**  
TIRS Instrument  
Manager  
NASA Goddard  
Space Flight Center  
Greenbelt, MD, USA  
Cathleen.M.Richard  
son@NASA.gov

**James Irons**  
Laboratory for  
Atmospheres  
NASA Goddard  
Space Flight Center  
Greenbelt, MD, USA  
James.R.Irons@NAS  
A.gov

**Dennis Reuter**  
Planetary Systems  
Laboratory  
NASA Goddard  
Space Flight  
Center  
Greenbelt, MD,  
USA  
Dennis.C.Reuter@  
NASA.gov

**Abstract-** *Landsat satellites have acquired single-band thermal images since 1978. The next satellite in the heritage, Landsat Data Continuity Mission (LDCM), is scheduled to launch in December 2012. LDCM will contain the Operational Land Imager (OLI) and the Thermal Infrared Sensor (TIRS), where TIRS operates in concert with, but independently of OLI. This paper will provide an overview of the remote sensing instrument TIRS. The TIRS instrument was designed at National Aeronautics and Space Administration's (NASA) Goddard Space Flight Center (GSFC) where it will be fabricated and calibrated as well. Protecting the integrity of the Scientific Data that will be collected from TIRS played a strong role in definition of the calibration test equipment and procedures used for the optical, radiometric and spatial calibration. The data that will be produced from LDCM will continue to be used world wide for environment monitoring and resource management.*

**Keywords:** Thermal Infrared Sensor, Landsat data continuity mission, quantum well infrared photodetector, land resource management, terrestrial spacecraft

## 1 Introduction

For over 30 years the Landsat satellite program has provided an extensive archive of global high-resolution, highly calibrated, multispectral data of Earth's landmasses. Since 1978, Landsat satellites have also acquired single-band thermal images. The Landsat Data Continuity Mission (LDCM) is scheduled to launch in December 2012 and it will be a polar orbiting satellite. LDCM will contain the Operational Land Imager (OLI) and the Thermal Infrared Sensor (TIRS), where TIRS operates in concert with, but independently of OLI.

The intent of this paper is to give an overview of the TIRS instrument and its benefit to the remote sensing community. TIRS passed its Preliminary Design Review (PDR) and it will be delivered in December 2011. The PDR served as a medium for the TIRS subsystems to demonstrate that their preliminary designs met the mission requirements with acceptable risk and within the cost and schedule constraints.

TIRS is a two channel, 10.8 and 12  $\mu\text{m}$ , thermal imager that was developed at GSFC. Its purpose will be to provide data continuity for the Landsat thermal band. It will produce radiometrically calibrated, geo-located thermal image data. Data products from TIRS will benefit the global community, from agriculture to public health. The data from TIRS and OLI will be processed and merged into a single data product by the United States Geological survey (USGS)/Earth Resources Observation and Science (EROS) facility.

## 2 TIRS Data Products

Landsat data products are used world wide for environment monitoring and resource management. Some of these applications include volcano surveillance, public health vector monitoring, fire-induced vegetation depletion and urban heat island evaluations. These data products are usually not measured directly, however, they are derived from computational models and image analysis. Some of the equations used in the computational models and image analysis are listed below:

$$R_{NET} = G + ET + H \quad (1)$$

$$R_{NET} = (SW_{dn} - SW_{up}) + (LW_{dn} - LW_{up}) \quad (2)$$

where  $R_{NET}$  is the net radiation of Earth. Both thermal and shortwave observations are required to calculate  $R_{NET}$ .  $G$  is soil heat conduction flux.  $H$  is sensible heat. Shortwave observations are required to calculate the leaf area index, attenuation of  $R_{NET}$  through the canopy of vegetation and the fraction of cover.  $ET$  is latent heat or evapotranspiration and the leaf area index is the ratio of total upper leaf surface of vegetation divided by the surface area of the land where the vegetation resides.

OLI is required to calculate the shortwave albedo. TIRS data is required to calculate the upwelled thermal infrared or upwelled thermal longwave radiation,  $LW_{up}$ , from the surface temperature. Thermal observations are required to calculate the surface temperature,  $SW_{up}$ .

Landsat thermal data are currently used operationally to monitor water consumption on a field-by-field basis in the western states of the United States of America and internationally. This is allowed by the development of operational energy balanced-based evapotranspiration models, such as METRIC (Mapping Evapotranspiration with High Resolution and Internalized Calibration). Evapotranspiration cools vegetation and therefore shows a temperature difference between the various surfaces in the landscape frame.

Urban heat islands can be examined by comparing the net solar radiation absorbed by different surface categories and by following their transformations through different forms of thermal energies in an attempt to establish energy balance [4]. Examples of these surface categories are bare soil, forest areas, urban areas and bodies of water. Maps of sensible heat flux can be produced from data derived from TIRS.

Remote sensing thermal infrared data has been used to monitor and document active volcanoes for over 20 years. TIRS will be an additional spaceborne resource for remote sensing capability of volcanic surveillance. This is important for monitoring volcanic activity in developing countries and in remote locations. The data products will aid in mapping volcanic products and thermal volcanic features. Some of the volcanic features include volcanic craters, crater lakes and domes.

Monitoring fire-induced vegetation depletion can produce burnt area mapping which will lead to wildfire risk assessment and will provide an accurate account of fire severity [5]. Vegetation index, VI, is one of the variables used to determine vegetation depletion and it can be derived from thermal data provided by TIRS. Plant water content is confirmed as a key parameter in monitoring forest depletions [5].

Over the past few decades, researchers have used remote sensing data to assess environmental factors that promote disease transmission, disease vector production

and the risk for human-vector contact. Some of these environmental factors include crop type, soil moisture and deforestation [2]. Public health concerns can be tracked by the aforementioned environmental factors to identify vectors associated with vector borne diseases, such as malaria and lyme disease. These variables will be effectively mapped with the data derived from TIRS.

### 3 Instrument

TIRS will deliver radiometrically corrected data from 2 thermal channels, 10.8 and 12  $\mu\text{m}$  that are geometrically registered and geodetically located. Other missions have integrated thermal infrared instruments into their payload and they are: the High Resolution Infrared Sounder (HIRS), the Advanced Very High Resolution Radiometer (AVHRR), and the Moderate Resolution imaging Spectroradiometer (MODIS). The higher resolution of TIRS, at least 120-meters, will provide data that will improve thermal imaging information content and environmental monitoring when compared to the aforementioned instruments, Figure 1.

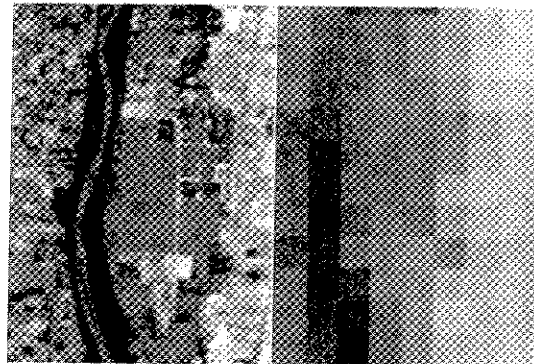

Figure 1. An infrared image of the Middle Rio Grande near Albuquerque, NM. Landsat image is on the left and the MODIS image is on the right.

#### 3.1 Instrument Design

The Landsat Data Continuity Mission has been designed to have a two-instrument payload, the Operational Land Imager and the Thermal Infrared Sensor. Figure 2 shows the configuration of both instruments intergrated on the Landsat spacecraft. An ATLAS V- Evolved Expendable Launch Vehicle (EELV) will launch the LDCM spacecraft into orbit.

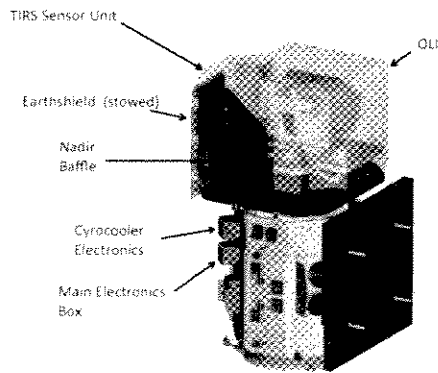

Figure 2. Instrument payload diagram of the Landsat Data Continuity Mission satellite

The TIRS design is a product of the NASA Goddard Space Flight Center. Currently in process, the functional performance model (FPM) and flight model of the instrument are being built in house.

The infrared radiation from the Earth or the onboard calibration source will be traverse through the optical path to then be focused on the detector using the telescope assembly. The scene select mechanism and mirror are along the optical path and they will allow for the instrument to change the view from the nadir baffle to view the target planet Earth, to instead view one of the two calibration sources (Figure 3). The power, mechanical control and the thermal control will be conducted through the onboard LDCM electronics package.

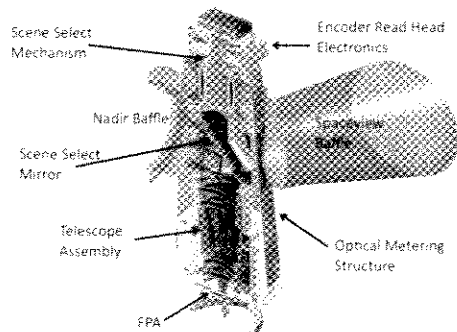

Figure 3. TIRS unit internal view

### 3.2 Instrument Specifications

TIRS instrument components have been specified to meet the science goals of the LDCM mission. Instrument components include the focal plane array, the telescope assembly, the scene select mechanism/mirror, the space view baffle and the nadir view baffle. Figure 3 displays a cross section of TIRS and the labeled components. The specifications of these components were selected to allow the instrument to be structurally sound, efficient and perform to a high fidelity.

The telescope assembly has four lenses, one lens composed of zinc selenide, ZnSe, and the other three are composed of germanium. The passively cooled telescope assembly is designed to operate at 180 K. The detector sensor on the instrument will be a quantum well infrared photodetector (QWIP) focal plane array (FPA), which will be connected to the bottom of the telescope assembly.

Quantum well infrared photodetector focal plane array is a 3-sensor chip assembly built by NASA Goddard Space Flight Center, Figure 4. It is actively cooled by a cryocooler to an operating temperature of 43 K. The instrument's two spectral bands are achieved through interference filters that cover the FPA.

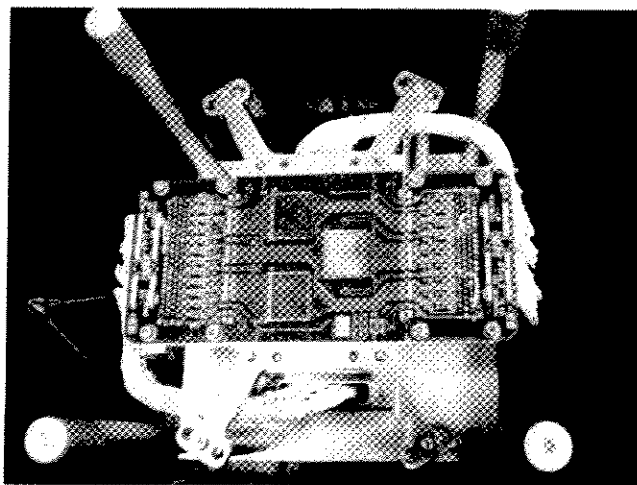

Figure 4. Fully assembled and operational QWIP focal plane assembly

The precision scene select mirror is an essential component of the TIRS instrument and it is driven by the scene select mechanism. It rotates around the optical axis on a 45-degree plane to provide the telescope with a view of Earth through the nadir baffle and two full aperture sources of calibration, onboard variable temperature blackbody (hot calibration target) and space view (cold calibration target). The onboard blackbody will be a National Institute of Standards and Technology (NIST) certified reference source. The output from the onboard

will be capable of providing two temperature measurements between 260 and 330 K within two orbits.

TIRS is able to achieve a 185 km ground swath with a 15° field of view functioning in the pushbroom sample collection method. This method will have the benefit of being able to collect and record data without movement artifacts due to its wide instantaneous field of view. Frames will be collected at an operating cadence of 70 per second. TIRS is a high resolution IR sensor with a resolution that is less than 120 m. The collected data will be stored temporarily stored onboard and periodically sent to the USGS EROS facility for further storage. The instrument is designed to have an expected lifetime of at least a three-years.

## 4 Calibration

During the ground calibration testing, TIRS performance will be measured at the component, subsystem and system level. Our responsibility is to provide an instrument that is well calibrated, well characterized with specification compliant data that will ensure the data continuity of Landsat from the previous missions to the present. System-level radiometric and image quality is assessed using a functional performance model (FPM) of the instrument. Instrument-level requirements played a strong role in definition of the calibration test equipment and procedures used for the radiometric and spatial calibration in the thermal/vacuum chamber.

Algorithm developments for instrument control and data analysis have been developed in concert with calibration and validation testing. The algorithms used during calibration and validation testing will be the basis of the algorithms used during flight.

Calibration testing will be taking place in a vacuum test chamber at NASA GSFC. A clean test covering the door opening provides a Class 10,000 clean area for integrating hardware prior to loading it into the chamber. TIRS Calibration System, TIRSCS in Figure 5, will allow for optical, radiometric and geometric features of TIRS to be calibrated. MEI and ATK CORPORATION manufactured and supplied the specified calibration package.

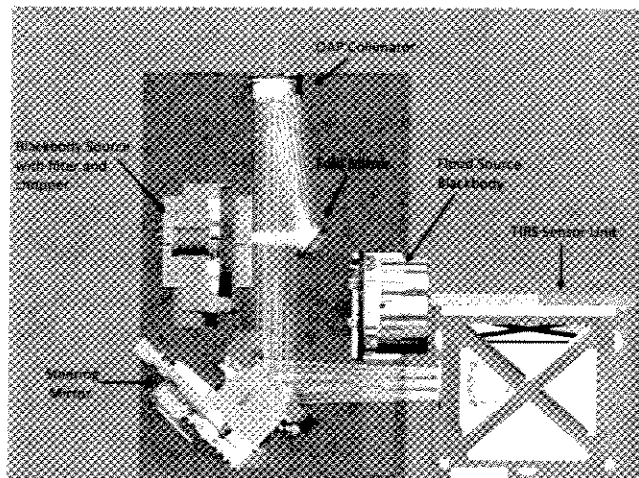

Figure 5: TIRS calibration system

TIRS will implement two types of sources in the thermal vacuum chamber and one source outside of the chamber. The first type of infrared projection will use a 16-aperture source system combined with a 9-filter system to simulate a target with high radiometric accuracy. The targets will be super imposed by passing the flux through the fold mirror and an off axis parabola (OAP) collimator and can be placed anywhere in the TIRS field of view (FOV) using the two-axis steering mirror. The second type of source will be the flood source and it is in front of the TIRS to cover the FOV. The linear stage will be used to translate the flood source in and out of the FOV of TIRS. The monochromator source will be located outside of the chamber and it will impose its flux through ZnSe window and with OAP collimator mounted to the side of the blackbody housing. All acceptance testing and calibration of the TIRS instrument is performed at NASA GSFC.

Functional Performance Model calibration will allow for the evaluation of instrument and component performance while the flight model of the instrument is still being fabricated. Furthermore, calibration testing will aid in the risk mitigation of the instrument. Data collected during calibration will validate the various instrument systems and component models. Spectral data will be collected under simulated on-orbit thermal conditions in vacuum with the focal plane and telescope at operating temperature. During thermal vacuum tests, the spectral response will be determined for each band to verify stability and spectral performance. The TIRS calibration team will provide real-time data collection and visualization of the calibration tests. All of the outputs from the test will be saved to the appropriate media to allow for detailed post-test analysis by the science team.

## 5 Conclusions and Future Plans

The global community depends on Landsat data products for environment monitoring and resource

management. Every detail of LDCM and the TIRS instrument reflects its meticulous design and commitment to provide quality scientific data. The TIRS Instrument Science team is on track to provide an instrument that is well calibrated, well characterized with specification compliant data that will ensure the data continuity of Landsat from the previous missions to the present.

The next stage in the evolution of TIRS is the instrument Critical Development Review, (CDR). The objectives during CDR are to demonstrate that TIRS is on schedule to meet mission requirements and that the maturity of the project is appropriate to support continue with fabrication, assembly, integration, and test. In preparation for CDR, the calibration team will continue the system level characterization of the FPM and prepare for the future characterization of the flight instrument.

## Acknowledgment

We would like to acknowledge thanks to NASA, NASA Goddard Space Flight Center, USGS, TIRS Instrument team, and the Landsat Data Continuity Mission team.

## References

- [1] White, J.D., Ryan, K.C., Key, C.C., and S.W. Runnings, "Remote sensing of forest fire severity and vegetation recovery," *International Journal of Remote Sensing*, Vol. 17, No. 6, pp. 125-136, 1996
- [2] Beck, L.R., B.M. Lobitz, B.L. Wood. "Remote sensing and human health: New sensors and new opportunities," *Emerging Infectious Diseases*, Vol. 6, No. 3, pp. 217-227, 2000.
- [3] Ernst, G.G.J., M. Kervyn, R.M. Teeuw. "Advances in the remote sensing of volcanic activities and hazards, with special consideration to applications in developing countries" *International Journal of Remote Sensing*, Vol. 29, No. 22, pp. 6687-6723, 2005
- [4] H.H. Hun, "Urban Heat-Island," *International Journal of Remote Sensing*, Vol. 13, No. 12, pp. 2319-2336, 1992.
- [5] J. Rogan and S.R. Yool "Mapping fire-induced vegetation depletion in the Peloncillo Mountains, Arizona and New Mexico", *International Journal of Remote Sensing*, Vol. 22, No. 16, pp. 3101-3121, 2001.