



The **Power Pack** attached to the bottom of the handle of the power drill utilizes ultracapacitors, rather than batteries, to store energy.

- Excellent low-temperature performance makes ultracapacitors suitable for storing energy in applications at temperatures too low for batteries.
- The consistent performance of ultracapacitors over time enables reliable operation not possible with batteries.
- Unlike batteries, ultracapacitors can be safely left completely discharged for indefinitely long times.
- Whereas the charge-discharge efficiency in conventional power management using rechargeable batteries is typically about 50 percent, the charge-discharge efficiency in HPM typically exceeds 90 percent.

For the cordless drill, a dedicated charger is used to fully realize the advantages of the ultracapacitors as energy-storage devices. Because of the non-critical nature of charging and dis-

charging of ultracapacitors, this charger is less complex and less costly than would be a battery charger for the same power drill. More spectacularly, taking advantage of the unique charging characteristics of ultracapacitors, this charger can make the ultracapacitor-powered cordless drill ready for operation in seconds, in contradistinction to the several hours needed to recharge batteries.

*This work was done by Dennis J. Eichenberg of Glenn Research Center. Further information is contained in a TSP (see page 1).*

*Inquiries concerning rights for the commercial use of this invention should be addressed to NASA Glenn Research Center, Innovative Partnerships Office, Attn: Steve Fedor, Mail Stop 4-8, 21000 Brookpark Road, Cleveland, Ohio 44135. Refer to LEW-18116-1.*

## Cumulative Timers for Microprocessors

Accumulated operating times and serial numbers would be displayed.

NASA's Jet Propulsion Laboratory, Pasadena, California

It has been proposed to equip future microprocessors with electronic cumulative timers, for essentially the same reasons for which land vehicles are equipped with odometers (total-distance-traveled meters) and aircraft are equipped with Hobbs meters (total-engine-operating-time meters). Heretofore, there has been no way to determine the amount of use to which a microprocessor (or a product containing a microprocessor) has been subjected. The proposed timers would count all microprocessor clock cycles and could only be read by means of microprocessor instructions but, like odometers and Hobbs meters, could never be reset to zero without physically damaging the chip.

A timer according to the proposal could be either an external device connected to a microprocessor or embedded within the microprocessor. The external implementation could be retrofit to a pre-existing microprocessor. In the external implementation (see figure), the timer would include a prescaler; an inter-integrated-circuit (I<sup>2</sup>C) or a serial peripheral interface (SPI) module; and a flash random-access memory (RAM) that would store a unique serial number and a prescaler-reduced count of clock cycles, both of which could be read over a one- or two-wire bus.

The serial number stored in the flash RAM would serve as the serial number

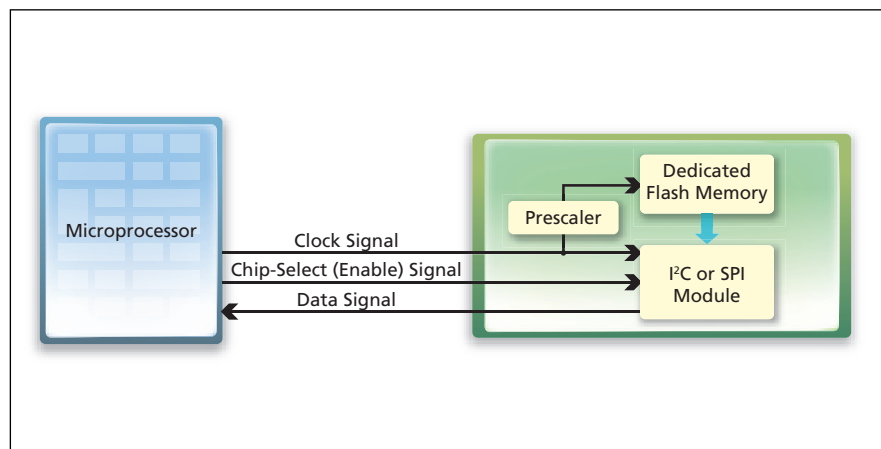

A **Cumulative Timer** could be added to a microprocessor as an electrically connected external unit. Alternatively, it could be incorporated as an integral part of the microprocessor.

of the microprocessor and of any equipment containing the microprocessor, for purposes of registering any warranty of the equipment and verifying the authenticity of the equipment. On a display generated by the microprocessor, the user could compare the electronically stored serial number with the serial number printed on a label affixed to the equipment and the serial number on the warranty registration and could read the accumulated operating time. Periodically, during normal operation, the microprocessor would attempt to interrogate the flash memory

and would turn itself off if it were unable to read its proper serial number. Upon each such interrogation, the count stored in the flash memory would be incremented.

The internal implementation would function similarly to the external implementation, except that the serial number and the prescaler-reduced count of clock cycles would be stored in either (1) part of the flash RAM used by the rest of the microprocessor or (2) a separate flash RAM dedicated to the timer. It would be necessary to design the microprocessor hardware

and software so that there would be no way to decrement the count or otherwise exert external control over the timer flash RAM.

*This work was done by John O. Battle of Caltech for NASA's Jet Propulsion Laboratory. Further information is contained in a*

*TSP (see page 1).*

*In accordance with Public Law 96-517, the contractor has elected to retain title to this invention. Inquiries concerning rights for its commercial use should be addressed to:*

*Innovative Technology Assets Management  
JPL*

*Mail Stop 202-233*

*4800 Oak Grove Drive*

*Pasadena, CA 91109-8099*

*(818) E-mail: [iaoffice@jpl.nasa.gov](mailto:iaoffice@jpl.nasa.gov)*

*Refer to NPO-43599, volume and number of this NASA Tech Briefs issue, and the page number.*