

# 600-GHz Electronically Tunable Vector Measurement System

The design satisfies a complex set of technical and economic requirements.

NASA's Jet Propulsion Laboratory, Pasadena, California

A compact, high-dynamic-range, electronically tunable vector measurement system that operates in the frequency range from  $\approx 560$  to  $\approx 635$  GHz has been developed as a prototype of vector measurement systems that would be suitable for use in nearly-real-time active submillimeter-wave imaging. A judicious choice of intermediate frequencies makes it possible to utilize a significant amount of commercial off-the-shelf communication hardware in this system to keep its cost relatively low. The electronic tunability of this system has been proposed to be utilized in a yet-to-be-developed imaging system in which a frequency-dispersive lens would be used to steer transmitted and received beams in one dimension as a function of frequency. Then acquisition of a complete image could be effected by a combination of frequency sweeping for scanning in the aforesaid dimension and mechanical scanning in the perpendicular dimension.

As used here, "vector measurement system" signifies an instrumentation system that applies a radio-frequency (RF) excitation to an object of interest and measures the resulting amplitude and phase response, relative to either the applied excitatory signal or another reference signal related in a known way to applied excitatory signal. In the case of active submillimeter-wave imaging, the RF excitation would be a submillimeter-wavelength signal radiated from an antenna aimed at an object of interest, and the response signal would be a replica of

the RF excitation as modified in amplitude and phase by reflection from or transmission through the object.

The system is depicted schematically in the figure. The ultimate sources of the RF excitation and reference signals and of local-oscillator (LO) signals for use in down-conversion of the response signal are two compact, inexpensive microwave synthesizers that are electronically tunable over the frequency range from 14 to 18 GHz in increments of 250 kHz. The outputs of both synthesizers are multiplied  $\times 6$  in frequency. The resulting signals, having frequencies in the neighborhood of 100 GHz, are amplified  $\approx 20$  dB by a pair of monolithic microwave integrated-circuit (MMIC) amplifiers. Then one of the amplified signals is further multiplied  $\times 6$  in frequency for use as the RF excitation signal, while the other is further multiplied  $\times 3$  in frequency for use as the LO signal in a subharmonically pumped mixer.

The RF excitation signal is radiated and made to pass through or reflect from an object of interest, and the response signal is mixed with the aforementioned subharmonic LO signal to generate a down-converted signal [denoted an intermediate-frequency (IF) signal in the radio art]. The RF and LO synthesizers are controlled from a laptop computer, which adjusts their frequencies to keep the IF constant at 450 MHz. Thus, the RF- and LO-synthesizer outputs differ in frequency by  $450/36 = 12.5$  MHz.

The phase and amplitude measurements are performed indirectly, on signals derived from the IF signal, rather than directly on the RF response signal. For the purpose of generating a phase reference signal, portions of the outputs of the RF and LO synthesizers are mixed, yielding a 12.5-MHz signal, which is then multiplied  $\times 36$  in frequency to obtain another 450-MHz signal. This 450-MHz signal cannot be used directly as the phase reference signal because the outputs of the inexpensive microwave synthesizers have such poor phase-noise characteristics that this signal and the 450-MHz IF signal are indistinguishable from the accompanying phase noise. Therefore, it is necessary to perform further processing as described next.

In particular, it is necessary to further reference both the 450-MHz IF and the 450-MHz reference signal to a stable source before detection. This involves down-converting the raw 450-MHz reference signal by 12.79 MHz by use of a 12.79-MHz fundamental crystal oscillator, a mixer, and a band-pass filter. The resultant 437.21-MHz signal is then mixed with the 450-MHz IF signal. Inasmuch as the phase noises of the 437.21-MHz signal and the 450-MHz IF signal are totally correlated, mixing these two signals cancels out that noise, leaving a 12.79-MHz signal that has the same amplitude and phase characteristics (minus the synthesizer noise) as does the 450-MHz IF signal.

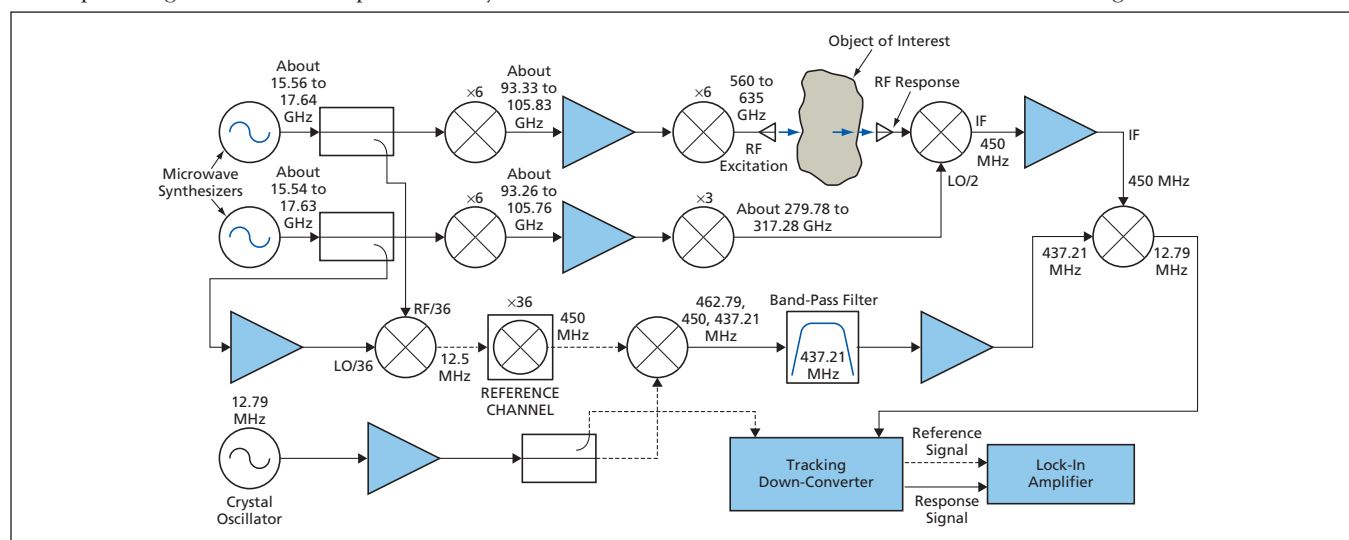

This **Vector Measurement System** is made from a combination of commercially available and custom components. The complexity of the reference channel is necessitated by a requirement to cancel phase noise that originates in the microwave synthesizers.

It should be noted that any 450-MHz signal passing through the 437.21-MHz band-pass filter would be down-converted along with the 437.21-MHz signal, resulting in cross-talk and loss of dynamic range. It is therefore essential that the 437.21-MHz band-pass filter have extremely high rejection at 450 MHz.

The 12.79-MHz signals in the response and reference channels are converted to a frequency of  $\approx 66$  kHz in a tracking down-converter, then detected by a lock-in amplifier that functions as a variable-bandwidth magnitude and

phase receiver. The bandwidth and gain are controlled by a laptop computer. The vector DC outputs of the lock-in amplifier are read by an analog data-acquisition card in the computer, wherein these readings are converted to polar format. At maximum detection bandwidth, real-time acquisition speeds of  $>3,000$  points per second are possible.

*This work was done by Robert Dengler, Frank Maiwald, and Peter Siegel of Caltech for NASA's Jet Propulsion Laboratory. Further information is contained in a TSP (see page 1).*

*In accordance with Public Law 96-517, the contractor has elected to retain title to this invention. Inquiries concerning rights for its commercial use should be addressed to:*

*Innovative Technology Assets Management  
JPL*

*Mail Stop 202-233  
4800 Oak Grove Drive  
Pasadena, CA 91109-8099  
(818) 354-2240*

*E-mail: iaoffice@jpl.nasa.gov*

*Refer to NPO-43394, volume and number of this NASA Tech Briefs issue, and the page number.*

## Modular Architecture for the Measurement of Space Radiation

**New architecture developed with improved capabilities adds radiation hardness.**

*Lyndon B. Johnson Space Center, Houston, Texas*

A modular architecture has been conceived for the design of radiation-monitoring instruments used aboard spacecraft and in planetary-exploration settings. This architecture reflects lessons learned from experience with prior radiation-monitoring instruments. A prototype instrument that embodies the architecture has been developed as part of the Mars Advanced Radiation Acquisition (MARA) project. The architecture is also applicable on Earth for radiation-monitoring instruments in research of energetic electrically charged particles and instruments monitoring radiation for purposes of safety, military defense, and detection of hidden nuclear devices and materials.

Whereas prior such instruments have contained non-radiation-hardened parts, an instrument according to this architecture is made of radiation-hardened/radiation-tolerant parts, enabling the instrument to resist damage by the radiation that it is intended to measure. One of the building blocks in this modular architecture is a single-channel radiation-detection circuit, which is essentially a detector interface, signal-processing and measurement circuit, dedicated to a single radiation detector that provides radiation-event data to the CPU. The interface between the single-channel radiation-detection circuit and the rest of the instrument is a PC/104 computer-bus interface. [PC/104 is an industry standard for compact, stackable modules that are compatible (in architecture, hardware, and software) with personal-computer data and power-bus circuitry.] Multiple single-channel radiation-detection cir-

cuits can be stacked to create a multiple-detector instrument.

The present architecture as embodied in the MARA instrument design offers the following advantages over the architectures and designs of prior radiation-monitoring systems:

The detector interface circuitry in prior instruments included voltage-feedback operational amplifiers, which do not enable accurate tracking of the rising edges of incoming pulses and, as a result, do not enable deterministic discrimination among different levels of radiation events. In contrast, the MARA circuit design provides the capa-

bility to more accurately differentiate among different types of energetic charged particles.

Unlike prior designs, the MARA design provides for correlated double sampling, which offers the advantage of subtraction of correlated noise between reset samples and data samples, thereby reducing spurious offsets and the effects of low-frequency noise.

Prior designs do not afford enough dynamic range to enable detection of both low- and high-energy events without adjustment by an operator. The MARA design features 16-bit quantization depth, which provides sufficient dynamic range to en-

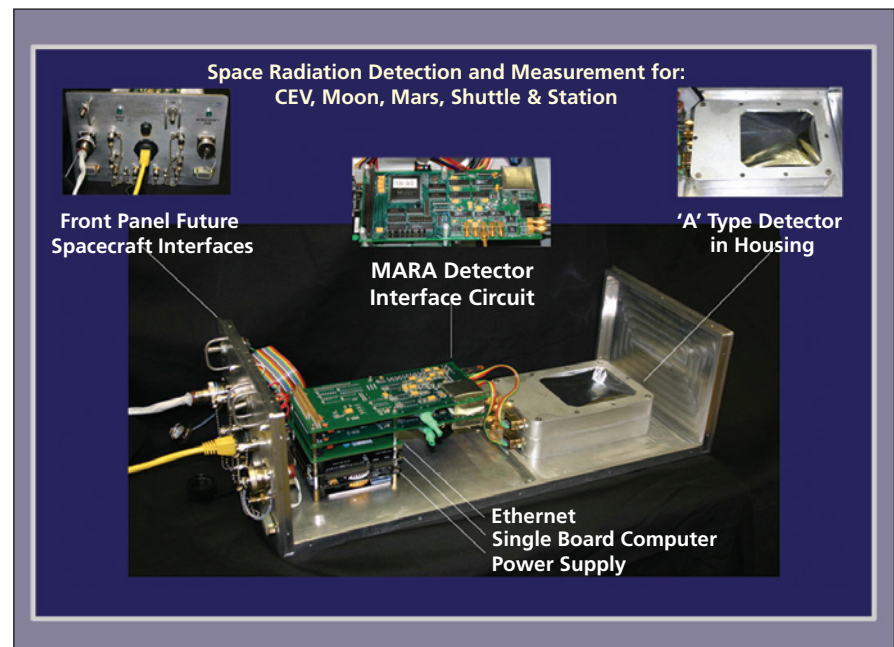

**MARA Instrument Phase I Prototype** is shown in two-detector configuration. (Note: CEV is Crewed Exploration Vehicle.)