



Technology Focus: Test & Measurement

Calibration Test Set for a Phase-Comparison Digital Tracker

Four equal-amplitude signals are generated at selectable phase increments of 0.1° .

NASA's Jet Propulsion Laboratory, Pasadena, California

An apparatus that generates four signals at a frequency of 7.1 GHz having precisely controlled relative phases and equal amplitudes has been designed and built. This apparatus is intended mainly for use in computer-controlled automated calibration and testing of a phase-comparison digital tracker (PCDT) that measures the relative phases of replicas of the same X-band signal received by four antenna elements in an array. (The relative direction

of incidence of the signal on the array is then computed from the relative phases.) The present apparatus can also be used to generate precisely phased signals for steering a beam transmitted from a phased antenna array.

The apparatus (see figure) includes a 7.1-GHz signal generator, the output of which is fed to a four-way splitter. Each of the four splitter outputs is attenuated by 10 dB and fed as input to a vector modu-

lator, wherein DC bias voltages are used to control the in-phase (I) and quadrature (Q) signal components. The bias voltages are generated by digital-to-analog-converter circuits on a control board that receives its digital control input from a computer running a LabVIEW program. The outputs of the vector modulators are further attenuated by 10 dB, then presented at high-grade radio-frequency connectors. The attenuation reduces the effects of changing mismatch and reflections.

The apparatus was calibrated in a process in which the bias voltages were first stepped through all possible IQ settings. Then in a reverse interpolation performed by use of MATLAB software, a lookup table containing 3,600 IQ settings, representing equal amplitude and phase increments of 0.1° , was created for each vector modulator. During operation of the apparatus, these lookup tables are used in calibrating the PCDT.

This work was done by Amy Boas, Samuel Li, and Robert McMaster of Caltech for NASA's Jet Propulsion Laboratory. Further information is contained in a TSP (see page 1). NPO-42813

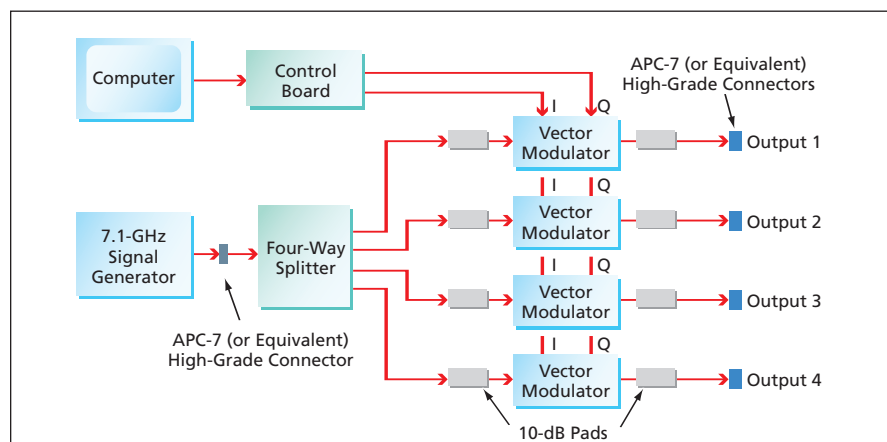

The PCDT Calibration Test Set contains four computer-controlled vector modulators that produced selectively phased replicas of a 7.1-GHz input signal.

Wireless Acoustic Measurement System

This system supplants older, less-capable, cable-connected systems.

Stennis Space Center, Mississippi

A prototype wireless acoustic measurement system (WAMS) is one of two main subsystems of the Acoustic Prediction/ Measurement Tool, which comprises software, acoustic instrumentation, and electronic hardware combined to afford integrated capabilities for predicting and measuring noise emitted by rocket and jet engines. The other main subsystem is described in the article on page 8.

The WAMS includes analog acoustic measurement instrumentation and analog and digital electronic circuitry combined with computer wireless local-area

networking to enable (1) measurement of sound-pressure levels at multiple locations in the sound field of an engine under test and (2) recording and processing of the measurement data. At each field location, the measurements are taken by a portable unit, denoted a field station. There are ten field stations, each of which can take two channels of measurements.

Each field station is equipped with two instrumentation microphones, a micro-ATX computer, a wireless network adapter, an environmental enclosure, a directional radio antenna, and a battery

power supply. The environmental enclosure shields the computer from weather and from extreme acoustically induced vibrations. The power supply is based on a marine-service lead-acid storage battery that has enough capacity to support operation for as long as 10 hours.

A desktop computer serves as a control server for the WAMS. The server is connected to a wireless router for communication with the field stations via a wireless local-area network that complies with wireless-network standard 802.11b of the Institute of Electrical and Electronics Engineers. The router and the

wireless network adapters are controlled by use of Linux-compatible driver software. The server runs custom Linux software for synchronizing the recording of measurement data in the field stations. The software includes a module that provides an intuitive graphical user interface through which an operator at the control server can control the operations of the field stations for calibration and for recording of measurement data.

A test engineer positions and activates the WAMS. The WAMS automatically establishes the wireless network. Next, the engineer performs pretest calibrations. Then the engineer executes the test and measurement procedures. After the test, the raw measurement files are copied and transferred, through the wireless network, to a hard disk in the control server. Subsequently, the data are processed into $\frac{1}{3}$ -octave spectrograms.

This work was done by Paul D. Anderson and Wade D. Dorland of AI Signal Research, Inc., and Ronald L. Jolly of Total Solutions, Inc. for Stennis Space Center.

Inquiries concerning rights for the commercial use of this invention should be addressed to the Intellectual Property Manager, Stennis Space Center, (228) 688-1929. Refer to SSC-00215-2.

⚙️ Spiral Orbit Tribometer

Friction and lubricant degradation rate can be quantified rapidly.

John H. Glenn Research Center, Cleveland, Ohio

The spiral orbit tribometer (SOT) bridges the gap between full-scale life testing and typically unrealistic accelerated life testing of ball-bearing lubricants in conjunction with bearing ball and race materials. The SOT operates under realistic conditions and quickly produces results, thereby providing information that can guide the selection of lubricant, ball, and race materials early in a design process.

The SOT is based upon a simplified, retainerless thrust bearing comprising one ball between flat races (see figure). The SOT measures lubricant consumption and degradation rates and friction coefficients in boundary lubricated rolling and pivoting contacts.

The ball is pressed between the lower and upper races with a controlled force and the lower plate is rotated. The combination of load and rotation causes the ball to move in a nearly circular orbit that is, more precisely, an opening spiral. The spiral's pitch is directly related to the friction coefficient. At the end of the orbit, the ball contacts the guide plate, restoring the orbit to its original radius. The orbit is repeatable throughout the entire test. A force transducer, mounted in-line with the guide plate, measures the force between the ball and the guide plate, which directly relates to the friction coefficient. The SOT, shown in the figure, can operate in under ultra-high vacuum (10^{-9} Torr) or in a variety of gases at atmospheric pressure. The load force can be adjusted between 45 and 450 N. By varying the load force and ball diameter, mean Hertzian stresses between 0.5 and 5.0 GPa can be obtained. The ball's orbital speed range is between 1 and 100 rpm.

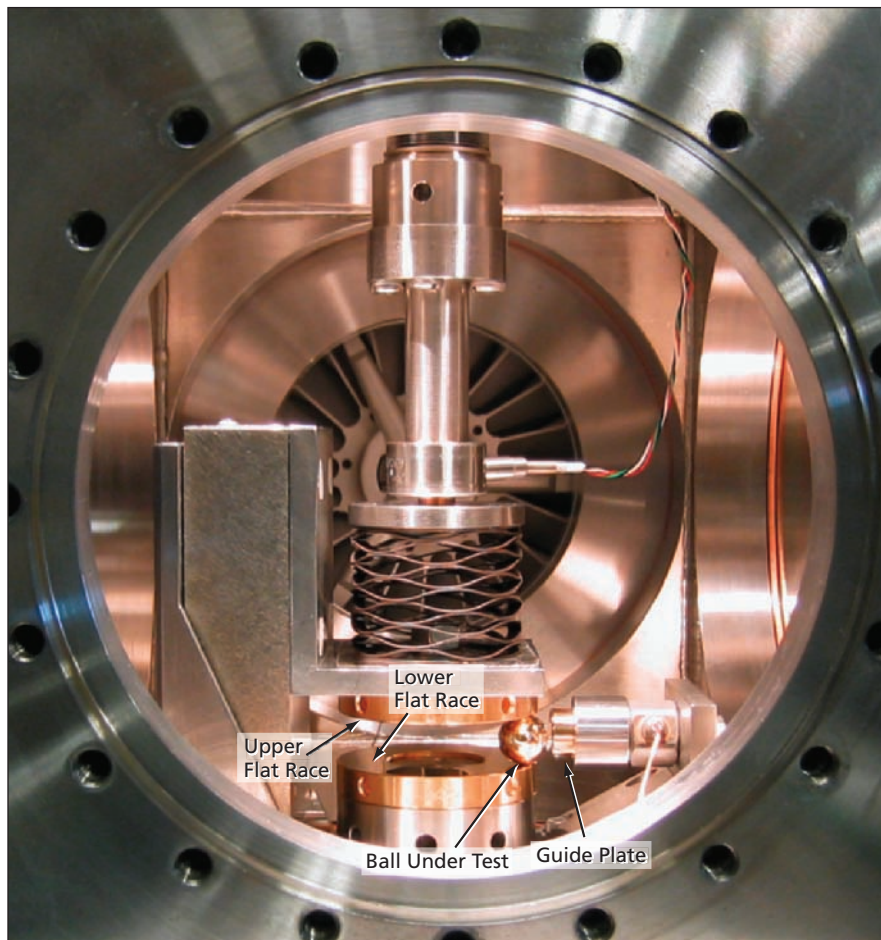

The **Spiral-Orbit Tribometer** is based on a retainerless flat thrust bearing. The ball is squeezed between the upper and lower flat races while the lower flat race is rotated, causing the ball to orbit in an opening spiral.

For most of the orbit, the ball undergoes pure rolling with pivot; however, when the ball contacts the guide plate, sliding also occurs. The period of contact with the guide plate, termed the "scrub," is the most tribologically severe part of the orbit and is when the majority of the lubricant's tribo-degradation occurs.

Typically, a small amount of lubricant ($\approx 50 \mu\text{g}$) is applied to the ball at the beginning of a test. Such a minute lubricant amount usually degrades within one or two days. The test duration can be varied by adjusting the initial amount of lubricant and/or the load force. A test is terminated when the lu-