

LDPC Codes With Minimum Distance Proportional to Block Size

These codes offer both low decoding thresholds and low error floors.

NASA's Jet Propulsion Laboratory, Pasadena, California

Low-density parity-check (LDPC) codes characterized by minimum Hamming distances proportional to block sizes have been demonstrated. Like the codes mentioned in the immediately preceding article, the present codes are error-correcting codes suitable for use in a variety of wireless data-communication systems that include noisy channels.

The previously mentioned codes have low decoding thresholds and reasonably low error floors. However, the minimum Hamming distances of those codes do not grow linearly with code-block sizes. Codes that have this minimum-distance property exhibit very low error floors. Examples of such codes include regular LDPC codes with variable degrees of at least 3. Unfortunately, the decoding thresholds of regular LDPC codes are high. Hence, there is a need for LDPC codes characterized by both low decoding thresholds and, in order to obtain acceptably low error floors, minimum Hamming distances that are proportional to code-block sizes.

The present codes were developed to satisfy this need. The minimum Hamming distances of the present codes have been shown, through consideration of ensemble-average weight enumerators, to be proportional to code block sizes. As in the cases of irregular ensembles, the properties of these codes are sensitive to the proportion of degree-2 variable nodes. A code having too few such nodes tends to have an iterative decoding threshold that is far from the capacity threshold. A code having too many such nodes tends not to exhibit a minimum distance that is proportional to block size.

Results of computational simulations have shown that the decoding thresholds of codes of the present type are lower than those of regular LDPC codes. Included in the simulations were a few examples from a family of codes characterized by rates ranging from low to high and by thresholds that adhere closely to their respective channel capacity thresholds; the simulation results from these

examples showed that the codes in question have low error floors as well as low decoding thresholds.

As an example, the illustration shows the protograph (which represents the blueprint for overall construction) of one proposed code family for code rates greater than or equal to $\frac{1}{2}$. Any size LDPC code can be obtained by copying the protograph structure N times, then permuting the edges. The illustration also provides Field Programmable Gate Array (FPGA) hardware performance simulations for this code family. In addition, the illustration provides minimum signal-to-noise ratios (E_b/N_0) in decibels (decoding thresholds) to achieve zero error rates as the code block size goes to infinity for various code rates. In comparison with the codes mentioned in the preceding article, these codes have slightly higher decoding thresholds.

The present codes offer one main disadvantage with respect to the codes described previously: These codes do not

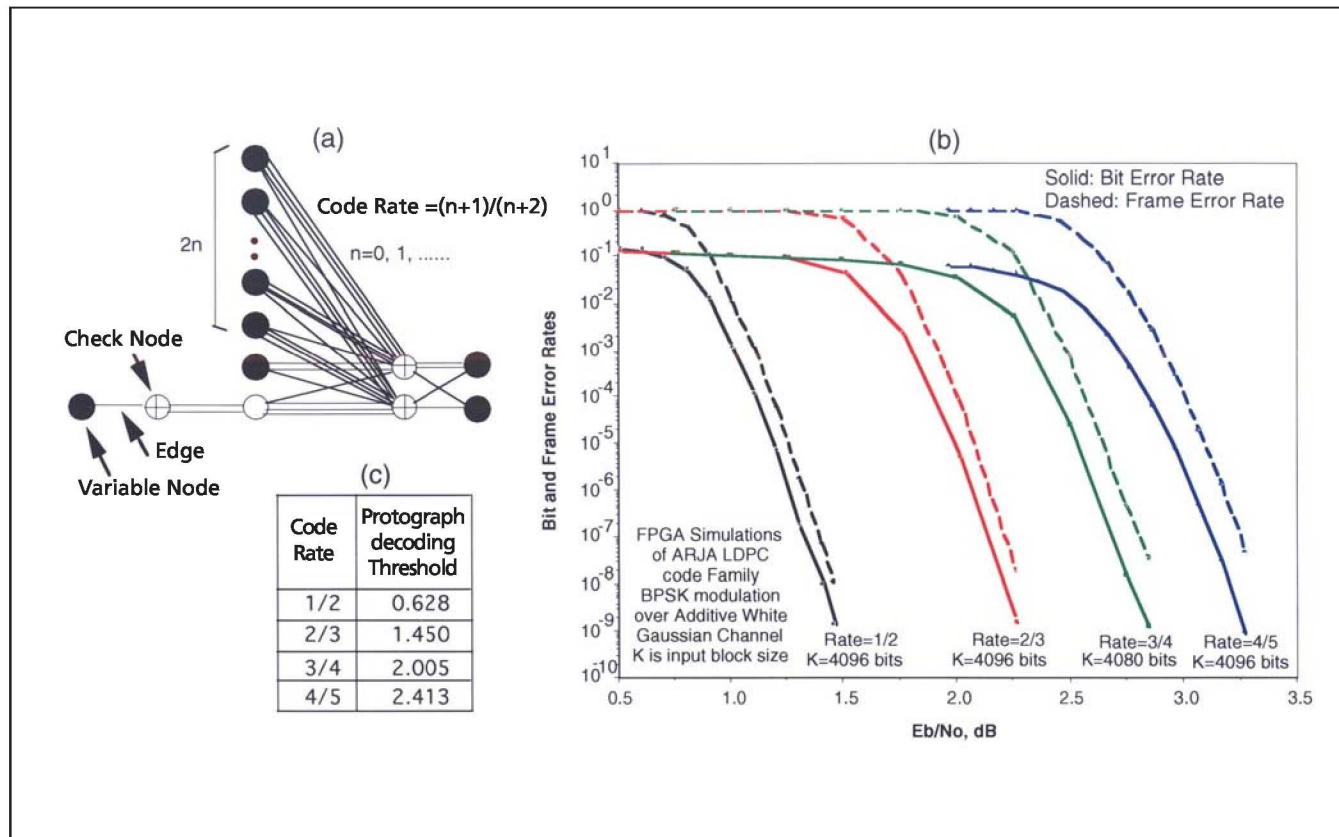

Accumulate-Repeat-Jagged-Accumulate (ARJA) LDPC Code Family is illustrated as follows: (a) protograph, (b) performance of FPGA hardware decoder, and (c) decoding thresholds.

lend themselves to computationally efficient structures that can be implemented in high-speed encoder hardware. However, high-speed encoder implementation can be expected to be a subject of future research.

This work was done by Dariush Divsalar, Christopher Jones, Samuel Dolinar, and Je-

remy Thorpe of Caltech for NASA's Jet Propulsion Laboratory.

In accordance with Public Law 96-517, the contractor has elected to retain title to this invention. Inquiries concerning rights for its commercial use should be addressed to:

*Innovative Technology Assets Management
JPL*

*Mail Stop 202-233
4800 Oak Grove Drive
Pasadena, CA 91109-8099
(818) 354-2240*

*E-mail: iaoffice@jpl.nasa.gov
Refer to NPO-42063, volume and number of this NASA Tech Briefs issue, and the page number.*

➤ Constructing LDPC Codes From Loop-Free Encoding Modules

High-speed iterative decoders can readily be implemented in hardware.

NASA's Jet Propulsion Laboratory, Pasadena, California

A method of constructing certain low-density parity-check (LDPC) codes by use of relatively simple loop-free coding modules has been developed. The subclasses of LDPC codes to which the method applies includes accumulate-repeat-accumulate (ARA) codes, accumulate-repeat-check-accumulate codes, and the codes described in "Accumulate-Repeat-Accumulate-Accumulate Codes" (NPO-41305), *NASA Tech Briefs*, Vol. 31, No. 9 (September 2007), page 90. All of the affected codes can be characterized as serial/parallel (hybrid) concatenations of such relatively simple modules as accumulators, repetition codes, differentiators, and punctured single-parity check codes. These are error-correcting codes suitable for use in a variety of wireless data-communication systems that include noisy channels. These codes can also be characterized as hybrid turbo-like codes that have projected graph or protograph representations (for example see figure); these characteristics make it possible to design high-speed iterative decoders that utilize belief-propagation algorithms.

The present method comprises two related submethods for constructing LDPC codes from simple loop-free modules with circulant permutations. The first submethod is an iterative encoding method based on the erasure-decoding algorithm. The computations required by this method are well organized because they involve a parity-check matrix having a block-circulant structure.

The second submethod involves the use of block-circulant generator matrices. The encoders of this method are very similar to those of recursive convolutional codes. Some encoders according to this second submethod have been implemented in a small field-programmable gate array that operates at a speed of 100 megasymbols per second.

By use of density evolution (a computational-simulation technique for analyzing performances of LDPC codes), it has been shown through some examples that as the block size goes to infinity, low iterative decoding thresholds close to channel capacity limits can be achieved for the codes of the type in question having low maximum variable node de-

grees. The decoding thresholds in these examples are lower than those of the best-known unstructured irregular LDPC codes constrained to have the same maximum node degrees. Furthermore, the present method enables the construction of codes of any desired rate with thresholds that stay uniformly close to their respective channel capacity thresholds.

This work was done by Dariush Divsalar, Samuel Dolinar, Christopher Jones, Jeremy Thorpe, and Kenneth Andrews of Caltech for NASA's Jet Propulsion Laboratory.

In accordance with Public Law 96-517, the contractor has elected to retain title to this invention. Inquiries concerning rights for its commercial use should be addressed to:

*Innovative Technology Assets Management
JPL*

*Mail Stop 202-233
4800 Oak Grove Drive
Pasadena, CA 91109-8099
(818) 354-2240*

*E-mail: iaoffice@jpl.nasa.gov
Refer to NPO-42042, volume and number of this NASA Tech Briefs issue, and the page number.*

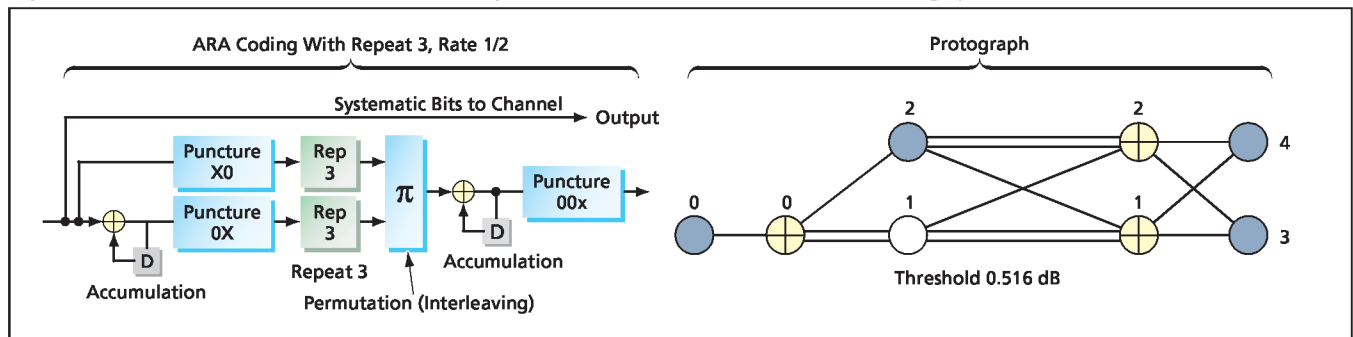

A Simple Rate-1/2 ARA Code is depicted here with its protograph representation as an example of codes to which the present method applies. An encoder for this code includes a precoder in the form of a punctured accumulator.