

NASA/TM-2009-214180

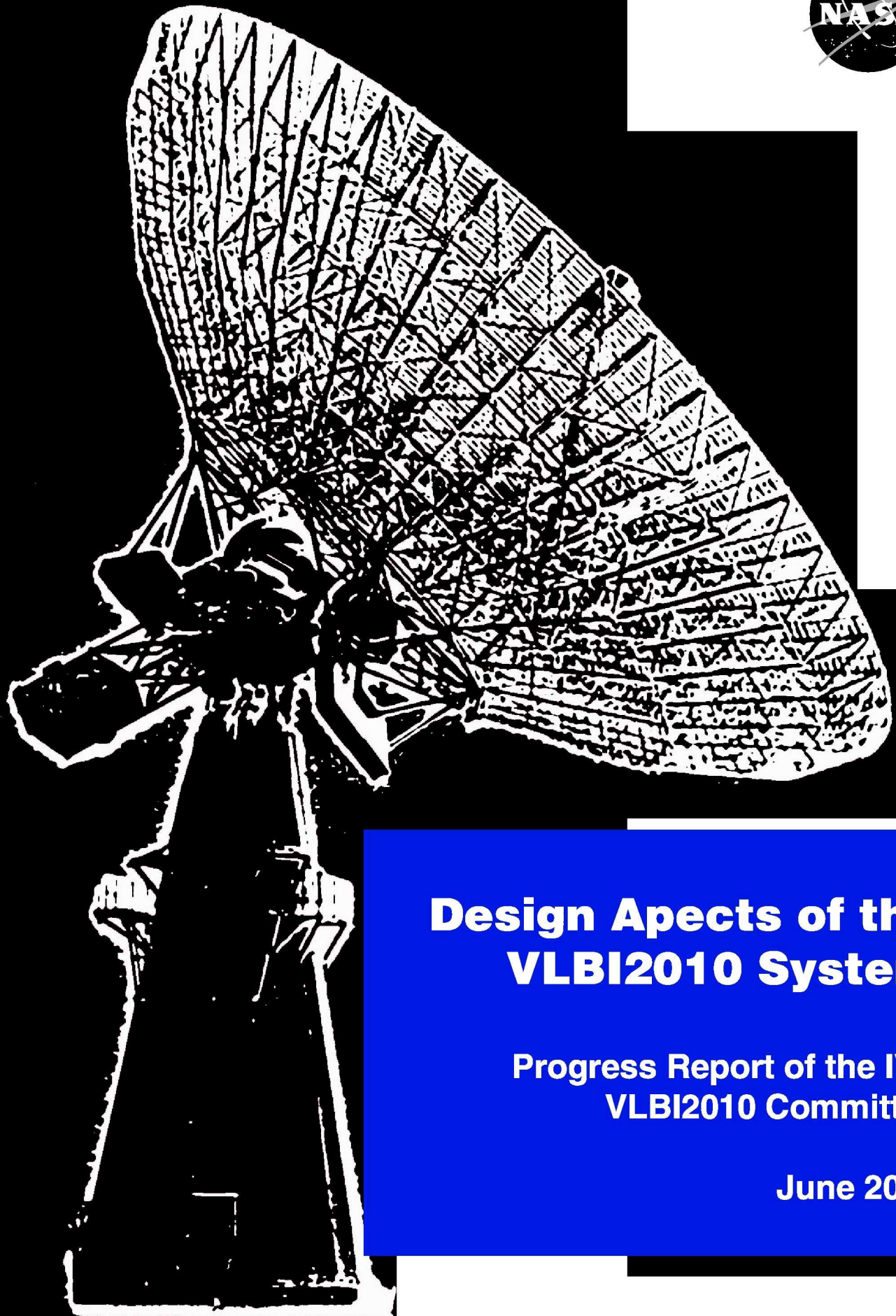
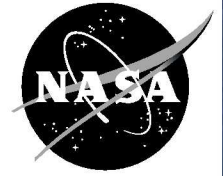

Design Apects of the VLBI2010 System

**Progress Report of the IVS
VLBI2010 Committee**

June 2009



Design Aspects of the VLBI2010 System

Progress Report of the IVS VLBI2010 Committee

Bill Petrachenko (chair), Natural Resources Canada, Penticton, BC, CANADA
Arthur Niell, Haystack Observatory, Massachusetts Institute of Technology, Westford, MA
Dirk Behrend, NVI, Inc./Goddard Space Flight Center, Greenbelt, MD
Brian Corey, Haystack Observatory, Massachusetts Institute of Technology, Westford, MA
Johannes Böhm, Institute of Geodesy Geophysics, University of Technology, Vienna, AUSTRIA
Patrick Charlot, Bordeaux Observatory, France
Arnaud Collioud, Bordeaux Observatory, France
John Gipson, NVI, Inc./Goddard Space Flight Center, Greenbelt, MD
Rüdiger Haas, Onsala Space Observatory, Chalmers University of Technology, Onsala, SWEDEN
Thomas Hobiger, Kashima Space Research Center, NICT, Kashima, JAPAN
Yasuhiro Koyama, Kashima Space Research Center, NICT, Kashima, JAPAN
Dan MacMillan, NVI, Inc./Goddard Space Flight Center, Greenbelt, MD
Zinovy Malkin, Pulkovo Observatory, St. Petersburg, RUSSIA
Tobias Nilsson, Onsala Space Observatory, Chalmers University of Technology, Onsala, SWEDEN
Andrea Pany, Institute of Geodesy and Geophysics, University of Technology, Vienna, AUSTRIA
Gino Tuccari, Radio Astronomy Institute, Italian National Astrophysical Institute, Noto, ITALY
Alan Whitney, Haystack Observatory, Massachusetts Institute of Technology, Westford, MA
Jörg Wresnik, Institute of Geodesy and Geophysics, University of Technology, Vienna, AUSTRIA

National Aeronautics and
Space Administration

**Goddard Space Flight Center
Greenbelt, Maryland 20771**

June 2009

Design Aspects of the VLBI2010 System

Progress Report of the IVS VLBI2010 Committee

Bill Petrachenko¹ (chair), Arthur Niell², Dirk Behrend³, Brian Corey²,
Johannes Böhm⁴, Patrick Charlot⁵, Arnaud Collioud⁵, John Gipson³,
Rüdiger Haas⁶, Thomas Hobiger⁷, Yasuhiro Koyama⁷, Dan MacMillan³,
Zinovy Malkin⁸, Tobias Nilsson⁶, Andrea Pany⁴, Gino Tuccari⁹,
Alan Whitney², Jörg Wresnik⁴

¹*Natural Resources Canada, Canada*

²*Haystack Observatory, Massachusetts Institute of Technology, USA*

³*NVI, Inc./Goddard Space Flight Center, USA*

⁴*Institute of Geodesy and Geophysics, University of Technology, Vienna, Austria*

⁵*Bordeaux Observatory, France*

⁶*Onsala Space Observatory, Chalmers University of Technology, Sweden*

⁷*Kashima Space Research Center, NICT, Japan*

⁸*Pulkovo Observatory, Russia*

⁹*Radio Astronomy Institute, Italian National Astrophysical Institute, Italy*

April 17, 2009

Executive Summary

In September 2005 the IVS Directing Board accepted the final report of its Working Group 3 (WG3) entitled “VLBI2010: Current and Future Requirements for Geodetic VLBI Systems”. This bold vision for the future recommended a review of all current VLBI systems and processes from antennas to analysis and outlined a path to a next-generation system with unprecedented new capabilities:

- 1-mm position accuracy on global scales,
- continuous measurements for time series of station positions and Earth orientation parameters,
- turnaround time to initial geodetic results of less than 24 hours.

Immediately following the acceptance of the WG3 final report, the IVS established the VLBI2010 Committee (V2C) to carry out a series of studies recommended by WG3 and to encourage the realization of the new vision for geodetic VLBI. Since its inception, the V2C has accomplished much towards this goal. This report summarizes the work of the committee through the end of 2008.

Monte Carlo simulations. Making rational design decisions for VLBI2010 requires an understanding of the impact of new strategies on the quality of VLBI products. Monte Carlo simulators were developed to serve this purpose. They have been used to study the effects of the dominant VLBI random error processes (related to the atmosphere, the reference clocks, and the delay measurement noise) and the benefit of new approaches to reduce them, such as decreasing the source-switching interval and improving analysis and scheduling strategies. Of particular merit is shortening the source-switching interval, which results in a nearly proportionate improvement in station position accuracy. Regardless of the strategy employed, the simulators also confirm that the dominant error source is the atmosphere. It is recommended that research into better ways to handle the atmosphere continues to be a priority for the IVS.

System considerations, system description, and NASA proof-of-concept test. Based on the Monte Carlo studies, a high priority is placed on finding strategies for reducing the source-switching interval. This entails decreasing both the on-source time needed to make a precise delay measurement and the time required to slew between sources. From these two somewhat competing goals, recommendations for the VLBI2010 antennas are emerging, e.g., either a single 12-m diameter antenna with very high slew rates, e.g., 12°/s in azimuth, or a pair of 12-m diameter antennas, each with more moderate slew rates, e.g., 5°/s in azimuth.

In order to shorten the on-source observing time, it is important to find a means for measuring the delay with the requisite precision even at a modest signal-to-noise ratio. To do this a new approach is being developed in which several widely spaced frequency bands are used to unambiguously resolve the interferometric phase. The new observable is being referred to as the broadband delay. A four-band system is recommended that uses a broadband feed to span the entire frequency range from 2 to 14 GHz. In order to detect an adequate number of high-quality radio sources, a total instantaneous data rate as high as 32 Gbps and a sustained data storage or transmission rate as high as 8 Gbps are necessary. Since the broadband delay technique is new and untested, NASA is funding a proof-of-concept effort. First fringes have been detected in all bands.

It is also recognized that reducing systematic errors plays a critical role in improving VLBI accuracy. For electronic biases, updated calibration systems are being developed. For antenna deformations, conventional surveying techniques continue to be refined, while the use of a small reference antenna for generating deformation models and establishing site ties is also under consideration. For errors due to source structure, the application of corrections based on images derived directly from the VLBI2010 observations is under study.

Operational considerations. It is recommended that a globally distributed network of at least 16 VLBI2010 antennas observes every day to determine Earth orientation parameters, and that other antennas be added as needed for the maintenance of the celestial and terrestrial reference frames. A subset of antennas with access to high-speed fiber networks is also required to enable daily delivery of initial IVS products in less than 24 hours. A high priority is placed on increasing the number of stations in the southern hemisphere. Since IVS products must be delivered without interruption, a transition period to VLBI2010 operations is required in which there will be a mix of antennas with current and next-generation receiving systems. For this period a compatibility mode of operation has been identified and tested to a limited extent with the NASA proof-of-concept system. In order to increase reliability and to reduce the cost of operations, enhanced automation will be introduced both at the stations and in the analysis process. Stations will be monitored centrally to ensure compatible operating modes, to update schedules as required, and to notify station staff when problems occur. Automation of the analysis process will benefit from the work of IVS Working Group 4, which is updating data structures and modernizing data delivery.

Risks and fallback options. There are a number of risks to successful implementation of VLBI2010, the most significant of which follow.

- Because of the smaller size of the VLBI2010 antenna and greater density of observations, a significant increase in data volume and hence shipping and/or transmission costs is anticipated. It is expected that future technological advances will reduce these costs. In the interim less data-intensive operating modes may be employed.
- Radio frequency interference (RFI) is an ever increasing problem in the VLBI2010 spectrum. Fortunately, VLBI is comparatively insensitive to RFI, and the VLBI2010 system is being designed to be resilient against it.
- The broadband delay technique has not been demonstrated. Known risks come from RFI and source structure. The NASA proof-of-concept test is now poised to make its first broadband observations to verify the feasibility of the new technique. In the event that problems are identified, less attractive but adequate fallback options have been defined.
- VLBI2010 is now well on the way to definition of requirements and recommendations for subsystem specifications. However, the current rather informal organization through the V2C may not be adequate to move to the next level of defining development and deployment schedules and soliciting contributions. It is recommended that a small project coordinating executive group be established.

Next steps.

- Continue the NASA proof-of-concept effort.
- Continue defining subsystem recommendations.
- Promote the expansion of the VLBI2010 network.
- Develop a short-baseline research network.
- Begin development and testing of a small reference antenna for generating antenna deformation models and automatic site tie procedures.
- Improve algorithms for scheduling observations.
- Extend the source structure studies to the analysis of real S/X data.
- Develop VLBI2010 analysis strategies including automation.

Table of Contents

1	Introduction.....	1
1.1	Background.....	1
1.2	Overview of the Report.....	1
2	Monte Carlo Simulations.....	1
2.1	Description of the V2C Monte Carlo Simulators.....	2
2.2	Scheduling Strategies.....	3
2.3	Source-switching Interval.....	4
2.4	Analysis Strategies.....	5
2.5	Random Errors.....	5
2.6	Network Size.....	7
2.7	Validation of the Monte Carlo Simulators.....	7
2.8	Other Considerations.....	8
3	System Considerations.....	9
3.1	Sensitivity.....	9
3.2	Antenna Slew Rate.....	10
3.3	Delay Measurement Error and the Broadband Delay Concept.....	13
3.4	Radio Frequency Interference (RFI).....	13
3.5	Frequencies.....	14
3.6	Antenna Deformations.....	15
3.7	Source Structure Corrections.....	16
3.7.1	Imaging Capabilities of the VLBI2010 System.....	17
3.7.2	Structure Corrections Based on VLBI2010 Images.....	17
3.7.3	Relative Alignment of the Images in Different Bands.....	18
3.7.4	Identifying a Position Reference for the Source.....	19
4	System Description.....	19
4.1	System Overview.....	19
4.2	Network Recommendations.....	21
4.3	Station Recommendations.....	22
4.4	Recommendations for Antenna Specifications.....	24
4.5	Antenna Feed.....	26
4.6	Polarization.....	27
4.7	Phase and Cable Calibration.....	27
4.8	Noise Calibration.....	28
4.9	Digital Back End (DBE) Functions.....	28
4.10	Correlator.....	30
5	NASA Proof-of-Concept Demonstration.....	30
5.1	Description of the NASA Broadband Delay Proof-of-Concept System.....	30
5.2	Results and Current Status.....	32
5.3	Plans.....	33
6	Operational Considerations.....	34
6.1	Observing Strategy.....	34
6.2	Transition Plan.....	35
6.3	System Automation.....	35
6.4	Analysis Automation.....	36
6.5	New Data Structures.....	37
6.6	Shipping and Media Requirements.....	38
6.7	e-VLBI.....	39

7	Risks and Fallback Options	39
7.1	Technical Risks.....	39
7.2	Organizational Challenges.....	41
8	Next Steps.....	41
	Acknowledgements.....	43
	References.....	44
	Appendices.....	49
	Appendix A. Structure Constants and Wet Effective Heights.....	49
	Appendix B. Glossary.....	51

1 Introduction

1.1 Background

In September 2003 the IVS, recognizing the limitations of existing VLBI infrastructure and the increasingly demanding requirements of space geodesy, established Working Group 3 (WG3): VLBI2010 ([Niell et al., 2006](#)) to investigate options for modernization.

Guided by emerging space geodesy science and operational needs, WG3 established challenging goals for the next generation VLBI system, including:

- 1 mm position accuracy on global scales,
- continuous measurements for time series of station positions and Earth orientation parameters,
- turnaround time to initial geodetic results of less than 24 hours.

In its final report, WG3 proposed strategies to move toward the unprecedented 1 mm position accuracy target and broad recommendations for a next generation system based on the use of smaller (~12 m) fast-slewing automated antennas. To help make these recommendations more specific, the report additionally suggested a series of 13 studies and development projects. In order to encourage the realization of the WG3 recommendations, the IVS established the VLBI2010 Committee (V2C) in September 2005. This report summarizes the work of the committee through the end of 2008.

1.2 Overview of the Report

In Section 2 of this report, Monte Carlo simulators developed by the V2C are described, along with their application in studies to better understand the response of the VLBI system to error processes and to determine the benefit of proposed strategies for improving performance. In Section 3 the implications of these studies and known systematic errors for system design are considered. Section 4 describes the current definition of the VLBI2010 system and Section 5 describes the status of the NASA broadband delay proof-of-concept effort. In Section 6 operational considerations for VLBI2010 are presented. Section 7 treats risks to the successful implementation of VLBI2010 and fallback options for those risks. Section 8 proposes next steps for the project.

2 Monte Carlo Simulations

Rational design decisions for VLBI2010 must be based on a realistic understanding of the impacts of new operating modes on final products. These impacts are difficult to evaluate analytically due to complex interactions in the VLBI analysis process and are impractical to evaluate with real data due to the high cost of VLBI systems and operations ([Petrachenko, 2005](#)).

To fill this gap, the V2C developed Monte Carlo simulators. These simulators have subsequently been used extensively to study the strategies suggested in the IVS WG3 final report ([Niell et al., 2006](#)) for reaching the VLBI2010 target of 1 mm position accuracy.

In this section the V2C Monte Carlo simulators are described, and results of the simulation studies are summarized. The studies include investigations of the impact on final products of:

- scheduling strategies,
- source-switching interval,
- analysis strategies,

- random error sources, including:
 - variations in the rates of the VLBI reference clocks,
 - errors in the delay observable measurements,
 - delays due to the wet atmosphere above each antenna,
- network size.

In Section 2.7 the simulators are validated in a comparison with real data, and in Section 2.8 some inferences for future VLBI systems and observing strategies are drawn from the simulation results.

2.1 Description of the V2C Monte Carlo Simulators

The concept of a Monte Carlo simulator is simple. Several sets of input data are generated analytically from realistic models for the error processes, with each set driven by different random numbers. All data sets are then processed as if they were from real sessions, and the ensemble of output products is analyzed statistically to produce estimates of the bias and standard deviation of those products.

In the particular case of the V2C Monte Carlo simulators, the stochastic processes included are those related to the reference clocks, the wet atmosphere, and the delay measurement noise. The relation of these processes to the ‘observed minus computed’ (*o-c*) VLBI delay observables is expressed in Equation (2-1):

$$(o - c) = (zwd_2 \cdot mfw_2 + clk_2) - (zwd_1 \cdot mfw_1 + clk_1) + wn \quad (2-1)$$

The parameters zwd_1 and zwd_2 are the zenith wet delays at stations 1 and 2, respectively, mfw_1 and mfw_2 are the wet mapping functions, clk_1 and clk_2 are the clock values, and wn is the white noise added per baseline observation to account for the instrumental thermal noise. No other error sources (either random or systematic) are currently incorporated into the Monte Carlo simulators.

The simulated zenith wet delays are based on a turbulence model following [Nilsson et al. \(2007\)](#). A detailed description of the model, together with values for the structure constants Cn , effective wet heights H , and wind velocities \vec{v} , is provided in Appendix A. The wet mapping functions mfw are assumed to be perfectly known, as are the hydrostatic delays. Clocks are simulated as the sum of a random walk and an integrated random walk, both corresponding to a certain Allan Standard Deviation (ASD) (Herring et al., 1990). Source code for the simulation of clock values and the wet delays is provided by [Böhm et al. \(2007\)](#).

VLBI2010 Monte Carlo simulations are based on a set of twenty-five 24-hour sessions; i.e., for each observing schedule, 25 sessions of artificial observations (*o-c*) are generated. All parameters, such as Cn , H , \vec{v} , and clock ASD, are identical for each session, and only the random numbers driving the processes are changed. Geodetic parameters such as station coordinates are estimated for each session, and the biases and standard deviations of the estimates are calculated for the ensemble of 25 sessions.

Monte Carlo simulations have been carried out with three estimation packages:

- *Solve* ([MacMillan, 2006](#)) at the Goddard Space Flight Center,
- *OCCAM* ([Wresnik and Böhm, 2006](#)) at the Institute of Geodesy and Geophysics (IGG) in Vienna,
- Precise Point Positioning (PPP) ([Pany et al., 2008a](#)) at the IGG in Vienna.

While the *Solve* solutions are determined by a classical least-squares adjustment (Gauss-Markov model) and the *OCCAM* solutions are determined with a Kalman filter, the PPP software can do both classical least-squares adjustments and Kalman filter solutions. Although the PPP software is somewhat unrealistic for VLBI, since it treats only one antenna at a time, the results generally agree well with the more complete solutions of *Solve* and *OCCAM*. PPP has the advantage of being easy to enhance for new processing modes.

The Monte Carlo simulators are only as realistic as the models used to generate the simulated input data. Efforts continue to improve those models ([Nilsson and Haas, 2008](#); [MacMillan, 2008](#); [Wresnik et al., 2008a](#)). Effects such as thermal and gravitational deformations of the antennas, source structure, mapping-function errors, hydrostatic atmosphere errors (Böhm et al., 2006; [Niell, 2006a](#)), and errors in the geophysical models are not modeled in the simulators. Those effects are instead addressed through careful system design, calibration, and external measurements (Sections 3 and 4).

2.2 Scheduling Strategies

Traditionally, the stochastic behaviors of both the wet component of the atmosphere and the hydrogen maser reference oscillators have been extracted directly from the VLBI data. The separation of these effects from the geometric parameters of interest has been achieved through the use of optimized schedules in which source direction varies significantly during the course of each stochastic estimation interval.

New VLBI2010 operating modes will require a different conceptualization of scheduling strategies. In particular, the anticipated use of globally distributed networks and ultra-short source-switching intervals opens interesting new scheduling possibilities, two of which have been investigated to date.

The first possibility is a straightforward extension of the well-known Goddard Space Flight Center (GSFC) scheduling program, *sked*, which is currently used operationally to schedule IVS sessions. The primary goal for the new *sked* VLBI2010 optimization is to maximize the total number of observations in a session. Principal criteria for generating these schedules are:

- maximization of the number of stations in a scan,
- minimization of slew times between scans.

Although the latter condition results in sources being observed in clusters, it was reasoned that the short source-switching intervals would lead to sufficiently large clusters to achieve adequate sky coverage at each station over a short period of time.

At Natural Resources Canada (NRCan) a second effort was initiated to produce schedules guaranteed to have uniform sky coverage over short intervals. Principal rules for generating these schedules are:

- regular source-switching intervals,
- simultaneous observation of two sources roughly 180° apart with nearly all stations being able to see either one source or the other at any given time,
- uniform coverage of the celestial sphere over short intervals.

Both scheduling strategies have been evaluated extensively by the V2C. Their performance with respect to position error is nearly identical. However, the regular source-switching intervals used by the uniform sky schedules enable a more generalized study of antenna slew rate requirements.

For consistency, the uniform sky schedules have been used exclusively in the studies reported in this document.

For the practical generation of the schedules, catalogs of suitable radio sources and stations are required. A list of 230 strong, nearly structureless radio sources, which was developed by Leonid Petrov specifically for geodetic applications ([Petrov, 2007](#)), is the basis for all schedules used in these studies.

With respect to stations, hypothetical networks of 16, 24, and 32 stations were developed specifically for the Monte Carlo studies ([Niell, 2007](#)). The primary criterion for the networks was to approach a uniform global distribution, although realism was introduced by requiring that the stations be on land near existing International GNSS Service (IGS) stations. Due to the paucity of continental land-mass in the southern hemisphere, the distribution of stations is worse there than in the north.

Research into scheduling strategies remains a priority for VLBI2010. A corresponding research project has been funded and will start at IGG Vienna in January 2009.

2.3 Source-switching Interval

In the WG3 final report ([Niell et al., 2006](#)) it was proposed that the source-switching interval be decreased dramatically. To test the impact of this strategy on performance, eight uniform sky schedules were generated with regular source-switching intervals of 15, 30, 45, 60, 90, 120, 240, and 360 s. The upper limit of 360 s was chosen to represent performance typical of current observations.

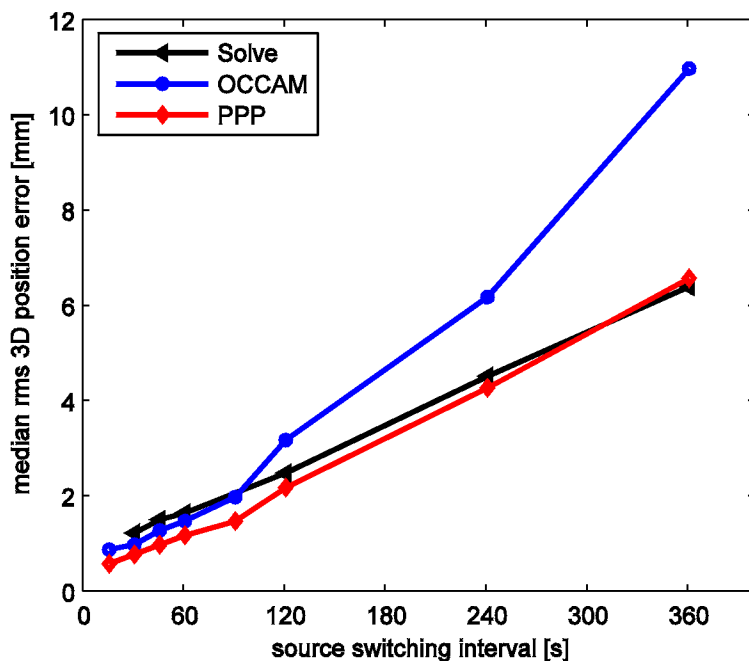

Figure 2-1. Median of the rms 3D position errors for uniform sky schedules with regular source-switching intervals ranging from 15 to 360 s. The delay measurement noise was 4 ps per baseline observation, the clock Allan Standard Deviation was $1 \cdot 10^{-14}$ @ 50 minutes, and the turbulence parameters were those tabulated in Appendix A. It is believed that the poorer performance of *OCCAM* at longer intervals is due to the fact that its Kalman filter solutions were specifically tuned for shorter source-switching intervals.

The primary quantity that has been used throughout the simulation studies to characterize performance is the median of the rms 3D position errors for the network for a 24-hour session. This is shown in Figure 2-1 to 2-5 for a 16-station network.

In Figure 2-1 the trends of the curves for the three analysis packages indicate impressive improvement from the longest to the shortest source-switching interval. For this reason the results in Figure 2-1 are used in Sections 3.1 and 3.2 as important constraints for recommendations of system parameters, such as sustained data rate, antenna diameter, and slew rates.

2.4 Analysis Strategies

The new VLBI2010 operating modes, with their greater observation density, more precise delay observables, and larger number of stations per scan, have stimulated a review of optimal analysis. The two most important findings are summarized below.

- *Shorter atmosphere estimation intervals.* For Gauss-Markov least-squares analysis, having many more observations per unit time enables the use of shorter atmosphere estimation intervals for zenith wet delays and gradients. For stations near the equator, where there is more water vapor in the atmosphere, the reduction in error can approach a factor of two, although elsewhere it is typically considerably less.
- *Elevation angle weighting.* The relative contribution of atmosphere model errors is enhanced at low-elevation angles as delay precision improves. The impact can be reduced by downweighting low-angle observations. For analyses carried out with weights of $mfw \cdot 10$ ps added in quadrature to the observation sigma, improvement was found to be largest at about 30% for equatorial stations. A more general atmosphere treatment that includes spatial correlations of observables ([Treuhaft and Lanyi, 1987](#)) should be studied with the Monte-Carlo simulators in the future.

Other analysis options have also been tried, e.g., larger a priori variance-rates for the atmosphere and clocks in the Kalman filter and low-order spherical harmonics for the atmosphere ([Pany et al., 2008c](#)).

2.5 Random Errors

As pointed out in Section 2.1, the three main random error sources impacting VLBI results are the variations in the rates of the reference clocks, the delay measurement noise, and the delay of the atmosphere above the stations. In this section we investigate the impact of these error sources one at a time. The following values have been used as defaults in this section.

Clock:	Allan Standard Deviation (ASD) of $1 \cdot 10^{-14}$ @ 50 minutes
Delay measurement noise:	white noise of 4 ps per baseline observation
Turbulence:	structure constant $C_n = 1 \cdot 10^{-7} \text{ m}^{-1/3}$ effective wet height $H = 2$ km wind velocity $\vec{v} = 10$ m/s towards east

The default ASD comes from the analysis of real VLBI sessions, the delay measurement noise is the value anticipated for VLBI2010, and the turbulence values are those suggested by [Treuhaft and Lanyi \(1987\)](#). All analyses used the same 16-station uniform sky schedule with a source-switching interval of 60 s.

The sensitivity analyses were carried out with all three packages. Detailed descriptions of the analyses are provided by [MacMillan and Sharma \(2008\)](#) for the *Solve* solution, by [Wresnik et al. \(2008b\)](#) for the *OCCAM* solution, and by [Pany et al. \(2008b\)](#) for the PPP solution. Major results of these studies are summarized below.

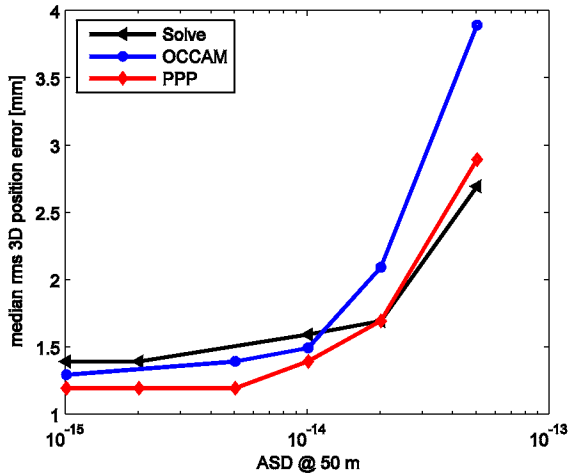

Figure 2-2. Median of the rms 3D position errors versus clock ASD.

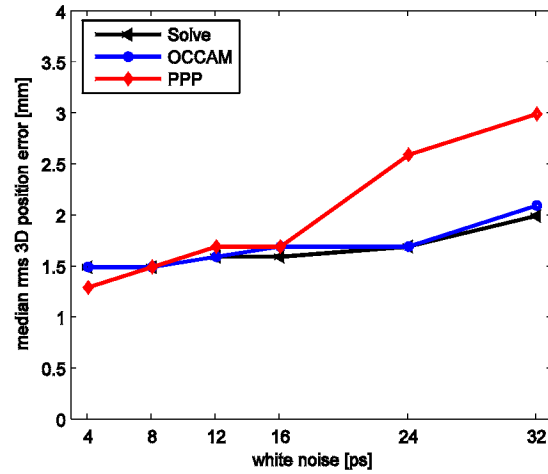

Figure 2-3. Median of the rms 3D position errors versus delay precision.

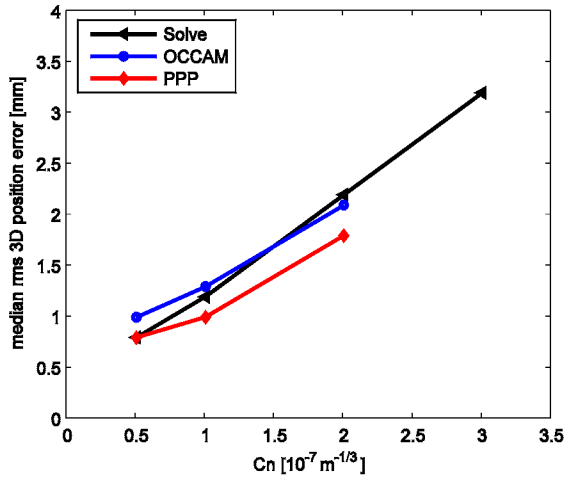

Figure 2-4. Median of the rms 3D position errors versus structure constant C_n of wet atmosphere.

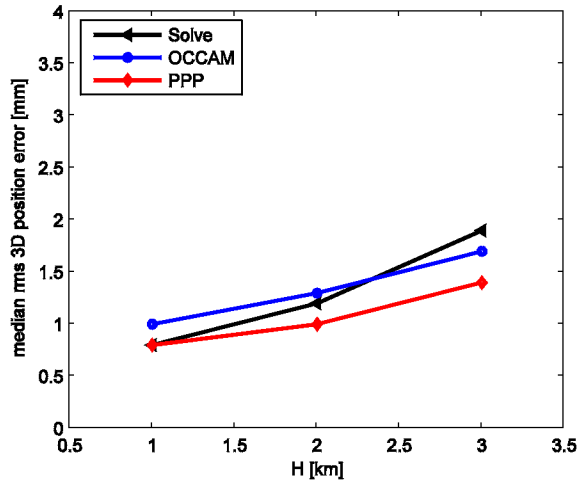

Figure 2-5. Median of the rms 3D position errors versus effective height H of wet atmosphere.

- In Figure 2-2 it is apparent that, with the VLBI2010 operating modes, geodetic performance is only marginally improved for clock systems that perform better than about $1 \cdot 10^{-14}$ @ 50 min. The performance measured currently for H-masers and their associated clock distribution systems is typically better than that.
- From Figure 2-3 it can be seen that performance is only slightly dependent on delay measurement noise. The anomalous behavior of the PPP solutions above 16 ps is not at present understood.
- In Figures 2-2 to 2-5, the comparatively strong dependence on C_n indicates that, even with the high delay measurement precision, short source-switching intervals, and globally distributed networks of VLBI2010, the atmosphere remains the dominant random error source for geodetic VLBI.

- Performance is nearly insensitive to wind speed and the plot is not included.

2.6 Network Size

In the WG3 final report larger and better-distributed global networks were recommended as a means of improving VLBI performance for both Earth orientation parameters (EOP) and the scale of the terrestrial reference frame. To test this, uniform sky schedules with 45-second switching interval were generated for the 16-, 24-, and 32-site networks developed for the Monte Carlo simulations (Section 2.2; [Niell, 2007](#)). For generating the input atmosphere delays, the turbulence parameters were set to $Cn = 2.4 \cdot 10^{-7} \text{ m}^{-1/3}$, $H = 1 \text{ km}$, and $\vec{v} = 8 \text{ m/s}$ towards east for all stations.

In Figure 2-6, rms EOP (X-pole, Y-pole, UT1) errors determined by both *OCCAM* and *Solve* are plotted against network size. In Figure 2-7, rms scale errors determined by *OCCAM* are plotted relative to network size. The improvement for the EOP precision and for scale is approximately 30% as the number of stations increases from 16 to 32.

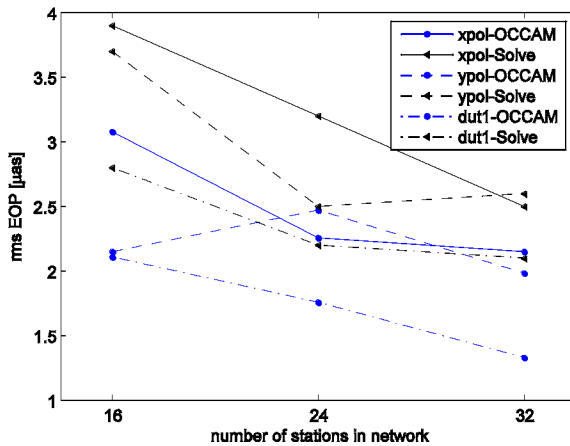

Figure 2-6. rms EOP errors derived from uniform sky schedules with 45-second switching interval and for 16, 24, and 32 stations. Results are plotted for both *OCCAM* and *Solve*.

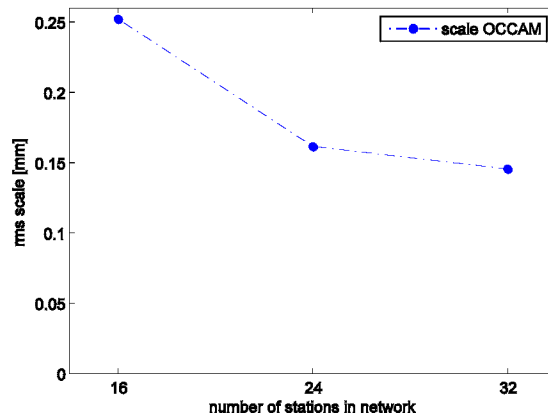

Figure 2-7. rms scale errors of the network (multiplied by the Earth radius) from uniform sky schedules with 45-second switching interval for 16, 24, and 32 stations. Results are for *OCCAM* Kalman Filter.

2.7 Validation of the Monte Carlo Simulators

To validate the Monte Carlo simulators, baseline repeatabilities for a 24-hour CONT05 schedule were determined using the simulators and compared to the baseline repeatabilities obtained for the 15 days of actual CONT05 data. For the simulators the clock ASD was set to $1 \cdot 10^{-14}$ @ 50 minutes, the formal delay errors for each scan were set to those reported for the actual CONT05 observations, and the atmosphere parameters, Cn , H , and \vec{v} , were set to the station-specific values listed in Appendix A. Since real atmosphere conditions can vary considerably from day to day and the atmosphere parameters for the simulators are based on a simple non-varying latitude dependent model, it was expected that the repeatabilities of the real and simulated data would be close in magnitude and show similar trends but would not be exactly the same.

Figures 2-8 and 2-9 show the actual and simulated CONT05 baseline length repeatabilities derived with the *OCCAM* Kalman filter and *Solve*, respectively. In the case of *OCCAM* the real and simulated repeatabilities are quite close, while for *Solve* the simulated repeatability is somewhat better than that of the real data. The reason for this discrepancy is not fully understood. Based on these results, performance predicted by the simulators is not expected to be optimistic by more than about 30%. Work continues on improving the atmosphere models.

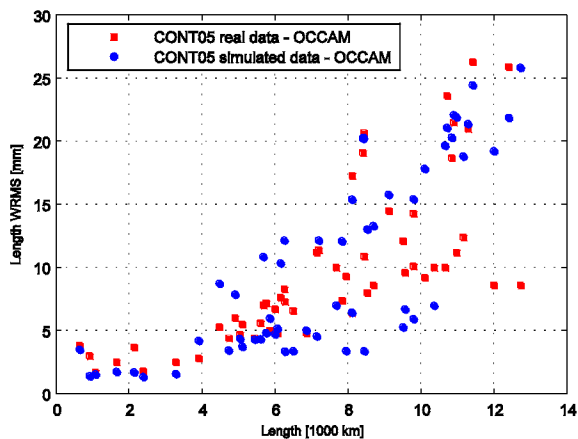

Figure 2-8. *OCCAM* Kalman filter baseline length repeatabilities of the actual CONT05 sessions (red squares) and the simulated sessions (blue circles).

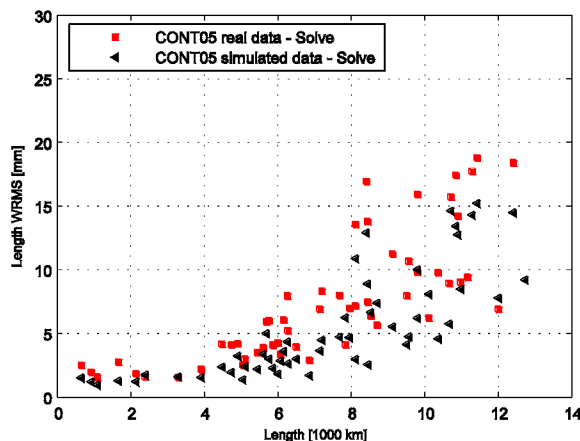

Figure 2-9. *Solve* baseline length repeatabilities of the actual CONT05 sessions (red squares) and the simulated sessions (black triangles).

2.8 Other Considerations

It is clear from Figure 2-1 that decreasing the source-switching interval is an effective means for improving geodetic VLBI performance. However, once short source-switching intervals have been implemented, it is interesting to ask what more can be done to reduce the impact of random error sources on the products. In this regard, Figures 2-2 to 2-5 provide valuable guidance. The clear dependence of the position error on C_n (Figure 2-4) and, to a lesser extent, on H (Figure 2-5) indicates that the dominant random error source for VLBI2010 operating modes remains the atmosphere. It is important that efforts to improve atmosphere modeling continue. Examples include the further development of water vapor radiometers (WVRs) ([Jacobs et al., 2006a](#); [Bar-Sever et al., 2007](#)); the use of numerical weather models to constrain atmosphere mapping functions, a priori, gradients, and correlations ([Böhm et al., 2006](#); [Eresmaa et al., 2008](#); [Hobiger et al., 2008a](#); [Hobiger et al., 2008b](#)); and the investigation of more novel approaches, such as tomography with an array of GNSS antennas, to improve knowledge of atmosphere anisotropy and temporal variability.

It is also useful to consider the implications of Figures 2-2 and 2-3 for clock performance and delay measurement precision. In the IVS WG3 final report ([Niell et al., 2006](#)), a clock ASD of $1 \cdot 10^{-16}$ @ 50 minutes and delay measurement precision of 4 ps were recommended. However, the lack of significant dependence of position error on clock performance and delay measurement error indicates that these recommendations may have been unduly stringent. Nevertheless, a compelling reason remains for improving clock stability and delay measurement error. In order to continue the reduction of errors from the atmosphere and from various systematic error sources (Section 3) the effect of different modeling approaches must be visible in the post-fit residuals and in the

repeatability of output products. This visibility is increased when the unmodeled clock error and delay measurement error are reduced.

Since the VLBI2010 system is intended to operate optimally for decades into the future, the clock system and delay measurement process should be designed to keep pace with the anticipated improvements in atmosphere and systematic error modeling so as not to be the limiting factors on product accuracy. It is therefore recommended that clock distribution systems at sites be improved, that developments in clock technology be monitored, and that an effort be made to improve delay precision significantly below today's levels (Section 3.3).

3 System Considerations

In the WG3 final report (Niell et al., 2006), several strategies were proposed to approach the 1-mm VLBI2010 position accuracy target. Of these, four have direct repercussions for VLBI2010 system parameters, namely:

- reduce the average source-switching interval,
- reduce the random component of the delay error (e.g., variation in the rates of the clocks, delay measurement noise, and delay due to the atmosphere),
- reduce systematic errors (e.g., instrumental drifts, antenna deformations, and source structure errors),
- reduce susceptibility to radio frequency interference (RFI).

Detailed studies of the first two strategies were carried out using the Monte Carlo simulators and are summarized in Sections 2.3 and 2.5, respectively, with further discussion in Section 2.8.

In this section the implications for VLBI2010 system parameters of the above WG3 strategies and the associated Monte Carlo studies are presented. The system-related issues that are considered are sensitivity, antenna slew rate, delay measurement error, RFI, frequency requirements, and antenna deformation. Source structure corrections are also covered in this section.

3.1 Sensitivity

Sensitivity is a measure of the weakest radio source that can be usefully observed by a given system. In radio interferometry, it can be expressed as

$$S_{weakest} = \frac{2k \cdot SNR_{min}}{\eta} \cdot \sqrt{\frac{T_{sys_1} \cdot T_{sys_2}}{A_{eff_1} \cdot A_{eff_2}} \cdot \frac{1}{BT}}, \quad (3-1)$$

where $S_{weakest}$ is the flux density of the weakest usable radio source, k is Boltzmann's constant, SNR_{min} is the minimum usable signal-to-noise ratio (SNR) per band, η is the VLBI processing factor (typically 0.5–1.0), T_{sys_1} and T_{sys_2} are the system temperatures at the two ends of the baseline, A_{eff_1} and A_{eff_2} are the effective collecting areas of the antennas, B is the sample rate per band, and T is the integration time.

For VLBI2010, competing requirements for short source-switching intervals, for detection of an adequate number of suitable sources, and for moderate overall system cost combine to constrain the possible values for VLBI2010 antenna diameter and data acquisition rate.

It is clear from Figure 2-1 that the source-switching interval must be significantly less than 60 s to approach the VLBI2010 1-mm position accuracy target. The implications are twofold: the antenna

must be able to slew quickly between sources, and the on-source period must be short, say ~ 5 s. Unfortunately, these two requirements are at odds with each other: high slew rates are easier to achieve with a smaller antenna, whereas larger antennas are more sensitive and can yield a given SNR in a shorter time on source.

As a practical matter, the choice of antenna size for VLBI2010 was driven by proposals for the NASA Deep Space Network (DSN) array and the Square Kilometre Array (SKA) to build thousands of 12-m antennas. The prospect that a low-cost, robust, 12-m antenna with good efficiency ($\sim 50\%$) and low system temperature (~ 50 K) would be developed for these projects made this size of antenna attractive for VLBI2010. The smaller size of a 12-m compared with the more typical 20-m size of today's IVS antennas should also lessen the difficulties in achieving increased slew rates. However, the question remains whether the smaller antenna can achieve the minimum SNR of 10 per 1-GHz-wide band that is required to securely resolve the broadband delay (Section 3.3) in the ~ 5 s allotted on each source. Answering this question requires knowledge of source flux densities and of realistic bit rates anticipated for the start of VLBI2010 operations.

Regarding source strength, catalogs of sources with little structure have recently been developed for geodetic applications. In the list of 230 sources produced by Leonid Petrov (cf. Section 2.2), the 185 strongest sources all have correlated flux densities above 250 mJy at both S-band and X-band, even for Earth diameter baselines, and the ninety strongest sources have correlated flux densities above 400 mJy.

Regarding bit rate, the state-of-the-art for sustained data acquisition bit rate is currently around 2 Gbps (1 Gbps = 10^9 bits/second), with 4-Gbps systems in an advanced stage of development. Since operations with a significant number of VLBI2010 antennas are not likely to begin for several years, and commercial disc and network capabilities continue to advance rapidly, a sustained bit rate of 8 Gbps is anticipated for the start of VLBI2010 operations. In addition, to further shorten the on-source period, a "burst mode" data acquisition capability is proposed for VLBI2010 in which data are acquired into RAM at a rate four times higher (burst factor of 4) than the record rate, or 32 Gbps. Writing to disk will then continue while the antenna is slewing to the next source.

Under these conditions the average integration time needed to achieve the minimum SNR for the 185 sources in the Petrov list with flux densities above 250 mJy is ~ 4.5 s ([Petrachenko, 2008c](#)), which corresponds to an average data volume of ~ 18 Gbytes per scan at each station. Note that an additional 13.5 s are required on average during slewing to complete the write to disk at 8 Gbps. For the 90 sources above 400 mJy the average integration time is 2.5 s, the average data volume per scan is 10 Gbytes, and an additional 7.5 s are required during slewing to finish writing to disk.

In summary, under the assumptions of an 8 Gbps record rate and a burst factor of 4, antennas with 12 m diameter, 50% aperture efficiency, and 50 K system temperature can detect about 185 geodetic-quality radio sources with adequate SNR in the short time span of ~ 5 s allowed by the necessity of switching rapidly between sources. This defines the minimum diameter of the antennas. However, larger antennas are useful both for maintaining the celestial reference frame (CRF) at lower flux densities and for providing extra SNR margin in the presence of RFI and other hard-to-control external factors.

3.2 Antenna Slew Rate

The IVS WG3 final report suggests a major increase in observation density (or, equivalently, a major decrease in source-switching interval) as a strategy for increasing VLBI position accuracy. The simulation results displayed in Figure 2-1 indicate that this strategy is in fact very effective for increasing position accuracy and consequently has been identified as an essential element of

VLBI2010. In this section the implication of decreasing source-switching intervals on antenna slew rates and accelerations is considered.

Analysis for this section was carried out in two steps ([Petrachenko et al., 2008](#); [Petrachenko, 2008b](#)).

- Optimized uniform sky schedules and the Monte Carlo simulators were used to develop a relationship between the median of the rms 3D position errors and the source-switching interval.
- The same schedules were then analyzed to produce families of antenna slew rates and accelerations that achieve a specified average source-switching interval.

To constrain the range of possibilities, only two antenna mount types were considered. The first was a standard (STD) azimuth/elevation (az-el) mount with azimuth range -270° to $+270^\circ$ and elevation range 5° to 90° . The second was an over-the-top (OTT) az-el mount also with azimuth range -270° to $+270^\circ$ but with an elevation range of 5° to 175° . The WG3 final report also proposed the use of multiple antennas at a site to share the observing load and hence to reduce the effective source-switching interval. The case of a second antenna at a site was therefore considered.

To begin the study, four uniform sky schedules ([Petrachenko et al., 2008](#); [Petrachenko, 2008b](#)) were generated having regular source-switching intervals of 15, 30, 45, and 60 s. The results of the Monte Carlo runs are plotted in Figure 3-1.

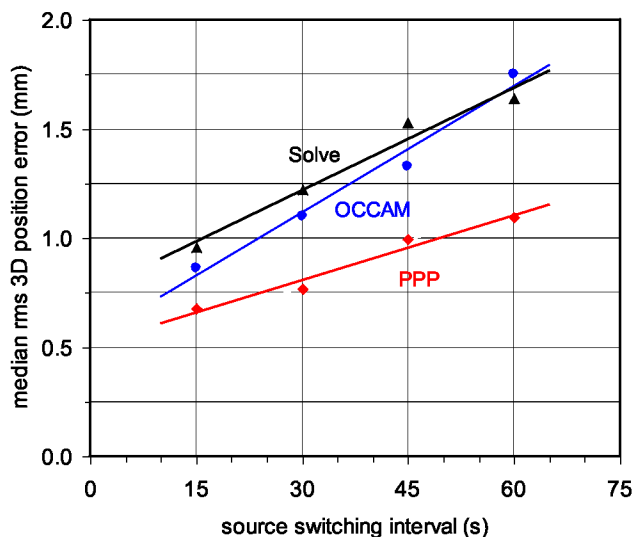

Figure 3-1. Median of the rms 3D position errors vs. source-switching interval for four uniform sky schedules that were optimized to reduce slew time.

Based on the *OCCAM* results in Figure 3-1, source-switching intervals were identified to achieve median 3D position errors of 1.0, 1.25, 1.50, and 1.75 mm. The schedules were then re-analyzed to determine all combinations of azimuth and elevation slew rates that achieve each of the above four source-switching intervals. This was done for a number of different slew accelerations. Plots of azimuth vs. elevation slew rate were then generated for the four performance levels, for both mount types, and for either one or two antennas per site. As an example, the case of 1-mm performance for a pair of STD az-el antennas is displayed in Figure 3-2.

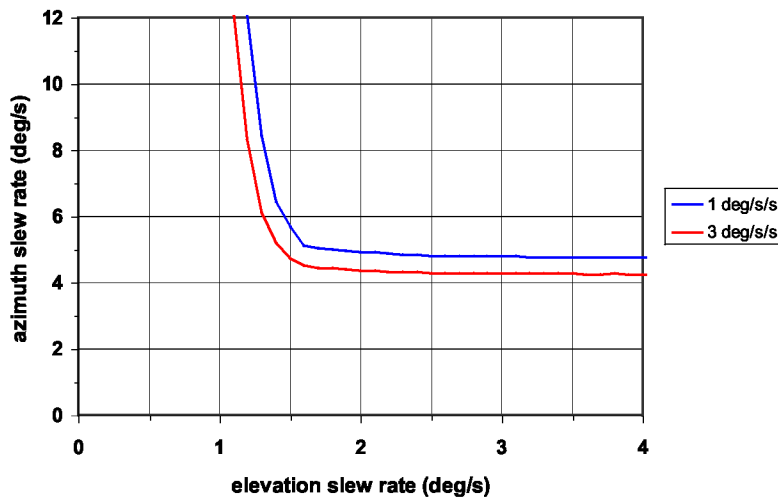

Figure 3-2. Azimuth and elevation slew rates to achieve 1-mm median of the rms 3D position errors for a pair of STD az-el antennas accelerating at 1 or 3 deg/s/s in both axes.

Figure 3-3 summarizes the results for one or two antennas at a site of both types. To generate this figure, it was assumed, based on Figure 3-2 and similar figures, that the optimum ratio between the azimuth slew rate and the elevation slew rate is about 3.5:1 for STD mounts, while for the OTT mounts the optimum ratio is about 1:1. Using these ratios, Figure 3-3 gives information about both azimuth and elevation slew rates. Slew accelerations no greater than 1 deg/s/s are required, except for a single antenna at 1-mm position error, in which case an acceleration of 3 deg/s/s is required for the STD mount and 2 deg/s/s for the OTT mount.

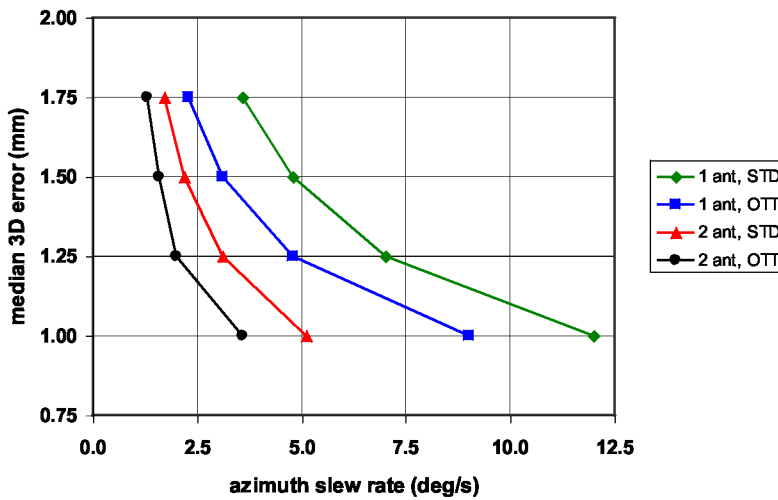

Figure 3-3. Median of the rms 3D position errors vs. azimuth slew rate for either one or two antennas at a site and for both the STD and OTT mount types.

While it is clear from this study that a single STD antenna with 12 deg/s azimuth slew rate will achieve 1-mm position error, other options can be considered such as a pair of antennas, each with significantly lower azimuth slew rate than 12°/s. For example, from Figure 3-3, a single STD antenna with 5°/s azimuth slew rate can be expected to achieve 1.5 mm 3D position accuracy. This is almost all of the improvement from current levels of performance to the 1 mm VLBI2010 target. At a later time, as the need increases or as funding becomes available, a second antenna could be

added at a site to complete the improvement to 1 mm. If this approach is taken, a location for the second antenna should be set aside from the beginning.

3.3 Delay Measurement Error and the Broadband Delay Concept

The WG3 final report concluded that a delay measurement precision of 4 ps is required to achieve the VLBI2010 1-mm position accuracy target. This is nearly an order of magnitude improvement over current performance and cannot be achieved with existing dual-band S/X group delay systems ([Petrachenko, 2006](#)).

Fortunately, the development of data acquisition systems for astronomy with more than 10 GHz of instantaneous frequency coverage ([DeBoer et al., 2004](#); [US SKA Consortium, 2004](#)) has opened up the possibility, for geodetic VLBI, of using multiple, widely spaced frequency bands to resolve the very precise radio frequency (RF) phase delay with only modest SNR per band. This has been demonstrated theoretically ([Petrachenko, 2008a](#)) and allows the contemplation of systems that have excellent delay precision without the need for the high sensitivity that forces the use of large (and hence typically slowly moving) antennas. For an ideal operating environment with no RFI or source structure, it has been shown that a 4-band system (1 GHz per band) with RF frequency range 2–14 GHz can reliably resolve phase delay for SNRs as low as 10 per band and achieve delay precision of ~2 ps.

The delay derived using multiple widely spaced bands to resolve the phase delay has come to be known as the “broadband delay”. Since this approach is new, a proof-of-concept project has been initiated by NASA to test the idea experimentally and to gain experience with practical forerunners of VLBI2010 subsystems (cf. Section 5).

The implications of using the broadband delay for the VLBI2010 signal path are profound. They include the use of linearly polarized broadband feeds, broadband low-noise amplifiers (LNAs), fiber optic transmission of the RF signals from the antenna focus to the control room, an increase in the number of RF bands from two to four, and flexible frequency selection for each of the four RF bands (Section 4.1).

Known risks to implementing the broadband delay technique are related to radio source structure and RFI. It has been shown theoretically ([Niell, 2006b](#); [Niell, 2006c](#); [Rogers, 2006](#)) that the impact of even moderate source structure on interferometer output degrades the ability to connect phase between RF bands and ultimately to resolve the RF phase. RFI, on the other hand, restricts the use of regions of the 2–14 GHz broadband spectrum and hence limits the optimal definition of frequency sequences. Approaches for handling both risks are considered in more detail in Sections 3.7 and 3.4, respectively.

3.4 Radio Frequency Interference (RFI)

RFI is the man-made radio transmissions inadvertently added to the desired signal of interest from the target VLBI radio source. It can originate from fixed, mobile, marine, aeronautical, or space-based transmitters and for purposes ranging from commercial broadcast to scientific and amateur. In fact, the entire broadband VLBI2010 frequency range from 2 to 14 GHz is allocated for a myriad of applications through international, national, and regional agreements, with only a tiny portion set aside for radio astronomy. The broadband VLBI2010 receiving system must function in this somewhat hostile RFI environment, and it is expected that conditions will degrade over time through greater demand for the spectrum.

Fortunately, VLBI systems are comparatively robust against RFI. The large parabolic reflectors required to enhance the weak VLBI signals are also highly directional so that transmissions

arriving from outside the main beam of the antenna are strongly attenuated relative to in-beam signals. In addition, due to the wide separation of VLBI antennas, the same interfering signal is rarely seen at both ends of a baseline and so do not correlate. Even when the same signal can be seen at both ends of the baseline (e.g., from geostationary satellites), it appears in the cross-correlation at a different delay and fringe rate from those of the signal of interest and so does not affect the measured interferometric visibility.

For the case of moderate RFI arising from off-axis signals entering the antenna sidelobes, the primary impact is an increase in system temperature. In this case, the effect is isolated to the actual frequencies of the RFI. In the event that phase biases exist in the spectral region of the RFI, intermittent RFI will effectively modulate the biases and cause systematic variations in the measured delay ([Shaffer, 2000](#)).

For RFI that is strong enough to saturate the receiving system, the impact is much worse. At times when the RFI causes clipping, the VLBI signal disappears entirely, and the system sensitivity plummets across the full band, not just in the spectral region of the RFI. If the RFI is strong enough to cause clipping most of the time, a single narrowband interferer can effectively destroy the entire band. This situation must be avoided at all costs. To mitigate this problem, the dynamic range of the VLBI2010 receiving system from LNA to sampler needs to be high. In cases where the RFI is still too strong, band rejection filters need to be used prior to the point in the system where saturation occurs.

The implementation of a broadband receiving system for VLBI2010 introduces both advantages and disadvantages. On the one hand, it provides the freedom to shift selected bands to avoid RFI. On the other hand, it means that the full frequency range from 2 to 14 GHz must be received, making the system vulnerable to saturation if a large interferer is found anywhere in the range.

Efforts have begun to better understand the RFI environment. The NASA proof-of-concept project, with antennas outside large metropolitan areas (Boston and Washington, D.C.), provides a valuable test bed for evaluating the susceptibility of VLBI2010 systems to RFI. It is already clear that frequency selectivity below 2 GHz is required to avoid saturation from out-of-band TV signals.

In addition, searches of frequency allocation tables provide information about the RFI environment. Frequency ranges allocated for satellite TV broadcast (e.g., 3.7–4.2 GHz and 10.7–12.7 GHz), among others, have been identified as potential problems, but a more detailed analysis of the impact on the full VLBI2010 system is required to better assess the risk.

3.5 Frequencies

Throughout this document a number of VLBI2010 functions have been discussed that require access to specific regions of the radio spectrum. In this section all the frequency ranges are collected together and their purpose and limitations are considered ([Petrachenko, 2008e](#)). Due to practical considerations related to the antenna feed, it is unlikely that all can be implemented simultaneously.

- *Broadband (2–14 GHz)*. This is the most important frequency range for VLBI2010 since it enables the use of the broadband delay to improve delay precision by roughly an order of magnitude. It is likely that RFI will challenge the lower limit of this range and that, at least in the short term, technology will constrain the upper limit. For optimal VLBI2010 performance, illumination of the antenna by the feed should be independent of frequency and isotropic about the antenna axis, and the physical location of the feed phase center should also be independent of frequency. Broadband feeds are discussed further in Section 4.5.

- *S/X band (2.3 and 8.5 GHz)*. Current geodetic VLBI systems use a dual-band receiver with S band in the 2.2–2.4 GHz range and X band in the 8.2–8.95 GHz range. Although it is expected that existing antennas will eventually upgrade their feed/receiver systems to VLBI2010 specifications, interoperability with existing systems is necessary during the period of transition to VLBI2010 operations. In addition, since source positions are frequency dependent, there is a strong requirement to continue access to S and X bands to maintain a connection with the current International Celestial Reference Frame (ICRF).
- *Water vapor band (18–26 GHz)*. The primary error source for geodetic VLBI is the wet atmosphere. One option for reducing its contribution is to measure the wet delay directly using a WVR ([Elgered et al., 1991](#); Emaradson et al., 1999). Such instruments have been under development for many years, but, to date, none has shown convincing improvement for geodetic results, although they are valuable for meteorological studies. The addition of a coaxial 18–26 GHz feed and radiometer to the VLBI2010 receiving system would enable line-of-sight WVR measurements. This configuration would eliminate the low elevation and axis offset problems typical of current WVRs, but two current problems would remain: WVRs are unusable in the presence of rain, and the conversion from WVR brightness temperature to atmosphere delay needs detailed knowledge of the water vapor and temperature profiles along the line of sight.
- *Ka band (32 GHz)*. Due to RFI problems at S band, the NASA DSN is making a transition from S/X spacecraft tracking to X/Ka (8/32 GHz). To support this transition, an X/Ka celestial reference frame is being developed at JPL ([Jacobs et al., 2006b](#); [Jacobs and Sovers, 2008](#)). Because sources are generally more compact at Ka band, the X/Ka CRF is expected to be considerably more stable than the S/X. However, these benefits are somewhat offset by the fact that antenna and receiver design is more difficult at Ka band, sources are weaker, and atmospheric transparency and delay stability can degrade to the point that observations are impossible under some atmospheric conditions. Also, in many cases, reflectors of existing geodetic VLBI antennas have low efficiency at Ka band.
- *GNSS (1.1–1.6 GHz)*. There are two motivations for observing GNSS satellites with a VLBI antenna. One is to improve GNSS orbits by tracking satellites directly in the inertial frame defined by the ICRF. These observations could also serve as an additional method of inter-comparing VLBI and GNSS. The second motivation is to make differential measurements between the VLBI antenna and a small local directional GNSS antenna to establish gravitational and thermal models for the VLBI antenna and to establish and monitor intra-site ties.

3.6 Antenna Deformations

Antenna structures undergo both thermal and gravitational deformations. Both bias the effective position of the antenna. It is clear that the development of a stable, externally accessible set of reference marks is necessary for decoupling geophysically interesting site motions from intrinsic antenna deformations, for enabling comparisons and combinations of VLBI with other techniques, and for providing more general access to the VLBI frame.

- *Gravitational deformations*. Gravitational sag of the antenna reflector and feed support structure results in elevation-dependent delay variation and hence biases of the height estimates. Although measurements and calculations to determine gravitationally induced height bias continue to be refined (e.g., [Bolli et al., 2006](#)), they are complex, labor-intensive, and prone to error. One simple alternative is to construct antennas that are stiff with respect to

gravitational deformation. This is easier to achieve for smaller antennas, which bodes well for the 12-m antennas proposed for VLBI2010.

- *Thermal deformations.* Thermal deformations can be classified as deformation of the antenna reflector (and feed support structure) and of the antenna tower. In the former case, the delay dependence is generally considered to be benign since it tends to be clock-like and hence can be removed as part of the clock estimates. However, in the case of the antenna tower, thermal expansion and contraction cause the VLBI reference point to move up and down (and to a smaller extent side to side) and hence bias the station position estimate. For larger antennas, annual signatures can be in excess of 10 mm peak-to-peak and can clearly be seen in current data records. Three main approaches have been developed to measure or model the thermal deformations: the deformation is modeled based on antenna materials and simple physical models; the vertical deformation between a fixed point on the ground and the antenna intersection of axes is monitored using an invar wire; and the deformation is modeled using more complex analysis involving multiple temperature sensors and comparisons with invar wires. Another option is to build antennas out of materials with low coefficient of thermal expansion, such as composites based on Kevlar or carbon fiber. The smaller size of the VLBI2010 antenna reduces the amplitude of thermally induced deformations.

A final promising approach that has been suggested (Koyama, 2004; [Ichikawa et al., 2008](#)) is connected-element interferometry between a small (~2 m), structurally well-understood antenna and the primary VLBI2010 antenna. The purpose is to measure the baseline between the small stable antenna and the VLBI2010 antenna repeatedly and thereby to build and maintain thermal and gravitational models of the primary antenna. In a sense, this transfers the effective VLBI reference point to the intersection of axes of the small reference antenna. Due to its small size, it is expected that the reference antenna can more easily and accurately be connected to an external survey point. If the small antenna is also sensitive at GNSS frequencies as discussed in Section 3.5, it is conceivable that the intersection of axes of the small antenna could be connected directly to the effective IGS reference point. The simplicity, operational ease, and potential accuracy of this approach make it an attractive option.

3.7 Source Structure Corrections

The ideal radio source for reference frame definition is a point source with no apparent variation in position. Real sources, on the other hand, typically have structure that varies with both time and frequency. It is not uncommon that the structure of ICRF sources introduces tens of ps of group delay. These delay biases pose a risk both to resolving the broadband delay (Sections 3.3 and 7) and to achieving the VLBI2010 goal of 1-mm position accuracy.

In current geodetic VLBI practice, source structure effects have been mitigated by selecting sources that are known to have minimal structure. Although improved source lists have recently been compiled, many sources in the new catalogs still have enough structure to impair the ability to successfully resolve the broadband delay ([Niell, 2006b](#); [Niell, 2006c](#); [Rogers, 2006](#)).

Another strategy for dealing with source structure is to determine the structure from the geodetic data and correct for it. This has not been done routinely because current operational geodetic/astrometric schedules do not include enough observations of each source to create high quality images. The anticipated VLBI2010 operating modes resulting from larger networks, rapidly slewing antennas, higher data rates, and broadband operation will enable a significant increase in the number of observations per session, thus opening up the practical possibility of routinely generating source structure corrections from each operational geodetic/astrometric observing session.

Generating source structure corrections involves four steps:

- create an image of the source for each band of the VLBI2010 broadband system,
- use the images to generate source structure corrections at each observed u-v point,
- align the images in each of the bands relative to the highest frequency band,
- select a physical point in the highest frequency image to serve as the position reference for the source.

These steps are described in more detail in the Sections 3.7.1–3.7.4, including a discussion of the Monte Carlo simulations that have been performed to study the effectiveness of carrying out source structure corrections for the VLBI2010 systems.

3.7.1 Imaging Capabilities of the VLBI2010 System

In order to study the imaging capabilities of the VLBI2010 system, a processing pipeline that simulates the generation of VLBI images from VLBI2010 test schedules has been developed. Simulated VLBI images have been successfully produced for various schedules with different network configurations, numbers of observations per day, and observing strategies. Details concerning the pipeline and the initial results obtained in the case of high SNR sources are presented in [Collioud and Charlot \(2008\)](#). Additional simulations have been carried out for weaker sources (40 mJy) assuming a typical noise level equivalent to an SNR of 20. Results are presented in Figure 3-4.

The simulations demonstrate that the standard hypothetical 16-station network of the VLBI2010 system is in general well suited to producing high-quality images. However, this network fails to recover extended structures for far south sources due to the lack of short baselines in the southern hemisphere.

Tests were therefore carried out to determine whether adding two stations at carefully selected locations could help fill the central hole in the u-v plane and mitigate the southern hemisphere image reconstruction problem related to the lack of short baselines with just 16 stations. As shown in Figure 3-4, an 18-station network with two additional stations in the southern hemisphere clearly improves the recovery of extended structures, giving simulated images at southern declinations that have a quality comparable to northern sources.

3.7.2 Structure Corrections Based on VLBI2010 Images

The simulated VLBI2010 images may also be used to generate structure correction maps. These represent the effects of source structure on the broadband delay, or S/X synthesis delay, as a function of interferometer resolution. The structure correction maps also form the basis for the calculation of structure indices which characterize the astrometric suitability of the sources ([Fey and Charlot, 1997](#); [Fey and Charlot, 2000](#)).

Work is planned to assess the accuracy of the structural corrections derived from VLBI2010 images. For this purpose a sample of 100 similar VLBI2010 images has been produced using the same input source model but considering different errors in the simulated visibilities, generated using a Monte Carlo method. In a second step, the structure correction maps corresponding to these images will be derived and differenced with the theoretical structure correction map calculated from the “true” source model. From statistics of these differences, the accuracy of the corrections can be estimated. Such calculations will be repeated for different declinations and different source models. As noted above, inaccuracies in pinpointing the spatially invariant physical feature of the

source should also be considered for a complete assessment of the error budget. Ultimately, these calculations should help determine whether the corrections are compatible with the 1-mm accuracy goal.

3.7.3 Relative Alignment of the Images in Different Bands

Since the maps generated in the first step lack information about their absolute positions, the images in the different bands need to be aligned relative to each other in order to properly combine the data. Fortunately, the group and phase delays contain sufficient information to simultaneously resolve phase ambiguities and to align the map centers (Petračenko and Bérubé, 2007). The precision with which this can be done is dependent on the frequencies of the bands and the number of observations of the source. Petračenko and Bérubé (2007) conclude that relative map offsets can be reliably and accurately determined directly from VLBI2010-like data at an SNR of about 7 per band. This limit has been found under the assumption that the source is covered by at least 200 well-spaced scans within a 24-hour session. Using a somewhat different approach, Hobiger et al. (2008c) report even better performance.

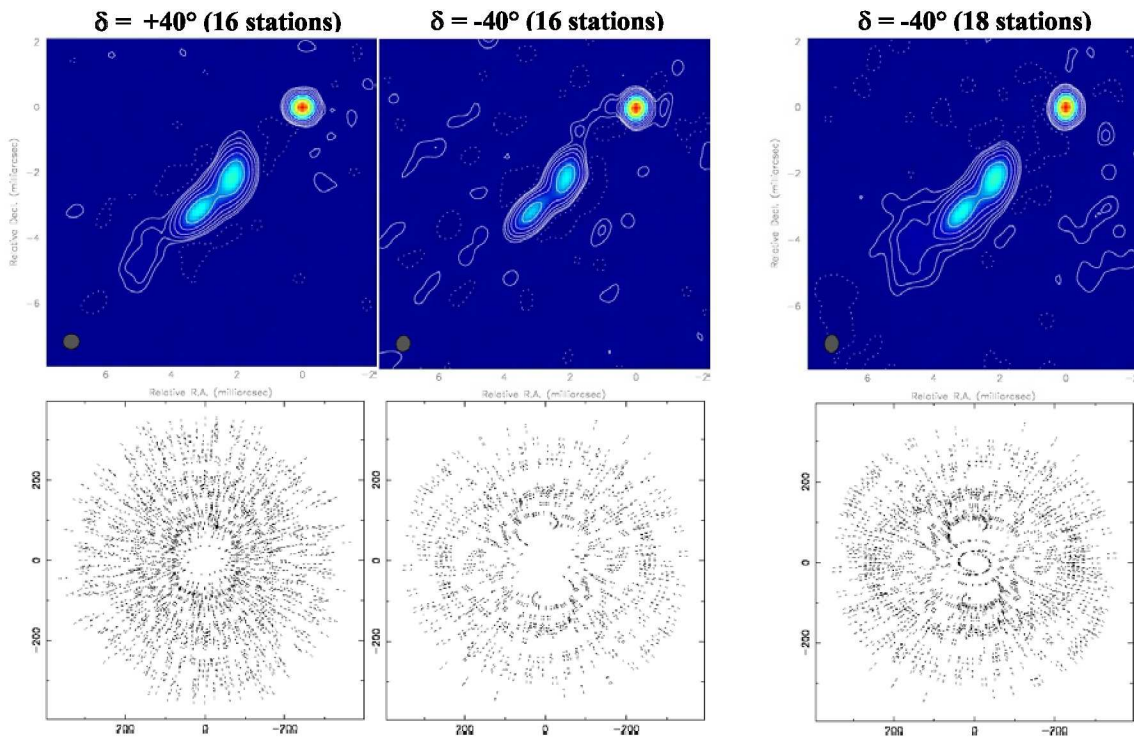
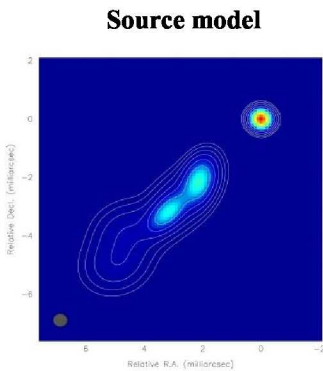

Figure 3-4:

Upper panels: Reconstructed VLBI images at declinations $+40^\circ$ and -40° for a typical VLBI2010 uniform schedule (60 s source-switching interval). The first contour corresponds to 0.05 mJy/beam (0.5% of the peak brightness) with successive contours increasing by a factor of two. The image on the right-hand side is that obtained when supplementing the usual 16-station network with two new stations. Middle panels: u-v planes corresponding to the images immediately above them (in units of $10^6 \lambda$). Lower left hand panel: The original source model convolved with a beam of 0.5 mas x 0.5 mas. The images in the upper panel can be compared to this source model. The total flux density is 40 mJy.



3.7.4 Identifying a Position Reference for the Source

A position reference point must be identified for each source. In the absence of structure corrections, this point is naturally placed at the centroid of the brightness distribution. Unfortunately, the centroid is typically not fixed over time or with observing frequency. Much better for geodesy/astrometry is to associate some feature of the map with a positionally invariant physical feature of the source, typically the black hole at its core. The problem is that the majority of radio emission from the source is generated by dynamic jets emanating from the core, but not the core itself. Some success has been achieved by modeling the core-jet nature of the source as a point plus elliptical component ([Fomalont, 2006](#)).

4 System Description

Presented here is an overview of the current status of the V2C recommendations for the next generation system. Some recommendations, e.g., the antenna, are nearly complete, while others, e.g., the correlator, are at an early stage in their development. Not all major subsystems are discussed in detail, although all are at least mentioned here as part of the system overview. VLBI2010 recommendations for the network, station, and antenna are given in Sections 4.2–4.4. Some aspects of the feed, polarization processing, calibration, digital back end, and correlator subsystems are presented in Sections 4.5–4.10.

4.1 System Overview

Figure 4-1 is a block diagram of the VLBI2010 system. Its architecture, which differs significantly from that of existing geodetic VLBI systems, is driven by the needs for short source-switching intervals, improved delay measurement precision, smaller drifts of the electronics, and improved automation and operational efficiency. Of particular note is the change from a system with two fixed bands (S and X band) to a system with four bands, each of which can be placed anywhere in the 2–14 GHz range. The maximum VLBI2010 bit rate of 32 Gbps is based on the following assumptions: four bands, two polarizations, a Nyquist zone bandwidth of 1 GHz, 2 Gsample/s sample rate and 2 bits/sample. Technologically, many of the changes are enabled by continuing improvements in digital electronics. A suggested model for the VLBI2010 subsystem characteristics is summarized below.

- Antennas are relatively small (≥ 12 m), fast slewing, and capable of mostly unattended operation (Section 4.4).
- Feeds are cryogenically cooled with dual linear polarization and continuous frequency coverage from 2 to 14 GHz (Section 4.5).
- Both linear polarizations are acquired, and all four polarization products are processed at the correlator (Section 4.6).
- The front end receiver is comparatively simple and includes
 - broadband LNAs for the two polarizations,
 - noise and pulse calibration subsystems, which inject signals into the receiver to calibrate the complex system gain down to the digitizer (Sections 4.7 and 4.8).
- The broadband (2–14 GHz) RF signals are transmitted directly from the receiver to the control room on fiber optic cables. This minimizes the number of signal cables between the receiver and control room and allows downstream analog processing, such as frequency translation and filtering, to be done under better controlled environmental conditions.

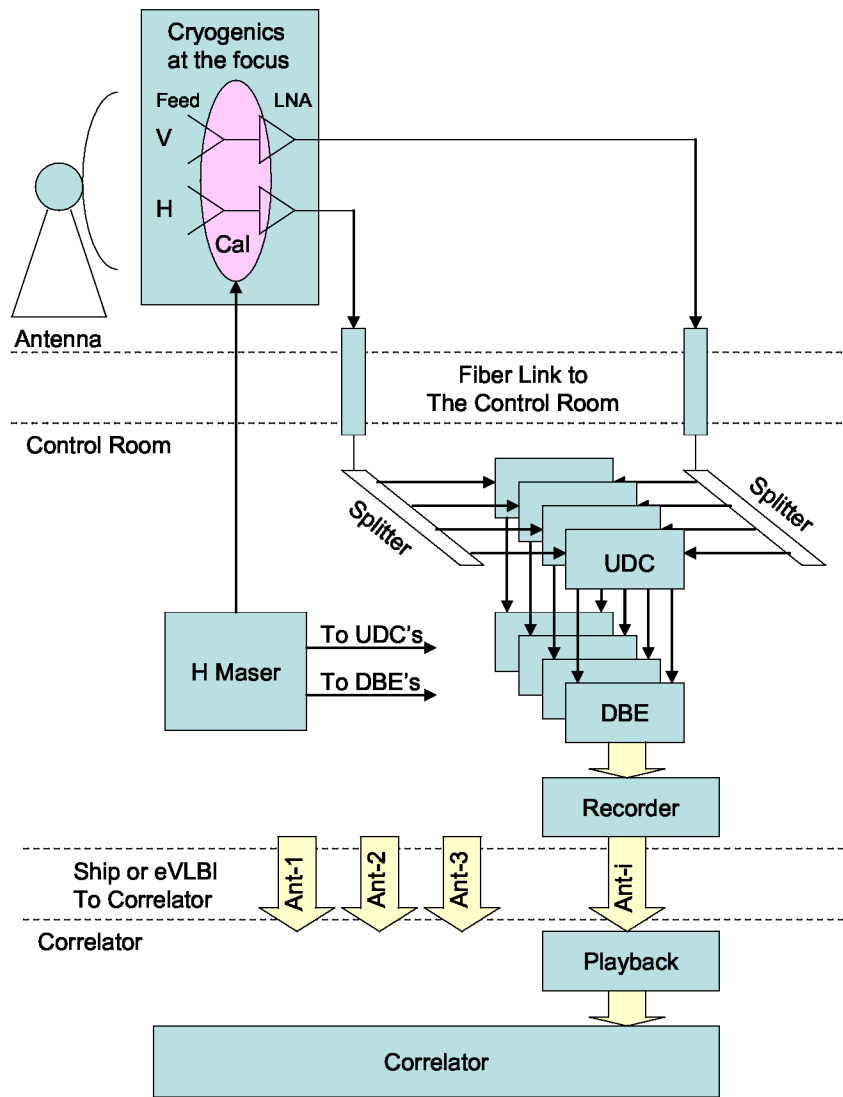

Figure 4-1. VLBI2010 block diagram.

- Four RF bands are processed, enabling the use of the broadband delay technique (Section 3.3).
- Each RF band is frequency-translated to the intermediate frequency (IF) range (0–3 GHz) in a flexible up-down converter (UDC). The translation is done in two mixing steps. The input is first shifted up in frequency with a programmable synthesizer to put the desired portion of the RF band in a predetermined, fixed frequency range. The signal then passes through a bandpass filter before being translated down to IF, where it can be digitized.
- The output of the UDC is sampled at 10 bits/sample and processed in the digital back end (DBE). Input signals initially pass through 1-GHz-wide anti-alias filters before sampling. Up to three Nyquist zones may be available. The sampled data are then processed in a field programmable gate array (FPGA), the primary functions of which are channelization, bit-truncation, and data quality analysis, including power level measurement and calibration signal detection (Section 4.9).

- A hydrogen maser provides the frequency and timing reference signals for the pulse calibration subsystem, the UDCs, and the DBEs.
- Data are stored, at least temporarily, on disk recorders.
- Recorded data are either shipped to the correlator on disk packs or, where possible, transmitted over optical fiber.
- Correlation is done in one or more software correlators (Section 4.10).

4.2 Network Recommendations

It is expected that increasing the number of VLBI stations and improving their global distribution will be beneficial for the three main product groups of the IVS: terrestrial reference frame (TRF), CRF, and EOP. The IVS WG3 final report recommends a VLBI2010 network of between 20 and 40 globally distributed stations, with the 20-station estimate based on roughly three sites per continent and the 40-station estimate based on a site spacing of approximately 2,000 km over all land masses.

For the TRF it is vital that the VLBI2010 scale be accurate and be transferred as effectively as possible to the International Terrestrial Reference Frame (ITRF). A robust transfer requires a large total number of VLBI sites co-located with the other techniques, GNSS, satellite laser ranging (SLR), and Doppler Orbitography and Radio-positioning Integrated by Satellite (DORIS) (along with improved site ties), while a more stable scale estimate itself requires more frequent observations with a larger network observing instantaneously. Although more frequent observations can be expected to improve results through averaging, dense time series of station positions will perhaps more importantly prove valuable for revealing, understanding, and eventually reducing systematic errors. While the primary emphasis in network design is on achieving a uniform global distribution of stations, the insensitivity of short baselines to EOP and to source structure errors makes regional site concentrations attractive as test beds for improving, for instance, atmosphere modeling and site ties.

For CRF a larger better-distributed global network improves u-v coverage, which is a prerequisite for generating higher quality images of radio sources, and also yields more uniform CRF quality between the northern and southern celestial hemispheres. In addition, a more uniform north-south distribution of stations leads to reduced coupling between global troposphere gradients and estimates of station latitude and source declination. Regional concentrations of stations will be needed to provide the short baselines for imaging the larger scale structure of the CRF sources. A larger global network, when coupled with the increased number of observations anticipated for VLBI2010, also opens the possibility of generating source structure corrections directly from the VLBI2010 data (Section 3.7); these corrections will benefit all of the IVS data products. Although not necessarily required on a daily basis, a subset of larger antennas will allow detection of weaker CRF sources.

For EOP it is necessary that the VLBI2010 estimates be strongly coupled to the ITRF. Experience has shown that EOP estimates from current VLBI networks show biases relative to each other and that those biases change with time. The systematic impact of any single station on VLBI EOP determinations can be expected to become smaller as the network size increases, making a larger network more robust against changes in network composition. At least a subset of the antennas needs high speed data links to the correlator to allow near-real-time (< 24 hours) EOP delivery.

The VLBI2010 network also needs to be considered in the context of other space geodetic techniques. Due to the small numbers of VLBI and SLR sites, established and planned SLR sites should be considered as potential locations for new VLBI2010 antennas. This anticipates the demand for all-technique sites for GGOS 2020 ([GGOS, 2009](#)).

All V2C simulations have shown that a global 16-station network observing simultaneously can achieve the performance goals of VLBI2010. However, based on the considerations given above and due to time necessary for maintenance and repair, the following recommendations are made for the minimum VLBI2010 network.

- Have at least three regularly observing stations on each major tectonic plate, with more encouraged in regions where economics allow.
- Have at least eight regularly observing stations in the southern hemisphere.
- Have at least six regularly observing, globally distributed stations with high data rate connection to one or more correlators to enable near-real-time EOP delivery.
- Have at least eight larger (≥ 20 m) antennas (four per hemisphere) for CRF densification.
- Wherever possible, co-locate new VLBI2010 stations near existing or planned space geodesy observatories, with a priority to SLR sites.
- Have a capability to process continuous observations for at least 24 stations, with a long-term goal to increase the number to at least 32 stations.

4.3 Station Recommendations

In order to establish a high quality VLBI2010 station, criteria are required for site selection, for local surveys, and for instrumentation ([Malkin, 2008a](#)).

Once the general location of a site has been determined based on network considerations, it is recommended that the following criteria be applied for site selection.

- The site should be geologically stable, i.e. located on firm, stable material, preferably basement outcrop, with small groundwater fluctuations. In regions where this is impossible, particular attention should be given to the stability of the antenna foundation and a robust tie to a well-designed regional footprint should be developed.
- The site should be free of existing and forecastable obstructions above 5° for at least 95% of the horizon.
- The site should have a minimum of RFI from existing and forecastable local transmitters. Over the longer term, contacts with local regulators should be developed to ensure that the RFI environment does not degrade significantly.
- The site should be co-located with other space geodesy techniques (GNSS, SLR, DORIS, and gravimetry), preferably with long observational histories. For sites where other techniques may be introduced in the future, site criteria for those techniques should also be taken into account.
- The site should include space for a second VLBI2010 antenna if possible.
- The site should be near an existing or planned high-speed data link with a long-term goal of a data transmission rate of at least 4 Gbps. Where not possible, access to expedient shipping is required.

- The site should be connected to regional/national geodetic networks.
- The site should be developed in coordination with IVS, IAG/GGOS, and IAU directing bodies.
- The site should be secure and have access to power, transportation, and personnel.

Local geodetic networks are needed to monitor the stability of the VLBI reference point. The local network should consist of a station network and a regional footprint network. The accuracy of the surveys should be significantly better than 1 mm, and all survey data should be rigorously reduced to provide 3D geocentric coordinate differences in the ITRF system.

The station network should meet the following criteria:

- There should be at least three ground monuments around each VLBI antenna at a distance of 30–60 m (up to 100 m for large antennas).
- Visibility from these monuments to the other space geodetic techniques should be provided.
- The monument design should correspond to the local geological conditions and provide maximum stability over time.
- The local network should be surveyed at least as often as once every 2.5 years, in summer and winter seasons alternately. More frequent surveys, once every six months, should be performed during the first two years after installation of new instrumentation or monuments.
- Measurements of the temperature-adjusted VLBI antenna reference points and axis offsets should be included in the survey. This requires a clear definition of the reference temperature ([Böhm et al., 2008](#), [Heinkelmann et al., 2008](#)).

The footprint network should meet the following criteria:

- At least three ground monuments should be located around the site at a distance of 10–30 km from the station.
- The network should be surveyed at least once every five years, with annual surveys for the first two years after the installation of the network.

A VLBI2010 station must be equipped with the following systems:

- an antenna designed and equipped in accordance with the VLBI2010 system specifications,
- a GNSS receiver that meets the IGS requirements and is connected to the station frequency standard,
- an eight-hour uninterruptible power supply (battery plus generator) to handle all system functions including antenna movement,
- rooms and equipment for station maintenance and repair,
- local geodetic network,
- a meteorological system:
 - The meteorological station must provide automated digital measurements of the following parameters with the respective minimum accuracies:

- temperature 0.5°C,
- pressure 0.5 hPa,
- relative humidity 5%.
- Regular calibration of the meteorological instrumentation must be performed.
- The geocentric position of all meteorological sensors must be provided with an error of less than 0.5 m. Station personnel should avoid changing the position of the meteorological sensors.

If a second antenna is planned for the site, it should be placed at the station as soon as possible. If the GNSS receiver is not yet an IGS station, it should be included in the IGS network.

For further references see [Drewes \(1999\)](#) and [IGS \(2007\)](#).

4.4 Recommendations for Antenna Specifications

The specifications listed here are intended to outline the minimum requirements for an antenna system that will meet the VLBI2010 goal of 1-mm position accuracy in 24 hours. Antennas with lower sensitivity, due to, for instance, being less than 12 m in diameter or having elevated system temperature, can nonetheless play an important role in geodetic VLBI observations.

Those specifications that are frequency-dependent, such as surface accuracy and pointing accuracy, were calculated for an upper frequency limit of 32 GHz in support of possible Ka-band geodetic observations. If observations are restricted to the broadband frequency range of 2–14 GHz, the surface and pointing specifications can be relaxed by a factor of ~2.

The range of meteorological conditions over which the antenna must operate is given for some parameters in terms of local maxima and minima out of concern that requiring an antenna be able to withstand, for example, both Antarctic and Saharan temperatures would be needlessly stringent. In any case the buyer, and not the vendor, should be responsible for specifying the range.

In locations with more extreme weather conditions, a radome may make economic as well as technical sense. A radome is acceptable provided it does not degrade the sensitivity significantly (from either an increase in system temperature or a decrease in efficiency), and the antenna structure and reference point can still be tied into the local geodetic network. The fact that the sensitivity can be seriously degraded by moisture, from rainfall or melting snow, and by ice on a radome must be taken into account when considering its suitability.

The list of quantitative specifications is incomplete in that some items cannot yet be fully specified due to the need for further development work. The antenna feed, the choice of which affects the antenna optics, is the primary example.

No explicit specification is given for the magnitude or stability of the offset between the two rotation axes of the antenna mount. Requirements on the axis offset stability are implicitly covered by the specifications for the stability of the reference point and the path length through the antenna structure. Independent of the size of any axis offset, the mount must be capable of satisfying these stability specifications in a field-verifiable manner over the projected lifetime of the antenna.

Diameter: 12 m or larger.

Surface accuracy: < 0.2 mm rms combined error for primary and secondary (if any) reflectors for all pointing directions under the primary operating conditions. Provision must be made for adjusting the height and tilt of the reflector panels above the back-up structure if the surface accuracy cannot be guaranteed for 20 years without adjustment.

Antenna mount: not specified, but slew rate specification assumes az-el.

Sky coverage: full sky above 5° elevation. For an az-el mount approximately $\pm 270^\circ$ azimuth.

RF frequency range: antenna structure: 2–32 GHz.
feed/LNA: 2–18 GHz desired,
2–14 GHz required.

Aperture efficiency: > 50%

System temperature: < 40 K excluding atmospheric contribution.

Optics: not yet specified—as required to give maximum sensitivity with the feed.

Slew rates and accelerations: see Section 3.2 for specifications for a single or pair of az-el antennas.

Blind pointing accuracy: < 0.1 HPBW (half-power beamwidth) at 32 GHz (equivalent to < 20 arcsec for a 12-m dish) for primary operating conditions; < 0.3 HPBW at 32 GHz (equivalent to < 1 arcmin for a 12-m dish) for secondary operating conditions. These limits apply both to pointing to an arbitrary position on the sky and to tracking at a specified rate.

Settling time: < 1 second from 1°/s slew rate to specified pointing accuracy.

Encoder angular resolution: < 10% of the required pointing accuracy.

Primary operating conditions:

temperature: 10-year minimum to 10-year maximum
rel. humidity: 0–100% with condensation
wind speed: < 40 km/hr sustained (or < 98-percentile wind speed, if higher)
rainfall: < 50 mm/hr

Secondary operating conditions:

temperature: 10-year minimum -5°C to 10-year maximum $+5^\circ\text{C}$
rel. humidity: 0–100% with condensation
wind speed: < 80 km/hr sustained (or < 99.5-percentile wind speed, if higher)
rainfall: < 100 mm/hr

Survival conditions at stow with negligible structural damage:

temperature: 100-year minimum -5°C to 100-year maximum $+5^\circ\text{C}$
rel. humidity: 0–100% with condensation
wind speed: < 200 km/hr sustained
rainfall: < 100 mm/hr
hail: < 20-mm-diameter hailstones with < 50 km/hr wind
ice: < 30 mm thick on all exposed surfaces
seismic: < 0.3 g, horizontal and vertical
corrosion: can withstand coastal environment

Reference point definition: The geodetic reference point, or “invariant point”, is the intersection point between the fixed rotation axis and the plane that contains the moving axis and is perpendicular to the fixed axis. For an elevation-over-azimuth mount, the fixed and moving axes are the azimuth and elevation axes, respectively. If the offset between the rotation axes is zero, the reference point is the point where the axes intersect.

Reference point stability: Relative to a local geodetic network external to the antenna and its foundation, the 3-dimensional position of the reference point must be either stable or modelable, as a function of elevation and temperature (and possibly other parameters), to less than 0.3 mm rms.

Path length stability: Define the path length difference to be the difference between the arrival times (converted to length by multiplying by the speed of light) of a plane wavefront at the reference point and at the feed after passing through the antenna optics. The path length difference must be stable or modelable, as a function of elevation and temperature, to less than 0.3 mm rms for all pointing directions under primary operating conditions. Provision

should be made to mount geodetic instrumentation, such as reflectors or corner cubes, on the antenna primary and secondary reflectors and around the feed to allow measurements of path length variations for different pointing directions.

Maintenance: Mount, drives, and antenna structure should be able to withstand nearly continuous operation with more than 2,500 long slews per day. Antenna mechanical structure aside from motors and gear boxes should have a lifetime of more than 20 years. MTBF (Mean Time Between Failures) for motors and gear boxes should be larger than 2 years. Replacement and maintenance of motors and gear boxes should be convenient and inexpensive. Projected downtime for repair and maintenance of antenna and drives should be less than 10 days per year. Projected cost of annual maintenance of antenna and drives should be less than 10% of antenna capital cost.

Recommendations on antenna control and cable wrap are given in [Himwich and Corey \(2009\)](#).

4.5 Antenna Feed

In order to maintain high aperture efficiency over 2–14 GHz, the beamwidth and phase center location of the VLBI2010 feed need to be nearly independent of frequency, and the polarization purity must be good. No circular polarization feed with these properties is known to exist or to be under development. The VLBI2010 feed will therefore be a dual linear polarization feed.

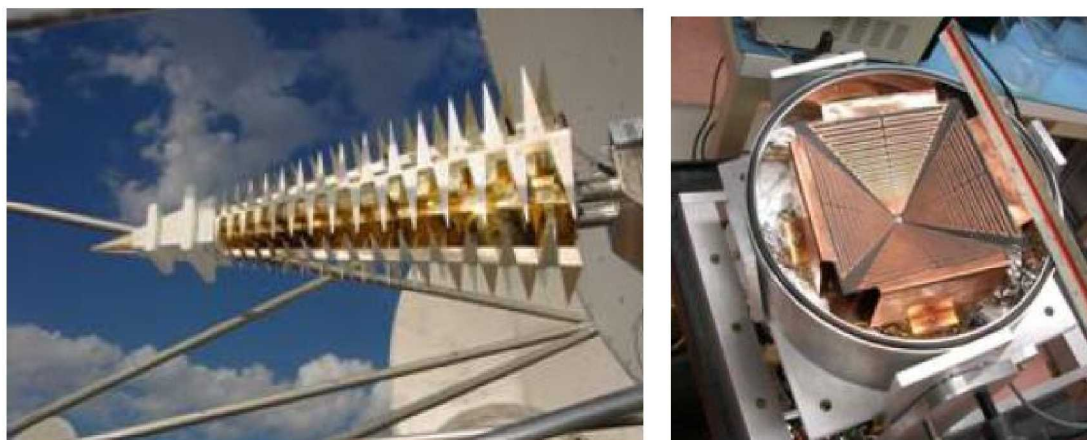

Figure 4-2. Left: ATA feed installed on an ATA dish. Right: Prototype Eleven feed in a cryogenic dewar.

Several feeds with beam patterns and phase centers that vary little with wavelength are in various stages of development. Among them are the so-called Eleven feed (Figure 4-2), which is a log-periodic, folded-dipole feed (Chalmers), a quasi-self-complementary feed (Cornell), and an inverted conical sinuous feed (NRAO). All of these are compact and can be installed and cooled to cryogenic temperatures inside a dewar ([Imbriale et al., 2007](#)). None of these feeds has progressed past the prototype stage, and there are still significant technical issues to be resolved, including how to maintain mechanical integrity when cooled to cryogenic temperatures, how to integrate the LNA with the feed structure, and how high the frequency range can be pushed with satisfactory performance. The V2C is monitoring these developments closely.

The dual-polarization ETS-Lindgren feed being used in the proof-of-concept tests (Section 5) is a fallback candidate for VLBI2010. Its advantage is that it is available commercially now. Its disadvantages include strong wavelength dependence and asymmetry of the beam patterns with significant cross-polarization, all of which impact aperture efficiency. Tests at JPL ([Imbriale et al.,](#)

[2007](#)) have shown that putting the feed inside a cylinder (such as a dewar), and adding absorber either to the interior cylinder walls or to the feed itself, improves the beam patterns. The second fallback candidate is the log-periodic pyramidal Allen Telescope Array (ATA) feed. Its design is mature, and feeds have been installed on 42 ATA antennas (Figure 4-2). A drawback of the ATA design is frequency dependence of the phase center location along the feed axis, with attendant frequency-dependent efficiency losses when observing over a wide frequency range.

4.6 Polarization

The VLBI2010 antenna feed will be sensitive to linear polarization instead of the traditional circular polarization of most current VLBI feeds (Section 4.5). A disadvantage of linear feeds in VLBI is the sinusoidal dependence of the fringe amplitude on the varying feed angle difference between antennas: as the Earth rotates, the orientation of a feed on an az-el or x-y mount changes with respect to the radio source, and for two widely separated antennas, the difference in feed angles can be 90° , with a corresponding null in fringe visibility. This problem can be avoided by employing dual-polarization feeds. An alternative is to rotate single-polarization feeds axially so that all feeds in a VLBI network maintain the same orientation on the sky. The operational feasibility of this approach is yet to be ascertained.

While no one has yet found a way to build a good broadband circular feed, it is possible to construct a circular signal from the two linear signals after digitization. This could be done in the DBE by applying a 90° phase shift to one signal and then adding it to the other. Or it could be done after correlation if all four cross products between the two linear signals are processed ([Corey, 2007](#)).

A complication of constructing a circular signal after the feed, whether at the station or at the correlator, is the inevitable differences in the analog instrumental gain and phase for the two polarization channels after the feed. For instance, if the gain for one polarization is much higher than for the other, the signal created by phase-shifting and summing the two will be dominated by the high-gain channel and so will effectively remain a linearly polarized signal. The relative gains and phases between the two channels must therefore be measured, and their effects corrected for prior to constructing the circular signal. There are several options for carrying out the measurements, ranging from observations of carefully selected radio sources to the use of phase/noise calibration methods, or combinations thereof.

4.7 Phase and Cable Calibration

The primary purpose of the phase calibration system is to measure the instrumental phase/delay response. For most applications only temporal variations are of interest, but for a few critical applications, such as UT1 measurement and time transfer, knowledge of the absolute delays is also required. For VLBI2010, the specification on the instrumental delay measurement error has been set to < 1 ps, so that it is well below the single-observation stochastic error, which is targeted to be 4 ps.

In current geodetic VLBI systems, instrumental delays are measured using a pulse calibration system. A spectrally pure 5 or 500 MHz signal is transmitted by cable to the receiver, where it triggers a tunnel diode to generate pulses with very fast (~ 30 ps) rise times. The pulses are injected into the signal path prior to the first LNA and accompany the signal through to digitization, after which the phases of the tones are extracted.

A similar system is envisioned for the VLBI2010 system. Commercial sources for tunnel diodes have become scarce, however, and the long-term availability of diodes is a serious concern.

Alternative designs for pulse generators employing high-speed digital logic gates and/or comparators are under development, and results obtained with prototypes are extremely encouraging (e.g., [Rogers, 2008](#)). The physical location of the pulse generator could be either on the antenna, with the reference signal carried to it over coax or fiber, or in the control room, with the RF pulses sent to the antenna over fiber.

The phase cal injection point may be between the feed and LNA, as in current S/X systems, or it could be moved ahead of the feed or immediately after the LNA. These options are being investigated with the NASA proof-of-concept system (Section 5). Injecting phase cal ahead of the feed has the advantage of putting more of the VLBI signal path in the calibration loop, but multipath may be a problem. All three options include in the calibration those system components with the largest phase variations: long cables subject to varying temperature or mechanical stress (as in an antenna cable wrap) and high-frequency local oscillators (LOs), which are prone to be temperature-sensitive.

Two options for the means of extracting the phase and amplitude of the calibration tones are under consideration. Both could be implemented in the DBE or at the correlator.

- If the RF phase cal and total LO frequencies ahead of the detection point are integral multiples of 5 MHz, say, then the phase cal signal will repeat every 200 ns, and the sampled data can be binned and averaged over a 200-ns interval. The FFT of the averaged signal then yields the amplitude and phase of each phase cal tone.
- Should the above conditions on the frequencies not hold, the phase cal information can be extracted using standard, dedicated tone detectors of the type employed in many geodetic acquisition systems (e.g., Mark IV, VLBA, S2) and correlators.

If the electrical path length between the maser and the pulse cal injection point varies excessively, it must be measured, and its effect on the extracted phases subtracted. The precision of the current Mark IV cable measurement system is inadequate for VLBI2010 on time scales under a few minutes. Other designs with the requisite sub-picosecond precision have been developed for geodetic and astronomical applications and could be adopted, with modification, for VLBI2010. It is possible, however, that a cable system may not be necessary if optical fiber or coax cables with low temperature and mechanical stress sensitivities are selected, and if the antenna cable wrap imparts low stress on the cables.

4.8 Noise Calibration

In addition to the new pulse calibration system, a new noise calibration system is also planned. As in current systems, it will be based on a calibrated noise diode, but in the new version it will use the 80 Hz synchronous detection process that has become standard in radio astronomy. An upgraded noise calibration system is essential to support the source structure corrections contemplated for VLBI2010 (Section 3.7). As with the pulse calibration system, the injection point for the calibration signal remains an open question.

4.9 Digital Back End (DBE) Functions

Traditionally, a VLBI back end uses primarily analog electronics. However, due to advances in digital electronics, it is now cost effective to sample the IF signal directly and do sub-band processing digitally. This approach has been under development for several years and is now about to be deployed in mainstream geodetic VLBI systems. Two options exist. Either the digital processing completely replaces current analog baseband converters (BBC), one digital algorithm per effective BBC, or a polyphase filter plus fast Fourier transform (PPF&FFT) is used, with all

output channels available simultaneously, albeit with restrictions relating to the customizing of sub-band frequencies and bandwidths. The latter option, which is very cost effective, is favored for VLBI2010.

This section discusses important functions to be considered for inclusion in the VLBI2010 DBE ([Petrachenko, 2008d](#)).

- *Anti-alias filter.* To handle the proposed VLBI2010 1-GHz bandwidth, the DBE anti-alias filters should be 1024 MHz wide. Whether the first, second, or higher Nyquist zone is used will depend on the details of the preceding down-conversion system and the bandwidth of the sampler.
- *Sampler.* The sampler clock frequency should be 2048 MHz, or a harmonic thereof. The sampler bandwidth should be as large as possible in order to maximize the number of available Nyquist zones. In addition, since the VLBI signals will be re-quantized to 1 or 2 bits after the PPF&FFT (see next item), it is necessary that the sampler resolution be significantly greater than that to avoid second-quantization loss. In the absence of RFI a practical sampler resolution might be 4 bits, with each additional bit providing 6 dB of headroom for RFI. At least 8 (and preferably 10) bits of resolution are recommended for the VLBI2010 sampler.
- *PPF&FFT.* The main parameter to specify for the PPF&FFT is the sub-band bandwidth. For numerical efficiency of the FFT it must be a power-of-two sub-multiple of the sample clock frequency. For efficient RFI excision and thorough spectral monitoring, narrow sub-bands are better. Although the final decision is somewhat arbitrary and may depend on downstream computations, sub-band bandwidths as low as 1 MHz are not out of the question.
- *Polarization conversion.* Although polarization processing may best be done after correlation, another option is to convert linear polarization digitally to circular polarization in the DBE (Section 4.6).
- *Re-quantizer.* For efficient transmission to the correlator, the PPF&FFT output needs to be re-quantized to 1 or 2 bits. For optimal 2-bit data the voltage magnitude threshold should be set near 1 sigma. Since performance varies slowly with threshold, wired thresholds may be adequate under many circumstances. However, the use of sub-band-specific thresholds will be more robust under suboptimal conditions and should be implemented if possible. Threshold values can be determined from sub-band power monitoring or from stream statistics (see below).
- *Corner turner.* For each output clock cycle of the PPF&FFT, data are grouped naturally as a set of complex data points, one pair per sub-band. However, distribution to correlation resources is done most efficiently if the data are re-grouped into continuous streams for each sub-band. This is referred to as corner turning and is efficiently implemented in the DBE.
- *Sub-band selection.* Not all sub-bands will necessarily be transmitted to the correlator. Sub-band selection should be flexible to allow adaptation to, e.g., changing band optimization schemes and RFI environment.
- *Burst acquisition.* In order to minimize on-source time, data need to be acquired at a rate as high as possible. These bursts of data should be buffered so they can be transmitted at a rate

matched to the storage media while the antenna is slewing to the next source. The DBE may be a convenient location for the buffering.

- *Data quality analyzer (DQA) and calibration.* Different DQA and calibration functions are performed most naturally at different points in the signal processing path, e.g., prior to PPF&FFT, between PPF&FFT and re-quantization, or after re-quantization. The most important functions are:
 - *Phase cal detection.* Phase cal detection can be implemented in the DBE or at the correlator (Section 4.7). Since it provides an accurate indication of end-to-end system coherence, which must be achieved for successful correlation, it is an invaluable diagnostic at the station. At least some phase cal detection capability is essential at the station.
 - *Full-band power monitoring.* Power detection of the input signal is required both for radiometry and for setting the sampler input power to near an optimal level. Since the front end noise diode will be switched on and off rapidly (perhaps at 80 Hz), power levels must be detected synchronously with the on/off signal.
 - *Sub-band power monitoring.* Sub-band power monitoring will be used to assist in setting the sub-band bit-truncation levels and to monitor RFI. This monitoring must be done after the PPF&FFT on each sub-band, synchronously with the noise diode on/off signal.
 - *Time-binned power monitoring.* To gain information about pulsed RFI, it may be desirable in some cases to bin power measurements into higher resolution time increments.
 - *PPF&FFT.* If additional spectral information is required, a second level PPF&FFT can be applied on a selected sub-band basis.
 - *Stream statistics.* After the re-quantizer, the number of data points in each re-quantized state is counted.

4.10 Correlator

Possibilities for a VLBI2010 correlator include a full custom hardware correlator, an adaptation of an existing hardware correlator, a software correlator, and a hybrid correlator, wherein FPGAs perform the most compute-intensive functions and software does the rest. All have their merits, either for a transition period or for the long term, although a full custom correlator is probably a poor choice, given its long development time and the availability of other options. The flexibility and ease of implementation of a software correlator make it the preferred option (e.g., [Deller et al., 2007](#)).

In its initial operation VLBI2010 will probably involve no more than 24 stations and a sustained data rate of 4 Gbps. A preliminary estimate of requirements for a VLBI2010 software correlator indicates that this is in fact a viable option (Briskin, 2008).

5 NASA Proof-of-Concept Demonstration

5.1 Description of the NASA Broadband Delay Proof-of-Concept System

A key new element of VLBI2010 is the broadband delay (Section 3.3). In order to demonstrate that the concept is feasible, all of the components of the broadband delay system have been

implemented on two antennas, the 18-m antenna at the Haystack Observatory in Westford, Massachusetts, and the 5-m MV-3 antenna at the NASA Goddard Space Flight Center in Maryland, a baseline of 597 km. The combined effective collecting area of these two antennas is somewhat less than that of two 12-m antennas but should be sufficient to validate the concept.

To receive the multiple bands required by the broadband delay technique, the proof-of-concept system uses a feed that covers the range ~ 2 GHz to ~ 14 GHz in two linear polarizations. The feed for the initial tests is the ETS-Lindgren Model 3164-05, a commercial wideband feed. This feed was chosen because it is readily available and relatively inexpensive. It is known that the particular combinations of the commercial wideband feed and the optics of both MV-3, which is Cassegrain, and Westford, which is used in a prime focus configuration, are far from optimum. To eliminate unacceptable ohmic losses at higher frequencies, the feed is cooled to approximately 20 K in a cryogenic dewar ([Imbriale et al., 2007](#)). See Figure 5-1 for an overview of the full system.

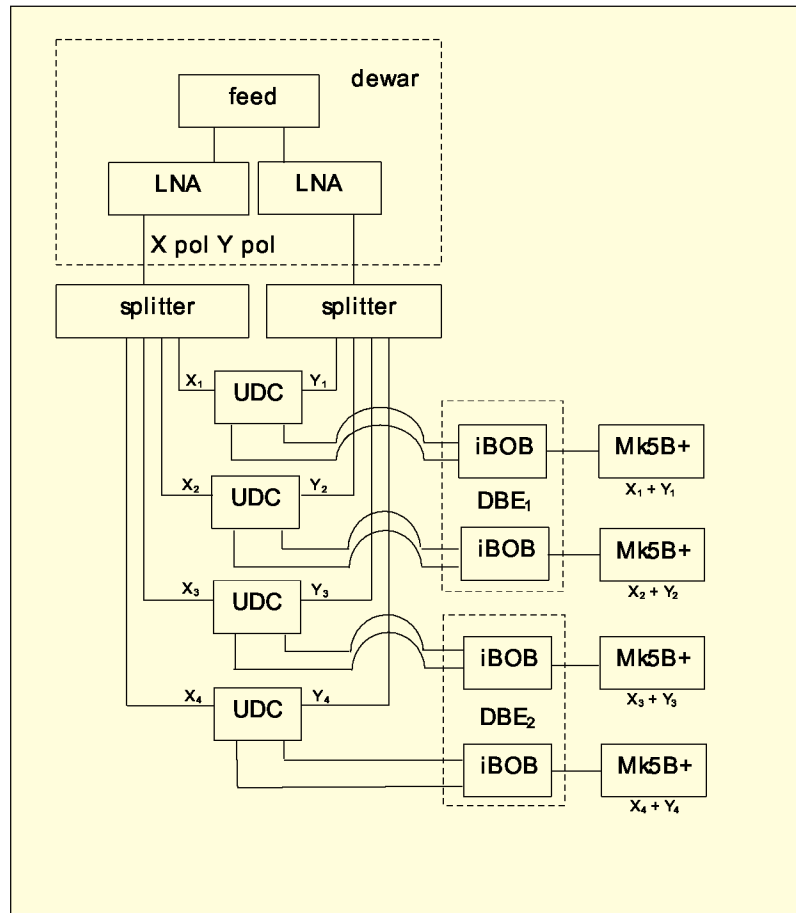

Figure 5-1. Diagram of the main components of the broadband delay data acquisition chains from feed through data recorder. The Dewar containing the feed and LNAs is mounted on the antenna. The components from the splitters down are located in the control room.

Following the feed in the dewar are, for each polarization, a high-pass filter, a directional coupler, and a low noise amplifier. As part of the VLBI2010 effort a new phase calibration generator has been developed that relies on digital components, rather than the tunnel diode used for the Mark IV version ([Rogers, 2008](#)). The output is injected through the directional coupler in each path. The rail

spacing is currently 5 MHz, although 10 MHz spacing is also being considered. Injection of a noise diode signal for amplitude calibration is planned.

The RF signal for each polarization is carried from the dewar to the control room on a separate optical fiber. In the control room, following the optical fiber receiver, each RF polarization channel is divided into four branches. The two polarizations from each band are then processed through the UDC, DBE, and recorder as a pair.

The UDC utilizes a common oscillator for two channels, one for each polarization of a band. This reduces phase differences between the polarizations as well as cost. The IF filter for each channel is 2 GHz wide. It is possible to output the signals for two Nyquist zones (NZ) in both channels of the UDC with independent programmable total gain for each of the four channels. For the broadband system demonstration, only one Nyquist zone for each polarization is selected after down-conversion and passed to the DBE. To match the current capability of the DBE, the NZ filters are 512 MHz wide.

The bandwidth-limited signals from both polarizations of one band are input to a two-channel, eight-bit analog-to-digital converter (ADC) in the DBE. The sampled data are passed to the [iBOB](http://casper.berkeley.edu/wiki/index.php/IBOB) (interconnect break-out board; <http://casper.berkeley.edu/wiki/index.php/IBOB>) containing the FPGA chip which, for this application, outputs sixteen two-bit 32-MHz-wide channels for each polarization. The iBOB is a product of the Center for Astronomy Signal Processing and Electronics Research group at UC Berkeley, and the DBE is a joint development of that group and MIT Haystack Observatory. In order to keep the number of recorders to four at each site, the eight odd-numbered 32-MHz channels from each polarization are combined on one of the two VLBI standard interface ([VSI](http://www.haystack.mit.edu/tech/vlbi/vsi/index.html), <http://www.haystack.mit.edu/tech/vlbi/vsi/index.html>) outputs from the iBOB for a data rate to each Mark 5B+ recorder of ~ 2 Gbps. With four recorders the total data rate is ~ 8 Gbps at each site. The rate for each polarization of each band is ~ 1 Gbps.

5.2 Results and Current Status

Several tests have been conducted with the broadband systems. In the first group of tests, only MV-3 had the broadband VLBI2010 system, while Westford used the standard circularly polarized S/X feed, amplifier, and local oscillator, but with its X-band output split eight ways and fed directly to the DBEs. All four bands at both antennas were set to record the same X-band frequency range, ~ 8.6 - 9.1 GHz. The primary purpose of the initial tests was to demonstrate the functionality of the broadband system. However, the mixed broadband and S/X operating mode is also of interest since it will be required during the transition to VLBI2010 operations when networks include some antennas with standard S/X capability while others are equipped with broadband systems.

For this first group of tests, most of the broadband components of the proposed VLBI2010 system were mounted on MV-3. However, there was no phase cal at that time, and one channel was carried on coaxial cable instead of optical fiber. Linear polarization was recorded at MV-3 and circular at Westford. First fringes were found Nov 19, 2007, and a six-hour observation of the source 3C84 was made on Jan 4, 2008. From these sessions and the preceding single antenna measurements, several things were learned. a) Television signals near 520 MHz can saturate the LNAs and may be strong enough to damage them. b) The efficiency of MV-3 at X-band is about one-third the expected value. c) The VLBI fringe amplitudes and the SNRs agree within 10% with the values expected from the single dish measurements at each site. A temporal variation in phase difference between the two polarizations at MV-3 was found, but without phase cal the cause could not be isolated. The most likely cause was different responses of the optical fiber and the coax cable to temperature change.

Having verified functional operation during the initial tests, a dewar and set of UDCs were replicated for Westford. VLBI observations were then carried out with VLBI2010 systems at both sites, now also including phase cal and optical fiber for both polarizations. It was found that Westford is also severely affected by the TV signals, and concern was raised that the LNAs might be damaged, not just by the TV but by a nearby radar at 1.295 GHz. A decision was made to install protective diodes in the LNAs and high-pass filters were installed in the dewars at the outputs of the feeds. Although a low frequency cutoff of 3.1 GHz is currently being used for the high-pass filters, a better filter with a frequency cutoff low enough to allow S-band observations will be included at a later stage of development.

Currently the phase cal signal is generated by a Mark IV unit that was modified to produce a tone spacing of 5 MHz. Initially the signal was injected through a probe mounted just in front of the dewar window, but, because of concern about the stability and balance of power between the polarizations, the signal is now split and injected through directional couplers (one for each polarization channel) following the filters inside the dewar.

The UDCs allow a great deal of flexibility in the choice of frequency for each band, so observations have been made in several modes to evaluate the internal consistency of the four UDC/DBE/Mark-5B+ channels and to sample the response over much of the RF range that is accessible. Fringes have been detected from ~3.4 GHz to ~9 GHz, but at the time of writing the phase characteristics have not yet been analyzed.

As noted above, the sensitivity of MV-3 was found to be only about one-third the expected value when the dewar was installed. Attempts to improve the efficiency by determining an optimum focus setting have not been successful. Measurements of the shape of the primary surface and the sub-reflector show that the sub-reflector is not correct for the paraboloidal main reflector. It is unclear if the low efficiency is due to the mismatched sub-reflector, to improper illumination of the sub-reflector by the Lindgren feed, to both, or to other problems. At Westford the sensitivity was improved in a band near 4 GHz by adjusting the focus based on observations of a satellite, but this appears to have reduced the sensitivity at higher frequencies. Maximizing the sensitivity for the systems as they currently exist, for example by finding the best focus settings, is a high priority. Whether major modifications, such as changing the sub-reflector at MV-3, will be made will require additional modeling and measurements of the beam pattern of the dewar/feed combination.

5.3 Plans

The next steps will include installing the new phase calibrator, improving our understanding of the requirements of the operating parameters for the DBE, maximizing the sensitivities of the antennas, obtaining observations spanning the full available frequency range, and developing optimum analysis procedures for estimating the delay for the dual linear-polarization observations.

The main component that requires further development for the prototype demonstration is the broadband feed. The commercial version being used for these demonstrations is not matched to the antenna geometry, and both the beamwidth and the phase center are frequency dependent. As soon as a candidate is available, it will be installed on one of the two antennas for evaluation.

For the anticipated operational VLBI2010 system the second generation of DBE and recorder are under development. The DBE2 will have significant additional capability and functionality, including phase cal and noise cal extraction for better phase and amplitude calibration. The DBE2 and Mark 5C ([Whitney, 2008](#)) recorder will transfer data via 10 Gbps Ethernet, allowing 4 Gbps recording on one Mark 5C. These components will be utilized in the broadband demonstrations as they become available.

6 Operational Considerations

In this section issues related to VLBI2010 operations are considered. The operational challenges of meeting the VLBI2010 requirements for continuous observations, latency of less than 24 hours to initial geodetic products, and a manifold increase in data volume are given particular attention.

Section 6.1 outlines an observing strategy to meet the needs of VLBI2010, and Section 6.2 summarizes how the transition from current operations to VLBI2010 can be effected. Sections 6.3 and 6.4 discuss automation in data acquisition and analysis, Section 6.5 introduces the IVS Working Group 4 effort to modernize VLBI data structures, and Sections 6.6 and 6.7 treat data transmission from the antennas to the correlator.

6.1 Observing Strategy

An observing strategy for VLBI2010 must:

- yield TRF, CRF, and EOP data products of the requisite quality,
- fulfill the VLBI2010 requirements for continuous observations and latency of less than 24 hours to initial geodetic products,
- allow for station maintenance and repair,
- allow for research and development (R&D),
- be affordable and sustainable,
- enable an integrated use of legacy and special purpose antennas with VLBI2010 antennas.

At the heart of the observing strategy for VLBI2010 are the acquisition, correlation, and reduction of data from a globally distributed subset of 16 VLBI2010-compliant stations to produce continuous, high-quality EOP ([Petrachenko, 2007](#)). A smaller number of these antennas must have access to a cost-effective high-speed fiber optic network to meet the VLBI2010 requirement for less than 24 hour turnaround time from observations to initial geodetic products. The antennas that are not observing are available for station maintenance and, if necessary, repair. In general, each station strives for as continuous a data set as possible in order to better understand and reduce systematic effects that limit accuracy.

The key to extending these observations to enhance CRF and TRF, and to provide opportunity for R&D is the development of a correlator capacity that can handle significantly more sites than is needed just for daily determination of EOP. While it is desirable that most of the extra antennas in each day's observing meet the VLBI2010 slew rate specification, the additional correlator capacity will also allow legacy antennas and special purpose antennas, such as those with large collecting area, to be included. Incorporating the added antennas into integrated observing schedules that overlap with the daily EOP schedules will enhance the connection to the stations that observe on a daily basis and hence have well established locations. The legacy and special purpose IVS antennas will have their own, unique roles in the VLBI2010 era, as they will:

- allow continuation of long legacy data records,
- extend the VLBI TRF for better global coverage,
- allow regional studies,
- extend the CRF to weaker sources,
- extend the CRF to higher frequency bands such as K, Ka, and Q (15, 32, and 43 GHz, respectively).

6.2 Transition Plan

The transition from current S/X observations to VLBI2010 observations is constrained by the IVS requirement for continuous operational products, so it is not permissible to shut down operations completely during the transition. Validating the new system against the old is also critical, in order to avoid systematic offsets between the products from the new and old systems.

The key to a successful transition plan is the inclusion of VLBI2010 operating modes that are backward compatible with legacy S/X systems. As they come on line, VLBI2010 sites can then observe seamlessly with S/X sites. Mixed S/X-VLBI2010 observations have already been demonstrated, under limited conditions, as part of the NASA proof-of-concept project (Section 5).

Three stages of transition to VLBI2010 operations are anticipated ([Malkin, 2007](#)):

- The number of VLBI2010 stations is still small, say 2–5. At this stage, most VLBI2010-only sessions will be of an R&D nature for the purpose of investigating and optimizing station operations, optimal scheduling, data acquisition, data transfer, correlator operations, and automated data analysis. New antennas will also be incorporated into the existing S/X networks and observing programs to enhance the IVS network and to connect new antenna locations with the VLBI TRF.
- The number of VLBI2010 stations is intermediate, say 6–15. At this stage the VLBI2010 network will be running independent programs for EOP, TRF, and CRF, and legacy antennas will continue the current observing programs aimed at the same IVS products. Some sessions will use mixed networks of S/X and broadband stations, and the ties between the current and new networks will be strengthened. Comparisons of the EOP and CRF data products obtained with the old and new technologies will also become possible.
- The number of new stations is 16+ with good distribution over the globe. At this stage the new observing strategies discussed in Section 6.1 can be put into practice.

6.3 System Automation

One of the main impediments to the expansion of VLBI operations is the comparatively (vis-à-vis GNSS, for instance) large number of personnel needed at each site. High priorities in designing VLBI2010 have therefore been the development of systems that are robust and easy to repair, and the inclusion of automation into as many aspects as possible of VLBI processes, including schedule generation, station operations, and data analysis, the last of which is discussed in more detail in Section 6.4.

Current station operations are already automated to a large extent in that a software “field system” monitors and controls most of the station hardware from the antenna through the data recorder. However, personnel are still needed on site to download and start schedules, to load and unload record media, and to repair or reset malfunctioning subsystems, among other tasks. At most stations, personnel are expected to be on site continuously during operations.

In contrast, the vision of VLBI2010 station operations is that personnel will be required to be on site only to change and ship record media once per day at most, to perform maintenance periodically, and to make repairs as necessary, but otherwise will be only on call during operations, and possibly not on site. To turn this vision into reality, systems and processes must be engineered to have a much higher level of reliability than at present, and procedures need to be put in place to identify anomalous conditions and to alert on-call personnel when their presence is required on site. Identification of anomalous conditions requires that features be incorporated in the hardware for

thorough testing of all subsystems and that software be put in place to automatically and thoroughly check the system on a regular basis.

An important innovation for VLBI2010 station operations is the development of a control center that is in constant communication with all stations actively involved in observations. For convenience it is possible for the control center to be transferred from location to location around the globe to follow daylight hours. To avoid problems when communication lines fail, each station will still be controlled by an on-site schedule file. However, the control center will be able to download and start new schedules, re-calculate schedules when network conditions change due to, for example, a failed station, monitor and control all subsystem functions, reset subsystems when they malfunction, and contact on-call personnel when hands-on intervention is required. Centralized monitor and control of the entire network will have the added advantage of ensuring that configurations at all sites are compatible.

6.4 Analysis Automation

An integral part of the VLBI2010 concept is (near)-real-time correlation processing for a subset of stations followed by rapid automated analysis for EOP determination. A seamless data flow is required from antenna back end to the uploading of EOP to the combination centers. To this end, reliable automated procedures will be needed at all stages of the VLBI data processing. Where these procedures do not exist, they need to be developed. Where they do exist, they need to be reviewed, updated as necessary, and integrated into a coherent VLBI2010 analysis process ([Malkin, 2008b](#)).

The set of operational data analysis tasks required for determination of EOP includes the following steps:

- Retrieve data files from the correlator and/or IVS data center.
- Compute and apply ionosphere correction.
- Resolve ambiguities.
- Interpolate meteorological parameters to the epochs of the observed scans.
- Retrieve or compute in situ other data used for analysis, such as a priori EOP, atmospheric loading, mapping function, tropospheric gradients, and master file.
- Perform estimation of parameters.
- Perform quality check.
- Upload results to IVS data center.

During EOP computation, the analyst usually needs to solve several tasks, as a rule in an interactive mode:

- choice of clock reference station,
- elimination of outliers,
- detection of clock breaks,
- cable calibration data handling,
- adjustment of parameterization,
- detection of abnormal station behavior and corresponding adjustment of the estimation

procedure.

Many steps listed above are fully or partly automated at different IVS analysis centers and correlators, while others are under development. Partially automated computation of UT1 from Intensive sessions was implemented at the Institute of Applied Astronomy (IAA) IVS Analysis Center in 2001 ([Malkin et al., 2002](#); Malkin and Skurikhina, 2005). Advanced automated analysis procedures, which include earlier steps such as ambiguity resolution and thus cover the entire data path from correlation to UT1, were recently developed at the Kashima Space Research Center ([Koyama et al., 2008](#)).

However, the automated analysis of 24-hour sessions, with computation of the full set of EOP along with troposphere and other parameters of interest, is a more complicated task, and analysis of these sessions often requires that decisions be made by the analyst. Experience shows that about 99% of Intensive sessions processed in the automated mode do not require re-visiting by an analyst, whereas only 80–85% of 24-hour sessions give satisfactory results if processed in a semi-automated mode. The rest of the sessions require manual intervention, mainly due to clock breaks and, to a lesser extent, due to other reasons such as choice of the clock reference station or excessive station noise.

To make automated data analysis simpler and more reliable, the formats of all operational files, such as station logs, meteorological data files, and correlator reports, need to be reviewed and standardized (Section 6.5).

6.5 New Data Structures

IVS Working Group 4 (WG4) on Data Structures was established at the 15 September 2007 IVS Directing Board meeting. The purpose of WG4 is to design a replacement for the current VLBI database.

Any new data structure must be able to store the data currently required to process VLBI sessions as well as to handle the needs of VLBI2010. The following summarizes some initial goals for a new format.

- *Compact.* The structure should minimize redundancy.
- *Accessible.* Users should be able to easily access the data without the need of custom software.
- *Different languages/different platforms.* The same structure should be accessible on different operating systems and by different languages.
- *Speed.* One should be able to add, modify, and retrieve data quickly.
- *Extensible.* It should be possible to add new data types, e.g., source structure maps, system temperatures, and system gain information.
- *Provenance.* Analysts should be able to retrieve the origin and history of the data.
- *Completeness.* The data structure should include all of the information necessary to process VLBI data from start to finish. Analysts should be able to redo the analysis from start to finish.
- *Different levels of abstraction.* There are many different kinds of users of VLBI data. The new structure should serve all of them. Many users may be interested only in the final delay. Experts may want access to data from an earlier processing stage.

6.6 Shipping and Media Requirements

A major operating expense for VLBI is the cost of shipping media between stations and correlators. VLBI2010 will be no different in this regard, as sensitivity trade-offs required to allow smaller, faster-slewing antennas lead to the need for significantly higher data volumes.

The current state of the art for data storage on affordable 3.5" high density disks (HDDs) is 1 TB. With the advent of new technologies, that capacity is expected to grow to 4 TB by 2011. A 32-TB 8-pack of 3.5" HDDs can therefore be considered a reasonable unit of disk storage at the anticipated start of significant VLBI2010 operations in 2012.

Based on the sensitivity considerations in Section 3.1, it is possible to calculate the number of 32-TB disk packs needed per day for a variety of operating conditions (Petrachenko, 2008c). As an example, Figure 6-1 shows the relationship between the number of disk packs needed per day and N , the number of observed sources, where the sources are selected from the Petrov list (cf. Section 2.2) by decreasing flux density, i.e., only the strongest N sources in the list are used. As expected, as N increases, the average flux density decreases and hence more disk packs are needed per day. Plots are displayed for SNR targets of 10 and 14 and for typical source-switching intervals of 45 and 60 s.

For a typical operating scenario of six days observation and one day maintenance per week and a four-week buffer of recording media at each site, Figure 6-1 can be used to show that a media pool between 4 and 28 32-TB 8-packs is required per site. For the same operating scenario, between 100 and 720 one-way 8-pack shipments is required per site per year.

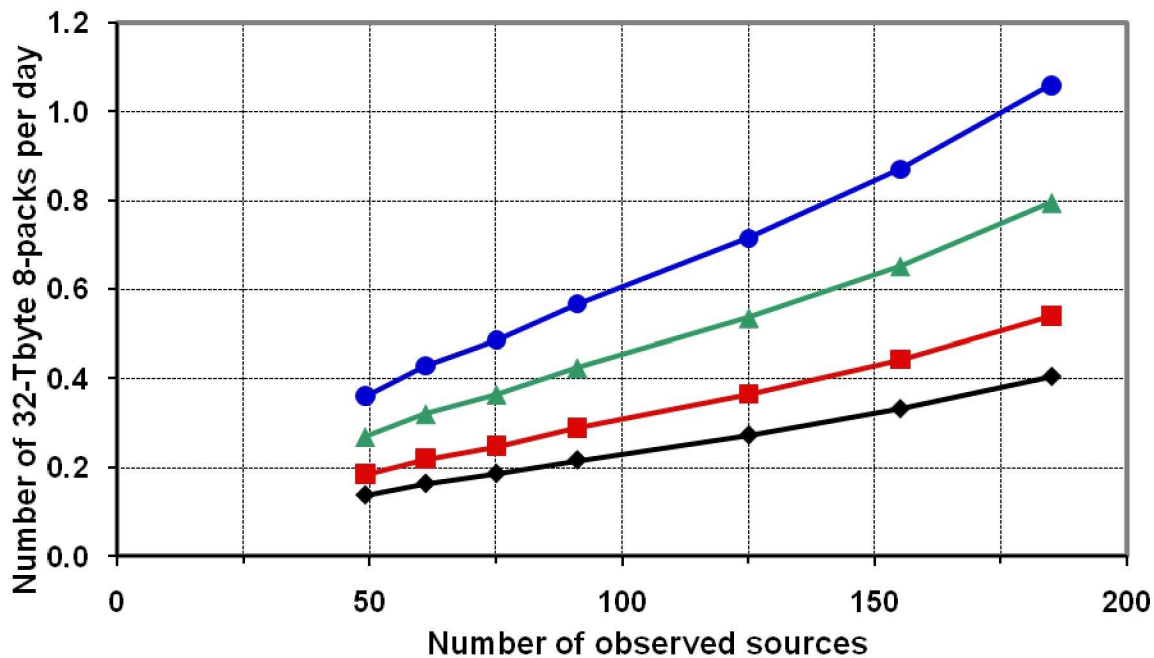

Figure 6-1. The number of 32-TB disk packs needed per day is plotted relative to N , the number of observed sources, where the sources are selected from the Petrov list by decreasing flux density. The SNR targets and source-switching intervals of the four scenarios are, from top curve to bottom: a) SNR=14 and $\Delta T_{SRC}=45$ s, b) SNR=14 and $\Delta T_{SRC}=60$ s, c) SNR=10 and $\Delta T_{SRC}=45$ s, d) SNR=10 and $\Delta T_{SRC}=60$ s.

These requirements can be expected to ease with time as disk capacity continues to increase. However, in the meantime, less demanding operating modes may be required.

6.7 e-VLBI

As can be inferred from Section 6.6, VLBI2010 operations starting in ~2012 could be supported at sustained data rates between 0.5 and 3.5 Gbps/station/day with traditional recording and shipping of disk modules. However, the cost of such a mode of operation is substantial, unmanned operation of sites is largely precluded, and processing turnaround times are a minimum of several days.

Although unproven for continuous VLBI operations at these sustained data rates, a more desirable mode of data transport is electronic transmission of data (“e-VLBI”), which would dramatically reduce processing turnaround time and allow fully automated station operation. The 10-Gbps data interfaces being designed into the VLBI2010 system lend themselves naturally to network data transport and are well matched to the projected operational sustained data rates. Furthermore, most modern fiber networks are designed to support the multiplexing of many (up to 100 or more) individual optical wavelengths onto a single fiber with each wavelength typically supporting 10 Gbps.

For stations with suitable fiber connections to the correlator, data processing can take place in real-time or near-real-time, and a core subset of stations must be connected in this way to support time-critical EOP measurements. The data from this subset of stations may also need to be recorded at the correlator if subsequent correlation with shipped data from other stations is required. A fallback position for time-critical EOP operations where one or more stations are connected at less than real-time data rates would be post-observation e-VLBI transfer of data at lower speeds and recording on disks located at the correlator facility, as is currently done to support time-critical Intensive EOP processing.

The costs of installing and supporting e-VLBI data transfer will vary widely depending on several factors, including “last-mile” fiber installation costs (where necessary) as well as recurring usage or lease charges. Access to government-supported or research-and-engineering (R&E) networks will almost certainly be required within the foreseeable future to keep the latter costs to an acceptable level. It is difficult at this time to project such costs and how they may compare with traditional record-and-ship costs, but there is reason to be optimistic that these costs will be competitive and affordable for at least a subset of the stations.

7 Risks and Fallback Options

In this section, risks to accomplishing the goals of VLBI2010 are considered. These are divided into technical risks and organizational challenges.

7.1 Technical Risks

- *Antenna slew parameters.* Demanding slew rates are required to achieve 1-mm accuracy using a single antenna (Section 3.2). In addition to the high capital cost of fast antennas, large recurring costs related to power consumption, repair and maintenance, among other things, may be difficult to sustain. Since, as seen from Figure 3-3, the same level of performance can be achieved using a pair of slower-slewing antennas, costs and benefits of this option need to be weighed. The “two antenna” configuration has the added advantage of providing a completely redundant antenna system, making it possible to continue observations during maintenance and repair, thus providing a capability for truly continuous operation.

- *Sensitivity.* Adequate sensitivity is required to observe enough sources to establish a robust connection to the ICRF. Modern source lists include nearly 200 high-quality sources with flux densities above 250 mJy. At 250 mJy and under ideal conditions, a 12-m antenna with 50% efficiency, a system temperature of 50 K, and a data acquisition rate of 32 Gbps safely resolves broadband delay after about 10 s of integration. Real-world limitations related to RFI and source structure may seriously compromise the resolution process. Fallback options include the use of longer integrations, a higher minimum source flux density, or larger antennas. Each of these has a down side. Longer integrations increase the already high costs of shipping and media and also increase the source-switching interval with concomitant degradation in geodetic accuracy. Raising the flux density limit reduces the number of available sources and hence degrades the connection to the ICRF. Larger antennas increase capital and operating costs.
- *Data volume.* Achieving full VLBI2010 sensitivity with a 12-m antenna will require a sustained record/transfer data rate of at least 4 Gbps. Anticipated shipping and media costs for continuous observations with a network of 16 or more VLBI2010 antennas will therefore be much higher than those of today and may not be affordable at the outset. Fortunately, there is a long history of steadily increasing data storage density and transmission rate with time. As a result shipping, media, and transmission costs can be projected to decrease in the future. If necessary, in the short term, fallback observing scenarios may be required, e.g., increasing the minimum source flux density or increasing the average source-switching interval (Section 6.6).
- *Broadband delay.* Although the NASA proof-of-concept project is underway, the broadband delay technique has not been demonstrated at the time of this report. While no fundamental limitations have been identified, complications from RFI and source structure are a concern. As a fallback, options including an enhanced two-band system with a wider bandwidth in each band and wider spacing between bands have been considered ([Petrachenko, 2008a](#)). These systems can be expected to achieve on the order of 8–12 ps delay precision which, according to Figure 2-3, should not degrade performance significantly, although this large delay uncertainty may be insufficient for uncovering and understanding systematic errors.
- *RFI.* RFI is a major concern for VLBI2010 (Section 3.4), especially toward the lower end of the 2–14 GHz spectrum. The overall gain distribution of the system, sampler resolution, and digital processing algorithms are all being designed to be as robust as possible against RFI. In addition, with proper feed design, RFI from outside the band should be significantly attenuated. It is recognized that at some locations fixed input filters may be required and that flexibility of frequency selection for the broadband sequences is likely to be limited. It is expected that these precautions and limitations will result in a workable broadband system, but if all else fails, a final fallback option is an enhanced dual-band system, which may be more robust against strong RFI in regions of the spectrum that are not actively being used.
- *Operational costs.* In VLBI2010 an effort is being made to reduce operational costs through automation. This will be offset to some degree by added costs for shipping and data transmission, power, and maintenance for the fast-slewing antenna drive system and for the added operational antenna days that would be required to achieve continuous observations.
- *Network geometry.* An important aspect of VLBI2010 is the expansion of the IVS network toward a more uniform global distribution of stations. New VLBI2010 antennas are needed in all regions to improve connection to the ITRF and to improve the robustness of the ITRF scale. Therefore, a particular emphasis needs to be placed on the southern hemisphere where antennas are less plentiful. This is required to improve the CRF in the south celestial hemisphere and to reduce biases in source declination and station latitude due to global atmosphere gradients.

7.2 Organizational Challenges

Successful projects are usually characterized by well-defined requirements, agreed-upon specifications and schedules, and control of resources and personnel. The VLBI2010 project, as it stands today, has made significant progress toward establishing well-defined requirements and agreed-upon specifications. However, the voluntary nature of the IVS and the informal structure of the V2C make it difficult to move to the next phase of the project at which enforceable schedules are agreed upon and resources and personnel are committed. One model for moving forward, which has been used successfully for large international projects in other areas of science, is the establishment of a consortium of partners organized through a full-time project office. However, the comparatively small size of the VLBI2010 project, the globally dispersed distribution of potential partners, and their asynchronous and uncertain funding timelines make this approach inappropriate and perhaps excessively formal. A more suitable approach may be to organize a small project executive group. Its main responsibilities would be to establish and to maintain best-effort schedules, to solicit expressions of interest and, eventually, commitments either to specific design, development, and production tasks or to contributions of project components such as antennas, correlators, and maintenance depots. It may be useful to formalize these intentions at a level similar to that currently used for components of the IVS.

8 Next Steps

- *Continue the NASA-sponsored broadband delay development and testing effort.* It has reached the point where two progenitor VLBI2010 front end receiver and back end systems have been built and are deployed at the Westford and GGAO antennas. Initial fringes have been detected between the systems, and evaluation of their sensitivity and stability is currently under study. The next major steps to be undertaken include:
 - Study the sensitivity and stability of the system over the full available spectrum, and at the same time gather information on the local RFI environments.
 - Develop processes for combining the linearly polarized correlation products to produce group delay estimates in each band.
 - Develop processes for forming the broadband delay and study its sensitivity requirements, stability, etc., using long continuous observations of single sources.
 - Study the impact on broadband delay of switching between sources in different areas of the sky.
 - Study the impact of source structure on broadband delay.
 - Test broadband delay with a geodetic schedule.
 - Install an Eleven feed when it becomes available and test it.
 - Begin to correlate data using an implementation of a small software correlator specifically tailored for geodetic applications and VLBI2010.
- *Continue development of the VLBI2010 subsystem recommendations.* The current state of VLBI2010 subsystem definitions is presented in this report. Some are quite advanced, e.g., antenna and site recommendations, while others, e.g., DBE and correlator, are only rudimentary. In March 2009 a workshop will be held in Wettzell to decide on VLBI2010 frequencies and feeds. This will be followed by a second workshop to discuss the definition of the VLBI2010 DBE and correlator. By the start of 2010 it is intended that all required

subsystems be fully defined so that final development and prototyping can proceed for the VLBI2010 deployment.

- *Formalize the structure of the VLBI2010 project.*
 - Identify organizations to take responsibility for the design, prototyping, and production of final versions of all VLBI2010 subsystems from the feed and front end receiver to the data recorder.
 - Identify organizations to take responsibility for the design and implementation of VLBI2010 correlators.
 - Develop timelines, including identification of persons and organizations responsible for completion of tasks.
- *Promote the expansion of the VLBI2010 network.* Due to long lead times, it is important to start the process of acquiring antennas as soon as possible. In a few cases (e.g., Wettzell Twin Telescope and AuScope network), proposals have already been accepted, and detailed design or construction is underway. Groups should be solicited to fund, install, and operate antennas in regions of the globe where antennas are lacking, especially in the southern hemisphere.
- *Develop a research network to study the effectiveness of broadband delay, short source-switching intervals, atmosphere measurements and models, instrumental calibrations, antenna deformation measurements, and site ties.* The optimal network would be only a few hundred kilometers in extent, so that atmosphere conditions at the sites are independent but the effects of EOP and source structure errors are minimal. Such a network will be invaluable for refining the most effective methods for reducing random and systematic errors. Since GNSS results on the same short baseline will be comparatively free of orbit determination errors, they will provide an excellent independent comparison of performance, including site ties. Even a single baseline with VLBI2010 electronics and fast slewing antennas would be of great value. An example might be a continuation of the broadband delay proof-of-concept baseline but with dedicated fast-slewing antennas.
- *Develop a small reference antenna for monitoring antenna deformations and site ties (Section 3.6).* The development of such an antenna is not dependent on VLBI2010 electronics and could begin immediately. This approach shows great promise for a unified automatic approach to site ties, which is an integral aspect of GGOS.
- *Continue with research into scheduling strategies.* In addition to the two scheduling strategies used in the VLBI2010 simulations, further work to optimize scheduling with respect to the new operating modes and antennas is planned. A research project dealing with these issues has been started at IGG Vienna (Schuh, 2008).
- *Continue with studies of source-structure corrections.* Theoretical studies of source-structure corrections are nearly complete (Section 3.7). If the results are promising, S/X observations with the RD-VLBA network should be made to test the concepts.
- *Study VLBI2010 analysis requirements.* VLBI2010 will introduce many novelties, including a completely new observable, the broadband delay; four flexible bands instead of the usual S/X; a need for greater analysis automation; many more observations per session; and many more clock and atmosphere estimation intervals per session. Building on the analysis development for the V2C simulations and the WG4 work on data structures, the analysis enhancements required for VLBI2010 need to be identified and a plan created for their implementation.

Acknowledgements

Many people contributed in a number of different ways to the VLBI2010 project and their efforts are greatly appreciated. In particular the authors would like to thank the following persons: Tom Clark, Chopo Ma, Alan Rogers, Hayo Hase, Sandy Weinreb, Hamdi Mani, and Marshall Eubanks. The proof-of-concept demonstration has been funded by NASA's Earth Surface and Interior Focus Area through the efforts of John Labrecque, Chopo Ma, and Herb Frey. The demonstration was the result of the efforts of Bruce Whittier, Mike Titus, Jason SooHoo, Dan Smythe, Alan Rogers, Jay Redmond, Mike Poirier, Arthur Niell, Chuck Kodak, Alan Hinton, Ed Himwich, Skip Gordon, Mark Evangelista, Irv Diegel, Brian Corey, Tom Clark, and Chris Beaudoin. We thank Wolfgang Schlüter for his support at the inception of the VLBI2010 project and Harald Schuh for his continuing support in their roles as Chair of the IVS Directing Board.

The authors would like to acknowledge the generous VLBI2010-related support of their affiliated agencies.

VLBI2010 research at MIT Haystack is conducted under NASA contract NNG05HY04C.

Andrea Pany is recipient of a DOC-fFORTE fellowship of the Austrian Academy of Sciences at the Institute of Geodesy and Geophysics, Vienna University of Technology.

Jörg Wresnik is funded by the FWF Austrian Science Fund, project title: Optimum design of geodetic VLBI network and observing strategies, P18404-N10.

References

- d'Auria, G., F. S. Marzano, and U. Merlo, Model for estimating the refractive-index structure constant in clear-air intermittent turbulence, *Applied Optics*, vol. 32, pp. 2674–2680, 1993.
- Bar-Sever, Y. E., C.S. Jacobs, S. Keihm, G.E. Lanyi, C.J. Naudet, H.W. Rosenberger, T.F. Runge, A.B. Tanner, and Y. Vigue-Rodi, Atmospheric Media Calibration for the Deep Space Network, *Proc. IEEE*, vol. 95, pp. 2180–2192, 2007.
- Böhm, J., R. Heinkelmann, H. Schuh, and A. Nothnagel, Validation of Mean Temperature Values as Provided by GPT, *IVS Memorandum 2008-003v02*, 2008.
- Böhm, J., B. Werl, and H. Schuh, Troposphere mapping functions for GPS and very long baseline interferometry from European Centre for Medium-Range Weather Forecasts operational analysis data, *J. Geophys. Res.*, 111, B02406, doi:10.1029/2005JB003629, 2006.
- Böhm, J., J. Wresnik, and A. Pany, Simulation of wet zenith delays and clocks, *IVS Memorandum 2006-013v03*, 2007.
- Bolli, P., S. Montaguti, M. Negusini, P. Sarti, L. Vittuari, G.L. Deiana, Photogrammetry, Laser Scanning, Holography and Terrestrial Surveying of the Noto VLBI Dish, in *IVS 2006 General Meeting Proceedings*, ed. by D. Behrend and K. Baver, NASA/CP-2006-214140, pp. 172–176, 2006.
- Brisken, W., Software Correlation for VLBI2010, private communication, Feb. 4, 2008.
- Collioud, A. and P. Charlot, Imaging Capabilities of the Next Generation VLBI System, in *Measuring the Future – Proceedings of the Fifth IVS General Meeting*, ed. by A. Finkelstein and D. Behrend, Saint Petersburg, Nauka, ISBN 978-5-02-025332-2, pp. 433–438, 2008.
- Corey, B., Notes on Antenna Polarization and VLBI Observables, *IVS Memorandum 2007-011v01*, 2007.
- DeBoer, D., W.J. Welch, J. Dreher, J. Tarter, L. Blitz, M. Davis, M. Fleming, D. Bock, G. Bower, J. Lugtem, Girmay-Keleter, L. D'Addario, G. Harp, R. Ackermann, S. Weinreb, G. Engargiola, D. Thornton, and N. Wadefalk, The Allen Telescope Array, *Proc. SPIE Vol. 5489, Ground-based Telescopes*, J.M Oschmann (ed.), pp 1021–1028, 2004.
- Deller, A.T., S.J. Tingay, M. Bailes, C. West, DiFX: A Software Correlator for Very Long Baseline Interferometry Using Multiprocessor Computing Environments, *The Publications of the Astronomical Society of the Pacific*, Volume 119, Issue 853, pp.318–336, 2007.
- Drewes, H., The International Space Geodetic and Gravimetric Network (ISGN). In: G. Beutler, H. Drewes, H. Hornik (Eds.): *Commission VIII - International Coordination of Space Techniques for Geodesy and Geodynamics (CSTG)*, Progress Report 1998. IAG CSTG Bulletin No. 15, 13–15, DGFI, Munich 1999.
- Elgered, G., J. L. Davis, T. A. Herring, and I. I. Shapiro, Geodesy by Radio Interferometry: Water Vapor Radiometry for Estimation of the Wet Delay, *Radio Sc.*, vol. 96, pp. 6541-6555, 1991.
- Emardson, T. R., G. Elgered, and J. M. Johansson, External Atmospheric Correction in Geodetic Very-Long-Baseline Interferometry, *J. Geodesy*, vol. 73, pp. 375-383, 1999.
- Eresmaa, R., S. Healy, H. Jaervinen, and K. Salonen, Implementation of a ray-tracing operator for ground-based GPS Slant Delay observation modeling, *J. Geophys. Res.*, 113, D11114, doi:10.1029/2007JD009256, 2008.

- Fey, A. and P. Charlot, VLBA Observations of Radio Reference Frame Sources. II. Astrometric Suitability Based on Observed Structure, *The Astrophysical Journal Supplement Series*, vol. 111, pp. 95–142, 1997.
- Fey, A. and P. Charlot, VLBA Observations of Radio Reference Frame Sources. III. Astrometric Suitability of an Additional 225 Sources, *The Astrophysical Journal Supplement Series*, vol. 128, pp. 17–83, 2000.
- Fomalont, E., VLBA Phase Referencing for Astrometric Use, in *IVS 2006 General Meeting Proceedings*, ed. by D. Behrend and K. Baver, NASA/CP-2006-214140, pp. 307–315, 2006.
- GGOS, The Global Geodetic Observing System: Meeting the requirements of a global society on a changing planet in 2020 (GGOS 2020 book), ed. by H.-P. Plag and M. Pearlman, submitted to Springer Verlag, ~370 pp., 2009.
- Heinkelmann, R., J. Böhm, and H. Schuh, Effects of Surface Pressure and Temperature on the VLBI Reference Frames, in *Measuring the Future – Proceedings of the Fifth IVS General Meeting*, ed. by A. Finkelstein and D. Behrend, Saint Petersburg, Nauka, ISBN 978-5-02-025332-2, pp. 188–192, 2008.
- Herring, T.A., J.L. Davis, and I.I. Shapiro, Geodesy by Radio Interferometry: The Application of Kalman Filtering to the Analysis of Very Long Baseline Interferometry Data, *Journal of Geophysical Research*, Vol. 95, No. B8, 1990.
- Himwich, E., and B. Corey, VLBI2010 Antenna Control Recommendations, *IVS Memorandum 2009-003v01*, March 12, 2009.
- Hobiger T., R. Ichikawa, Y. Koyama, and T. Kondo, Fast and accurate ray-tracing algorithms for real-time space geodetic applications using numerical weather models, *Journal of Geophysical Research*, under review, 2008a.
- Hobiger T., R. Ichikawa, T. Takasu, Y. Koyama, and T. Kondo, Ray-traced troposphere slant delays for precise point positioning, *Earth, Planets and Space*, Vol. 60, No. 5, e1–e4, 2008b.
- Hobiger T., M. Sekido, Y. Koyama, and T. Kondo, Integer phase ambiguity estimation in next-generation geodetic Very Long Baseline Interferometry, *J. Adv. Space Res.*, doi:10.1016/j.asr.2008.06.004, 2008c.
- Ichikawa, R., A. Ishii, H. Takiguchi, H. Kuboki, M. Kimura, J. Nakajima, Y. Koyama, T. Kondo, M. Machida, S. Kurihara, K. Kokada, and S. Matsuzakas, Development of a Compact VLBI System for Providing over 10-km Baseline Calibration, in *Measuring the Future – Proceedings of the Fifth IVS General Meeting*, ed. by A. Finkelstein and D. Behrend, Saint Petersburg, Nauka, ISBN 978-5-02-025332-2, pp. 400–404, 2008.
- IGS, IGS Site Guidelines, IGS Central Bureau, Jet Propulsion Laboratory/Caltech, <http://igs.cb.jpl.nasa.gov/network/guidelines/guidelines.html>, 2007.
- Imbriale, W., S. Weinreb, and H. Mani, Design of a Wideband Radio Telescope, *IEEE Aerospace Conference, Big Sky, Montana*, March 3–10, 2007, pp. 1–12, 2007.
- Jacobs, C.S., S.J. Keihm, G.E. Lanyi, C.J. Naudet, L. Riley, A.B. Tanner, Improving Astrometric VLBI by using Water Vapor Radiometry Calibrations, in *IVS 2006 General Meeting Proceedings*, ed. by D. Behrend and K. Baver, NASA/CP-2006-214140, pp. 336–340, 2006a.
- Jacobs, C.S., G.E. Lanyi, C.J. Naudet, O.J. Sovers, L.D. Zhang, P. Charlot, E.B. Fomalont, D. Gordon, C. Ma, KQ VLBI Collaboration, Extending the ICRF to Higher Radio Frequencies:

- Global Astrometric Results at 24 GHz, in IVS 2006 General Meeting Proceedings, ed. by D. Behrend and K. Baver, NASA/CP-2006-214140, p. 320, 2006b.
- Jacobs, C.S., and O.J. Sovers, Extending the ICRF above S/X-band: X/Ka-band Global Astrometric Results, in Measuring the Future – Proceedings of the Fifth IVS General Meeting, ed. by A. Finkelstein and D. Behrend, Saint Petersburg, Nauka, ISBN 978-5-02-025332-2, pp. 284–288, 2008.
- Koyama, Y., private communication, 2004.
- Koyama, Y., M. Sekido, T. Hobiger, H. Takiguchi, and T. Kondo, Developments of an Automated Data Processing System for Ultra Rapid dUT1 e-VLBI Sessions, in Measuring the Future – Proceedings of the Fifth IVS General Meeting, ed. by A. Finkelstein and D. Behrend, Saint Petersburg, Nauka, ISBN 978-5-02-025332-2, pp. 405–409, 2008.
- MacMillan, D., Simulations Studies at Goddard, IVS Memorandum 2006-015v02, Apr. 25, 2006.
- MacMillan, D., Comparisons of Observed and Simulated CONT05 Repeatabilities for Different Turbulence Cn Models, IVS Memorandum 2008-010v01, Jul. 22, 2008.
- MacMillan, D. and R. Sharma, Sensitivity of VLBI2010 Simulations to Parameterization of Input Simulated Turbulence, Clock and White Noise, IVS Memorandum 2008-011v01, Jul. 25, 2008.
- Malkin, Z., On the IVS2010 Transition Plan and Using of Old Antennas), IVS Memorandum 2007-012v01, Nov. 5, 2007.
- Malkin, Z., VLBI2010 Core Station Standard, IVS Memorandum 2008-016v01, Sep. 6, 2008a.
- Malkin, Z., VLBI2010 Towards Automated Data Analysis, IVS Memorandum 2008-017v01, Sep. 7, 2008b.
- Malkin Z. and E. Skurikhina. OCCAM/GROSS Software Used at the IAA EOP Service for processing of VLBI Observations. Transactions. IAA, vol. 12, pp. 54–67, 2005. (in Russian)
- Malkin Z., E. Skurikhina, M. Sokolskaya, G. Krasinsky, M. Vasilyev, V. Gubanov, I. Surkis, I. Kozlova, and Yu. Rusinov, IAA VLBI Analysis Center Report 2001. In: N.R.Vandenberg, K.D.Baver (Eds.), IVS 2001 Annual Report, NASA/TP-2002-210001, pp. 220–223, 2002.
- Niell, A.E., Interaction of Atmosphere Modeling and VLBI Analysis Strategy, in IVS 2006 General Meeting Proceedings, ed. by D. Behrend and K. Baver, NASA/CP-2006-214140, pp. 252–256, 2006a.
- Niell, A.E., Source Structure Simulation, IVS Memorandum 2006-017v01, August 9, 2006b.
- Niell, A.E., Source Structure Examples, IVS Memorandum 2006-018v01, August 29, 2006c.
- Niell, A.E., Simulation networks - 1, IVS Memorandum 2007-001v01, February 1, 2007.
- Niell, A.E., A. Whitney, B. Petrachenko, W. Schlüter, N. Vandenberg, H. Hase, Y. Koyama, C. Ma, H. Schuh, and G. Tuccari, VLBI2010: Current and Future Requirements for Geodetic VLBI Systems, 2005 IVS Annual Report, pp. 13–40, 2006.
- Nilsson, T., R. Haas, and G. Elgered, Simulation of atmospheric path delays using turbulence models, Proceedings of the 18th European VLBI for Geodesy and Astrometry Working Meeting, 12-13 April 2007, edited by J. Böhm, A. Pany, and H. Schuh, Geowissenschaftliche Mitteilungen, Heft Nr. 79, Schriftenreihe der Studienrichtung Vermessung und Geoinformation, Technische Universität Wien, 2007.

- Nilsson, T. and R. Haas, Modeling Tropospheric Delays with Atmospheric Turbulence Models, in *Measuring the Future – Proceedings of the Fifth IVS General Meeting*, ed. by A. Finkelstein and D. Behrend, Saint Petersburg, Nauka, ISBN 978-5-02-025332-2, pp. 361–370, 2008.
- Pany, A., J. Wresnik, and J. Böhm, Vienna VLBI2010 PPP Simulator, IVS Memorandum 2008-012v01, Aug. 14, 2008a.
- Pany, A., J. Wresnik, and J. Böhm, Investigation of the Impact of Random Error Sources on Position Repeatability using the VLBI2010 PPP Simulator, IVS Memorandum 2008-013v01, Aug. 14, 2008b.
- Pany, A., J. Wresnik, and J. Böhm, VLBI2010 analysis strategies tested with the PPP Simulator, IVS Memorandum 2008-018v01, 2008c.
- Petrachenko, B., A Monte Carlo Simulator for Geodetic VLBI, IVS Memorandum 2006-011v01, December 16, 2005.
- Petrachenko, B., Performance Comparison between Traditional S/X and X/Ka Systems and a Broadband S-Ku System, IVS Memorandum 2006-016v01, July 12, 2006.
- Petrachenko, B., A Proposed VLBI2010 Observing Scenario, IVS Memorandum 2007-007v01, August 21, 2007.
- Petrachenko, B., Performance of Broadband Delay (BBD) Sequences, IVS Memorandum 2008-005v01, June 20, 2008a.
- Petrachenko, B., VLBI2010 Antenna Slew Rate Considerations, IVS Memorandum 2008-008v01, July 7, 2008b.
- Petrachenko, B., VLBI2010 Sensitivity and Data Storage Requirements, IVS Memorandum 2008-009v01, July 15, 2008c.
- Petrachenko, B., VLBI2010 Digital Back End (DBE) Requirements, IVS Memorandum 2008-014v01, Aug. 26, 2008d.
- Petrachenko, B., VLBI2010 Frequency Considerations, IVS Memorandum 2008-015v01, Aug. 27, 2008e.
- Petrachenko, B., and M. Bérubé, VLBI2010 Source Map Alignment Simulation, IVS Memorandum, 2007-008v01, August 22, 2007.
- Petrachenko, B., J. Böhm, D. MacMillan, A. Pany, A. Searle, and J. Wresnik, VLBI2010 Antenna Slew Rate Study, in *Measuring the Future – Proceedings of the Fifth IVS General Meeting*, ed. by A. Finkelstein and D. Behrend, Saint Petersburg, Nauka, ISBN 978-5-02-025332-2, pp. 410–415, 2008.
- Petrov, L., Using source maps for scheduling and data analysis: approaches and strategies, *Proceedings of the 18th European VLBI for Geodesy and Astrometry Working Meeting*, 12-13 April 2007, edited by J. Böhm, A. Pany, and H. Schuh, *Geowissenschaftliche Mitteilungen*, Heft Nr. 79, Schriftenreihe der Studienrichtung Vermessung und Geoinformation, Technische Universität Wien, 2007.
- Rogers, A.E.E., Simulations of broadband delay measurements, Mark 5 memo #043, 2006.
- Rogers, A.E.E., Preliminary test of new “digital” phase calibrator, BBDev memo #023, 2008.

- Schuh, H., SCHED2010: Next Generation Scheduling for VLBI2010, Project P21049, FWF Austrian Science Fund, <http://www.fwf.ac.at/en/abstracts/abstract.asp?L=E&PROJ=P21049>, 2008.
- Shaffer, D.B., RFI: Effects on Bandwidth Synthesis, IVS 2000 General Meeting Proceedings, p. 402–406, Feb. 21–24, 2000.
- Tatarskii, V. I., The Effects of the Turbulent Atmosphere on Wave Propagation. Jerusalem: Israel Program for Scientific Translations, 1971.
- Treuhaf, R. N. and G. E. Lanyi, The effect of the dynamic wet troposphere on radio interferometric measurements, Radio Sci., vol. 22, no. 2, pp. 251–265, 1987.
- US SKA Consortium, 2004 Update on the Large-N/Small-D SKA Concept: Technology Development and Demonstrators, SKA Demonstrator Plans – June 2004, http://www.skatelescope.org/PDF/US_dem.pdf
- Wresnik, J. and J. Böhm, V2C Simulations at IGG Vienna, IVS Memorandum 2006-010v03, Sep. 7, 2006.
- Wresnik, J., A. Pany, and J. Böhm, Evaluation of New Cn Values for the Turbulence Model with CONT05 Real Data, IVS Memorandum 2008-004v01, Jun.19, 2008a.
- Wresnik, J., A. Pany, and J. Böhm, Impact of Turbulence Parameters on VLBI2010 Simulation Results with OCCAM Kalman Filter, IVS Memorandum 2008-007v02, Jul. 15, 2008b.

Appendices

Appendix A. Structure Constants and Wet Effective Heights.

Atmospheric turbulence causes spatial and temporal variations in the refractive index of the air. These cause fluctuations in the atmospheric delay of radio signals. According to the theory of Kolmogorov turbulence the variations in the refractive index n can be described by the structure function (e.g., Tatarskii, 1971):

$$\langle (n(\vec{r}_1, t_1) - n(\vec{r}_2, t_2))^2 \rangle = C_n^2 \|\vec{r}_1 + \vec{v}t_1 - \vec{r}_2 - \vec{v}t_2\|^{2/3} \quad (\text{A-1})$$

where \vec{r}_i is the position, t_i the time, \vec{v}_i the wind velocity vector, and C_n is the refractive index structure constant. Here it is assumed that temporal variations in the refractive index are caused by the air moving with the wind (Taylor's frozen flow hypothesis).

Using Equation (A-1), it is possible to calculate the covariance matrix C for the variations in equivalent zenith wet delays (slant wet delays divided by the wet mapping function):

$$[C]_{i,j} = \langle (l_i - l_0)(l_j - l_0) \rangle \quad (\text{A-2})$$

where l_i is the equivalent zenith wet delay of direction i at time t_i , and l_0 the initial zenith wet delay. For more details about the calculations, see [Nilsson et al. \(2007\)](#) and [Nilsson and Haas \(2008\)](#). Using a Cholesky decomposition of C (i.e., finding D so that $C=DD^T$), simulated equivalent zenith wet delays can be generated by:

$$\vec{l} = l_0 + D\vec{n} \quad (\text{A-3})$$

where \vec{n} is a vector of zero mean Gaussian distributed random numbers with variance 1.

In order to calculate the covariance matrix C we need to know the structure constant C_n and the wind velocity vector. Furthermore we need to know the initial zenith wet delay l_0 in order to simulate the atmospheric delays. The wind velocity for a site can be obtained from, for instance, numerical weather models. l_0 can be taken to be the mean zenith wet delay of the site. A simplifying assumption that C_n is constant up to an effective height H and zero above is often used (e.g., [Treuhaft and Lanyi, 1987](#)). The effective height H can be set to be the scale height of atmospheric water vapor, i.e., it can be estimated from numerical weather models. The value of C_n is however more difficult to estimate accurately.

One possible way to estimate the profile of C_n is to use high resolution radiosonde data. Methods exist which relate C_n^2 to the mean vertical potential refractive index gradient M :

$$C_n^2 = \alpha^2 FL_0^{4/3} M^2 \quad (\text{A-4})$$

where $\alpha^2=2.8$, L_0 is called the outer scale of turbulence (typically in the range 5–100 m), and F the fraction of the air which is turbulent ([d'Auria, 1993](#)). One problem with this method is that it can only be used under cloud free conditions. Another problem is that some quantities (i.e., L_0 and F) are generally not known accurately, hence their statistical distributions have to be assumed. This means that the method is only useful for determining long-time averages of the C_n profile, and that there may be errors if the wrong statistical properties are assumed.

The C_n values used in the simulations were determined using radiosonde data from two locations, Barrow, Alaska and Southern Great Plains, Oklahoma, observed in March 2004. In the determination of C_n the values $L_0=50$ m and $F=0.1$ were assumed, which are typical for these parameters ([d'Auria, 1993](#)). Since the approximation of constant C_n up to an effective height H was used in the simulations, the constant C_n value for each of the radiosonde sites was estimated as the mean C_n of the lowest 1 km of the atmosphere. These values were then interpolated/extrapolated

from the locations of the radiosonde launch sites to the locations of the VLBI sites, assuming that C_n only depends on latitude. The effective heights H were estimated from ECMWF data. The obtained values are listed below.

```

-----
% Parameters for atmospheric modeling (turbulence) for 40 VLBI2010 stations
-----
% - Cn based on model-fit to high-resolution radiosonde observations
% - mean Trop-h based on fit to ERA40 data for March 2002
% - mean Wind at 850 hPa from ERA40 data for March 2002
-----
% R.Haas and T. Nilsson, 2007-11-06
% Chalmers University of Technology, Onsala Space Observatory
-----
%ID      Station name      average Cn      mean Trop-h      mean wind at 850hPa
%          [m^(-1/3)]      [m]              speed [m/s] az [deg]
-----
BA      BADARY      0.860027e-7      1815.4943      4.7496  86.9933
BN      BAN2      2.466039e-7      1678.9426      4.0975 -32.4796
HH      HARTRAO      2.028542e-7      1851.3535      3.4897 -54.3323
HO      HOBART26      1.157924e-7      2043.1756      11.5446  74.7812
KK      KOKEE      2.297883e-7      1779.4592      5.5165 -37.5167
NY      NYALES20      0.349468e-7      1844.9730      7.4829   4.0280
TS      TSUKUB32      1.445493e-7      1911.5739      10.5455  84.3789
WZ      WETTZELL      0.938080e-7      1856.2057      7.9631  32.0023
FT      FORTLEZA      2.466039e-7      2141.9338      7.6980 -67.6056
GC      GILCREEK      0.554994e-7      1963.2784      7.5199 -59.6379
KE      KERG      0.931880e-7      2088.5080      17.8279  79.0009
KW      KWJ1      2.466039e-7      1628.8475      9.5635 -99.8577
MS      MAS1      1.906584e-7      1890.5852      7.6967   6.8017
TA      TAHITI      2.466039e-7      2077.6285      5.5753 -12.1229
TC      TIGOCONC      1.411861e-7      2175.6619      5.1014  76.2553
WF      WESTFORD      1.165242e-7      2268.7114      13.0499  65.5989
AU      AUCK      1.433560e-7      1864.0093      8.3064   1.5179
GD      Goldston      1.479926e-7      2130.5076      4.8198   8.3134
HY      HALY      1.824938e-7      1901.3589      6.2506  17.8366
MA      MALI      2.466039e-7      1877.0075      4.9969 -76.8905
KA      KATHERIN      2.466039e-7      1978.8791      9.6918 -69.3541
QA      QAQ1      0.645369e-7      1775.6118      10.0091  32.3462
RI      RIOP      2.466039e-7      2414.2041      1.2533 -96.6994
YR      YARRAGAD      1.782477e-7      1939.7270      5.7577   6.6963
DG      DGAR      2.466039e-7      2291.1460      5.9695  69.1032
IS      ISPA      1.950707e-7      1977.7792      4.4918 -43.8065
LP      LPGS      1.522734e-7      2030.8505      7.4932  28.5843
MK      MSKU      2.466039e-7      2271.7389      2.4047 -11.2676
ND      NewDelhi      1.854215e-7      1751.8718      4.7775  95.1590
PA      PALAU      2.466039e-7      2217.2973      7.6139 -75.7237
SA      SASK      0.850104e-7      1843.3937      7.9263  83.1042
ZC      ZELENCHK      1.120531e-7      1969.6235      6.2397  41.6703
BR      BRMU      1.640137e-7      2009.9043      8.4550  11.9532
IN      INEG      2.345611e-7      2241.5587      1.4226  39.2018
IQ      IQQE      2.452991e-7      2111.6343      1.7635 101.0215
KU      KUNM      2.085144e-7      1771.3422      1.7346  40.9947
MC      MCM4      0.366438e-7      2270.4486      5.6440  37.5639
OH      OHIGGINS      0.586397e-7      1869.2954      7.2638  15.7221
SV      SVETLOE      0.643233e-7      1705.4800      11.2561  68.5330
SY      SYOWA      0.485575e-7      2116.4287      9.0917 -88.3625
-----

```

Appendix B. Glossary.

ASD	Allan Standard Deviation
ATA	Allen Telescope Array
az-el	azimuth/elevation (mount)
BBC	Baseband Converter
clk	Clock value
CONT05	Continuous VLBI Campaign 2005
CRF	Celestial Reference Frame
CCW	counter-clockwise
CP	Circular Polarization
CW	clockwise
DBE	Digital Back End
DORIS	Doppler Orbitography and Radio-positioning Integrated by Satellite
DQA	Data Quality Analyzer
DSN	NASA Deep Space Network
EOP	Earth Orientation Parameters
FFT	Fast Fourier Transform
FPGA	Field Programmable Gate Array
GGAO	Goddard Geophysical and Astronomical Observatory
GGOS	Global Geodetic Observing System
GNSS	Global Navigation Satellite System
GSFC	Goddard Space Flight Center
HDD	High Density Disk
HPBW	Half-Power Beamwidth
IAG	International Association of Geodesy
IAU	International Astronomical Union
iBOB	interconnect Break-Out Board
IF	intermediate frequency
IGS	International GNSS Service
ICRF	International Celestial Reference Frame
ITRF	International Terrestrial Reference Frame
IVS	International VLBI Service for Geodesy and Astrometry
JPL	Jet Propulsion Laboratory
LNA	Low-Noise Amplifier
LO	Local Oscillator
LP	Linear Polarization
MIT	Massachusetts Institute of Technology
mfw	Mapping Function Wet
MTBF	Mean Time Between Failures
NASA	National Aeronautics and Space Administration
NRCan	Natural Resources Canada
NZ	Nyquist Zone
OTT	over-the-top (antenna mount)
PPF	Polyphase Filter
PPP	Precise Point Positioning
R&D	Research and Development
RAM	Random Access Memory
RF	Radio Frequency

RFI	Radio Frequency Interference
SKA	Square Kilometre Array
SLR	Satellite Laser Ranging
SNR	Signal-to-Noise Ratio
STD	standard (antenna mount)
TCP	Transmission Control Protocol
TRF	Terrestrial Reference Frame
UDC	Up-Down Converter
V2C	VLBI2010 Committee
VLBI	Very Long Baseline Interferometry
VSI	VLBI Standard Interface
WG3	Working Group 3
WG4	Working Group 4
wn	White Noise
WVR	Water Vapor Radiometer
zwd	Zenith Wet Delay

REPORT DOCUMENTATION PAGE

Form Approved
OMB No. 0704-0188

The public reporting burden for this collection of information is estimated to average 1 hour per response, including the time for reviewing instructions, searching existing data sources, gathering and maintaining the data needed, and completing and reviewing the collection of information. Send comments regarding this burden estimate or any other aspect of this collection of information, including suggestions for reducing this burden, to Department of Defense, Washington Headquarters Services, Directorate for Information Operations and Reports (0704-0188), 1215 Jefferson Davis Highway, Suite 1204, Arlington, VA 22202-4302. Respondents should be aware that notwithstanding any other provision of law, no person shall be subject to any penalty for failing to comply with a collection of information if it does not display a currently valid OMB control number.

PLEASE DO NOT RETURN YOUR FORM TO THE ABOVE ADDRESS.

1. REPORT DATE (DD-MM-YYYY) 22-06-2009		2. REPORT TYPE Technical Memorandum		3. DATES COVERED (From - To)	
4. TITLE AND SUBTITLE Design Aspects of the VLBI2010 System, Progress Report of the IVS VLBI2010 Committee				5a. CONTRACT NUMBER	
				5b. GRANT NUMBER	
				5c. PROGRAM ELEMENT NUMBER	
6. AUTHOR(S) B. Petrachenko, A. Niell, D. Behrend, B. Corey, J. Böhm, P. Charlot, A. Collioud, J. Gipson, R. Haas, T. Hobiger, Y. Koyama, D. MacMillan, Z. Malkin, T. Nilsson, A. Pany, G. Tuccari, A. Whitney, J. Wresnik				5d. PROJECT NUMBER	
				5e. TASK NUMBER	
				5f. WORK UNIT NUMBER	
7. PERFORMING ORGANIZATION NAME(S) AND ADDRESS(ES) Goddard Space Flight Center Greenbelt, MD 20771				8. PERFORMING ORGANIZATION REPORT NUMBER 200901964	
9. SPONSORING/MONITORING AGENCY NAME(S) AND ADDRESS(ES) National Aeronautics and Space Administration Washington, DC 20546-0001				10. SPONSORING/MONITOR'S ACRONYM(S)	
				11. SPONSORING/MONITORING REPORT NUMBER NASA/TM-2009-214180	
12. DISTRIBUTION/AVAILABILITY STATEMENT Unclassified-Unlimited, Subject Category: 46 Report available from the NASA Center for Aerospace Information, 7121 Standard Drive, Hanover, MD 21076. (301)621-0390					
13. SUPPLEMENTARY NOTES B. Petrachenko: NRCAN, Penticton, BC; A. Niell: Haystack Observatory, Westford, MA; D. Behrend: NVI, Greenbelt, MD; et al.					
14. ABSTRACT This report summarizes the progress made in developing the next generation VLBI system, dubbed the VLBI2010 system. The VLBI2010 Committee of the International VLBI Service for Geodesy and Astrometry (IVS) worked on the design aspects of the new system. The report covers Monte Carlo simulations showing the impact of the new operating modes on the final products. A section on system considerations describes the implications for the VLBI2010 system parameters by considering the new modes and system-related issues such as sensitivity, antenna slew rate, delay measurement error, RFI, frequency requirements, antenna deformation, and source structure corrections. This is followed by a description of all major subsystems and recommendations for the network, station, and antenna. Then aspects of the feed, polarization processing, calibration, digital back end, and correlator subsystems are covered. A section is dedicated to the NASA proof-of-concept demonstration. Finally, sections on operational considerations, on risks and fallback options, and on the next steps complete the report.					
15. SUBJECT TERMS Geodesy, astrometry, VLBI, very long baseline interferometry, interferometry, VLBI2010, VLBI2010 system, next generation VLBI system, VLBI2010 Committee, broadband delay, geophysics, Earth orientation, radio astronomy, geodynamics, reference frames, terrestrial reference frame, celestial reference frame, length of day, Earth system science, Earth rotation.					
16. SECURITY CLASSIFICATION OF:			17. LIMITATION OF ABSTRACT	18. NUMBER OF PAGES	19b. NAME OF RESPONSIBLE PERSON
a. REPORT	b. ABSTRACT	c. THIS PAGE			Dirk Behrend
Unclassified	Unclassified	Unclassified	Unclassified	58	19b. TELEPHONE NUMBER (Include area code) (301) 614-5939

