

NASA/TM-2009-215929



Tensile Properties and Microstructure of Inconel 718 Fabricated with Electron Beam Freeform Fabrication (EBF³)

R. Keith Bird
NASA Langley Research Center, Hampton, Virginia

Joshua Hibberd
Old Dominion University, Norfolk, Virginia

NASA STI Program . . . in Profile

Since its founding, NASA has been dedicated to the advancement of aeronautics and space science. The NASA scientific and technical information (STI) program plays a key part in helping NASA maintain this important role.

The NASA STI program operates under the auspices of the Agency Chief Information Officer. It collects, organizes, provides for archiving, and disseminates NASA's STI. The NASA STI program provides access to the NASA Aeronautics and Space Database and its public interface, the NASA Technical Report Server, thus providing one of the largest collections of aeronautical and space science STI in the world. Results are published in both non-NASA channels and by NASA in the NASA STI Report Series, which includes the following report types:

- **TECHNICAL PUBLICATION.** Reports of completed research or a major significant phase of research that present the results of NASA programs and include extensive data or theoretical analysis. Includes compilations of significant scientific and technical data and information deemed to be of continuing reference value. NASA counterpart of peer-reviewed formal professional papers, but having less stringent limitations on manuscript length and extent of graphic presentations.
- **TECHNICAL MEMORANDUM.** Scientific and technical findings that are preliminary or of specialized interest, e.g., quick release reports, working papers, and bibliographies that contain minimal annotation. Does not contain extensive analysis.
- **CONTRACTOR REPORT.** Scientific and technical findings by NASA-sponsored contractors and grantees.
- **CONFERENCE PUBLICATION.** Collected papers from scientific and technical conferences, symposia, seminars, or other meetings sponsored or co-sponsored by NASA.
- **SPECIAL PUBLICATION.** Scientific, technical, or historical information from NASA programs, projects, and missions, often concerned with subjects having substantial public interest.
- **TECHNICAL TRANSLATION.** English-language translations of foreign scientific and technical material pertinent to NASA's mission.

Specialized services also include creating custom thesauri, building customized databases, and organizing and publishing research results.

For more information about the NASA STI program, see the following:

- Access the NASA STI program home page at <http://www.sti.nasa.gov>
- E-mail your question via the Internet to help@sti.nasa.gov
- Fax your question to the NASA STI Help Desk at 443-757-5803
- Phone the NASA STI Help Desk at 443-757-5802
- Write to:
NASA STI Help Desk
NASA Center for AeroSpace Information
7115 Standard Drive
Hanover, MD 21076-1320

NASA/TM-2009-215929



Tensile Properties and Microstructure of Inconel 718 Fabricated with Electron Beam Freeform Fabrication (EBF³)

R. Keith Bird
NASA Langley Research Center, Hampton, Virginia

Joshua Hibberd
Old Dominion University, Norfolk, Virginia

National Aeronautics and
Space Administration

Langley Research Center
Hampton, Virginia 23681-2199

September 2009

Trade names and trademarks are used in this report for identification only. Their usage does not constitute an official endorsement, either expressed or implied, by the National Aeronautics and Space Administration.

Available from:

NASA Center for AeroSpace Information
7115 Standard Drive
Hanover, MD 21076-1320
443-757-5802

Abstract

Electron beam freeform fabrication (EBF³) direct metal deposition processing was used to fabricate two Inconel 718 single-bead-width wall builds and one multiple-bead-width block build. Specimens were machined to evaluate microstructure and room temperature tensile properties. The tensile strength and yield strength of the as-deposited material from the wall and block builds were greater than those for conventional Inconel 718 castings but were less than those for conventional cold-rolled sheet. Ductility levels for the EBF³ material were similar to those for conventionally-processed sheet and castings. An unexpected result was that the modulus of the EBF³-deposited Inconel 718 was significantly lower than that of the conventional material. This low modulus may be associated with a preferred crystallographic orientation resultant from the deposition and rapid solidification process. A heat treatment with a high solution treatment temperature resulted in a recrystallized microstructure and an increased modulus. However, the modulus was not increased to the level that is expected for Inconel 718.

Introduction

Over the past several years NASA Langley Research Center (LaRC) has been developing Electron Beam Freeform Fabrication (EBF³) for the manufacture of near-net-shape and net-shape metallic components (ref. 1, 2). EBF³ offers the potential for efficient streamlined manufacturing of intricate components due to its ability to directly deposit material to only the regions where it is needed. A wide variety of markets is interested in this direct deposition technology which can improve the materials usage efficiency by eliminating the need for machining large quantities of material from wrought blocks and forgings or the fabrication of highly-detailed molds for castings.

Utilization of the EBF³ process for fabrication of Inconel 718 components for high-temperature structural applications is being investigated. Inconel 718 is a widely used superalloy with good weldability (ref. 3), which makes it a good candidate for the EBF³ process. One step in this evaluation process is to determine the mechanical properties of EBF³ deposits and the ability to tailor these properties to specific applications. Two different Inconel 718 EBF³ deposition product forms were fabricated for evaluation of microstructure and room temperature tensile properties. Thin walls were fabricated such that the wall thickness comprised the width of one EBF³ deposit bead. Successive layers were deposited upon each other to fabricate the wall builds. In addition, a bulk deposit was fabricated by making multiple layers of several side-by-side EBF³ deposition passes.

Electron Beam Deposition

Figure 1 shows a photograph of the primary components of the EBF³ system at NASA LaRC used for this investigation. The system uses a high-power electron beam gun in a vacuum environment. The feedstock wire is fed from a spool through the wire feed mechanism. The gun and wire feed are mounted onto a gantry with the capability of translating back and forth along one axis, up and down along the vertical axis, and tilting. The substrate is supported on a table that travels in the transverse direction and has the capability to rotate and tilt. The system is housed within a vacuum chamber with approximate dimensions of 9 ft by 7 ft by 9 ft.

The EBF³ system can be operated manually or via computer code to control the electron beam, wire feed, and translation/rotation parameters to build the desired geometric shapes. During operation, the tip of the wire feed nozzle is brought into close proximity to the substrate. At any given instant the electron beam forms a small molten pool in the substrate. The wire is fed into the beam and the molten pool, thus depositing material at that location. As the electron beam moves away due to the substrate/gun translation the molten pool rapidly solidifies. Detailed discussions of the EBF³ process and this particular system can be found in references 1 and 2.

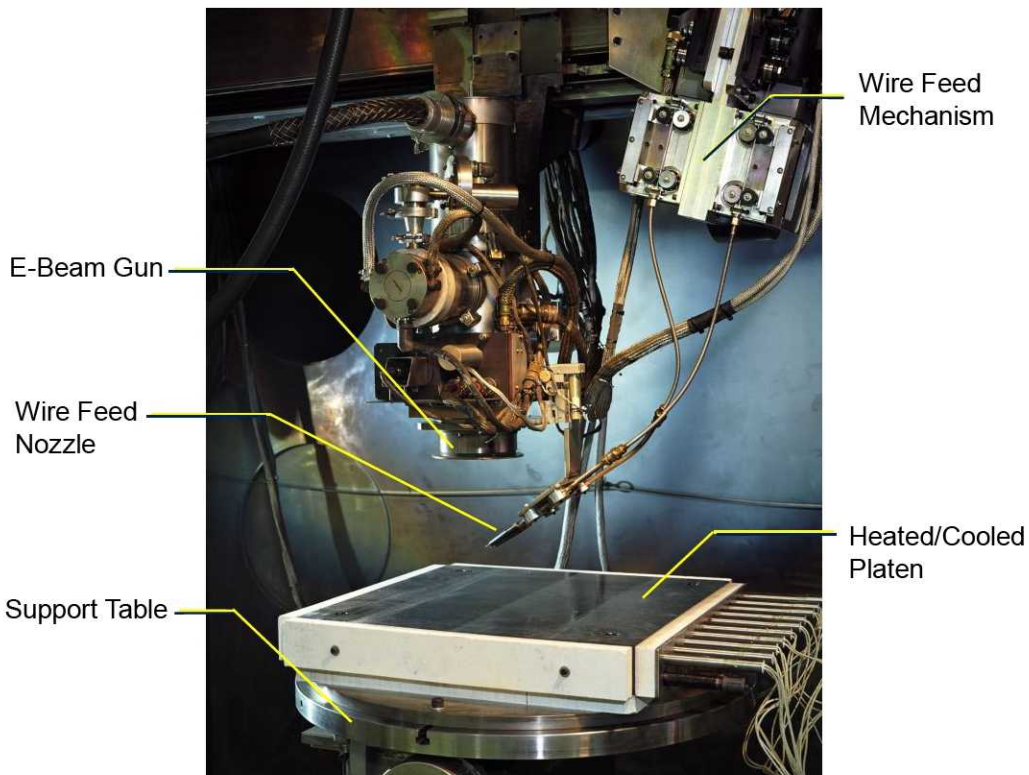

Figure 1. Electron beam freeform fabrication system.

Materials

The base plates and the wires used for the EBF³ wall and bulk block builds were Inconel 718 alloy with nominal composition, in weight percent, of Ni - 19 Cr - 18 Fe - 5.1 (Nb + Ta) - 3 Mo - 0.9 Ti - 0.5 Al (ref. 3). For the wall builds, the base plate was 6 inches by 4 inches by 0.25 inch thick. The wire diameter was 0.045 inch. The block build used a base plate with dimensions of 12 inches square by 0.125 inch thick and a wire diameter of 0.093 inch.

Experimental Procedures

Electron-Beam Freeform Fabrication (EBF³) Process

The base plate was clamped at the four corners to the EBF³ system support table. (The heated/cooled platen shown in Figure 1 was not used for these experiments.) The system was evacuated to the 10⁻⁶ torr range. Parameters for electron beam gun power and deposition rates were selected based on previous work. The electron beam gun was used to preheat the base plate and remove surface oxides in the vicinity of the wall and block builds prior to deposition.

Two walls were fabricated on the same base plate (see Figure 2). The target dimensions of the walls were 5 inches long with height of 2 inches. The wall width was approximately 0.125 inch, which was the width of a single deposit bead using the 0.045-inch diameter wire. The first wall was fabricated with a deposition travel speed of 75 in/min. The second wall was fabricated with a 50-in/min deposition travel speed. During the wall build process, four single-pass beads were deposited successively on top of each other after which the system was allowed to cool for two minutes. This process was repeated until a wall height of nominally two inches was attained. Approximately 50 layers were required to complete each wall.

The target dimensions for the block build were 5 inches long by 1 inch wide with a height of 1 inch (see Figure 3). Preliminary EBF³ deposition studies indicated that the width of a single deposit was approximately 0.180 inch (twice the 0.090-inch wire diameter). To achieve a 1-inch wide block, eight deposits were made side-by-side with a 0.150-inch center-to-center spacing. This spacing produced a 0.030-inch overlap between adjacent deposits to fully fill the volume and avoid porosity. A total of 18 layers were required to build the 1-inch tall block. Each layer was built from the outside towards the center. The left edge was deposited followed by the right edge. Deposits were then made adjacent to the outermost deposits. This process was continued until the two innermost of the 8 deposits were completed for that layer. The block was allowed to cool for approximately 1 minute after each layer was deposited.

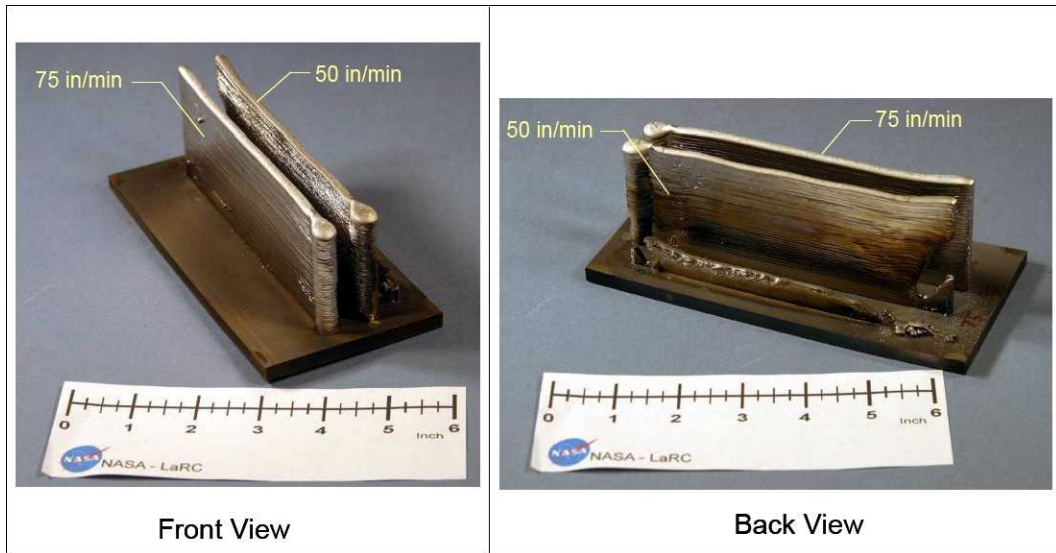

Figure 2. Inconel 718 wall builds.

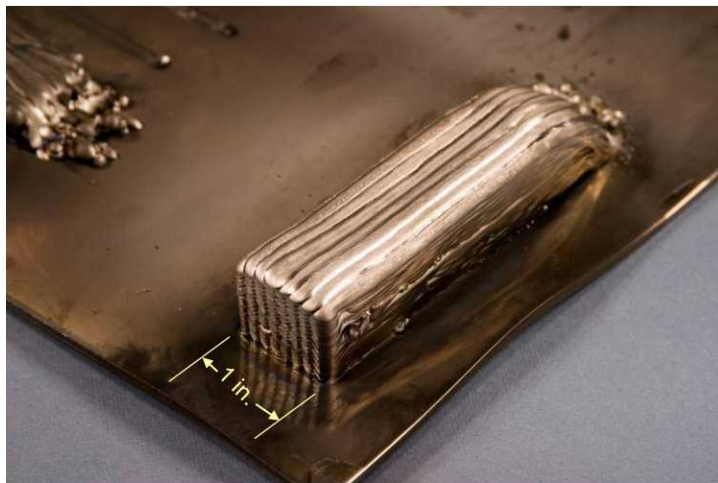

Figure 3. Inconel 718 block build.

Tensile Specimens

Tensile specimens were machined from the two wall builds as shown in Figure 4. The specimens were oriented such that the specimen length was parallel to the wall length (deposition direction) and the specimen width was parallel to the wall height direction. The walls were cut from the base plate and the wall faces were machined to produce flat parallel surfaces. Four tensile specimens were machined from each wall with specimen #1 being located near the base plate and specimen #4 being located near the top of the wall.

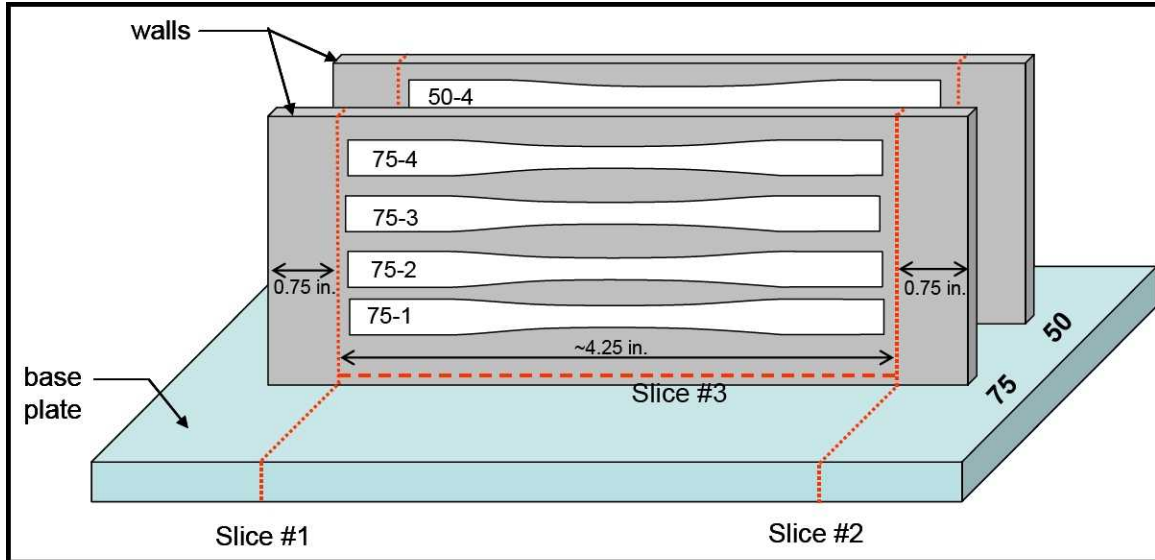

Figure 4. Tensile specimen machining diagram for wall builds.

The EBF³-deposited block was cut into lengthwise through-the-thickness slices (see the slicing information in Figure 5 and Figure 6). One tensile specimen was machined from the top portion and one from the bottom portion of each slice in order to evaluate differences in properties through the height of the block (see Figure 7). The specimen length was parallel to deposition direction (block length) and the specimen width was parallel to the block height. A total of 10 specimens were machined: 5 from the top and 5 from the bottom portions of the block. Tensile specimens from both of the wall builds and the block build were machined in accordance with ASTM specification E8 (ref. 4), as depicted in Figure 8.

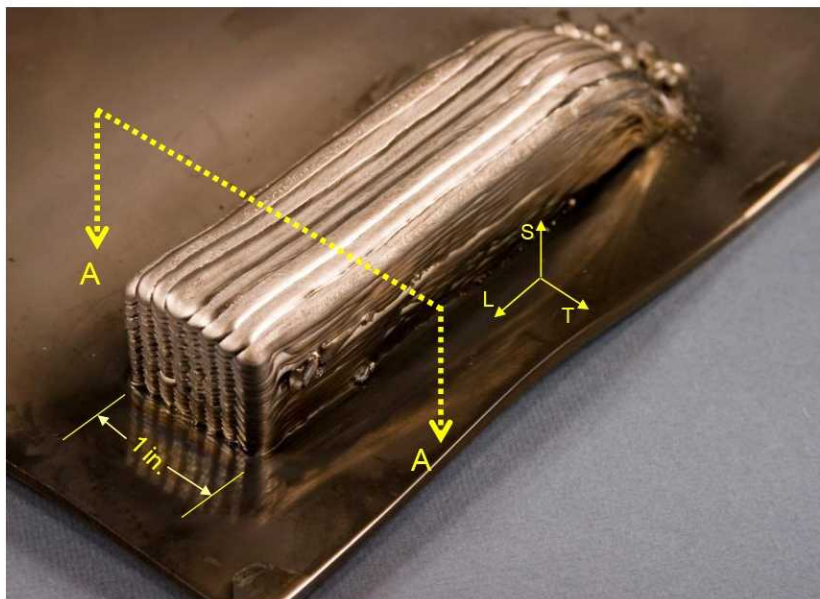

Figure 5. Block build Section A-A for reference in tensile specimen machining.

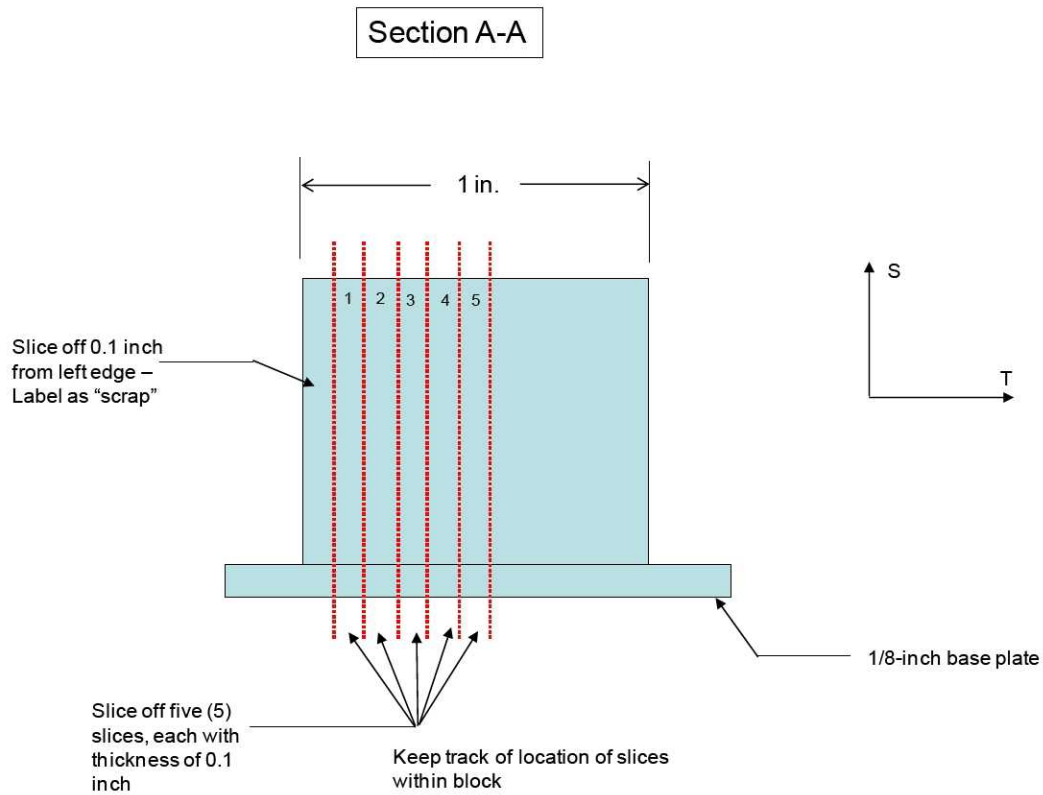

Figure 6. Slicing diagram of block build cross section (Section A-A) for tensile specimens. (Deposition direction is perpendicular to plane of page.)

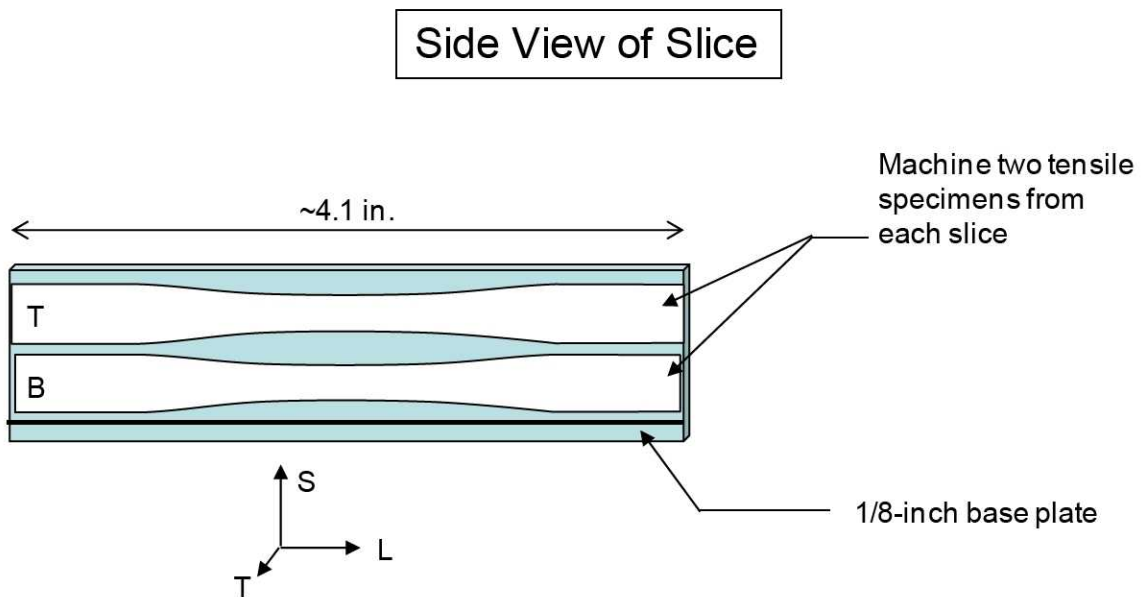

Figure 7. Tensile specimen locations within block build slices. (Deposition direction is left-to-right.)

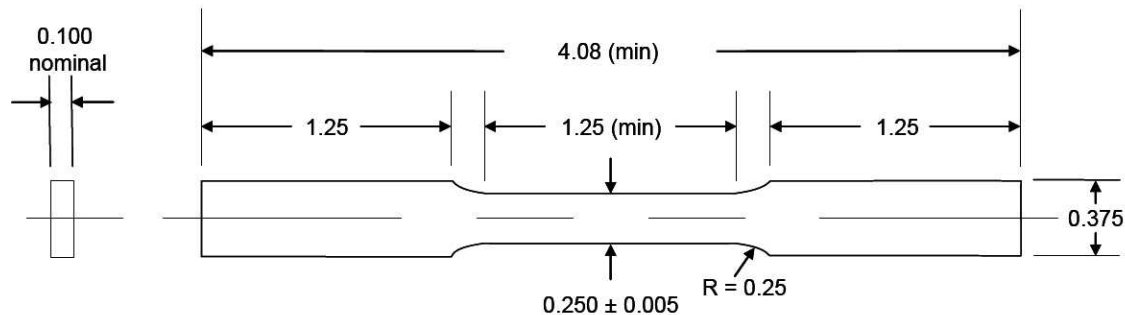

Figure 8. ASTM E8 standard subsized tensile specimen (ref. 4). All dimensions are in inches with tolerance of ± 0.010 , unless noted.

Heat Treatment

Some of the specimens machined from the block build were heat treated to determine the effect of post-EBF³ thermal processing on the properties and microstructure. Table 1 shows the two heat treatment conditions used. None of the specimens machined from the wall builds were heat treated.

Two specimens from the top and two from the bottom portions of the block were kept in the as-deposited condition. One specimen each from the top and bottom portions of the block were processed with heat treatment HT1 and one specimen each from the top and bottom portions of the block were processed with HT2. HT1 is a typical heat treatment for wrought Inconel 718 product forms and is used to solutionize and precipitate the γ' and γ'' strengthening phases (ref. 3). HT2 is a variant of the heat treatment for Inconel 718 castings documented in reference 3. Since this reference heat treatment was designed for large castings, the solution anneal time for the small EBF³ specimens was reduced from 50 hours to 4 hours. This heat treatment has the goal of solutionizing the brittle Laves phase that forms during casting and homogenizing the dendritic microstructure (ref. 3). Following heat treatment, the specimens were lightly polished to remove the surface oxide that formed.

Table 1. Heat treatments for tensile specimens machined from the Inconel 718 EBF3 block build.

HT1	<ul style="list-style-type: none"> • 1750°F for 1 hr; air cool to RT • 1325°F for 8 hrs; furnace cool to 1150°F • 1150°F for 8 hrs; air cool to RT
HT2	<ul style="list-style-type: none"> • 2175°F for 4 hrs; air cool to RT • 1325°F for 8 hrs; furnace cool to 1150°F • 1150°F for 8 hrs; air cool to RT

Precision modulus test procedures

Precision modulus tests were conducted on the specimens in the as-deposited condition in accordance with ASTM specification E111 (ref. 5). Strain was measured using back-to-back extensometers with 1-inch gage length. Each specimen was loaded to a strain level of 0.1% and unloaded. This process was repeated a total of three times. The precision modulus (E_{prec}) was calculated by taking a linear regression of the stress-strain data from the loading portion of the test.

Tensile test procedures

Tensile tests were conducted on the specimens in the as-deposited and heat treated conditions in accordance with ASTM specification E8 (ref. 4). Strain was measured using back-to-back extensometers with 1-inch gage length and a maximum extension range of 0.5 inch (50%). The specimens were loaded at a displacement rate of 0.010 in/min until a strain of 2% was attained; then the displacement rate was increased to 0.050 in/min until specimen failure. Ultimate tensile strength (UTS), 0.2%-offset yield strength (YS), total strain to failure (e_{tot}) and ductility in terms of plastic strain to failure (e_{p}) were calculated from the stress-strain data. Modulus (E) was calculated using a linear regression of the stress-strain data over the strain range of 0 to 0.2%.

Microstructural Analysis

Microstructures were analyzed using optical microscopy. Composition of the wall and block builds and the wire feed stock was measured using direct current plasma emission spectroscopy.

Results and Discussion

Chemical Composition

Table 2 shows the chemical composition measured for the wall build fabricated with deposition travel speed of 50 in/min and the block build. The compositions measured for the 0.045-inch diameter wire used to fabricate the wall and the 0.093-inch diameter wire used to build the block are also tabulated. For comparison, the nominal composition for Inconel 718 from reference 3 is shown.

The compositions of the feed-stock wires match the nominal composition. The compositions of the final EBF³ products (wall and block) also match the nominal composition of Inconel 718 and the compositions of the respective feed-stock wires. Thus, none of the Inconel 718 alloy elements were volatilized to any significant degree during the e-beam fabrication process.

Table 2. Composition of Inconel 718 wall and block builds and feed wire (nominal composition is from reference 3).

Element	Composition (wt %)				
	Nominal	0.045-in wire	wall build	0.093-in wire	block build
Ni	bal.	53.4	53.4	54.08	52.8
Cr	19	18.9	18.0	18.02	18.5
Fe	18	17.7	17.8	17.93	18.3
Mo	3	3.1	3.2	3.17	3.07
Nb	---	5.1	5.7	4.93	5.12
Ta	---	0.0	0.0	0.002	0.002
Nb + Ta	5.1	5.1	5.7	4.93	5.12
Ti	0.9	0.9	1.1	0.89	1.06
Al	0.5	0.6	0.6	0.45	0.52

Tensile Properties

Table 3 shows the tensile properties measured for the wall builds as well as reference properties for conventionally-processed Inconel 718 (rolled sheet and castings). The tensile properties of the two walls fabricated at different deposition travel rates were almost identical, within the scatter range. The UTS and YS results showed significant variation from specimen to specimen. The average UTS and YS values of the wall builds were about 15-20% greater than those for as-cast Inconel 718 and about 35-50% less than those for rolled Inconel 718 sheet. This result is expected since the EBF³ process is essentially a rapid-solidification casting process and does not include mechanical deformation processing associated with rolled product. The specimens machined from the portion of the wall closest to the base plate had the lowest strength, with the strength tending to increase as the specimen location moved away from the base plate (refer to Figure 4 for specimen locations within the wall build). The average ductility (e_p) values for the wall builds were similar to the as-cast material ductility and were about 10% greater than the ductility reported for rolled sheet. An unexpected result was that the modulus (E) for the wall builds was significantly less (about 20%) than that of conventionally-processed Inconel 718.

Table 3. Tensile properties of Inconel 718 EBF³ wall builds

Deposition travel rate	Spec. No.	UTS (ksi)	YS (ksi)	E (Msi)	e_{tot} (%)	e_p (%)
50 in/min	50-1 (a)	119.3	82.1	25.1	17.5	17.1
	50-2	132.3	86.0	22.8	29.6	29.1
	50-3 (a)	139.5	85.5	21.9	22.4	21.8
	50-4	138.0	83.0	22.9	22.4	21.8
	avg	132.3	84.2	23.2	23.0	22.4
75 in/min	75-1	124.7	75.3	23.5	37.1	36.6
	75-2	131.6	81.9	20.5	26.2	25.6
	75-3	134.2	90.7	22.5	11.5	10.9
	75-4	141.0	90.6	24.7	18.2	17.7
	avg	132.9	84.6	22.8	23.3	22.7
Ref. Data (b)	rolled sheet (0.125-in thick)	203.1	175.0	29.4	---	20.8
Ref. Data (c)	as-cast	114.0	70.8	----	----	22.0

(a) Specimen failed outside gage length.

(b) Report: AFWAL-TR-85-4128 (ref. 6)

(c) Aerospace Struct. Metals HB; code 4103; Table 3.2.1.14 (ref. 3)

The tensile properties measured for the 1-inch wide block build in the as-deposited condition and in two different heat treated conditions are shown in Table 4. Specimens labeled with “B” were machined from the bottom portion of the EBF³ deposit and specimens labeled with “T” were machined from the top portion. The UTS and YS of the as-deposited specimens were greater than those measured for the wall builds. Also, the UTS and YS of the specimens machined from the bottom portion of the block were greater than those for the specimens from the top portion. This trend is the reverse of the trend observed in the wall builds. As was the case with the wall builds, the modulus of the EBF³ as-deposited specimens was significantly lower than that for conventionally-processed Inconel 718. Since the wall builds and the block build had low modulus values and there were no compositional changes associated with EBF³ deposition of Inconel 718, the deposition process may have produced a low-modulus preferred crystallographic orientation along the direction of deposition.

The heat treatments resulted in more uniform properties with respect to the top and bottom locations indicating that they successfully homogenized the properties. The higher-temperature heat treatment (HT2) resulted in a greater modulus compared to the as-deposited condition, but still lower than for conventional Inconel 718.

Table 4. Tensile properties of Inconel 718 EBF³ block build.

Condition	Location within block	Spec. No.	UTS (ksi)	YS (ksi)	E (Msi)	e _{tot} (%)	e _p (%)	E _{prec} (Msi)
As-Deposited	top	T1	146.6	91.6	22.9	31.1	30.5	23.5
		T2	139.9	86.1	23.1	31.5	31.0	23.4
		ave	143.3	88.9	23.0	31.3	30.8	23.4
	bottom	B1	153.3	103.9	24.3	21.0	20.4	24.6
		B2	152.8	104.5	24.6	20.5	19.8	24.2
		ave	153.1	104.2	24.4	20.8	20.1	24.4
HT 1	top	T3	179.5	137.1	23.9	22.8	22.1	---
	bottom	B3	180.8	137.6	24.3	24.2	23.5	---
HT 2	top	T4	164.2	136.6	25.8	21.8	21.2	---
	bottom	B4	163.0	133.8	25.7	22.6	21.9	---

Microstructural Analysis

Figure 9 shows low and high magnification views of the microstructure of the wall build that was fabricated with a deposition travel rate of 50 in/min. The wall fabricated with a rate of 75 in/min had similar microstructural characteristics. The layered nature of the microstructure is apparent. The microstructure consisted of a fine dendritic structure resultant from the rapidly solidified melt pool. These dendrites extended in the direction of the wall height across multiple deposition layers. In addition to the long dendrite colonies, examination at higher magnification shows that new dendrite colonies formed at each boundary between adjacent deposition layers.

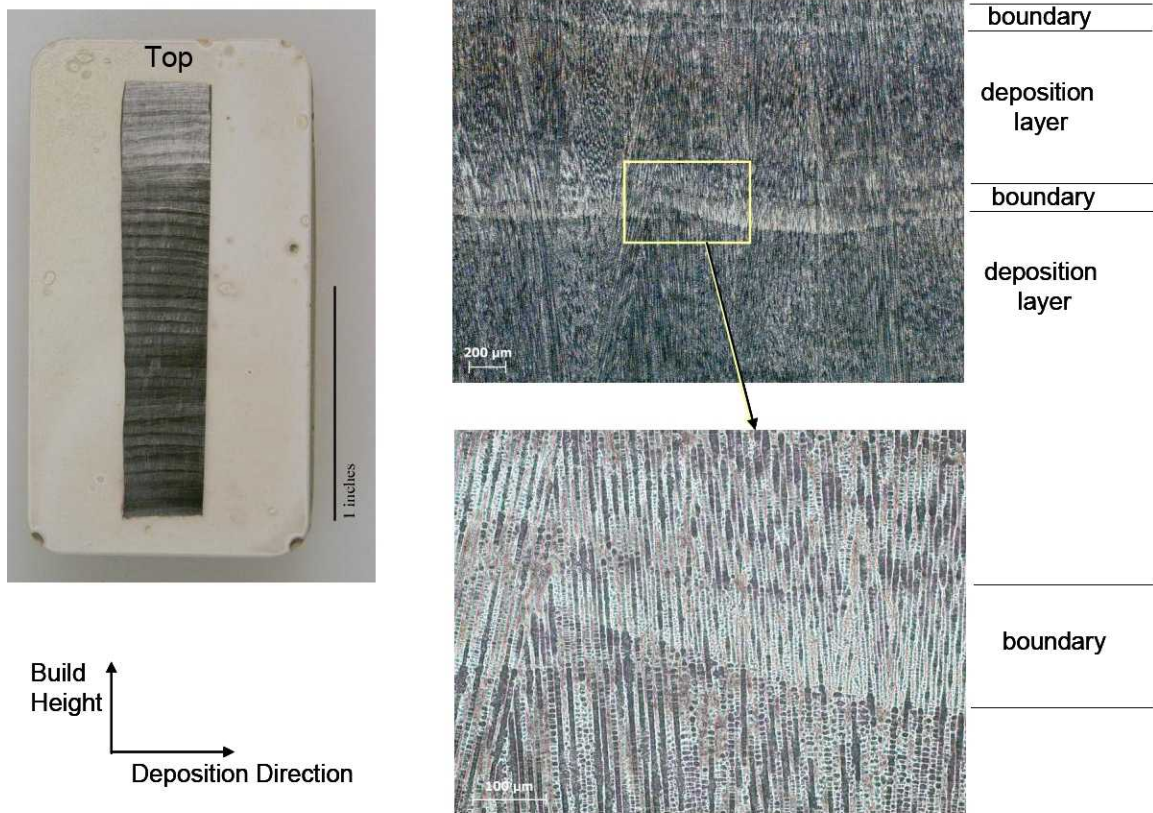

Figure 9. Microstructure of wall build fabricated with deposition rate of 50 in/min.

The microstructures of the Inconel 718 block build material in the as-deposited and heat treated conditions are shown in Figure 10. The microstructure of the as-deposited material is very similar to that of the wall build. Heat treatment HT1 did not have a major effect on the appearance of the microstructure. However, the high solution treatment temperature used with heat treatment HT2 resulted in recrystallization and elimination of the original deposition layer boundaries. The microstructure consisted of a bimodal distribution of large and small grains. Based on the modulus data associated with the HT2 condition, this heat treatment reoriented the microstructure to allow a modest increase in modulus along the deposition direction.

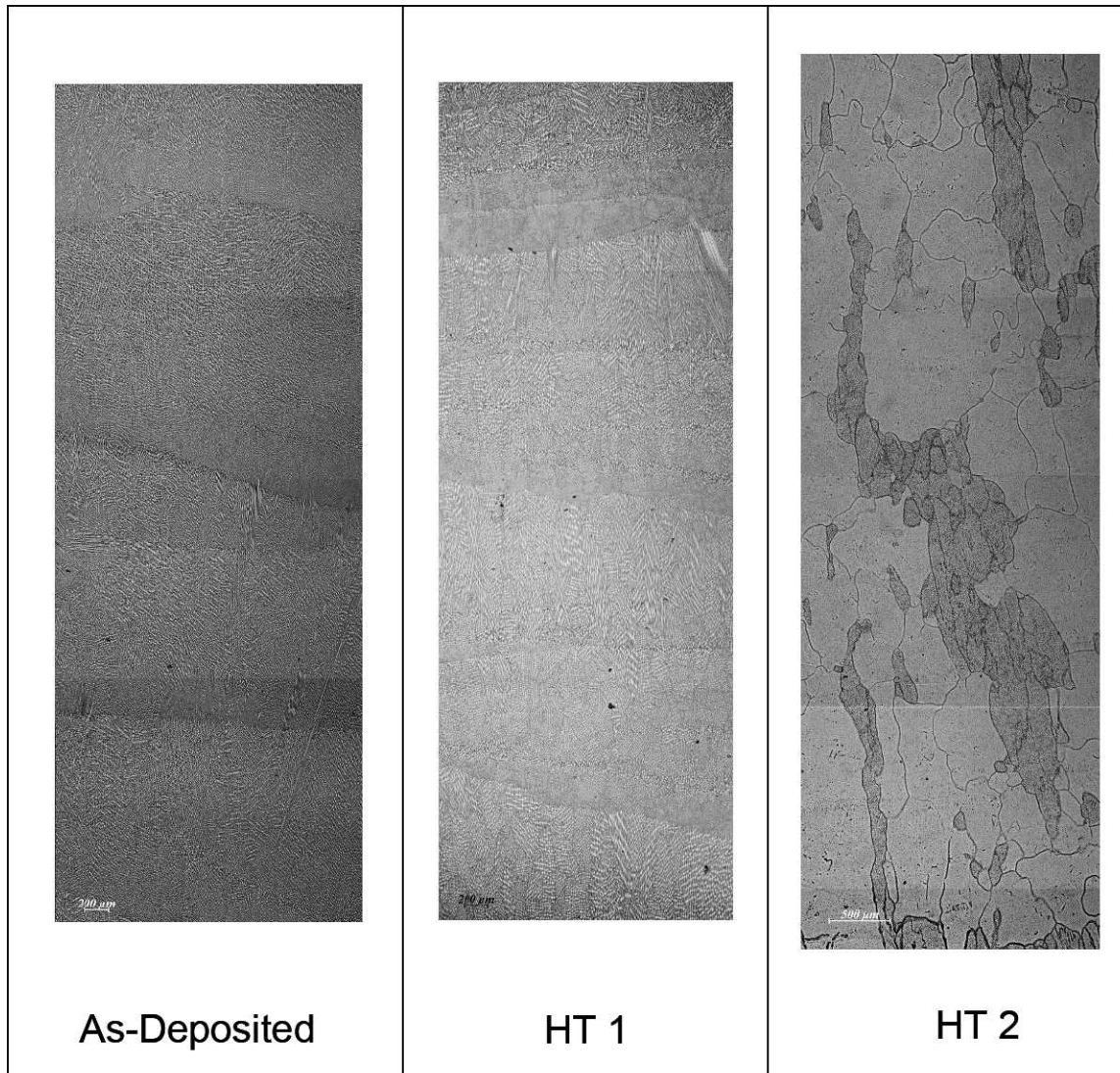

Figure 10. Microstructure of block build in as-deposited and heat treated conditions. (Deposition direction is left-to-right; wall height is vertical.)

Concluding Remarks

Electron beam freeform fabrication (EBF³) direct metal deposition processing was used to fabricate two Inconel 718 wall builds and one block build. Specimens were machined from the builds to evaluate microstructure and room temperature tensile properties. The properties were measured only in the direction of deposition due to the dimensions of the wall and block builds.

The tensile strength and yield strength of the as-deposited material from the wall and block builds were greater than those for conventional Inconel 718 castings. Since the EBF³-deposited material had no cold work, the strength levels were lower than those for conventional cold-rolled sheet. Ductility levels for the EBF³ material were similar to those for conventionally-processed sheet and castings. An unexpected result was that the modulus of the EBF³ material was

significantly lower than that of the conventional material. This low modulus may be associated with a preferred crystallographic orientation resultant from the deposition and rapid solidification process. A heat treatment with a high solution treatment temperature resulted in a recrystallized microstructure and an improved modulus. However, the modulus was not increased to the level that is expected for Inconel 718. Analysis of the crystallographic structure of the EBF³ Inconel 718 material will be required to better understand this phenomenon.

A more detailed microstructural analysis of EBF³-deposited Inconel 718 will be conducted in the future to better understand the relationship between the deposition process and the properties, especially the low modulus values. In addition, larger-scale Inconel 718 EBF³ builds will be fabricated to allow measurement of properties in directions other than just parallel to the deposition direction.

References

1. Taminger, Karen and Hafley, Robert. "Electron Beam Freeform Fabrication: A Rapid Metal Deposition Process"; Proceedings of the 3rd Annual Automotive Composites Conference, September 9-10, 2003, Troy, MI. Society of Plastics Engineers (2003).
2. Taminger, Karen and Hafley, Robert. "Electron Beam Freeform Fabrication (EBF³) for Cost Effective Near-Net Shape Manufacturing"; NASA Technical Memorandum TM-2006-214284, March 2006.
3. Aerospace Structural Metals Handbook – Volume 6, Code 4103. Brown, Mindlin, and Ho, eds. 39th Edition, CINDAS/USAF CRDA Handbook operation, Purdue University, West Lafayette, Indiana, 2005.
4. "Standard Test Methods for Tension Testing of Metallic Materials." Annual Book of ASTM Standards. Vol. 03.01. Designation E8-04 American Society for Testing and Materials, West Conshohocken, PA 2004.
5. "Standard Test Methods for Young's Modulus, Tangent Modulus and Chord Modulus." Annual Book of ASTM Standards. Vol. 03.01. Designation E111-97 American Society for Testing and Materials, West Conshohocken, PA 2004.
6. Ruff, Paul E. "Effect of Manufacturing Processes on Structural Allowables – Phase I." Air Force Wright Aeronautical Laboratories Technical Report No. AFWAL-TR-85-4128. January 1986.

Acknowledgement

Joshua Hibberd contributed to this work as a Governor's School student while attending Princess Anne High School in Virginia Beach, Virginia, during the summer of 2006.

REPORT DOCUMENTATION PAGE

*Form Approved
OMB No. 0704-0188*

The public reporting burden for this collection of information is estimated to average 1 hour per response, including the time for reviewing instructions, searching existing data sources, gathering and maintaining the data needed, and completing and reviewing the collection of information. Send comments regarding this burden estimate or any other aspect of this collection of information, including suggestions for reducing this burden, to Department of Defense, Washington Headquarters Services, Directorate for Information Operations and Reports (0704-0188), 1215 Jefferson Davis Highway, Suite 1204, Arlington, VA 22202-4302. Respondents should be aware that notwithstanding any other provision of law, no person shall be subject to any penalty for failing to comply with a collection of information if it does not display a currently valid OMB control number.
PLEASE DO NOT RETURN YOUR FORM TO THE ABOVE ADDRESS.

1. REPORT DATE (DD-MM-YYYY) 01-09-2009		2. REPORT TYPE Technical Memorandum		3. DATES COVERED (From - To)	
4. TITLE AND SUBTITLE Tensile Properties and Microstructure of Inconel 718 Fabricated with Electron Beam Freeform Fabrication (EBF3)				5a. CONTRACT NUMBER	
				5b. GRANT NUMBER	
				5c. PROGRAM ELEMENT NUMBER	
6. AUTHOR(S) Bird, R. Keith; Hibberd, Joshua				5d. PROJECT NUMBER	
				5e. TASK NUMBER	
				5f. WORK UNIT NUMBER	
7. PERFORMING ORGANIZATION NAME(S) AND ADDRESS(ES) NASA Langley Research Center Hampton, VA 23681-2199				8. PERFORMING ORGANIZATION REPORT NUMBER L-19731	
9. SPONSORING/MONITORING AGENCY NAME(S) AND ADDRESS(ES) National Aeronautics and Space Administration Washington, DC 20546-0001				10. SPONSOR/MONITOR'S ACRONYM(S) NASA	
				11. SPONSOR/MONITOR'S REPORT NUMBER(S) NASA/TM-2009-215929	
12. DISTRIBUTION/AVAILABILITY STATEMENT Unclassified - Unlimited Subject Category 26 Availability: NASA CASI (443) 757-5802					
13. SUPPLEMENTARY NOTES					
14. ABSTRACT Electron beam freeform fabrication (EBF3) direct metal deposition processing was used to fabricate two Inconel 718 single-bead-width wall builds and one multiple-bead-width block build. Specimens were machined to evaluate microstructure and room temperature tensile properties. The tensile strength and yield strength of the as-deposited material from the wall and block builds were greater than those for conventional Inconel 718 castings but were less than those for conventional cold-rolled sheet. Ductility levels for the EBF3 material were similar to those for conventionally-processed sheet and castings. An unexpected result was that the modulus of the EBF3-deposited Inconel 718 was significantly lower than that of the conventional material. This low modulus may be associated with a preferred crystallographic orientation resultant from the deposition and rapid solidification process. A heat treatment with a high solution treatment temperature resulted in a recrystallized microstructure and an increased modulus. However, the modulus was not increased to the level that is expected for Inconel 718.					
15. SUBJECT TERMS Inconel 718; Direct metal deposition; Electron beam freeform fabrication; Mechanical properties					
16. SECURITY CLASSIFICATION OF:			17. LIMITATION OF ABSTRACT	18. NUMBER OF PAGES	19a. NAME OF RESPONSIBLE PERSON
a. REPORT	b. ABSTRACT	c. THIS PAGE			STI Help Desk (email: help@sti.nasa.gov)
U	U	U	UU	19	19b. TELEPHONE NUMBER (Include area code) (443) 757-5802