

NASA/TP-2009-214769



A Summary of NASA and USAF Hypergolic Propellant Related Spills and Fires

B. M. Nufer
Kennedy Space Center, Florida

EAR 99 -- NO LICENSE REQUIRED

The information contained in the document is technical in content, but not technical data as defined by the International Traffic in Arms Regulations (ITAR) or the Export Administration Regulations (EAR), and therefore is EAR 99 NLR, no export license required, suitable for public release. [General Prohibition Six (Embargo) applies to all items subject to the EAR, i.e. items on the CCL and within EAR 99 NLR. You may not make an export or re-export contrary to the provisions of part 746 (Embargos and Other Special Controls) of the EAR and 22 CFR part 126.1 of the ITAR].

June 2009

NASA STI Program...in Profile

Since its founding, NASA has been dedicated to the advancement of aeronautics and space science. The NASA Scientific and Technical Information (STI) program plays a key part in helping NASA maintain this important role.

The NASA STI program operates under the auspices of the Agency Chief Information Officer. It collects, organizes, provides for archiving, and disseminates NASA's STI. The NASA STI program provides access to the NASA Aeronautics and Space Database and its public interface, the NASA Technical Report Server, thus providing one of the largest collections of aeronautical and space science STI in the world. Results are published in both non-NASA channels and by NASA in the NASA STI Report Series, which includes the following report types:

- **TECHNICAL PUBLICATION.** Reports of completed research or a major significant phase of research that present the results of NASA programs and include extensive data or theoretical analysis. Includes compilations of significant scientific and technical data and information deemed to be of continuing reference value. NASA counterpart of peer-reviewed formal professional papers, but having less stringent limitations on manuscript length and extent of graphic presentations.
- **TECHNICAL MEMORANDUM.** Scientific and technical findings that are preliminary or of specialized interest, e.g., quick release reports, working papers, and bibliographies that contain minimal annotations. Does not contain extensive analysis.
- **CONTRACTOR REPORT.** Scientific and technical findings by NASA-sponsored contractors and grantees.

- **CONFERENCE PUBLICATION.** Collected papers from scientific and technical conferences, symposia, seminars, or other meetings sponsored or co-sponsored by NASA.
- **SPECIAL PUBLICATIONS.** Scientific, technical, or historical information from NASA programs, projects, and missions, often concerned with subjects having substantial public interest.
- **TECHNICAL TRANSLATION.** English-language translations of foreign scientific and technical material pertinent to NASA's mission.

Specialized services also include organizing and publishing research results, distributing specialized research announcements and feeds, providing help desk and personal search support, and enabling data exchange services.

For more information about the NASA STI program, see the following:

- Access the NASA STI program home page at <http://www.sti.nasa.gov>
- E-mail your question via the internet to help@sti.nasa.gov
- Fax your question to the NASA STI Help Desk at 443-757-5803
- Phone the NASA STI Help Desk at 443- 757-5802
- Write to:
NASA Center for Aerospace Information (CASI)
7115 Standard Drive
Hanover, MD 21076-1320

NASA/TP-2009-214769



A Summary of NASA and USAF Hypergolic Propellant Related Spills and Fires

B. M. Nufer
Kennedy Space Center, Florida

National Aeronautics and
Space Administration

Kennedy Space Center
Kennedy Space Center, FL 32899-0001

June 2009



Acknowledgements

*I would like to thank
the following people for their
very generous help and support in
putting together this difficult document:
Thomas Draus, David Shinn, Shaun Butts,
Ronald Rehagen, Walter Schmitz, Andrew Maffe,
Thomas Dempsey, John "Jack" Jamba, Kurt Rathgeber,
Conrad Perez, Manfred Heinrich, Charles Pierce, Frank Golan,
Gregory Kamp, Robert Dougert, Dallas McCarter, Jeffry Skaja, Larry
Ross, Michael Slusher, Mark Raysich, Mike Stefanovic, Donald Clarkson,
Chuck Davis, Joe Nieberding, Chad Summers, Jason Clark, Dr. Jeffry Meyers,
David Koci, Frank Norris, Jean Hill, Benjamin Greene, and my wife, Jennifer Nufer*

The use of trademarks or names of manufacturers in this report is for accurate reporting and does not constitute an official endorsement, either expressed or implied, of such products or manufacturers by the National Aeronautics and Space Administration.

Available from:

NASA Center for AeroSpace Information
7115 Standard Drive
Hanover, MD 21076-1320
443-757-5802

Abstract

Several unintentional hypergolic fluid related spills, fires, and explosions from the Apollo Program, the Space Shuttle Program, the Titan Program, and a few others have occurred over the past several decades. Spill sites include the following government facilities: Kennedy Space Center (KSC), Johnson Space Center (JSC), White Sands Test Facility (WSTF), Vandenberg Air Force Base (VAFB), Cape Canaveral Air Force Station (CCAFS), Edwards Air Force Base (EAFB), Little Rock AFB, and McConnell AFB. Until now, the only method of capturing the lessons learned from these incidents has been “word of mouth” or by studying each individual incident report.

The root causes and consequences of the incidents vary drastically; however, certain “themes” can be deduced and utilized for future hypergolic propellant handling. Some of those common “themes” are summarized below:

- Improper configuration control and internal or external human performance shaping factors can lead to being falsely comfortable with a system
- Communication breakdown can escalate an incident to a level where injuries occur and/or hardware is damaged
- Improper propulsion system and ground support system designs can destine a system for failure
- Improper training of technicians, engineers, and safety personnel can put lives in danger
- Improper PPE, spill protection, and staging of fire extinguishing equipment can result in unnecessary injuries or hardware damage if an incident occurs
- Improper procedural oversight, development, and adherence to the procedure can be detrimental and quickly lead to an undesirable incident
- Improper materials cleanliness or compatibility and chemical reactivity can result in fires or explosions
- Improper established “back-out” and/or emergency safing procedures can escalate an event

The items listed above are only a short list of the issues that should be recognized prior to handling hypergolic fluids or processing vehicles containing hypergolic propellants. The summary of incidents in this report is intended to cover many more issues than those listed above.

Table of Contents

Abstract	v
Table of Contents	vi
1 Introduction	1
1.1 Properties of Nitrogen Tetroxide (N ₂ O ₄)	2
1.2 Properties of Hydrazine (N ₂ H ₄)	3
1.3 Properties of Monomethylhydrazine (MMH)	5
1.4 Summary of Hypergolic Fluid Properties	6
2 Apollo 7 SPS N ₂ O ₄ Spill (September 1968, CCAFS LC-34)	7
3 Apollo-Soyuz Astronaut N ₂ O ₄ Vapor Exposure (7/24/1975, Apollo-Soyuz Test Project Apollo Command Module During Re-Entry)	9
4 OV-101 APU 1 Cavity Seal N ₂ H ₄ Spill (6/28/1977, Second Captive-Active Flight)	11
5 Titan II Silo Large Scale N ₂ O ₄ Spill (8/24/1978, McConnell AFB Silo 533-7)	12
6 N ₂ H ₄ Spill Following APU Hotfire (11/1979, KSC OPF1)	14
7 Titan II Explosion Following A-50 Spill (9/18/1980, Little Rock AFB Silo 374-7)	14
8 KSC Incorrect Flight Cap N ₂ O ₄ Vapor Release (July 1981, KSC OPF1)	17
9 MMH Exposure Following Flexhose Removal at Pad Farm (7/14/1981, KSC Pad 39A Fuel Farm) ..	18
10 STS-2 OV-102 Right Pod MMH Fire (Fall 1981, KSC OPF1)	18
11 STS-2 OV-102 N ₂ O ₄ Spill (9/22/1981, KSC Pad 39A 207-Foot Level)	19
12 Pad 39A Fuel Farm MMH Spill and Fire Following Pneumatic Valve R&R (6/29/1982, KSC Pad 39A Fuel Farm)	23
13 N ₂ O ₄ Vapor Release from Flange Gasket (2/10/1983, KSC Pad 39A Oxidizer Farm)	25
14 FRCS Ferry Plug Removal MMH Spill (4/18/1983, KSC OPF1)	25
15 STS-9 OV-102 APU-1 and -2 Explosion (12/8/1983, EAFB Runway 170)	26
16 N ₂ O ₄ Vapor Release from Loose Fitting (2/17/1984, KSC OPF2)	28
17 CCAFS Tanker MMH Fire (5/16/1984, CCAFS FSA 1)	29
18 Liquid Trap in Purge Adapter Flexhose MMH Spill (5/24/1985, KSC OPF1)	30
19 STS-61C OV-102 SRB HPU Loading N ₂ H ₄ Spill (12/8/1985, KSC Pad 39A MLP Surface)	31
20 Inadvertent Dry Well Removal MMH Spill (1/21/1986, KSC Pad 39A Fuel Farm)	31
21 Relief Valve R&R Oxidizer Farm N ₂ O ₄ Vapor Release (7/29/1986, KSC Pad 39A)	33
22 OPF2 Trench N ₂ H ₄ Spill and Fire (9/19/1986, KSC OPF2)	34
23 N ₂ O ₄ and Insulation Adhesive Small Fire (6/23/1988, KSC Pad 39B Oxidizer Farm)	35
24 STS-26R OV-103 N ₂ O ₄ Tubing Leak on Vehicle (7/14/1988, KSC Pad 39B)	36
25 WSTF Fuel Waste Flash Fire (2/16/1990, WSTF)	40
26 Aspiration of N ₂ O ₄ into Fuel Vent System (3/26/1990, WSTF TS 401)	40
27 HMF Screens Test Drum MMH Spill (12/7/1990, KSC HMF M7-961 East Test Cell)	41
28 STS-42 OV-103 Ferry Plug Removal MMH Spill (2/12/1992, KSC OPF3)	41
29 WSTF Incorrect Flight Cap N ₂ O ₄ Exposure (11/4/1992, WSTF)	42
30 Thermochemical Test Area N ₂ O ₄ Vapor Release (4/21/1994, JSC Building 353)	42
31 Titan IV A K-9 N ₂ O ₄ Spill (8/20/1994, CCAFS SLC-41)	43
32 STS-69 OV-105 Left Pod MMH Fire (12/9/1994, KSC OPF1)	46
33 STS-69 OV-105 Right Pod MMH Fire (5/4/1995, KSC OPF1)	47
34 ORSU Open Manual Valve N ₂ O ₄ Spill (3/1/1996, WSTF 400-Area)	51
35 OPF2 GSE MMH Spill (2/17/1997, KSC OPF2)	51
36 HMF Sample Valve MMH Spill (3/26/1997, KSC HMF M7-1212 West Test Cell)	53
37 VAFB Titan IV A K-18 N ₂ O ₄ Spill (7/16/1997, VAFB SLC-4E)	54
38 Pad 39B Slope N ₂ O ₄ Spill (11/6/1997, KSC Pad 39B Slope)	58
39 STS-109 OV-102 APU Hydrazine Spill (8/20/1999, KSC OPF3)	61
40 WSTF Pathfinder Axial Engine Valve Failure (8/7/2000, WSTF TS 401)	62
41 WSTF Pathfinder Small MMH Fire (8/12/2000, WSTF TS 401)	63
42 WSTF Pressure Transducer Explosion (3/25/2003, WSTF TC 831)	63
43 Titan IV N ₂ O ₄ Pump Explosion (8/12/2003, CCAFS LC-40)	65
44 HMF RP01 N ₂ O ₄ Spill (6/5/2004, KSC HMF M7-961 East Test Cell)	68
45 WSTF N ₂ H ₄ Spill Following Manual Valve Failure (9/30/2005, WSTF TC 844B)	69

46	STS-121 FRC3 N ₂ O ₄ Spill (1/9/2006, KSC HMF M7-1212 West Test Cell)	72
47	Conclusion.....	77
48	References	81
49	Appendix A: Acronyms and Abbreviations	86
50	Appendix B: Summary of Incidents	88
51	Appendix C: Detailed Assessment of Incidents	97

1 Introduction

Hypergolic fluids are toxic liquids that react spontaneously and violently when they contact each other. These fluids are used in many different rocket and aircraft systems for propulsion and hydraulic power including, orbiting satellites, manned spacecraft, military aircraft, and deep space probes. Hypergolic fuels include hydrazine (N_2H_4) and its derivatives including monomethylhydrazine (MMH), unsymmetrical di-methylhydrazine (UDMH), and Aerozine 50 (A-50), which is an equal mixture of N_2H_4 and UDMH. The oxidizer used with these fuels is usually nitrogen tetroxide (N_2O_4), also known as dinitrogen tetroxide or NTO, and various blends of N_2O_4 with nitric oxide (NO).

Several documented, unintentional hypergolic fluid spills and fires related to the Apollo Program, the Space Shuttle Program, and several other programs from approximately 1968 through the spring of 2009 have been studied for the primary purpose of extracting the lessons learned. Spill sites include KSC, JSC, WSTF, CCAFS, EAFB, McConnell AFB, and VAFB. Some spills or fires may not be captured in this document as a result of it covering several different worksites and spanning several decades.

The Space Transportation System's (STS) Orbital Maneuvering System and Reaction Control System (OMS/RCS) use hypergolic propellants to provide on-orbit maneuvering and de-orbit capabilities. Processing of the Space Shuttle orbiters occurs at the National Aeronautics and Space Administration's (NASA) Kennedy Space Center (KSC) near Titusville, Florida; on-orbit operations are managed by NASA's Johnson Space Center (JSC) in Houston, Texas; and hypergolic rocket engine checkout and testing occurs at NASA's White Sands Test Facility (WSTF) in Las Cruces, New Mexico. The only exception to processing was when the orbiters were previously sent to Palmdale, California for an Orbiter Maintenance Down Period (OMDP). For OMDP the OMS/RCS pods/modules were typically removed from the orbiters (as they are a completely removable and replaceable unit) and transported to KSC's Hypergolic Maintenance Facility (HMF).

NASA Procedural Requirement (NPR) 8621.1 revision B was used as a classification guideline to establish the following mishap related definitions:

Incident – An occurrence of a mishap or close call.

NASA Mishap – An unplanned event that results in at least one of the following:

- a. Injury to non-NASA personnel, caused by NASA operations.
- b. Damage to public or private property (including foreign property), caused by NASA operations or NASA-funded development or research projects.
- c. Occupational injury or occupational illness to NASA personnel.
- d. NASA mission failure before the scheduled completion of the planned primary mission.
- e. Destruction of, or damage to, NASA property except for a malfunction or failure of component parts that are normally subject to fair wear and tear and have a fixed useful life that is less than the fixed useful life of the complete system or unit of equipment, provided that the following are true: 1) there was adequate preventative maintenance; and 2) the malfunction or failure was the only damage and the sole action is to replace or repair that component.

Proximate Cause – The event(s) that occurred, including any condition(s) that existed immediately before the undesired outcome, directly resulted in its occurrence and, if eliminated or modified, would have prevented the undesired outcome. The proximate cause is also known as the direct cause(s).

Root Cause – One of multiple factors (events, conditions, or organizational factors) that contributed to or created the proximate cause and subsequent undesired outcome and, if eliminated or modified, would have prevented the undesired outcome. Typically, multiple root causes contribute to an undesired outcome.

These definitions are utilized for the categorization of all the incidents discussed in this document. A summary of the categorizations can be seen in Appendix C: Detailed Assessment of Incidents.

The intent of this report is to provide a lessons learned resource that can be utilized for future hypergolic system designs and operations. There have been several incidents involving injuries and damage to high value hardware that could have been prevented by utilizing the specific knowledge and preventative safety measures that are discussed in this document. Numerous engineers were interviewed that have been involved with the Space Shuttle Program since its genesis and the other programs that are mentioned. The following incidents capture what they could remember.

The discussions in this report are by no means intended to accuse or “point fingers” by placing blame where it may not be appropriate. The study of incidents and mishaps is crucial for the successful future of the space program. Prior to the discussion on the particular incidents, the following three sub-sections discuss properties of three hypergolic propellants. One must understand the physics and physiological effects of these chemicals before being able to study and understand incidents involving them.

1.1 Properties of Nitrogen Tetroxide (N₂O₄)

Nitrogen tetroxide is a strong oxidizing agent that is used with the hydrazine family of fuels for rocket propulsion in the vacuum of space. It was accepted as the rocket propellant oxidizer of choice in the early 1950's by the U.S.S.R. and the United States. N₂O₄ itself is nonflammable, non-explosive, and does not exothermically decompose; however, when added to a fire it will increase the intensity of combustion and burning rate by providing an additional oxygen source to the air. N₂O₄ is highly corrosive and extremely toxic. N₂O₄ is a liquid in equilibrium with nitrogen dioxide (NO₂) vapor: N₂O₄ (liquid) ↔ 2NO₂ (vapor). This equilibrium favors the vapor with increasing temperature and/or decreasing pressure. This is reversible when the conditions are the opposite. N₂O₄ is available in various “grades” ranging from pure N₂O₄ to 25% NO. The grade of nitrogen tetroxide oxidizer used in the Space Shuttle orbiters in the OMS/RCS has a 3% NO content (mixed oxides of nitrogen = 3% or MON-3).

When N₂O₄ liquid or NO₂ vapors come in contact with skin, eyes, or the respiratory system, the oxides of nitrogen react with water to produce nitric (HNO₃) and nitrous (HONO) acids that typically destroy tissue. Together, these compounds oxidize the moist and flexible inner tissue of the alveoli sacs within the lungs when inhaled. The alveoli sacs are the location in which the oxygen and carbon dioxide exchange takes place that is necessary for respiration. Adequate exposure will cause these affected areas oxidative stress and cellular death. The pulmonary capillaries are the next to die. When this occurs, the plasma diffuses through the vessel walls in the lungs, resulting in a build-up of fluid (edema). Since the fluid accumulation results from pulmonary vessel failure, the effect and symptoms may not be immediate. However, at high enough concentrations, immediate death from hypoxia could occur as a result of airway spasm, oxygen displacement, or reflex respiratory arrest. Delayed death could occur as a result of significant fluid build-up leading to respiratory failure. In non-mortal exposure cases, tissue may heal with scarring (in the location where the tissue was significantly exposed), leading to bronchiolitis obliterans (destruction of the small airways and air sacs). Survivors may have varying degrees of permanent restrictive lung disease with pulmonary fibrosis.

N₂O₄ (NO₂) vapors are approximately three times heavier than air and liquid N₂O₄ evaporates about five times faster than water at room temperature. The vapors of MON-3 are usually reddish-brown in color, which is caused by rapid vaporization of NO₂. Liquid N₂O₄ and its vapors will explode on contact with hydrazine fuels, amines, and alcohol. Ignition may also occur when N₂O₄ comes into contact with wood, paper, hydrocarbon fuels, and some adhesives. A mixture of N₂O₄ and halogenated solvents: carbon tetrachloride, TCE, perchloroethylene, etc., may produce a violent explosion. MON-3 N₂O₄ has the following properties:

- Molecular Weight 92.016
- Relative Vapor Density 1.58
- N₂O₄ + NO, % 99.5

• Boiling Point (14.7 psia), °F	70.1
• Freezing Point, °F	11.8
• Vapor Pressure (70 °F), psia	14.57 ($V_p[\text{psi}] = 10^{\{ 5.247 - 2654 / (T[\text{R}] + 0.00175 * (T[\text{R}]) \}}$)
• Specific Gravity (77 °F)	1.423
• Ignition Capability	Not flammable
• Odor	Bleach-like
• Odor Threshold, ppm	1 to 3
• REL, ppm (parts per million)	1.0 (exposure limit for NASA hardware processing)
• Density (77 °F & 14.7 psia), lbm/gal	11.96 ($\text{Density}[\text{lbm}/\text{ft}^3] = 95.499 - 0.07804 * (T[^\circ\text{F}]) + 0.00072 * (P[\text{psig}])$)

References: SP-086-2001; Hall; Rathgeber; Myers

1.2 Properties of Hydrazine (N₂H₄)

German chemist Hermann Emil Fischer was the first to discover a hydrazine derivative (phenylhydrazine to be exact) in 1875. Later in 1889, free hydrazine (N₂H₄) was first synthesized by German Chemist Dr. Julius Wilhelm Theodor Curtius. Hydrazine and its derivatives are used in the pharmaceutical, fertilizer, and polymer industries along with its vast use for propulsion and hydraulic power of spacecraft and military aircraft.

Currently, monopropellant grade hydrazine (N₂H₄) is the fuel used in the Auxiliary Power Units (APU) on the Space Shuttle orbiters and the Hydraulic Power Units (HPU) on the Space Shuttle Solid Rocket Boosters (SRBs). N₂H₄ is also used on many spacecraft for monopropellant rocket propulsion (on the order of single digits to hundreds of pounds of thrust per rocket engine). To produce thrust, monopropellant rockets utilize a metal-based agent to catalytically decompose the N₂H₄ into ammonia, nitrogen, and hydrogen. Liquid hydrazine contains about 98.5% pure N₂H₄ with the remaining 1.5% being primarily water. Aerozine 50 (along with N₂O₄) was used for the first and second stages of the Titan II Intercontinental Ballistic Missile (ICBM) and Titan space launch vehicles including the 23G (a variant of the Titan II used for launching medium-sized spacecraft), IIIB, IIIC, and IV. The Titan II, IIIB, IIIC, and IV rockets used the largest quantities of hypergols per launch in the history of the United States rocket fleet (for the first stage approximately 13,000 gallons of N₂O₄ and 11,000 gallons of A-50 was used along with 3,100 gallons of N₂O₄ and 1,700 gallons of A-50 for the second stage).

The Occupational Safety and Health Administration (OSHA) classifies N₂H₄ and its derivatives as a possible carcinogen. N₂H₄ and its derivatives are extremely toxic, highly flammable, and highly corrosive. "Hydrazines and their vapors explode on contact with strong oxidizers, such as N₂O₄, hydrogen peroxide, fluorine, and halogen fluorides. Additionally, they react on contact with metallic oxides, such as iron, copper, lead, manganese, and molybdenum to produce fire or explosion," as quoted from George Hall. See Figure 1-1 for more information on hydrazine material compatibility as compared to pure titanium. Metals to the right of titanium in Figure 1-1 are less compatible with hydrazine than titanium. Metals to the left are more compatible. Material compatibility is quantified on a relative basis as a result of variables in the systems that contain the materials including pressures and thermal characteristics.

Hydrazine fires produce little to no smoke or colorful flames. N₂H₄ has a tendency to react exothermically with or without an oxidizer present (the reaction increases the temperature thus increasing the reaction rate; this is also known as a thermal runaway reaction). Another way to describe a hydrazine thermal runaway reaction is "...the rate of heat generation by the reaction exceeds the rate of heat removal from the system," as quoted from F. J. Benz. This process is directly related to the auto-ignition temperature, which decreases as pressure increases. The exothermic reaction can end in an explosion if one or more of the following conditions are met within the system containing the hydrazine: the reacting system is confined to a rigid volume; the reacting system is adiabatic or nearly adiabatic; the reaction rate increases with temperature; or if the hydrazine is subjected to rapid over-pressurization through "water hammer," as stated in SP-085-1999. The flammability regions for MMH and N₂H₄ are shown in Figure 1-2.

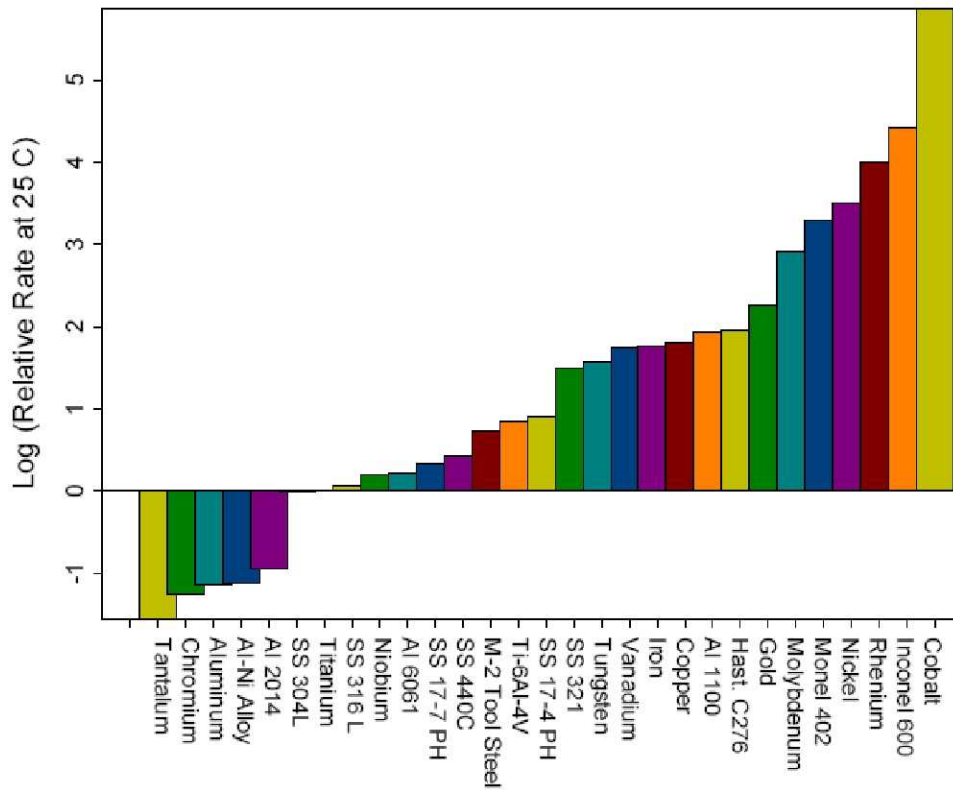

Figure 1-1: Hydrazine Reactivity Relative to Commercially Pure Titanium

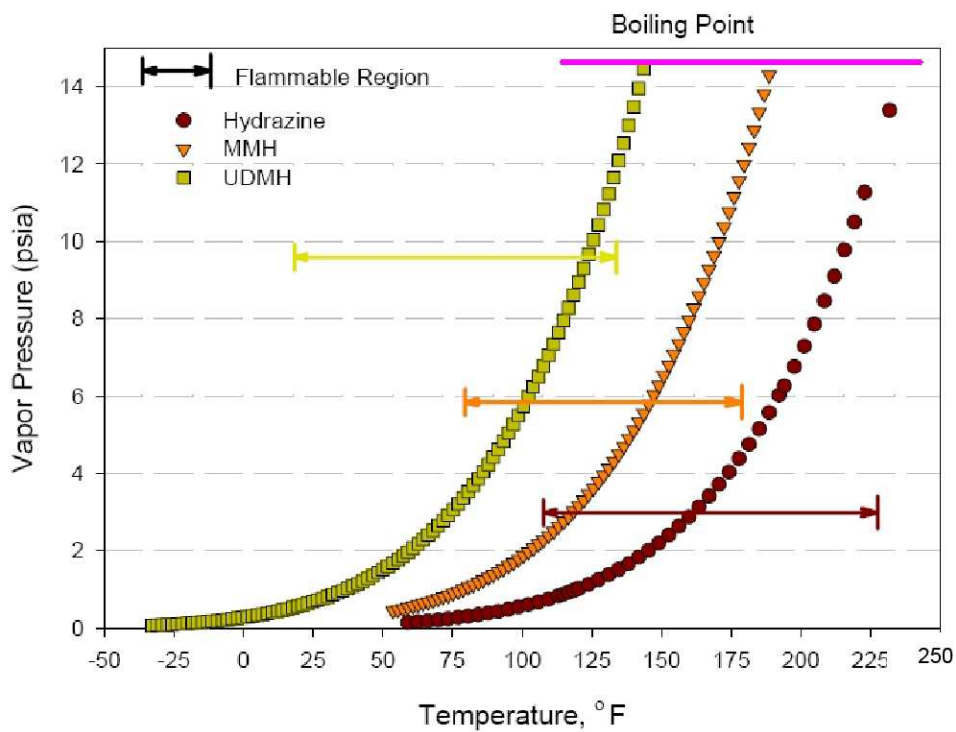

Figure 1-2: Flammability Regions for MMH and Hydrazine

The vapor densities of all hydrazines are greater than air. Hydrazine evaporates at approximately the same rate as water at room temperature. N_2H_4 liquid at room temperature and pressure is clear and oily. N_2H_4 and MMH are hygroscopic (they readily absorb water); therefore, water is widely used as a diluting agent. A liquid mixture of 58% water and 42% hydrazine or MMH by weight prevents ignition in an open air environment. A vapor mixture of 65% water and 35% hydrazine or MMH is considered nonflammable in air. The following are properties of N_2H_4 :

• Molecular Weight	32.04516
• Boiling Point (14.7 psia), °F	237.6
• Freezing Point, °F	34.75
• Vapor Pressure (77 °F), psia	0.96
• Ignition Capability	4.7 to 100% by volume in air
• Auto-ignites, °F	437 in air, 984 in GN_2 , (increases with decreasing pressure)
• Ratio of Specific Heat (gas)	1.19
• Odor	Ammonia; fishy
• Odor Threshold, ppm	2 to 3
• TLV-TWA, ppm	0.01 (exposure limit for NASA hardware processing)
• Density (77 °F & 14.7 psia), lb_m/gal	8.38

References: SP-084-1999; SP-085-1999; Hall; Rathgeber; Benz; Occupational Exposure to Hydrazines

1.3 Properties of Monomethylhydrazine (MMH)

Monomethylhydrazine is the fuel used in the OMS/RCS on the Space Shuttle orbiters. Monomethylhydrazine, $N_2H_3(CH_3)$, is similar to hydrazine, N_2H_4 , with the exception that it contains a methyl group in its molecule in place of one hydrogen atom (see Figure 1-3 for an illustration of this). Most rocket grade MMH contains 98% pure $N_2H_3(CH_3)$ with the remaining 2% being primarily water. MMH is not used for monopropellant rocket propulsion because the carbon formed in its decomposition contaminates the catalyst. It is extremely toxic, highly flammable, and highly corrosive. MMH has greater compatibility with metals as compared to N_2O_4 as shown in Figure 1-4. All metals with a relative reactivity rate of one in Figure 1-4 have equal compatibility to titanium. Items below titanium (with a relative reactivity rate of greater than one) are less compatible.

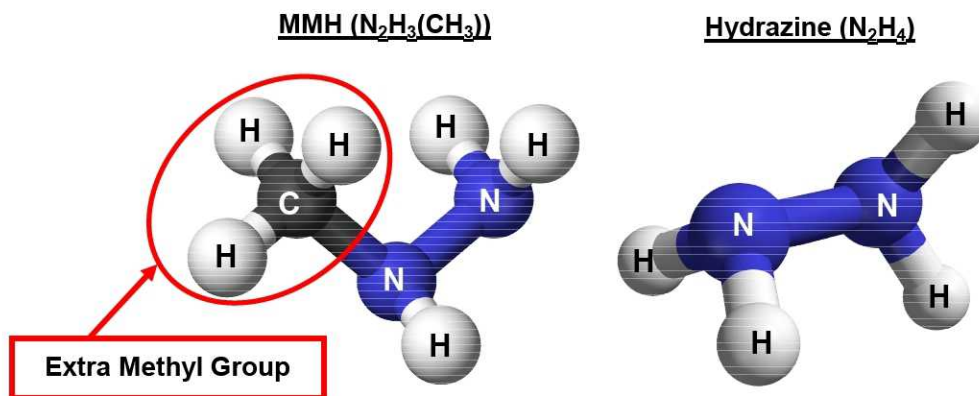

Figure 1-3: MMH and Hydrazine Molecules

MMH may have a slight yellow-orange tinted flame. MMH can also react exothermically with or without an oxidizer present, but the reaction rate has been found to be much slower than N_2H_4 . MMH vapor has also been found to be much less sensitive to detonation as compared to N_2H_4 . As a result of the molecular differences in comparison to N_2H_4 , MMH has slightly different properties as shown below:

- Molecular Weight 46.075
- Boiling Point (14.7 psia), °F 189.5
- Freezing Point, °F -62.5
- Vapor Pressure (77 °F), psia 3.23
- Ignition Capability 2.5 to 98% by volume in air
- Auto-ignites in air, °F 286 to 386 (increases with decreasing pressure)
- Ratio of Specific Heat (gas) 1.13
- Odor Amine; fishy
- Odor Threshold, ppm 1 to 3
- TLV-TWA, ppm 0.01 (exposure limit for NASA hardware processing)
- Density (77 °F & 14.7 psia), lb_m/gal 7.27
 (Density [lb_m/ft³] = 56.926 - 0.03231*(T [°F]) + 0.000252*(P [psig]))

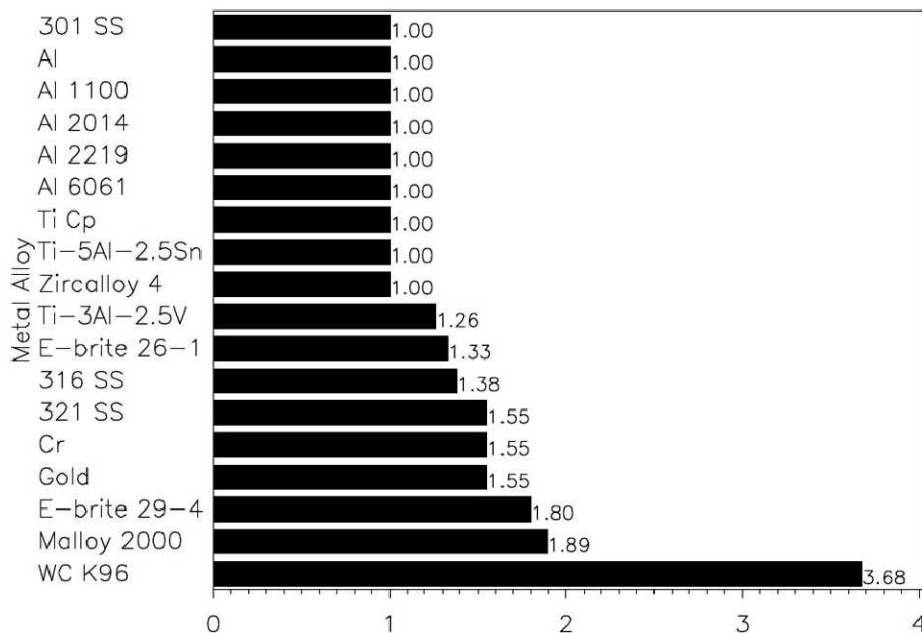

Figure 1-4: MMH Reactivity Relative to Commercially Pure Titanium (at 353 K)

References: SP-085-1999; Hall; Rathgeber; Benz

1.4 Summary of Hypergolic Fluid Properties

NASA follows a strict time weighted average exposure concentration limit for N₂H₄, MMH, and N₂O₄ for personnel safety during vehicle processing. The agency chose the lowest acceptable limit (Time weighted average or TWA) from the Occupational Safety and Health Administration’s Permissible Exposure Limit (OSHA PEL), the National Institute of Occupational Safety and Health’s Recommended Exposure Limit (NIOSH REL), and the American Conference of Governmental Industrial Hygienists’ Threshold Limit Value (ACGIH TLV) for its guidelines. From these organizations, NASA established that the threshold limit value (TLV) for N₂H₄ and MMH would be 0.01 ppm for a conventional 8-hour work day and 40-hour work week. The NASA limit for N₂O₄ exposure was taken from the NIOSH REL ceiling in which 1.0 ppm is the maximum limit during any part of the workday. A value of 3 ppm is the limit for N₂O₄ during a conventional 8-hour work day and 40-hour work week.

It may seem odd that with all these seemingly negative characteristics, spacecraft designers still choose to use hypergols for propulsion systems. This is primarily due to the fact that hypergols are storable and

stable (as long as they are contained properly). They also have a high specific impulse when used for propulsion, are stable to impact as long as there is no spark, can withstand the extremes of hot and cold which are present in the vacuum of space, and can be frozen and then thawed without detrimental effects to the chemical properties or storage vessels since they contract when frozen. However, care needs to be taken when hypergols are frozen in tubing. The volume of the propellant in the solid state is less than it is in the liquid state; therefore, as the propellant freezes, additional liquid fills the void created by the decrease in volume. When the propellant thaws, there is not enough volume to contain the liquid and the line bursts as a result of an over-pressurization, depending on the thaw pattern in the tubing. This is why thermal control of tubing is very important in hypergol systems.

2 Apollo 7 SPS N_2O_4 Spill (September 1968, CCAFS LC-34)

In mid-September, 1968 on the mobile Service Structure of Launch Complex 34 (LC-34) at CCAFS there was an N_2O_4 spill of approximately one to two gallons during post-servicing operations of the Apollo Service Propulsion System (SPS). A cutaway view of the SPS is shown in Figure 2-1. The mobile Service Structure is shown in reference to the LC-34 launch pad in Figure 2-2. The servicing was being completed in preparation for the scheduled October, 1968 launch of the first manned Apollo Program mission-Apollo 7 with the crew of Wally Schirra (Commander), Donn Eisele (Command Module Pilot), and Walter Cunningham (Lunar Module Pilot, even though there was not a lunar module on this mission utilizing a Saturn IB launch vehicle).

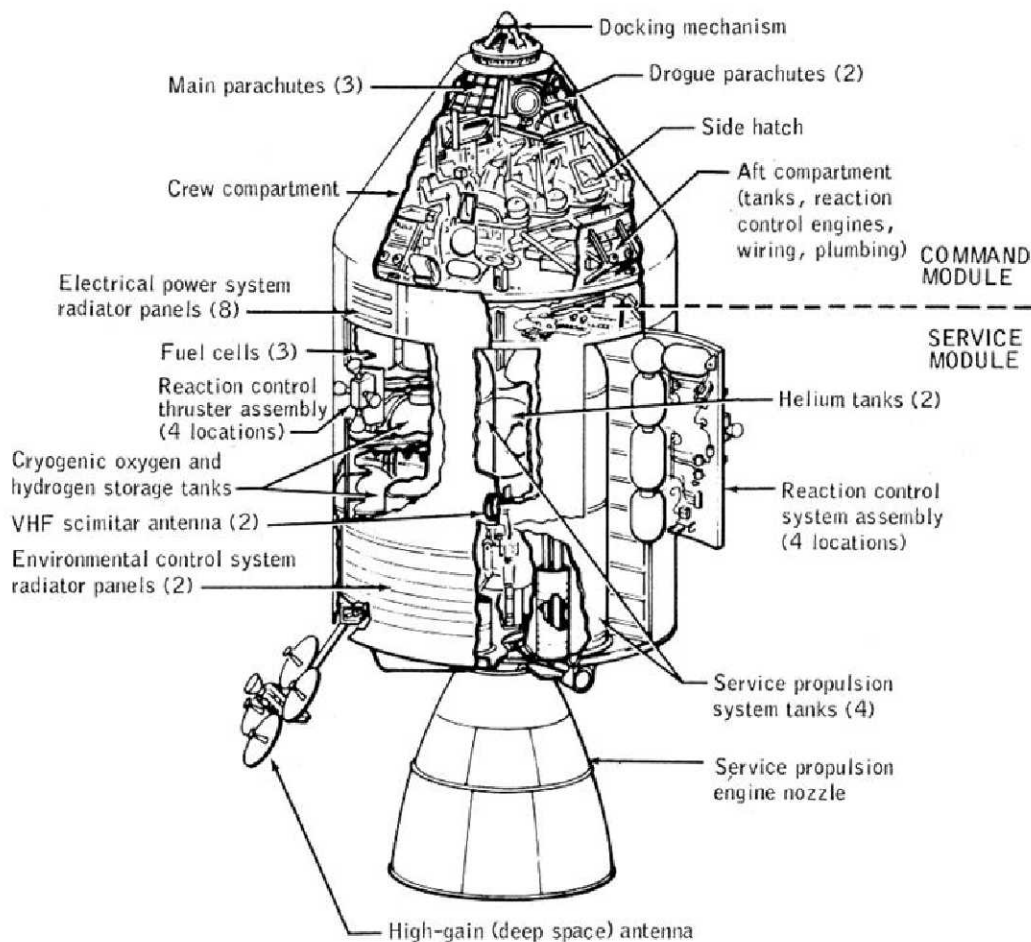

Figure 2-1: Apollo Command Module and Service Module

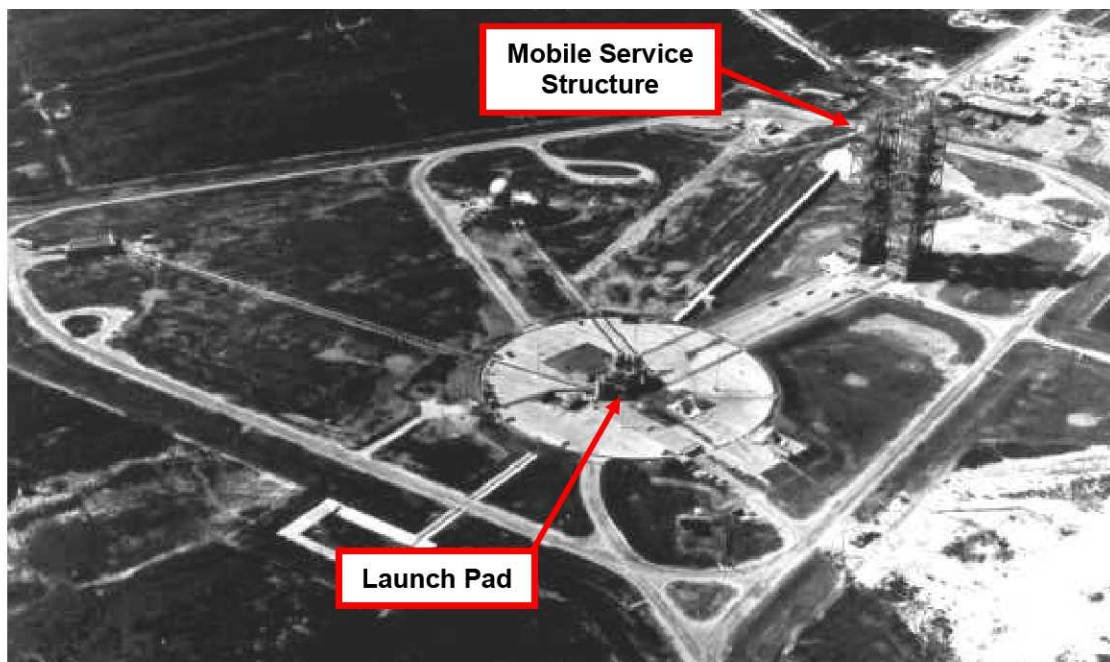

Figure 2-2: LC-34 Launch Pad and Service Structure (In Park Position)

The Apollo SPS hypergol loading ground support equipment (GSE) consisted of two six-wheeled, flat bed portable tanker trailers (one for oxidizer and one for fuel) that held heavy-walled storage tanks, control valves, and a control console. Prior to the loading operation, the trailer was staged approximately 200 feet from the base of the pad structure. The servicing GSE also included the portable servicing panels that were staged at the base of the LC-34 structure. These large panels (15 feet long, by 10 feet high, by 8 feet wide) contained pumps, valves, and electrical cabinets inside an enclosure. Portable air dilution scrubbers with liquid separators were also located at the base of the launch pad separate to the trailers. Each had three big fans to disperse the propellant vapor. Hard-line tubing carried the propellant up the launch pad structure. Flexhoses were connected to the hard-lines by flanges to transfer the propellant from the fixed structure to the mobile structure propellant delivery system, which consisted of a valve box with supply and return lines and a crossover three-way valve.

The N_2O_4 spill occurred when a technician was disconnecting the two-inch hard-line/flexhose flange. Engineers thought that they had performed an adequate drain and purge of the line; however, the technician discovered that this was not the case (proximate cause). When he began to unbolt the flange, about one to two gallons of liquid N_2O_4 poured out of the line onto the mobile Service Structure and flight vehicle. Liquid N_2O_4 ran down the side of the vehicle and into the instrument unit ring, as seen in Figure 2-3 in the Saturn 1B cutaway view. The liquid N_2O_4 was diluted with water, which turned out to be a poor decision since N_2O_4 and water form nitric and nitrous acids. A de-stack was completed to remove the instrument unit ring for repair.

It was found that the GSE propellant tubing contained a low point that trapped the liquid, not allowing it to be purged through the system during the post-operations of the loading procedure (root cause). This incident led to the requirement to install "spill protection" and "scuppers" onto the vehicle to capture any spilled liquid from the vehicle. The scupper is a box that is attached to the vehicle servicing door that serves the dual purpose of spill containment and carrying the loads that the external GSE hoses place on the vehicle servicing valves and fluid lines. An additional requirement was also developed mandating that GSE designs be free of low point liquid traps.

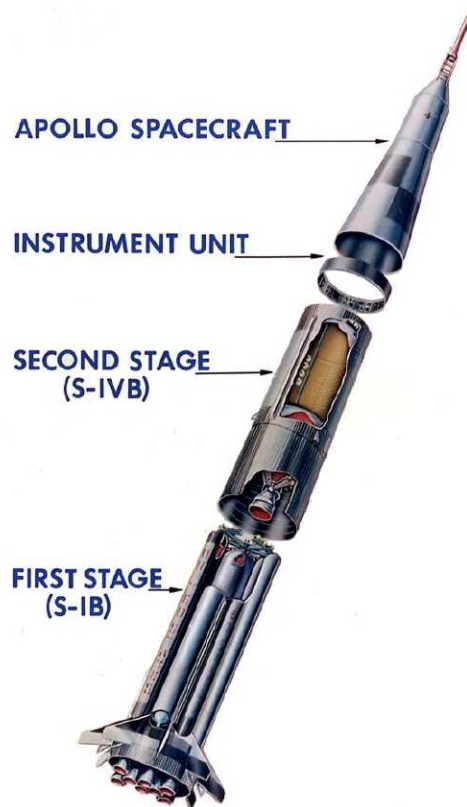

Figure 2-3: Saturn 1B Launch Vehicle

References: Benson; Perez

3 Apollo-Soyuz Astronaut N_2O_4 Vapor Exposure (7/24/1975, Apollo-Soyuz Test Project Apollo Command Module During Re-Entry)

During reentry on July 24, 1975, following the Apollo-Soyuz Test Project's nine-day international mission, Apollo-Soyuz astronauts, shown in Figure 3-1, Deke Slayton (front left), Thomas Stafford (back left), and Vance Brand (lower middle) were exposed to N_2O_4 (NO_2) vapors for approximately four minutes and forty seconds. The estimated peak cabin concentration was approximately 750 ppm with an average crew exposure of 250 ppm.

During reentry, the crew inadvertently performed a few tasks out sequence (root cause). The first task in the series was the opening of the cabin pressure relief valve to gradually equalize the cabin pressure with the outside air as the external ambient pressure increased during the capsule's descent. The following task was the manual deployment of the drogue parachute at approximately 23,000 feet. This activity caused the capsule to sway. The onboard guidance, navigation, and control computers sensed this motion and activated the Apollo command module's reaction control system (RCS) thrusters to counteract it (proximate cause). Non-combusted N_2O_4 (NO_2) vapors were subsequently drawn into the capsule through the open cabin relief valve exit port about two feet from the closest RCS thruster. About 30 seconds later, the crew deactivated the RCS thrusters; however, the capsule had already filled with N_2O_4 (NO_2) vapors. The thruster deactivation had been planned to be completed prior to the opening of the cabin pressure relief valve.



Figure 3-1: Apollo-Soyuz Test Project Crew

Brand describes the reentry events during the crew technical debriefing:

“At 30K [30,000 feet], normally we arm the ELS [Earth Landing System] AUTO, ELS LOGIC, that didn’t get done. Probably due to a combination of circumstance, I didn’t hear it called out, maybe it wasn’t called out. Any case 30K to 24K we passed through that regime very quickly. I looked at the altimeter at 24K, and didn’t see the expected apex cover come off. Didn’t see the drogues come out. So, I think at about 23K, I hit the two manual switches. One for the apex cover and also, the one for drogues. They came out. That same instant the cabin seemed to flood with a noxious gas, very high concentration it seemed to us. Tom said he could see it. I don’t remember for sure now, if I was seeing it, but I certainly knew it was there. I was feeling it and smelling it. It irritated the skin a little bit, and the eyes a little bit, and, of course, you could smell it. We started coughing. About that time, we armed the automatic system, the ELS...”

The exposure greatly altered the astronauts’ abilities to complete assigned tasks in a timely manner; therefore, they experienced a very rough landing along with the poor luck of having the capsule splash-down in the “Stable 2” configuration, which meant it was inverted in the water. Following splash-down, the crew was forced to don their oxygen masks, but in the interim before Stafford could retrieve and distribute the masks, Brand (who was sitting closest to the relief valve, see Figure 3-2) lost consciousness.

Stafford later reported:

“For some reason, I was more tolerant to [the NO₂ vapors], and I just thought get those damn masks. I said don’t fall down into the tunnel. I came loose and...had to crawl...and bend over to get the masks...I knew that I had a toxic hypoxia...and I started to grunt-breathe to make sure I got pressure in my lungs to keep my head clear. I looked over at Vance [Brand] and he was just hanging in his straps. He was unconscious.”

Stafford climbed around the module to Brand and placed an oxygen mask over his mouth. With the oxygen mask in place, Brand regained consciousness within approximately one minute. The capsule was then reoriented upright and Stafford opened the vent valve, dissipating the remaining vapors. All three astronauts subsequently developed pneumonitis, for which they were hospitalized for about two weeks in Honolulu, Hawaii. All three recovered completely. Deke Slayton and Thomas Stafford did not fly on any subsequent space missions. Vance Brand went on to be the commander for three Space Shuttle flights: STS-5, STS-41B, and STS-35.

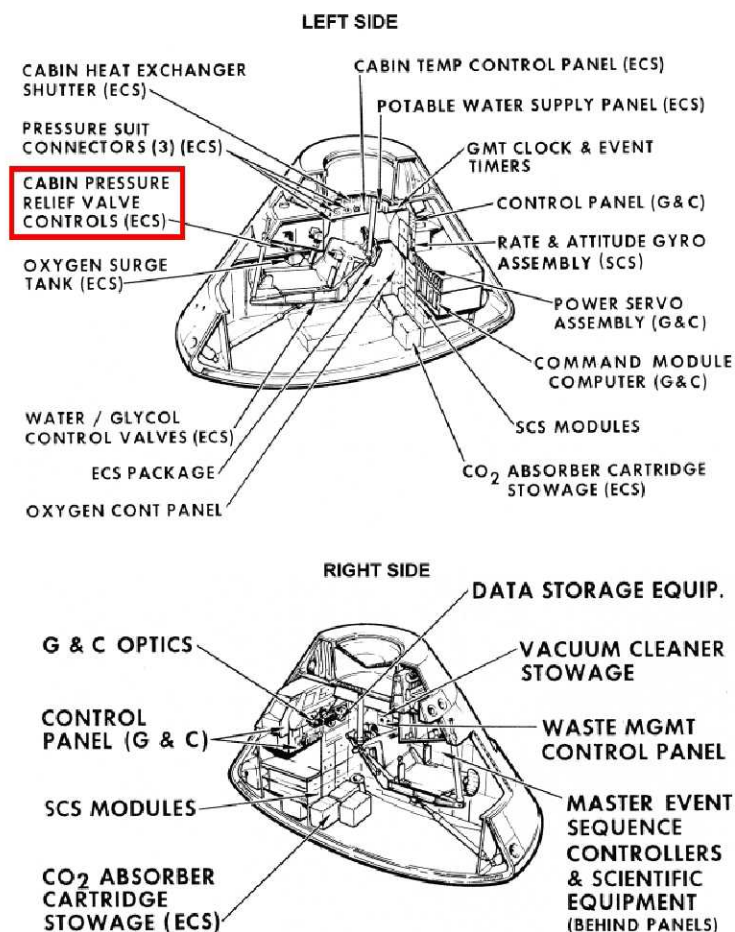

Figure 3-2: Apollo Command Module Interior Cutaway

References: Ezell; Apollo (ASTP)

4 OV-101 APU 1 Cavity Seal N₂H₄ Spill (6/28/1977, Second Captive-Active Flight)

On June 28, 1977, during Enterprise's (OV-101) second captive-active flight with the crew of Joe Engle and Richard Truly, approximately five gallons of hydrazine leaked from APU number one's cavity shaft seals and dumped overboard via the drain vent at the aft end of the vehicle. There was not a catch bottle in this early design. The incident resulted in a new design of the shaft seals and the addition of a catch bottle.

The aerodynamic slipstream of the vehicle caused the hydrazine to be ingested into the left hand side of the aft fuselage through an access panel and vent door. There were no reported fires. There was extensive damage to the polyimide "Kapton" insulated wiring and interior thermal blankets near the left hand APU service panel from hydrazine exposure. There was also damage to the exterior thermal blankets. This incident seemed to bring to light the incompatibility between hydrazine and Kapton. For future flights, the left- and right-hand vent ports were modified to eliminate the possibility of ingestion. Also, the left and right access doors and T-0 umbilical doors were sealed. The root cause of the leak was an inadequate understanding of the flight characteristics of the APU system. Finding these types of design faults are, however, the exact reason that flight tests are performed.

References: Demarchi; Olney; Lance

5 Titan II Silo Large Scale N₂O₄ Spill (8/24/1978, McConnell AFB Silo 533-7)

On August 24, 1978, at McConnell AFB southeast of Wichita, Kansas, the worst reported unintentional N₂O₄ spill in U.S. history took place. Approximately 13,450 gallons of liquid N₂O₄ spilled into the underground missile silo. Two members of the 381st Strategic Missile Wing were killed and 25 more were injured from N₂O₄ liquid and vapor exposure. The silo also suffered extensive damage. The Titan II first and second stages were an A-50/N₂O₄ bi-propellant propulsion system. The loading operations were completed using a holding tanker located above ground. Recall that N₂O₄ (NO₂) vapors are heavier than air and they boil at approximately 70 °F at ambient pressure.

Once the N₂O₄ loading of the rocket's first and second stages had been completed, all that remained was disconnecting the quick disconnects (QDs) from the rocket air half couplings (AHC). The technicians wearing Rocket Fuel Handler Coverall Outfits (RFHCOs) were unaware that a Teflon o-ring seal had dislodged from an upstream location, moved through the filter assembly (of which there were no filter elements installed), through the QD, and wedged itself in between the poppet of the AHC and its primary sealing surface on the Titan II (proximate cause) of the spill. This prevented the isolation of the bulk propellant in the first stage oxidizer tanks once the QD was removed. The RFHCOs were similar to Self-Contained Atmospheric Protection Ensemble (SCAPE) suits that are used by the Space Shuttle Program. When the technician mechanically separated the QD from the AHC, approximately 13,450 gallons of liquid N₂O₄ poured out of the AHC and into the missile silo.

Very high concentrations of NO₂ vapors traveled from the silo into the connecting cableway to the blast lock area, which was located just outside of the control center where several personnel were located (see Figure 5-1). All the personnel located in the blast lock area managed to escape the vapors by exiting through the access portal at ground level. The personnel in the control center would normally be isolated from the silo; however, two technicians involved in the spill opened the airlock door to try and obtain assistance for their supervisor who was in need of immediate medical attention. The two technicians and four other control center personnel then evacuated through the emergency escape hatch, once they realized the immediate danger of the situation. The nearby town of Rock, Kansas had to evacuate about 100 people as a result of the vapors that were escaping from the silo (see Figure 5-2).

It was later discovered that the suit of the supervisor had failed, introducing him to dangerous levels of N₂O₄ (NO₂) vapors, which was ultimately fatal to him within minutes of being exposed (see section 1.1 "Properties of Nitrogen Tetroxide (N₂O₄)" for a description of what N₂O₄ and NO₂ does to the body). Two other technicians had removed their suit hoods while in the vapor cloud. One died nine days later. The extent of the injuries of the other technician is uncertain; however, he did survive. Repairs to the damaged 533-7 silo were attempted, but later discontinued for budgetary reasons. The silo was never returned to alert status.

Lessons learned from this incident include the following:

- Proper configuration control of GSE components, in this case the filter, is highly important in the handling of toxic chemicals, especially hypergols (root cause of the incident)
- Emergency procedures and safing must always be reviewed, practiced, and ingrained in the minds of personnel working with toxic chemicals
- Procedural oversight may have been beneficial
- Proper isolation of bulk propellant should be inherently designed into any rocket propulsion system and used accordingly during loading operations
- Personal protective equipment (PPE) should be inspected prior to every use

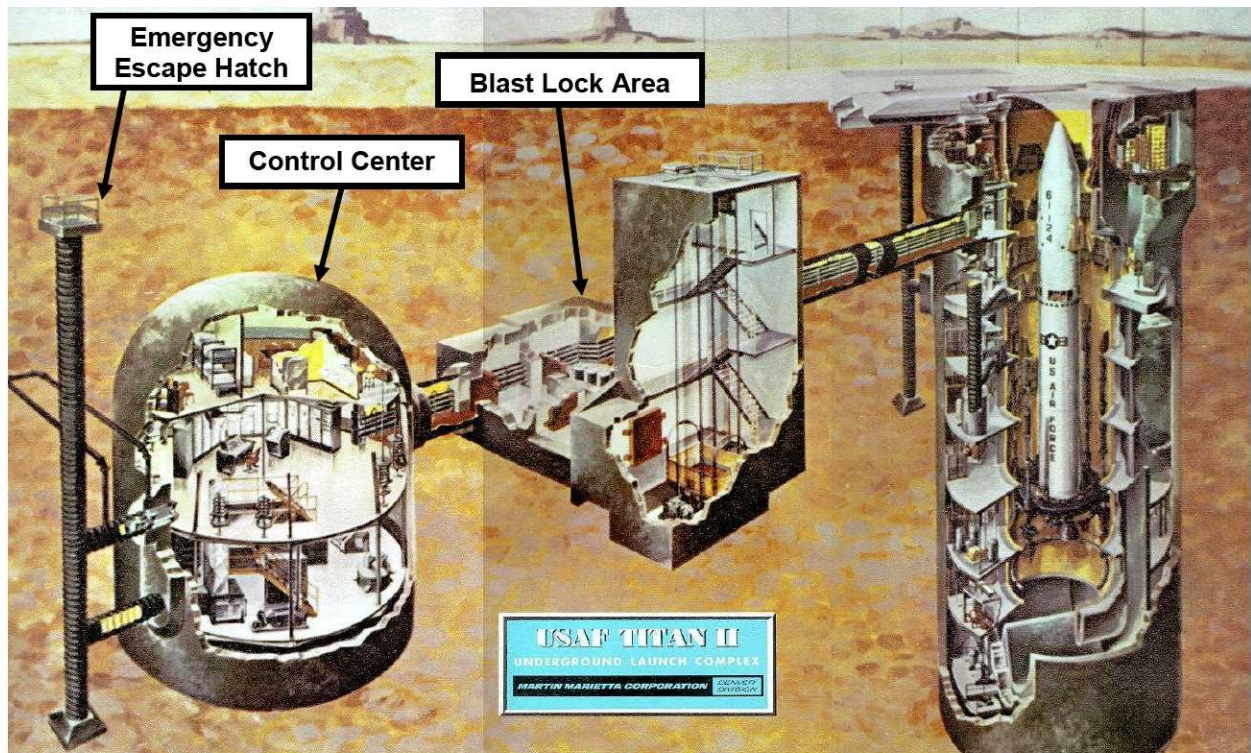

Figure 5-1: Underground Titan II Missile Complex



Figure 5-2: Aerial View of N₂O₄ Vapor Cloud Coming from Missile Silo 533-7

Reference: Rathgeber; Titan-II.com

6 N₂H₄ Spill Following APU Hotfire (11/1979, KSC OPF1)

In November of 1979, prior to the launch of STS-1 (Columbia), there was an N₂H₄ spill of approximately two gallons during the propellant tank offload procedure in Orbiter Processing Facility 1 (OPF1). The spill occurred following an APU hotfire, which was performed as part of Columbia's "dynamic stability" test to certify the vehicle for flight. APU hotfires were originally completed in the OPF using a vent that passed through the roof of the building to release the exhaust products. The source of the spill was found to be a leaking "gauge saver" in the APU hydrazine servicing cart (proximate cause). It was discovered that the gauge saver fittings had been replaced on the cart at Edwards Air Force Base (EAFB) following APU servicing for the Enterprise flight tests. The replacement gauge savers were later determined to contain brass bellows, which were not compatible with N₂H₄ (root cause). Following the shipment of the servicing cart to KSC, it was filled with N₂H₄ at the Pad 39A fuel farm and then used for the servicing of Columbia in OPF1 for the APU hotfire test. There were no reports of hardware damage or injuries. It is not certain, but this incident may have led to the practice of completing APU hotfires exclusively at the launch pad.

Reference: Heinrich; Dougert

7 Titan II Explosion Following A-50 Spill (9/18/1980, Little Rock AFB Silo 374-7)

On September 19, 1980, following a large A-50 spill the previous evening, the Titan II ICBM within missile silo 374-7 located about 2.5 miles south of Bee Branch, Arkansas, exploded. One of the 308th Strategic Missile Wing's airmen was killed and 21 other USAF personnel were injured as a result of the explosion and subsequent rescue operations.

At about 6:30 PM on September 18, 1980, an airman was conducting a maintenance operation on level two (see Figure 7-1) of the underground silo when he accidentally dropped a large wrench socket. The standing platforms were hydraulically-controlled, flip-down structures with a rubber boot mounted between the platform and the rocket. The socket fell hitting the standing level two platform and bounced in the direction of the rocket where it slipped through the small gap between the rubber boot (which had become pliable over the years) and the Titan II rocket. It fell about 70 feet before hitting the thrust mount near the base of the rocket. The socket then bounced into and ruptured the stage one fuel tank (proximate cause). Approximately 11,140 gallons of A-50 drained into the bottom of the silo. Fuel vapors heated up the silo and caused the pressures in the non-ruptured propellant tanks to rise substantially.

At about 8:00 PM the control center was evacuated (see Figure 5-1 for a view of the launch silo and supporting facilities) and, therefore, the capability to remotely monitor the silo and rocket system data was lost. The entire missile complex and the surrounding area were then evacuated and a team of specialists that were knowledgeable of the Titan II rocket system were called in from Little Rock AFB (the missile's main support base). Also, at around this time, local residents within a one-mile radius of the missile silo were evacuated. Local law enforcement officers closed the nearby State Highway 65, and alerted anyone entering the area.

At 3:00 AM on the following morning (September 19, 1980) two people entered the control center in protective suits through the emergency escape hatch. They were forced to leave shortly thereafter as a result of the high fuel vapor concentration causing poor visibility. Prior to leaving, one of the men reportedly activated the exhaust fans which pulled the fuel vapors into an equipment area where some electrical pumps were located. It is assumed that this is where the fire originated, however this was never completely proven. It is unclear if the men received orders from a superior officer to activate the exhaust fans or not. Following the exhaust fan activation, the two men went back to the surface and had just paused to await further instructions when the Titan II rocket exploded, sending an earthquake-like shockwave across north central Arkansas. The heat from the flames at the base of the silo increased the temperature at the lower end of the rocket. This eventually led to the rupture of the N₂O₄ tank, which reacted hypergolically with the spilled fuel causing the explosion. One of the two men died later that day in the hospital (once he was located among the rubble from the explosion). The other man was thrown approximately 150 feet from the silo and suffered only a broken leg along with several cuts and bruises.



Figure 7-1: Technicians Working on Fold-Down Platform in Titan Silo Level 2

It was reported that the explosion blew the 740-ton reinforced concrete and steel silo door (see Figure 7-2 for a depiction of the Titan II missile silo) 200 feet into the air and 600 feet from the silo. The rocket's second stage, with the W53 thermonuclear warhead attached, was launched out of the silo following the explosion of the first stage. The second stage then supposedly blew up in midair, (it contained about 1,730 gallons of A-50 and 3,120 gallons of N_2O_4) sending the undetonated warhead several hundred feet from the silo. The W53 warhead had a mass of 8,136 lb and a yield of 9,000 kilotons (the Hiroshima bomb "Little Boy" was estimated at about 15 kilotons). Luckily the warhead's safety features operated as they were designed. There was no reported loss of radioactive material.

The 374-7 Titan II missile silo complex was completely destroyed. The estimated value of the silo in 1980 was approximately \$225,000,000. In October of 1981, President Reagan announced that all of the Titan II ICBM launch sites across the United States would be deactivated by October of 1987. Along with this action being part of the strategic modernization program, the deactivation was related to this incident and the previously mentioned incident at McConnell AFB. Silo 374-7 was the first Titan II silo to be deactivated. The 308th strategic missile wing was completely deactivated on August 18, 1987.

Some lessons learned and corrective actions from this incident include:

- All workers should wear a belt with lanyards to attach tools
 - Operational human error is, therefore, the root cause
- Cloths should be placed on the platforms to prevent tools from bouncing off the metal
- The Titan II missile silo platforms should be renovated to increase safety
- The training and qualification program was insufficient prior to the incident (a root cause)
- Communication with local authorities was inadequate, especially with reference to the nuclear warhead
- Care should be taken to ensure the exclusive use of explosion proof hardware in a facility that contains hypergolic propellants
 - It is unclear if this incident was indeed caused by activating the exhaust fans; however, this is a still viable corrective action
- Sending personnel into an unknown situation is extremely dangerous, especially one in which an explosion is imminent as a result of the high concentration of fuel vapors

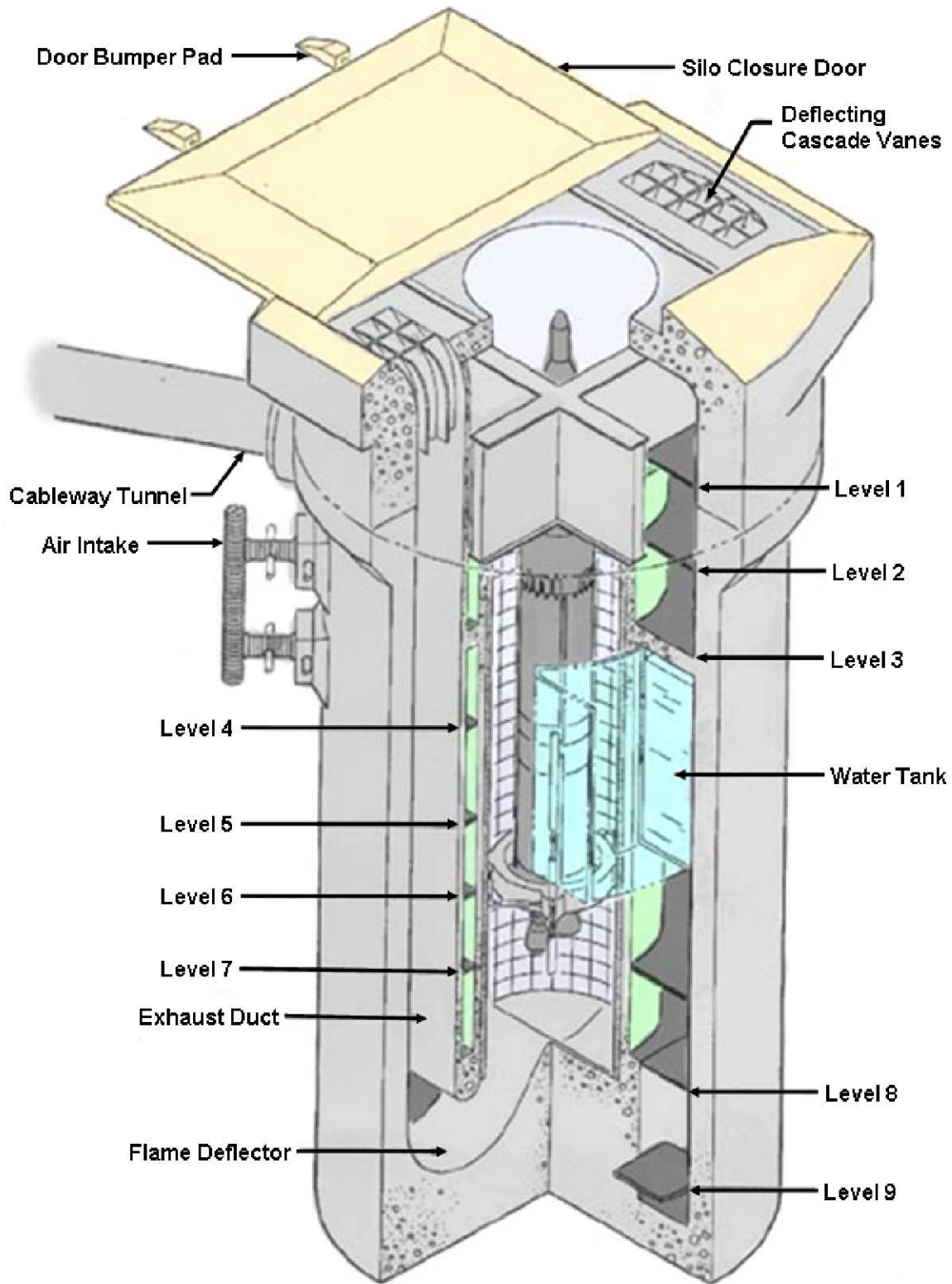

Figure 7-2: Titan II Missile Silo

References: Hartsell; Titan-II.com; Titan II Missile Explosion

8 KSC Incorrect Flight Cap N₂O₄ Vapor Release (July 1981, KSC OPF1)

On roughly July 14, 1981 in OPF1, there was an inadvertent release of N₂O₄ (NO₂) vapors during the MD338 flight cap installation procedure. The cap was removed from MD338 on June 15, 1981 and routed to another facility with a fume hood for refurbishment. During the refurbishment procedure the incorrect part number (MC276-0018-2411, a ¼-inch flight cap, see Figure 8-1 for a description of the numbering nomenclature) was recorded for the cap and a parts tag with the incorrect number was attached. The correct part number was MC276-0018-2811 (a ½-inch oxidizer flight cap, shown in Figure 8-2). There had been issues with oxidizer flight caps becoming corroded; therefore, a problem report (PR) was generated to clean the caps. During the cleaning procedure the part number that was etched onto the cap was sanded off and all that was left to identify the cap was the attached parts tag (which was incorrect).

Coupling Size (in.)	Poppet Area (in. ²)	Force to Open (lbs)	Force to Open (psid)	Poppet Travel (in.)
¼	0.709	9.50	13.40	0.034
½	1.131	14.00	12.38	0.053
1.00	2.193	14.80	6.75	0.139

MD276-0018-XXXX

- When this is a "4" the AHC tube size is ¼-inch OD
- When this is an "8" the AHC tube size is ½-inch OD
- When this is a "6" the AHC tube size is 1.00-inch OD

Figure 8-1: General Information on the MC276-0018 Air Half Coupling

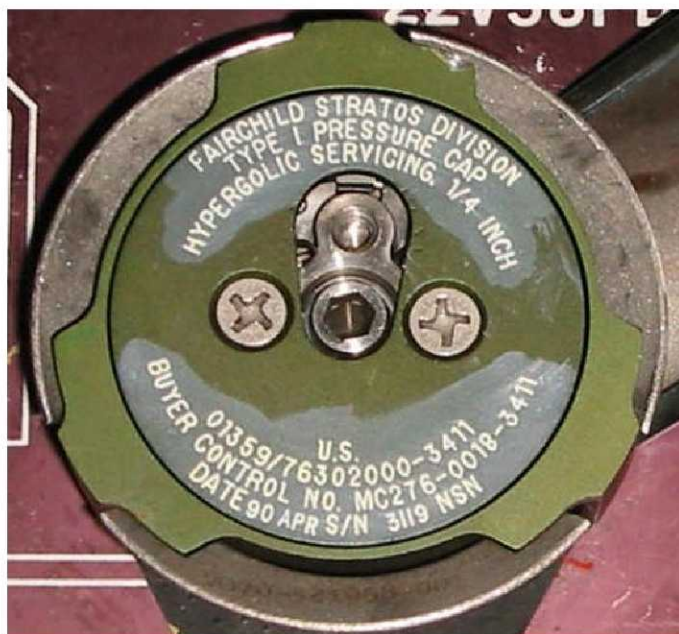

Figure 8-2: Fairchild ½-inch Flight Cap

During the MD338 flight cap installation procedure, on roughly July 14, 1981, the work step correctly called for the installation of a ½-inch cap (part number MC276-0018-2811) onto the AHC. The cap that was staged for installation was the misidentified ¼-inch cap. When a ¼-inch cap is placed onto a ½-inch

AHC, the dimensions of the stem allow for the actuation of the ½-inch AHC poppet (reference Figure 29-1 for an illustration of this) if the proper force is applied to the cap and poppet. This is exactly what happened. An oxidizer vapor release was reported when the technician tried to install the ¼-inch cap (proximate cause). The root causes are human error, improper configuration management, and improper vehicle design. The original flight cap design should not have enabled this type of incident to occur. The technician received minor injuries from exposure to NO₂ vapors. Close attention needs to be paid to the identification of flight caps and other hardware to prevent an event like this from occurring again (which it does on November 4, 1992 at WSTF).

References: Wilder (LO-JW-81-010); Craig

9 MMH Exposure Following Flexhose Removal at Pad Farm (7/14/1981, KSC Pad 39A Fuel Farm)

On the morning of July 14, 1981, a technician was exposed to MMH liquid and vapors while removing an improperly labeled GSE flexhose from a panel at the Pad 39A (Space Shuttle and Apollo Program launch pad, along with 39B) fuel farm (proximate cause). The liquid MMH sprayed onto the technician's arm and face, which he immediately attempted to wash off with water. The technician then reported to his supervisor who instructed him to wash his arm and face again, thoroughly, and formally report the incident.

Upon investigation, it was found that the flexhose that was being removed was not labeled as hazardous. Proper labeling and configuration management guidelines were not followed (a root cause). The procedure had also not received a proper review by an experienced engineer (another root cause). The engineer that had been assigned to the procedure development task had delegated it to an engineer on loan from another facility and had instructed him to process the procedure as non-hazardous. Currently, procedures at KSC require a second review by a qualified engineer for hazardous GSE and vehicle operations. The technician was very lucky the carelessness in the procedure development and flexhose labels did not result in a more severe injury.

Reference: Wilder (LO-JW-81-011)

10 STS-2 OV-102 Right Pod MMH Fire (Fall 1981, KSC OPF1)

In the fall of 1981, a small amount of MMH (approximately a teaspoon) was spilled onto the gold multi-layer insulation (MLI) blankets in the right OMS pod (RV01) of Columbia (OV-102). Technicians unknowingly opened a line that contained a small amount of liquid MMH (proximate cause of the spill). Apparently, instructions had been given to the technicians to remove the blankets and install spill protection, but this was not completed and it was not incorporated into the procedure. The gold foil of the MLI blanket acted as a catalyst while the blanket batting absorbed and concentrated the released MMH. The cause of the fire was a result of the ventilated surface area (by aspirator) creating the correct conditions for combustion of MMH (proximate cause of the fire). The batting acted as an insulator effectively containing the heat of the reaction, transferring the heat back to the MMH, and allowing the temperature to increase to the boiling temperature of MMH (189.5 °F). Ignition of the blanket followed once the vapor fumes reached the auto-ignition temperature of MMH (382 °F). A technician used nearby flame retardant coveralls to extinguish the flames.

It was later determined that MMH and gold are not compatible. The two root causes of this incident were operational human error and improper design (incompatible materials). Silver was later used, rather than gold, for thermal blanket construction. Note: in the past on other programs, the catalyst beds for mono-propellant thrusters contained gold until the material was switched to platinum. The gold was used for its high reactivity with hydrazine to support combustion in the thrusters.

Reference: Houston; Heinrich

11 STS-2 OV-102 N₂O₄ Spill (9/22/1981, KSC Pad 39A 207-Foot Level)

At 1:13 AM on September 22, 1981 an N₂O₄ spill occurred at Pad 39A. The proximate cause of the spill was a failed ground half coupling (GHC), MD162, at the AP28-12 door on FRC2 of OV-102 (Columbia). Failure of the GHC was a result of iron nitrate build-up between the probe and the dynamic head of the GHC along with the tight tolerances of the GHC. See Figure 11-1, Figure 11-2, and Figure 11-3 for a description of the AHC and GHC flow paths and also the failure location. Between 15 to 20 gallons of oxidizer was released into the attached scupper, which subsequently overflowed onto the vehicle. Damage to thermal tile adhesive resulted in the removal of 370 tiles (shown in orange in Figure 11-4). The photograph in Figure 11-5 shows the thermal tiles and the underlying vehicle structure along with the scupper and QD flexhoses going into the AP28-00 door (second FRCS oxidizer servicing door just beneath the AP28-12 door when the vehicle is in the vertical orientation).

Confusion resulted in wasted time. Immediately following the spill, the proper alarms went off at the launch pad's 207' level; however, in the Launch Control Center (LCC), the engineers on console were unaware of the spill source until there was visual confirmation from the technicians (who were located outside the FRCS room). Engineers on console executed the prewritten worksteps in the Operations and Maintenance Instruction (OMI) to safe the system once they realized the situation. Unfortunately, these steps did not include isolation of the QD from the GSE supply; therefore, the leak continued until this was noted and resolved.

The spill protection was not suitable for a large leak. It was incorrectly assumed that if a spill did occur; it would be small and containable within the spill protection. The spill protection still in use on the Space Shuttle Program over 27 years later is very similar to the "temporary" redesigned spill protection following the STS-2 N₂O₄ spill.

The launch was delayed by about one month while repairs were made to the vehicle, which remained at the launch pad. Many of the thermal tiles were baked in an oven and reinstalled onto the orbiter, which is a standard procedure to remove the N₂O₄ or NO₂ from thermal tiles when they become impregnated with oxidizer vapors. Several damaged thermal blankets located inside the forward module were replaced at the pad by accessing them through two doors adjacent to the orbiter windows.

A committee was formed to investigate the spill and compile recommendations for improvements and lessons learned. The following is a summary of the lessons learned:

- The GHC design was flawed in that there was a single point failure resulting in a leak path (a root cause)
- The scupper and apron were not large enough to contain the spill
- Using the GHC as a shut-off valve was flawed engineering practice (another root cause)
- The emergency procedure was inadequate
- All entry paths to the FRCS module should be sealed
- Care must be taken in the control of iron nitrate which is always present in an N₂O₄ system
 - Iron nitrate and its impacts to hardware were not well understood in 1981
- Proper ventilation and lighting should be added to the FRCS room on the 207-foot level of launch pads 39A and 39B
- Emergency Launch Processing System (LPS) programs could have saved time during safing
- The communications system could have been used more efficiently

Corroded structural components that had been exposed to oxidizer vapors were later found in the internal portion of the FRCS module. It is believed that the vapors entered the forward module through small test ports located at the external doors. Many years later it was also found that the oxidizer vapor reacted with several electrical connector backshells within the FRCS.

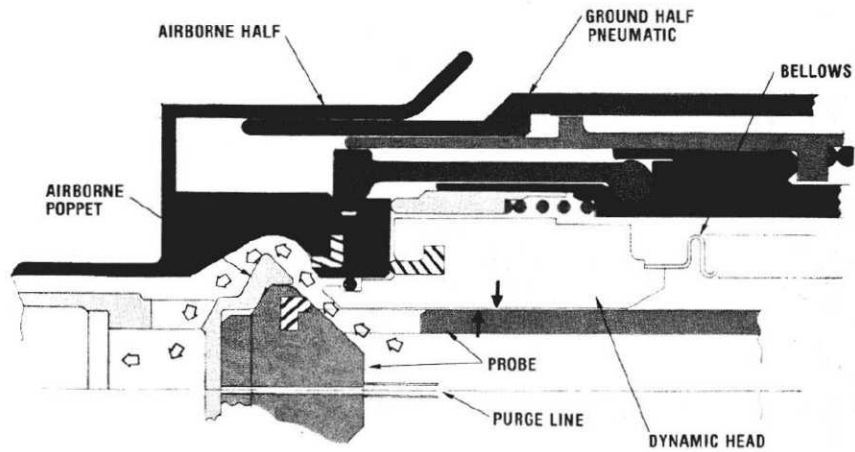

Figure 11-1: AHC and GHC in Open Position

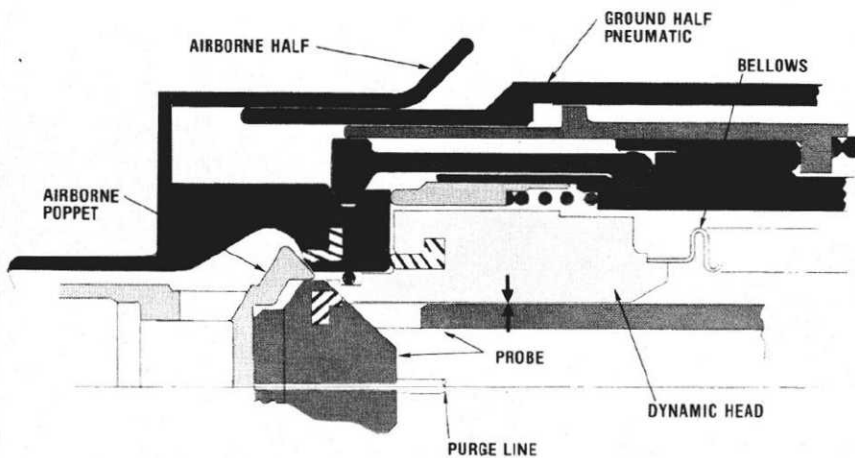

Figure 11-2: AHC and GHC in Closed Position

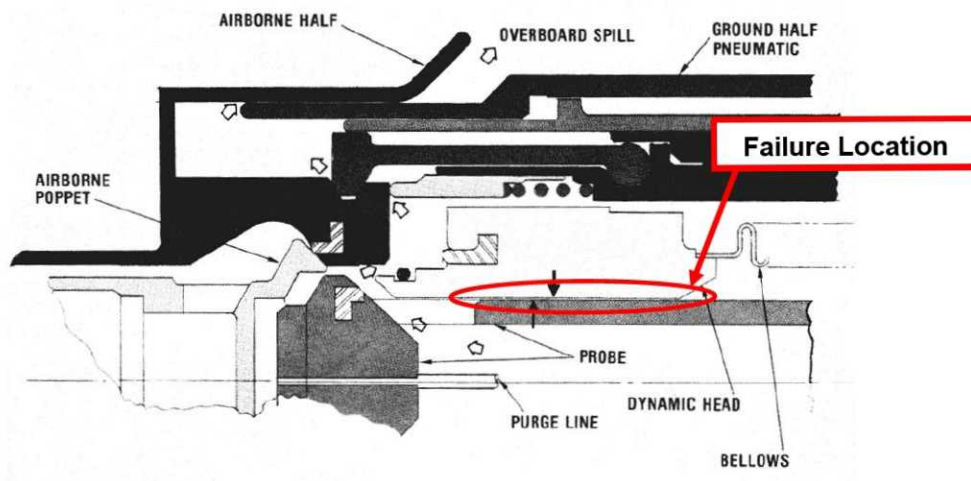

Figure 11-3: AHC Closed and GHC Failed Open with External Leak Path Shown

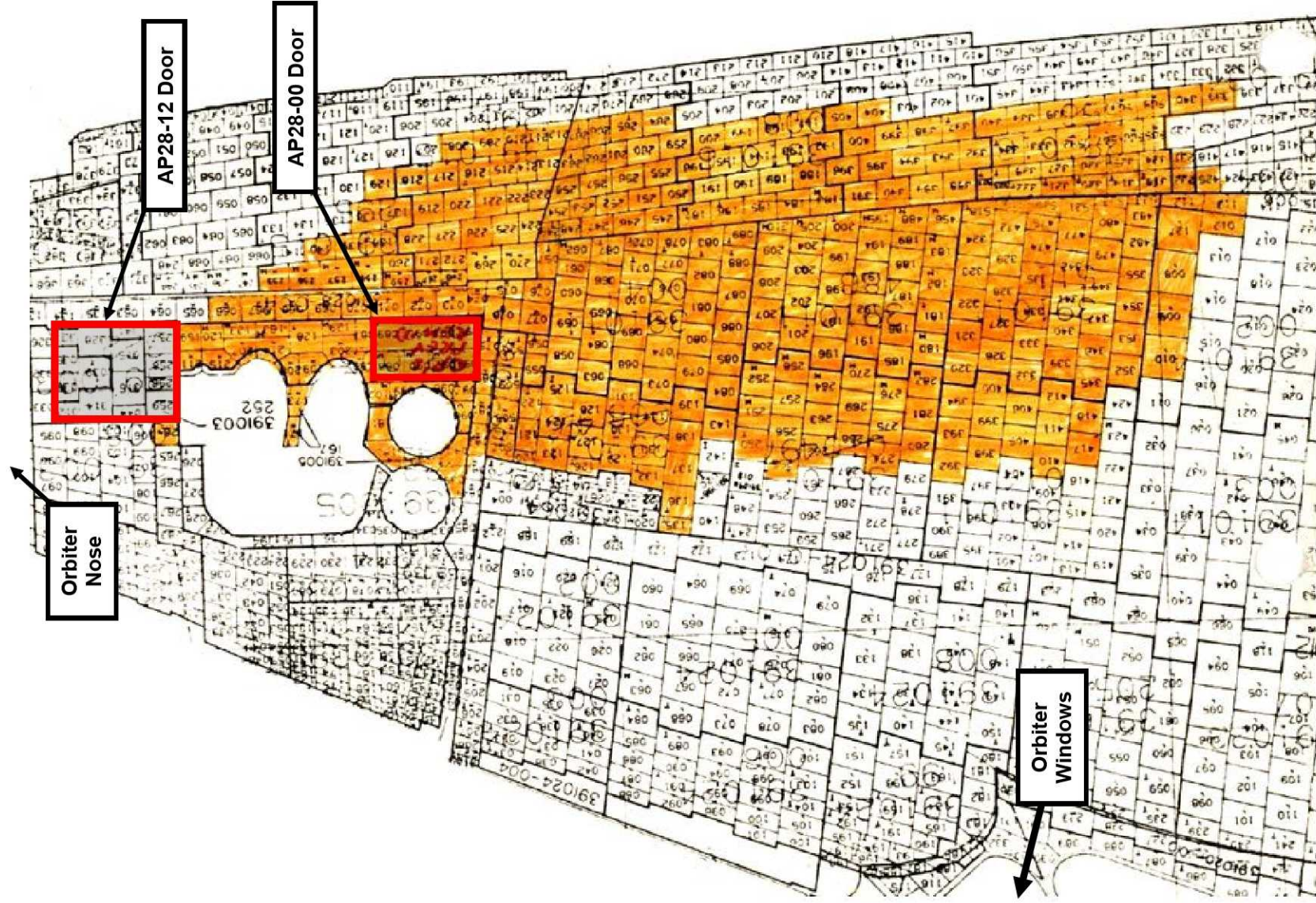

Figure 11-4: Removed Tile from OV-102 Following STS-2 N₂O₄ Spill

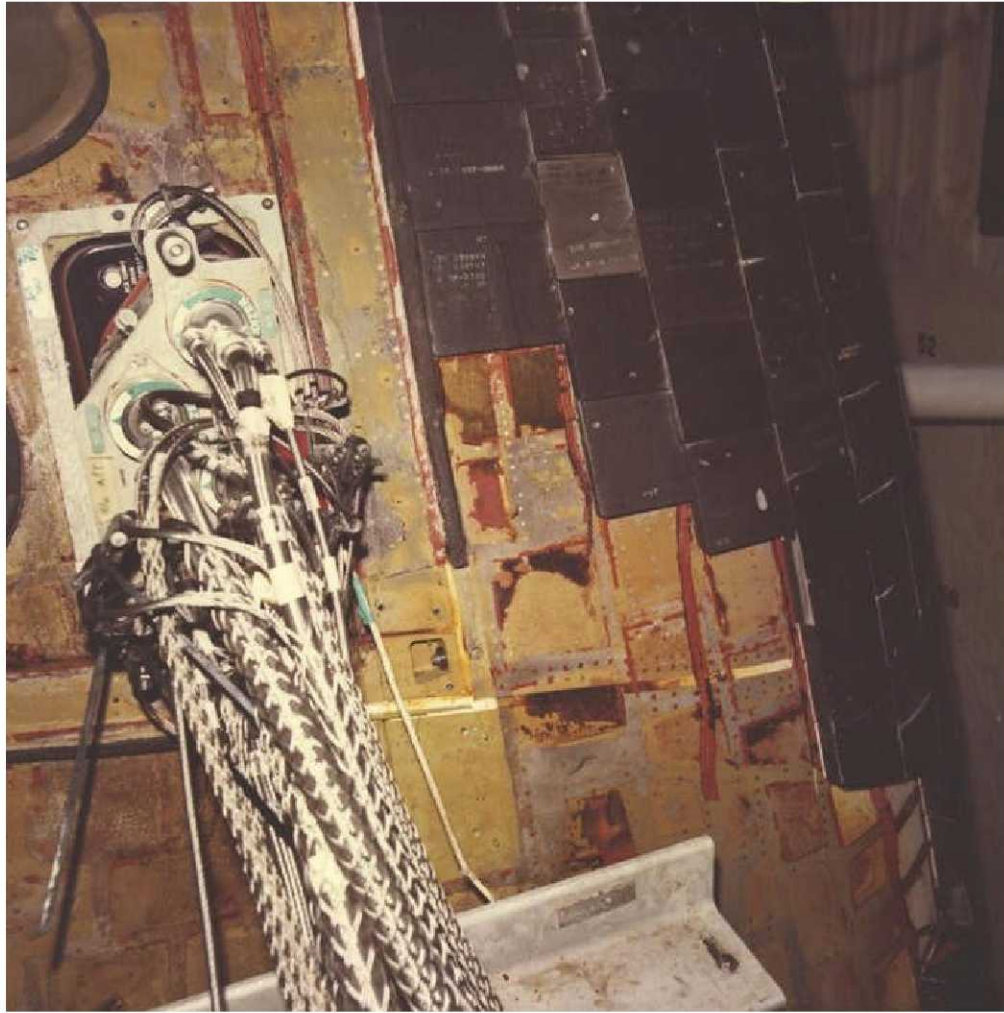

Figure 11-5: Photograph of AP28-00 Door and Orbiter Following the Spill

A large amount of knowledge was gained from the spill. There were many process and GSE design changes implemented following the recommendations from the Mishap Investigation Committee Report. The following is a list of what was completed:

- Additional GSE valves were added to isolate the liquid N_2O_4 rather than using the QDs as valves
 - GHCs were subsequently no longer used as shut-off valves during loading
- The scuppers were upgraded through a redesign
- The QDs and AHCs were found to have very tight tolerances; therefore, the poppets were subsequently electropolished to open the tolerances
- An improved maintenance plan was implemented for the GHCs
- Improved local emergency procedures were implemented
- Entry paths to the FRCS module were blocked with tape and RTV (adhesive)
- Improved controls were put in place to minimize the amount of iron nitrate in the liquid N_2O_4
- The lighting in the FRCS room was enhanced
- LPS improvements were made including automatic remote safing that was keyed from local toxic vapor detection devices

Reference: Williams; Heinrich

12 Pad 39A Fuel Farm MMH Spill and Fire Following Pneumatic Valve R&R (6/29/1982, KSC Pad 39A Fuel Farm)

On June 29, 1982 (a hot summer day with a high of 90 °F), at the Pad 39A fuel farm, there was an MMH spill and fire during the removal and replacement of a pneumatically controlled valve. Figure 12-1 and Figure 12-2 are photographs taken following the fire. Prior to the removal and replacement of the valve, the farm was powered down and the GN₂ valve control pressure was removed to enable the removal of the control pressure tubing on the pneumatic valve. When this pressure was removed, a few valves that were intended to remain closed, went to open (the valves were normally open valves with the pressure removed). This was the proximate cause. The change in valve positions went unnoticed or was ignored by the engineers on console.

Immediately following the removal of the valve a small amount of fuel vapor was released from the open line. About a minute later, a 12- to 48-inch geyser of MMH was released from the open line and splashed onto a metal cable tray above and ignited either as a result of the hot metal or by some local iron oxide (rust). It was estimated that approximately 15 to 25 gallons spilled from the line. The engineer located in the LCC could not see the events as they occurred as a result of having a view from the Pad 39A oxidizer farm camera on his closed circuit television (OTV) screen, which is located approximately 1,800 feet from the fuel farm.

The technicians reported the spill and immediately evacuated the farm to the camera embankment south of the fuel farm, removing themselves from the communications loop in the process. Once there, they awaited the SCAPE pickup van. The farm firex was then activated remotely by the duty officer, extinguishing the fire. The technicians reported that they were unable to reach the firex controls as a result of the flames. No one was injured in the spill and fire; however, there was a notable amount of damage to the GSE at the fuel farm as seen in Figure 12-1 and Figure 12-2.

Following the fire, manual overrides were added to the liquid return isolation valve and the storage tank isolation valve, which cycled normally open when control pressure was removed. Improper GSE design was one root cause of this incident. It was also found that when the 750 psig GN₂ supply pressure was vented in preparation for the valve removal, the toxic vapor aspirator lost its pneumatic supply pressure. A pneumatic actuation valve and vent valve were added to the GSE at the propellant farms to better isolate the liquid MMH and the aspirator, respectively, when removing and replacing valves. Labels were painted in large letters on the farm roofs and sides of the propellant storage tanks to aid in the identification of the farms via OTV. Other findings related to this incident include the following:

- The procedure was not written or reviewed by an experienced engineer prior to the task
- The engineer on console was making changes to the procedure real-time while monitoring another task in parallel
 - Improper adherence to the procedure and the procedure approval process are also root causes of this incident
- There was only one engineer on console supporting the hazardous operation
 - The engineer had to leave the communications channel to talk to the test conductor and in doing this missed some reports from the personnel at the fuel farm
- There was not a charged water line nearby when the fire occurred

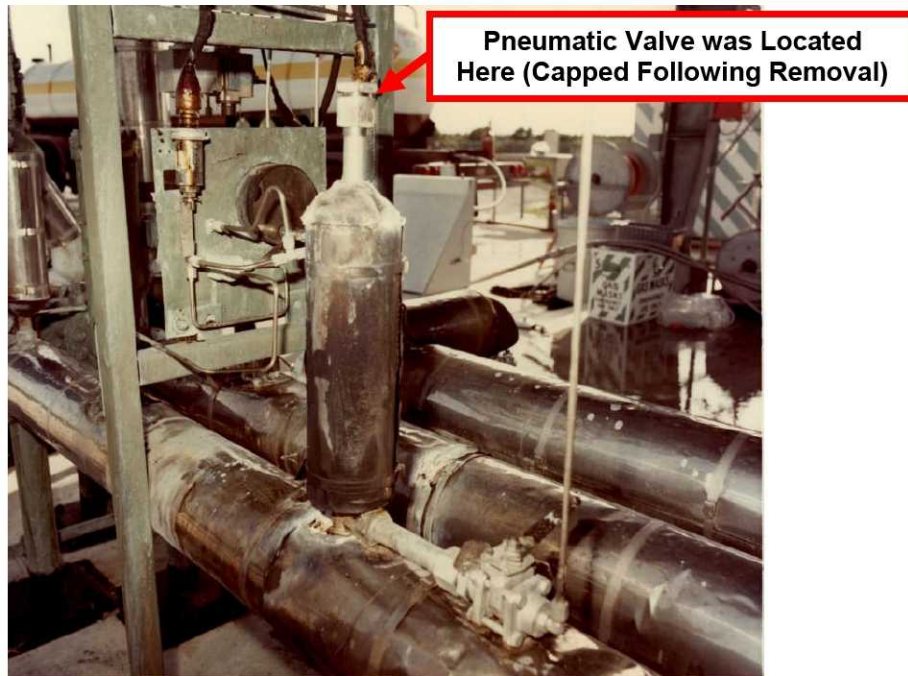

Figure 12-1: Photograph of Fuel Farm Following Fire

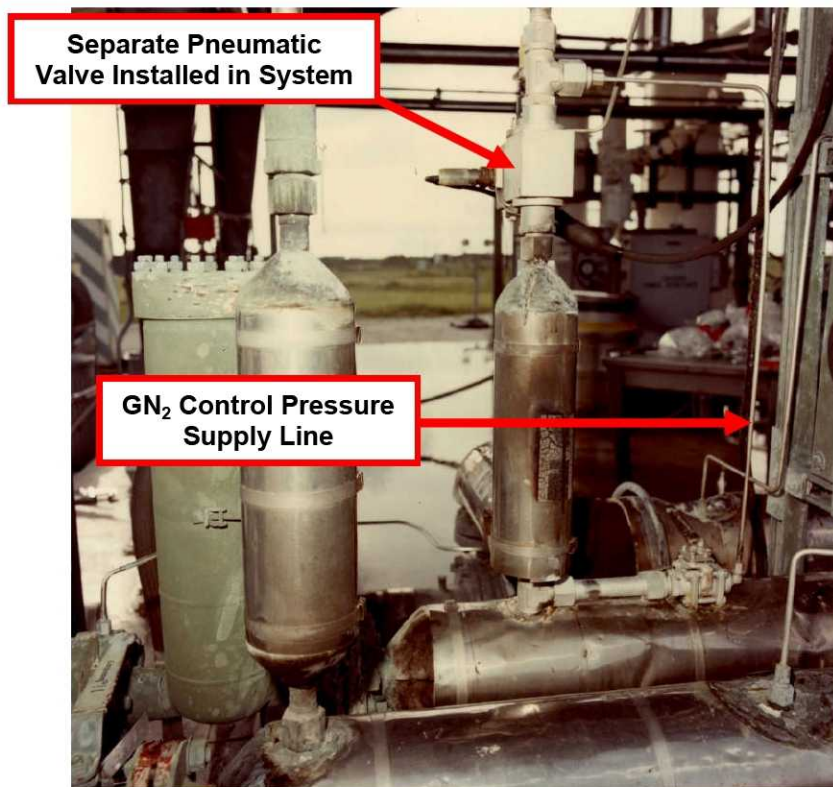

Figure 12-2: Separate Pneumatic Valve (Following Fire)

References: Tribe (L0-JT-82-044); Utsman

13 N₂O₄ Vapor Release from Flange Gasket (2/10/1983, KSC Pad 39A Oxidizer Farm)

During processing for the first flight (STS-6) of Challenger on February 10, 1983, there was an N₂O₄ vapor release at the Pad 39A oxidizer farm. Technicians and engineers were working a decay and leak check procedure on the fluid distribution system. The engineer on console was bringing up the system pressure at the farm. While this was occurring, the technicians reported a large N₂O₄ vapor release. They also later described hearing a loud noise during the pressurization. The engineer secured the GSE and reported that there was an emergency on the communications net. The oxidizer farm was cleared of all personnel and a SCAPE crew was sent in. The SCAPE technicians noted that a flange gasket on an isolation valve had blown out and was releasing N₂O₄ (NO₂) vapors (proximate cause). There were no injuries since all personnel at the farm were located upwind from the vapor release. This incident seems to have been properly managed by the technicians and engineers; however, there may have been a design flaw in the GSE, which could be considered a root cause.

Reference: Kamp

14 FRCS Ferry Plug Removal MMH Spill (4/18/1983, KSC OPF1)

On roughly April 18, 1983, during the orbiter thruster ferry plug removal operation, liquid MMH spilled from two thrusters (F4D and L1L), wetness was noted in one (R1U), and vapors were noted in another (R2D). These events occurred during turn-around operations following the arrival of Challenger at KSC via the Shuttle Carrier Aircraft (SCA) from the orbiter's maiden voyage (STS-6) and landing at EAFB. A technician was exposed to liquid fuel when the plug was removed from F4D (FRCS down firing thruster on manifold four). It was estimated that ¼ to ½ of a cup spilled from the thruster.

The liquid presence in the thruster chambers was likely a result of the fuel pilot operated valves leaking. These valves are sensitive to temperatures below 60 °F because the Teflon seals non-uniformly contract. Normally, the temperature was maintained above 60 °F using the thruster heaters; however, when the SCA and orbiter landed at KSC, the orbiter was not powered for about 36 hours. During this time period, the outside temperature dropped to a low of approximately 50 °F and remained below 60 °F for about nine hours. The following are lessons learned and corrective actions that were implemented following this incident:

- Thruster heaters shall remain on during all ferry and post-landing orbiter operations
- Ferry plug removal was upgraded from the current PPE level at the time to a SCAPE operation
- The ferry plug relief valve shall be aspirated with the fuel aspirator prior to ferry plug removal
 - If there is any indication of oxidizer at the relief valve exit, the oxidizer aspirator shall be used for this operation

The proximate cause of this incident was removing a thruster ferry plug without knowing that there was liquid fuel present behind it. The root cause was an improper operational understanding of the limitations and sensitivities of the thruster fuel valves.

It was also noted in the corrective actions memo written by Mr. Tribe that it is less likely that the oxidizer thruster valves would leak since the Teflon seals swell by approximately 3% when exposed to N₂O₄ at ambient temperature. The seals only swell by approximately 0.7% in the presence of MMH at ambient temperature.

Reference: Tribe (L0-JT-82-043)

15 STS-9 OV-102 APU-1 and -2 Explosion (12/8/1983, EAFB Runway 170)

On December 8, 1983, Space Shuttle Columbia landed at EAFB at 3:48 PM pacific local time, concluding the STS-9 mission. About seven minutes after landing, an unusual series of events occurred. First, APU-1 shut down prematurely in response to a sensed turbine "underspeed" condition. About four and a half minutes later an explosion occurred in the APU. Figure 15-1 shows what remained of the APU-1 fuel pump following the explosion along with the resulting collateral damage. At the instant of the APU-1 explosion, APU-2 spontaneously shut down. Fifteen minutes later it exploded. Figure 15-2 is a photograph of APU-1 and APU-2 in the aft of OV-105 (similar to the OV-102 configuration). APU-3 ran nominally.

Failure analysis indicated that stress corrosion cracking of the injector tube created the leak into APU-1's gas generator cavity (proximate cause). In the vacuum of space, the hydrazine froze in the cavity and remained stable throughout the orbital phase of the mission. However, when the vehicle started its re-entry, the hydrazine thawed, expanded, vaporized, and then eventually caused the gas generator to explode. The following is quoted from the Space Shuttle Mission Evaluation Room (MER) database:

"Post-flight data review indicated that hydrazine leakage first occurred approximately 17 minutes after APU-1 and -2 were started for entry. This condition was indicated by valve-module cooling caused by hydrazine evaporation. The hydrazine accumulated in an ice state between the valve-mounting plates and the gas-generator radiation shield. As entry continued and the lower altitudes were reached, flash evaporation ceased, melting began, and the liquid hydrazine ran down on to the hot turbine housing surfaces. The ambient pressure in the aft fuselage reached a level that would support decomposition at approximately 4 minutes and 30 seconds prior to landing. Hydrazine decomposition and subsequent release occurred as indicated by valve module heating approximately 4 minutes prior to landing for APU-1 and 2 minutes prior to landing for APU-2. Numerous instrumentation and electrical wires on both APUs were damaged by fire. The APU-1 shutoff valve electrical current was interrupted, closing the modulation valve which caused an APU underspeed condition. The system fuel isolation valve also closed, automatically isolating the APU-1 fuel supply. Residual heat from the fire, combined with normal heat soak-back, caused the modulation valve and associated tubing to overheat to approximately 500 °F. The trapped hydrazine explosively decomposed and the APU-1 modulation valve detonated. The detonation caused the APU-1 high-point bleed quick-disconnect poppet to be expelled through the flight cap and sent shock waves up the fuel line which detonated fuel vapor bubbles in the fuel pump cavity. Additional hydrazine was sprayed into the aft compartment at the time of APU-1 detonation as indicated by the splash pattern on the avionics bays. Apparently, the shockwave from the APU-1 detonation caused the already damaged wires on APU-2 to short, closing the modulation valve causing APU-2 to shut down. This resulted in an automatic isolation valve closure which isolated the APU-2 fuel supply. The residual heat from the fire combined with the normal heat soak-back to cause the APU-2 modulation valve to detonate resulting in a high-point bleed quick disconnect blow off and a subsequent fuel pump detonation.

Inspection of the aft compartment at the APU-1 location revealed minor hydrazine splash in the area of the APU mounts and on top of the avionics bays. There was smoke and heat discolorations on the insulation and structure forward of the APU and on the exhaust duct above the APU. Minor shrapnel damage was noted.

APU-2 had a splash pattern similar to APU-1, except more extensive. The smoke and heat discolorations were evident to a greater degree than on APU-1 and at locations higher above the APU. Also, minor shrapnel damage was noted.

The tear-down and inspection of both APUs revealed that the damage was similar and limited to the fuel systems and wiring. Further inspection of the APU injector tubes revealed that both tubes were cracked circumferentially upstream of the thermal shunt.

The APU stems had intergranular cracks from the inside diameter to the outside diameter for 225 degrees on APU-1 and 180 degrees on APU-2 around the circumference of the stems. All microstructure indicated intergranular carbide precipitation at the inside diameter. The most probable scenario describing the cause of the APU stem failure is as follows:

During the manufacturing operations (braze cycle), a slow cooling of Hasteloy B, which is the APU stem injector material, from 2100 °F to 1100 °F resulted in carbide precipitation at the material grain boundaries. Additional carbon believed to be available from electro discharge machining of the stem bore diffused into the alloy during the brazing operations. A variance in cooling rate between the inside diameter and outside diameter during the braze cycle caused enhanced carbide precipitation near the inside diameter. The resultant microstructure was sensitized, which means that the corrosion resistance of the grain boundaries was reduced. The sensitized surface contacted an aggressive environment (hydrazine, air, moisture, carbon dioxide, ammonia) with attack accelerated at a region-of-stress concentration due to sustained stress levels (injector stem preload caused by manufacturing assembly misalignment). The crack progressed until stress levels and/or availability of corrodant changes allowed the fracture to finish under mechanical or thermal fatigue conditions. The most suspicious corrodant is carbazic acid. The above scenario is considered to be time dependent. The failure mechanism is thought to be stress corrosion which requires a susceptible material, an available corrodant, and the presence of a sustained surface tensile stress level.

The APU failures most probably resulted from a crack in the injector stem caused by corrosion of the sensitized inside diameter surface. The corrodant is probably carbazic acid or some similar substance which can be derived from air, moisture, CO₂, hydrazine and/or ammonia. The corrosion is time dependent and the crack progressed under sustained stress levels from the inner diameter surface toward the outer diameter surface until mechanical or thermal fatigue conditions could [complete] the crack rupture.”

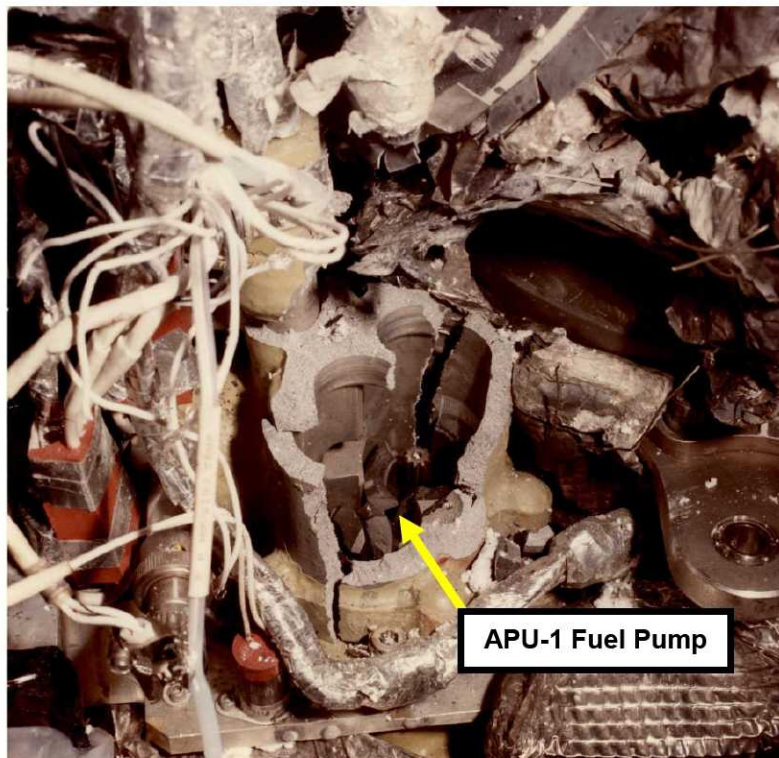

Figure 15-1: APU 1 Fuel Pump Explosion Following STS-9

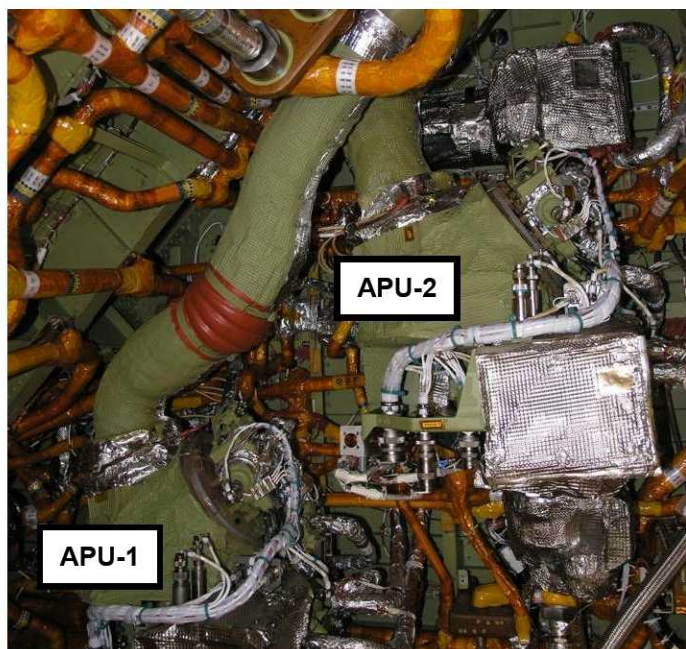

Figure 15-2: APU-1 and -2 in a Nominal Configuration

Following the STS-9 flight, several changes were made to the APU subsystem, including soaking of the carbon seals in hydrazine prior to installation, chromizing the injector stems to prevent corrosion, and minimizing stresses on the injector stems during manufacturing and installation. These design flaws are believed to be the root causes of the incident.

Reference: MER Problem Report (STS-9) STS-9-V-26

16 N₂O₄ Vapor Release from Loose Fitting (2/17/1984, KSC OPF2)

On February 17, 1984 there was a small N₂O₄ vapor release from a loose B-nut fitting in the GSE oxidizer vent line in OPF2. There were no injuries or hardware damage; however, OPF2 was evacuated as a precaution. It was found that the contractor who originally installed the hardware was careless in their installation of several fittings, which were improperly torqued (proximate cause). Once OV-099 rolled out for flight from the OPF, all hypergolic, ammonia, and Freon vent system fittings were re-torqued and recorded. It was also found that butyl rubber o-rings were installed into some fittings. Butyl rubber is not compatible with N₂O₄. Following a detailed review of engineering drawings and historical records, all suspect fittings were removed and fittings with Teflon seals were installed. Improper configuration management was the root cause of this incident.

The actual incident was not that noteworthy, but there were several improvements made to the GSE, configuration control and management, contractor oversight procedures, and OPF area warning system. It was found that there was not a proper system in place for a single bay evacuation (OPF1 and OPF2 are connected). The single bay clears to date had all been conducted through the area paging system, which most personnel in the processing bay either cannot hear or tune out as a result of the large quantity of pages that do not concern them. It was also discovered that once the bay had been cleared that it was impossible to know if everyone was out of the building. These two items resulted in an OPF area warning system with audible alarms (also known as "warblers") and flashing lights along with the addition of a badge board outside the entrance to the bay where personnel are required to place their KSC badge prior to entering. This was a substantial improvement in safety. With the new area warning system, personnel were able to be notified in the case of a single bay evacuation or dual-bay evacuation. Also, following this

incident, there was a strong emphasis placed on detailed contractor surveillance. Prior to the vapor release, outside contractors were allowed to install hardware without proper procedures and oversight.

Reference: Bowman

17 CCAFS Tanker MMH Fire (5/16/1984, CCAFS FSA 1)

On May 16, 1984, at Fuel Storage Area one (FSA 1) on CCAFS there was an MMH fire during a tanker offload operation. The 3,000 gallon tanker was being drained of its MMH to prepare it for transport of Aerozine-50. Approximately 60 gallons had been drained from the tanker into the facility storage system while the tanker was at a pressure above atmospheric. The tanker was then purged with GN₂ and vented to ambient to allow the technicians to disconnect a flange in the tanker sump (the tank's low point). The flange removal opened the tanker to atmosphere for gravity draining of the residual MMH (about one to two gallons) into a stainless steel bucket below, which was being held by one of the technicians. When the flange gasket came loose from the tanker, the two technicians noticed the presence of heat on their hands and arms through their SCAPE suit gloves. One SCAPE technician declared that there was a fire over the communications network and on his way to the safety shower he activated the facility water deluge system.

Once the SCAPE personnel were sure they had extinguished the flames on their suits, they evacuated the area to the south. Both had received minor burns on their hands and were sent to a medical facility. It was later noted that both SCAPE suits showed signs of burning when they were examined following the incident. Shortly after the technicians entered the showers, two fire and rescue personnel who were waiting on standby, entered the area and aided the water deluge in extinguishing the flames with their charged hoses. It was reported that the fire was completely extinguished in about one minute.

Following the incident, there was an extensive inspection of the tanker and surrounding areas. It was found that the fire was mainly concentrated around the shroud, which covered the sump flange, and the stainless steel bucket. An exact cause of the fire was unable to be determined; however, several possibilities exist. The following is a tabulated list of possible causes of the fire:

- There was an extensive amount of corrosion (iron oxide) around the sump drain flange
- The bucket was not properly inspected and cleaned of any possible iron oxides or other contamination prior to running the procedure
- The bucket could have heated up from solar radiation (the weather for May 16, 1984 was a high of 80 °F and a low of 69 °F)
- There was a potential for a static charge buildup from the falling column of liquid
 - It was reported that the tanker was grounded properly
 - The stainless steel bucket used to drain the residual amount of MMH was not grounded
- There was non-compatible rust-proofing undercoating on the wheel fenders of the tanker
- The method of the flange removal was suspect
 - One bolt was left in the flange allowing it to rotate out of the flow path freely while spraying MMH in a fan-like pattern increasing the surface area wetted by liquid MMH and introducing large amounts of MMH vapor into the air

It is unknown whether the fire started on the tanker structure or in the bucket. The SCAPE technician did state that he did not feel the heat on his hands until after the residual MMH had been emptied from the tanker into the bucket. Draining of fuel without knowing that an ignition source was present was the proximate cause of the incident. Improper configuration management (maintenance of the hardware to prevent the buildup of rust) and an improper training of personnel (flange removal) are noted as the root causes of this incident. Following the fire, improvements were made to the fuel storage area water deluge system and the fuel tanker trailers. More safety showers were also added to the storage area.

References: McCoy; Washburn

18 Liquid Trap in Purge Adapter Flexhose MMH Spill (5/24/1985, KSC OPF1)

On May 24, 1985, while preparing for the removal of R4D (down-firing thruster on the Space Shuttle right pod) from OV-099, there was an MMH spill in OPF1 on the 10-foot level west side. R4D was being removed as a result of an in-flight anomaly related to a heater failure on the thruster. The manifold had been drained of its propellant and it was thought that a purge through the MD348 line (which connects to the manifold) and out the thruster nozzle purge adapter was sufficient to remove the liquid and most of the fuel vapors. Figure 18-1 shows a purge adapter in a cutaway of a primary thruster nozzle. During the part of the procedure where the purge adapter was being removed, approximately one cup of liquid MMH spilled from the thruster and down onto the body flap (which is illustrated relative to thruster R4D in Figure 18-2). The body flap was partially covered with spill protection sheets. The OPF1 hypergol exhaust fans were activated and the facility was immediately evacuated. It was recorded that some of the liquid MMH had saturated the body flap tile filler bar. It is unknown if the tile had to be removed. Unlike N_2O_4 , which was known to breakdown Koropon primer (from the STS-2 N_2O_4 spill mentioned previously), the effect of MMH on Koropon was not well known in 1985.



Figure 18-1: Space Shuttle Thruster Chamber Cutaway with Purge Adapter Installed

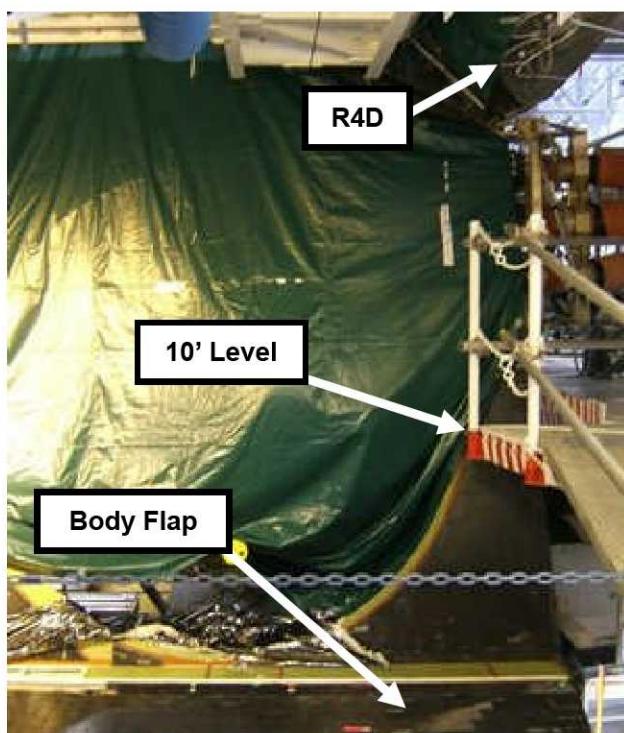

Figure 18-2: View of Bottom of Right Pod with Orbiter in OPF

There are three possible proximate causes to this spill. A combination of two or more of the following causes is also possible. The first involves an improper configuration in which the flexhose that was being used for the procedure had previously been utilized for a similar operation on the left pod thruster L1U's manifold. This flexhose was several feet longer than the flexhose that was normally used for the right pod manifold evacuations. It was routed from the R4D thruster purge adapter to the 19-foot level above, then down to the eductor on the 10-foot level. This excessive length in hose may have allowed for a "u-shaped" low point trap to be formed in which liquid MMH could have collected. The second possible proximate cause involved a procedural error made by the engineers on console. The evacuation could have created a pressure differential across the liquid MMH. When the eductor was deactivated and removed, this pressure differential may have pushed the liquid into the thruster chamber. The third possible proximate cause was the liquid had collected in the thruster chamber (see Figure 18-1) and the purge was of insufficient duration to remove all the liquid MMH or the liquid trap may have prevented the vacuum source from evaporating all the residual fuel that remained around the purge adapter. A definitive proximate cause was never determined.

Eight personnel in the area of the spill received minor injuries from the inhalation of MMH vapors. Following the spill and cleanup, the thruster was successfully removed at KSC, sent to and repaired by the manufacturer (Marquardt Corp.), and then reinstalled in the same location on the right pod of OV-099.

It appears that this spill could have been prevented if the proper hardware had been chosen for the procedure. Items of this nature should, ideally, be addressed in the written procedure. Part numbers, purge specifics, and toxic vapor check (TVC) sampling techniques should have been specified for the operation. Improper procedure control and authoring are the root causes of this incident.

References: KSC SSP PRACA Database (RP01-9-08-0031); 1985-144-00001; Heinrich

19 STS-61C OV-102 SRB HPU Loading N₂H₄ Spill (12/8/1985, KSC Pad 39A MLP Surface)

On December 8, 1985, approximately three gallons of N₂H₄ spilled from a Leer-Romec AHC on the SRB HPU system. It was later found that the AHC nipple was unthreaded from the AHC body because the nipple-to-cap threads had seized. Therefore, the technician in SCAPE was spinning off the GHC/AHC assembly from the propellant line that was online to the HPU propellant tank and bulk propellant rather than unthreading the GHC from the AHC (proximate cause). There was not a fire and the orbiter (Columbia) was undamaged. The SRB was also undamaged. Most of the liquid fell into the flame trench about 75 feet below. The N₂H₄ that collected on the MLP surface was wetted with a fine spray of water shortly after the spill. The high temperature for December 8, 1985 was 72 °F. If the temperature had been much greater and/or any rust was present on the hot mobile launch platform (MLP) surface, ignition of the hydrazine would have been more probable. At the time of the spill, Challenger was on Pad 39B awaiting the launch for STS-51L. The first flight of the Space Shuttle with the AHC anti-rotation devices installed on the SRBs was the STS-26R return to flight mission after the Challenger disaster. Improper vehicle design is the root cause of this incident.

Reference: KSC Hazard Report (SPC-K13167-86 Rev. B)

20 Inadvertent Dry Well Removal MMH Spill (1/21/1986, KSC Pad 39A Fuel Farm)

On January 21, 1986, a technician removed a temperature transducer dry well assembly from the three-inch MMH return line at the Pad 39A fuel farm. This was followed by a 12-foot high geyser of MMH from the open three-inch line. MMH contacted the left side of the technician's face and his left forearm. He went immediately to the safety shower then onto a local hospital once he was evacuated. He was diagnosed with 1st degree chemical burns on his face and 2nd degree chemical burns on his forearm. It was estimated that approximately 100 gallons of MMH liquid and/or vapor was released. The seven technicians located at the fuel farm (some completing other unrelated tasks) immediately evacuated the

area. Moments later, two technicians reentered the area from an upwind direction to activate the fire deluge system. It is very likely that this prevented a large fire. The technicians did not know that the deluge system could be remotely activated from the LCC by contacting them over the Operational Intercommunication System (OIS) or by calling 911. A fire would have likely occurred immediately if the temperature had been a normal Florida summer day; however, it was mid-winter and the outside temperature was 63 °F.

This incident took place during an annual calibration of temperature transducers and other components, using an OMI. The technician was correctly informed by the engineer on console to remove a specific temperature transducer from the MMH return line. The technician mistakenly removed the dry well and temperature transducer assembly (shown in Figure 20-1) rather than the temperature transducer alone (proximate cause). If the temperature transducer was removed properly, there would not have been a spill. The following is a quote from the mishap report that explains the incident:

“The LSOC hypergolic mechanical technician actually performing the task of transducer removal used incorrect shop practice and loosened the wrong nut. Instead of using a one-inch wrench to retain the dry well in place while loosening the transducer lock nut that threads into the dry well, he used the wrench to loosen the dry well. He then used his hand to unscrew the transducer thinking he was extracting the transducer from the dry well while he was actually unscrewing the transducer dry well assembly from the three-inch MMH line. A mixture of fluid and vapor MMH immediately erupted from the line sending a column 10 to 12 feet in the air.”

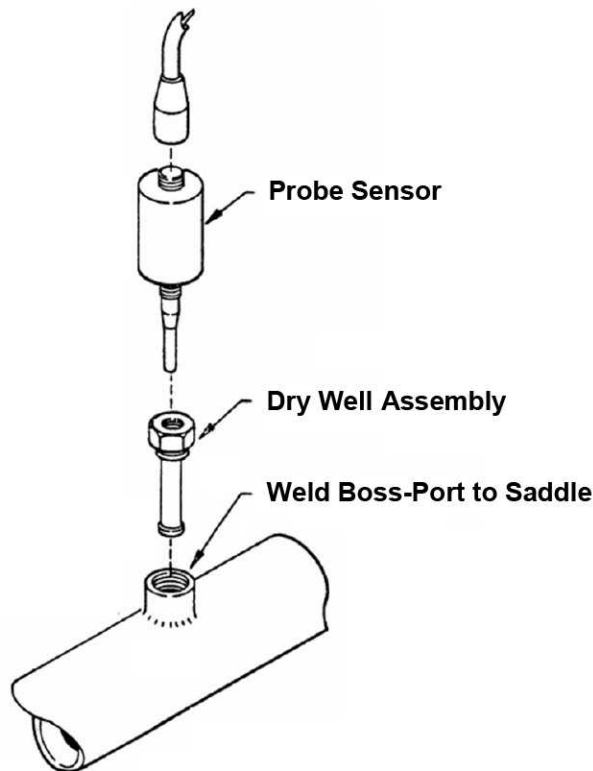

Figure 20-1: Transducer and Dry Well Assembly

Later the engineer on console told technicians to empty the drainage sump at the fuel farm. This ultimately led to contamination of a large area of standing water around the fuel farm.

It can be stated that this incident should have never happened because the GSE should have been vented and drained of all the residual MMH; however, the inherent design of the dry well assembly was to

prevent breaking into a hazardous system thus allowing for a reduced level of PPE and risk of an incident. Granted, the design of the dry well could have been improved by adding a retainer to prevent the entire transducer and dry well assembly from being removed together (a root cause). The primary root cause of this incident was lack of training of technicians. Engineers have to depend upon technicians to make the correct decisions at some point; otherwise the controls to prevent an incident (in attempt to reduce the risk to nearly zero) become so cumbersome that they hinder the actual operation, let alone the additional cost of such controls. This is a good example of a case in which engineers had to make a judgment call as to the level of PPE and system configuration. With the dry well design in mind, the judgment call appears to have been valid.

There were many lessons learned from this incident. These include:

- Dry well retainers are needed and are now used on all hypergolic propellant dry wells
 - This design flaw in the GSE is considered a root cause
- Training of technicians for proper removal of components needs to be scrutinized
 - This is considered the root cause
- The system tubing was not properly vented to ambient prior to the spill resulting in a 6 psia driving pressure behind the liquid MMH (a proximate cause)
 - Hypergol systems are usually left with a blanket pressure to prevent air intrusion and should not be required to be vented for this type of transducer replacement
- The system tubing had not been completely drained prior to running the transducer replacement operation (a proximate cause)
 - Draining of residual propellant should not be required for a transducer replacement as a result of the dry well
- The procedure was considered non-hazardous; therefore, the PPE was not at a level in which one would don for entry into a hazardous system
 - It was believed that the hazardous system would not be compromised by removal of the transducer
- Proper testing of the spill area for contamination should be completed prior to emptying the sump tanks to grade

References: Cotton; Sargent; 1986-021-00001; Heinrich

21 Relief Valve R&R Oxidizer Farm N₂O₄ Vapor Release (7/29/1986, KSC Pad 39A)

On July 29, 1986, there was a large N₂O₄ (NO₂) vapor release from the storage tank at the Pad 39A oxidizer farm. The event was somewhat planned; however, it was not anticipated that the final quantity of the release was going to be as much as what occurred. Prior to 1986, when the storage tank relief valve was required to be removed and replaced annually, it was accepted that there was going to be a release of approximately one gallon of N₂O₄ (NO₂) vapor as a result of the removed relief valve tubing being online to the storage tank ullage and open to atmosphere. The estimated vapor release following the removal of the relief valve in this instance was approximately 28 gallons.

Prior to the relief valve removal, the oxidizer storage tank was vented down. Removal operations began immediately following the venting; therefore, the propellant in the storage tank was not given the proper time to cool to below vapor pressure. There was still approximately 5 psig of pressure in the storage tank (which was visible from the remote console in the LCC) at the time of the valve removal (a proximate cause).

Another proximate cause of the larger-than-expected release was the tearing of a SCAPE technician's suit. He was trying to install the new valve while the storage tank was violently venting oxidizer vapors (as a result of the large backpressure that remained in the storage tank), when his suit brushed against a nearby sharp object. He proceeded to leave the area when he noticed the tear in his suit. This delayed the installation of the new relief valve until a new group of SCAPE technicians arrived at the oxidizer farm. It was reported that the cloud "exceeded the pre-designated clear area of 700 feet downwind" exposing

several personnel to the toxic vapors. The venting oxidizer vapor eventually cooled the liquid in the storage tank from the boil-off. This significantly decreased the violence of the heavy vapor venting.

Along with the first technician who tore his SCAPE suit, two other technicians were exposed to oxidizer vapors. One noticed yellow stains on his undergarments following the removal of his SCAPE suit. The other reported burns on his right hand later in the day. All the exposed technicians were sent to the KSC Occupational Health Facility (OHF) and released back to work within a few hours.

An improper GSE design and operational human error were the root causes of this incident. About ten months prior to this relief valve removal and replacement operation, a formal request had been submitted by engineering to install a dual relief valve system onto the storage tank with a three-way isolation valve to prevent a vapor release during component removal. This request was denied. Following the large vapor release, the modification was implemented at both launch pads, greatly reducing the possibility of any future hazard. This dual relief valve modification allowed for isolation during the relief valve annual maintenance. The modification was also implemented on the fuel storage tanks at both launch pads. Figure 21-1 is a photograph of the relief valve locations on the top of the N_2O_4 storage tank with a close-up photograph of the relief valve three-way isolation valve modification.

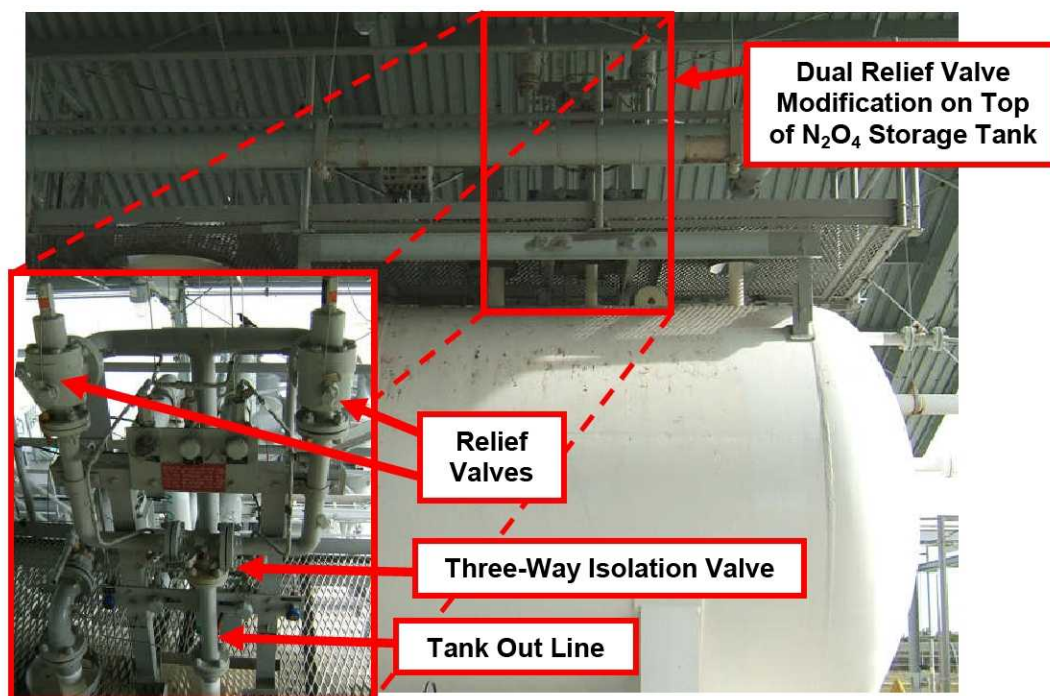

Figure 21-1: Dual Relief Valve Modification Location

References: KSC Hazard Report (SPC-K12186-85); 1986-210-00001; Heinrich

22 OPF2 Trench N_2H_4 Spill and Fire (9/19/1986, KSC OPF2)

During an APU hydrazine (N_2H_4) tank drain on September 19, 1986, there was a spill and fire in the OPF2 water deluge trench. The fire was caused by a small amount of hydrazine (about $\frac{1}{2}$ gallon) leaking from a fitting in the GSE vent system into the deluge trench and reacting with debris or residual chemicals (proximate cause). The fire was isolated to the trench. The SCAPE technicians extinguished the flames using a nearby fire hose.

Improper configuration management was the root cause of this incident. After the fire, it was found that an o-ring was missing from the outlet adapter fitting at a check valve in the vent system allowing an

external leak. It is assumed that the vent system was free of residual propellants since it was purged at 35 psig; however, since the vent had been utilized during the drain, some residual fuel remained in the lines. The following is a list of observations related to this incident:

- Cleanliness levels in the areas surrounding hypergolic operations must not be ignored
 - The OPF water deluge trench was not routinely cleaned or inspected
- The toxic vent system was not leak checked routinely; however, vent systems are not usually leak checked because they cannot be completely pressurized
- Care needs to be taken when installing components in hypergolic ground support equipment

Reference: Johnson

23 N₂O₄ and Insulation Adhesive Small Fire (6/23/1988, KSC Pad 39B Oxidizer Farm)

On May 25, 1988, at the Pad 39B oxidizer farm, technicians were completing an N₂O₄ sampling operation. During the operation, the technicians detected a small leak at the interface between the sampling valve and the tubing (see Figure 23-1). The sampling operation was delayed until the leak could be fixed. The repair was finally scheduled to be worked about a month later during the afternoon of June 23, 1988. The removal of some local insulation was required to fix the leak along with re-torquing the fitting that connected the sample valve to the tubing. This was all completed that afternoon.

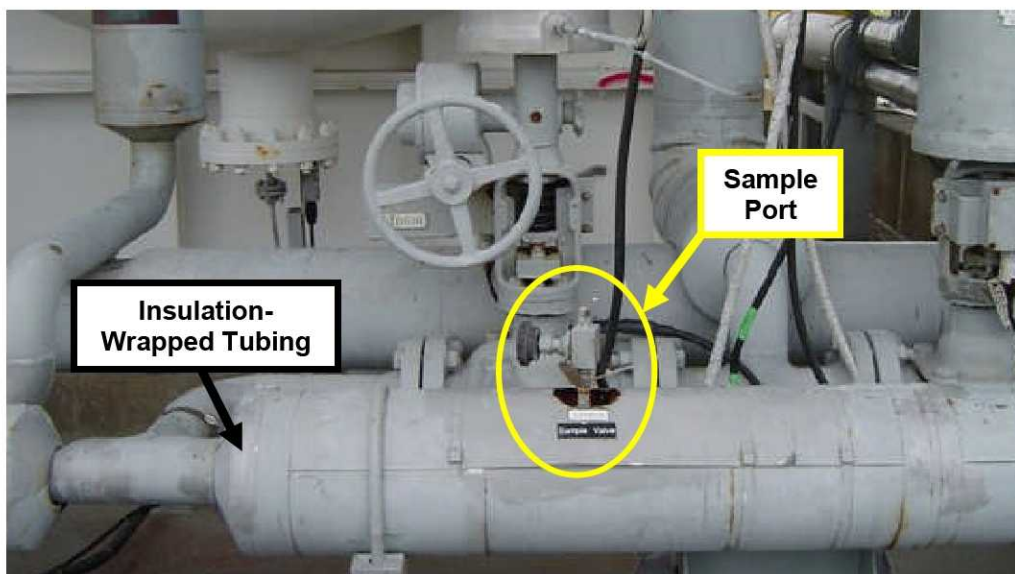

Figure 23-1: Photograph of Sample Port

At about 10:30 PM on June 23, 1988, the sampling operation was successfully repeated. This was followed by the disconnection of the sampling flexhose from the sample port. When the flexhose was removed, liquid N₂O₄ spilled (about two tablespoons) into the small well surrounding the sample port. It was not uncommon to have a small amount of residual N₂O₄ remaining in the sample flexhose when it was disconnected. The spilled N₂O₄ reacted with the adhesive used for the attachment of the insulation to the tubing and ignited (proximate cause of the fire). The fire burned itself out in about 10 to 15 seconds before the technicians in SCAPE could return with a fire hose. There were no injuries to the personnel working the operation and the only hardware damage was to the insulation, which was replaced.

The insulation had been installed within hours of the sampling procedure; therefore, it was not given the appropriate time to fully cure. The adhesive used to attach the insulation to the tubing was found to

contain volatile hydrocarbons. This allowed for a chemical reaction to take place between the adhesive and N_2O_4 , causing ignition. The root cause of this incident was operational human error as a result of not allowing the insulation adhesive to fully cure.

Reference: KSC SSP PRACA Database (PR PADB-0209)

24 STS-26R OV-103 N_2O_4 Tubing Leak on Vehicle (7/14/1988, KSC Pad 39B)

On July 14, 1988, about three days after the loading of N_2O_4 onto Discovery at Pad 39B for the STS-26R Return to Flight mission, a small N_2O_4 (NO_2) vapor leak was detected in the left OMS pod (LP04) of Discovery. STS-26R was the first flight following the Challenger disaster on January 28, 1986. The leak did not result in any injuries or hardware damage, but it did impact the launch date of Discovery. Along with several other Return to Flight actions, the launch team at KSC was required to test fire the three main engines on Discovery while it was at the launch pad. This was known as the Flight Readiness Firing (FRF) and was scheduled to occur on July 26, 1988. The Space Shuttle Program decided to complete the FRF regardless of the known oxidizer vapor leak; therefore, the engineering team assigned to assess the leak had a couple weeks to study possible solutions, while other groups were preparing for the FRF.

First, the exact location of the leak within the pod had to be found (a cutaway view of the Space Shuttle OMS pod can be seen in Figure 24-1). This was difficult because the internals of the aft pods and forward module are not meant to be accessed while the vehicle is at the launch pad. The location of the leak had been isolated to the LRCS N_2O_4 system or the associated tubing through monitoring of the instrumentation in the LCC. The leak was measured to be 0.26 psi per hour (about 800 standard cubic centimeters per hour) and a TVC found the concentration of NO_2 vapor to be 15 ppm at the vehicle vent door. This later decreased to 3 ppm. An access door was removed on the pod's outer skin and several internal thermal blankets were removed. A long section of PVC pipe was then inserted into the pod to function as a guide for a borescope. Using a borescope, the leak was finally isolated (after a six hour search) to a 1/2-inch dynatube fitting on the MD224 leg (the N_2O_4 propellant tank ullage vent). A cross-section view of a dynatube is shown in Figure 24-2 and a photograph of the leak location can be seen in Figure 24-3.

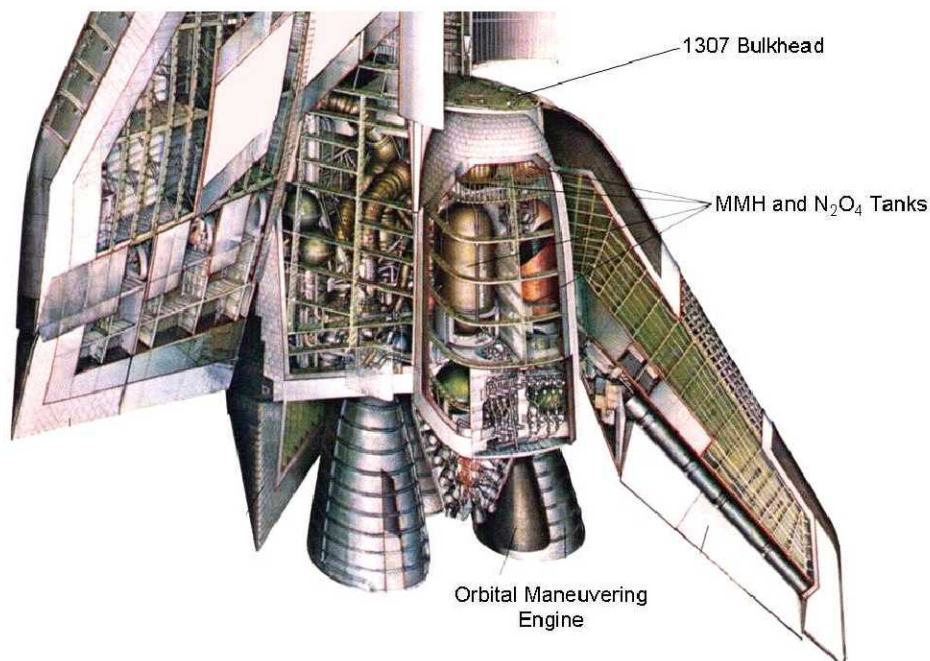

Figure 24-1: Cutaway View of Space Shuttle Orbiter Aft

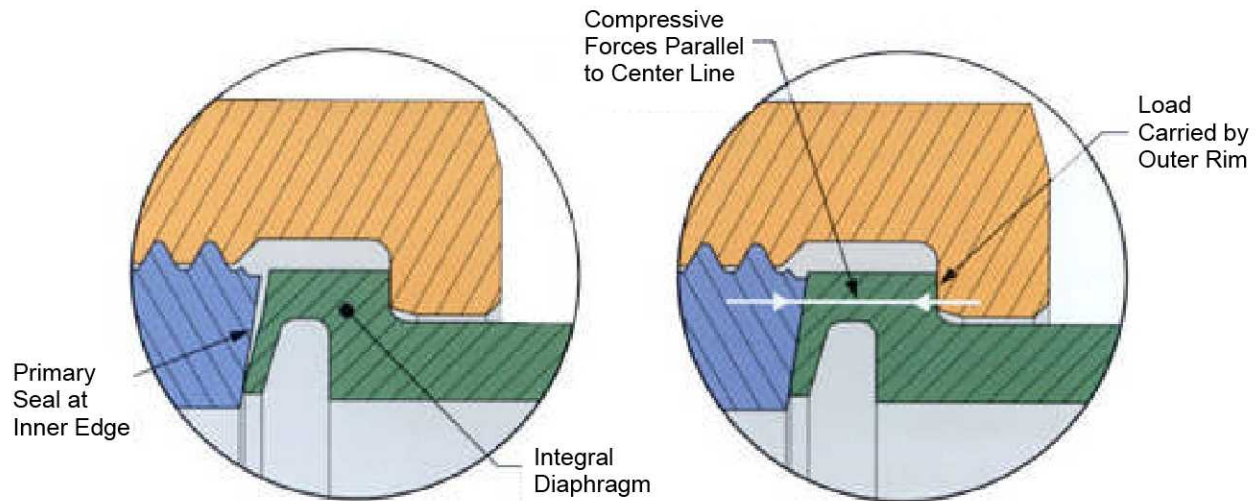

Figure 24-2: Cross-Section of Dynatube Sealing Surface

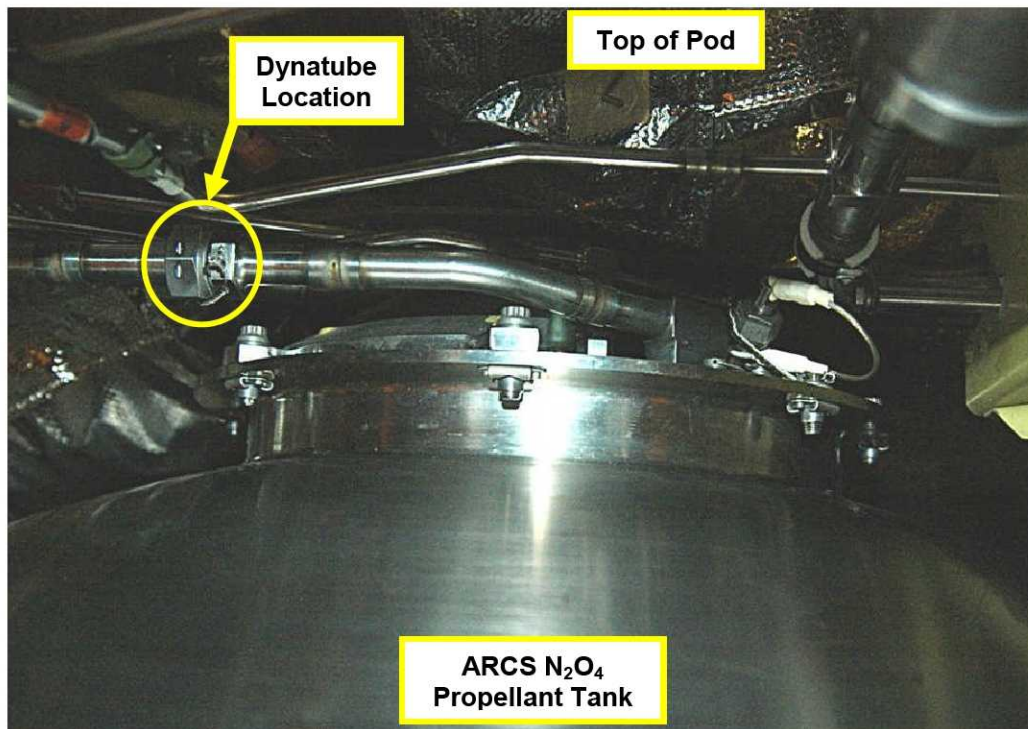

Figure 24-3: Dynatube Location on ARCS N₂O₄ Tank

The engineering team came up with the following solutions to resolve the leaking dynatube:

- Fix the leak at the launch pad (this had never been attempted before due to access issues)
 - Cut a hole in the aft bulkhead structure (1307 bulkhead) and top of OMS/RCS pod
 - Put a “clamshell” around the fitting and inject a sealing compound into it, or
 - Drain the N₂O₄ propellant tank, disconnect and polish the dynatube, or
 - Cut out and replace the dynatube fitting with a new one
 - Send a “stopper” up the line from the QD to plug the line (35 to 40 feet of tubing)

- Return the vehicle to the VAB, de-stack, and swap LP04 with LP01 from Atlantis in the OPF
 - The orbiter aft pods are not able to be removed and replaced at the launch pad since the removal and handling equipment does not exist for this type of operation and the pods are obstructed by the MLP tail service mass (TSM), shown in Figure 24-4
- Return the vehicle to the VAB, de-stack, remove LP04 from Discovery in the OPF, send the pod to the HMF to be repaired, and re-install it onto Discovery once the repairs had been completed
 - This would delay the launch about two months
- Fly with the leak and fix it following landing

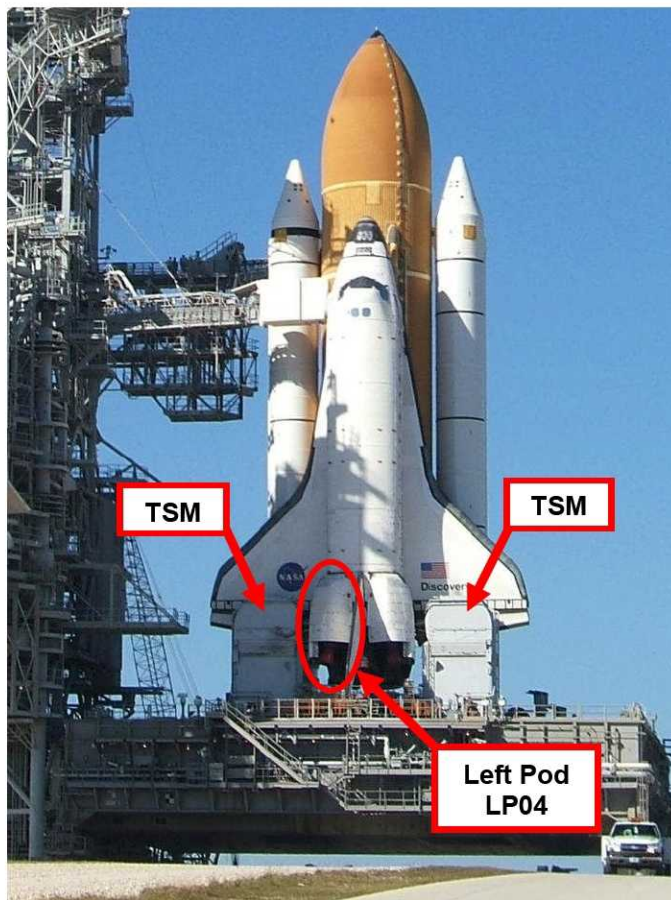

Figure 24-4: Location of Left Pod on Space Shuttle

After a week of deliberation, the “clamshell” was selected as it was the least invasive method to stop the leak prior to launch and it could be completed at the launch pad. Furmanite FSC-6B was used as the sealing compound as a result of it having the best compatibility characteristics with N_2O_4 . The FRF was finally completed on August 10, 1988 following a few hardware-related delays. The repair of the oxidizer vapor leak began on August 17, 1988 with the cutting of two holes in the aft 1307 bulkhead (the bottom of the payload bay with the orbiter in the vertical orientation) and the top of the pod beneath the bulkhead. The dynatube’s safety wire was removed and a “clamshell” (shown in Figure 24-5) was placed over the leak. The Furmanite sealing compound was then injected. The leak was eliminated; therefore, the Space Shuttle Program cleared Discovery for launch, which successfully occurred on September 29, 1988, a few weeks later than the original launch date of September 6, 1988. The delay was a result of multiple items including the FRF test delays, return to flight SRB testing delays in Utah, and the N_2O_4 leak on LP04.

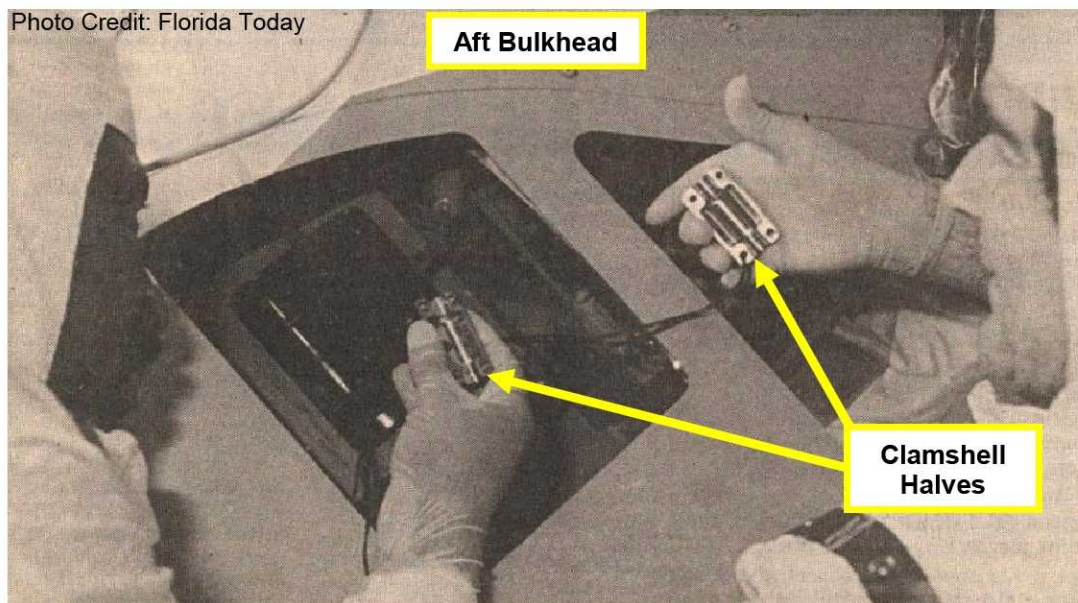

Figure 24-5: Technicians Repairing STS-26R Leak at the 1307 Bulkhead

The proximate cause of the leak was found to be a scratched dynatube. This was discovered during ground processing two missions later when the pod was removed in the OPF and sent to the HMF for repair. It was determined that the scratch must have occurred either when the dynatube was disconnected in October of 1987 to allow access to a nearby valve for a removal and replacement or when it was reconnected in late December of 1987. Following the reconnection, the dynatube fitting passed all leak checks. Transport vibrations may have “altered” the state of the connection between the HMF, OPF, and launch pad; however, this is highly unlikely since dynatubes do not typically change mechanical state, especially with safety wire installed. The Kersey report states that “The most probable cause was that the mass spectrometer probe operator probed the wrong RCS propellant system (i.e. MMH instead of N_2O_4).” Operational human error was the root cause of this incident along with improper training. This categorization was given as a result of the incident being a consequence of either an inadequate inspection of the dynatube sealing surface or an error made during the leak check of the dynatube.

A question was raised concerning the accuracy of the mass specification leak check, which was the leak detection method used on this dynatube in December of 1987. As a result, a new policy was implemented to independently verify zero leakage using two separate methods. Currently, the Space Shuttle hypergol systems utilize a hazardous vapor (“sniff”) leak check, in addition to the mass specification leak check of individual fittings when they are disconnected for any reason.

The Kersey report also lists the following as findings and recommendations to reduce the risk of an undetected dynatube leaks in the future (below some items are resolutions to the findings or recommendations):

- Findings and Recommendations:
 - The system decay check may not have detected this leak.
 - Increased discipline is required at the HMF in the use of OMI’s, Job Cards, and the PRACA [Problem Reporting and Corrective Action] system.
 - A new OMI was developed along with a Quality Awareness Bulletin to ensure problems are properly documented.
 - Training was less than adequate.
 - A new Dynatube Connection and Inspection course was created and added to the technician’s certification plan along with updating the existing courses.

- The existing mass spectrometer units are complex to operate, outdated, and vulnerable to transportation damage.
 - Six new Leybold mass spectrometer units were procured.
- Perform mass spectrometer leak tests of all joints in lieu of rough pressure decay checks, when systems have been decontaminated/cleared of hypergolic propellants.
- Revise procedures to include data sheets, requirements, calculations, and equipment verifications to assure accurate and consistent data is recorded for mass spectrometer leak checks.
 - Procedures were revised.
- Procure new tools, develop repair standard and inspection procedures to the latest criteria, and develop a standard training certification program for all personnel working with dynatube fittings.
 - Two new repair kits were procured.
 - Standard OMI's were developed for dynatube inspection and repair.
 - The inspection specification was updated with specific criteria.
 - A formal certification was established for working with dynatube fittings.
- Form a well-trained and dedicated mass spectrometer maintenance team authorized to do repair work.
 - An engineering "focal point" was established for controlling all efforts with dynatube fittings.

References: Delventhal; Banke; Glisch; Fisher; Kolcum; Draus; Kersey

25 WSTF Fuel Waste Flash Fire (2/16/1990, WSTF)

Following a fuel (it is unclear if it was N_2H_4 or MMH) operation at WSTF, a portable fuel aspirator was being drained into a 6,000 gallon fuel treatment tank. The aspirator tank contained approximately 40 gallons of liquid (5% fuel and 95% water). At the time the treatment tank contained approximately 600 gallons of water, 25 lbs of calcium hypochlorite, and 10 lbs of caustic. The aspirator was gravity drained into the treatment tank and then flushed with approximately 200 gallons of water. Approximately 25 lbs of HTH chlorine was then added to the top of the treatment tank causing an immediate reaction and a flame approximately 15 feet into the air above the tanker hatch (proximate cause). The fire went out after a second or two. There were no reported injuries or hardware damage as a result of the fire. Safety personnel recommended that the water content of the treatment tank be doubled and a sample of the fuel content be taken. It was found that the fuel content was 1.3% after the water had been added (recall that a 65% water to 35% fuel mixture is sufficient to prevent a fire). The fire was likely a result of fuel vapors present in the tank ullage volume. Operational human error is the root cause of this incident as a result of the technician creating a fuel vapor rich environment during the emptying of the aspirator tank; although, preventing this would have been difficult.

One possible cause of the fire is the $NaOH(aq) + HCl \rightarrow NaCl + H_2O$ reaction, which is highly exothermic. It is possible that residual MMH or N_2H_4 dissociated from solution while flowing into the containment tank and collected in the ullage to later ignite from the heat generated by the addition of the HTH into solution. This, however, has not been proven.

Reference: Henderson

26 Aspiration of N_2O_4 into Fuel Vent System (3/26/1990, WSTF TS 401)

On March 26, 1990 at Test Stand (TS) 401, a fuel (MMH) aspiration flexhose was mistakenly connected to the N_2O_4 manifold service valve, SV12, instead of the fuel manifold service valve, SV11. There were incorrect identifications etched on the metal plate above each valve (proximate cause). The valves themselves had the correct color-coded plastic tags attached; however, following the test firing of a nearby engine, the tags had melted and fallen off as a result of the excessive heat.

When the service valve SV12 (incorrectly labeled as SV11) was opened, hypergolic reactions began to take place in the fuel aspirator flexhose and downstream vent lines. The oxidizer manifold pressures dropped from 80 psia to 22 psia and the technicians noted that the flexhose was warm to the touch. The service valve SV12 (really SV11) was immediately closed. Later, the flexhose was removed and flushed with water along with the fuel aspirator. It was approximated that a maximum of 2 tbsp of N₂O₄ may have been aspirated. The technicians noted some discoloration in the flow direction identification tape on the fuel aspiration lines. It is thought that most of the reaction took place in the flexhose and first 25 feet of the TS 401 facility line.

Improper configuration management (improper labeling of components) was the root cause of this incident. Some possible improvements to the test setup include keying in the N₂O₄ and MMH fittings to preclude mismatching and improved labeling and redundant labeling of components.

Reference: Meyer

27 HMF Screens Test Drum MMH Spill (12/7/1990, KSC HMF M7-961 East Test Cell)

During the first aft reaction control system (ARCS) propellant tank screens test at KSC's HMF M7-961 East Test Cell on December 7, 1990, roughly one to two gallons of liquid MMH spilled from the relief valve of a 55 gallon MMH drum and onto the floor of the test cell. The amount of liquid MMH, sufficient to cover the lid of the 55-gallon drum, represented a significant surface area once it spilled to the HMF cell floor. Experience and research have shown that the likelihood of an MMH flash fire is directly proportional to its surface area. It was fortunate that this incident did not result in a fire, which likely did not occur as a result of the conditioned air in the test cell being about 70 °F and the floor area being clear of any iron oxide. Once the source of the leak was determined, the manual fill valve was closed, the drum was pressurized, and the liquid was drained back into a nearby tanker trailer.

It was determined that a hard-line hose from a technician's SCAPE suit caught on a manual fill valve handle and opened it, filling the drum from the tanker (proximate cause). The handle was sticking out beyond the edge of the panel. Following the spill, the handle was removed and rotated 180 degrees so that it no longer protruded beyond the edge of the panel. Entry into the cell was not allowed for several days since some of the liquid MMH ran into areas that were not easily accessible. The root causes of this incident were improper GSE design (protruding handle) and human error (lack of technician situational awareness). One must consider, however, that a technician's visibility in a SCAPE suit is poor, especially peripheral vision.

References: KSC SSP PRACA Database (PR C72-1631-03-001-0015 and PR HMFE-0299)

28 STS-42 OV-103 Ferry Plug Removal MMH Spill (2/12/1992, KSC OPF3)

Following the STS-42 mission and ferry flight of Discovery from EAFB on February 12, 1992, approximately ¼ to ¾ cup of MMH spilled from a RCS thruster nozzle. This occurred when the ferry plug was removed in OPF3 (proximate cause). The liquid contacted the gloves and right shoe of the technician who was removing the plug. There was no reported hardware damage. The collection of liquid in the thruster was believed to be a result of cold temperatures causing the thruster valve to leak (see section 14). The vehicle was not powered during at least one stopover for refueling of the SCA; therefore, the thruster heaters remained off. At this point in the Space Shuttle Program, the limitations and sensitivities of the thruster valves were well understood. The root cause of this incident was improper design as a result of not implementing provisions to provide ground power during the SCA stopover.

Reference: RCS Thruster Heater Power during Ferry Flight Stopovers; Heinrich

29 WSTF Incorrect Flight Cap N₂O₄ Exposure (11/4/1992, WSTF)

While installing flight caps on the OMS ground test article at WSTF on November 4, 1992, a technician attempted to install a ¼-inch AHC cap to a ½-inch AHC. The technician was subsequently exposed to liquid N₂O₄ and suffered minor chemical burns on his hands and forearm. Both the ¼-inch cap and ½-inch cap have a protrusion that acts as a secondary seal when installed on the AHC. The ¼-inch AHC cap protrusion is 0.235-inch longer than the ½-inch AHC cap protrusion (see Figure 29-1). This additional length is enough to actuate (depress) a ½-inch AHC poppet if the proper force is applied to the ¼-inch cap (proximate cause). The only action to reduce the possibility of a similar event occurring in the future (short of a redesign) was more extensive training and certification of the technicians; therefore, this was considered a root cause for this incident along with operational human error and improper vehicle design. Other lessons learned and findings include:

- The appearance of a ¼-inch AHC cap is such that it could be mistaken for a ½-inch AHC cap to an untrained technician
 - The technician was undergoing on the job training under the direct supervision of an experienced technician, but the distinction between a ¼-inch cap and a ½-inch cap was not explained to him
- Age and wear made part number identification on the AHC cap difficult
- Work instructions should be written to include positive identification of interface equipment
- AHC cap mating should not be considered a benign activity; therefore, PPE should be used to protect the employees from credible releases of propellants
- Future designs should consider keying of AHC caps to preclude incorrect size/commodity installation

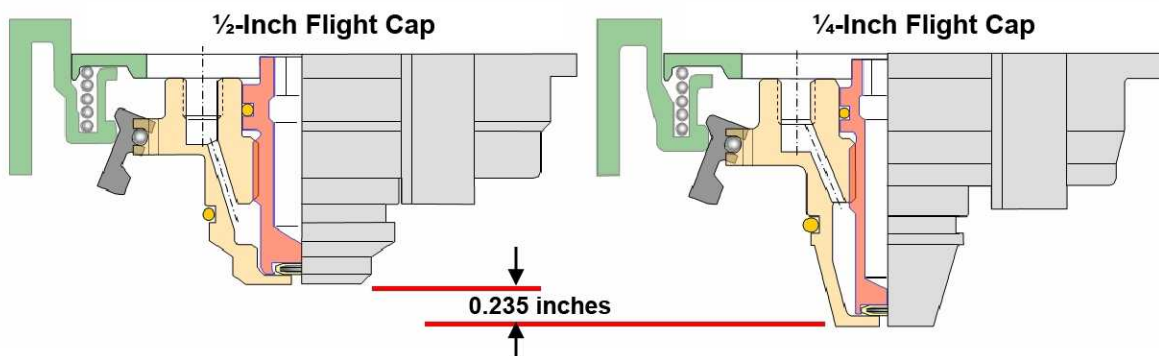

Figure 29-1: ¼-inch and ½-inch Hypergolic Flight Cap Cutaway View

Reference: Reynaud

30 Thermochemical Test Area N₂O₄ Vapor Release (4/21/1994, JSC Building 353)

On April 21, 1994 at the JSC Thermochemical Test Area (TTA) Building 353, there was a large N₂O₄ vapor release at approximately midday. Engineers and technicians were preparing for a simulated altitude test of a small bi-propellant rocket engine. Oxidizer was first flowed in the system on February 22, 1994; however, a few leaks were noted and the system was drained and refilled twice following troubleshooting of the noted leaks. During the thruster firing procedures on April 21, 1994, a three-way solenoid valve failed allowing liquid N₂O₄ to leak into the vent line and oxidizer burner stack (proximate cause). It was later determined that the valve had an extra one-half of a Teflon seal, extensive corrosion, and some small scratches on the armature. It is unclear which particular item caused the valve to leak, but the most likely candidate was the extra one-half of Teflon seal.

The test team was unaware of the valve failure and continued on with their procedures. They first brought up pressure in the oxidizer tank to approximately 850 psig, which was greater than the desired

pressure of 800 psig. The solenoid valve leak rate then increased filling the burner stack with N_2O_4 liquid and vapors. The over-pressurization required the test team to vent approximately 50 psig off of the system. When they proceeded with the venting process, a small amount of oxidizer vapor exited the burner stack. This was an indication that there was a problem with the system; however, the test team proceeded on while rationalizing the small oxidizer cloud as an incorrect methane burner supply valve setting.

The test team decided to continue on with their procedures even though there was an inadvertent oxidizer vapor release and some data in the control room was indicating possible issues with the system. It is unknown if the test team simply did not notice the data or they misinterpreted it. A short amount of time passed while the test team assessed the situation allowing the oxidizer tank pressure to drop (as a result of the leaking three-way solenoid valve) to 600 psig. The test team failed to notice the significance of the 200 psi pressure drop and proceeded to increase the oxidizer tank pressure again to approximately 800 psig. When they did this, there was a large N_2O_4 (NO_2) vapor release from the burner stack (approximately 16 to 20 gallons of liquid N_2O_4 and NO_2 vapors). The oxidizer cloud traveled downwind in a westerly direction resulting in the displacement of dozens of people. About 81 people (9 NASA personnel, 70 contractors, and 2 visitors) received minor injuries from inhalation of the oxidizer vapors.

The following are contributing factors and/or lessons learned from this incident:

- A formal emergency response did not exist for this type of event
 - The emergency response personnel at JSC lacked the proper training and practice for a hypergol spill, vapor release, or fire at the time
- The process lacked proper identification of safety control hazards and emergency procedures
- There were insufficient controls in the system as it contained single point failures (improper design; a root cause)
- The system should have contained a bypass relief valve that could withstand liquid lock (improper design; a root cause)
- Several attempts were made to tighten leaky fittings and clean up liquid oxidizer spills without the use of any PPE
- The test team failed to notice the severity of the events as they were unfolding by either the data that was being obtained in the control room or the initial small cloud of NO_2 vapor that was released; lack of situational awareness or human error was one root cause of this incident
- The test team lacked the proper training for dealing with hypergols (another root cause)
- JSC management was unaware of the risks in preparing for and conducting the test of this bi-propellant rocket engine
- There was a lack of voice and video recording of this operation
- Facility changes were not processed correctly and were not distributed to the appropriate disciplines; improper configuration management was another root cause of this incident
- KSC management also felt the need to assess their own safety practices following this incident
 - GSE and facility designs, training requirements, emergency response procedures, and procedure review practices were reviewed and updated accordingly for all hypergolic systems at KSC

References: Rathgeber; Torpey

31 Titan IV A K-9 N_2O_4 Spill (8/20/1994, CCAFS SLC-41)

On August 20, 1994, at Space Launch Complex 41 (SLC-41) on CCAFS there was a large release of liquid N_2O_4 . Oxidizer was being loaded into the Titan IV A's solid rocket motor (SRM) thrust vector control (TVC) system in preparation for the launch of the National Reconnaissance Office's Mercury Electronic Intelligence or ELINT satellite on August 27, 1994. The N_2O_4 was used to alter the combustion in the Titan IV A SRM nozzle and, therefore, provide TVC. A photograph of the SLC-41 launch pad with a Titan IV A is shown in Figure 31-1. A diagram of the Titan IV A's TVC system is shown in Figure 31-2 with the numbered callouts listed in Table 31-1. The incident occurred about three and a half hours after sunrise

when the solar heat caused the pressure to increase in the N_2O_4 tubing while the system was in a static configuration.

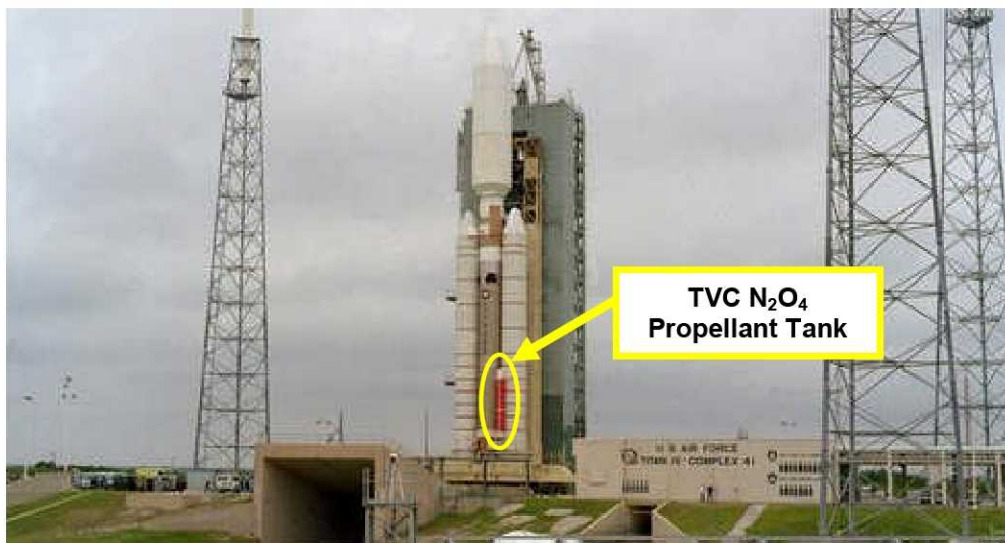

Figure 31-1: SLC-41 with Titan IV A (Servicing Structure Retracted)

The pressure increase went unnoticed by the engineers and technicians. Remote data monitoring was available on the launch vehicle, but not on the propellant transfer systems (GSE). Local dial gauges likely showed the increase in pressure; however, there were no technicians monitoring these particular gauges. The pressure rise eventually caused a weld seam to fail at the base of the transfer system (proximate cause). This portion of the N_2O_4 servicing GSE lacked a relief valve, thus allowing the propellant in the tubing to become “liquid locked” since a drain-back and purge had not been completed (improper design; a root cause). There was no damage to the GSE (excluding the ruptured tubing) or vehicle hardware and there were no reported injuries.

Usually this tubing would not contain any propellant unless a loading operation was underway; although, schedule pressure led to the decision to halt the propellant drain-back and purge following the loading. The processing schedule had been delayed by a couple hours as a result of addressing a leak on a fill and drain valve on the SRM TVC system. Once the fill and drain valve leak was repaired, other non-related, time-critical work required attention on the upper stage of the Titan IV rocket. As a result, the Launch Conductor delayed the purge of the oxidizer loading system by several hours since these two operations could not be conducted in parallel. Once the upper stage task was completed, the Launch Conductor delayed the purge again to allow the engineers and technicians to prepare for the fuel loading operation. Fifteen minutes after the vehicle fuel tanks were loaded for flight, the N_2O_4 GSE tubing ruptured. The release amount was approximately 350 to 400 gallons into the launch pad transfer slip.

Another root cause of this incident was determined to be frivolous procedure deviations. The loading team and Launch Conductor had experience with successfully delaying the oxidizer drain-back and purge; however, this experience was based on insulated oxidizer tubing. The tubing at SLC-41 had recently been removed and replaced with non-insulated tubing as a result of the moisture trapped in the insulation causing accelerated corrosion. The loading team and the Launch Conductor either did not recall this or they were never told.

There are requirements for launch Pads 39A and 39B to have seamless pipe throughout and to have relief valves in tubing that could become “liquid locked.” Following the incident at SLC-41, the procedures were changed to preclude this sort of incident from happening in the future. The procedure deviation approval rules were also reaffirmed to the loading team and Launch Conductor.

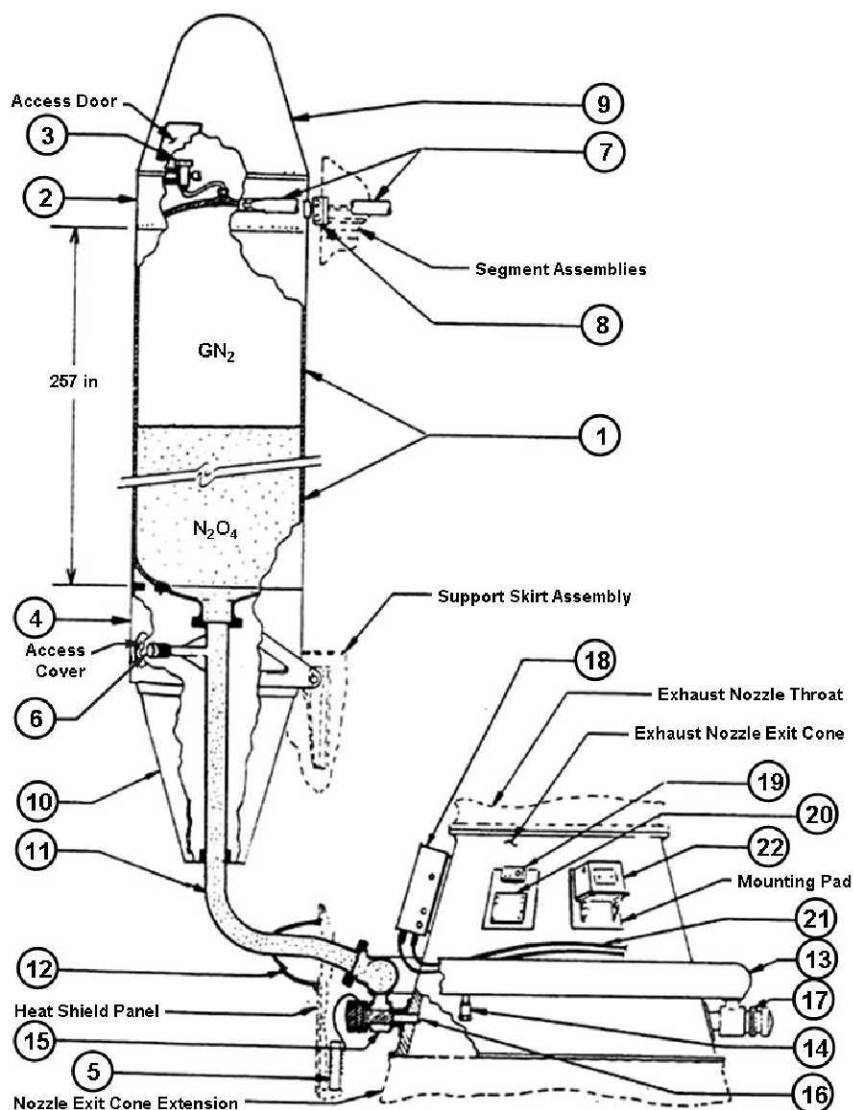

Figure 31-2: Titan IV A TVC System Schematic (see Table 31-1 for references)

Table 31-1: Component Callout Descriptions

<u>Item #</u>	<u>Component Item</u>	<u>Item #</u>	<u>Component Item</u>
1	Injectant Tank	12	TVC Heat Barrier Boot
2	TVC Tank Extension Assembly	13	Injectant Manifold
3	GN ₂ Fill and Vent Valve	14	Self-Sealing Coupling Assembly
4	Tank Assembly Base Section	15	Injectant Valve Housing
5	GN ₂ Valve Purge System	16	Pyro seal Assembly Components
6	Quick Disconnect Coupling Assembly	17	Injectant Valve (FCV)
7	Tank Assembly Support Tie Rod	18	TVC Distribution Box
8	TVC Tank Extension Shear Fitting	19	Power Transfer Switch
9	TVC Tank Assembly Fairing	20	Power Bus Terminal Strip Assembly
10	Transfer Tube Support Assembly	21	Electrical Distribution System
11	Injectant Transfer Tube	22	TVC System Storage Battery

Reference: Rodgers; Skaja

32 STS-69 OV-105 Left Pod MMH Fire (12/9/1994, KSC OPF1)

During the STS-69 OV-105 flow, while performing a thruster L3D removal and replacement, an MMH flame was reported in the Space Shuttle left OMS pod stinger area (see Figure 32-1 for the relative location of the stingers). The technician in SCAPE was preparing to inspect the dynatube (approximately an hour after the thruster was removed) with a mirror when he reported a small flame on the MMH thruster feedline dynatube. Another technician was unable to find any water to put out the fire and mistakenly picked up an alcohol bottle and sprayed the flame which produced a small flash near the feedline, igniting the residual MMH inside it. It is believed that the technician thought the spray bottle was Freon. It was reported that the flame was extinguished by the technician placing his SCAPE glove over the dynatube end. This was probably not the best idea since MMH can react exothermically in a rigid volume and burn in an atmosphere 2.5% to 98% by volume in air.

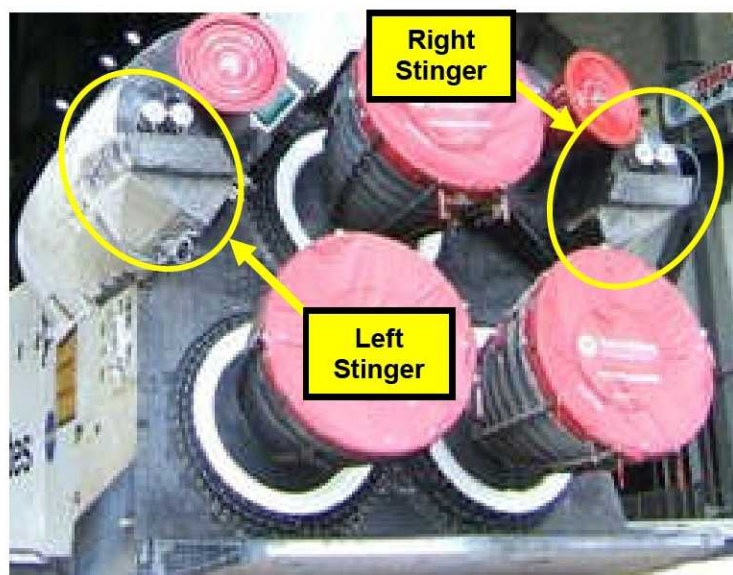

Figure 32-1: Stinger Locations on Orbiter

Prior to the reported fire, the technician removed the Aclar (plastic film) bag from the open end of the thruster feedline dynatube fitting. This fitting connects the manifold to the thruster. When he did this, he noted that there was an exceptionally large amount of fuel vapor present and some liquid MMH was dripping from the open line. The technician proceeded to place the aspirator directly on the feedline dynatube (the procedure and known practice was to place the aspirator perpendicular to the dynatube exit). This was likely the proximate cause of the fire. The engineer on console then noted that the manifold pressure dropped from 16 psia indicated to 6 psia indicated in about five seconds (the transducer had a 2 psi offset). The manifold pressure stabilized to 16 psia indicated after a couple minutes. At this point, the technician was instructed by the engineer to remove the aspirator from the dynatube. He did this and then left the area to find a mirror to aid in the dynatube inspection. When he approached the dynatube with the mirror he noted a “cream/yellowish color” flame and “heat waves.” As previously mentioned, he proceeded to put out the flame with his glove after the other technician doused the area with alcohol.

The engineer on console was not convinced that the technician had seen a flame because it was his belief that MMH fires are not visible or are clear (as noted in section 1.3 Properties of Monomethylhydrazine (MMH), MMH flames are usually light yellow in color). He thought that the technician had seen some off-gassing of the MMH that was enhanced by a nearby light source; however, this cannot explain the flash fire from the alcohol spray. This flash required a flame to already be present.

The engineer voiced his thoughts to management and they trusted his opinions as the system expert. The technician who reportedly put out the fire with his glove, later made a statement that he was instructed to “not talk about flames or fires over the net” by engineering and technician operations. If this did actually occur, it is very unfortunate that the technician was specifically told to not follow the appropriate safety protocol in the event of an incident.

It was later determined through analysis that an MMH decomposition (exothermic) reaction had occurred in the thruster feedline and there was likely a flame present. When the aspirator was placed onto the dynatube, it removed the inert GN₂ from the line and replaced it with an inrush of air. The residual MMH that remained as a thin film around the inner diameter of the tube began to react with the oxygen in the air. When the decomposition reaction reached a temperature of 382 °F within the interior of the feedline, ignition occurred. A flame will persist until the fuel is exhausted or the oxidizer is removed or exhausted. In this case, the glove of the technician’s SCAPE suit removed the oxidizer.

No damage to the tubing or to other hardware was found during the inspections immediately following the fire. The PR closure stated the following as a possible reason for ignition:

“...the ignition was the result of a vacuum being inadvertently placed on the line by a technician using a spill aspirator. This vacuum removed the inert GN₂ which was present inside the line. When the aspirator was pulled away, it allowed air to enter the line. The air, which contains oxygen and carbon dioxide, reacted with the thin layer of fuel [MMH] residue inside the tube. This reaction continued until the fuel [MMH] has reached the flammability limit of 382 °F.”

Possible annealing of the feedline became a concern. This was addressed in the original PR in which the closure stated the following:

“...assuming the worst case where the tubing was annealed during the fire, the maximum pressure (approximately 1200 psia) the line could have possibly seen was well below (less than 50%) the yielded strength of 5/8-inch diameter, 0.028-inch thick 21-6-9 cres [corrosion resistant steel] tubing in an annealed condition.”

This event displayed a break-down on many levels including:

- The technicians were improperly trained (aspirator directly on dynatube)
 - Improper training was one root cause of this incident
- Operational procedures did not adequately safe the system for hazardous operations (a root cause)
- The engineer was not cognizant that an MMH fire has a light yellow flame and is very likely to ignite under the right conditions (decomposition reaction)
- The technician was told not to discuss an emergency-type situation on the communications net
- A charged water hose or water source was not nearby during the operation

References: Applewhite; Weber

33 STS-69 OV-105 Right Pod MMH Fire (5/4/1995, KSC OPF1)

During the STS-69 OV-105 flow, while performing a thruster R1A removal and replacement, a fire broke out in the Space Shuttle right OMS pod stinger area. The fire burned strongly for about 30 seconds and a smaller flame burned for about one minute and 45 seconds. The size of the flame was estimated to be approximately 15 inches x 11 inches x 11 inches with a damage region of approximately 22 inches x 14 inches x 14 inches in the stinger. The materials that burned included several ounces of fuel, a shop light, and the Orcofilm spill protection (flame retardant covering films). Figure 32-1 is a still image from the video recording during the fire and Figure 33-2 is a clearer color photograph of the same area for reference.

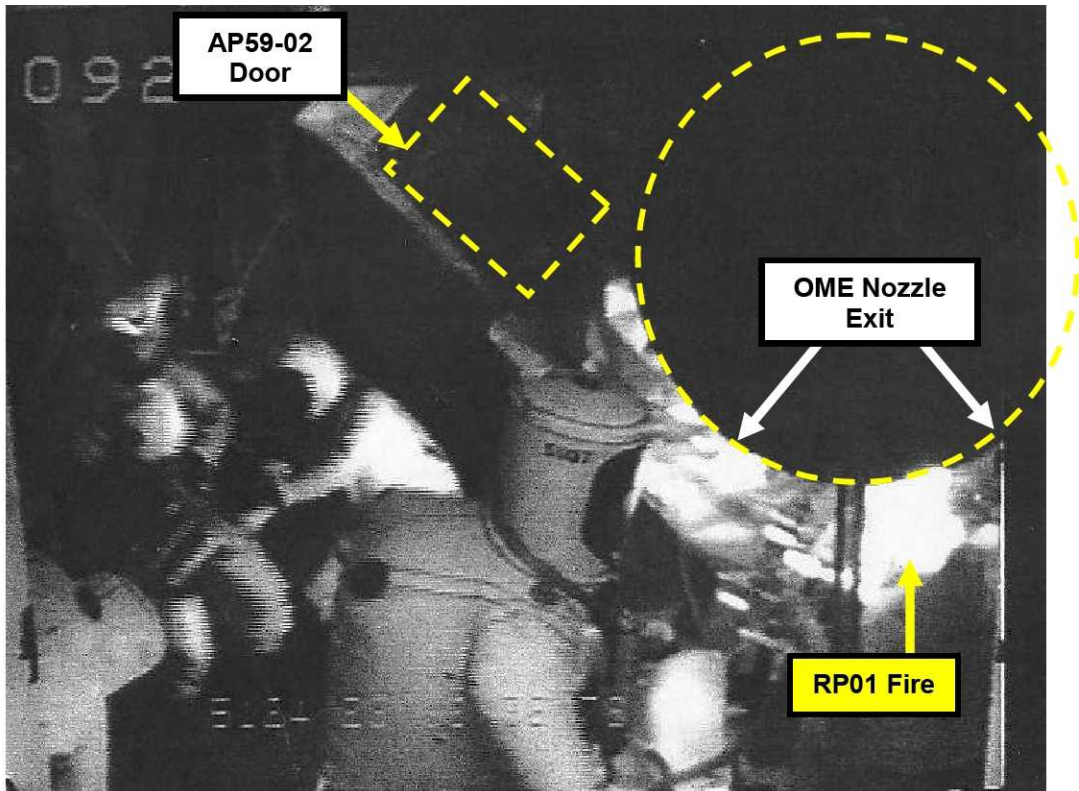

Figure 33-1: Still Photograph from Video of RP01 Fire

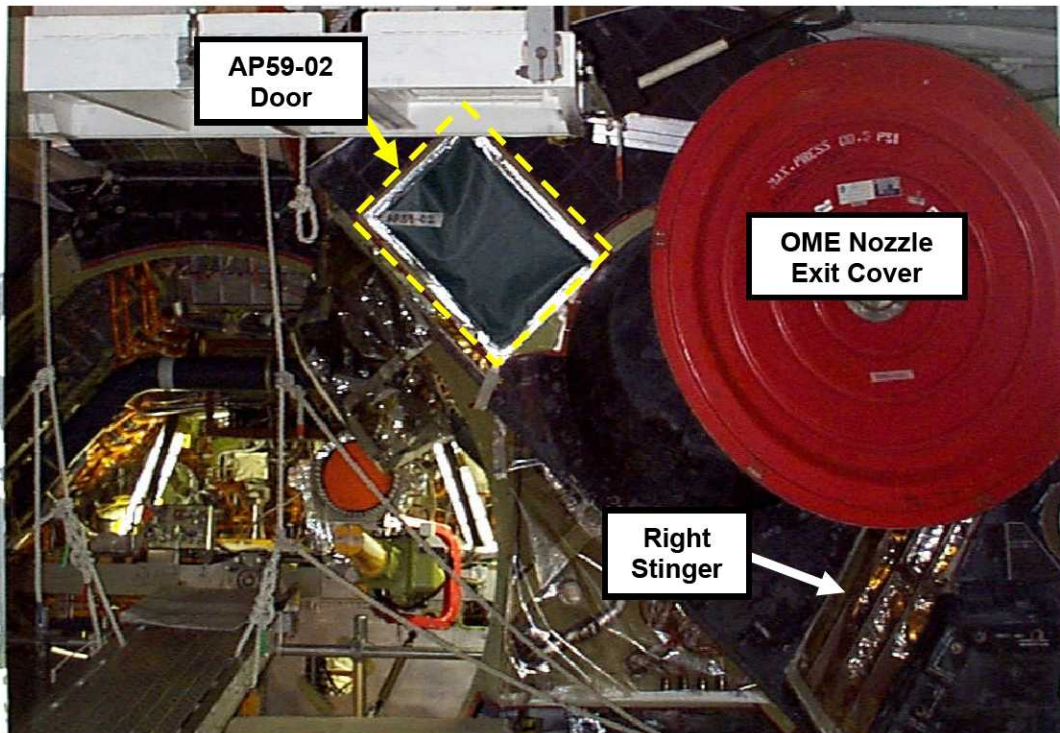

Figure 33-2: Color Photograph of Right Pod and Orbiter Aft

A technician in SCAPE was disconnecting the R1A thruster MMH feedline dynatube during a thruster removal and replacement procedure. The procedure was initiated following an in-flight anomaly that occurred on the thruster during on-orbit operations (R1A primary thruster failed off due to a low chamber pressure). The N_2O_4 dynatube had already been disconnected and double-bagged in attempt to contain the residual vapors that were being released from the fitting. The technicians were told to place an aspirator near the N_2O_4 dynatube and proceed with the fuel feedline disconnect operation. When the seal of the fuel dynatube was broken by the technician using a wrench, he noted that there were “large drops of fuel being siphoned away by the aspirator.” Immediately following this, a fire erupted. There were six SCAPE personnel in the area when the fire was first reported. The proximate cause of this incident was the disconnection of the dynatube without knowing that there was liquid fuel within the tubing.

The technicians managed to put the fire out with a parts rinse bucket nearby, which they had to refill several times with water in the safety shower. Apparently, there was not a charged water line in the vicinity. Once the fire had been reduced in size from a large flame to a small flame at the open end of the dynatube, a technician cupped the end of the dynatube with his SCAPE suit glove and placed the aspirator in the flame, which immediately put out the fire.

The engineers on console in the LCC believed that they had purged the manifolds enough to reduce the residual MMH to manageable levels. Immediately preceding the feedline dynatube disconnect, the engineer on console incorrectly read the fuel feedline pressure transducer on the vehicle. The subject transducer indicated 16 psia (approximately atmospheric pressure). In actuality, the transducer was biased low (as determined from a previous test completed during the OMDP of RP01 about 18 months prior); therefore, the actual pressure in the manifold had increased to about eight psi above atmospheric pressure. There had also been a shift change between the venting and disconnection operations which may have led to the transducer bias going unnoticed. The increase in pressure may have been a result of a leaking manifold isolation valve (LV317, the valve holding back the bulk propellant from the feedline).

Another possible scenario (not included in the formal mishap report) for the pressure increase was put forth stating the pulse purges were unable to remove all the liquid MMH as a result of a low point trap present in the manifold near the MD317 (manifold 1 drain/purge QD) AHC interface. Figure 33-3 shows the basic layout and low point in fuel manifold 1 in the right pod stinger area. It is believed that during the purge, gas was unable to enter the line through the MD317 QD to displace the liquid MMH out of the manifold. This was a result of a small bubble that had formed in the low point as a result of helium coming out of the liquid MMH/helium solution. The helium slowly coming out of solution may have been the source of the pressure rise in the manifold rather than a leaking manifold isolation valve. Once the fire started, it heated the area thus increasing the pressure and pushing additional fuel out of the fuel feedline that was trapped. In both scenarios (leaking manifold isolation valve or helium coming out of solution), liquid MMH was present in the manifold line just prior to and during the fire and the manifold pressure increase went unnoticed.

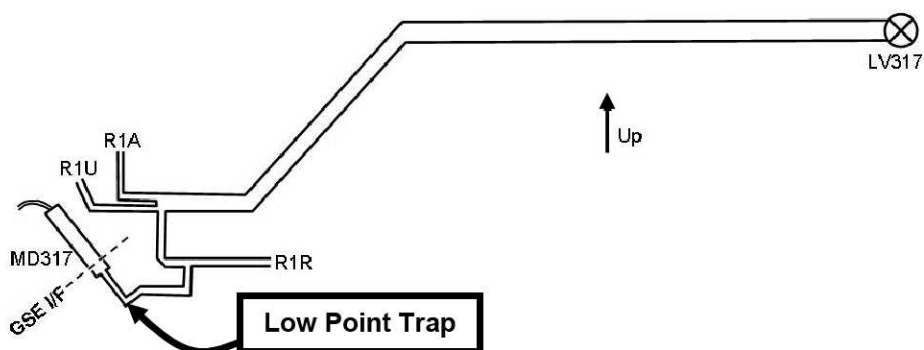

Figure 33-3: Approximate Manifold 1 Layout Schematic

The “official” cause of the ignition from the mishap report was stated to be electrostatic discharge passed from the materials (Orcofilm being one of them) used for spill protection to the SCAPE suits, gloves, and tools. The spill protection materials and SCAPE suit failed electrostatic testing performed following the mishap. Another possible cause for ignition (not put forth by the mishap report) was a decomposition combustion reaction of the MMH and a material that it contacted. A hypergolic reaction with the N_2O_4 (NO_2) vapors that were possibly leaking from a nearby double-bagged oxidizer feedline dynatube was not a likely source of ignition since the aspirator was positioned directly adjacent to the open end of the oxidizer feedline. An atmosphere of approximately 10% N_2O_4 (NO_2) vapors is needed for a hypergolic reaction with MMH vapors in air. With the amount of atmosphere that the aspirator was drawing in and the fact that the feedline was not receiving a constant pressurized source of N_2O_4 , obtaining a 10% atmosphere of N_2O_4 (NO_2) vapors was not possible.

About six months to a year prior to the fires on left and right pods of OV-105, a Tiger Team (an independent investigation team) was investigating on-orbit thruster failures. One finding from the study was that evacuation of the thruster feedlines to remove residual propellant prior to a thruster removal and replacement was detrimental to the health of the thruster valves. Therefore, the thruster removal and replacement procedures were changed to disconnect the thruster feedlines utilizing a pulse purge rather than an evacuation, also known as a “hot” removal and replacement. Dozens of thrusters were successfully removed and replaced without incident following this change. The inadequacy of the pulse purges in removing all of the residual fuel in the feedline and the unnoticed pressure increase in the manifold from either a leaking manifold isolation valve or helium coming out of solution (operational human errors) were the root causes of this incident, but other unknown factors likely played a role.

Following the fire, the oxidizer feedline was plugged and the fuel feedline fitting was tightened to safe the system. There were no reported injuries. There was an appreciable amount of damage to flight hardware from the fire and the water that was used to extinguish it, including several RCS thrusters, three purge ducts, some electrical harness ties, and eight thermal control system (TCS) blankets. This damage required removal of the OMS pod for refurbishment at the HMF. A total of 33 PRACA items were taken for damage as a result of the fire. The three purge ducts, eight thermal blankets, and four propellant line clamps were removed and replaced with like items along with thrusters R1R, R1U, R3A, R3R, R3D, and R1A (which was removed in the OPF immediately following the fire). The only thrusters that had fire damage were R1R, R1U, and R3A, the rest were required to be removed since they were located on the same manifold as another thruster that was being removed. The thrusters were refurbished and returned to logistics as usable spares.

The delay as a result of the repair from the fire was an impact to the processing flow of the pod; therefore, two pods were swapped between orbiters. OV-102's RP05 was re-assigned to OV-105 and RP01 went to OV-102, after repairs. RP05 had just come out of its OMDP.

There was not one simple reason for this incident. As with most accidents, many different, seemingly unrelated items created the exact environment needed to support a fuel fire. The following items were noted as lessons learned from this incident:

- Operational procedures did not adequately safe the system for hazardous operations (a root cause)
- System hardware design forced complicated thruster removal and replacement operations
 - Tiger Team results led to an increase in hazard during the thruster removal and replacement operation
- Designs should be completed with operability in mind
 - The thruster feedline dynatubes in the FRCS allow for independent disconnection of the MMH and N_2O_4 lines, where the ARCS feedline dynatube bellows force the disconnection of the MMH and N_2O_4 lines simultaneously (the orbiter FRCS and aft pods were designed and built by different companies)
- Understand and design to mitigate external/environmental impacts
- Understand failure modes during all phases of operations

- Two valve isolation is the desired configuration (if possible) during an operation involving hypergols being opened to the atmosphere
- Training of the technicians that performed the operation was found to be inadequate (another root cause)
- Fire fighting equipment should be nearby when an operation involving the opening of a hypergolic propellant line to atmosphere is being performed
 - Walkdowns prior to the operation failed to point out the lack of fire fighting equipment
 - It should be noted that SCAPE personnel are not required to stay and fight a fire; however, historically most stay in attempt to contain the situation

References: Buzzard; Draus

34 ORSU Open Manual Valve N₂O₄ Spill (3/1/1996, WSTF 400-Area)

On March 1, 1996 at the 400-Area Oxidizer Ready Storage Unit (ORSU) at WSTF, a large spill (about 90 gallons) of N₂O₄ occurred. This incident was the direct result of manual valve MV-4OX-HB77 being slightly open allowing a 1-2 gpm flow rate of liquid N₂O₄ into the vent system of the 300 gallon oxidizer catch tank (proximate cause). It is believed that a propellant tank venting in TS 405 caused liquid N₂O₄ to accumulate in the vent system. The liquid was subsequently pushed out through the vent and into the oxidizer burner stack. This venting was completed following a PRCS thruster acceptance test procedure (ATP) in the test stand. It is standard procedure to vent the primary thruster propellant tanks from approximately 260 psia to approximately 50 psia following an ATP.

There was a crew located at the ORSU to collect a sample of the N₂O₄ in the tank since it was being circulated on the same day to filter out particulate. Prior to this sample being taken, the primary oxidizer burner was set to 100 percent by the blockhouse monitor to support venting of N₂O₄ (NO₂) vapors from the ullage of the storage tank to ambient pressure. The TS 405 propellant tank venting occurred shortly thereafter. The personnel in the vicinity were not exposed to the liquid N₂O₄ or NO₂ vapors and were immediately evacuated to a safe area. It was later determined that a contributing factor was that the 400-Area vent system was not an active system; therefore, it did not receive the full engineering design review as did the pressurized (active) system (a root cause). It was also found that the 400-Area configuration was not properly managed (a root cause).

Reference: "Investigation of the WSTF 400-Area Oxidizer Spill Incident"

35 OPF2 GSE MMH Spill (2/17/1997, KSC OPF2)

In OPF2 on February 17, 1997, liquid MMH (approximately a pint) splashed onto three personnel while they were working on removing an overhead 1-¼-inch cap from the hypergolic vent line (the proximate cause) causing chemical burns to the arms of all three and the neck of one. They were all sent to the OHF. Five other individuals were sent to the OHF as a result of MMH vapor inhalation.

The technicians were performing a modification to the MMH eductor system on the 10-foot left platform of OPF2. The modification included the installation of permanent hardware by removing flexhose interfaces and installing hard-line tubing, adding a suction port, and raising the eductor panel from the floor and attaching it to a railing. The last time the eductor system was used for an operation on the orbiter was about two years prior, in which MMH was drained from the LRCS manifold two of Discovery for the later removal of thruster L2D. It was later determined that the vent line had only been "blown down" rather than educted with a vacuum; therefore, liquid was able to collect in the low points, which should have been designed out of the system (improper GSE design; a root cause).

With the technicians in supplied air respirators and hypergol compatible aprons and gloves, the first part of the modification, which consisted of installing a new valve and tee assembly for the additional suction port, was completed without incident. No liquid MMH was noted as spilling even though the same 1-¼-inch vent line from which the spill occurs a couple weeks later, was opened. A reading of 0.8 ppm was

noted at one of the capped fittings on the tubing, but this was not out of the ordinary. The 1-¼-inch vent line was then opened a second time to install the modified 1-¼-inch line that connected the new valve to the vent line. Minor vapors were detected when the 1-¼-inch vent line cap was removed. The technicians found that the modified line was too short and some other lines were installed incorrectly, so they re-installed the 1-¼-inch vent line cap and reported the problems.

When they returned to fix the installation a few days later, a few droplets of MMH dripped onto one technician's glove and arm when he initially loosened the cap. He quickly rinsed off his arm in the nearby safety shower. The safety technician then proceeded to take interscan readings of the fitting, which he reported were 0.0 ppm. Since the readings were found to be 0.0 ppm, the technicians determined that the liquid was probably alcohol (used for cleaning the fittings), water, or condensate. They all then decided that it was safe to continue. Following this, the technician began to remove the overhead 1-¼-inch vent line cap when liquid MMH spilled out onto his and the other technician's skin and the surrounding GSE. Another safety technician nearby notified the pad leader at the OPF operations desk to evacuate the OPF and activate the hypergol fans to remove the residual fuel vapors. The area warning "warbler" was activated and proved to be ineffective at getting all of the personnel out of OPF1, OPF2, and the OPF annex; therefore, the fire alarm was activated. This deactivated the hypergol exhaust fans. Why the area warning "warbler" was ineffective is unknown.

The exposed technicians proceeded to take turns rinsing off in the safety shower while fully clothed and in their supplied air respirators. They then began their evacuation of the facility; however, their supplied air hoses became entangled forcing them to remove their masks while still in the MMH vapor cloud. Once they had exited the facility, paramedics on site began to examine them inside an ambulance. One paramedic indicated that the technicians had a fuel odor; therefore, they were instructed to remove their clothes so they could be rinsed off by fire personnel. They were then given blankets and transported to the OHF in two separate ambulances. One technician was told by paramedics to report to the OHF using his own personal vehicle. When he arrived at the OHF his clothes were found to be contaminated with fuel. He was told to shower and then put his contaminated pants back on once they were found to be 0.0 ppm. About 30 minutes later, he removed the contaminated pants again as a result of a fuel odor, and he along with the other technicians were given coveralls. When fuel exposed clothing is rinsed with water, the water can conceal the residual fuel in the clothing until the water evaporates. This is likely why the residual fuel went unnoticed in the technician's pants resulting in him being asked to put his clothes back on after showering at the OHF. Per safety guidelines, the clothing should have been treated as hazardous waste.

The reason for the spill was an unknown low point in the 1-¼-inch vent line which trapped liquid MMH. The reconfiguring of the lines allowed the low point to move around within the line and go unnoticed. It appears that the technicians reacted as best they could with the tools they had with the exception of not removing their clothing in the safety shower. The interscan fuel detector used during the operation was found to have a faulty pump. The pump was contaminated with liquid MMH and only worked intermittently; although, the interscan did read full scale high during the spill along with its alarm sounding. This could be the reason for the 0.0 ppm reading when the technician initially opened the cap; however, the pump could have been contaminated during the spill. There were several lessons learned following this incident including:

- The fire alarms deactivated the hypergol fans and should not be used during a hypergol related evacuation
 - Following the incident a by-pass switch was added to the heating, ventilation, and air conditioning system outside each OPF so the hypergol fans can be turned on when a fire alarm has been activated
 - A fire alarm should not be used to evacuate personnel following a propellant spill
 - All processing facility personnel should be familiar with evacuation alarms
- The recommended decontamination procedure was not followed in which the person's clothing is to be removed prior to entering the safety shower and the clothes are to be treated as hazardous waste

- Following this incident “modesty garments” were placed in boxes near the safety showers throughout KSC
- Curtains were also added to the safety showers
- After being involved in a serious incident, personnel should immediately seek medical attention and should not be asked to drive themselves to the medical facility
- The medical personnel did not seem to be knowledgeable as to the proper treatment of a person who has been exposed to hypergols
- An improper GSE design can destine a system for failure
 - Low points in GSE should be designed out (root cause)

Reference: Stefanovic

36 HMF Sample Valve MMH Spill (3/26/1997, KSC HMF M7-1212 West Test Cell)

On March 26, 1997, in the HMF M7-1212 West Test Cell, an MMH spill occurred from a GSE sample valve. FRC4 had been removed from OV-104 as a result of a suspect thruster dynatube seal saver installation. The dynatube disconnection operation required the thruster manifold to be drained and educted for no less than eight hours. Following this, preparations were made to perform a sampling operation. Three technicians set up the 20-foot safety clear area. One technician remained outside the clear and was not wearing any PPE. The other two donned hypergol compatible aprons and gloves and wore supplied air respirators.

One technician powered up the aspirator and then began to remove the sampling valve outlet cap from the MD137 flexhose (see Figure 36-1 for a close-up view of the sampling valve). A TVC of the area was then performed with a resulting reading of 0.0 ppm. The technician laid the aspirator hose on the side of the rack, which was not a suitable position to capture any liquid or vapor that may be released from the valve outlet as the procedure stated.

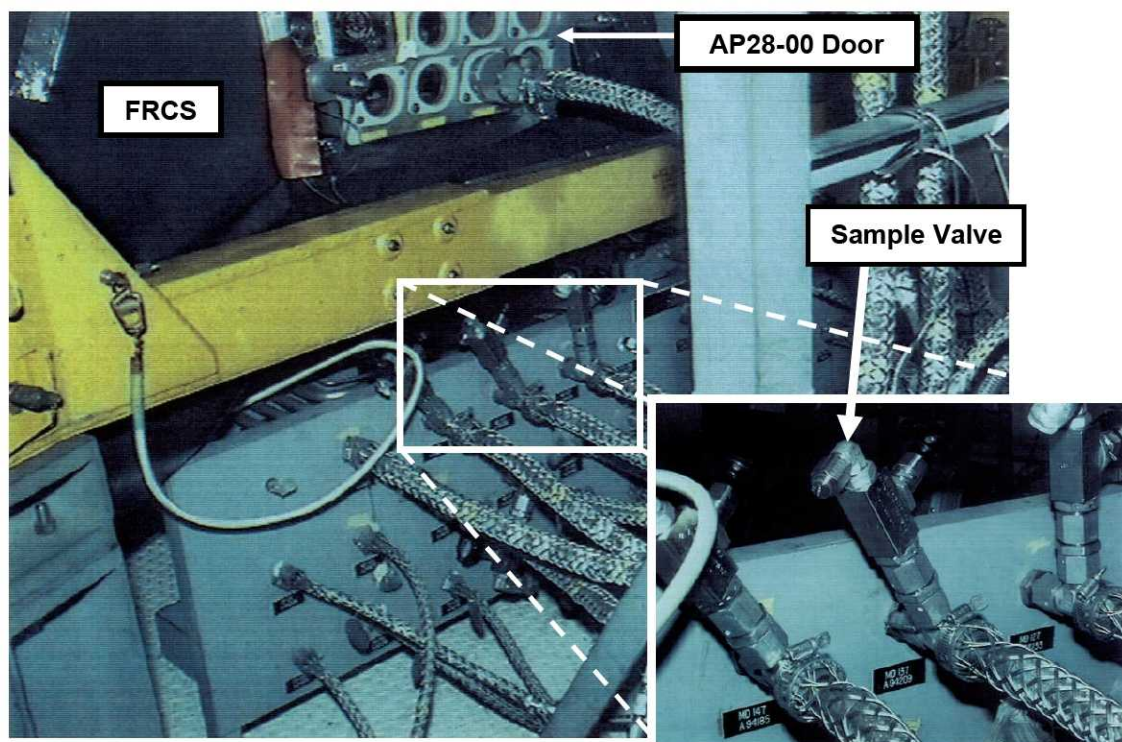

Figure 36-1: MD137 Flexhose Sample Valve

The technicians were then at the point in the procedure where the valve was to be opened. The procedure was written to imply that there may be some vapor released from the valve when it was opened. Liquid MMH was not expected, but, as it turns out, there was a liquid release once the valve was opened. MMH splashed out of the sample valve and onto one technician's left arm, the glove of the other technician, and the surrounding area. It is estimated that approximately $\frac{3}{4}$ -cup of liquid MMH spilled from the valve. The technician immediately closed the valve and began to evacuate the test cell along with the other technicians. He exited the test cell and located a safety shower, which he began to use. A medical and fire team were immediately dispatched to the scene and the engineers on console notified the proper authorities. The technician did receive chemical burns on his arm for which he was treated at the OHF. He was released within a few hours.

The source of the liquid MMH was a low point in the flexhose, which retained some of the liquid MMH following the eductions (proximate cause). How the liquid MMH was able to enter and collect in the flexhose low point is more complicated. The post-incident data analysis showed that the manifold drain and eduction were quite typical with no out-of-the-ordinary anomalies. However, this was the first time (at least in the memories of the engineers working the procedure) that a manifold had been drained in which the MMH was not saturated with helium. Previously, during a separate operation, the manifold had been drained and later backfilled with liquid propellant that was not saturated with helium. Helium had not been introduced into the system since the module had not flown following that operation.

When helium saturated MMH is vented to ambient and drained from a manifold, the helium that was absorbed into the fuel comes out of solution and forms bubbles which rise to the high point of the system. The bubbles expand and act as an expulsive force while the system pressure is decreasing. This helps to "push" the liquid MMH out of the manifold. When *unsaturated* MMH is drained, a capillary action takes place (this is similar to holding a finger on the end of a liquid-filled straw). The MMH does not drain from the manifold as easily and, over time, it collects at the low points as a result of in-specification leakage of the upstream manifold isolation valves. With the system pressure at approximately 23 psia, the trapped liquid fuel in the low point of the flexhose was forced out to atmosphere when the sample valve was opened. Operational human error was one root cause since the engineers were unaware of the effects that the lack of helium saturation in the manifold would cause during the drain. The following are findings and observations from the incident report:

- The flexhose had a low point in it; this should be eliminated through proper flexhose routing
 - The manifold had an inadequate drain and eduction to remove all of the liquid MMH
 - Operational human error (a root cause)
- The test team did not completely understand the ramifications of draining a system which contained unsaturated MMH
- The aspirator was not positioned properly at the valve when it was opened, as the procedure stated
- The procedure did not identify the potential for liquid MMH being released from the sample valve
 - There was no method to verify that the manifold did not contain any liquid

Reference: Sullivan

37 VAFB Titan IV A K-18 N₂O₄ Spill (7/16/1997, VAFB SLC-4E)

On July 16, 1997 engineers at VAFB SLC-4E were remotely pressurizing the two N₂O₄ propellant tanks, one each on the two Titan IV A's SRM TVC systems. Reference Figure 31-2 for a diagram of the TVC system. The propellant tank servicing was completed without incident about nine days prior to the pressurization. Each tank contained about 8,400 lbs (702 gallons) of liquid N₂O₄. The rocket was being prepared for a planned mid-July 1997 launch on a Department of Defense mission to replace an aging reconnaissance satellite. Figure 37-1 shows a Titan IV A configuration at its launch pad and points out the location of the N₂O₄ tank.

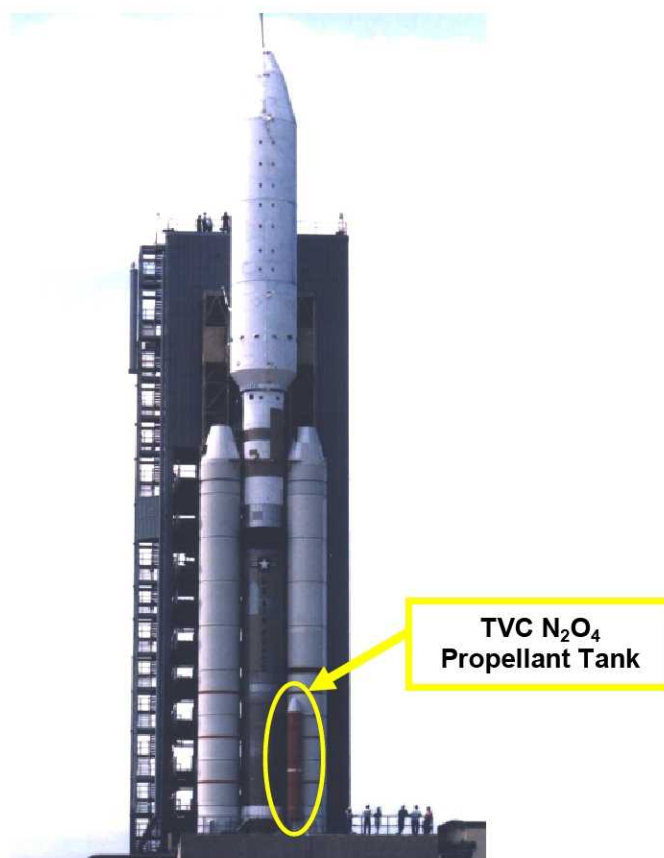

Figure 37-1: Titan IV A on Launch Pad

About 20 minutes after initiating the propellant tank pressurization, liquid N_2O_4 was observed to be streaming out of the aft skirt heat shield region on *both* SRMs. There were no reported injuries and the flight hardware had minimal collateral damage (mainly on the SRM nozzles). At the time of the observed N_2O_4 release (likely initially noticed by the signature brownish-orange NO_2 vapors characteristic of an N_2O_4 spill) the propellant tanks were at a pressure of about 830 psi. The target pressure was about 1,040 psi. The engineers quickly began to depressurize the propellant tanks, which had the immediate affect of decreasing the rate of propellant release. The tanks were vented from their initial pressure of about 830 psi to a final pressure of 38 psi, at which time the N_2O_4 release ceased. At that time, all systems were secured and the operation terminated. It was decided to offload all of the propellant from the subject tanks, so about eight hours later, the engineers and technicians began the offloading procedure. This operation was completed without incident. Following the offload and evacuation of the TVC N_2O_4 system and tubing, the total amount of propellant transferred was estimated. About 1,160 gallons of N_2O_4 was re-captured as a result of the drain-back. This logically implies that about 244 gallons of N_2O_4 was released to the atmosphere.

The source of the leak was found to be the electronic compartment purge ports on two flow control valves (FCVs) on SRM #1 and one FCV on SRM #2. A cutaway view of the FCV is shown in Figure 37-2. These valves (along with the one remaining valve that did not leak) were removed and sent to the manufacturer for failure analysis. Upon disassembly of the three failed valves, evidence of combustion was noted at the electrical compartment's omniseal. The omniseal had been extruded through the sealing surface and the retainer ring had been ejected. The degradation of the omniseal resulted in liquid N_2O_4 flowing into the FCV's electronics compartment and out the purge port. There were no leaks found within the TVC propellant tank or the associated system plumbing.

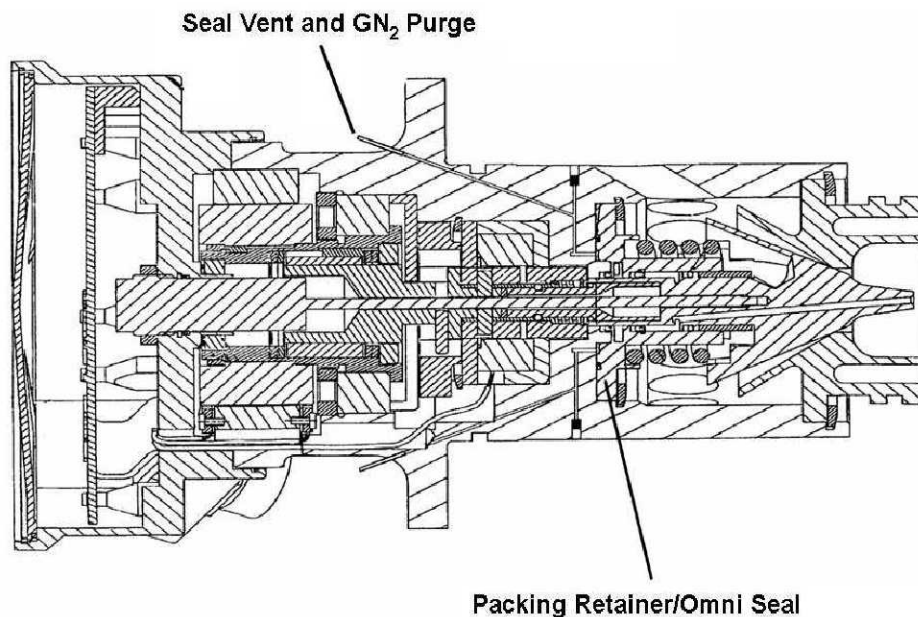

Figure 37-2: Titan IV A TVC FCV Cutaway View

Failure analysis determined that the proximate cause of the seal degradation was traced to a chemically reactive incompatibility of N_2O_4 with the cleaning agent, Bio T-200A, used on the FCVs during manufacturing at that time. Freon had long been the industry standard for oxidizer component cleaning; however, in 1987 the international scientific community endorsed the Montreal Protocol Treaty which phased out the use of halogenated hydrocarbons (including Freon) due to their proven role in ozone depletion. In early 1994, the Titan IV program adopted a policy to phase-out the use of Freon for cleaning of components and simultaneously phase-in the use of a trade product, Bio T-200A.

The Titan IV program had recently finished qualification testing and production of a new component in the Titan IV A's SRM TVC system just prior to the buildup of the K-18 launch vehicle. The new component was the FCV (four places total in the system). K-18 was the first mission with the new FCVs. Prior to K-18, the valves were an electromechanical valve (EMV), which had been used on the Titan IV and Titan III program since the early 1970s.

The component design change was driven by the difficulty in manufacturing the EMVs, as well as some of its internal components becoming obsolete. A cutaway view of the EMV is shown in Figure 37-3. The intent of the valve redesign was to make as few changes as possible to allow for consistent manufacturing, part machining, and part procurement, as well as using the same outer housing of the valve to allow the new FCV to essentially be "dropped in" without any TVC system modifications. There are several noted differences between the two valve designs. One significant difference is their method of fastening the packing retainer to the omniseals. Both designs utilize an omniseal to isolate the N_2O_4 from the valve's electronic compartment. However, the original EMV design fastened the omniseal and packing retainer using four screws, whereas the superseding FCV design employed a snap-ring to fasten the retainer. The four mechanical screws on the EMVs left a much smaller gap (if any) between the component surfaces, whereas the FCVs snap ring design, while sufficient for its launch duty, had a large enough gap between the component surfaces that the liquid Bio T-200A cleaning solvent was able to accumulate on the omniseal spring.

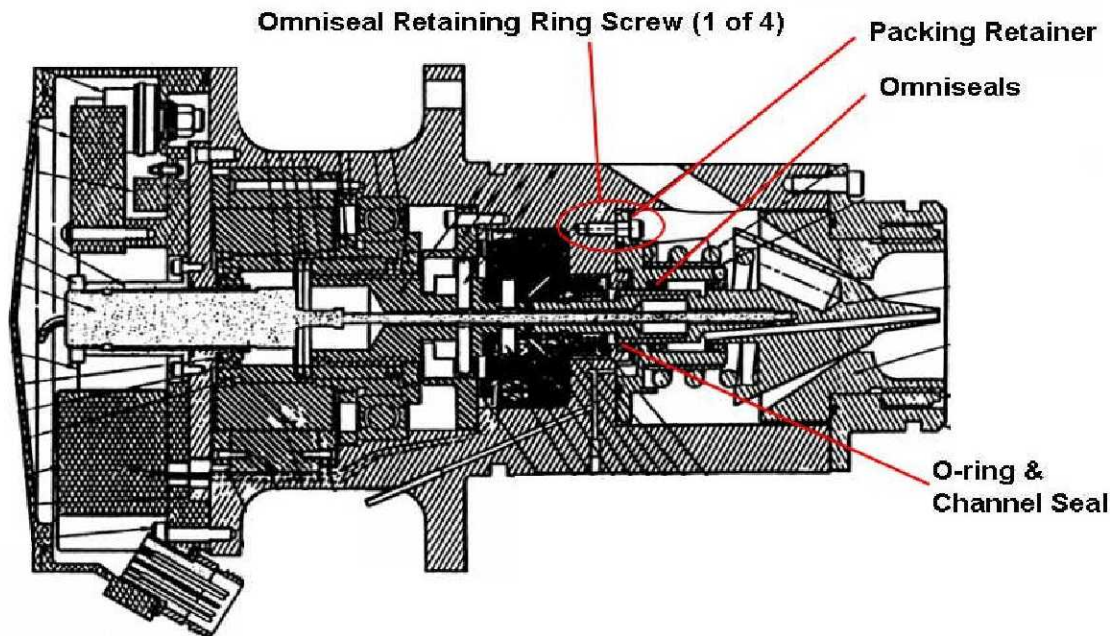

Figure 37-3: Titan IV A TVC EMV Cutaway View

A total of 74 EMVs which had been cleaned with Bio T-200A successfully flew in the Titan IV A TVC system. The Titan IV program accepted the use of Bio T-200A as the cleaning agent for the new FCVs by analysis, ground test, and similarity to the cleaning agent's use on the EMVs. The failure of three of the four FCVs on this one rocket, compared to the success of 74 EMVs on successfully launched rockets, suggests that the method of qualifying the FCVs was flawed.

In June of 1994, a subcontractor was commissioned by the FCV manufacturer to test the compatibility of liquid Bio T-200A with N_2O_4 . Tests showed that N_2O_4 reacted violently with Bio T-200A after about five hours of exposure (at ambient pressure and temperature). As a result of this finding, precautions were added in the EMV (and later the FCV) manufacturing process that included a drying out the components via a baking process since it was known that a *dry film* of Bio T-200A is compatible with N_2O_4 . The manufacturer used a 30-minute bake at 100 °F, believing that these conditions were sufficient to remove all the liquid Bio T-200A. However, Bio T-200A has a relatively low vapor pressure and thus requires a comparatively long time for complete evaporation. Following the K-18 N_2O_4 spill, an investigation identified that the FCV manufacturing process indeed left a wet residue of Bio T-200A under the packing retainer (shown in Figure 37-2).

The presumed sequence of events leading to the subject component failure was as follows:

1. By the completion of the TVC N_2O_4 propellant tank loading, the cavity adjacent to the packing retainer filled with liquid N_2O_4
2. The liquid N_2O_4 vaporized and migrated into the packing retainer crevice
3. During the tanks' pressurization, the trapped N_2O_4 vapor re-condensed into a liquid and reacted with the residual Bio T-200A in the packing retainer crevice (see Figure 37-4)
 - The energy of this reaction damaged the packing seal
 - The force of the increased system pressure overcame the remaining, compromised integrity of the seal components and thus flowed past the seals to atmosphere.

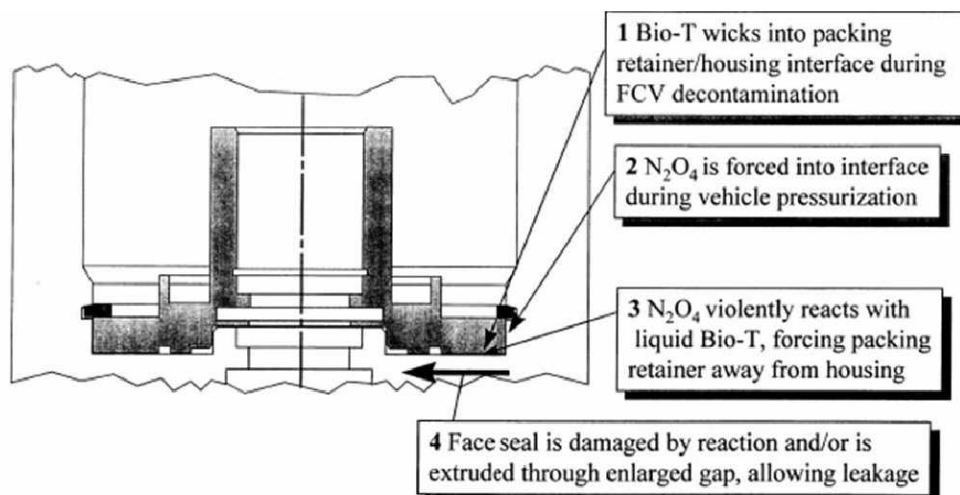

Figure 37-4: Titan IV A FCV Failure Description

The root cause of this incident was process creep. This was categorized as “Improper GSE/Vehicle Design” in Appendix C: Detailed Assessment of Incidents. The USAF noted that the process of accepting the Bio T-200A as a cleaning solvent was not well documented and appears to have been poorly managed. The chemical compatibility tests (dry film and wet residue) were not given the proper attention by the manufacturer who believed that a dry film was the only possible remnant of the Bio T-200A solvent as a result of their baking procedure.

Following the incident, use of Bio T-200A as a cleaning solvent on components in the Titan IV program was prohibited. All remaining uninstalled FCVs were disassembled, cleaned thoroughly with methyl ethyl ketone (MEK), cleaned thoroughly with Freon, reassembled, retested, and then returned to logistics. The reconnaissance satellite was launched successfully on October 23, 1997 on the Titan IV A following the replacement and retest of the four FCVs.

References: Kehler; Hill; Schindzielorz; What You Should Know...

38 Pad 39B Slope N_2O_4 Spill (11/6/1997, KSC Pad 39B Slope)

Following the oxidizer (N_2O_4) loading of Columbia for STS-87 at approximately 9:30 PM on November 6, 1997, a flange gasket (seal) failed in the Pad 39B GSE “cross country” line cross-over valve complex (the GSE lines that connect the N_2O_4 farm to the launch pad tower and vehicle). The seal failure resulted in the spilling of about 25 to 50 gallons of liquid N_2O_4 onto Pad 39B’s concrete base (proximate cause). The liquid N_2O_4 ran down the slope and contacted some live electrical cables and a small electrical fire followed. The wind direction at the time of the spill was such that the oxidizer cloud drifted away from the launch pad tower and the vehicle.

During the N_2O_4 GSE drain down following OV-102’s oxidizer servicing, the cross-over valves were closed. A water hammer effect from the liquid column in the GSE lines opened a gap at the cross-over valve flanges (inlet and outlet). This gap enabled liquid oxidizer to leak out onto the launch pad slope (the concrete incline from ground level to the base of the launch tower).

The SCAPE van driver was the first to detect the spill when he smelled oxidizer in the area of the fuel farm (see Figure 38-1 for a geographic layout of Pad 39B). Safety officials at the launch pad perimeter noted the source of the oxidizer vapors was the Pad 39B west slope. Three technicians in SCAPE were directed to proceed to the general area of the vapor source from their location on launch pad tower 107-foot level. Upon arrival, the technicians noted that heavy N_2O_4 (NO_2) vapors were leaking from both the inlet and outlet flanges of the return cross-over valve. They also noted that there were still several

gallons of liquid N_2O_4 on the ground near the flanges and at the bottom of the slope in a grassy area. Sparks were seen shortly after the arrival of the technicians; therefore, two of the three evacuated. Some of the liquid N_2O_4 that had flowed down the slope incline contacted the electrical conduits routed along the ground that supplied power to nearby lighting. The technicians were unaware that the N_2O_4 had dissolved some of the cabling insulation.

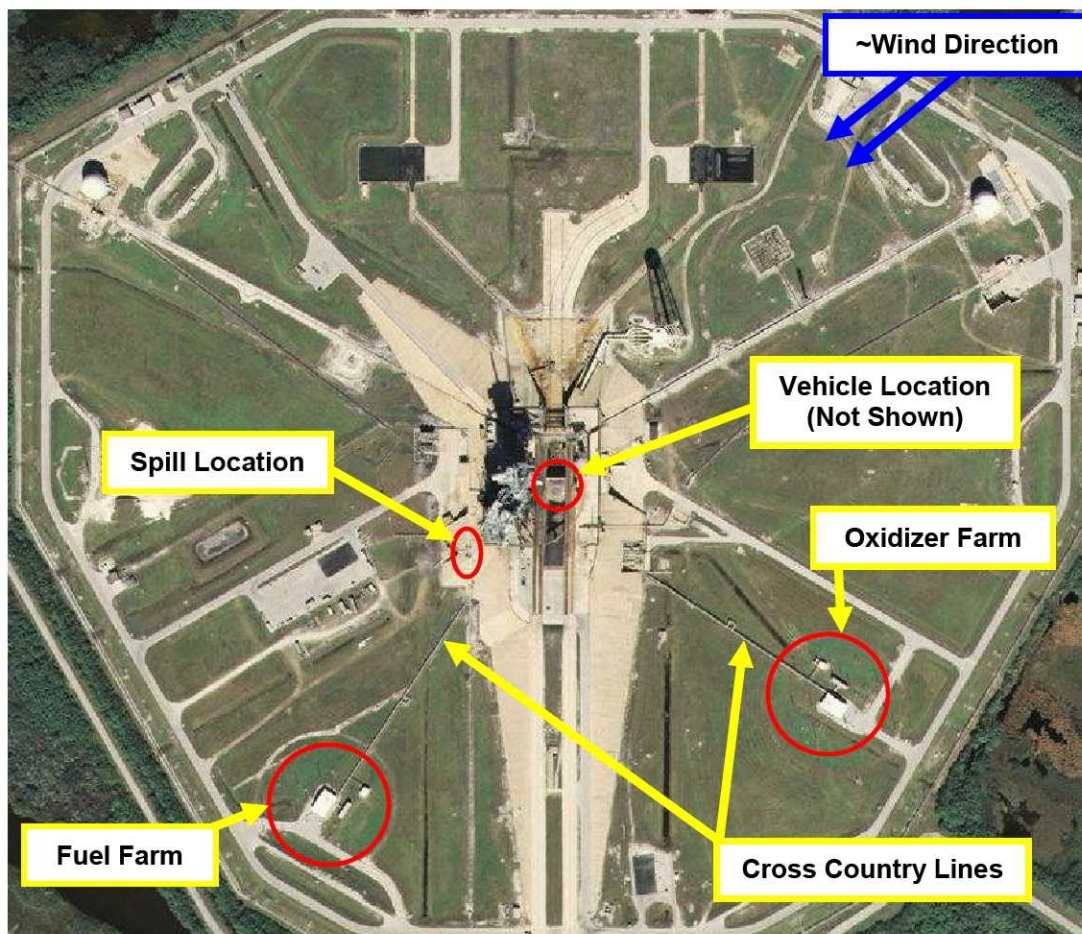

Figure 38-1: Geographic Layout of Launch Pad 39B

Since it was late at night, the technicians could not see the entire spill area very well. This was a result of the area being poorly lit during nighttime operations. Therefore, the technicians decided to activate some additional lighting at the cross-over valve complex. When power was issued to the lights there were several sparks and a small electrical fire ensued. The lights were quickly turned off and the small fire was put out with water. During the clean-up effort, one technician inhaled N_2O_4 (NO_2) vapors as a result of his SCAPE suit zipper not being secured. He was sent to the OHF and released later that night.

There was a concern that the oxidizer vapor cloud had contacted and possibly damaged the Space Shuttle stack and GSE on Pad 39B. At the time of the spill, the wind direction was away from the vehicle and launch pad in approximately a southwestern direction (034 to 053 degrees) at a speed of five to ten knots; however, detailed inspections were still completed. Thermal Protection System (TPS) engineering performed a vehicle inspection and litmus-pH test to determine if the vehicle TPS was exposed to oxidizer vapor. They verified no damage or contamination to vehicle TPS. All other engineering groups (vehicle and GSE) performed inspections and found no damage with the exception of the electrical cables on the Pad 39B slope.

About two months prior to the spill, an operation was completed on the cross-over valve complex in which the flange gaskets had to be replaced. This operation was a result of noted leaks at the cross-over valve complex return valve as a result of (it was assumed) an alignment problem with the valve flanges. The valve mounts were removed to correct the misalignment issue. The mount removal was completed without authorizing the out of configuration condition as it was against what was required per the cross-over valve drawings.

During the repair procedure, the flange gaskets were replaced; however, there was a discrepancy in the Pad 39B drawing for the flange. An engineering order had been issued in 1978 to the Pad 39A drawings to require the installation of American National Standards Institute (ANSI) sized gaskets. The Pad 39B drawings were never corrected; therefore, an undersized gasket was installed. It was also found through a detailed analysis of the flange gasket installation procedures that the flanges were not leak tested with GN₂ following the 24-hour retorquing of the flange bolts. This could have led to a change in the gasket clamping force. The combination of the undersized gasket and an inherent preload from an inadequate support structure under the valve complex (improper configuration management) were the root causes of this incident. The problem report closure statement for the spill stated the following:

“The flange gaskets which leaked were of the white gar lock material and cut to the dimensions specified per [the Pad 39A cross-country line] drawing. An investigation revealed the material of the gaskets was compatible and acceptable for oxidizer use. The apparent problem was with the dimensions specified for 150 lb flange gaskets. The internal diameter was too large, reducing the sealing surface, and a slight gasket failure led to the leak. A walkdown of the pad B [hypergol tubing] was performed and all white 150 lb gaskets were identified and replaced with gaskets cut using the new dimensions released per the [Pad 39B cross-country line] drawing...All subsequent [helium] leak checks and propellant flows showed no signs of further oxidizer leakage.”

Following this incident, the Pad 39B drawings were updated to require the installation of the proper flange seals. All the cross-over valves were removed and replaced with flanged pipe as they were no longer needed for hypergolic propellant loading. This reduced processing time on the valves and greatly reduced the risk of a leak at the valve flanges. Figure 38-2 is a photograph of the location where the cross-over valve complex was previously located at Pad 39B and Figure 38-3 is a photograph of the location of the Pad 39B fuel cross-over valve complex with the fuel farm and Vehicle Assembly Building in the background.

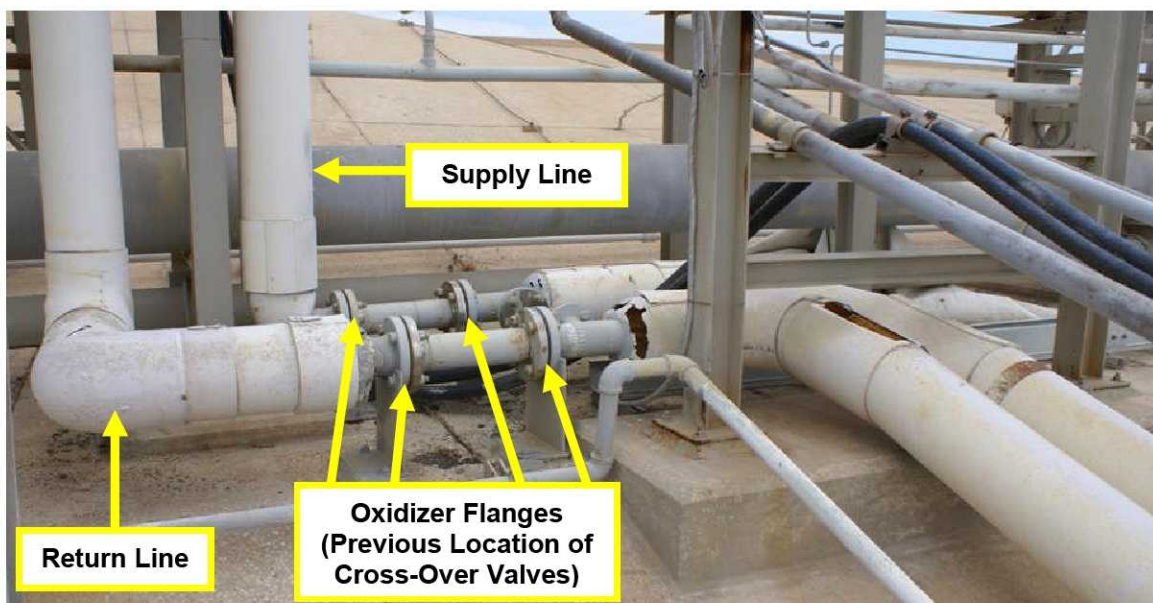

Figure 38-2: Former Site of Oxidizer Cross-Over Valve Complex at Pad 39B

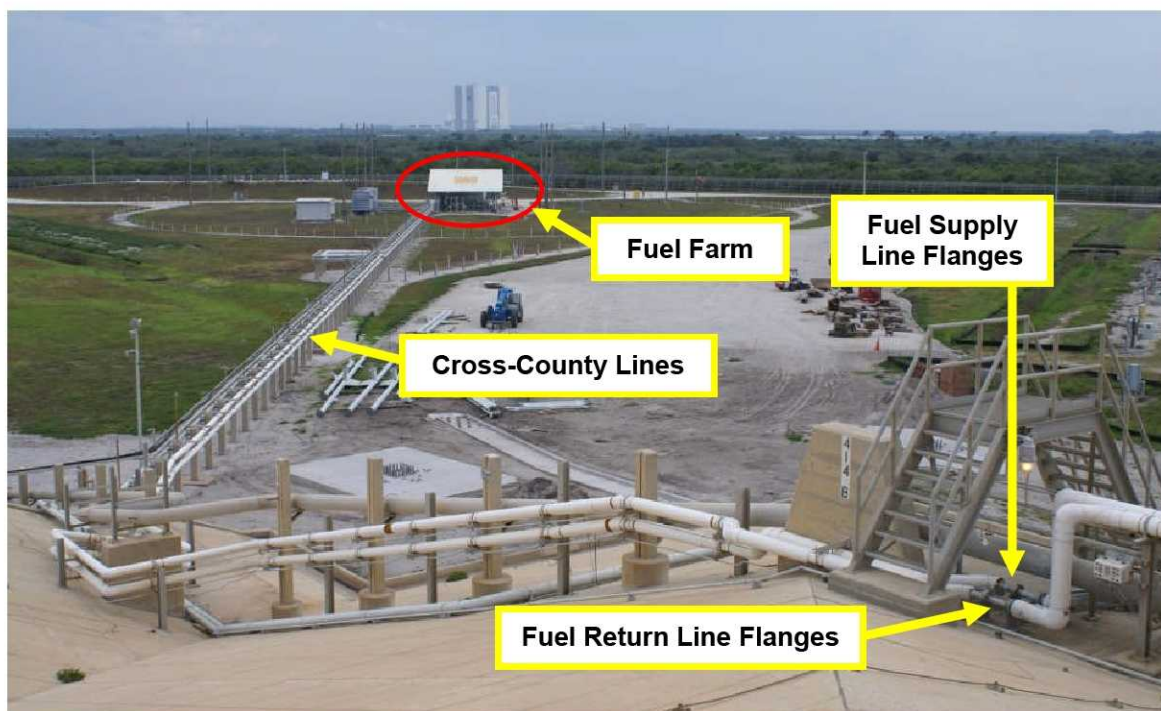

Figure 38-3: Former Site of Fuel Cross-Over Valve Complex at Pad 39A

References: KSC SSP PRACA Database (PR S70-0700-06-002-0019); Henson

39 STS-109 OV-102 APU Hydrazine Spill (8/20/1999, KSC OPF3)

During APU deservicing for OMDP in OPF3, approximately 4.5 tbsp of hydrazine (N_2H_4) spilled from a GSE flexhose that was previously connected to a high point bleed Leer-Romec AHC. The liquid dripped onto the orbiter's left hand wing inboard elevon trailing edge and the 11-foot level of OPF3. This AHC was only accessible in the orbiter aft; therefore, a flexhose had to be routed to it through an access door for testing. It was believed that the spill was a result of residual N_2H_4 leaking from the removed high point bleed flexhose that had been placed on the platform without a drip pan beneath it. There were no leaks noted during the operation prior to removal of the flexhose. The technician left the flexhose uncapped (the proximate cause) following disconnection and the hydrazine ran along the platform grating and then dripped onto the orbiter. Two tiles were removed and inspected along with the underlying structure. No damage was found on the orbiter elevon structure.

The vapor levels were checked in all of the applicable areas and all were acceptable for ferry flight closeouts (OV-102 was leaving for Palmdale, California soon after the spill). The root causes of the hydrazine spill were an insufficient GSE design in OPF3 and lack of experience by the technician that left the flexhose uncapped (improper training). This spill was the driver for implementation of new permanent GSE in each Space Shuttle OPF. The new panels were installed, calibrated, and validated in each OPF. They provide versatility as well as the additional safety of a permanent installation. The installation of these new panels substantially reduced the possibility of another APU N_2H_4 fuel spill during this procedure.

References: Gehman (CAIB Volume I finding F4.2-7 and Volume II pg 427); 1999-232-00007

40 WSTF Pathfinder Axial Engine Valve Failure (8/7/2000, WSTF TS 401)

On August 7, 2000, during the oxidizer system decontamination procedure following an engine hotfire test that occurred on August 3, 2000, an axial engine valve and N₂O₄ tubing failed (exploded) causing extensive damage to the surrounding hardware. There were no reported injuries. The volume of the spill was approximately one to two gallons mixed with several gallons of water.

Following the completion of the hotfire test near the end of the work day, the test team and customer agreed to delay the subsequent propellant sampling and decontamination until the next day (Friday). The following day it was discovered that only one person was available for sampling and the rest were out on vacation. The sampling was completed late in the day, which did not allow enough time for the decontamination procedure to take place until the following Monday.

On Monday August 7, 2000, the hardware was configured to support the decontamination procedure in which water was flushed through the propellant lines (both MMH and N₂O₄). It is usually not good practice to flush an N₂O₄ system with water as it forms nitric and nitrous acids. The procedure was performed using a TPS (Test Preparation Sheet used primarily for non-routine work) rather than a WJI (WSTF Job Instruction used primarily for repetitive, routine work). The test conductor (TC) proceeded to perform a vent of the oxidizer manifold even though this work step was not in the procedure or even necessary since the decontamination was intended to be completed with the manifold pressurized. A large NO₂ cloud was then noted at the test cell drain valve. The TC decided to not vent to MMH manifold since it would possibly mix residual propellants; therefore, he proceeded to cycle the engine valves. Following this, another "large oxidizer [NO₂] cloud was observed and a large combustion event occurred," as quoted from the WSTF report. It is assumed that the damage from this event was unnoticeable since the TC continued on after briefly stopping the test.

Regardless of the previous off-nominal events, the test team decided to proceed with the water decontamination. There was also supposed to be a nitrogen purge of the system, but the test team decided to not perform this operation. Deionized water at approximately 170 psig was introduced into the fuel lines. Shortly thereafter, the technician connected the water from the same source into the N₂O₄ propellant lines. The technician then proceeded to exit the test cell and as he did, there was another explosion. A loud bang was heard by the technician and water was observed flowing out of an unknown source from the test article. The test system was then vented remotely. The following items had either failed or were damaged:

- Failure of a cast aluminum body of the axial engine valve
- Failure and fragmentation of several 1-inch diameter 321 stainless steel hardlines
- Damage to 12-inch long, 1-inch diameter thrust ring mounting bracket
- Damage to the engine valve thrust ring mounting bracket
- Damage to support structure which was impacted by a 321 stainless steel hardline

The proximate cause for the failure was inconclusive. The most likely scenario is that MMH and N₂O₄ reacted on the oxidizer side of the engine valve (a bi-propellant valve) possibly through a Kalrez seal failure. The engine valve has redundant seals on both the oxidizer and fuel sides. In between the seals there is a small cavity with a check valve that is designed to vent propellant seepage between the seals. The reaction either propagated a shock wave into the water filled system or accelerated columns of liquid in the water and vapor filled oxidizer system. Another possible proximate cause for the failure is the removal of the vacuum conditions before the completion of the decontamination process.

Working steps out of sequence, not performing steps, and completing the decontamination procedure several days later than required (operational human error) along with performing the procedure with a TPS rather than a WJI were the root causes of this incident. Proper care was not taken with respect to procedure adherence and development.

Reference: "Investigation Report of the WSTF Peacekeeper Axial Engine Valve Damage"

41 WSTF Pathfinder Small MMH Fire (8/12/2000, WSTF TS 401)

On August 12, 2000, a procedure was underway (using a TPS) to disconnect a fuel feedline to decontaminate the Peacekeeper Pathfinder Test Article MMH system. There were two technicians in the test cell. During the disconnection several MMH drips accumulated on some nearby hardware (proximate cause of the spill). The technician began to feel a significant amount of heat on the glove of his ILC suit (similar to a SCAPE suit) and yelled "fire." A safety observer in street clothes located at the door of the test cell then entered and began to spray the two technicians with water. The second technician then grabbed the hose and began to spray down the area where the fire started, extinguishing it. There was minimal damage to the hardware and there were no injuries. The decision was made to complete disconnection of the feedline following the fire; however, the provided flange would not fit the feedline, so the operation was secured.

The proximate cause of the fuel ignition is unknown. Earlier, during the oxidizer system decontamination (see Section 40), an unexplained rupture of an oxidizer feedline had occurred on the test article. It is thought that residual oxidizer could have caused the MMH ignition, but it is uncertain. Other possibilities include rust from the test stand or static electricity as proximate causes. The root cause of this incident was operational human error as a result of the lack of oversight and careful planning following the incident on the same test article a few days earlier.

The quick reaction (albeit unsafe since he was not wearing the proper personal protective equipment) of the safety observer, likely minimized the hardware damage and prevented injury. According to WSTF Standard Instruction (WSI) PROP-0049, "The Buddy System in the Propulsion Department," the third technician should have been attired in ILC.

Reference: Gorham

42 WSTF Pressure Transducer Explosion (3/25/2003, WSTF TC 831)

On March 25, 2003, in Test Cell 831 at WSTF, during the life cycle testing of an N₂O₄ Improved Pilot Operating Valve (IPOV), there was an explosion. Following the explosion, there was an N₂O₄ vapor release (approximately three quarts) into the test cell. There were no reported injuries since the cell was vacated prior to starting the test. It was found that a pressure transducer had catastrophically failed as a result of a material incompatibility within the pressure transducer (proximate cause). Figure 42-1 is a photograph of the test setup following the explosion with the relative location of the pressure transducer prior to the explosion.

The IPOV was in the process of being validated following some modifications that were made to the valve. The operating pressure at the valve inlet was approximately 276 psia. The test was simply flowing liquid N₂O₄ from one tank into another by cycling the valve. The pressure transducer was in the system to monitor this inlet pressure. Approximately 36,000 (of the planned 80,000) cycles of the valve, with a flow duration of approximately 80 ms and a maximum flowrate of 1.91 lb/sec, had been completed when the explosion occurred. The proper emergency procedures were immediately implemented following the incident. These procedures included securing the test cell and deactivating the air handler for both the test cell and the attached building. There was no reported fire following the explosion.

Initial inspections of the pressure transducer indicated that the transducer failed as a result of one of the following: over-pressurization, inadequate design, or cyclic fatigue at a highly stressed location. Since the pressure transducer failed, data from it at around the time of the failure may be suspect; therefore, the investigation included a detailed inspection of the nearby system tubing to determine if there was an over-pressurization event. Close inspection of the pressure transducer itself would indicate if the transducer failed from cyclic fatigue or was subject to a ductile failure from a single overload event.

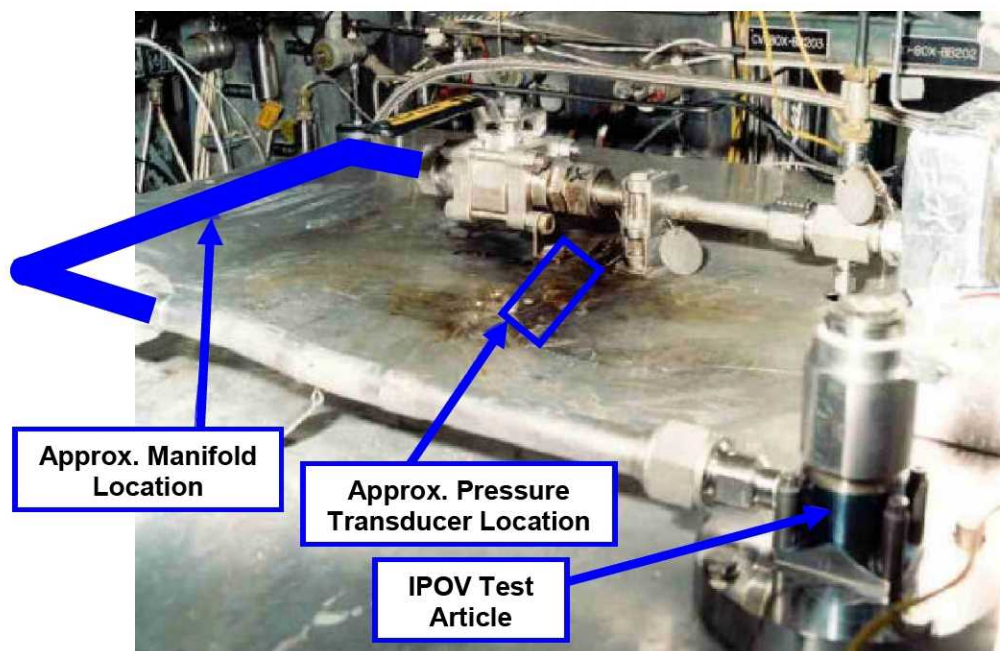

Figure 42-1: IPOV Test Setup

It was found that the pressure transducer failed at welded connection between the port (media) housing and the sensor housing. Figure 42-2 is a photograph of the pressure transducer following the explosion. It was calculated that the approximate pressure to fail this butt weld connecting the two 300 series stainless steel components was approximately 12,700 psi. It was also found that the system tubing showed no sign of yielding due to an increased pressure; therefore, the *system* pressure did not exceed the calculated tubing yield value of 3,400 psi. The pressure transducer diaphragm was found to have failed at an approximate calculated pressure of 4,000 psi. The pressure then built up very quickly in the small volume around the diaphragm and was unable to properly relieve through the 0.157-inch diameter port at the top of the transducer. This allowed the pressure in this small volume to roughly reach the 12,700 psi transducer burst pressure.

The component failure (over-pressurization) was a result of a fatigue fracture (crack) of the pressure transducer diaphragm (0.002 inches thick). This allowed silicone oil to leak into the small volume surrounding the diaphragm. Approximately 0.8 mL of silicone oil was used to fill the volume between the diaphragm and the silicon sensor. The liquid N_2O_4 reacted with the silicone oil to form nitrated phenols, including dinitrophenol and trinitrophenol (picric acid), which are shock-sensitive compounds. Some of the nitrated phenols remained between the diaphragm and the sensor, while the rest were diluted into the liquid N_2O_4 in the test system. When the IPOV was subsequently cycled, it is assumed that the shock wave in the liquid detonated the shock sensitive compounds in between the diaphragm and the sensor. N_2O_4 (NO_2) vapors were then released from the openings in the system. The vapor cloud filled the test cell and was carried by the wind through an air handler of a nearby building.

The presence of the silicone oil was not mentioned in the pressure transducer specification from the manufacturer. This is the case for many pressure transducers of this specific design. Close scrutiny of specifications during hypergol component procurement is extremely important. This incident was difficult to prevent since the WSTF personnel did not know that there was silicone oil in the pressure transducer, but an improper GSE design (component procurement) is designated as the root cause. The wind corridor was also assessed and, as a result of this incident, it was altered to reduce the risk to the surrounding buildings from an oxidizer vapor release.

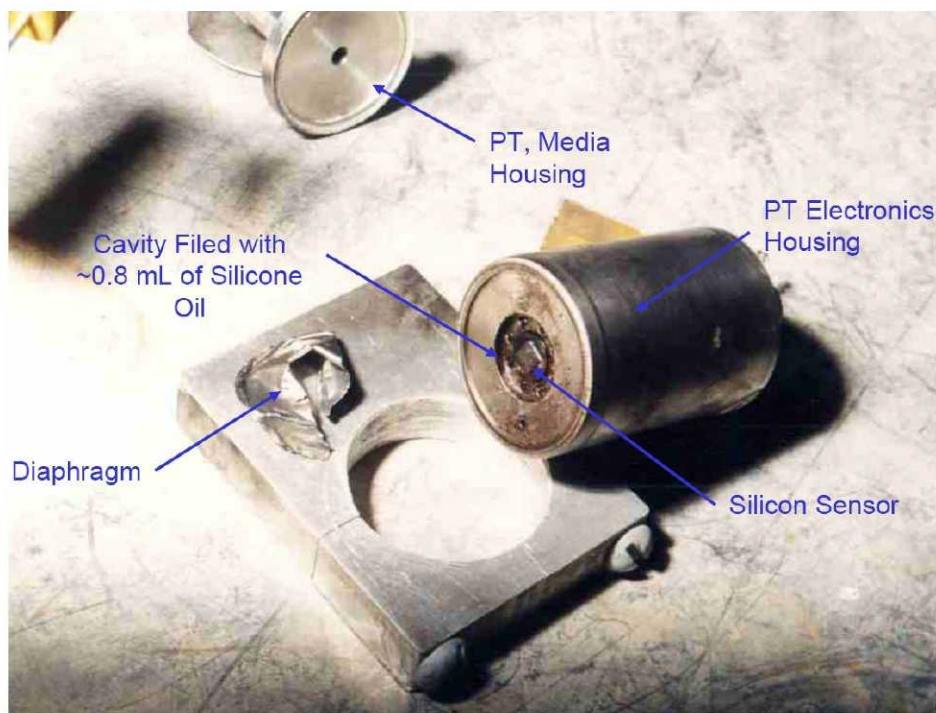

Figure 42-2: Failed Pressure Transducer

Reference: Anderson

43 Titan IV N₂O₄ Pump Explosion (8/12/2003, CCAFS LC-40)

On August 12, 2003, at CCAFS launch Pad LC-40 (shown in Figure 43-1) during the bleed-in operation for the B36 Stage II (Titan IV) propellant load, the oxidizer centrifugal pump exploded (proximate cause of the N₂O₄ spill). The Titan IV launch vehicle was being loaded in preparation for the September 9, 2003 launch of the National Reconnaissance Office's payload. Along with the liquid N₂O₄ release of approximately 40 gallons, the explosion created a large amount of shrapnel which caused significant damage to the surrounding GSE. The pump was completely destroyed as shown in Figure 43-2. Fourteen people reported to an on site health facility. They were all later released without injury. The storage tank holding several thousand gallons of liquid N₂O₄ remained intact with minimal damage. An extensive investigation was initiated as a result of the Space Shuttle Program using these same pumps at Pads 39A and 39B (eight pumps in four locations) along with the Titan program which used them at LC-40.

The engineers had noticed a decrease in the oxidizer pump flow rate (34-50 gpm versus 200 gpm) during the 18,600 gallon loading of the Stage I N₂O₄ tanks. A meeting was held to discuss this reduction in flow rate in which the contractor and government team chose to continue on with the Stage II load. The consensus of the meeting was that an internal filter had become partially clogged at the oxidizer farm. The personnel had seen this sort of occurrence previously. Operational human error is considered a root cause as a result of the loading team not investigating the decreased flow rate issue further.

Following the pump explosion, the loading team quickly removed power from the pump, closed the flow control valves at the oxidizer farm, and immediately evacuated the pad. The large NO₂ cloud that was created following the explosion was found to pose no danger to the local communities; however, a 5,000- or 12,000-foot clear (depending on the wind speed and direction) was put in place around the oxidizer farm.



Figure 43-1: LC-40 at CCAFS

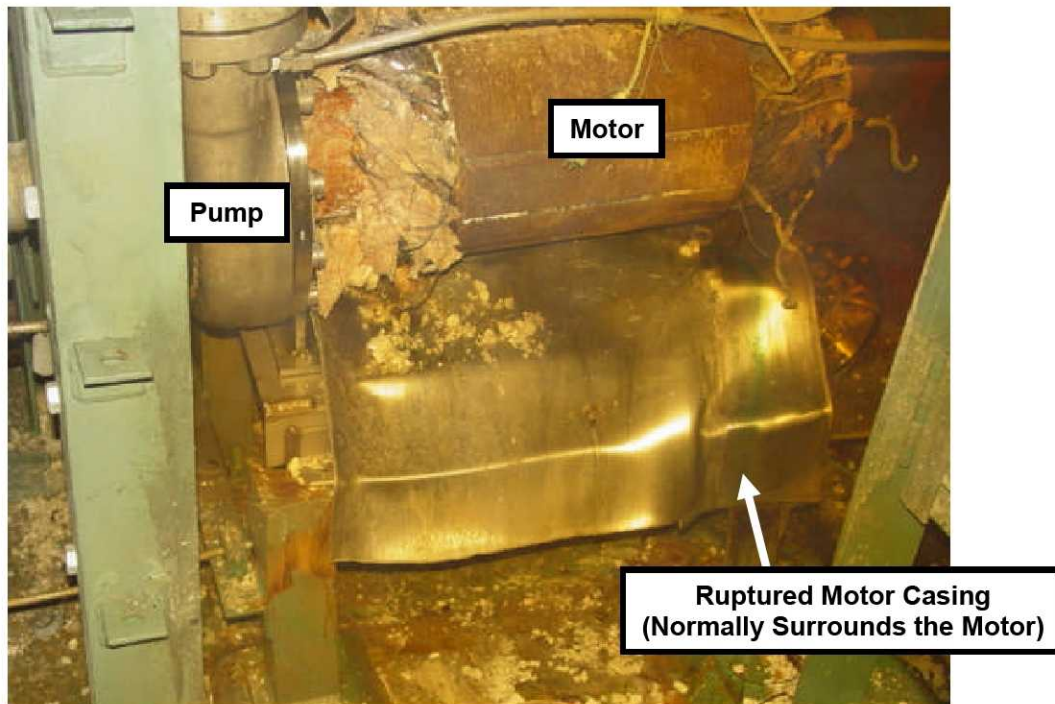

Figure 43-2: Pump and Motor After Explosion

The incident failure analysis concluded, according to Crass, that there was a “cooling anomaly at the [carbon graphite journal] bearings...leading to [an explosion] in the stator can winding area.” It was found that the most likely contributor to this was a clogged filter in the pump recirculation loop that circulates liquid through the rotor cavity to cool the front and rear bearings as illustrated in Figure 43-3. Data analysis showed that the upstream and downstream temperature transducers indicated an increase in temperature of 8 °F across the pump. The low flow rate of 40 gpm and high ambient temperatures (high of 86 °F for 8/12/2003) accelerated the failure of the pump. At these flow conditions, the pump was not

able to be properly lubricated as a result of the high vapor pressure of liquid N_2O_4 (these particular pumps are designed to be lubricated with the liquid that they are pumping). The excessive bearing wear led to damage to the stator liner can, allowing oxidizer to leak onto the hot copper windings. The N_2O_4 reacted with the copper winding insulation and caused the coil wire to short, which was the proximate cause of the explosion.

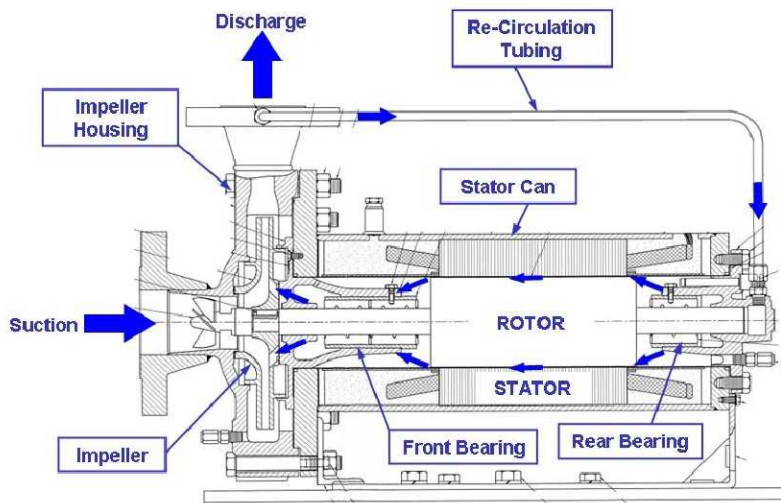

Figure 43-3: Pump Schematic

Following the explosion, there were some design changes made to the pumps since an improper pump design was a root cause, these changes include the following:

- Machining of the pump from a single billet of stainless steel rather than casting them
- Serrations were added on the impeller housing and rear bearing housing for improved sealing capability
- The addition of a thermowell for thermocouple monitoring rather than the old thermostat which proved to be unreliable

This incident encouraged the Space Shuttle Program to consider alternate pump designs for its hypergolic propellant loading system. The centrifugal pumps at Pads 39A and 39B used for Space Shuttle hypergol loading were replaced with centrifugal pumps with the design changes listed previously; however, the changes did not completely mitigate the failure mode that caused the LC-40 pump to explode. This risk was accepted by the program and engineering team; although, it was mitigated by implementing the following controls:

- Installing a blast cage around the pumps
- Reducing the pump life requirements and performing maintenance checks every 60 hours of runtime for final two launches of Titan from LC-40
- Rigorously testing the remaining pumps

And at launch Pads 39A and 39B:

- All pumps were removed and replaced following the LC-40 pump explosion
- The pumps were leak checked using a helium mass spectrometer
- A programmable logic controller was installed to deactivate the pump when the temperature reached 140 °F along with the normal health monitoring that has always been installed on the pumps

- Run-times and start/stop times were tabulated to establish a baseline for a preventative maintenance program (removal and replacement is required once every 100 hours for oxidizer and every 150 hours for fuel)
- Vibration analysis monitoring devices are installed on the pumps each time they are used
 - The data is evaluated and released in a formal report following the load

There have been four other similar occurrences (three oxidizer pumps in 1963, 1964, and 1980 along with one fuel pump in 1962) throughout the history of the Titan program. The three failures in the 1960s were a result of incompatible bearing material, which was resolved, and the failure in 1980 was a result of a pin-hole leak in the stator liner can, which was mitigated by implementing a helium mass specification leak check.

References: Crass; Comfort; 2003-224-00006

44 HMF RP01 N₂O₄ Spill (6/5/2004, KSC HMF M7-961 East Test Cell)

On June 5, 2004, at the HMF M7-961 East Test Cell, a technician was exposed to a few drops of liquid N₂O₄. The drops ran down the technician's glove and onto his left arm while attempting to reinstall a flight cap onto MD306 (RRCS oxidizer tank entry sump bleed) on RP01. The technician rinsed off his arm for about 20 minutes in a safety shower and was then sent to a local hospital. He was released later that day. There was not any reported hardware damage. The procedure included pre-operations for later testing of the RRCS helium system isolation valves, regulators, check valves, relief valves, and burst disks.

The flight cap removal procedure began with the technician completing the bleed between the flight cap and the AHC (0.0697 in³ for a ¼-inch AHC and flight cap assembly), as the procedure stated. This process had the technician install a Tygon tube to the bleed port on the flight cap and run the tube into a nearby bucket of water. The two reasons behind the flight cap/AHC interstitial volume bleed are to vent off the small volume from any N₂O₄ (NO₂) vapors that collect as a result of in-specification leakage of the poppet and to verify that the AHC poppet is not stuck in the open position. The two technicians working the operation were attired in the required PPE (hypergol compatible gloves, apron, chemical goggles, and face shield since the work was overhead). Supplied air respirators were on stand-by in case they were needed for any reason.

When the bleed port was opened, the technician noted that he saw roughly the expected amount of oxidizer bubbles in the bucket of water. The two technicians monitored the bucket for about a minute at which time they reported that the bubbles had stopped.

The technician then proceeded to remove the flight cap from the AHC (the proximate cause of the spill) at which time he noted that there was a slow liquid leak originating at the AHC poppet. The two technicians immediately upgraded their PPE to supplied air respirators and began to contain the leak with an active aspirator hose. The removed flight cap was not able to be reinstalled as a result of its degraded condition. The technicians requested a new cap be installed, which was subsequently brought into the test cell by the lead technician in street clothes. An attempt was then made to install the new cap without using the installation tool since this would require the technician to be located beneath the leaking AHC. It is claimed in the incident report that when this was attempted, the leak rate increased, as a result of a hydraulic lock from the presence of liquid between the AHC poppet and the flight cap, which had a closed bleed port. This does not seem to be realistic. The benefits of using the tool (the technician could install the cap much quicker and at an increased distance from the cap, reducing the likelihood of injury) are likely to out-weigh the risk, as long as the task was completed carefully.

On a later attempt to install the flight cap, liquid N₂O₄ ran down the glove of one of the technicians and onto his arm. It is believed that his skin was exposed to about two or three drops of oxidizer. He immediately located an eyewash station to run water over his arm for several minutes. Meanwhile, the other two technicians (one in PPE and one in street clothes) configured the aspirator hose using an

adhesive tape to contain any liquid that was released from the AHC. The three technicians then left the test cell and the exposed technician was sent to the hospital from which he was released back to work about 90 minutes later.

SCAPE personnel arrived at the scene about four hours after the initial spill. They commenced with a procedure to connect a GHC to AHC MD306. Once the GHC was connected and the test cell was verified to have a 0.0 ppm breathing zone, the cell was opened for controlled work.

The RRCS oxidizer tank was later drained for the AHC poppet replacement procedure. This operation was successfully completed. Following the spill, it was determined that roughly 1.4 gallons of N_2O_4 leaked through the MD306 poppet. The majority of this was contained using the aspirator.

The incident report claims that the exposure may have been prevented if the procedure had been written more clearly and the technicians had been more knowledgeable of the chemistry that occurs when an N_2O_4 system is vented (both possible root causes of the spill). The procedure directed the technician to vent (bleed) the volume between the AHC poppet and the flight cap for 15 seconds. The incident report goes on to say that the procedure did not specifically state that the volume should be vented for "no more than" 15 seconds; therefore, the technicians allowed the oxidizer in the interstitial volume to condense back into a liquid as a result of the dropping pressure and temperature during the vent. This theory is anecdotal and cannot be supported with any experimental or operational data. It was calculated that the leak rate of the N_2O_4 from the AHC was approximately 22.7 cc/min of liquid. This amount of liquid would have been clearly evident in the bucket of water by a trained technician even though it was later noted that the piece of Tygon tubing that was used for the operation was old (opaque).

The course of action taken following the initial spill (containing the spill as best as possible and then standing down until a SCAPE technician could continue the work) was likely the best possible solution at the time. The effort made by the technicians to reinstall the flight cap, thus containing the leaking AHC poppet, were noble; however, they put themselves at risk by installing the cap without the proper tool and completing the task without the appropriate PPE.

The most probable cause indicated in the incident report was likely not the reason for the technicians not seeing any liquid N_2O_4 exiting the Tygon tube. There is not a sufficient amount of data supporting or disputing the most probable cause presented in the report. Another possible scenario brought forth by NASA systems engineering was that the flight cap bleed port was blocked (partially or fully) by nitrate crystals that form when N_2O_4 (or NO_2) within an iron or iron alloy containment vessel is given the chance to mix with humid air and then later dry up. Proper training of the engineers and technicians was a possible root cause of this incident; however, it remains unclear what the exact mechanism was behind the spill. The flight cap was tested following the incident and it was found that GN_2 was able to flow freely through the bleed port; however, nitrates could still have been present. They could have either dissolved in the liquid N_2O_4 or were not large enough to constrict the GN_2 flow.

Improvements that were implemented following this spill include using a new piece of Tygon tubing for every flight cap bleed, inserting a loop in the tubing, and creating a consistent flight cap removal operation between the HMF, OPF, and pads.

References: Smitelli; 2004-162-00002

45 WSTF N_2H_4 Spill Following Manual Valve Failure (9/30/2005, WSTF TC 844B)

On September 30, 2005, at WSTF TC 844B during a low pressure test, a ½-inch manual valve bonnet (handle) failed catastrophically. The failure caused the valve bonnet and stem to be ejected from the assembly, thus spilling approximately 74 gallons of liquid N_2H_4 into the test cell (proximate cause of the N_2H_4 spill). Most of the liquid N_2H_4 was captured in the floor drains which were connected to a 1,500 gallon secondary containment tank; however, some was lost as vapors into the air. There were no reported injuries. Figure 45-1 is a photograph of the lower bonnet fracture surface.

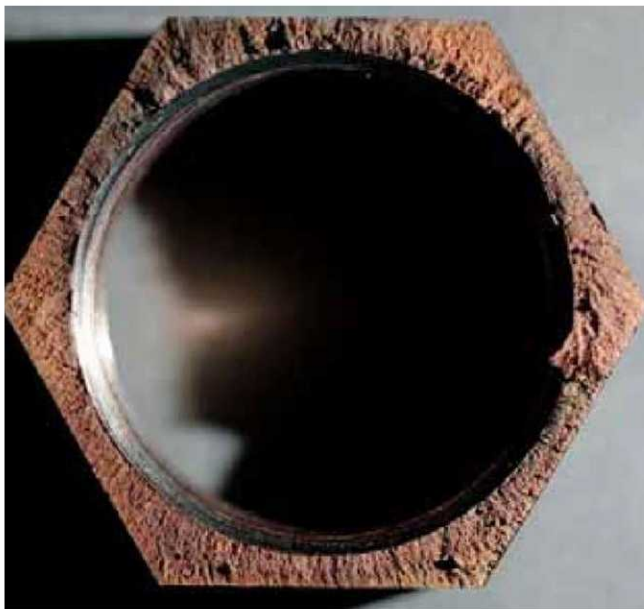

Figure 45-1: Lower Bonnet Fragment

The failure began as an intergranular crack in the nickel-plated, aluminum bronze bonnet threads (fracture surface shown in Figure 45-1). It is believed that the crack began as a result of the ethylene propylene rubber and Teflon soft seals allowing corrosive agents to slowly leak into the thread region. Figure 45-2 shows a cross-section cutaway of the manual valve. The Teflon soft seals can be seen clearly near the middle of the threaded shaft. The corrosive agents reacted with ammonia, which came from the decomposition of N_2H_4 ($N_2H_4 \rightarrow 1/3 N_2 + 4/3 NH_3$). This accelerated the local corrosion and cracking. This was the first failure for this type of valve since they were procured and installed in several hypergolic systems at WSTF in 1994.

The manual valve was used for the isolation of a leak-check leg of the “New Gas Generator Valve Module” subsystem in the Improved Auxiliary Power Unit (IAPU) system. This system is used to study long-term exposure of the IAPU to hydrazine under simulated Space Shuttle conditions.

The valve had been cycled roughly 380 times and seen approximately 177 pressure cycles at around 400 psia (the last 42 cycles were in 2005) since its installation in September of 1994. In 2005 testing began on the IAPU system using high-purity N_2H_4 (rather than monopropellant grade N_2H_4) to determine if there were any significant differences in the corresponding catalyst bed temperatures. High-purity hydrazine is defined as 99.5% pure N_2H_4 . Monopropellant grade N_2H_4 has a purity of 98.3%. During the testing, an internal leak was discovered in the system. The workaround of this internal leak was to alter the system valve configuration. The new configuration had the soon-to-be failed ½-inch manual valve in-line with the main catch tank and the bypass catch tank which resulted in a pressure of 50-psia on the manual valve that subsequently failed. While in this static configuration, the manual valve bonnet fractured and was ejected from the valve into the test cell, spilling the N_2H_4 . The altering of the nominal configuration could be considered a root cause, along with the improper design (primarily material incompatibility) of the manual valve, itself.

Immediately following the incident, the Automatic Dialing Alarm System (ADAS) began to call the responsible engineers and the WSTF fire department. The test cell was not being monitored by personnel at the time of the incident. The ADAS had detected a significant pressure drop over a short period of time in the test cell. No one was able to be reached with the automated system until the final call in the call sequence was made to the WSTF fire department. This call was made 16 minutes after the incident occurred.

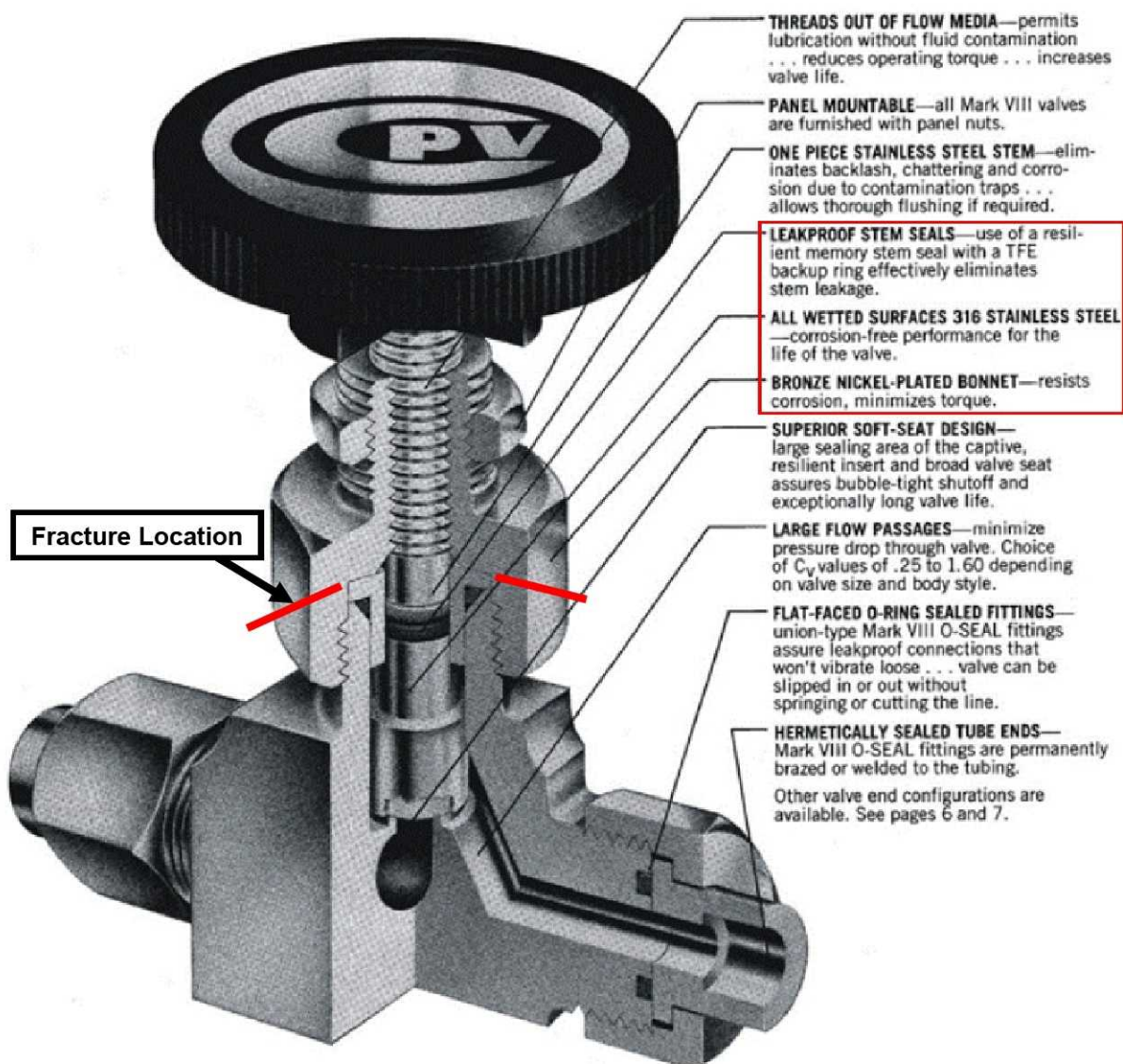

Figure 45-2: Schematic of Failed Manual Valve

The response of the personnel following the incident could have been better. However, proper steps were taken to evacuate all non-essential personnel from the area and activating the TC 844B exhaust fans about one hour after the incident following an assessment of the wind direction. Several different personnel noted that they saw smoke or vapors exiting the test cell underneath doors and out the exhaust vents. It was also noted that the vapors in the test cell were so dense that local cameras were unable to obtain a clear image. The water deluge system was only activated for three minutes (at a flow rate of 150 gpm) in the test cell (in attempt to dilute the N_2H_4) to reduce the risk of damage to the test equipment and the possibility of a fire. This added approximately 450 gallons of water to the secondary containment tank. There was no evidence of a fire or explosion during a post-incident inspection. It would not have taken much for an ignition with the reported density of N_2H_4 vapors in the test cell prior to the activation of the water deluge system. The mean temperature on Friday, September 30, 2005 was 72 °F. If it had been warmer, the outcome of this incident could have been much worse.

Test cell 844 has been exclusively an APU component test bed since 1994; therefore, it was designed for fuel only and there were no considerations for oxidizer spills. The secondary containment tank and the water deluge system were part of the overall system/facility design. Those portions of the system worked as they were intended once the decision was finally made to activate the water deluge. The containment tank was sampled and the water/N₂H₄ mixture was pumped into barrels, and sent off-site to an incinerator for disposal. There was no cleaning completed on the secondary containment tank following the N₂H₄ spill.

The incident report stated that the following items are contributing factors to the manual valve bonnet failure by environmentally assisted cracking with the final two primary bullets being the root causes (improper GSE component design):

- Intermediate stress on the nut established during valve assembly
- System loading pressure on nut
- Closing preload on nut
- Corrosive environment present at thread surface
 - Hydrazine, air, ammonia, and carbazic acid were present at the failure location
- The nickel plating on the aluminum bronze components was not as effective at corrosion prevention as advertised by the valve manufacturer
- Damaged seals allowed corrosive agents into thread region
 - Marginal triangular seal gland design
 - The ethylene propylene rubber seals degraded from long-term N₂H₄ exposure
 - The rubber seal “groove” was not large enough to hold a seal that had absorbed N₂H₄
 - Preventative maintenance/mechanical integrity plan did not consider soft good life
 - Permeation of the seals allowed corrosive agents into thread region
- Material compatibility for non-wetted components was not considered during valve procurement

The incident report stated that the following were *not* contributing factors to the failure:

- Excessive force on bonnet nut
- Cleaning solution present (mainly Oakite solutions which decompose into phosphorus oxides)
- Damage during valve assembly
- Foreign object debris present
- Over-stressing of bonnet components

Reference: Kowalski; Porter

46 STS-121 FRC3 N₂O₄ Spill (1/9/2006, KSC HMF M7-1212 West Test Cell)

On January 9, 2006, an N₂O₄ spill occurred (approximately 2.9 gallons) in the HMF M7-1212 West Test Cell on the 10-foot level. This occurred when the FRC3 AHC poppet assembly for MD122 (FRCS oxidizer propellant tank lower compartment channel bleed) was being removed and replaced (proximate cause). Two technicians were evacuated from the building and sent to the OHF following the scent of N₂O₄ in their SCAPE suits. Two other involved technicians were sent to the OHF as a precaution. It was determined that all four had no injuries. It was also determined that the SCAPE suits had not failed (e.g. they did not have any holes in them). There was notable damage to flight hardware and ground support equipment in the test cell. Several PRs were opened during the cleanup process on the following systems: TPS, TCS, STR, OHE, ORH, and OEL/INS.

A few opinions were brought forth as to the possible cause of the spill. It is unknown if one single event caused the liquid to fill the MD122 line and spill into the M7-1212 west test cell or if it was a combination of several different events. Operational human error was designated as the root cause of this incident as a result the engineering team incorrectly predicting the response of the vehicle system during the removal and replacement procedure.

With the vehicle in a horizontal orientation, the MD122 line runs from the high point of the oxidizer tank lower compartment channel, through an interface at the tank outlet flange, and out to an AHC located in an externally accessible door on the FRCS outer mold line (AP28-00 door). It is known through pressure measurements that the MD122 and MD120 connected GSE lines were clear of any liquid immediately following the two, five-minute purges; however, it is not known if the propellant acquisition system channel in the lower compartment was broken down (i.e. it did not contain any liquid). If the screen was not completely broken down, it is possible that liquid oxidizer “wicked” up the screen following the purges to the point where MD122 connects to the acquisition screens. See Figure 46-1 for visual aid of the propellant acquisition system screens and the MD122 line. The absence of liquid in the lines can be confirmed by noting that there was not any significant pressure increase in the lines. The tank was *not* in thermal equilibrium. The tank shell (skin) temperature rose from 49 °F, when tank venting was complete, to 58 °F, when MD124 GSE vent valve was opened for the emergency vent through MD124 in the upper compartment of the tank. When the two purges were complete the tank shell temperature was 54 °F. From the time of the spill to the emergency MD124 vent, the tank shell temperature rose from 57 °F to 58 °F. The fluid and gas temperatures likely rose by a degree or two during this time.

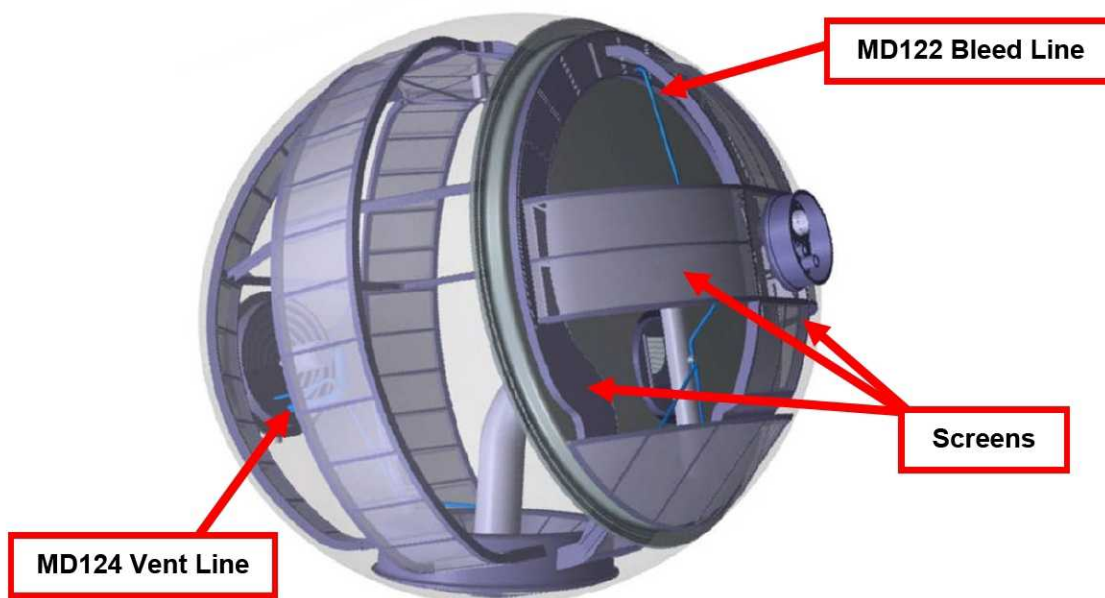

Figure 46-1: Solid Model of RCS Propellant Tank in (Roughly) the Horizontal Orientation

At the time of the spill there were three pressure transducers online for use. All three pressure transducers indicated no change until just after 12:29 PM when the oxidizer tank out pressure toggled down 1.6 psi from 14.4 psia to 12.8 psia. The venting of the tank through MD124 took place at 12:27:24 PM. This, however, does not mean that the tank pressure was not in flux. As a result of the coarse data resolution, the oxidizer tank out pressure could have been changing within a range of +/- 1.6 psi.

Prior to the spill, it was determined through x-ray analysis that the N_2O_4 propellant tank contained 19.5 gallons of N_2O_4 . Following the spill, it was determined that 2.9 gallons of N_2O_4 had been lost through the venting process and the spill itself.

In the hours and days following the spill many problems were reported as a result of the N_2O_4 (NO_2) vapors reacting with different materials on the Space Shuttle forward module. A photograph of the module following the spill is shown in Figure 46-2. Damage to the Koropon structural coating can be seen along with a couple of missing thermal tiles. A total of ten thermal tiles (highlighted in yellow in Figure 46-2) were later removed and replaced before the perimeter of the spill was bounded. Other PRs were taken to assess issues with wiring and Neoprene adhesive wraps that are used to attach wires to

tubing and are known to react with N_2O_4 (NO_2) vapors and cause corrosion on stainless steel tubing through chloride attack.

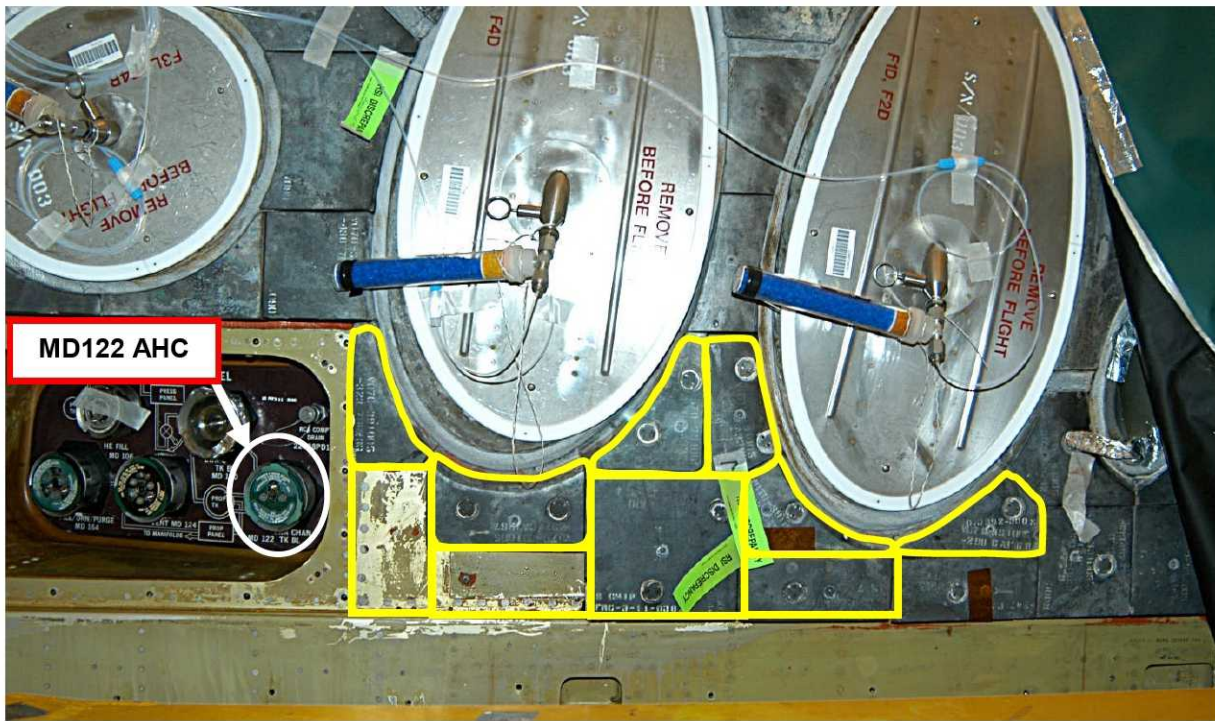

Figure 46-2: FRC3 Following Spill (Replaced Tiles Highlighted in Yellow)

The spilled oxidizer appears to have reacted with Koropon, RTV, and silver plating (nutplates and barrel nut elements). The oxidizer vapors reacted with the Koropon and removed a large area, as shown in Figure 46-3, and passed through the nutplate holes and around the perimeter of the phenolic QD service panel into the interior of the FRCS module, as shown in Figure 46-4, causing damage to the Koropon on the interior side of the FRCS module.

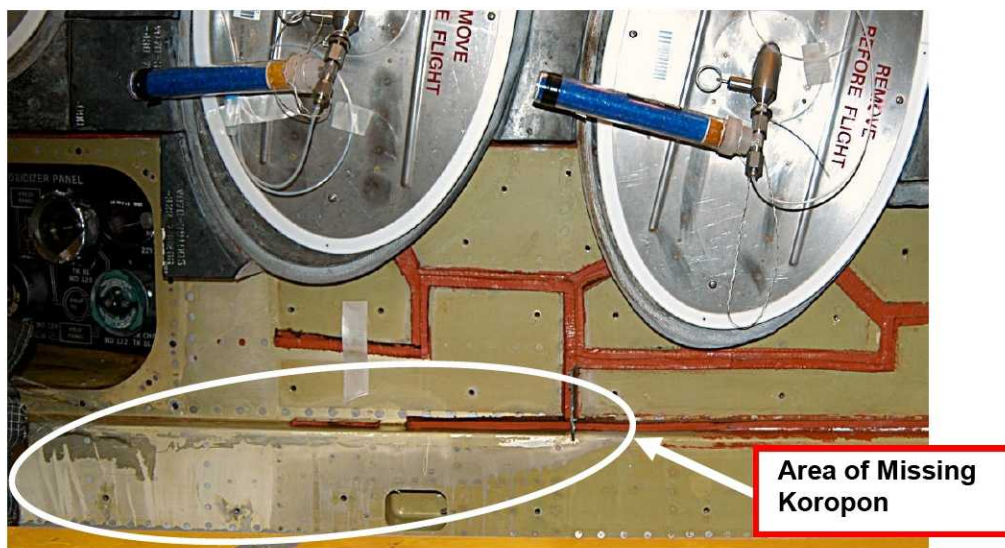

Figure 46-3: View Looking at R/H Side Down-Firing Thrusters (F2D & F4D)

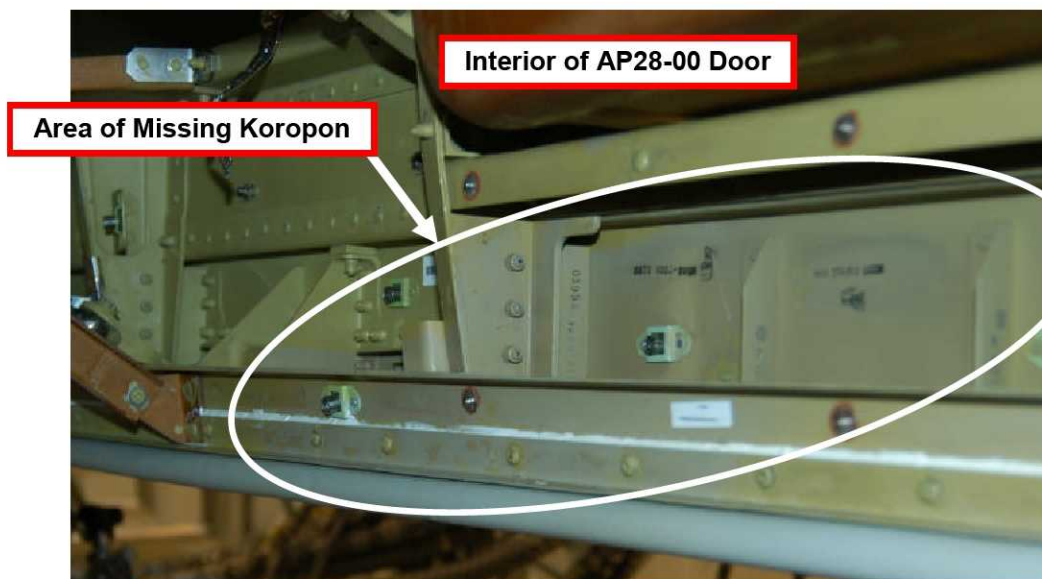

Figure 46-4: Koropon Damage on Interior of FRC3 Below AP28-00 Door

The spill also caused damage to a few thermal blankets located within the FRCS module. The primary visible effect on TCS blankets when exposed to N₂O₄ (NO₂) vapors is the degradation of the thin metallic foil coating. Depending upon the amount of exposure, this effect can be delayed. The blankets were evaluated two days after the spill occurred, and three blankets were identified as contaminated. These blankets were removed. The remaining blankets were evaluated later with further degradation noted.

A report was put together by HMF USA OMS/RCS engineering management following the input from a four-panel-member board, which included one NASA representative. The purpose of the report was to summarize the spill event and form recommendations to improve processes in the future. Two findings and five observations were noted in the report. A summary of the findings/observations and recommendations are tabulated in Table 46-1. Following the table are several observations put forth by NASA OMS/RCS engineering.

Table 46-1: Committee Report Findings/Observations and Recommendations

<u>Finding/Observation</u>	<u>Recommendation</u>
Procedure was reviewed and alternative purge processes were discussed in house by NASA/USA engineering system experts.	Evaluate and develop alternative methods to reduce risk of liquid release. Evaluate process for independent review of complex hazardous tasks using the First Article Review Process.
Failure to develop contingency plans in the event of unexpected liquid release.	Include Emergency Procedures for unexpected liquid release.
Personnel reported smell of oxidizer in SCAPE suit and reported to the test team. Each member of the test team directed the potentially exposed employee to leave the work area. Employee egressed after the third request to leave the test cell. An employee in the relief SCAPE crew stated later that he smelled oxidizer in his SCAPE suit, but failed to report it to the test team.	Brief individuals involved in the SCAPE operation on the proper response to possible hypergolic contamination inside the SCAPE suit. Re-emphasize training in removing individual from contaminated area, (squat and squeeze), report anomaly, depart area, perform individual change out, and maintain the buddy system.

<u>Finding/Observation</u>	<u>Recommendation</u>
Multiple occurrences of SCAPE discipline breakdown; breathing air was not maintained either by air bottle or hardline and communication between SCAPE personnel and test team was not maintained.	Management to brief individuals involved in the SCAPE operation on the importance of maintaining positive breathing air and communications at all times.
Test Team evaluated the hazardous conditions and determined the safest course of action was to complete the entire operation, including the clean-up of released oxidizer prior to mishap evaluation. Unexpected oxidizer release was reported to Safety Console and HMF Management. Witness statements and data collection commenced without delay, and were completed by the end of shift.	Conduct Post Test review and evaluate test team's actions for compliance of a USA operating procedure related to Reporting, Investigating, and Resolving Mishaps.
Test team performed an engineering risk assessment during the development of the outline and table top reviews however failed to document per the SFOC Risk Assessment process.	Review First Article TOP development process.
Spill Protection did not adequately contain quantity of defined credible spill and failed to protect adjacent hardware from oxidizer release.	Evaluate Spill protection process and develop desk instructions to ensure proper level of spill protection corresponds to reasonable risk of release.

Observation 1 – QC and Safety Presence During Disposition Development

Quality and safety were not involved in the preliminary disposition meetings.

Observation 2 – Verification Ruling Out the Presence of Liquid Not Pursued

The addition of a sight glass into GSE to positively rule out the presence of liquid N₂O₄ in the fluid lines might have been beneficial. If not the sight glass, there should have been some other verification method or procedure that took place to ensure that there was no liquid present in the lines prior to the disconnection of any hardware.

Observation 3 – Low Pressure Purges

The purges were completed at 2-4 psig because, at the time, it was thought that the requirement of 4.6 psid across the tank bulkhead (solid structural interface between the tank's upper and lower compartments) would be violated. This was actually not true because any increase in pressure would be relieved through either the compartment transfer tube or the vent through MD120. The propellant tank screens test purge procedure, which is very similar, called for 30-40 psid for no less than (NLT) five minutes. A separate PR, in which MD120, MD122, and MD124 AHCs were rebuilt and MD120, MD122, and MD178 tank fittings were removed and replaced used a purge pressure in through MD122 and out MD120 of 4-8 psid for ten minutes.

Observation 4 – Purge Lengths

It would probably have been advantageous to do the two purges for longer than five minutes. The propellant tank screens test purge length was NLT five minutes, but it was often done for ten or even fifteen minutes and the FRC5 PR mentioned in Observation 3 required a purge time of ten minutes.

Observation 5 – Spill Protection

The spill protection in the area around the AP28-00 door was inadequate and not capable of containing the maximum credible spill quantity.

Observation 6 – Aspirator and Vent Linked to Same System

The aspirator utilizes nitrogen flow that exits to the vent system, thus increasing the vent system's pressure. This could lead to vent gas migrating into the vented flight propellant tank; however, this has not been proven. There is concern that this would introduce moisture into the oxidizer tank thus increasing the likelihood of damage to tank components through corrosion.

Observation 7 – Hypergol Exhaust Fans Were Not Used

The M7-1212 West Test Cell hypergol exhaust fans were not used following the spill because of a concern that the tank isolation valves would back relieve some unknown amount of liquid into the lower compartment of the tank as a result of temperature increases in the test cell. It was believed that this increase in cell temperature would cause a pressure increase in the lines between the tank isolation valves and the thruster valves (the manifold isolation valves were open). The actual amount of liquid that would have been back relieved was later found to be approximately a few cubic inches of liquid N₂O₄. In hindsight, use of the exhaust fans in the event of a spill should have been studied in detail and discussed at the table-top meetings during the procedure development and communicated to the test team during the pretest briefing.

Observation 8 – Emergency Safing

There was no pre-planned provision that enabled closing of the AHC should the need arise, as in this instance.

Since the spill occurred, a very similar procedure was successfully completed on forward module FRC3 again. Engineers and technicians completed the procedure review and operation with the lessons learned from the 2006 FRC3 spill in mind.

References: Nufer; Keinath; 2006-027-00002

47 Conclusion

Many hypergolic related incidents have been discussed. A quick summary of the incidents mentioned previously can be seen in Appendix B: Summary of Incidents. Some common lessons learned deduced from the various root causes are shown in the following list. If these items were properly addressed prior to the incidents, prevention may have been possible (in hindsight) or the impact or consequence of the incident could have been reduced.

- Improper configuration control and internal or external human performance shaping factors can lead to being falsely comfortable with a system
 - Vent systems are often neglected and treated as non-hazardous even though they can capture and contain hypergolic liquids (especially in low points)
 - Aging support hardware should be routinely inspected to reduce the risk of a failure during critical operations
- Communication breakdown can escalate an incident to a level where injuries occur or hardware is damaged
- Improper propulsion system and ground support system designs can destine a system for failure
 - Low points in GSE should be designed out
- Improper training of technicians, engineers, and safety personnel can put lives in danger
 - Inadequate knowledge of electrostatic discharge while working fuel operations can lead to a fire or explosion
 - Knowledge of transducer offsets is very important for system oversight
 - Unknown incompatibilities (from lack of training or research) with propellants can cause surprising failures
 - **If an incident does occur, the system should immediately be placed into a stable configuration; following this, the procedure should be stopped to assess the problem and its possible ramifications**

- A heightened amount of situational awareness of technicians and engineers working operations can reduce the risk of an incident and decrease the possibility of injuries or damage if an incident does occur
- Improper PPE, spill protection, and staging of fire extinguishing equipment can result in unnecessary injuries or hardware damage if an incident occurs
- Improper procedural oversight, development, and adherence to the procedure can be detrimental and quickly lead to an incident
 - Improper emergency procedures can increase the risk of injuries or hardware damage
- Improper local cleanliness or housekeeping (for example iron oxide or rust) can result in fires or explosions
- A thorough hypergol system evacuation should be completed (wherever a vacuum is tolerable by the system) prior to the removal or disconnection of any hypergolic propellant fittings
 - A pulse purge has proven to be inadequate for the removal of residual propellants

Table 47-1 and Figure 47-1 summarize the fuel and oxidizer incidents. Note that if the numbers in the table are totaled, they do not sum to the total amount of fuel and/or oxidizer spills summarized in this document. This is a result of some incidents having injuries and a fire or multiple root causes, for example. A larger, more extensive list of the data shown in Table 47-1 can be seen in Appendix C: Detailed Assessment of Incidents.

Table 47-1: Hypergol Spill and Fire Summary

Oxidizer Incidents:

- 23 Total (Liquid and Vapor)
- 7 Vapor Only
- 3 Led to a Fire
- 3 Led to an Explosion
- 8 Led to Injuries (minor to death)
- 12 Led to Hardware Damage

Fuel Incidents:

- 24 Total
- 8 Led to a Fire
- 2 Led to an Explosion
- 7 Led to Injuries (minor to death)
- 12 Led to Hardware Damage

10 Oxidizer/Fuel No Hardware Damage or Injuries

Root Causes:

- 7 Procedure Adherence/Control (engineer or technician did not follow procedure or protocols were ignored)
- 11 Improper Personnel Training (engineers or technicians were untrained or too inexperienced)
- 17 Human Error (technician and/or engineers making a real-time error)
- 24 Improper GSE/Vehicle Design (improper materials, unknown low points, incompatibilities, etc.)
- 11 Improper Configuration Management (system configuration and upkeep errors that led to an incident)

Incident Occurred During:

- 18 During Commodity Movement
- 15 During an R&R Procedure
- 41 During a Nominal Hypergol Operation
- 13 During Opened Hypergol System
- 3 In a Static Hypergol System

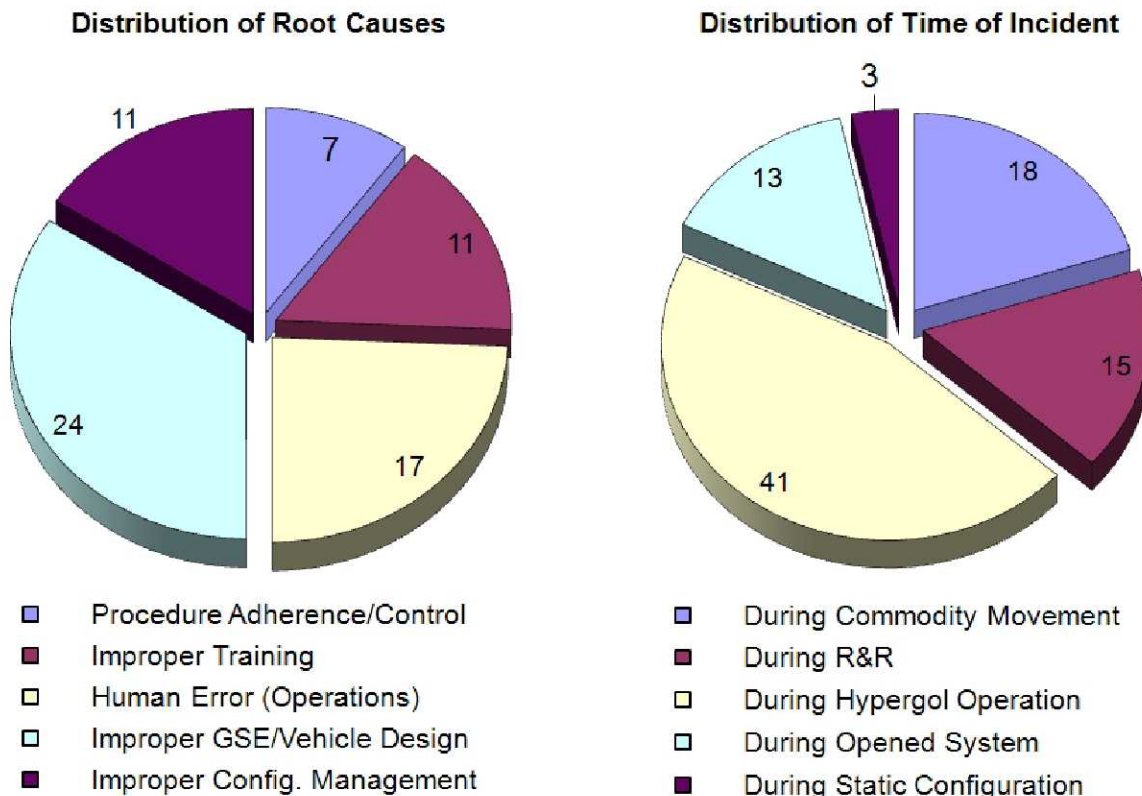

Figure 47-1: Distributions for Root Cause and Time of Incidents

Some lessons learned from the Apollo program related to hypergol loading equipment according to J. Tribe include:

- On-board vehicle instrumentation was limited to that required for flight evaluation; this dictated use of GSE instrumentation to monitor critical vehicle parameters during ground operations—a less than desirable configuration
- Operational visibility from the control room was minimal and there was extensive reliance on technicians (usually in SCAPE) to read gages correctly and position multiple manual valves
 - The servicing and test disconnects on the command and service module (CSM) were challenging to manually position correctly
 - This inevitably led to a mis-configuration on Apollo 16 that resulted in a CM RCS tank ruptured bladder, roll back of the Saturn V stack and de-stack of the CSM and lunar module; lack of flight system instrumentation was a direct contributor to this event
- As the design matured, configuration changes increased complexity for ground operations and greatly extended servicing timelines
 - SM RCS changes from individual block 1 “quads” to block 2 to the propellant storage module installation are an example (8 tanks to 16 tanks to 25 tanks)
 - Each “quad” was a stand-alone system until the propellant storage module interconnected them
- Multiple individual tanks on CSM required multiple access panels and disconnects
 - Compare:

	<u># of tanks</u>	<u># of servicing panels</u>	<u># of disconnects</u>
CSM Skylab	31	22	56
Shuttle OMS/ARCS	8	2	22
 - This multiplicity resulted in a complex ground servicing operation with an extensive fluid distribution system, valve boxes, bleed units, ullage cylinders, purge panels and the need for a weather-protected 360 degree access

- Apollo servicing operations required a variety of loading methods – mostly sequential and time-consuming
 - SPS fill used on-board gauging/totalizer to determine flight loads
 - RCS fill used a combination of evacuated tanks with load by weight and fill to overflow, removal of a specified ullage and a manual PV determination to confirm flight loads
 - Flight loads were accurate but the methods were time-consuming
- During the life of the program, significant propellant spills (especially during Apollo 7 preps) drove increased need for spill collection and containment
 - The installation of improved scuppers at vehicle interfaces and facility precautions were complex and time-consuming
- Different fuels for different flight systems (A-50 and MMH) doubled the number of servicing units and fluid distribution systems
- The Space Shuttle Program corrected many of these deficiencies with
 - Remotely controlled operations from the LCC
 - Extensive use of software loading programs
 - Remotely operated disconnects and leak checks
 - Gang servicing valve disconnects for OMS and ARCS

Some type of human error can be traced to nearly every studied incident as a root cause, whether it be an error in the design phase or an error prior to or during operational use of hardware containing hypergols. Humans are most definitely not perfect and even when the most knowledgeable personnel are intimately involved in the design phase (vehicle or GSE) or during an operation, mistakes can be made and critical items can be overlooked. One can deduce, however, that most incidents happen during some sort of dynamic operation. Hypergols tend to be very stable in a static configuration (as long as the compatibility characteristics have been well addressed). At the end of the day, an appropriate quote related to the majority of hypergolic spills and fires comes from the 9/11 Commission Report, “The most important failure was one of imagination.”

Advance warning (prior to any liquid or vapor release) was available in several of the incidents to the technicians in the vicinity of the spill and/or the engineers that were monitoring from a remote location. The warning indications include off-nominal data (remote or local), off-nominal system characteristics, and/or local changes that occurred without human intervention. Some of these went unnoticed or were ignored during the operation, thus resulting in an incident. There was advance warning in 19 out of 38 total incidents (50% of the time). This percentage does not include spilled fuel as an advance warning of a fire (5 occurrences). Depending on the local environment, there is a reasonable probability that if hydrazine (or one of its derivatives) is spilled, there will be a fire; therefore, the fuel spill itself is an advance warning of a fuel fire. Roughly 42% of the fuel fires documented in this report resulted in a fire or explosion. The Titan IV K-9 N₂O₄ spill likely had an advance warning; however, there was no one in the vicinity of the indications to receive the warning, therefore, this was not included in the above percentage along with the OV-101 APU spill in 1977, since it was unable to be determined if there was an advanced warning for this incident. Located in Appendix B: Summary of Incidents is a summary of the advance warnings for each incident (if there was one).

Hypergolic rocket propellants have proven to be a highly reliable asset in manned and unmanned space flight; however, their maintenance on the ground has proven to be relatively difficult. Do the operational risks from possible human errors or hardware failures causing a catastrophic incident outweigh the usefulness of hypergols even though they have been used for the last 50 years of manned and unmanned spaceflight? One would have to say probably not, since hypergols are so widely used in the space industry currently and are being proposed to be used on many vehicles in the future. Therefore, ground operations on hypergol systems have become increasingly scrutinized for possible unknowns, and rightfully so. The data shown in this report are not an example of why we should not be using hypergolic propellants on spacecraft and launch vehicles, but rather what we can and should do to mitigate possible unforeseen ground operation and/or design problems.

48 References

- Anderson, John C. "Test Cell 831 Druck Pressure Transducer Failure on March 25, 2003." Johnson Space Center, White Sands Test Facility Laboratories Office. Investigative Report Number WSTF-IR-0185-001-03. May 5, 2003.
- Applewhite, John B. "Update on L3D Removal Incident." Informal email. May 31, 1995.
- Apollo (ASTP). Wade, Mark. 1997-2007. Encyclopedia Astronautica. <<http://www.astronautix.com/flights/apooastp.htm>>.
- Banke, Jim. "Shuttle's Leaking Line Gets Finishing Touches." Florida Today. August 19, 1988, 1st edition: 4A.
- Banke, Jim and Ann Mittman. "NASA Explores Shuttle Options." Florida Today. July 19, 1988, 1st edition: 1A+.
- Baum, B. "Impact Sensitivity of Chem Pump Stator Materials After Oxidizer Exposure." Martin Marietta Corporation Inter-Department Communication 0483/81-32. January 28, 1981.
- Benson, Charles D. and William Barnaby Faherty. "Moonport: A History of Apollo Launch Facilities and Operations." NASA Special Publication-4204. 1978.
- Benz, F. J. and M. D. Pedley. "A Comparison of the Explosion Hazards of Hydrazine and Methylhydrazine in Aerospace Environments." CPIA-PUB-455, Volume 1, pp 477-488. 1986.
- Bowman, H.D. "Oxidizer Leak/OPF High Bay 2, 17 Feb. 84 at 0945." Interdepartmental Communication. 2301-84-021HDB. February 18, 1984.
- Buzzard, Frank et. Al. "NASA Management Briefing of OV-105 R1A Thruster Fire Mishap." Presentation slides given by NASA Investigation Board. May 18, 1995.
- Comfort, James L. "ORB Minutes – SLC-40 Oxidizer Farm Pump Incident." Memo for 45 OG/CC, Department of the Air Force, Patrick AFB, FL. August 14, 2003.
- Cotton, R. K. "Pad A Monomethylhydrazine (MMH) Fuel Farm Mishap." Lockheed Space Operations Company Mishap Investigation Board Investigation Report. January 21, 1986.
- Craig, Anna F. "Procedure for Connecting, Disconnecting and Maintaining the Cleanliness of Forward Reaction Control Subsystem and Aft Propulsion Subsystem Disconnect Couplings." The Boeing Company Specification. ML0310-0032 Rev. G. February 21, 2002.
- Crass, Larry, Art Geer, Steve Cronau, and Mark Maccan. "SLC-4E Blast Cage Modifications/Ox Pump F/A Results." Baker Engineering & Risk Consultants. ERB 03-2076R1. December 16, 2003.
- Delventhal, R. A. and N. M. Faget. "Space Shuttle RCS Oxidizer Leak Repair for STS-26[R]." NASA Johnson Space Center. Document ID 19900009169. May 1, 1989.
- Demarchi, E. N. "Hydrazine Leak – Ov-101 Aft Fuselage Wiring." Rockwell International Internal Memo 392-620-77-619. October 3, 1977.
- Dougert, Robert S. "RE: Hypergolic Spill/Fire Report." E-mail to Robert Dougert. May 18, 2009.
- Draus, Thomas. Branch Chief, Shuttle Hypergolics, Hydraulics, & Auxiliary Power Branch. NASA Kennedy Space Center. Personal interview. July, 21, 2008.

- Ezell, Edward C. and Linda N. Ezell. "The Partnership: A History of the Apollo-Soyuz Test Project." NASA SP-4209. 1978.
- "Fire, Explosion, Compatibility, and Safety Hazards of Hypergols – Hydrazine. American Institute of Aeronautics and Astronautics Special Project Report. AIAA SP-084-1999. 1999.
- "Fire, Explosion, Compatibility, and Safety Hazards of Hypergols – Monomethylhydrazine." American Institute of Aeronautics and Astronautics Special Project Report. AIAA SP-085-1999. 1999.
- "Fire, Explosion, Compatibility, and Safety Hazards of Nitrogen Tetroxide." American Institute of Aeronautics and Astronautics Special Project Report. AIAA SP-086-2001. 2001.
- Fisher, James and John J. Glisch. "Leak Could Put Discovery on Shelf." The Orlando Sentinel. July 17, 1988, 1st edition: A-1+.
- Fisher, James. "Shuttle May Go Back to Hangar for Repair Work." The Orlando Sentinel. July 19, 1988, 1st edition: A-3.
- Gehman, Harold W. Jr et al. "Columbia Accident Investigation Board Report Volume I." August, 2003.
- Gehman, Harold W. Jr et al. "Columbia Accident Investigation Board Report Volume II." October, 2003.
- Glisch, John J. "Shuttle Tank Problem May Not Have Had Thorough Check." The Orlando Sentinel. July 20, 1988, 1st edition: A-1+.
- Gorham, Richard. "MMH Fire at Test Stand 401." Honeywell Technology Solutions Inc. Memorandum. PD00-096. August, 21, 2000.
- Hall, George F., Raymond Lake, John H. Storm, and Ross J. Utt. "Fire Protection Research and Development Requirements Analysis for USAF Space Systems and Ground Support Facilities Volume I – Fire Protection Operational Requirements Analysis." Flight Dynamics Directorate Wright Laboratory Air Force Materiel Command, Tyndall Air Force Base, FL. WL-TR-96-3010. April, 1995.
- Hartsell, Heather. "Top Story – Titan Missile Crisis." The Arkansas Leader. September 27, 2006. <http://www.arkansasleader.com/2006/09/top-story-titan-missile-crisis_27.html>.
- Heinrich, Manfred M. United Space Alliance Chief Engineer, KSC. Personal Interview. September 17, 2007.
- Henderson, J. "Fuel Waste Incident Report." WSTF Internal Memo. February 21, 1990.
- Henson, D. M. "Hypergolic Oxidizer Spill." IERB 0003-98. December 8, 1997.
- Hill, Gary et. Al. "FCV Vent Port Leakage." Titan IV SRM Program Technical Interchange Meeting. Meeting briefing log number 7260. July 31, 1997.
- Houston, D. W. "MMH Spillage Investigation." Rockwell International Laboratory Test Report LTR 3406-4579. October, 1981.
- "Investigation of the WSTF 400-Area Oxidizer Spill Incident." Johnson Space Center, White Sands New Mexico, Las Cruces New Mexico. March 29, 1996.

- "Investigation Report of the WSTF Peacekeeper Axial Engine Valve Damage." WSTF-MR-00-0004. Lyndon B. Johnson Space Center, White Sands Test Facility, Las Cruces New Mexico. September 15, 2000.
- Johnson, B. H. "Failure Analysis of a Fluid Mechanics Check Valve from Orbiter Processing Facility (OPF) Toxic Vent System." NASA Engineering Development, Ground Support Office, Materials Analysis Office, Malfunction Analysis Branch. MAB-221-86. September 30, 1986.
- Kamp, G. J. "N₂O₄ Release at Oxid Farm IPR-6V-1189." Memorandum for the Record. February 10, 1983.
- Kehler, Robert C. "30 SW Operations Review Board Minutes." Memo for 30 SW/CC, Vandenberg AFB, CA. August 22, 1997.
- Keinath, Richard. "Flash # 008214 – Hypergolic Maintenance Facility (M7-1212) Oxidizer Spill." Investigation Committee Slides. March 10, 2006.
- Kersey, Judith. "Independent Assessment of the OV-103 OMS/RCS Pod Leak and OMS Pod Processing." KSC IAI 0988-01. NASA Kennedy Space Center, Florida. February 13, 1989.
- Kolcum, Edward H. "NASA Managers Scramble to Limit Leak's Impact on Discovery Launch." Aviation Week & Space Technology. July 25, 1988: 24-25.
- Kowalski, Robert R. "Test Cell 844 Manual Valve Failure Mishap Investigation." NASA Propulsion Test Office, Johnson Space Center, White Sands Test Facility. WSTF-MR-05-0005. March 14, 2006.
- KSC Hazard Report. "Personnel Injury and Flight Hardware Damage Resulting from SRB Hydrazine Leak or Spill." Report Number SPC-K13167-86 Rev. B. September 2, 2002.
- KSC Hazard Report. "Possible Fuel/Oxidizer Vapor Release During Maintenance/Calibration of Relief Valves on the MMH/N₂O₄ Storage Tank." Report Number SPC-K12186-85 Rev. A. May 22, 2006.
- KSC Incident Reporting Information System (IRIS) Database. Incident Numbers: 1985-144-00001, 1986-021-00001, 1986-210-00001, 1999-232-00007, 2003-224-00006, 2004-162-00002, 2006-027-00002. 2008.
- KSC SSP PRACA Database. "During Attempted Removal of Adapter from Throat of Thruster Liquid Spilled from Thruster R4D." PR RP04-9-08-0031 (page 1A). Initiated May 24, 1985.
- KSC SSP PRACA Database. "Fuel Waste Barrel Inadvertently Filled With Fuel (MMH). Suspect FV-2 Valve Inadvertently Opened By Lifeline for Traffic in Area." PR HMFE-0299. Initiated December 12, 1990.
- KSC SSP PRACA Database. "FV-1 and FV-2 Valve Handles Extend Into Walk Area and May Be Inadvertently Cycled on the Fuel FCU." PR C72-1631-03-001-0015. Initiated March 4, 1991.
- KSC SSP PRACA Database. "Liquid MMH Released from Sample Valve at I/F A94209 After Drain and Evacuation Procedure Completed; S/B No Liquid." PR FRC4-19-0470. Initiated March 26, 1997.
- KSC SSP PRACA Database. "Oxid [N₂O₄] Cross Country Line Pressure is Decreasing, Indicating an External Leak." PR S70-0700-06-002-0019. Initiated November 6, 1997.
- KSC SSP PRACA Database. "Small Flame Reported When Sample Gear Was Removed from A78626 Sample Valve N₂O₄ Drain When F/H Was Removed Came in Contact With Insulation Which Burned Momentarily." PR PADB-0209. Initiated June 24, 1988.

Lance, Renée J. "Approach and Landing Tests Auxiliary Power Unit Subsystem Flight Report." January, 1978.

McCoy, R. W. "January Interim Report: LT-152 Fire Investigation." EG & G Florida Interoffice Correspondence 631-5-008. January 15, 1985.

MER Problem Report (STS-9) STS-9-V-26. November 26, 2007. MER Problem Tracking Database. July 11, 2008. <<http://mer.jsc.nasa.gov/merptd/Public/Home.cfm>>.

Meyer, R. R. "Incident Report: Aspiration of Oxidizer into the Fuel Aspirator System at Test Stand 401." Lockheed Engineering & Sciences Company Interdepartmental Communication. PTD90-119. March 29, 1990.

Myers, Jeffrey, M.D. "RE: Hyper Spills & Accidents Lessons Learned Report – Toxicology of NO₂ Inhalation." E-mail to Jeffrey Myers and Frank Golan. August 7 2008.

National Aeronautics and Space Administration. "Project: Apollo 7 Press Kit." Release No: 68-168K. September 27, 1968.

Nufer, Brian M. "FRC3 HMF Building M7-1212 West Test Cell FRC3 N2O4 Spill on January 9, 2006." Incident Summary Report. May, 2006.

"Occupational Exposure to Hydrazines." NIOSH Criteria for a Recommended Standard. U.S. Department of Health, Education, and Welfare (DHEW), Public Health Service, Center for Disease Control, national Institute for Occupational Safety and Health (NIOSH). DHEW (NIOSH) Publication No. 78-172. June 1978.

Olney, J. N. "OV-101 Hydrazine Exposure Investigation." Rockwell International Laboratory Test Report LTR 2291-4466. March, 1978.

Perez, Conrad. "RE: Apollo 7 Spill." E-mail to Conrad Perez. June 24, 2008.

Porter, Alan R. "RE: 2005 N2H4 Spill Questions." E-mail to Alan Porter and Kurt Rathgeber. May 29, 2008.

RCS Thruster Heater Power During Ferry Flight Stopovers. Kline, James G. June 2, 1994. NASA Lessons Learned Website. Lesson Learned Entry 0059. August 1, 2007. <<http://nen.nasa.gov/portal/site/llis>>.

Rathgeber, Kurt A., Bruce Havenor, and Steven D. Hornung Ph.D. "Hypergol Systems: Design, Buildup, and Operation." NSTC Course 055. January 6, 2006.

Reynaud, Raymond. "Lessons Learned – Quick Disconnect (QD) Oxidizer Exposure Incident." QARSO-WSTF Informal Memo. November 20, 1992.

Rodgers, James L., Maj., USAF. "Titan Oxidizer Leak ORB." Memorandum for Record for the Department of the Air Force, 45th Space Wing (AFSPC), Patrick AFB, Florida. September 16, 1994.

Sargent, Douglas E. "MMH Spill Mishap Report (January 21, 1986)." Lockheed Space Operations Company Internal Letter. July 3, 1986.

Schindzielorz, Howard. "Titan IV-A FCV Vent Port Leakage TIM." Memorandum for Record for the Department of the Air Force, 45th Space Wing (AFSPC), Patrick AFB, Florida. July 31, 1997.

Skaja, Jeffrey T. "RE: Titan IV N₂O₄ Spill on CCAFS." E-mail to Jeffrey Skaja. September 4, 2008.

Smitelli, Joseph III. "HMF Oxidizer Exposure." Standing Accident Investigation Board Team Report IPB-04-025-D. June 5, 2004.

Stefanovic, Mike et. Al. "OPF Bay 2 Fuel Spill." Mini-Investigation Report. February 17, 1997.

Sullivan, J. L. "HMF FRCS #4 Fuel Spill." Formal Accident Investigation Board Report. KSC Mishap Report Number USK-97-020. March 26, 1997.

Titan-II.com. Currie, George. September 9, 2007. July, 11, 2008. <www.Titan-II.com>.

Titan II Missile Explosion. 2008. The Encyclopedia of Arkansas History and Culture. The Central Arkansas Library System. July 11, 2008. <<http://www.encyclopediaofarkansas.net/>>.

Torpey, Tom. "Situational Awareness" course notes. NASA Safety Training Center Course Number 034. January 18, 2006.

Tribe, J. "Apollo Hypergolic Systems-Command and Service Modules." December 2007.

Tribe, J. "Incident/Error Review Board Item 70 – Inadvertent Flow of MMH to Atmosphere Resulting in Ignition/Fire on June 29, 1982." Rockwell International Internal Letter. L0-JT-82-044. October 29, 1982.

Tribe, J. "Incident 029-83, MMH Spill During FRCS Ferry Plug Removal." Rockwell International Internal Letter. L0-JT-82-043. May 2, 1983.

Utsman, T. E. "Monomethylhydrazine (MMH) Spill/Fire, June 29, 1982." NASA Internal Memo. VO/Director of Shuttle Operations. Undated.

Walker, J. J. "Evaluation of Materials for N₂O₄ and Aerozine 50 Compatibility for Chemical Pumps." Martin Marietta Corporation Mechanical Engineering Materials Engineering MeME 81/273R. September, 1981.

Washburn, J. F. "Final Report of the Fire Involving Hypergolic Fuel (MMH) Tanker LT-152." KSC-E-863. August, 1984.

Weber, D. A. "Reported Fire During OV-105 L3D Thruster Changeout." Lockheed Martin Space Operations Interdepartmental Communication. June, 12, 1995.

What You Should Know about Refrigerants When Purchasing or Repairing a Residential A/C System or Heat Pump. August 25, 2008. Ozone Layer Depletion – Regulatory Programs. U.S. Environmental Protection Agency. August 26, 2008. <<http://www.epa.gov/Ozone/title6/phaseout/22phaseout.html>>

Wilder, J. "Release of Oxidizer Vapor During Flight Cap Installation on MD338." Rockwell International Internal Letter. L0-JW-81-010. July 14, 1981.

Wilder, J. "Incident Report LC-39A." Rockwell International Internal Letter. L0-JW-81-011. July 15, 1981.

Williams, Wiley E. "LC-39A STS-2 Oxidizer Leak." Mishap Investigation Committee Final Report. October 9, 1981.

49 Appendix A: Acronyms and Abbreviations

ACGIH TLV-TWA	American Conference of Governmental Industrial Hygienists Threshold Limit Value Time Weighted Average
ADAS	Automated Dialing Alarm System
AFB	Air Force Base
AHC	Air Half Coupling
Al	Aluminum
ANSI	American National Standards Institute
APU	Space Shuttle Auxiliary Power Unit
ARCS	Space Shuttle Aft Reaction Control System
CAIB	Columbia Accident Investigation Board
cc	Cubic Centimeters
CCAFS	Cape Canaveral Air Force Station
Cp	Commercially Pure (in reference to Titanium)
Cr	Chromium
Cres	Corrosion Resistant Steel
CSM	Command and Service Module
DOT	Department of Transportation
EAFB	Edwards Air Force Base
EMV	Electromechanical Valve
°F	Degrees Fahrenheit
F#Letter L#Letter R#Letter	Space Shuttle Thruster Reference Designator (F means FRCS, R means RRCS, L means LRCS; middle number is the manifold; and the last letter is the thruster direction D (down), U (up), L (left), R (right), F (forward), or A (aft))
FCV	Flow Control Valve
FRC#	Space Shuttle Forward Reaction Control Module Number #
FRCS	Space Shuttle Forward Reaction Control System
ft	Foot
gpm	Gallons Per Minute
GSE	Ground Support Equipment
GHC	Ground Half Coupling
GN ₂	Gaseous Nitrogen
HMF	KSC Hypergolic Maintenance Facility
HNO ₃	Nitric Acid
HONO	Nitrous Acid
HPU	SRB Hydraulic Power Unit
HTH	High Test Hypochlorite(industry trademark)

IAPU	Improved Auxiliary Power Unit
ICBM	Intercontinental Ballistic Missile
IPR	Space Shuttle Interim Problem Report
ILC	International Latex Corporation Suit (similar to SCAPE suit)
INS	Space Shuttle Instrumentation
IRIS	Incident Reporting Information System
JSC	NASA Johnson Space Center
KSC	NASA Kennedy Space Center
lb(s)(m)	Pounds (mass)
LC	Launch Complex
LCC	KSC Launch Control Center (also called "the firing room")
LP0#	Space Shuttle Left OMS/RCS Pod Number # (LP01, LP03, LP04, LP05 {destroyed STS-107})
LPS	KSC Launch Processing System
LRCS	Space Shuttle Left Pod RCS
LSOC	Lockheed Space Operations Company
LV01	Original Left OMS/RCS Pod of the Space Shuttle (destroyed STS-51L)
MD###	Manual Disconnect Number # from Space Shuttle OMS/RCS
MEK	Methyl Ethyl Ketone
MER	JSC Mission Evaluation Room
MLI	Multi-Layer Insulation
MLP	KSC Mobile Launch Platform
MMH	Monomethylhydrazine
MON	Mixed Oxides of Nitrogen (N ₂ O ₄)
N ₂ H ₄	Hydrazine
N ₂ O ₄	Nitrogen Tetroxide
NASA	National Aeronautics and Space Administration
NIOSH	National Institute of Occupational Safety and Health Recommended Exposure Limit
REL	Nitrogen Dioxide
NO ₂	No Less Than
NLT	NASA Procedural Requirement
NPR	Outer Diameter
OD	Space Shuttle Orbiter Electrical
OEL	Space Shuttle Orbiter Handling
OHE	KSC Occupational Health Facility
OHF	KSC Operational Intercommunication System
OIS	

OMDP	Space Shuttle Orbiter Maintenance Down Period (long duration down-time for detailed repairs and testing)
OMI	KSC Operations and Maintenance Instruction (permanent, heavily scrutinized, and regularly ran work instruction)
OMS	Space Shuttle Orbiter Maneuvering System (6000 lb thrust rockets)
OP	Operating Procedure
OPF	KSC Orbiter Processing Facility
ORH	Space Shuttle OMS/RCS HMF
ORSU	WSTF Oxidizer Ready Storage Unit
OSHA (PEL)	Occupational Safety and Health Administration (Permissible Exposure Limit)
OTV	KSC Closed Circuit Television
OV-####	Space Shuttle Orbiter Vehicle (OV-099 was Challenger, OV-101 was the Enterprise test vehicle, OV-102 was Columbia, OV-103 is Discovery, OV-104 is Atlantis, and OV-105 is Endeavour)
P	Pressure
PPE	Personal Protective Equipment
ppm	Parts Per Million
PR	Problem Report
PRACA	Problem Reporting and Corrective Action (used for tracking Space Shuttle problems)
PRCS	Space Shuttle Primary Reaction Control System (870 lb thrust rockets)
psi(a)(d)(g)	Pounds Per Square Inch (atmospheric) (delta) (gage)
PVC	Polyvinyl Chloride (form of plastic)
QC	Quality Control
QD	Quick Disconnect
R	Rankine
R&R	Remove and Replace
RCS	Space Shuttle Reaction Control System
RFHCO	Rocket Fuel Handler Coverall Outfit (similar to a SCAPE suit)
RP0#	Space Shuttle Right OMS/RCS Pod Number # (RP01, RP03, RP04, RP05 {destroyed STS-107})
RRCS	Space Shuttle Right Pod RCS

RTF	Space Shuttle Return to Flight (Post STS-51L and STS-107)
RTV	Room Temperature Vulcanization (adhesive)
RV01	Original Right OMS/RCS Pod of the Space Shuttle (destroyed STS-51L)
SCA	Space Shuttle Carrier Aircraft
SCAPE	Self-Contained Atmospheric Protection Ensemble
SFOC	Space Flight Operations Contract (NASA contract with USA)
SIP	Strain Isolator Pad
SLC	Space Launch Complex (also referred to as LC)
Sn	Tin
SPS	Service Propulsion System
SRB	Solid Rocket Booster
SRM	Solid Rocket Motor
SS	Stainless Steel
STR	Space Shuttle Structures
STS	Space Transportation System
T	Temperature
TC	Test Cell
TCS	Space Shuttle Thermal Control System
Ti	Titanium
TLV	Threshold Limit Value
TOP	Technical Operating Procedure
TPS	Space Shuttle Thermal Protection System
TPS	Test Preparation Sheet (temporary work instruction)
TS	Test Stand
TTA	JSC Thermochemical Test Area
TVC	Thrust Vector Control
TVC	Toxic Vapor Check
TWA	Time Weighted Average (reference TLV)
UDMH	Unsymmetrical Di-Methylhydrazine
USA	United Space Alliance
USAF	United States Air Force
USSR	Union of Soviet Socialist Republics (former Soviet Union)
V	Vanadium
VAFB	Vandenberg Air Force Base
Vp	Vapor Pressure
WC	Tungsten Carbide
WJI	WSTF Job Instruction
WSI	WSTF Standard Instruction
WSTF	NASA JSC White Sands Test Facility

50 Appendix B: Summary of Incidents

The preceding table is a summary of all the credible spills and fires included in this report along with their respective dates, locations, a short description, and primary lessons learned.

<u>Incident</u>	<u>Date</u>	<u>Location</u>	<u>Description</u>	<u>Advance Warning</u>	<u>Primary Lesson(s) Learned</u>
Apollo 7 SPS N ₂ O ₄ Spill	Sept. 1968	CCAFS LC-34	Inadequate purges resulted in the collection of liquid N ₂ O ₄ in a tubing low point, technician was removing a panel when about 1-2 gallons of liquid N ₂ O ₄ spilled onto the vehicle and surrounding structure, some vehicle damage, no reported injuries	None	Spill protection is necessary in a hypergolic propellant transfer operation, do not attempt to dilute liquid N ₂ O ₄ with water, and tubing low points should be eliminated from GSE in the design phase
Apollo-Soyuz Astronaut N ₂ O ₄ Vapor Exposure	7/24/1975	Apollo-Soyuz Test Project Apollo Command Module Reentry	During reentry the astronauts performed a few tasks out of sequence leading to ingestion of N ₂ O ₄ (NO ₂) vapors into the crew module	None	Performing tasks out of planned sequence can lead to unexpected results
OV-101 APU 1 Cavity Seal N ₂ H ₄ Spill	6/28/1977	During second captive-active test flight of Enterprise	Approximately 5 gallons of N ₂ H ₄ spilled onto the side of the vehicle and in through the vent doors when a shaft seal failed, some flight hardware damage	Unknown if the leak resulted in a pressure drop visible in the cockpit or from the ground	Kapton and N ₂ H ₄ are not compatible, some components of the APU system were redesigned
Titan II Silo Large Scale N ₂ O ₄ Spill	8/24/1978	McConnell AFB Silo 533-7	The worst known N ₂ O ₄ spill in U.S. history where approximately 13,450 gallons of liquid N ₂ O ₄ spilled into a missile silo killing 2 and injuring 25, caused by o-ring seal lodging in AHC poppet, filter was missing from system to catch the o-ring	None	Proper configuration control of GSE components, in this case the filter, is highly important in the handling of toxic chemicals especially hypergols
N ₂ H ₄ Spill Following APU Hotfire	Nov. 1979	KSC OPF1	N ₂ H ₄ dissolved brass in a "gauge saver" spilling a couple gallons of N ₂ H ₄ , no reports of injuries or damage	None	Unknown incompatibilities can lead to surprising spills during an operation or while in a static configuration

<u>Incident</u>	<u>Date</u>	<u>Location</u>	<u>Description</u>	<u>Advance Warning</u>	<u>Primary Lesson(s) Learned</u>
Titan II Explosion Following A-50 Spill	9/18/1980	Little Rock AFB Silo 374-7	A technician dropped a large socket 70 feet, it bounced into the Titan II rocket piercing the A-50 propellant tank, spilled about 11,140 gallons of fuel which later ignited causing the N ₂ O ₄ propellant tank to rupture causing a large explosion killing one and injuring 21, the silo and rocket were damaged beyond repair	Fire was imminent as a result of the quantity of fuel that had spilled	All workers should wear a belt with lanyards to attach tools, care should be taken to ensure the exclusive use of explosion proof hardware in a facility that contains hypergolic propellants, sending personnel into an unknown situation is extremely dangerous
KSC Incorrect Flight Cap N ₂ O ₄ Vapor Release	July 1981	KSC OPF1	A ¼-inch AHC cap was placed onto a ½-inch AHC causing the poppet to depress and the release N ₂ O ₄ (NO ₂) vapors, minor injuries, no hardware damage	¼" flight cap design is noticeably different than a ½" flight cap	An incorrect tag was attached to the flight cap and the number etched on the cap was sanded off in attempt to remove corrosion
MMH Exposure Following Flexhose Removal at Pad Farm	7/14/1981	KSC Pad 39A Fuel Farm	A technician removed a mislabeled flexhose resulting in an MMH spill, minor injuries, no hardware damage	None	Flexhose was not labeled as hazardous and procedure was not properly scrutinized
STS-2 OV-102 Right Pod MMH Fire	Fall 1981	KSC OPF1	Small amount of MMH dripped onto gold MLI blanket causing ignition, no injuries, minor flight hardware damage	Fire was possible as a result of spilled fuel	Ignition properties of MMH, incompatibility of MMH and gold
STS-2 OV-102 N ₂ O ₄ Spill	9/22/1981	KSC Pad 39A 207-Foot Level	Iron nitrates caused a QD to hang open, spilling approximately 15 to 20 gallons of N ₂ O ₄ , no injuries, notable flight hardware damage	None	Do not use QDs as shut off valves, inadequate spill protection

<u>Incident</u>	<u>Date</u>	<u>Location</u>	<u>Description</u>	<u>Advance Warning</u>	<u>Primary Lesson(s) Learned</u>
Pad 39A Fuel Farm MMH Spill and Fire Following Pneumatic Valve R&R	6/29/1982	KSC Pad 39A Fuel Farm	Valve removal led to MMH geyser hitting hot metal cable tray and igniting, no injuries, some GSE hardware damage	There was an indication on console in the LCC that several valves closed when the pneumatic control pressure was removed, fire was likely as a result of spilled fuel and local area containing iron oxide	Removal of GN ₂ control pressure allowed normally open valves to open, manual overrides added later
N ₂ O ₄ Vapor Release from Flange Gasket	2/10/1983	KSC Pad 39A Oxidizer Farm	A GSE valve gasket blew out, venting N ₂ O ₄ (NO ₂) vapors to atmosphere, there were no injuries or hardware damage	No warning other than loud noise moments before the vapor release	The technicians and engineers responded correctly
FRCS Ferry Plug Removal MMH Spill	4/18/1983	KSC OPF1	Cold outside temperatures caused thruster MMH valves to leak and collect liquid in the chambers, a technician was exposed to liquid (less than ½ cup) when a ferry plug was removed	Knowledge that thruster valves leak at cold temperatures	Keep thruster heaters on during all ferry flight and post-landing operations to prevent valve leakage
STS-9 OV-102 APU 1 and 2 Explosion	12/8/1983	EAFB Runway 170	Stress corrosion cracking was present in the APU injector stem thus causing an N ₂ H ₄ leak and explosion, no injuries, significant flight hardware damage	Valve module cooling noted at about 17 minutes after APU-1 and -2 were started for entry (an indication of N ₂ H ₄ evaporation/leakage, shutdown of APU 1 as a result of an “underspeed” condition	Injector stem is now chromized and manufacturing stresses are minimized
N ₂ O ₄ Vapor Release from Loose Fitting	2/17/1984	KSC OPF2	A small amount of N ₂ O ₄ vapor was released from an improperly torqued fitting on the GSE oxidizer vent system, no injuries or hardware damage	None	Inadequate contractor oversight resulted in many incorrectly torqued fittings in the vent system

<u>Incident</u>	<u>Date</u>	<u>Location</u>	<u>Description</u>	<u>Advance Warning</u>	<u>Primary Lesson(s) Learned</u>
CCAFS Tanker MMH Fire	5/16/1984	CCAFS Fuel Storage Area 1	MMH being drained from tanker low point sump ignited, technicians received minor burns through SCAPE suits, minor GSE hardware damage	Fire was possible as a result of spilled fuel	Was either result of electrostatic discharge from something nearby or reaction of MMH with local iron oxide (rust)
Liquid Trap in Purge Adapter Flexhose MMH Spill	5/24/1985	KSC OPF1	Approximately 1 cup of MMH spilled from a thruster purge adapter and onto the body flap, minor injuries, minor flight hardware damage	None	Proper procedure controls could have prevented this
STS-61C OV-102 SRB HPU Loading N ₂ H ₄ Spill	12/8/1985	KSC Pad 39A MLP Surface	During removal of Leer-Romec QD, AHC was spun off internal line leaking approximately 3 gallons of N ₂ H ₄ , no injuries or damage	Difference in mechanical motion during removal of QD	QD anti-rotation devices were implemented for use after RTF from Challenger
Inadvertent Dry Well Removal MMH Spill	1/21/1986	KSC Pad 39A Fuel Farm	A technician erroneously removed a temperature transducer dry well from a 3-inch GSE line causing a 12-foot geyser of MMH, spilling 100 gallons, minor injuries, minor GSE damage	Difference in mechanical motion during removal of transducer along with its dry well	Dry well retainers are now used on all hypergolic dry wells
Relief Valve R&R Oxidizer Farm N ₂ O ₄ Vapor Release	7/29/1986	KSC Pad 39A	During a relief valve R&R, a technician's SCAPE suit tore delaying an operation where the N ₂ O ₄ storage tank was open to atmosphere releasing N ₂ O ₄ (NO ₂) vapors, minor injuries, no hardware damage	Pressure indications on console showed a pressure differential of about 5 psig in the storage tank prior to the relief valve removal	Engineering had request to modify the hardware which was denied until after this incident, inadequate time was given prior to the valve removal to allow the propellant to cool
OPF2 Trench N ₂ H ₄ Spill and Fire	9/19/1986	KSC OPF2 Trench	N ₂ H ₄ leaked from a GSE check valve fitting that did not have an o-ring, dripped into trench, and reacted with the residual debris in the trench, igniting, no injuries or damage	Fire was possible as a result of spilled fuel	Care needs to be taken when installing components in hypergolic ground support equipment, also, cleanliness should be scrutinized

<u>Incident</u>	<u>Date</u>	<u>Location</u>	<u>Description</u>	<u>Advance Warning</u>	<u>Primary Lesson(s) Learned</u>
N ₂ O ₄ and Insulation Adhesive Small Fire	6/23/1988	KSC Pad 39B Oxidizer Farm	During a sampling operation, liquid N ₂ O ₄ spilled onto some GSE line insulation adhesive and ignited, no injuries, minimal hardware damage	None	An incompatibility exists between N ₂ O ₄ and the adhesive used, adhesive was not given enough time to properly cure
STS-26R OV-103 N ₂ O ₄ Tubing Leak on Vehicle	7/14/1988	KSC Pad 39B	A scratched LRCS N ₂ O ₄ propellant tank ullage vent dynatube leaked vapors into vehicle at a rate of about 0.23 psi/hour, no injuries or hardware damage	Discovery of leak came from remote data monitoring of propellant tank pressure in LCC	Probable cause was that the incorrect fitting was leak checked, the ingenuity of the launch team resulted in only a short delay in the launch of Discovery
WSTF Fuel Waste Flash Fire	2/16/1990	WSTF	Following the gravity draining of a fuel aspirator into a treatment tank, the residual vapors ignited, no injuries, minor hardware damage	None	Care needs to be taken in an environment that contains high concentrations of fuel vapors, they are highly susceptible to ignition
Aspiration of N ₂ O ₄ into Fuel Vent System	3/26/1990	WSTF TS 401	A fuel (MMH) aspiration flexhose was mistakenly connected to the N ₂ O ₄ GSE manifold service valve instead of the fuel manifold service valve, evidence of internal ignition, no injuries, minor hardware damage	None	Keying of the N ₂ O ₄ and MMH fittings was inadequate to preclude mismating, also the labeling and redundant labeling of the components was lacking
HMF Screens Test Drum MMH Spill	12/7/1990	KSC HMF M7-961 East Test Cell	The hard-line hose from a SCAPE suit caught on a GSE manual valve handle and opened it, filling a 55 gallon drum and subsequently spilling MMH out the drum's relief valve, no injuries or damage	None	It was not wise to design the system in which a manual valve handle protruded beyond the edge of the panel allowing items to become caught on it

<u>Incident</u>	<u>Date</u>	<u>Location</u>	<u>Description</u>	<u>Advance Warning</u>	<u>Primary Lesson(s) Learned</u>
STS-42 OV-103 Ferry Plug Removal MMH Spill	2/12/1992	KSC OPF3	Similar to the incident 4/18/1983, less than a cup of MMH spill from thruster when ferry plug was removed, no injuries or hardware damage	Knowledge that thruster valves leak at cold temperatures	Cold temperatures during a SCA stopover resulted in RCS thruster MMH valve to leak since vehicle remained unpowered and the thruster heaters were off
WSTF Incorrect Flight Cap N ₂ O ₄ Exposure	11/4/1992	WSTF OMS Ground Test Article	A ¼-inch AHC cap was placed onto a ½-inch AHC causing the poppet to depress and spill liquid N ₂ O ₄ , minor injuries, no hardware damage	¼" flight cap design is noticeably different than a ½" flight cap	Proper training of technicians would have decreased the possibility of this occurrence, similar to event on 7/14/1981
Thermochemical Test Area N ₂ O ₄ Vapor Release	4/21/1994	JSC TTA	Approximately 16 gallons of liquid N ₂ O ₄ vaporized and exited a burner stack as a result of a leaky solenoid valve and inadequately prepared test team, some minor injuries, no hardware damage	Initial small release of oxidizer vapors release through the burner stack, pressure drop in the oxidizer propellant tank from 800 psig to 600 psig	The test team failed to notice anomalous system performance and to take appropriate action
Titan IV A K-9 N ₂ O ₄ Spill	8/20/1994	CCAFS SLC-41	N ₂ O ₄ liquid release of approximately 350-400 gallons following thermal expansion causing a line to rupture at a weld seam while static shortly after sunrise	Local dial gauges likely showed the increase in pressure; however, there were not any technicians monitoring the gauges	Schedule pressure can result in leaving a system in an undesirable configuration, proper utilization of relief valves or ullage volumes should be mandatory
STS-69 OV-105 Left Pod MMH Fire	12/9/1994	KSC OPF1	Decomposition reaction of MMH in open thruster feedline caused ignition, no injuries or flight hardware damage	Pressure drop on console in the LCC indicated aspirator had been placed directly over thruster feedline, in-rush if air likely started decomposition reaction	Proper training needs to take place for all parties (including the engineers) relating to emergency response, hypergol fire identification, and communication

<u>Incident</u>	<u>Date</u>	<u>Location</u>	<u>Description</u>	<u>Advance Warning</u>	<u>Primary Lesson(s) Learned</u>
STS-69 OV-105 Right Pod MMH Fire	5/4/1995	KSC OPF1	MMH was present in a manifold that was having a dynatube disconnected, fire ignited possibly from an electrostatic discharge or decomposition reaction, no injuries, appreciable flight hardware damage	Transducer bias and shift change caused any advance warning to go unnoticed, but it did exist in the data	A transducer offset was not accounted for thus hiding an increase in the manifold pressure, proper care was not taken with respect to electrostatic discharge and fire extinguishing equipment
ORSU Open Manual Valve N ₂ O ₄ Spill	3/1/1996	WSTF 400-Area N ₂ O ₄ Storage Area	Liquid N ₂ O ₄ (approximately 90 gallons) poured from the vent stack of the storage tank, no injuries or hardware damage	None	Improper configuration management (manual valve left slightly open) existed in the 400-area vent system
OPF2 GSE MMH Spill	2/17/1997	KSC OPF2	Approximately a pint of MMH spilled from a line when the cap was removed, injuring three technicians, no hardware damage	When cap was initially disconnected a few drops of liquid were noted, technicians did not believe it was fuel and continued on	An unrecognized low point in the line allowed the MMH liquid to collect
HMF Sample Valve MMH Spill	3/26/1997	KSC HMF M7-1212 West Test Cell	Approximately ¾-cup of MMH spilled from a sample valve port, MMH collected in flexhose low point, minor injuries, no hardware damage	None	MMH was not saturated with helium which aids the draining procedure
VAFB Titan IV K-18 N ₂ O ₄ Spill	7/16/1997	VAFB SLC-4E	Three of four Titan IV SRM TVC FCVs failed during system pressurization spilling about 244 gallons of liquid N ₂ O ₄ onto the vehicle SRM aft skirts and ground, no injuries, minor flight hardware damage	None	Incompatible cleaning agents caused a seal in the FCV to rapidly expand within the valve when the Bio T-200A cleaning agent reacted with liquid N ₂ O ₄ , proper scrutiny of material compatibility was not completed on a newly design component

<u>Incident</u>	<u>Date</u>	<u>Location</u>	<u>Description</u>	<u>Advance Warning</u>	<u>Primary Lesson(s) Learned</u>
Pad 39B Slope N ₂ O ₄ Spill	11/6/1997	KSC Pad 39B Slope	An undersized flange gasket and improper mounting brackets enabled a water hammer effect to spill 25-50 gallons of liquid N ₂ O ₄ on the pad B slope, an electrical fire ensued when the liquid N ₂ O ₄ contacted some nearby live cabling, no injuries, minor GSE hardware damage	Discrepancy between the flange drawings for launch pads 39A and 39B, this type of advance warning was obscure and, therefore, not surprising that it went unnoticed	Improper configuration management by improper drawing specifications, drawings were not updated to require the installation of the proper gaskets as the pad A drawings were, cross-over valve complex was removed and replaced with hard-line tubing
STS-109 OV-102 APU N ₂ H ₄ Spill	8/20/1999	KSC OPF3	About 4.5 tbsp of liquid N ₂ H ₄ ran down a flexhose from the high point bleed QD and dripped on the orbiter elevon, no injuries, minimal flight hardware damage	Uncapped flexhose	New GSE was designed and installed to prevent this in the future
WSTF Pathfinder Axial Engine Valve Failure	8/7/2000	WSTF TS 401	During a decontamination procedure following an engine hotfire test, an axial engine valve and N ₂ O ₄ tubing failed (exploded) causing extensive damage to surrounding hardware, no injuries	NO ₂ vapor release at test cell drain valve, large cloud of NO ₂ vapor when engine valves were cycled	Working steps out of sequence and several days later than required along with performing the procedure with a temporary procedure rather than a permanent procedure were likely contributors to this event
WSTF Pathfinder Small MMH Fire	8/12/2000	WSTF TS 401	Small amount of MMH dripped from a disconnected feedline and ignited, minimal hardware damage and no injuries	Fire was possible as a result of spilled fuel	This event was likely the result of several issues compounding including ramifications from the incident that occurred on the same test article a few days prior
WSTF Pressure Transducer Explosion	3/25/2003	WSTF TC 831	A pressure transducer diaphragm failed causing N ₂ O ₄ to leak into a volume filled with silicon oil leading to an explosion and a vapor release of approximately 3 quarts, no injuries, some hardware damage	None	The pressure transducer manufacturer did not make the user aware that the transducer contained silicon oil

<u>Incident</u>	<u>Date</u>	<u>Location</u>	<u>Description</u>	<u>Advance Warning</u>	<u>Primary Lesson(s) Learned</u>
Titan IV N ₂ O ₄ Pump Explosion	8/12/2003	CCAFS LC-40	A clogged filter in the recirculation loop of the pump resulted in an increase in N ₂ O ₄ (NO ₂) vapors and a decrease in the lubrication of the stator allowing N ₂ O ₄ to breach the stator can and leak into the copper windings, causing an explosion, minor injuries, major GSE hardware damage	Decrease in oxidizer pump flow rate that was disregarded under the belief that it was a result of partially clogged filter	Improper maintenance of the pumps and possible design flaws led to the explosion
HMF RP01 N ₂ O ₄ Spill	6/5/2004	KSC HMF M7-961 East Test Cell	A flight cap was removed while, unknowingly, the AHC poppet was stuck slightly in the open state leaking roughly 1.4 gallons of N ₂ O ₄ , minor injuries and no hardware damage	Opaque Tygon hose and lack of time constraint on formation of bubbles covered up any advance indications, but it was likely present	The most probable causes include improper and/or inadequate bleed procedures, degradation of process and/or system knowledge over time, or nitrate buildup on the flight cap bleed port
WSTF N ₂ H ₄ Spill Following Manual Valve Failure	9/30/2005	WSTF TC 844B	A manual valve bonnet (handle) failed in a IAPU GSE setup spilling approximately 74 gallons of liquid N ₂ H ₄ into the test cell, no injuries, some GSE hardware damage	None	The valve soft seals failed thus leaking liquid N ₂ H ₄ into an internal area where an aluminum bronze fitting was located, over time the fitting corroded and later failed spilling the N ₂ H ₄
STS-121 FRC3 N ₂ O ₄ Spill	1/9/2006	KSC HMF M7-1212 West Test Cell	Approximately 2.9 gallons of N ₂ O ₄ spilled following removal of AHC MD122 poppet, no injuries, some flight hardware damage	None	Closer scrutiny of procedures and spill protection could have reduced the likelihood of this spill

51 Appendix C: Detailed Assessment of Incidents

The proceeding table is a summary of spill types, resulting injuries or hardware damage, root causes, and system configurations prior to the spill or fire that is referenced in this report along with the respective dates, spill quantities, and the location. An "R" denotes the root cause(s) of each particular incident. The proximate causes vary too much between incidents to include in this table.

Incident	Date	Quantity	Spilled Onto/Into	Commodity, Type, Injuries, and/or Damage													Root Cause			Occurred During					
				MMH	N ₂ H ₄	A-50	Fuel Fire	Fuel Explosion	Fuel Injuries	Fuel Hardware Damage	N ₂ O ₄ Liquid	N ₂ O ₄ (NO ₂) Vapor	N ₂ O ₄ Fire	N ₂ O ₄ Explosion	N ₂ O ₄ Injuries	N ₂ O ₄ Hardware Damage	No Damage or Injuries	Procedure Adherence/Control	Improper Personnel Training	Human Error (Operations)	Improper GSE/Vehicle Design	Improper Config. Management	During Commodity Movement	During R&R	During Hypergol Operation
Apollo 7 SPS N ₂ O ₄ Spill	Sept. 1968	~1 to 2 gal	Pad structure and vehicle								X				X				R					X	
Apollo-Soyuz Astronaut N ₂ O ₄ Vapor Exposure	7/24/1975	Vapors	Into crew compartment									X				R					X		X		
OV-101 APU 1 Cavity Seal N ₂ H ₄ Spill	6/28/1977	~5 gal	Into vehicle aft compartment	X						X								R		X		X			
Titan II Silo Large Scale N ₂ O ₄ Spill	8/24/1978	13,450 gal	Bottom of missile silo							X				X	X				R	X		X			
N ₂ H ₄ Spill Following APU Hotfire	Nov. 1979	~2 gal	OPF1 platforms	X											X			R				X			

<u>Incident</u>	<u>Date</u>	<u>Quantity</u>	<u>Spilled Onto/Into</u>	<u>Commodity, Type, Injuries, and/or Damage</u>													<u>Root Cause</u>			<u>Occurred During</u>						
				MMH	N ₂ H ₄	A-50	Fuel Fire	Fuel Explosion	Fuel Injuries	Fuel Hardware Damage	N ₂ O ₄ Liquid	N ₂ O ₄ (NO ₂) Vapor	N ₂ O ₄ Fire	N ₂ O ₄ Explosion	N ₂ O ₄ Injuries	N ₂ O ₄ Hardware Damage	No Damage or Injuries	Procedure Adherence/Control	Improper Personnel Training	Human Error (Operations)	Improper GSE/Vehicle Design	Improper Config. Management	During Commodity Movement	During R&R	During Hypergol Operation	During Opened System
Titan II Explosion Following A-50 Spill	9/18/1980	11,140 gal	Bottom of missile silo			X	X	X	X	X								R	R							X
KSC Incorrect Flight Cap N ₂ O ₄ Vapor Release	July 1981	Vapors	OPF1								X			X				R		R		X	X			
MMH Exposure Following Flexhose Removal at Pad Farm	7/14/1981	< ½ gal	Ground and technician	X					X								R		R	R	X	X	X			
STS-2 OV-102 Right Pod MMH Fire	Fall 1981	~1 tsp	Into vehicle pod	X			X			X								R	R				X	X		
STS-2 OV-102 N ₂ O ₄ Spill	9/22/1981	15 to 20 gal	Onto vehicle and pad structure								X				X			R	R		X		X			

Incident	Date	Quantity	Spilled Onto/Into	Commodity, Type, Injuries, and/or Damage													Root Cause			Occurred During						
				MMH	N ₂ H ₄	A-50	Fuel Fire	Fuel Explosion	Fuel Injuries	Fuel Hardware Damage	N ₂ O ₄ Liquid	N ₂ O ₄ (NO ₂) Vapor	N ₂ O ₄ Fire	N ₂ O ₄ Explosion	N ₂ O ₄ Injuries	N ₂ O ₄ Hardware Damage	No Damage or Injuries	Procedure Adherence/Control	Improper Personnel Training	Human Error (Operations)	Improper GSE/Vehicle Design	Improper Config. Management	During Commodity Movement	During R&R	During Hypergol Operation	During Opened System
Pad 39A Fuel Farm MMH Spill and Fire Following Pneumatic Valve R&R	6/29/1982	15 to 25 gal	Ground and into farm sump	X			X										R			R			X	X	X	
N ₂ O ₄ Vapor Release from Flange Gasket	2/10/1983	Vapors	Atmosphere										X				X			R					X	
FRCS Ferry Plug Removal MMH Spill	4/18/1983	¼ to ½ cup	OPF platform and technician	X															R				X	X		
STS-9 OV-102 APU 1 and 2 Explosion	12/8/1983	~1 gal	Into vehicle aft compartment		X			X												R		X		X		
N ₂ O ₄ Vapor Release from Loose Fitting	2/17/1984	Vapors	OPF2										X				X				R			X		
CCAFS Tanker MMH Fire	5/16/1984	< 2 gal	Ground and technician	X			X	X										R		R	X		X	X		

<u>Incident</u>	<u>Date</u>	<u>Quantity</u>	<u>Spilled Onto/Into</u>	<u>Commodity, Type, Injuries, and/or Damage</u>													<u>Root Cause</u>			<u>Occurred During</u>					
				MMH	N ₂ H ₄	A-50	Fuel Fire	Fuel Explosion	Fuel Injuries	Fuel Hardware Damage	N ₂ O ₄ Liquid	N ₂ O ₄ (NO ₂) Vapor	N ₂ O ₄ Fire	N ₂ O ₄ Explosion	N ₂ O ₄ Injuries	N ₂ O ₄ Hardware Damage	No Damage or Injuries	Procedure Adherence/Control	Improper Personnel Training	Human Error (Operations)	Improper GSE/Vehicle Design	Improper Config. Management	During Commodity Movement	During R&R	During Hypergol Operation
Liquid Trap in Purge Adapter Flexhose MMH Spill	5/24/1985	~1 cup	Onto vehicle	X							X						R				X	X	X		
STS-61C OV-102 SRB HPU Loading N ₂ H ₄ Spill	12/8/1985	~3 gal	Onto MLP surface		X										X			R		X		X			
Inadvertent Dry Well Removal MMH Spill	1/21/1986	~100 gal	Ground and farm sump	X				X	X								R		R		X	X			
Relief Valve R&R Oxidizer Farm N ₂ O ₄ Vapor Release	7/29/86	Vapors	Atmosphere								X			X				R	R		X	X	X		
OPF2 Trench N ₂ H ₄ Spill and Fire	9/19/1986	< ½ gal	OPF2 trench		X		X								X					R	X		X		

<u>Incident</u>	<u>Date</u>	<u>Quantity</u>	<u>Spilled Onto/Into</u>	<u>Commodity, Type, Injuries, and/or Damage</u>													<u>Root Cause</u>			<u>Occurred During</u>					
				MMH	N ₂ H ₄	A-50	Fuel Fire	Fuel Explosion	Fuel Injuries	Fuel Hardware Damage	N ₂ O ₄ Liquid	N ₂ O ₄ (NO ₂) Vapor	N ₂ O ₄ Fire	N ₂ O ₄ Explosion	N ₂ O ₄ Injuries	N ₂ O ₄ Hardware Damage	No Damage or Injuries	Procedure Adherence/Control	Improper Personnel Training	Human Error (Operations)	Improper GSE/Vehicle Design	Improper Config. Management	During Commodity Movement	During R&R	During Hypergol Operation
N ₂ O ₄ and Insulation Adhesive Small Fire	6/23/1988	~2 tbsp	Onto line insulation										X	X					R		X		X		
STS-26R OV-103 N ₂ O ₄ Tubing Leak on Vehicle	7/14/1988	Vapors	Into vehicle pod											X					R	R		X		X	
WSTF Fuel Waste Flash Fire	2/16/1990	None spilled	None	X			X												R		X			X	
Aspiration of N ₂ O ₄ into Fuel Vent System	3/26/1990	~2 tbsp	Into fuel vent system										X	X							R	X	X	X	
HMF Screens Test Drum MMH Spill	12/7/1990	~1 to 2 gal	Onto drum and HMF floor	X												X			R	R		X		X	
STS-42 OV-103 Ferry Plug Removal MMH Spill	2/12/1992	~¼ to ¾ cup	OPF3 platform and technician	X												X					R		X	X	

Incident	Date	Quantity	Spilled Onto/Into	Commodity, Type, Injuries, and/or Damage													Root Cause			Occurred During				
				MMH	N ₂ H ₄	A-50	Fuel Fire	Fuel Explosion	Fuel Injuries	Fuel Hardware Damage	N ₂ O ₄ Liquid	N ₂ O ₄ (NO ₂) Vapor	N ₂ O ₄ Fire	N ₂ O ₄ Explosion	N ₂ O ₄ Injuries	N ₂ O ₄ Hardware Damage	No Damage or Injuries	Procedure Adherence/Control	Improper Personnel Training	Human Error (Operations)	Improper GSE/Vehicle Design	Improper Config. Management	During Commodity Movement	During R&R
OPF2 GSE MMH Spill	2/17/1997	~1 pint	OPF2 platform and technicians	X					X									R			X	X	X	
HMF Sample Valve MMH Spill	3/26/1997	~¾ cup	HMF platform and technician	X					X									R				X	X	
VAFB Titan IV K-18 N ₂ O ₄ Spill	7/16/1997	~244 gal	Vehicle and ground								X			X				R				X		
Pad 39B Slope N ₂ O ₄ Spill	11/6/1997	25 to 50 gal	Ground and pad slope								X	X		X					R	X		X		
STS-109 OV-102 APU N ₂ H ₄ Spill	8/20/1999	< 5 tbsp	Onto vehicle elevon		X					X							R		R			X	X	
WSTF Pathfinder Axial Engine Valve Failure	8/7/2000	~1 to 2 gal	Into test cell								X		X	X		R				X		X		
WSTF Pathfinder Small MMH Fire	8/12/2000	~1 cup	Nearby hardware and technician	X			X											R				X	X	

Incident	Date	Quantity	Spilled Onto/Into	Commodity, Type, Injuries, and/or Damage													Root Cause			Occurred During						
				MMH	N ₂ H ₄	A-50	Fuel Fire	Fuel Explosion	Fuel Injuries	Fuel Hardware Damage	N ₂ O ₄ Liquid	N ₂ O ₄ (NO ₂) Vapor	N ₂ O ₄ Fire	N ₂ O ₄ Explosion	N ₂ O ₄ Injuries	N ₂ O ₄ Hardware Damage	No Damage or Injuries	Procedure Adherence/Control	Improper Personnel Training	Human Error (Operations)	Improper GSE/Vehicle Design	Improper Config. Management	During Commodity Movement	During R&R	During Hypergol Operation	During Opened System
WSTF Pressure Transducer Explosion	3/25/2003	~3 quarts	Test cell table								X			X	X				R		X		X			
Titan IV N ₂ O ₄ Pump Explosion	8/12/2003	~40 gal	Ground								X		X	X	X			R	R	X		X				
HMF RP01 N ₂ O ₄ Spill	6/5/2004	~1.4 gal	HMF platform and technician								X			X		R	R				X	X				
WSTF N ₂ H ₄ Spill Following Manual Valve Failure	9/30/2005	~74 gal	Into cell and containment tank	X						X								R	R						X	
STS-121 FRC3 N ₂ O ₄ Spill	1/9/2006	~2.9 gal	HMF platform								X			X				R			X	X	X			
45 Total Incidents Reported				Total	24	8	2	7	12	16	7	3	3	8	12	10	7	11	17	24	11	18	15	41	13	3

