

PLATFORM PRECISION AUTOPILOT OVERVIEW AND MISSION PERFORMANCE

Brian K. Strovers and James A. Lee, Aerospace Engineers
NASA Dryden Flight Research Center, P.O. Box 273, Edwards, CA, 93523-0273
Brian.K.Strovers@nasa.gov and James.A.Lee-1@nasa.gov

The Platform Precision Autopilot is an instrument landing system–interfaced autopilot system, developed to enable an aircraft to repeatedly fly nearly the same trajectory hours, days, or weeks later. The Platform Precision Autopilot uses a novel design to interface with a NASA Gulfstream III jet by imitating the output of an instrument landing system approach. This technique minimizes, as much as possible, modifications to the baseline Gulfstream III jet and retains the safety features of the aircraft autopilot. The Platform Precision Autopilot requirement is to fly within a 5-m (16.4-ft) radius tube for distances to 200 km (108 nmi) in the presence of light turbulence for at least 90 percent of the time. This capability allows precise repeat-pass interferometry for the Unmanned Aerial Vehicle Synthetic Aperture Radar program, whose primary objective is to develop a miniaturized, polarimetric, L-band synthetic aperture radar. Precise navigation is achieved using an accurate differential global positioning system developed by the Jet Propulsion Laboratory. Flight-testing has demonstrated the ability of the Platform Precision Autopilot to control the aircraft within the specified tolerance greater than 90 percent of the time in the presence of aircraft system noise and nonlinearities, constant pilot throttle adjustments, and light turbulence.

Introduction

Within the Earth science community, there is a growing need and desire for accurate Earth deformation measurements, which assist in the study and understanding of dynamically changing geological features resulting from earthquakes, volcanoes, and ice cap changes (Donnellan et al., 2004; Zebker et al., 1994). A synthetic aperture radar (SAR) provides this capability through a combination of active remote sensing, high-resolution mapping, and repeat passes over the area of interest. The SAR systems use a moving platform to create a narrow effective beam of electromagnetic waves that traverse a desired ground track. Complex post processing of this data provides a detailed image of the terrain. The phase data from two observation passes of the same terrain are compared by applying a technique known as interferometric SAR; any phase difference indicates terrain movement (Rosen et al., 2000; van Zyl, 1997).

Because of the time varying nature of rapidly deforming features, scientists require observational sampling intervals of a day or less to capture and model these events (Wheeler et al. 2003). Most SAR systems are currently implemented on satellites, which have much longer repeat orbit cycles, on the order of weeks or even months. This aspect limits the effectiveness of these assets in the study of quickly deforming features. In its latest configuration, the NASA Airborne Synthetic Aperture Radar (AIRSAR) (Lou and van Zyl, 1996; Lou et al., 2001) system was able to demonstrate quick repeat observations when integrated on the NASA DC-8 (McDonnell Douglas, now The Boeing Company, Chicago, Illinois) Airborne Laboratory. The AIRSAR lacked track repeatability, however, which is an important factor for interferometry to work correctly. The resolution and accuracy of the DC-8 navigation architecture were insufficient to perform precision trajectory and repeat-pass interferometry (RPI). When implemented on any airborne platform, RPI is difficult for three main reasons. 1) Turbulence, wind gusts, and other varying atmospheric conditions make it difficult to fly the same path at different times. 2) A high precision navigation capability is required. 3) Varying crosswinds makes it difficult to maintain the same antenna azimuth or heading on repeated passes (Hensley et al., 2007).

In the 1990s, the Danish Center for Remote Sensing (DCRS, Lyngby, Denmark) conducted a project to attempt to resolve these complications with airborne RPI. Using a Danish Air Force Gulfstream III jet (G-III, Gulfstream Aerospace Corporation, A General Dynamics Company, Savannah, Georgia), the DCRS was able to demonstrate precision autopilot operation (Madsen et al., 1996). Modeled after this DCRS project, the NASA Unmanned Aerial Vehicle Synthetic Aperture Radar (UAVSAR) program, the successor to AIRSAR, has used similar methods to

overcome these challenges as well. The UAVSAR system has the capability to conduct radar RPI measurements with observational sampling intervals or periods ranging from minutes to years, allowing surface measurements of centimeter level accuracy.

The UAVSAR program is supported by the NASA Dryden Flight Research Center (DFRC, Edwards, California) and led by the Jet Propulsion Laboratory (JPL, Pasadena, California). The primary objective of the UAVSAR program is to develop a miniaturized, polarimetric, L-band SAR for use on an unmanned aerial vehicle (UAV) or minimally piloted vehicle. A G-III (NASA 502), as shown in Fig. 1, was chosen and modified with a pylon to carry external stores. External stores carried on the pylon attach using a MAU-12 interface with a maximum of 1200 lbs, 30 inch diameter, and 10 ft length. Conditioned 28 volts at maximum 70 amps is provided to external stores. For real-time evaluation and in-flight adjustments to sensors 8 seats are provided for experimenters. The aircraft is capable of loiter times up to 8 hours, has a range up to 4,000 nmi at typical cruise altitudes of 25,000 to 45,000 feet, and speeds in the 300 – 500 knot range. The aircraft is equipped with a data recording system for aircraft states and extra channels for onboard experiments. The eventual goal of the project is to transition the SAR pod onto a UAV platform.



Figure 1. NASA Gulfstream III jet carrying miniaturized polarimetric L-band synthetic aperture radar.

The DFRC played a crucial role in the project as the developer of the Platform Precision Autopilot (PPA), an enabling technology that allows the UAVSAR to perform precise repeat-pass interferometry. This report describes some architecture and mission performance of the PPA.

Platform Precision Autopilot

An essential element for the success of the UAVSAR program is the PPA. The PPA interfaces with the G-III by imitating the output of instrument landing system (ILS) antennas. This technique has several advantages; system modifications to the baseline G-III are minimized by interfacing with one of the aircraft's navigation receivers, and the built-in safety features of the G-III systems and autopilot are retained. Examples of the applicable safety features are the aircraft autopilot rate and saturation limits on the localizer (lateral guidance) and glide slope (vertical guidance) to prevent any excessive maneuvers. The PPA generates commands that drive two ILS interface system (I2S) units, which are two modified ILS testers, to produce modulated radio frequency (RF) signals. These RF signals are fed to the aircraft navigation receiver, which then directs the G-III autopilot to fly a constant-altitude ILS approach to meet the PPA requirements for the UAVSAR. The primary PPA objective is to make repeat-pass flights within a 5-m (16.4-ft) radius tube over a 200-km (108-nmi) course in conditions of calm to light turbulence (U.S. DoD, 1990) for 90 percent of the time.

Hardware

The PPA is composed of three major hardware elements: the autopilot interface computer (AIC), I2S, and the PPA operator station. Figure 2 shows the PPA system architecture and the interfaces between these major hardware components and the G-III aircraft systems, which include the navigation receiver, flight director, and baseline autopilot. The AIC and I2S units, along with a power distribution panel, are designed to fit on a single pallet, which interfaces to the standard G-III cabin experimenter's rack. A second PPA pallet was added to the rack for redundancy during remote missions. With the addition of JPL's differential global positioning system (dGPS) and a data acquisition research instrumentation system called the data collection and processing system (DCAPS), the PPA has all the necessary hardware to command the G-III autopilot.

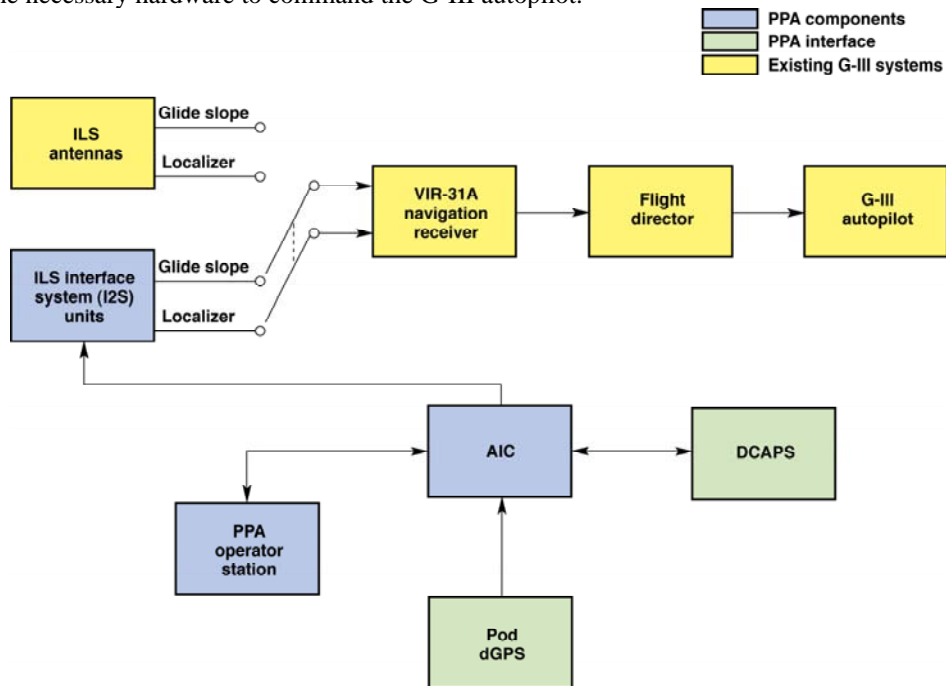

Figure 2. Platform Precision Autopilot system architecture.

Autopilot Interface Computer

The AIC hosts the PPA software routines, which consist of C auto-code. This miniature computer is housed in a 6- by 3.5- by 1.6-in. enclosure and has a total weight of less than 2 lb. The processor consists of a Phytex MPC565-based microcontroller (Phytex America, LLC, Bainbridge Island, Washington) mounted on a single board computer module operating at 56 MHz. Also included in the AIC are all the necessary power and signal conditioning elements. Figure 3 shows the PPA software architecture and external interfaces. The AIC provides a controller area network (CAN) interface with the operator station, RS-422 interface with the dGPS, and EtherNet® (Xerox Corporation, Palo Alto, California) interface with the DCAPS. Additionally, the AIC generates analog commands using a digital-to-analog converter (DAC) interface and transmits them to the two I2S units.

Instrument Landing System Interface

An I2S unit consists of a modified ILS ramp tester, which is capable of generating localizer or glide slope RF test signals needed to drive the G-III navigation receiver. The two I2S units receive analog voltage commands from the AIC. To independently modulate glide slope and localizer signals, two units are required. One I2S is

commanded with a glide slope input and set for glide slope RF output, and the other is commanded with a localizer input and set for localizer RF output.

Operator Station

The operator station, which runs LabWindows™/CVI (C-Language Virtual Instrument, National Instruments Corporation, Austin, Texas), is the graphical user interface to the PPA. Using a CAN data bus, the operator station communicates with the AIC to monitor its status and serve the following functions: selects altitude and course path type, initializes navigation software routine, allows zeroing of biases, initiates built-in tests, engages and disengages PPA, uploads waypoint file for trajectory generation, displays and records data for postflight analysis, and displays status information, including data validity.

Data Collection and Processing System

The DCAPS is the principle instrumentation system on the G-III. Developed at DFRC, DCAPS is largely a passive system that collects and archives aircraft state and instrumentation data through the G-III ARINC-429 bus, and distributes and displays it real time (Hang, 2007). Using a 40-Hz user data protocol (UDP) link through the EtherNet® interface operating at 10 Mb/s, the DCAPS provides navigation data to the AIC.

Differential Global Positioning System

The dGPS unit, designed by JPL, provides Earth centered, Earth fixed (ECEF) position in meters. It achieves high accuracy by using two sources of GPS correction communicated through Inmarsat (Inmarsat, plc, London, England) and Iridium (Iridium Satellite, LLC, Bethesda, Maryland) satellite systems, and two differential GPS units. Four position solutions are computed, and the best solution is automatically selected and output at 1 Hz. The dGPS 1-σ position accuracy is advertised at 10 cm horizontally and 20 cm vertically.

Software

The PPA software runs at 40 Hz and is composed of MATLAB® functions and Simulink® block diagrams auto-coded into C code using the Real-Time Workshop® embedded coder (MATLAB®, Simulink®, and Real-Time Workshop® are registered trademarks of The MathWorks™, Inc., Natick, Massachusetts). The architecture of the software (Fig. 3) is broken down into three main subsystems: navigation, guidance, and controller.

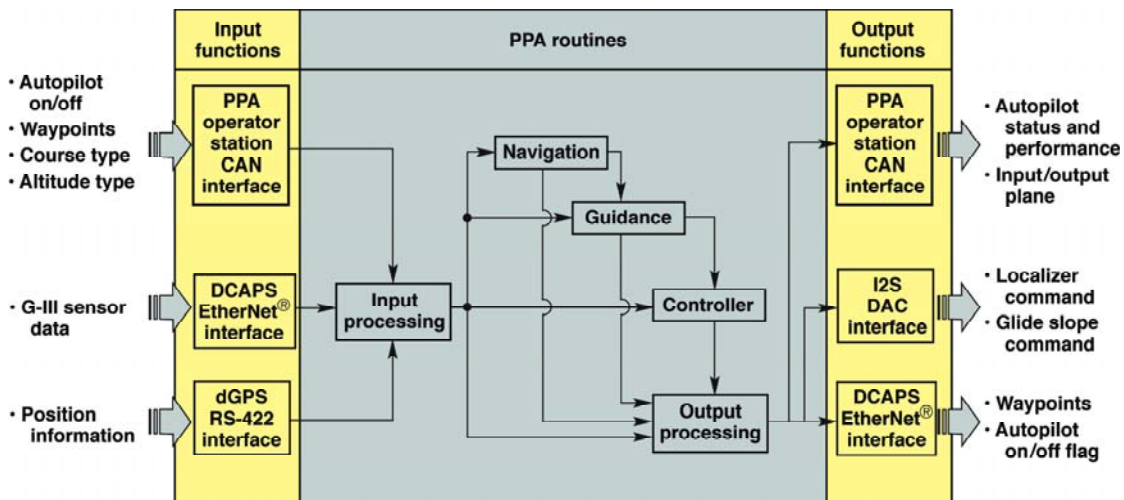

Figure 3. Platform Precision Autopilot software architecture and external interfaces.

Navigation Routine

The navigation routine centers around a MATLAB® m-file designed to be called as an embedded function in Simulink®. The navigation filter generates an accurate position estimate using 1-Hz lagged position measurements from the dGPS and 16-Hz velocity data from the aircraft inertial navigation system (INS). A Kalman filter is implemented in the ECEF frame as a tracking filter with 12 states: position, velocity, velocity-bias, and acceleration state for each of the 3 axes. Velocity measurements from the INS and dGPS position measurements are used as observations. By comparing the INS velocity to the velocity obtained by numerically differentiating the dGPS position inputs, the velocity bias state is created. The acceleration state is driven by white noise. The final observation vector has 9 elements; each of the 3 axes has a dGPS-derived position estimate, an INS-derived velocity, and an estimate of the bias between the INS-derived velocity and the dGPS derived velocity (Grewal and Andrews, 2001). The ECEF coordinates were chosen for the positions and velocities to allow the state update for the three axes to be decoupled. The state and observation vectors were chosen so that each observation directly corresponds to one of the states, simplifying the filter update. The corrected position is used directly as the true position measurement with no bias term built into the state vector. In the end, the position outputs are converted from the ECEF coordinate frame to latitude, longitude, and altitude for use by the guidance routine.

Guidance Routine

The guidance routine consists of Simulink® block diagrams and embedded MATLAB® code. The main function in the guidance routine computes the intermediate waypoints that define the course line. The latitude and longitude for the start and end waypoints and the course type are required inputs for this routine. The course type can be selected as a constant heading (loxodromic) or great circle and shortest distance (geodetic). Both course types are computed using the World Geodetic System 1984 (WGS 84) geodetic Earth model (NIMA, 1984). The loxodromic code is based on heritage FORTRAN code provided by JPL, and the great circle code uses an iterative Bessel solution (Borre, 1997).

Controller Routine

The PPA control consists of two proportional-integral-derivative controllers, one for the localizer axis and the other for the glide slope axis. Within the localizer controller, the localizer proportional loop applies a gain to the crosstrack error and limits the output to reduce the maximum course intercept angle. The overshoot of the specified trajectory is kept smaller by limiting the course intercept angle. The localizer derivative loop is driven by the track (heading) error calculated in the guidance routine. To improve damping during course intercept, a lead filter is applied to the track (heading) error signal. The glide slope controller is similar to the localizer channel and is driven by the altitude error, which has been passed through a lead filter. The glide slope derivative loop is driven by the aircraft inertial vertical velocity and is faded in over 5 s to reduce the load factor when the PPA is engaged. For increased damping, pitch rate feedback, which is provided by the aircraft systems, is also used.

Flight Test Results

Figure 4 shows final flight test results over plotted with the GIII cruise envelope. The circles at each flight condition represent the 5-m radius tube. The outer margin of the embedded contour plot encompasses 90 percent of the flight track time for that flight condition. Most course legs shown in figure 4 were flown on 120 nmi legs for approximately 15 to 20 minutes. The course at mach 0.75 and 39,000 feet was much shorter showing mostly the intercept with the course rather than tracking data. All the data with brief variations in altitude were caused by throttle inputs during tracking. Generally, there was adequate performance to keep the G-III inside (or within a meter) of the tube boundary more than 90 percent of the time for each flight segment. The flights were conducted on a number of days with considerable variation in atmospheric stability, lifting action, turbulence, and temperature. The flights were generally on the eastern (leeward) side of the Sierra Nevada Mountain range in a north-south direction, a region known for frequently unstable air. The variation in G-III performance under PPA control can, in part, be attributed to these factors.

Mission Performance

The UAVSAR program has conducted several science missions over Mount St. Helens, the Salton Sea, Death Valley, and The California coast from San Francisco to San Diego using the PPA. For most of these flights, the PPA performs better than the 5-m radius tube requirement. For 342 SAR data runs spread over 20 flights, the PPA has controlled the G-III within ± 2.5 -m in altitude and crosstrack more than 90 percent of the time exceeding the expectations in the requirement (Fig. 5). The UAVSAR missions started low and slow during initial SAR checkout flights. After refining SAR performance mission speeds and altitudes increased. Missions are currently being flown at the higher altitudes (between 39,000 and 43,000 ft) in the middle to low end of the speed (Mach 0.67 to 0.82) envelope (Fig. 4).

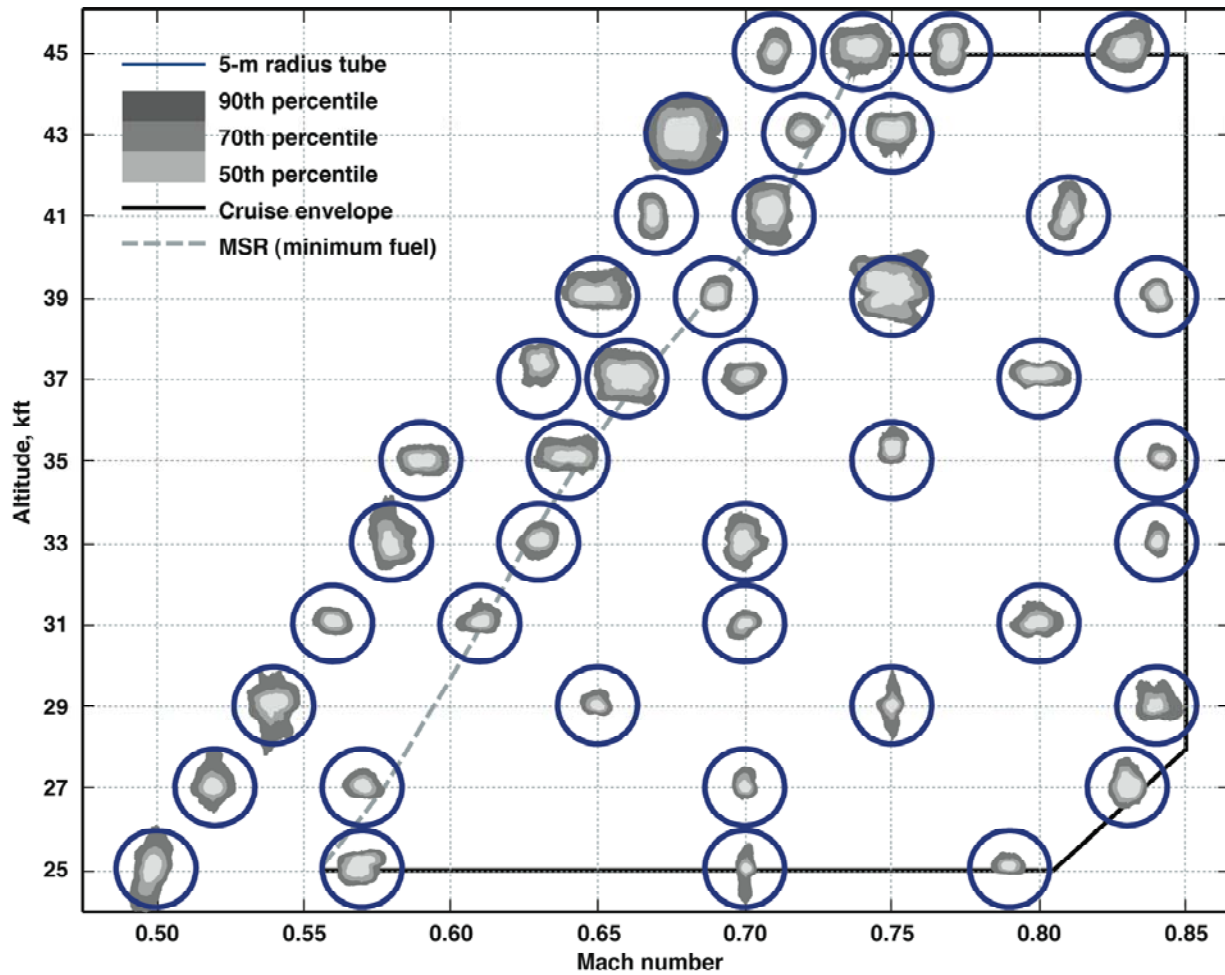

Figure 4. PPA flight envelope with outer contours encompassing 90 percent of flight time at each flight condition.

Conclusion

A Platform Precision Autopilot (PPA) developed to support the NASA Unmanned Aerial Vehicle Synthetic Aperture Radar (UAVSAR) program. The PPA has demonstrated a history meeting the requirement of flying within a 5-m (16.4-ft) radius tube for distances to 200-km (108-nmi) long in the presence of light turbulence for 90 percent of the time. This capability allows precise, repeat-pass interferometry for the UAVSAR program, whose primary objective is to develop a miniaturized, polarimetric, L-band synthetic aperture radar for repeat-pass interferometry. The PPA has demonstrated the ability to control an aerial platform very precisely while minimizing unwanted motion. The PPA system has been successfully used in the field for science missions since December 2007. The customer, Jet Propulsion Laboratory, has noted that the PPA performance most often performs better than the requirements.

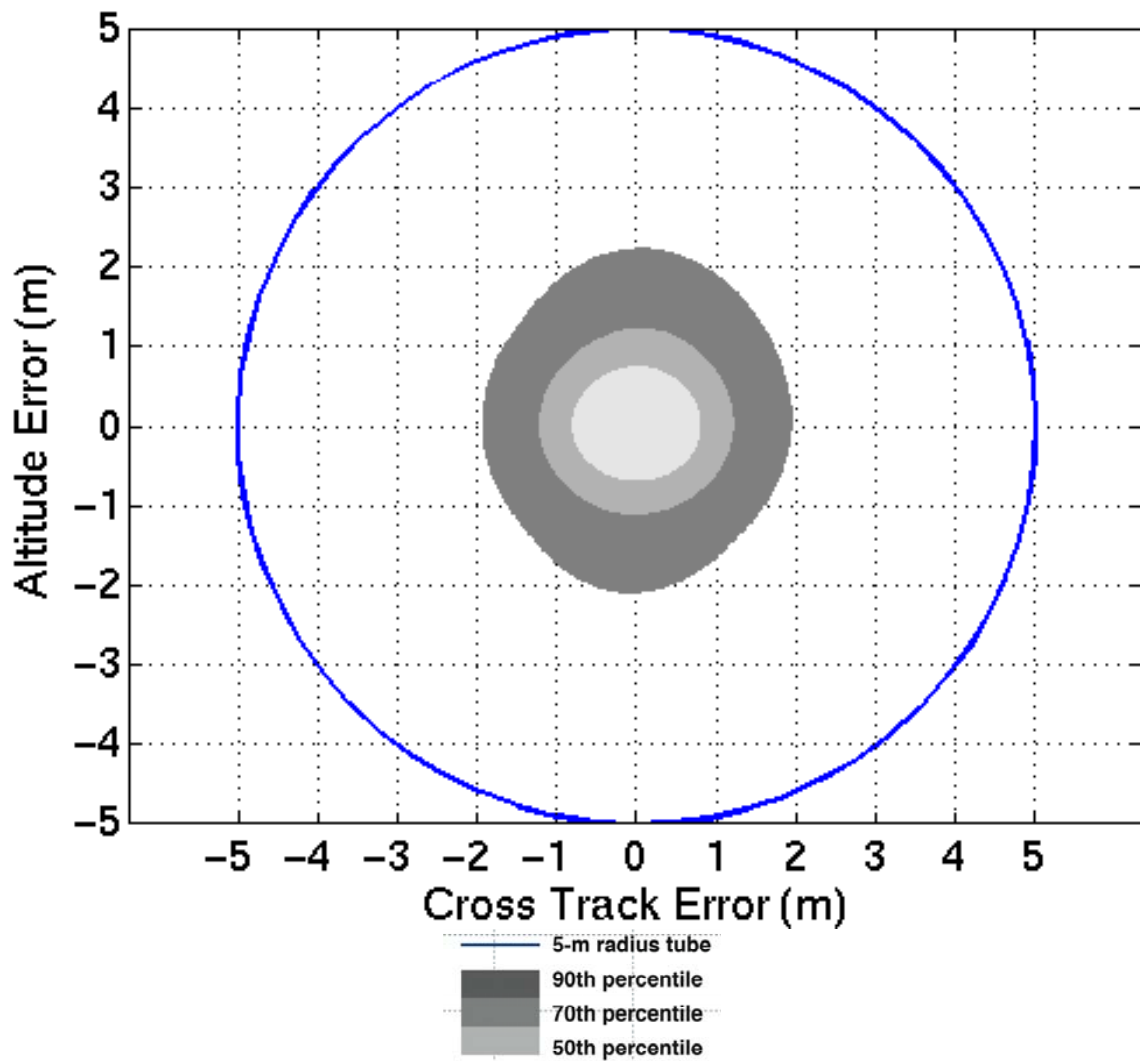

Figure 5. Platform Precision Autopilot performed better than the 5-m radius tube objective for all of JPL's science mission flights; 342 data runs spread over 20 flights and 48.4 hours of total tracking time.

References

- Borre, K., 1997, *Linear Algebra, Geodesy, and GPS*, Wellesley-Cambridge Press, Wellesley, MA.
- Donnellan, A., Fielding, E., Glasscoe, M., Holt, B., Kwok, R. et al., 2004, InSAR Workshop Summary Report, InSAR Workshop, JPL 400-1240, NASA.
- Grewal, M., and Andrews, A., 2001, *Kalman Filtering: Theory and Practice Using MATLAB®*, 2nd Edition, John Wiley & Sons, Inc., New York, Chapter 4.
- Hang, R., 2007, Data Collection And Processing System (DCAPS): System Design Objectives Documents, NASA G3-DCAP-SDO-001.
- Hensley, S., Wheeler, K., Sadowy, G., Jones, C., Shaffer, S., Zebker, H. et al, 2007, "The UAVSAR Instrument: Description and Test Plans," 2007 NASA Science and Technology Conference, NASA.
- Lou, Y., Kim, Y., and van Zyl, J., 1996, "The NASA Airborne Synthetic Aperture Radar System," Conference at the Jet Propulsion Laboratory, JPL TRS 1992+ 96-0290.
- Lou, Y., Imel, D.A., Chu, A., Miller, T.W., Moller, D., and Skotnicki, W., 2001, "Progress Report on the NASA/JPL Airborne Synthetic Aperture Radar System," 2001 *IEEE International Geoscience and Remote Sensing Symposium*, Vol. 5, IEEE, New York, pp. 2046-2048.
- Madsen, S.N., Skou, N., Granholm, J., Woelders, K.W., and Christensen, E.L., 1996, "A System for Airborne SAR Interferometry," *AEU International Journal of Electronics and Communications*, Vol. 50, No. 2, pp. 106-111.
- National Imagery and Mapping Agency, 2000, "Department of Defense World Geodetic System 1984," NIMA TR8350.2, 3rd Ed., Amendment 1.
- Rosen, P.A., Hensley, S., Joughin, I.R., Li, F.K., Madsen, S.N., Rodriguez, E., and Goldstein, R.M., 2000, "Synthetic Aperture Radar Interferometry," *Proceedings of the IEEE*, Vol. 88, No. 3, IEEE, New York, pp. 333-382.
- van Zyl, J.J., 1997, "Overview of SAR Polarimetry and Interferometry," *Proceedings of the SPIE*, Vol. 3120, JPL TRS 1992+ 97-1538, pp. 16-27.
- Wheeler, K., Hensley, S., Lou, Y., Miller, T., and Hoffman, J., 2003, "An L-Band SAR for Repeat Pass Deformation Measurements on a UAV Platform," 2nd AIAA "Unmanned Unlimited" Systems, Technologies, and Operations, AIAA 2003-6619.
- U.S. Department of Defense, 1990, "Flying Qualities of Piloted Aircraft," MIL-STD-1797A, Appendix A. (Contact: ASD/ENES, Wright-Patterson AFB, OH 45433-6503.)
- Zebker, H.A., Farr, T.G., Salazar, R.P., and Dixon, T.H., 1994, "Mapping the World's Topography Using Radar Interferometry: the TOPSAT Mission," *Proceedings of the IEEE*, Vol. 82, No. 12, IEEE, New York, pp. 1774-1786.