

## Comment on Modified Stokes Parameters

D.M. Le Vine and C. Utku  
Goddard Space Flight Center, Greenbelt, MD 20772

**Abstract:** It is common practice in passive microwave remote sensing (microwave radiometry) to express observables as temperatures and in the case of polarimetric radiometry to use what are called “Modified Stokes Parameters in Brightness Temperature” to describe the scene. However, definitions with slightly different normalization (with and without division by bandwidth) have appeared in the literature. The purpose of this manuscript is to present an analysis to clarify the meaning of terms in the definition and resolve the question of the proper normalization.

### I. Introduction

It is common practice in passive microwave remote sensing (microwave radiometry) to express observables as temperatures, a practice apparently inherited from radio astronomy [1a, 2a]. In the case of polarimetric radiometry it is common to use the notation of Stokes parameters but with the correlations normalized to units of temperature (e.g. [3]). The terminology has recently been clarified in the “Standard Terminology for Microwave Radiometry”, a monograph of definitions prepared by the radiometry community, where the normalized correlations are called “Modified Stokes Parameters in Brightness Temperature” [4, 5]. The definition in Chapter III of this monograph is:

$$T_v = [\lambda^2/\eta k B_w] \langle |E_v|^2 \rangle \quad (1a)$$

$$T_h = [\lambda^2/\eta k B_w] \langle |E_h|^2 \rangle \quad (1b)$$

$$T_3 = [\lambda^2/\eta k B_w] 2 \operatorname{Re} \langle E_v E_h^* \rangle \quad (1c)$$

$$T_4 = [\lambda^2/\eta k B_w] 2 \operatorname{Im} \langle E_v E_h^* \rangle \quad (1d)$$

where  $\lambda$  is the wavelength,  $k$  is the Boltzmann’s constant,  $B_w$  is bandwidth and  $\eta$  is the wave impedance of the medium. As will be pointed out below, there is ambiguity with

the meaning of expressions such as  $\langle |E_v|^2 \rangle$ . There also appears to be disagreement regarding the form of Equations 1 and versions have appeared in the literature with and without the presence of bandwidth,  $B_w$ , on the right hand side [6, 7, 8]. The purpose of this manuscript is to present an analysis, in the context of radiometry, to clarify the meaning of the quantities on the right-hand side of Equations 1. Our goal is to resolve the question of the proper normalization in these expressions and to add insight into the definitions presented in the “Standard Terminology for Microwave Radiometry” [4].

One approach for obtaining Equations 1 is to model the radiometer response along the lines of classical radio astronomy (i.e. in terms of the incident brightness) and then use arguments from electromagnetic theory to relate the brightness to the electromagnetic fields. This two-step approach is outlined in Appendices A and B, respectively. A slightly different approach is adopted here in an effort to relate the results more directly to polarimetric measurements as used in contemporary microwave remote sensing radiometry. The analysis begins in Section II with the output of an idealized correlation radiometer. Section III rewrites the output as equivalent temperature and Section IV puts the results in the form of Equations 1. An interpretation in terms of familiar results is given in Section V. We conclude that when  $\langle |E_p|^2 \rangle / \eta$  is equivalent to the source brightness at polarization “p”, then the bandwidth,  $B_w$ , should not appear in Equations 1.

## II. Radiometer Response

Consider the idealized “correlation” radiometer shown in Figure 1. It consists of two paths whose signals are multiplied together and averaged. The multiplication is “coherent” (i.e. phase and amplitude are measured). For the purpose of this investigation, the details of the implementation with real hardware (e.g. [9]) is omitted and all the operations are assumed ideal: The antenna is lossless and its output voltage,  $e_p(t)$ , is the input to an ideal receiver (no noise, no cross-coupling, ideal operations). In this idealized case,  $h_p(t)$  denotes the effective impulse response of the arm with polarization,  $p = \{p, q\}$ , and the last step after the multiplication (operationally a low pass filter) is assumed to be sufficiently narrowband to be represented by an integral. An idealized receiver is

appropriate here because the goal is to determine the form which the input takes after processing rather than the limits that real hardware place on estimating this quantity.

A correlation receiver has been taken as the starting point to be general and also to explicitly include the processing involved in polarimetric radiometry. A total power radiometer is a special case when the two paths are identical. In the more general case, the system represents a single antenna with two different polarization ports (e.g.  $p = h$  and  $q = v$ ) as is appropriate for polarimetric radiometry. In principle, the schematic could also represent measurements with two different antennas as would be the case, for example, in an interferometer or synthetic aperture radiometer [10]. The analysis in this case follows as outlined below, but one must explicitly include the relative distance (spacing) between the antennas [11]. Including this term and realistic constraints [11,12] complicates the analysis and since it is not pertinent to the issue at hand, this case is not included here

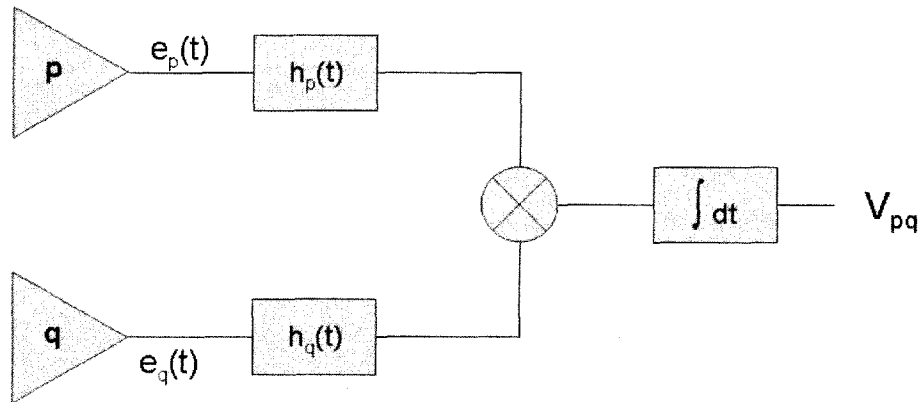

Fig. 1: Receiver architecture. The output signal,  $e_p(t)$ , from each antenna is the input to an ideal correlating radiometer receiver. The antenna is described by its complex voltage patterns and the receiver path is described by its impulse response,  $h_p(t)$ .

The output of the receiver in Figure 1 can be written:

$$V_{pq}(t) = (1/2T) \int_{-T}^T [e_p(t-t') * h_p(t-t')] [e_q(t-t') * h_q(t-t')] dt' \quad (2)$$

Equation 2 is the result of three operations: a) The response of each arm (p,q) of the receiver which is given by the convolution  $e(t)*h(t)$ ; b) the product of the signal out of each arm which is the product of the two convolution pairs (i.e. the terms in square brackets); and c) the time average of the product. The last step is represented by the integral over the parameter  $t'$ . The parameter,  $\mathcal{T}$ , represents the equivalent time constant of the last stage of the receiver in Figure 1 and the integration is over a window of width  $2\mathcal{T}$  centered at  $t$ . In Equation 2, the asterisk “\*” indicates a convolution but in all the work to follow it will indicate the complex conjugate. Replacing the terms in the integrand of Equation 2 with their Fourier transform and using the fact that they are real quantities, one obtains:

$$V_{pq}(t) = (1/2\mathcal{T}) \int_{-T}^T \int_{-T}^T dv \int_{-T}^T dv' E_p(v)E_q^*(v') H_p(v)H_q^*(v') \exp[-j2\pi(v-v')(t-t')] dt' \quad (3)$$

$E_p(v)$  and  $H_p(v)$  denote the Fourier transform of the time domain functions,  $e_p(t)$  and  $h_p(t)$ , respectively. (See Appendix B for a definition of the Fourier transform pair.) Following convention,  $E_p(v)$ , can be written in terms of the incident electric fields,  $\mathcal{E}_p(\Omega, v)$ , and the complex “voltage” patterns,  $\mathcal{A}_p(\Omega, v)$ , of the antennas [13]:

$$E_p(v) = \sqrt{A_p} \int_{4\pi} \mathcal{E}_p(\Omega, v) \mathcal{A}_p(\Omega, v) d\Omega \quad (4)$$

where  $A_p$  is the effective area of the antenna [1b, 2b] and  $\Omega$  is solid angle:  $\Omega = \{\theta, \phi\}$  and  $d\Omega = \sin(\theta)d\theta d\phi$ . Substituting Equation 4 into Equation 3, one obtains:

$$V_{pq}(t) = (1/2\mathcal{T}) \int_{-T}^T \left\{ \int \int \sqrt{(A_p A_q)} \int \int \mathcal{E}_p(\Omega, v) \mathcal{E}_q^*(\Omega', v') \mathcal{A}_p(\Omega, v) \mathcal{A}_q^*(\Omega', v') \dots \dots H_p(v)H_q^*(v') \exp[-j2\pi(v-v')(t-t')] d\Omega d\Omega' dv dv' \right\} dt' \quad (5)$$

Since the application is to remote sensing of natural sources, the incident field will be modeled as a random process. Consequently, the radiometer output will also be a random process. The goal is to compute the expected value of the radiometer output,  $\langle V_{pq}(t) \rangle$ :

$$\begin{aligned} \langle V_{pq}(t) \rangle = & \int_{-T}^T \left\{ \int \int \sqrt{(A_p A_q)} \int \int \langle \mathcal{E}_p(\Omega, \nu) \mathcal{E}_q^*(\Omega', \nu') \rangle \mathcal{A}_p(\Omega, \nu) \mathcal{A}_q^*(\Omega', \nu') \dots \right. \\ & \left. \dots H_p(\nu) H_q^*(\nu') \exp[-j2\pi(\nu - \nu')(t - t')] d\Omega d\Omega' d\nu d\nu' \right\} dt' \end{aligned} \quad (6)$$

To simplify the analysis, it is assumed that the process is stationary and that the fields,  $\mathcal{E}_p(\Omega, \nu)$ , arriving at the antennas from different directions are uncorrelated, common assumptions in remote sensing of "natural" scenes [14]. These assumptions can be represented formally by writing:

$$\langle \mathcal{E}_p(\Omega, \nu) \mathcal{E}_q^*(\Omega', \nu') \rangle = S_{pq}(\Omega, \nu) \delta(\nu - \nu') \delta(\Omega - \Omega') \quad (7)$$

where  $S_{pq}(\Omega, \nu)$  is the cross-spectral density associated with the incident electromagnetic field. (See Appendix C for a discussion of the meaning of  $S_{pq}(\Omega, \nu)$  and the use of Fourier transforms in this context.) Using Equation 7, one obtains:

$$\langle V_{pq} \rangle = \sqrt{(A_p A_q)} \int \int S_{pq}(\Omega, \nu) \mathcal{A}_p(\Omega, \nu) \mathcal{A}_q^*(\Omega, \nu) H_p(\nu) H_q^*(\nu) d\Omega d\nu \quad (8)$$

Because of the assumed stationarity, the expected value of the radiometer output,  $\langle V_{pq}(t) \rangle$ , does not depend on time, and the notation has been simplified to reflect this.

When the passband of the receiver,  $H_{p,q}(\nu)$ , is narrow compared to the scale of change with frequency of the spectral density and the antenna, one has approximately:

$$\langle V_{pq} \rangle \approx \sqrt{(A_p A_q)} \int S_{pq}(\Omega, \nu_0) \mathcal{A}_p(\Omega, \nu_0) \mathcal{A}_q^*(\Omega, \nu_0) d\Omega \int H_p(\nu) H_q^*(\nu) d\nu \quad (9a)$$

$$= B_W H_{pq}^0 \left\{ \sqrt{(A_p A_q)} \int S_{pq}(\Omega, \nu_0) \mathcal{A}_p(\Omega, \nu_0) \mathcal{A}_q^*(\Omega, \nu_0) d\Omega \right\} \quad (9b)$$

where  $\nu_0$  is the center frequency of the radiometer receiver and

$$B_w = \left\{ \int H_p(\nu) H_q^*(\nu) d\nu \right\} / H_p(\nu_0) H_q^*(\nu_0) \quad (10)$$

$$H_{pq}^0 = H_p(\nu_0) H_q^*(\nu_0) \quad (11)$$

The bandwidth,  $B_w$ , defined in Equation 10 is the common definition of “noise-equivalent bandwidth” [2c, 4]. It is implicit in the definitions above that the gain of the system is a maximum at the center frequency,  $\nu_0$ .

### III. Antenna Temperature

The convention used in radiometry is to express the output as a temperature,  $T$ , by equating the output power to the noise power available from a resistor at this temperature. At microwave frequencies (i.e. in the Rayleigh-Jeans approximation) one has: [15,16] :  $W = kTB_w$ . In order to obtain the radiometer output in units of power, notice that  $\langle V_{pq} \rangle / \eta$  has units of power. The choice of the impedance,  $\eta = \sqrt{\epsilon/\mu}$ , for the normalization is justified by the application to the observation of electromagnetic fields and Poynting’s theorem (e.g. see Appendix B). Dividing both sides of Equation 9 by  $\eta$  one has:

$$\langle V_{pq} \rangle / \eta = k T B_w \quad (12)$$

$$= \sqrt{(A_p A_q)} B_w \int |S_{pq}(\Omega) / \eta| \mathcal{A}_p(\Omega) \mathcal{A}_q^*(\Omega) d\Omega \quad (13)$$

For convenience, in Equation 13 the system gain has been set to unity ( $H_{pq}^0 = 1$ ) and the explicit dependence of  $S_{pq}(\Omega)$  and  $A_{p,q}(\Omega)$  on frequency  $\nu_0$  has been omitted. Equation 13 is the sum of the incident power over all directions weighted by the effect of the antenna. From Equation 13, it can be seen that the dimensions of  $S_{pq}(\Omega) / \eta$  are Watts/(meter<sup>2</sup>-steradian-Hz). These are the dimensions of “brightness” [1a]. (In optics

this quantity is called “spectral radiance” and in microwave radiometry the name “spectral brightness” has also been used [2d]

To obtain results in conventional form, the effective area in Equation 13 is replaced by the antenna beam “solid angle” [1b]:

$$A_p = \lambda^2 / \Omega_{Bp} \quad (14)$$

where  $\lambda$  is evaluated at the center frequency  $\nu_0$  and  $\Omega_{Bp}$  is the integral over the normalized antenna pattern. Equating the right-hand sides of Equations 12 and 13 and using Equation 14, one obtains:

$$T_{pq}^A = [1 / \sqrt{(\Omega_{Bp} \Omega_{Bq})}] \int (\lambda^2 / \eta k) S_{pq}(\Omega) \mathcal{A}_p(\Omega) \mathcal{A}_q^*(\Omega) d\Omega \quad (15)$$

The term,  $T_{pq}^A$ , in Equation 15 is a measure of the output power of the radiometer and is called the “antenna temperature”.

#### IV. Modified Stokes Parameters

In the special case  $p = q$ , Equation 15 becomes:

$$T_{pp}^A = (1 / \Omega_{Bp}) \int (\lambda^2 / \eta k) S_{pp}(\Omega) P_{np}(\Omega) d\Omega \quad (16)$$

where  $P_{np} = \mathcal{A}_p(\Omega, \nu) \mathcal{A}_p^*(\Omega, \nu)$  is the normalized antenna power pattern [2b]. Comparing Equation 16 with Equation A6 (Appendix A) one sees that the term  $(\lambda^2 / \eta k) S_{pp}(\Omega)$  in Equation 16 plays the role of the brightness temperature of the source:

$$\begin{aligned} T_{pp}(\Omega) &= \text{brightness temperature of the source at polarization, } p \\ &= (\lambda^2 / \eta k) S_{pp}(\Omega) \end{aligned} \quad (17)$$

Alternatively, one could use the discussion below Equation 13 or in Appendix B identifying  $S_{pp}(\Omega)/\eta$  with brightness. Then, assuming an unpolarized source and using the Rayleigh-Jeans approximation for applications to observations in the microwave spectrum, one has:

$$\begin{aligned} S_{pp}(\Omega)/\eta &= \text{Brightness at polarization, } p \\ &= k T_{pp}(\Omega)/\lambda^2 \end{aligned} \quad (18)$$

which is the same as Equation 17. The factor of 2 in the Rayleigh-Jeans approximation is not present above because this is the power at a single polarization.

The definition of brightness temperature can be generalized by adapting the relationship in Equation 17 to the general case of mixed polarization:

$$T_{pq}(\Omega) = (\lambda^2/\eta k) S_{pq}(\Omega) \quad (19)$$

The temperature on the left hand side of Equation 19 is a brightness temperature (a characteristic of the source) in contrast to Equations 15 or 16 where the temperature on the left hand side represents the output of the measurement system (antenna temperature).

Finally, adopting the notation of modified Stokes parameters for brightness temperature as used in polarimetric radiometry [3], one can write Equations 19 in the form of a four-element vector:

$$[T_{pq}] = \begin{bmatrix} T_{pp} \\ T_{qq} \\ 2\text{Re } T_{pq} \\ 2\text{Im } T_{pq} \end{bmatrix} = \begin{bmatrix} T_v \\ T_h \\ T_3 \\ T_4 \end{bmatrix} = (\lambda^2/\eta k) \begin{bmatrix} S_{pp}(\Omega) \\ S_{qq}(\Omega) \\ 2\text{Re } S_{pq}(\Omega) \\ 2\text{Im } S_{pq}(\Omega) \end{bmatrix} \quad (20)$$



The notation  $[T_v, T_h, T_3, T_4]$  in the middle set of brackets in Equation 20 is what is called in radiometry, “Modified Stokes Parameters in Brightness Temperature” and assumes that  $v = p$  and  $q = h$ .

## V. Generalized Brightness

It is also possible to use the relationships above (e.g. Equations 18 and 19) as the basis for defining a generalized brightness temperature for sources with mixed polarization:

$B_{pq} = S_{pq}(\Omega) / \eta$ . Following the procedure above, one can define a 4-vector brightness:

$$[B_{pq}] = \begin{bmatrix} B_{pp} \\ B_{qq} \\ 2 \operatorname{Re} B_{pq} \\ 2 \operatorname{Im} B_{pq} \end{bmatrix} = 1 / \eta \begin{bmatrix} S_{pp}(\Omega, \nu) \\ S_{qq}(\Omega, \nu) \\ 2 \operatorname{Re} S_{pq}(\Omega, \nu) \\ 2 \operatorname{Im} S_{pq}(\Omega, \nu) \end{bmatrix} \quad (21)$$

The results can also be written in matrix form:

$$[B_{pq}] = \begin{bmatrix} B_{pp} & B_{pq} \\ B_{pq}^* & B_{qq} \end{bmatrix} = \begin{bmatrix} S_{pp}(\Omega, \nu) / \eta & S_{pq}(\Omega, \nu) / \eta \\ S_{pq}(\Omega, \nu)^* / \eta & S_{qq}(\Omega, \nu) / \eta \end{bmatrix} \quad (22)$$

The matrix defined in Equation 22 has the form of the coherency matrix defined in optics [17a]. The terms in Equation 22 have dimensions of brightness. However, normalizing by the factor  $B_o = (\sqrt{S_{pp}S_{qq}}) / \eta$  yields a matrix of dimensionless elements which is identical to the “degree of coherence” defined in optics [17a]:

$$\mu_{pq} = [B_{pq}] / B_o \quad (23)$$

Following the optics definition, the special case of unpolarized radiation (i.e. natural, thermal radiation), is defined to be the case when  $\mu_{pq} = \delta_{pq}$  (i.e. zero when  $p \neq q$  and 1 when  $p = q$ ). From thermodynamic arguments in this case (Planck law and the Rayleigh-Jeans approximation) one has that:  $B_o = k T / \lambda^2$ . Assuming unpolarized radiation, and using Equation 23 and Equation 22, one has:

$$B_{pp} + B_{qq} = [ S_{pp}(\Omega, \nu) + S_{qq}(\Omega, \nu) ] / \eta \quad (24a)$$

$$= 2 k T / \lambda^2 \quad (24b)$$

The term on the right in Equation 24b is just the Rayleigh-Jeans approximation for the brightness of an unpolarized source. From the discussion above, it is clear that it applies to unpolarized, “natural” radiation and represents the total power, the sum of both degrees of freedom (both polarizations).

The same information is contained in the modified Stokes parameters. Using Equations 20 and 22, it is also possible to express the brightness in terms of the modified Stokes parameters:

$$[B_{vh}] = (k / \lambda^2) \begin{bmatrix} T_v & (T_3 + i T_4)/2 \\ (T_3 - i T_4)/2 & T_h \end{bmatrix} \quad (25)$$

Comparing the expression above with case of plane waves [17a] suggests some important special cases:

1. Natural radiation:  $T_3 = T_4 = 0$  and  $T_v = T_h$ ;
2. Linearly polarized radiation:  $T_4 = 0$ ;
3. Reflected natural radiation:  $T_3 = T_4 = 0$  and  $T_v \neq T_h$ .

Item 3 above is the circumstance encountered when microwave radiation from a thermal source such as the Sun or Moon is reflected from a surface such as the Earth to the observer. This is a common occurrence in microwave radiometry and points out the need

for a more generalized form for scene brightness than the classical Rayleigh-Jeans approximation:  $B = 2 k T / \lambda^2$ . It is possible in this case that  $T_3 \neq 0$  and/or that  $T_4 \neq 0$ . The former can occur due to polarization rotation such as occurs in the ionosphere (e.g. Faraday rotation) or due to simple misalignment of the antenna polarization vectors. The latter ( $T_4 \neq 0$ ) is possible with scattering from rough surfaces when polarization mixing occurs [18].”

## VI. Discussion

Equations 20 are the “Modified Stokes Parameters in Brightness Temperature”. Writing them in the format of Equations 1, one obtains:

$$T_v = [\lambda^2 / \eta k] \langle S_{vv}(\Omega, \nu) \rangle \quad (26a)$$

$$T_h = [\lambda^2 / \eta k] \langle S_{hh}(\Omega, \nu) \rangle \quad (26b)$$

$$T_3 = [\lambda^2 / \eta k] 2 \operatorname{Re} \langle S_{vh}(\Omega, \nu) \rangle \quad (26c)$$

$$T_4 = [\lambda^2 / \eta k] 2 \operatorname{Im} \langle S_{vh}(\Omega, \nu) \rangle \quad (26d)$$

The dependence on  $\Omega$  and  $\nu$  on the left-hand side of these expressions has been suppressed:  $T_v = T_v(\Omega, \nu)$ . The parameters  $T_v$ ,  $T_h$ , etc on the left side of Equations 26 are characteristics of the scene to be used in integral expressions such as Equation A6 (Appendix A) to compute the radiometer output. The dimensions on the left-hand side are Kelvin/steradian [19] which is consistent with this application (i.e. integration by the antenna of the radiation per unit solid angle incident from a given direction).

Notice that the radiometer system bandwidth,  $B_w$ , does not appear in these expressions. This is reasonable since Equations 26 are parameters of the scene (brightness) and should be independent of the measurement device. These expressions are also dimensionally

consistent which can be seen by recalling that  $S_{pq}(\Omega, \nu) / \eta$  has units of brightness and that Boltzmann's constant has units of Joule/Kelvin.

Writing Equations 26 in terms of electric fields, for example as done in Equations 1, is problematic because of the issues associated with defining Fourier transforms in the case of stationary random processes. One can avoid this issue by using the definition of the spectral density:

$$S_{pq}(\nu) = F[ R_{pq}(\tau) ] \quad (27)$$

where  $F[\bullet]$  denotes a Fourier transform and  $R_{pq}(\tau)$  is the correlation function for the electric fields incident on the antenna from direction  $\Omega$ :

$$R_{pq}(\tau) = \langle e_p(t + \tau) e_q^*(t) \rangle \quad (28)$$

The problem occurs when one tries to rewrite these expressions in terms of the Fourier transforms of the fields. In order to accommodate the assumption that the random process is stationary, one should use the definition in Appendix C:

$$S_{pq}(\nu, \Omega) = \lim_{T \rightarrow \infty} \{ \langle E_p(\nu, \Omega) E_q^*(\nu, \Omega) \rangle / 2T \} \quad (29)$$

However, it is appealing to try to preserve the notation in Equations 1 (i.e. the use of electric fields on the right-hand side in forms such as  $\langle |E_\nu|^2 \rangle$ ). For example, one might make a simple substitution of  $\langle \mathcal{E}_p(\Omega, \nu) \mathcal{E}_q^*(\Omega, \nu) \rangle$  for  $S_{pq}(\Omega, \nu)$  with the understanding that the limit in Equation 29 is implied. The difficulty with this approach is that it is dimensionally misleading. In particular,  $\langle | \mathcal{E}_p(\Omega, \nu) |^2 \rangle$  suggests units of  $(\text{Volt}/\text{meter} \cdot \text{Hz})^2$  whereas  $S_{pq}(\Omega, \nu)$  in Equation 29 has units of  $(\text{Volt}/\text{meter})^2/\text{Hz}$ .

## VII. References

1. J.D. Kraus, Radio Astronomy, McGraw-Hill, 1966.
  - a. Chapter 3
  - b. Section 6.2.
2. Ulaby, F.T., R. K. Moore and A.K. Fung, Microwave Remote Sensing, Addison-Wesley Publishing Co, 1981.
  - a. Section 1-2.2
  - b. Section 3-2.4
  - c. Section 6-7.2 (Equation 6.62)
  - d. Section 4-2.1
  - e. Section 4-2.2
  - f. Section 4-5.3.
3. Matzler, C., Thermal Microwave Radiation: Applications for Remote Sensing, IET Electromagnetic Wave Series, London, UK, 2006 (Section 4.4.3).
4. Randa, J., Recommended Terminology for Microwave Radiometry, NIST TN 1551, August, 2008; Avail US Government Printing Office; Also see: [http://www.boulder.nist.gov/div818/81801/Noise/publications/noise\\_pubs.html](http://www.boulder.nist.gov/div818/81801/Noise/publications/noise_pubs.html).
5. GRSS, <http://www.ieee-grss.org/> see “Technical Resources” and then “Radiometer Dictionary”, 2008.
6. Claassen, J.P. and A. K. Fung, “The Recovery of Polarized Apparent Temperature Distributions of Flat Scenes from Antenna Temperature Measurements”, IEEE Trans. Antennas & Propagation, Vol AP-22 (no. 3), pp. 433-442, May, 1974.
7. Johnson, J., J.A. Kong, R.T. Shin, D. H. Staelin, K. O’Neill and A.W. Lohanick, “Third Stokes Parameter Emission from a Periodic Water Surface”, IEEE Trans Geoscience and Remote Sensing, Vol 31 (#5), pp 1066-1080, September, 1993.
8. Colliander, A., J. Kettunen and M.T. Hallikainen, “Calibration of End-to-End Phase Imbalance of Polarimetric Radiometers”, IEEE Trans Geoscience and Remote Sensing, Vol 44 (#10), pp 2635-2641, October, 2006.
9. Skou, N and D. M. Le Vine, Microwave Radiometer Systems: Design and Analysis, Artech House, 2006, Chapter 7.
10. Thompson, A.R., J.M. Moran and G.W. Swenson, Interferometry and Synthesis in Radio Astronomy, New York, Wiley, 1986

11. Martin-Niera, M., Ribo, S., and Matin-Polegre, A.J., "Polarimetric Mode of MIRAS", *IEEE Trans. Geosci. & Remote Sensi.*, Vol 40, No 8, pp 1755- 1768, August, 2002.
12. Corbella, I., N. Duffo, M. Vall-llossera, A. Camps, F. Torres, The Visibility Function in Interferometric Aperture Synthesis Radiometry, *IEEE Transactions Geoscience and Remote Sensing*, Vol 42 (8), pp. 1677-1682, August 2004, Digital Object Identifier 10.1109/TGRS.2004.830641,
13. Collin, R.E. and F.J. Zucker, Antenna Theory , Vol 1, Chapter 4, McGraw-Hill, 1969.
14. Rytov, S, Y. Kratsov and V. Tatarskii, Principles of Statistical Radiophysics, Elements of Random Fields, Vol 3, Chapter 3, Springer-Verlag, 1989.
15. Janssen, M.A., Atmospheric Remote Sensing by Microwave Radiometry, John Wiley and Sons, 1993, Section 1.3.1.
16. Stelzried, C. T., "Microwave Thermal Noise Standards", *IEEE Trans. Microwave Theory and Techniques*, Vol MTT-16 (no. 9), pp 646-665, 1968.
17. Born, M and E. Wolf, Principles of Optics, Pergamon Press, 1959.
  - a. Section 10.8
  - b. Section 10.2.
18. Tsang, L., Xu. P. and Chen, K.S. " Third and Fourth Stokes Parameters in Polarimetric Passive Microwave Remote Sensing of Rough Surfaces over Layered Media", *Microwave and Optical Technology Letters*, vol. 50, no. 12, pp. 3063-3069, Dec. 2008.
19. Ruf, C.S., C.T. Swift, A. B. Tanner and D. M. Le Vine, "Interferometric Synthetic Aperture Microwave Radiometry for the Remote Sensing of the Earth", *IEEE Trans. Geoscience and Remote Sensing*, Vol 26, No 5, pp597-611, September, 1988.
20. Jordan, E.C. and K.C. Balmain, Electromagnetic Waves and Radiating Systems, Section 13.07, Prentice-Hall, 2 ed, 1968.
21. Jones, D.S., *Methods in Electromagnetic Wave Propagation*, Oxford Engineering Science Series, Clarendon Press, Oxford, Section 9.8, 1979.

## **VIII. Appendix A: Traditional Radiometer Response**

The power,  $W_p$ , available at the output of an antenna with polarization  $p = \{v,h\}$  when looking at an unpolarized source with brightness,  $B(\Omega, \nu)$ , is [1a, 2e]:

$$W_p = (1/2) A_e \iint B(\Omega, \nu) P_{np}(\Omega, \nu) d\Omega d\nu \quad (A1)$$

where  $A_e$  is the effective area of the antenna and  $P_n$  is the normalized antenna pattern.

Assume that the Rayleigh-Jeans approximation applies:

$$B(\Omega, \nu) = 2 k T(\Omega, \nu) / \lambda^2 \quad \text{W/m}^2\text{-sr-Hz} \quad (A2)$$

and use

$$W_p = k T_{pp}^A B_W \quad (A3)$$

on the left side of Equation A1 to express the output power in bandwidth  $B_W$  in terms of the change in temperature,  $T_{pp}^A$ , of a resistor at the output. Then, Equation A2 can be written:

$$T_{pp}^A B_W = A_e \iint T(\Omega, \nu) \lambda^{-2} P_{np}(\Omega) d\Omega d\nu \quad (A4)$$

If  $T(\Omega, \nu)$  and  $P_{np}$  are independent of frequency over the passband of the measurement system and the bandwidth,  $B_W$ , is narrow compared to the center frequency (usually a good approximation for remote sensing observations of thermal sources), then  $B_W$  will cancel on both sides. Finally, using [1b,2b]:

$$A_e = \lambda^2 / \Omega_B \quad (A5)$$

where  $\Omega_B$  is the antenna solid angle, Equation A4 becomes:

$$T_{pp}^A = (1 / \Omega_B) \iint T(\Omega) P_{np}(\Omega) d\Omega \quad (A6)$$

Equation A6 is the classic result relating the antenna temperature,  $T_{pp}^A$  at polarization,  $p$ , to the source brightness temperature  $T(\Omega)$  [2f]. It applies to a single polarization and assumes that the source and antenna parameters that are essentially constant over the bandwidth of the measurements.

## IX. Appendix B: Brightness and Electromagnetic Fields

The objective of this appendix is to establish the relationship between the source brightness and the electromagnetic fields incident at the radiometer antenna.

### A. Time Average Poynting Vector

The time average of the power per unit area arriving from a direction  $\mathbf{n}$  (i.e. crossing a plane with unit normal,  $\mathbf{n}$ , located at the antenna) can be expressed in terms of the incident electromagnetic fields using Poynting's theorem:

$$W/A = \langle \mathbf{E}(r,t) \times \mathbf{H}(r,t) \rangle_t \cdot \mathbf{n} \quad (\text{B1})$$

where  $W$  is the power passing through a plane with area  $A$  and unit normal  $\mathbf{n}$ ; and where,  $\mathbf{E}$  and  $\mathbf{H}$  are the electric and magnetic field intensities, respectively, and  $\langle \bullet \rangle_t$  denotes a time average, and "x" denotes the "vector" or "cross product".

In order to evaluate Equation B1, it is convenient to represent the field by their Fourier transform and do the analysis on the transforms:

$$\mathbf{E}(r,t) = \int_{-\infty}^{\infty} \mathbf{E}(r,\nu) \exp(-j2\pi\nu t) d\nu \quad (\text{B2})$$

To express the fields in the frequency domain we assume that the sources are far away and adopt the radio astronomy model by considering the radiation from sources in a small solid angle  $d\Omega$  in the direction  $\Omega$  as illustrated in Figure 2. Consider a sphere of radius  $R$  surrounding the observer (antenna) as shown in Figure 2. The radius  $R$  is assumed to be large compared to wavelength but small enough that all sources are outside the sphere.

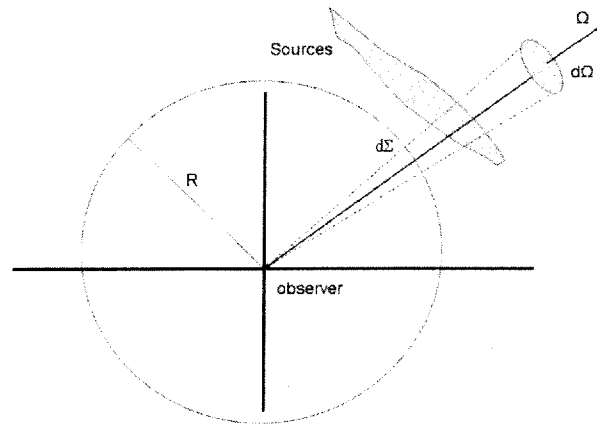

Figure 2: Geometry for computing incident electromagnetic radiation



The electromagnetic fields at the observer can be written in terms of the electric field in the aperture  $d\Sigma$  where the cone  $d\Omega$  crosses the sphere. Since  $R$  is large, one obtains approximately [20]:

$$d\mathbf{E}(r,v) \approx \mathbf{e} \mathcal{E}(\mathbf{K},v) \exp(j k R) / R d\Sigma \quad (\text{B3a})$$

$$d\mathbf{H}(r,v) \approx \mathbf{K} \times \mathbf{e} \mathcal{E}(\mathbf{K},v) \exp(j k R) / \eta R d\Sigma \quad (\text{B3b})$$

where  $k = 2\pi\nu/c$  is the wave number and  $\mathbf{K}$  is a unit vector in the direction of propagation from  $d\Sigma$  to the observation point and  $\mathbf{e}$  is an arbitrary, unit amplitude, polarization vector.

To compute the power available at the observer (antenna), the fields from all apertures are added and the time average of the Poynting vector of the total field is computed. Using the fact that  $\mathbf{E}(r,t)$  is real (the Fourier transform is hermitean), one can write this in the following form:

$$\begin{aligned} \langle \mathbf{E}(r,t) \times \mathbf{H}(r,t) \rangle_t &= \langle (1/\eta) \iint_{-\infty}^{\infty} \iint_{-\infty}^{\infty} \mathbf{p}(\mathbf{K},\mathbf{K}') \mathcal{E}(\mathbf{k}) \mathcal{E}^*(\mathbf{k}') \exp[j 2\pi(\nu-\nu')t] \dots \\ &\quad \dots \exp[j 2\pi(\mathbf{k}-\mathbf{k}')R] d\nu d\nu' d\Sigma(\mathbf{K}) d\Sigma(\mathbf{K}')/R^2 \rangle_t \end{aligned} \quad (\text{B4})$$

where

$$\mathbf{p}(\mathbf{K},\mathbf{K}') = [ \mathbf{e}_k \times (\mathbf{K}' \times \mathbf{e}_{k'}) ] \quad (\text{B5})$$

The fields propagating in the direction  $\mathbf{K}$  in each aperture,  $d\Sigma$ , in Figure 2 are composites of radiation from many sources (all the sources in the solid angle  $d\Omega$ ) and will be modeled as a random process. We consider the case of “natural” or “thermal” radiation in which case it will be assumed that the radiation from different apertures (directions,  $\mathbf{K}$ ) is uncorrelated and that the process is ergodic and stationary [14].

Ergodicity permits replacement of the time average in Equation B4 with the statistical (ensemble) average. Because the process is stationary and the fields in different patches are uncorrelated, one can express the average as:

$$\langle \mathbf{E}(\mathbf{K}, \nu) \mathbf{E}^*(\mathbf{K}', \nu') \rangle = S_E(\mathbf{K}, \nu) \delta(\nu - \nu') \delta(\mathbf{K} - \mathbf{K}') \quad (\text{B6})$$

and Equation B4 becomes:

$$\langle \mathbf{E}(r,t) \times \mathbf{H}(r,t) \rangle = (1/\eta) \int \int \mathbf{K} S_E(\mathbf{K}, \nu) \nu \, d\Sigma(\mathbf{K})/R^2 \quad (\text{B7})$$

Recognizing that  $d\Sigma(\mathbf{K}')/R^2 = d\Omega$  where  $\Omega$  denotes solid angle, one can write:

$$\langle \mathbf{E}(r,t) \times \mathbf{H}(r,t) \rangle = (1/\eta) \int \int \mathbf{K}(\Omega) S_E(\Omega, \nu) \nu \, d\Omega \quad (\text{B8})$$

The function,  $S_E(\Omega, \nu)$ , in Equation B8 is the power spectral density of the electric fields arriving from a given direction  $(\theta, \phi)$  per unit solid angle,  $\Omega$ . It is not the power spectral density of the electric field at the antenna but, rather, a “directional” power spectral density. See Appendix C for a discussion of the spectral density in this context.

Also, note that Equation B8 is independent of distance,  $R$ , the radius of the sphere in Figure 2. This is to be expected because the fields in Equations B3a-b are radiation fields and the radiated power is conserved.

## B. Brightness and Electric Field

From Equation B8, the dimensions of  $S_E(\Omega, \nu)/\eta$  are seen to be “power/(unit area – steradian – Hz)” which are the same as those of brightness,  $B(\Omega, \nu)$  in Appendix A. In addition, comparison of Equations A1 and B8 shows that  $S_E(\Omega, \nu)/\eta$  and  $B(\Omega, \nu)$  play the same role in describing the incident power. The difference is that the antenna has not been included in Equation B8. Doing so would result in identical expressions and allow us to make the identification:

$$\begin{aligned} B(\Omega, \nu) &= W/(m^2\text{-Hz-sr}) \\ &= S_E(\Omega, \nu)/\eta \end{aligned} \quad (\text{B9})$$

Notice that  $S_E(\Omega, \nu)/\eta$  represents the total power available (i.e. from both polarizations) and in this sense differs from  $S_{pq}(\Omega, \nu)/\eta$  defined in the text. The advantage of the

approach adopted in the text is that it handles polarization explicitly (see Section V). In the case of unpolarized radiation:

$$S_E(\Omega, \nu) = S_{pp}(\Omega, \nu) + S_{qq}(\Omega, \nu) \quad (\text{B10})$$

## X. Appendix C: Fourier Transforms

The transition from Equations 6 to 8 is obtained by recognizing that the given assumptions (incident fields that are stationary and uncorrelated in direction) imply that the expected value of the integrals over frequency and direction is equivalent to the sum over only those terms for which  $\nu = \nu'$  and  $\Omega = \Omega'$  and zero otherwise. This result is formally equivalent to using Equation 7 in Equation 6.

The function,  $S_{pq}(\nu, \Omega)$ , on the right hand side of Equation 7 is the cross-spectral density in the classical sense (Fourier transform of the cross-correlation function):

$$S_{pq}(\nu) = F [ R_{pq}(\tau) ] = F [ \langle e_p(t + \tau) e_q^*(t) \rangle ] \quad (\text{C1})$$

where the dependence on  $\Omega$  has been suppressed. One could try to write Equation C1 in terms of the Fourier transforms of  $e_p(t)$  and  $e_q(t)$  in order to relate it to the incident electromagnetic fields. However, the assumption of stationarity presents some mathematical problems for the existence of Fourier transforms (because the functions must extend to infinity).

This issue is formally handled by defining the cross-spectral density  $S_{pq}(\nu, \Omega)$  in a limiting sense using the Fourier transform of functions with a defined time window in the limit as the width of the window,  $T$ , becomes infinite [17b, 21]:

$$S_{pq}(\nu, \Omega) = \lim_{T \rightarrow \infty} \{ \langle E_p(\nu, \Omega) E_q^*(\nu, \Omega) \rangle / 2T \} \quad (\text{C2})$$

where bold face,  $\mathbf{E}_p(\nu, \Omega)$ , indicates Fourier transform of  $e_p(t)$  defined over the finite interval,  $-T < t < T$ . As a check, the dimensions on the right-hand side of Equations C2 and C2 are equal and that the dimensions of  $S_{pq}(\nu, \Omega) / \eta$  are those of “brightness”:  $W/(m^2\text{-Hz-sr})$ .