

CONFIDENTIAL

Copy 1  
RM SE57K25

12/30/57

NACA RM SE57K25

Source of Acquisition  
CASI Acquired



# RESEARCH MEMORANDUM

for the

Bureau of Aeronautics, Department of the Navy

ENDURANCE EVALUATION OF SINTERED, POROUS, STRUT-

SUPPORTED TURBINE BLADES MADE BY FEDERAL-

MOGUL-BOWER-BEARINGS, INCORPORATED,

UNDER BUREAU OF AERONAUTICS

CONTRACT NOas 55-124-C

By Robert O. Hickel and Hadley T. Richards

Lewis Flight Propulsion Laboratory  
Cleveland, Ohio

Restriction/Classification Cancelled

DOCUMENT

A law prohibiting the unauthorized disclosure of information relating to the national defense of the United States within the meaning of the espionage laws, Title 18, U.S.C., Secs. 793 and 794, the transmission or revelation of which in any manner to unauthorized person is prohibited by law.

## NATIONAL ADVISORY COMMITTEE FOR AERONAUTICS

WASHINGTON

December 20, 1957

CLASSIFICATION CANCELLED  
CONFIDENTIAL

FILE COPY

To be returned to  
the file of the  
Advisory Committee  
for Aeronautics  
Washington, D. C.

22

RESTRICTION CANCELLED  
CONFIDENTIAL  
NACA PUBLICATIONS  
NATIONAL BUREAU OF AERONAUTICS  
Date \_\_\_\_\_

Restriction/Classification Cancelled

ENDURANCE EVALUATION OF SINTERED, POROUS, STRUT-SUPPORTED TURBINE

BLADES MADE BY FEDERAL-MOGUL-BOWER-BEARINGS, INCORPORATED,

UNDER BUREAU OF AERONAUTICS CONTRACT NOas 55-124-C

By Robert O. Hickel and Hadley T. Richards

ABSTRACT

Four strut-supported, transpiration-cooled turbine blades were investigated experimentally in a turbojet engine. The blade shells were fabricated by the mold-sintering method with spherical stainless-steel powder. Two blades were investigated in order to evolve suitable capping methods for the blade tip. Two other blades were used to evaluate the durability of the porous-shell material. The blades were investigated at a turbine-tip speed of 1305 feet per second, an average turbine-inlet temperature of about 1670° F, and at a porous-shell temperature limited to a maximum of approximately 1040° F.

INDEX HEADINGS

Turbine Cooling	3.7.2
Cooling - Gas Turbine Systems	3.10.2

RESTRICTION CANCELLED  
CONFIDENTIAL  
Restriction/Classification Cancelled



## NATIONAL ADVISORY COMMITTEE FOR AERONAUTICS

RESEARCH MEMORANDUM

for the

Bureau of Aeronautics, Department of the Navy

ENDURANCE EVALUATION OF SINTERED, POROUS, STRUT-SUPPORTED TURBINE

BLADES MADE BY FEDERAL-MOGUL-BOWER-BEARINGS, INCORPORATED,

UNDER BUREAU OF AERONAUTICS CONTRACT NOas 55-124-C

By Robert O. Hickel and Hadley T. Richards

## SUMMARY

An experimental investigation was made to evaluate the durability of a group of transpiration-cooled, strut-supported turbine blades made by the mold-sintering technique. The blades were fabricated for the Bureau of Aeronautics under contract NOas 55-124-C. Installation of tip caps, grinding of base serrations, and subsequent durability investigations in a turbojet engine were performed at the NACA Lewis laboratory.

All the blades submitted to the Lewis laboratory had very large random variations in the local permeability coefficient (from about  $30 \times 10^{-10}$  to  $80 \times 10^{-10}$  sq in. or more), as indicated by permeability tests made by the contractor. Because of these large variations in permeability, only four blades were investigated; two were used to develop a suitable method for capping the tips of the blades, and two were used for an extended durability investigation.

The use of sheet metal tip caps that were welded to the porous blade shells was found to be unsuitable because the caps broke away from the shell along the weld. A tip cap provided by building up a weld from the tip of the supporting strut to the blade shell appeared satisfactory. Two blades having built-up welded tip caps were subjected to a constant-engine-speed endurance investigation. The blades were operated at a turbine-inlet temperature of about  $1670^{\circ}$  F and a tip speed of 1305 feet per second. Cooling air was supplied to the test blades in a sufficient quantity so that the maximum temperature of the porous blade shell was about  $1040^{\circ}$  F. The ratio of cooling-air flow per blade to combustion-gas flow per blade was about 0.10. One blade failed after 3 hours and 40 minutes of operation. Practically the entire porous shell was stripped from the supporting strut. The failure of this blade was caused by an

inadequate bond between the shell and the lands of the strut. A second blade operated without failure for a total of 31 hours and 26 minutes. The porous shell of this blade appeared to be in very good condition except for some small cracks in the root region of the blade where the porous shell was attached to the blade platform.

From the limited successful operation of one blade, transpiration-cooled turbine blades made by the mold-sintering technique appear to have some potential from a structural standpoint for use in turbojet engines.

### INTRODUCTION

The Bureau of Aeronautics and the Office of Naval Research have been supporting for about ten years a program for the development of porous materials for application to transpiration-cooled turbine blades. There has been a need for such a program because, of the three basic air-cooling methods (forced convection, film cooling, and transpiration cooling), transpiration cooling is the most effective (ref. 1). Furthermore, the superiority of transpiration cooling relative to other methods becomes more pronounced at high turbine-inlet temperature levels (ref. 2). Porous materials, however, in their present stage of development require considerable amounts of research effort before they can be used successfully for air-cooled turbine-blade materials. Two of the major problems associated with porous-turbine-blade materials are the obtaining of adequate material strength and suitable permeability control. As part of the program for the development of porous materials for air-cooled turbine blades, the Bureau of Aeronautics placed a contract (NOas 55-124-C) in 1954 with the Federal-Mogul Division Research and Development, Federal-Mogul-Bower-Bearings, Incorporated. The contract called for the fabrication of twelve transpiration-cooled turbine blades that were to have a geometry and permeability specified by the Lewis laboratory. The porous blade shells were to be fabricated from stainless-steel powder by the mold-sintering technique developed by the contractor.

Past experience at the Lewis laboratory with porous materials generally had indicated that such materials in their present state of development did not have sufficient tensile strength to withstand the relatively high centrifugal loads imposed upon turbine blades by the high turbine rotational speed of aircraft gas-turbine engines. As a result, the porous-shell material fabricated by the contractor was attached to a supporting strut. The supporting struts were precision castings fabricated at the Lewis laboratory.

The purpose of this report is to present the endurance results that were obtained on four blades investigated in a turbojet engine. The blades were operated in an engine that was modified to accommodate several air-cooled turbine blades in an otherwise uncooled turbine. The

transpiration-cooled test blades were investigated at an engine speed of 11,500 rpm (rated engine speed), a turbine-inlet temperature of about 1670° F, and with sufficient cooling-air flow to maintain the maximum temperature of the porous-shell material at about 1040° F.

## APPARATUS

### Test Blades

The transpiration-cooled turbine blade investigated herein consisted of a sintered porous shell that was attached to a supporting strut. A supporting strut is required because the porous materials that are available at the present time do not possess sufficient strength to withstand the high centrifugal stresses imposed by the high rotational speeds of the turbine rotor. In addition to providing a means of supporting the porous blade shell, the strut also serves as a device for dividing the blade interior into a number of internal compartments or cooling-air channels. Such internal compartments are desirable so that the coolant flow through the porous blade wall can be distributed in a controlled manner. The amount of coolant that passes through the blade wall is dependent upon the difference in the squares of the absolute pressure on opposite sides of the wall. For a gas-turbine blade, the pressure around the outside wall varies considerably. If the wall were of uniform permeability and the pressure around the inside of the wall were also uniform, considerable flow variations through the wall would result. The use of compartments in the blade interior plus metering orifices in the blade base to control the airflow (and hence air pressure) to the various compartments minimizes local overcooling of the blade wall and the amount of cooling air required for transpiration-cooled blades (ref. 2). A detailed description of the porous sintered blade used herein and a discussion of the procedures used in its design are given in reference 3. Reference 4 describes in detail the procedures employed in fabricating the blades. The following paragraphs summarize the main features of the blade in a rather brief manner.

Strut. - Cross-sectional views of the supporting strut are illustrated in figure 1 for the root, midspan, and tip sections of the blade. The strut and blade base were an integral precision casting made from S-816 material. In order to simplify the design and fabrication, the strut was designed so that the outer contour of the supporting strut coincided with the outer contour of a standard uncooled blade of a current turbojet engine. This simplified the fabrication by making the master pattern from a standard turbine blade machined to the contour of the strut. There were twelve lands or fins on each strut (fig. 1) to which the shell was bonded. The width of each land was about 0.060 inch. The struts were fabricated at the Lewis laboratory and sent to the contractor for attachment of the sintered porous shells.

Shell. - The shell was made from type-302 modified stainless-steel powder (18 percent Cr, 8 percent Ni, and 5 percent Si) by the mold-sintering technique developed by the contractor (ref. 4). The process consists of first placing the cast strut in an injection mold. The cavity of the injection mold has a shape that is the same as the inner wall of the blade shell. A ceramic filler was pressure-injected into the mold in order to fill the depressions between strut lands. Upon removal of the strut from the mold, the strut lands and ceramic filler form a smoothly contoured airfoil that has the desired shape of the inner wall of the porous shell. The ceramic-filled strut was next placed in a sintering mold. The cavity in the sintering mold had the same shape as the outer contour of the blade shell; thus the sintering-mold cavity was larger than the injection-mold cavity by the desired thickness of the shell of the blade. The sintering mold was then filled with loose spherical stainless-steel powder having a -270+325 mesh fraction. The mold assembly was sintered for 4 hours in a dry hydrogen atmosphere at a temperature of 2190° F. After the first sinter the strut and porous-shell assembly was removed from the mold and given a second sinter at a temperature of 2220° F for 4 hours in a dry hydrogen atmosphere. After the final sinter, the ceramic filler was removed by vibrating the blade ultrasonically. A more detailed account of the mold-sintering technique and the development problems associated with applying the method to the fabrication of transpiration-cooled turbine blades is presented in reference 4. The spanwise thickness of the porous blade walls varied linearly from a value of 0.050 inch at the root to 0.030 at the tip. At any given spanwise position the shell thickness remained constant in a chordwise direction. A view of a blade after sintering and removal of the ceramic filler is shown in figure 2.

Base serrations and tip cap. - Before the blade can be operated in an engine, the base serrations must be ground, and a tip cap must be provided to prevent the cooling air from flowing out of the blade tip. Grinding of the base serrations and installation of a tip cap was done at the Lewis laboratory. Conventional serrations were ground into the blade base. Special care was exercised while grinding the base serrations to prevent cutting oil and grinding dust from impregnating the porous blade shell.

The blades as received from the contractor contained noticeable amounts of a powdery substance within the cooling-air passages. The material apparently was a residue of ceramic filler that was not completely eliminated from the blade by the ultrasonic-vibration removal method. It was felt that, if the blades were capped with the residual amounts of filler remaining in the coolant passages, the filler would eventually be loosened during engine operation, and clogging of the porous-shell material might result. In order to remove the remaining filler, the blades were placed in an available cold spin rig and spun at 12,650 rpm (10 percent above the design speed) for 20 minutes. The centrifugal forces

acting upon the residual filler at this high rotational speed loosened the filler and permitted it to be ejected from the blades through the open tips.

After removal of the filler, tip caps were attached to the blade. Two capping methods were employed. One consisted of welding a 0.015-inch-thick sheet metal cap to the porous metal shell at the extreme tip of the blade. The other method consisted of building up the tip cap entirely of weld material. This was done by applying weld material from the strut outward to the blade shell. After welding, the cap was ground to remove surface irregularities. The merits of the two capping methods will be discussed later. A view of a completed blade with a welded tip cap is shown in figure 3.

Metering orifices. - Reference 2 shows that metering orifices at the blade base for controlling the cooling-air flow to each compartment formed by the lands on the strut (fig. 1) can reduce the amount of cooling air required for transpiration-cooled blades. Furthermore, the use of orifices can result in simplified fabrication procedures for the porous shell, because shells having constant chordwise permeability can be employed. Control of the airflow through the shell at various chordwise positions can then be achieved by the metering orifice for each cooling-air compartment.

The blades fabricated by the contractor were expected to have a nearly uniform permeability, and metering orifices were to be installed in the blades at the Lewis laboratory. After the twelve blades were fabricated, the contractor determined the local permeability at eighteen positions on each blade shell. The results of this permeability investigation, given in reference 4, indicate that the average permeability coefficient  $K'$  for the individual blades ranged from a value of the order of  $45 \times 10^{-10}$  to about  $65 \times 10^{-10}$  square inch, which is considerably above the value of  $8 \times 10^{-10}$  square inch desired by NACA. The high values of  $K'$  resulted in part from a misunderstanding between the Lewis laboratory and the contractor, as discussed in reference 4. Of more importance than the actual permeability level was the fact that large random variations in local permeability existed in each blade. Generally the minimum local  $K'$  value for a given blade was of the order of  $30 \times 10^{-10}$  square inch, while the maximum local value was about  $80 \times 10^{-10}$  square inch. On several blades maximum  $K'$  values of over  $100 \times 10^{-10}$  square inch were obtained. Such large random variations in permeability are very undesirable because large variations in local blade wall temperature will result. For example, reference 5 shows that, for a turbine-inlet temperature of  $1600^\circ$  F, a random variation in  $K'$  of only  $\pm 10$  percent will result in a shell temperature variation of  $\pm 100^\circ$  F. For higher turbine-inlet temperatures the effects of random permeability variations on local shell temperature are even greater. Reference 5 also shows that orifices do not reduce temperature variations due to random variation in permeability. In fact the

reference shows that, in some cases of random permeability variations, the wall temperature variations are higher when an orifice is in series with the porous wall than when no orifice is used.

Because of the large random variation in permeability that existed in the blades, and because orifices might cause even larger variations in blade wall temperature, no attempt was made to provide metering orifices for the blades investigated herein. However, operation of the selected blades in a turbojet engine would provide information about their structural reliability even without orifices.

### Test Facility

The transpiration-cooled turbine blades were investigated in a commercial turbojet engine that was modified to accommodate two air-cooled turbine blades. The cooled turbine blades were located 180° apart in the turbine rotor. Cooling air for the cooled blades was supplied from an air-supply system that was external of the engine. A detailed description of the engine modifications that were necessary to modify a commercial engine for air-cooled-blade studies is given in reference 6. The engine used in the present investigation was essentially the same as that described in reference 6 except that, for the present investigation, an improved method of transferring cooling air from stationary to rotating parts was used. The improved method consisted of employing a balanced-pressure sliding seal between the stationary and rotating components of the cooling-air system, such as described in reference 7.

### Instrumentation

Thermocouples. - Thermocouples were installed on the transpiration-cooled test blades at the locations shown in figure 4. The blade numbers shown in figure 4 are those assigned to the blade during fabrication, and they are the same designations used by Federal-Mogul in reference 4. The thermocouples on blades 38 and 52 were located at about the 1/3-span position from the blade base, while those on blades 20 and 24 were about 1 inch from the blade tip.

Cemented thermocouples of the type discussed in detail in reference 8 were installed in the porous blade walls. The thermocouple installation procedure consisted of grinding a groove about 0.020-inch wide and 0.008-inch deep in the outer surface of the porous blade wall for each thermocouple to be installed. In order to minimize the effects that such a groove may have on the local blade permeability and also to minimize adverse structural-strength effects, the grooves were made opposite the lands on the strut. The grooves followed a strut land outward to the approximate point at which the actual thermocouple junction was to be



located. Inasmuch as the junctions were between strut lands or a strut land and the leading or trailing edge, the grooves were curved slightly near their terminal ends, as shown in figure 4. After the grooves were ground, they were coated with an electrical insulating ceramic. This coating was about 0.001-inch thick, and after application it was oven-dried. Chromel and Alumel wires having a diameter of 0.005 inch were placed in the grooves. After the wires were positioned in the grooves, the grooves were filled with ceramic cement and dried in an oven. In order to provide more rugged leads for the thermocouple wires after they reached the base of the blades, the wires were inserted in 2-hole ceramic insulating tubing and encased in stainless-steel tubing that had an outside diameter of about 0.040 inch. Figure 5 shows blades 20 and 24 completely instrumented and ready for installation in the turbine rotor; the ceramic-filled thermocouple grooves on the airfoils and the thermocouple leads on the blade bases can be seen.

After the test blades were installed in the turbine rotor, the leads from the thermocouples were fastened to the rear face of the turbine rotor by resistance-welded straps. The ends of the wire leads were fastened to junction posts at the rotor hub. From the junction posts the thermocouple leads were brought to the front of the engine through an axial hole on the centerline of the turbine and compressor shafts. At the front of the engine, the leads were connected to a slipring pickup, and the thermocouple electromotive force was then carried to a potentiometer through a suitable lead wire and selector switch system. A thermocouple system similar to that employed herein is discussed in detail in reference 8.

Temperature-indicating paints. - The porous, sintered, stainless-steel shell material does not exhibit high strength properties above a temperature of about 1200° F. Furthermore, at a shell temperature of the order of 1100° F, some oxidation of the shell material is likely to occur. Oxidized material particles might possibly clog the air passages within the porous material and result in permeability changes of the blade wall. Consequently, the blade shell temperature was limited to about 1000° F for safe operation. Because of the excessively large variation in permeability that existed in the blades as discussed previously, it was felt that local hot spots might occur in the blade shell. It is not practical to install large numbers of thermocouples on rotating turbine blades so that a detailed survey of the temperature distribution in the individual blade shells can be made. In order to supplement the thermocouples and to provide better assurance that local hot regions did not exist, two test blades (numbers 20 and 24) were coated with a temperature-indicating paint that exhibited a color change (from red-orange to yellow) at a temperature of 1040° F. A thin coat of paint was sprayed on the airfoil surface. A brief calibration test to determine whether the presence of the temperature-indicating paint would affect the permeability of the shell indicated that the paint had a negligible affect on the permeability.

## PROCEDURE

## Blades 38 and 52

Blades 38 and 52 were investigated first. These blades were received prior to the group of twelve contract blades and were used primarily to make exploratory tests, so that a suitable method for capping the blade tip could be developed. After the blades had base serrations ground and tip caps and thermocouples installed, they were operated simultaneously in the test engine at rated engine speed (11,500 rpm). This results in a turbine-tip speed of 1305 feet per second and a stress level at the root of the blade strut of about 30,000 psi. The average turbine-inlet temperature at rated engine speed was maintained at about 1670° F by means of an adjustable tailpipe nozzle. Prior to starting the engine, cooling air in an amount known to be considerably in excess of that required to cool the test blades was supplied from the laboratory cooling-air-supply system. After starting and upon setting the desired engine speed and turbine-inlet temperature, the cooling-air flow was reduced until the maximum shell temperature indicated by the thermocouples was 1000° F. The blades were then operated continuously until an engine shutdown was necessary.

## Blades 20 and 24

Blades 20 and 24 were operated at the same engine speed and turbine-inlet temperature as discussed previously for blades 38 and 52. The procedure for starting and adjusting the blade cooling-air flow at the beginning of the tests was the same as that discussed previously. However, because blades 20 and 24 were spray-painted with temperature-indicating paint to determine whether local hot regions existed in the blade shell, inspection of the blades was necessary after a short period of initial engine operation. Following the first engine start with blades 20 and 24 installed in the turbine, the engine was shut down after 15 minutes of running at the engine operating conditions mentioned previously. The cooled blades were inspected to determine whether the temperature-indicating paint showed color change and local overheating of the blades. If no overheating was indicated, operation of the engine at an engine speed of 11,500 rpm was resumed with the quantity of cooling air initially required to provide maximum shell temperature of 1000° F as indicated by the thermocouples. If local overheating of the blade shell was indicated, the blades were repainted and operated at some arbitrarily higher coolant flow than used previously. Inspection of the blades was made again after 15 minutes of engine operation, and the process was repeated until suitable cooling of a major portion of the blade shell was achieved. Once suitable shell temperatures were achieved, operation of the engine continued until a shutdown was necessary.

## RESULTS AND DISCUSSION

## Blades 38 and 52

As mentioned previously, blades 38 and 52 were used primarily to investigate methods for providing suitable tip caps for the porous blades. Two types of caps, namely, a sheet metal type and a completely welded built-up type, were investigated and are discussed in the following paragraphs.

Blades 38 and 52 were first operated in the test engine with sheet metal tip caps that were made of 0.015-inch-thick Inconel. In order to maintain the maximum shell temperature, as indicated by the thermocouples, at a value of 1000° F, a coolant-flow ratio (cooling-air weight flow per blade per combustion-gas weight flow per blade) of about 0.10 was required. After 42 minutes of operation at rated test conditions, blade 38 failed in the extreme tip region, as shown in figure 6. The failure was confined to the trailing-edge region of the blade and extended radially inward a maximum of 1/4 inch on the pressure surface (fig. 6(a)). The suction surface was undamaged except in the extreme tip region (fig. 6(b)). The failure apparently originated when the sheet metal cap broke away from the porous shell along the weld between the cap and blade shell.

When blade 38 failed, blade 52 was not damaged extensively. A very fine crack in the shell material of blade 52 was observed. The crack was on the pressure surface about 1/2 inch from the trailing edge, and it extended radially inward from the blade tip about 1/2 inch. Operation of blade 52 was continued with the crack in the shell until a total time of 5 hours and 19 minutes was accumulated at rated test conditions. At this time the blade failed in the tip region, as shown in figure 7. The damage to blade 52 was much more extensive than that on blade 38. However, the initial mode of failure was believed to be the same for both blades; that is, the tip cap broke away from the blade shell at the weld joint between cap and shell. After the failure of the tip cap occurred on blade 52, the engine probably was operated for a slightly longer period of time than for blade 38 before failure was detected. When failure of the tip cap occurs, cooling air is permitted to flow directly out of the blade tip rather than through the porous blade shell. This causes an increase in blade shell and strut temperature. Inasmuch as the shell material has little strength above a temperature of about 1200° F, portions of the shell can overheat locally and break away from adjacent parts of the shell. Overheating of the blade also might weaken the bond between the shell and strut lands and permit portions of the shell to break away from the strut. Examination of figure 7(a) indicates that possibly both modes of failure were present in the failure of blade 52.

Because of the large amount of damage, blade 52 was no longer operable. Blade 38, however, was repaired by grinding the tip back about 1/4

inch so that all the damaged tip area was removed. A new blade cap was installed by using a different capping method. Because the built-up welded cap was attached directly to the strut and did not depend upon the porous-shell material for support, this cap was believed to be more durable than the sheet metal cap used initially.

Blade 38 was reinstalled in the test engine and was investigated at the conditions mentioned previously. The blade was operated for 4 hours and 38 minutes with the built-up welded cap. Close inspection of the tip region of the blade indicated no failure or evidence of impending failure of the blade cap. Further investigation of blade 38 was arbitrarily stopped because at this time the group of blades actually submitted as fulfillment of the Bureau of Aeronautics contract became available.

During the investigation of blades 38 and 52, cracks appeared in the porous-shell material in the root of the blade where the shell joined the base platform (see figs. 6 to 8). The closeup view of the crack shown in figure 8 was typical of those found on both blades after operating only 42 minutes (time of first failure on blade 38). In an attempt to avoid such cracks, a fillet weld having about a 1/8-inch radius was provided at the root of blade 52 after it had been operated for 42 minutes. A similar fillet weld was provided on blade 38 when the built-up welded tip cap was provided. After the fillet weld was applied, no further evidence of cracking at the blade root was observed on either blade 38 or 52.

#### Blades 20 and 24

Blades 20 and 24 were part of the group of twelve blades fabricated to fulfill the Bureau of Aeronautics contract. Blades 20 and 24 were selected because they were among the blades having the lowest variation in local  $K'$  values. These blades also had average  $K'$  values (based on the 18 local  $K'$  values given for each blade in ref. 4) that most nearly approached the value of  $8 \times 10^{-10}$  square inch specified by Lewis laboratory.

When blades 20 and 24 were prepared for investigation in the test engine, tip caps of the built-up welded-type construction were provided. Also small fillet welds having a radius of about 1/8 inch were provided at the root of the blades between the base platform and the porous shell. The coolant-flow ratio required to maintain the shell temperature at a maximum of  $1040^{\circ}$  F was between 0.10 and 0.11.

Blade 20 failed after 3 hours and 40 minutes of rated engine speed operation. Essentially all of the blade shell separated from the strut, as shown in figure 9. Only a small amount of the blade shell remained at the extreme tip of the blade on the pressure surface (fig. 9(a)). The built-up welded tip cap also remained intact, as shown in figure 9.

Visual inspection of the strut of blade 20 after failure showed evidence of incomplete bonding of the shell material to the lands of the strut in many places. Possibly the shear strength of the attachment between the strut lands and the porous shell may have been inadequate; thus a portion of the shell may have broken away from the strut and caused a hole to form in the blade surface. If such a hole were large enough to cause a significant drop in the pressure of the cooling air inside the blade, airflow through the porous material would decrease. This could result in overheating of the shell with consequent loss of strength in the porous material and in the bond between shell and strut lands, and thus result in failure of the shell, as shown in figure 9. The thermocouple housings in figure 9 were installed in the strut before the porous shell was attached. At one time these housings were expected to be used for the installation of thermocouples incased in metal tubes (see the reference thermocouple of ref. 8). Accordingly, the tube-incased thermocouple would have been slid into the thermocouple housing and thus obtain a temperature in the strut. No strut temperatures were measured in the present investigation, and the housings were not used. When blade 20 failed, however, the housings apparently became dislodged and bent away from their original flush-mounted position in the strut.

The remaining blade (number 24) was not damaged, and operation of this blade was continued. Blade 24 was operated for a total of 31 hours and 26 minutes without failure. After this operation the blade shell was in generally good condition, as shown in figure 10. The built-up welded tip cap also showed no evidence of impending failure. The relatively large dark areas that can be seen near the leading edge on the suction surface of blade 24 (fig. 10(b)) were caused by a scorching effect that the combustion gases have upon the temperature-indicating paints after extended periods of operation. The blade spots also seen in figure 10(b) appeared to be small deposits of carbon that apparently impinged upon the blade and embedded themselves in the shell during operation.

Although there was no actual failure of the shell of blade 24, cracks occurred in the root region of the blade, as shown in figures 10 and 11. The cracks occurred in the shell material immediately adjacent to the fillet weld. These cracks started to appear after about 5 or 6 hours of operation and grew slightly with time for about another 5 hours. Inasmuch as the shell does not support any of the centrifugal load on the blade, the cracks are not particularly harmful from a structural standpoint. If they become large enough, however, excessive amounts of cooling air may flow out of the crack and cause other parts of the blade to overheat or require additional quantities of cooling air to satisfactorily cool the entire blade shell. Although the root cracks on blade 24 appeared to be rather large, they did not appear to alter the airflow requirements of the blade to a marked degree; this was concluded from the fact that, for a given cooling-air pressure at the inlet to the turbine rotor, the cooling-air flow remained constant with blade operating time. This also indicated that the carbon deposits mentioned previously did not appreciably affect the over-all permeability of the blade.



From this rather limited operation the investigation of blade 24 seemed to indicate that the shell material may have reasonable potential for application to a transpiration-cooled turbine blade from a structural standpoint. However, before the material can be seriously considered from a cooling standpoint, much better control of the local permeability variations must be achieved by the manufacturer. Because of the wide variation in permeability exhibited by these blades, any given blade will have wide variations in local temperature. The airflow required to maintain a given maximum shell temperature will result in other portions of the blade being considerably overcooled, and thus the total coolant flow to the blade will be excessively high. For example, in order to maintain a maximum blade wall temperature of 1040° F on blades 20 and 24, the coolant-flow ratio was about 0.10 to 0.11 at the rated test conditions. Based upon data presented in reference 9, a forced-convection air-cooled turbine blade with a corrugated insert, operating at the test conditions employed for investigating the porous blades discussed herein, would require a coolant-flow ratio of only about 0.03 to maintain its impermeable shell at a maximum temperature of about 1000° F. The failure of blade 20 indicates that a better mechanical bond between the shell material and the strut lands is probably required. Also, some method of preventing the cracks that occur in the root of the blade where the shell material joins the base platform is needed. Because of the shortcomings (particularly the large variations in local permeability) in the blades in the present stage of development, no further testing of the group of blades fabricated by the contractor was conducted.

#### SUMMARY OF RESULTS

The results of a durability investigation made in a turbojet engine with four transpiration-cooled, strut-supported turbine blades having shells fabricated by the mold-sintering technique are summarized as follows:

1. Two blades were used to develop a method of capping the blade tips. A method of providing a tip cap that consisted of a built-up weld extending from the strut to the porous shell appeared to be suitable. A sheet metal cap that was welded to the porous shell was unsatisfactory.
2. Two blades having built-up welded tip caps were subjected to steady-speed endurance evaluation. The ratio of cooling-air flow to combustion-gas flow on a per blade basis was about 0.10. One blade operated successfully for a total of 31 hours and 26 minutes. In general the shell was in good condition except for cracks in the root region of the blade where the shell was joined to the base platform. A second blade failed after 3 hours and 40 minutes of operation. Essentially the entire shell was stripped from the lands of the supporting strut; this indicated that the bond between the lands and sintered shell was not adequate.

3. From the limited successful operation of one blade, transpiration-cooled turbine blades made by the mold-sintering technique appear to have some potential for use in turbojet engines from a structural standpoint. However, before this type of blade can be considered from a cooling standpoint, much better control of local permeability must be achieved.

Lewis Flight Propulsion Laboratory  
National Advisory Committee for Aeronautics  
Cleveland, Ohio, November 26, 1957

#### REFERENCES

1. Eckert, E. R. G., and Livingood, John N. B.: Comparison of Effectiveness of Convection-, Transpiration-, and Film-Cooling Methods with Air as Coolant. NACA Rep. 1182, 1954. (Supersedes NACA TN 3010.)
2. Esgar, Jack B.: An Analytical Method for Evaluating Factors Affecting Application of Transpiration Cooling to Gas Turbine Blades. NACA RM E52G01, 1952.
3. Prasse, Ernst I., Livingood, John N. B., and Donoughe, Patrick L.: Design of Two Transpiration-Cooled Strut-Supported Turbine Rotor Blades. NACA RM E56A24, 1956.
4. Probst, Robert L., Karp, Phillip I., and Sayre, Charles H.: Investigation of the Fabrication of Strut Supported Stainless Steel Turbine Blades by Sintered Loose Spherical Powder Techniques and Possibility and Feasibility of Quantity Production Techniques. Div. Res. and Dev., Federal-Mogul-Bower-Bearings, Inc., Jan. 1957. (Contract NOa(s) 55-124-c.)
5. Esgar, Jack B., and Richards, Hadley T.: Evaluation of Effects of Random Permeability Variation on Transpiration-Cooled Surfaces. NACA RM E53G16, 1953.
6. Ellerbrock, Herman H., Jr., and Stepka, Francis S.: Experimental Investigation of Air-Cooled Turbine Blades in Turbojet Engine. I - Rotor Blades with 10 Tubes in Cooling-Air Passages. NACA RM E50I04, 1950.
7. Curren, Arthur N., and Cochran, Reeves P.: A Balanced-Pressure Sliding Seal for Transfer of Pressurized Air Between Stationary and Rotating Parts. NACA RM E56I11, 1957.

8. Stepka, Francis S., and Hickel, Robert O.: Methods for Measuring Temperatures of Thin-Walled Gas-Turbine Blades. NACA RM E56G17, 1956.
9. Bartoo, Edward R., and Clure, John L.: Experimental Investigation of Air-Cooled Turbine Blades in Turbojet Engine. XII - Cooling Effectiveness of a Blade with an Insert and with Fins Made of a Continuous Corrugated Sheet. NACA RM E52F24, 1952.

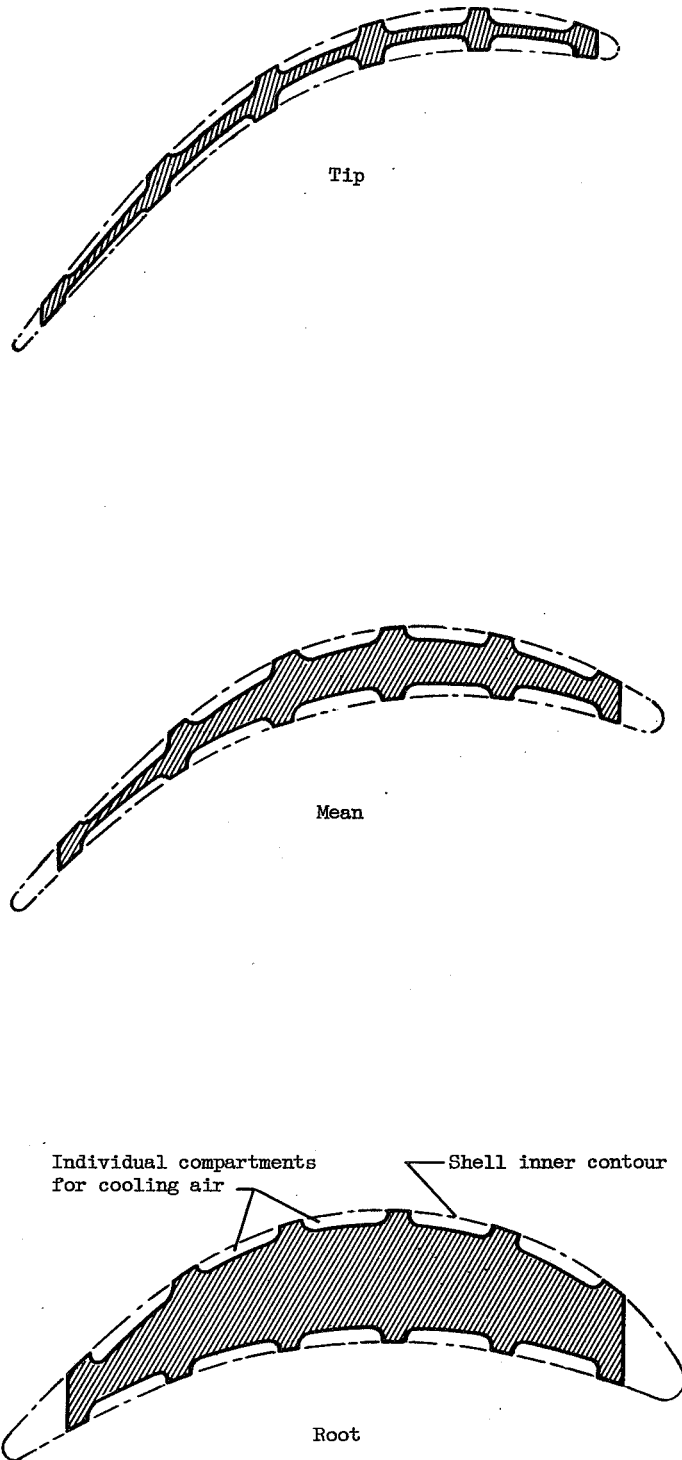

CD-4816

Figure 1. - Profile of strut for transpiration-cooled turbine blade at three radial positions.

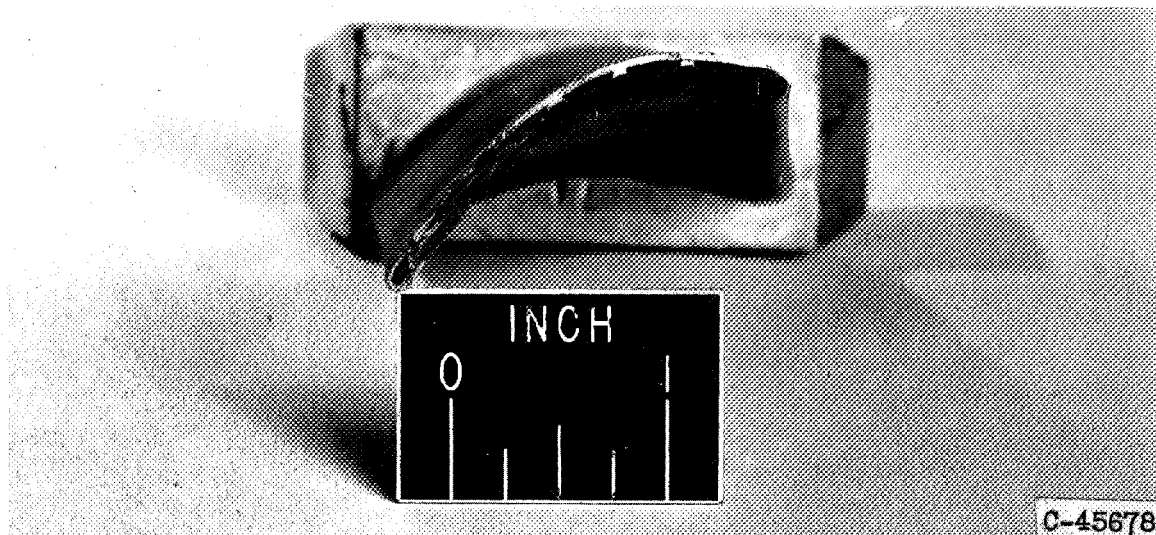

(a) Tip view.

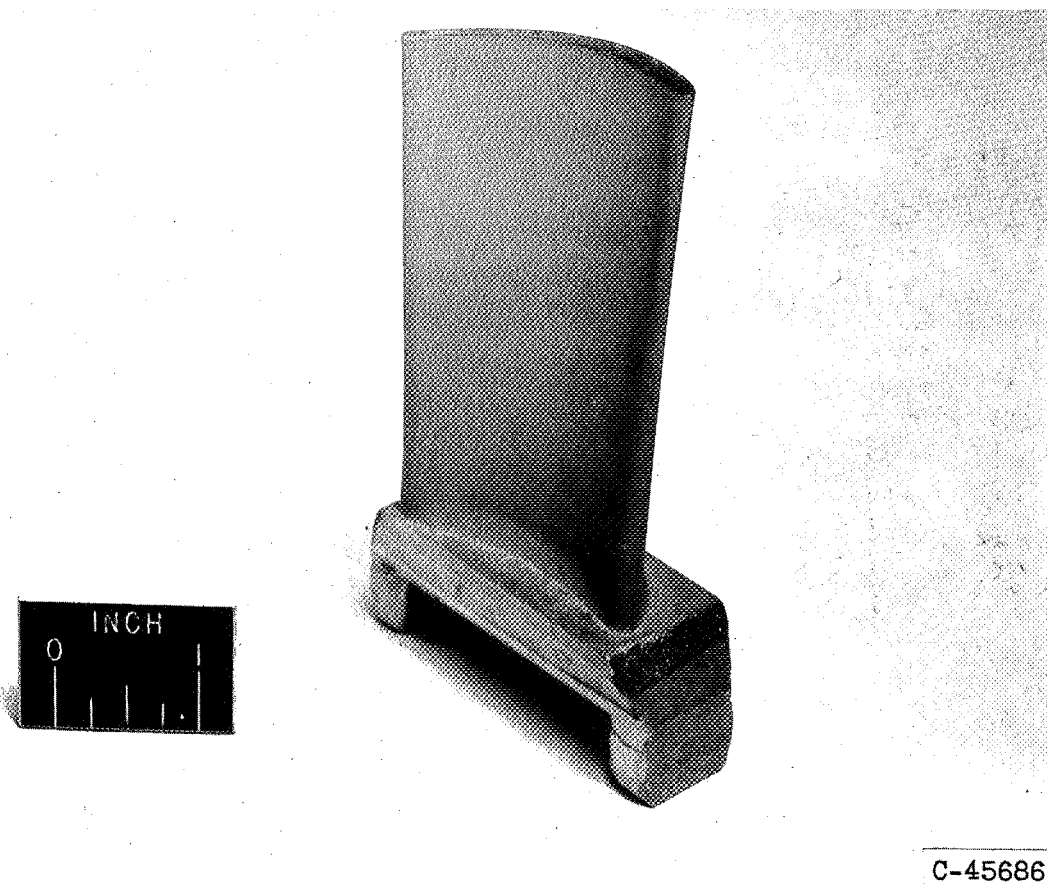

(b) Pressure surface.

Figure 2. - Porous, sintered stainless-steel blade after completion by contractor.



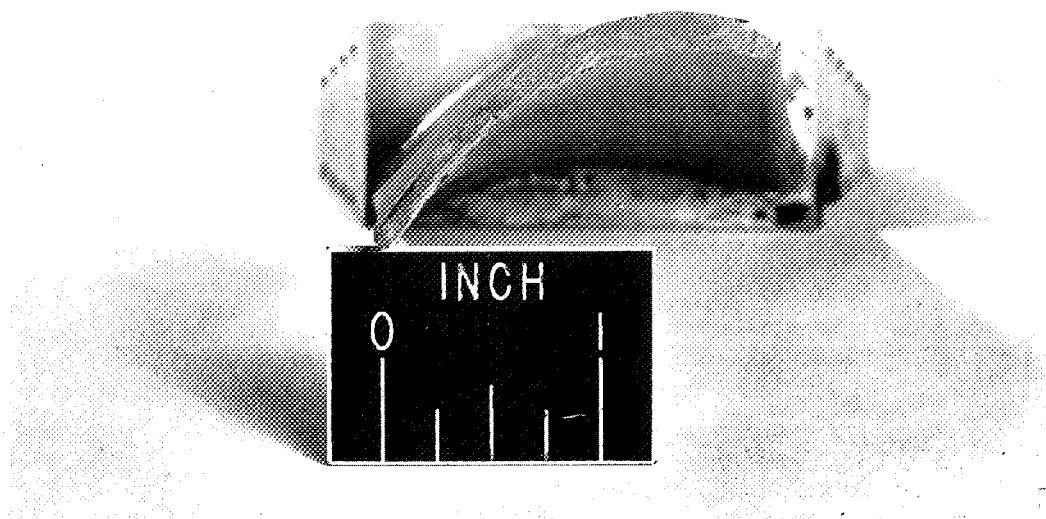

C-45684

(a) Tip view.

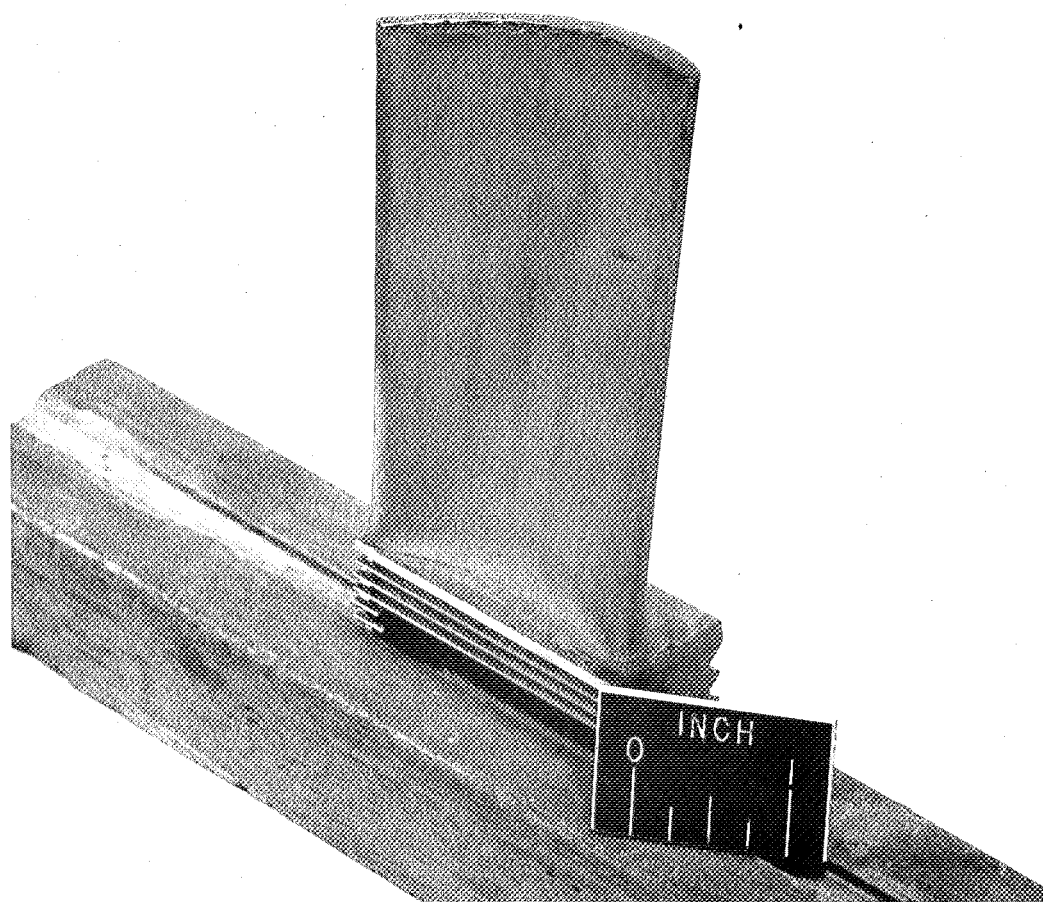

C-45681

(b) Pressure surface.

Figure 3. - Completed porous, sintered blade with welded tip cap and base serrations.

- Thermocouple locations on one of pair
- ▽ Thermocouple locations on second of pair
- Spanwise location

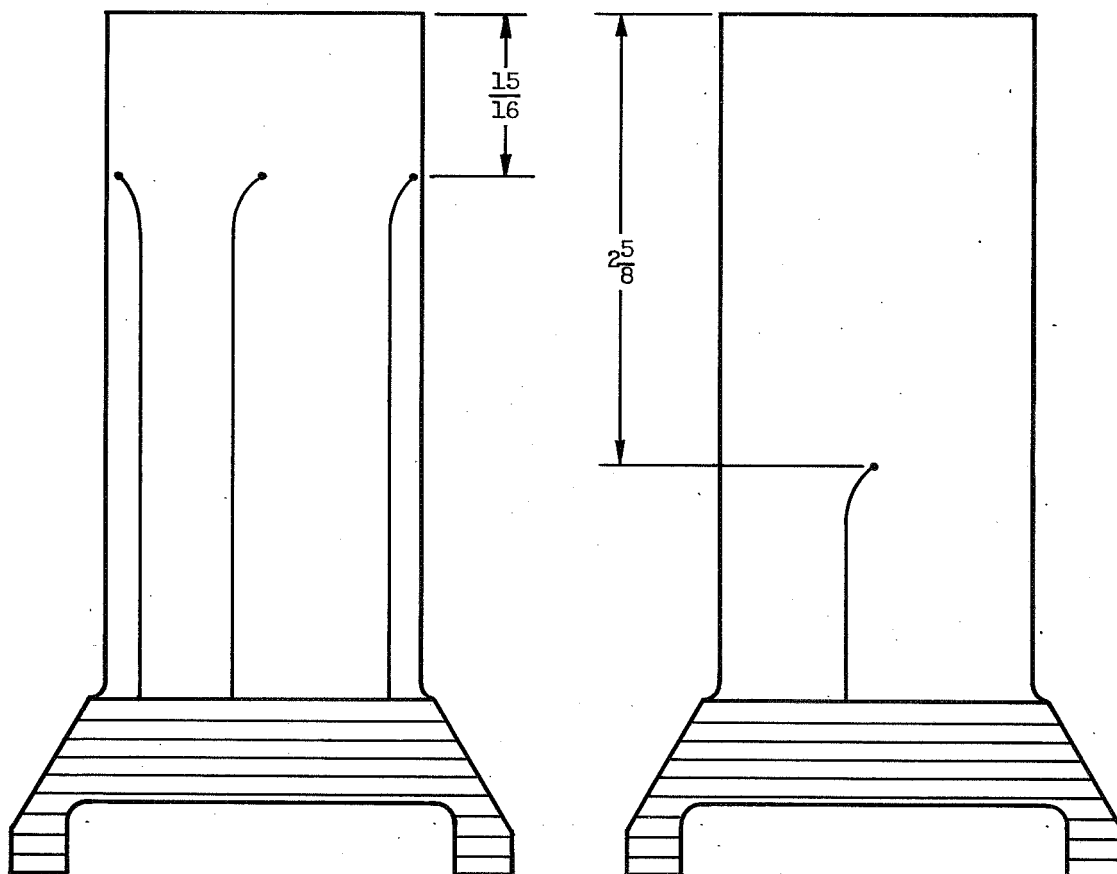

(a) Blades 20 and 24.

(b) Blades 38 and 52.

Figure 4. - Location of thermocouples for the two sets of test blades.  
(All dimensions in inches.)

CD-5898

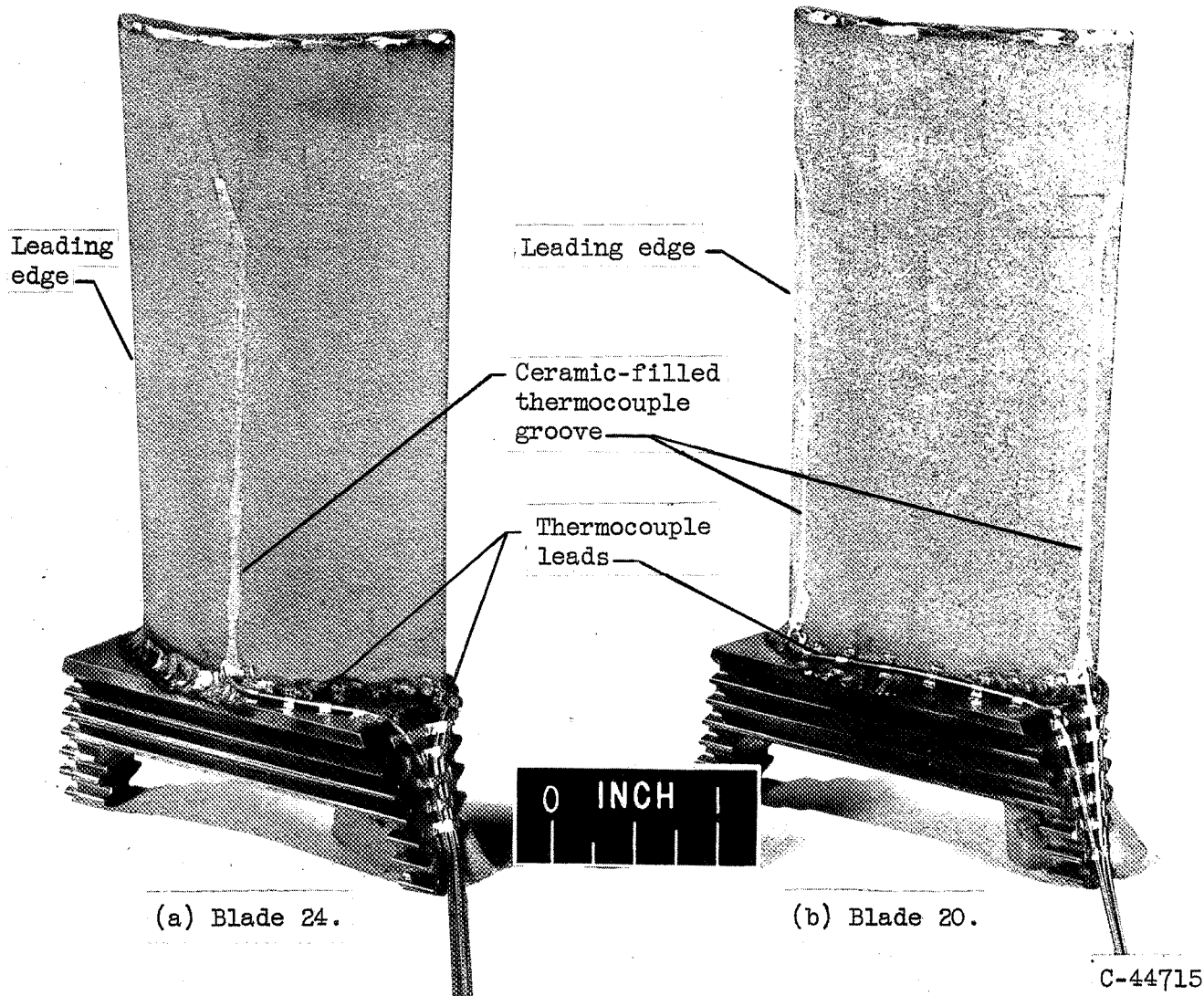

Figure 5. - Instrumented blades.

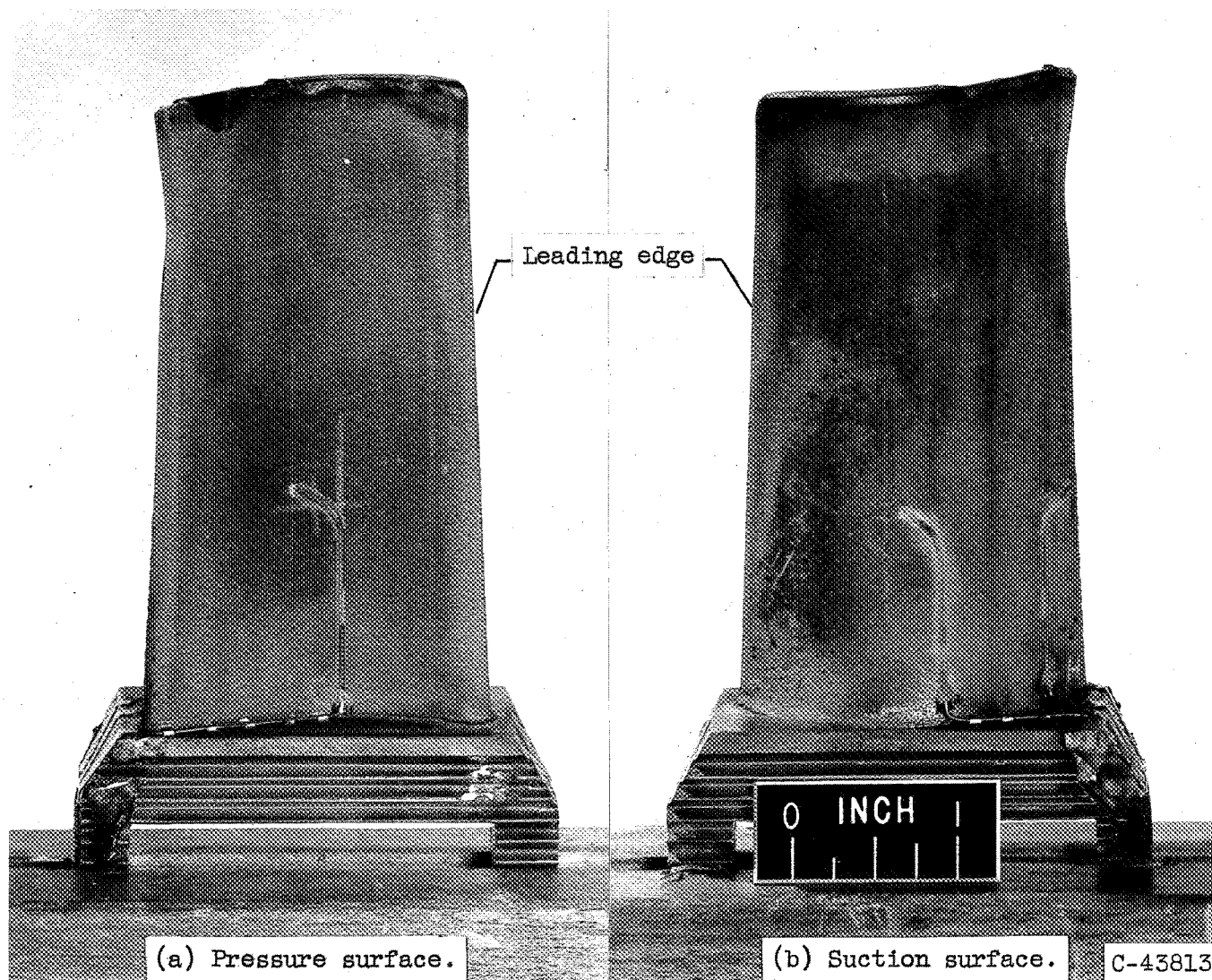

Figure 6. - Failure of tip region on blade 38.

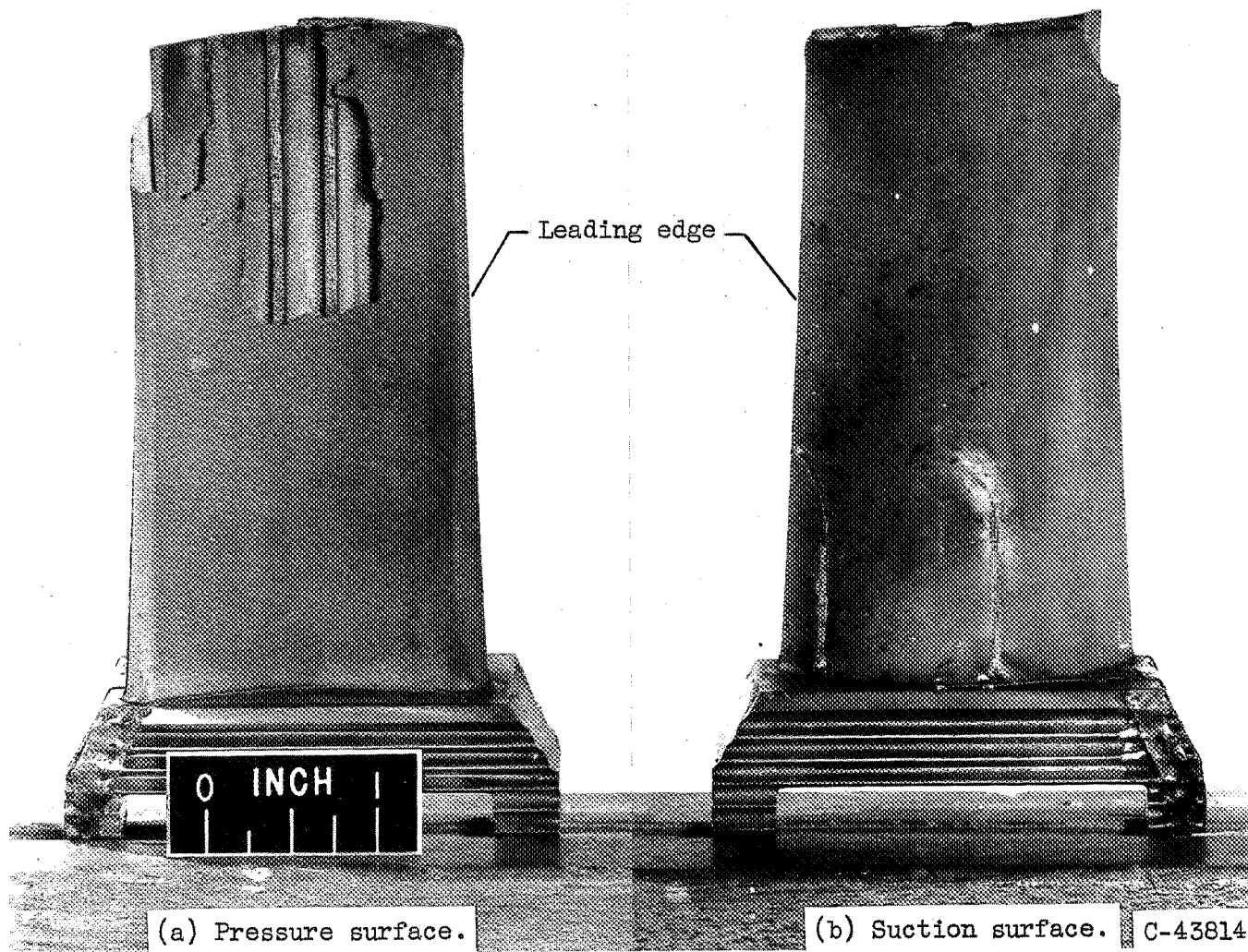

Figure 7. - Failure of shell and tip on blade 52.





C-43980

Figure 8. - Crack at junction of porous shell and base platform of blade 38.

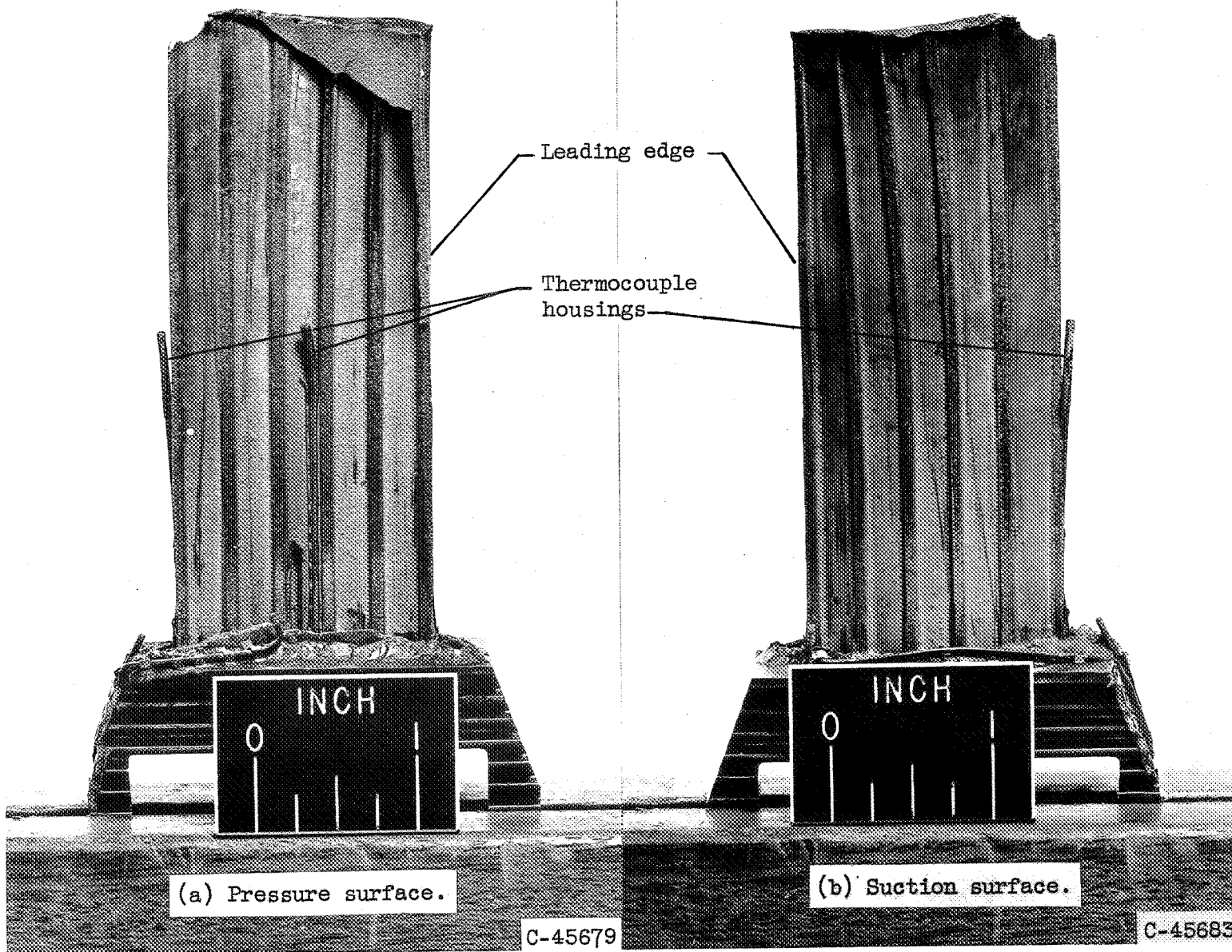

(a) Pressure surface.

(b) Suction surface.

C-45679

C-45683

Figure 9. - Failure of shell on blade 20.

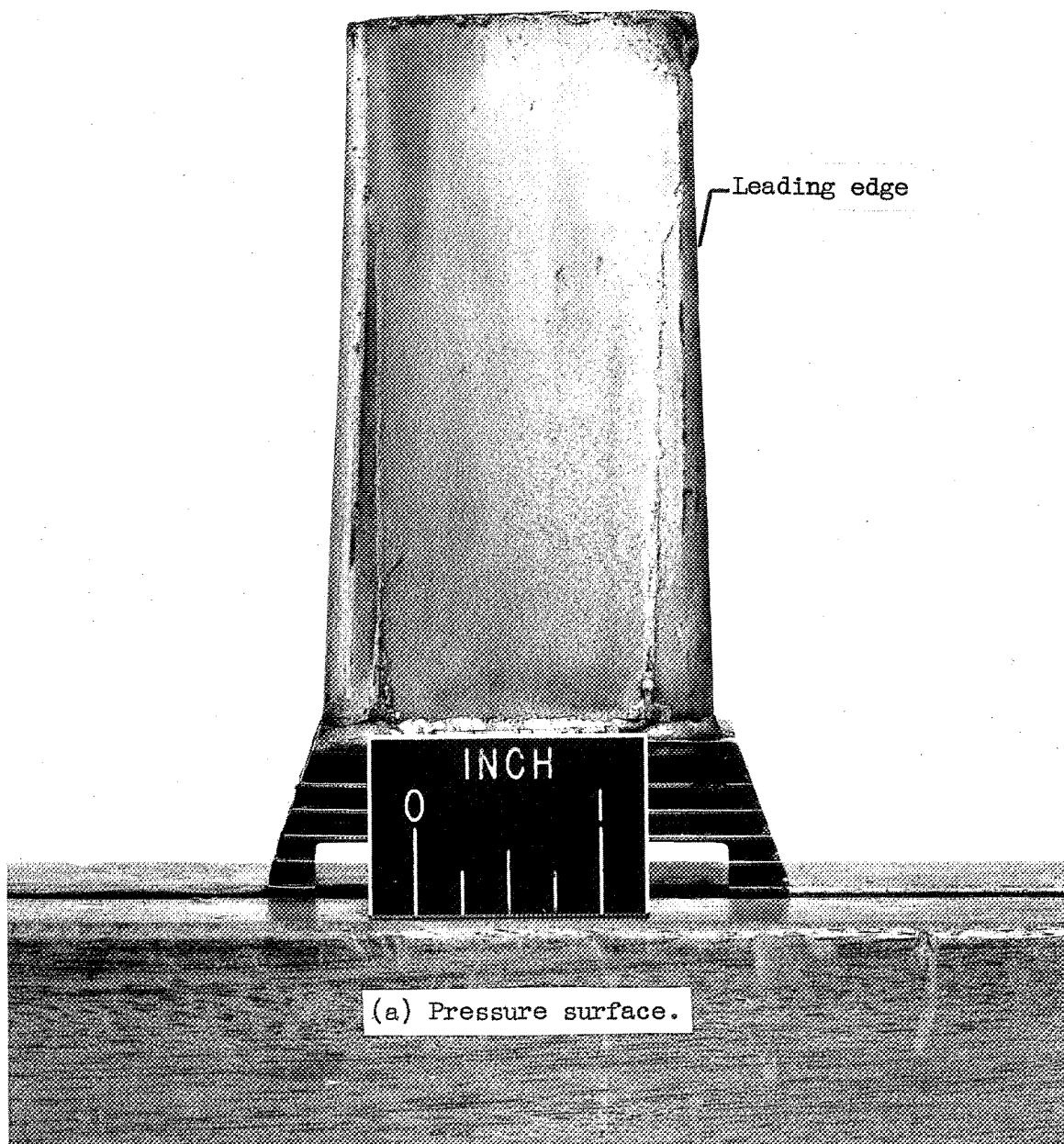
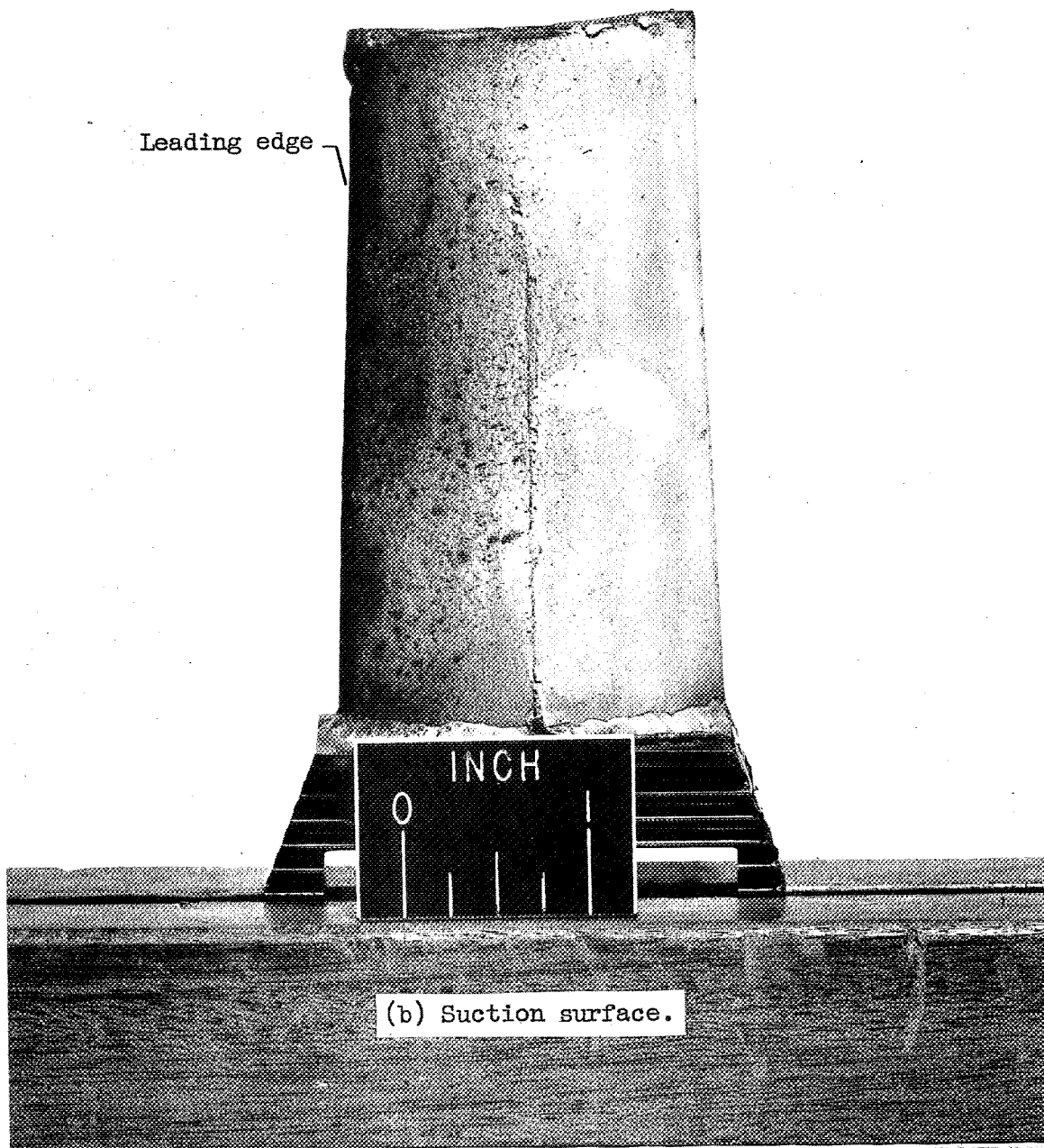

Figure 10. - Blade 24 after 31 hours and 26 minutes of rated-engine-speed operation.

3  
|  
#



C-45682

Figure 10. - Concluded. Blade 24 after 31 hours and 26 minutes of rated-engine-speed operation.

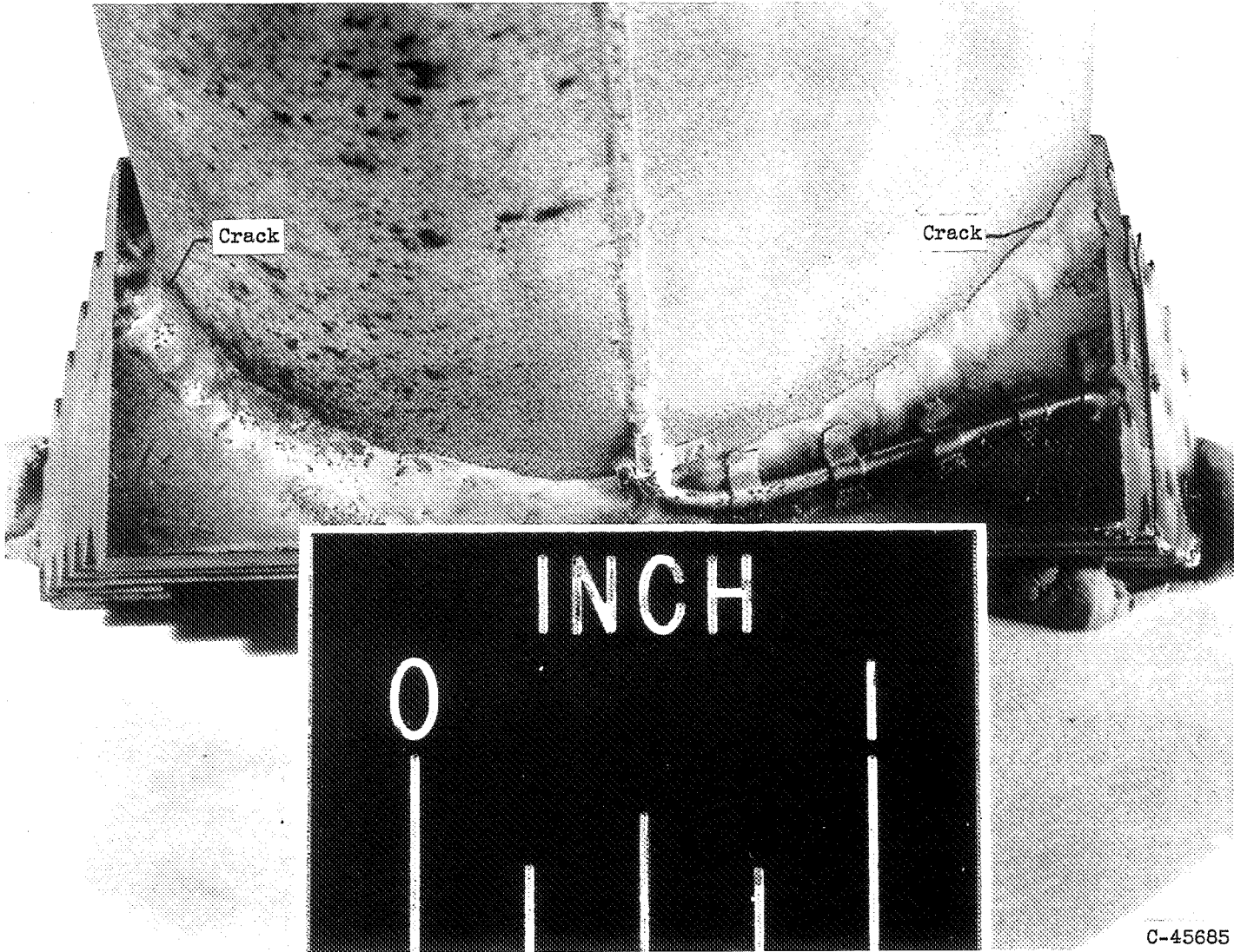

Figure 11. - Crack at junction of porous shell and fillet weld on blade 24.



ENDURANCE EVALUATION OF SINTERED, POROUS, STRUT-SUPPORTED TURBINE  
BLADES MADE BY FEDERAL-MOGUL-BOWER-BEARINGS, INCORPORATED,  
UNDER BUREAU OF AERONAUTICS CONTRACT NOas 55-124-C

By Robert O. Hickel and Hadley T. Richards

Robert O. Hickel

*Hadley T. Richards*  
Hadley T. Richards

Approved:

*Jack B. Esgar*  
Jack B. Esgar  
Chief,  
Structures Branch

*S. S. Manson*  
S. S. Manson  
Chief,  
Materials and Structures Division

aap  
11/26/57