

Elements of Regolith Simulant's Cost Structure

Why Rock is NOT Cheap

Doug Rickman
Earth Science Office, Marshall Space Flight Center
March 17, 2009



Complex Costs

- Development

- Advertising

- Overhead

- Scale, including Weight

Generally Present

- Acquisition

- Shipping

- Storage

- Processing

 - Milling

 - Measurement

 - Synthesis

- Profit, Risk and Time



Magnetic Separation Circuit

| Product | Weight | |
|-------------------------------|---------------|--------------|
| | g | % |
| Cleaner concentrate | 803.6 | 24.5 |
| Cleaner scavenger concentrate | 69.4 | 2.1 |
| Scavenger 2 concentrate | 1414.1 | 43.0 |
| Total Con | 2287.1 | 69.6 |
| Cleaner scavenger tails | 63.9 | 1.9 |
| Scavenger 1 tails and mids | 742.8 | 22.6 |
| Scavenger 2 tails and mids | 191.3 | 5.8 |
| Total Tails | 998.0 | 30.4 |
| Calculated Feed | 3285.1 | 100.0 |

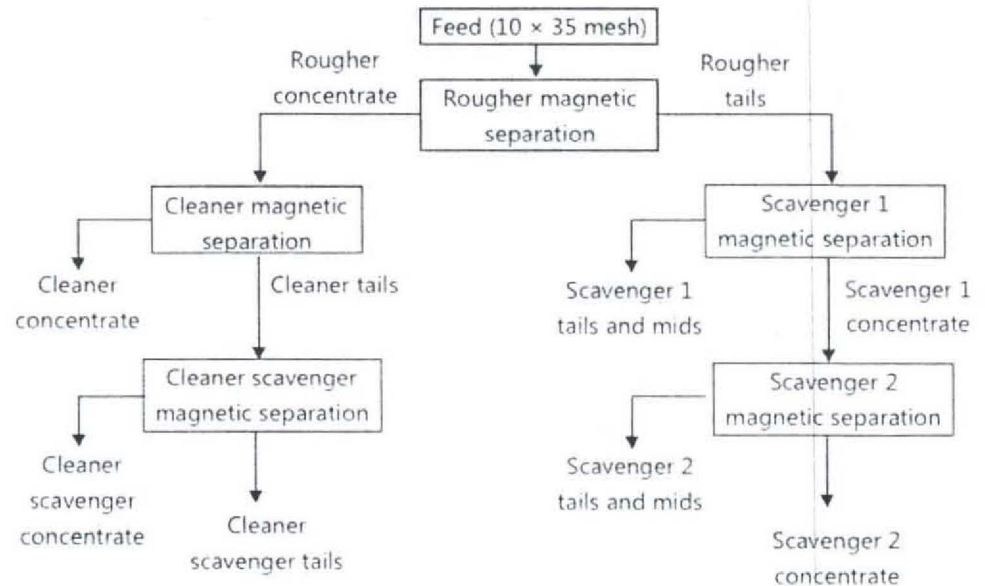

From a report by Hazen Research, Inc. to the USGS.



Crushing Circuit

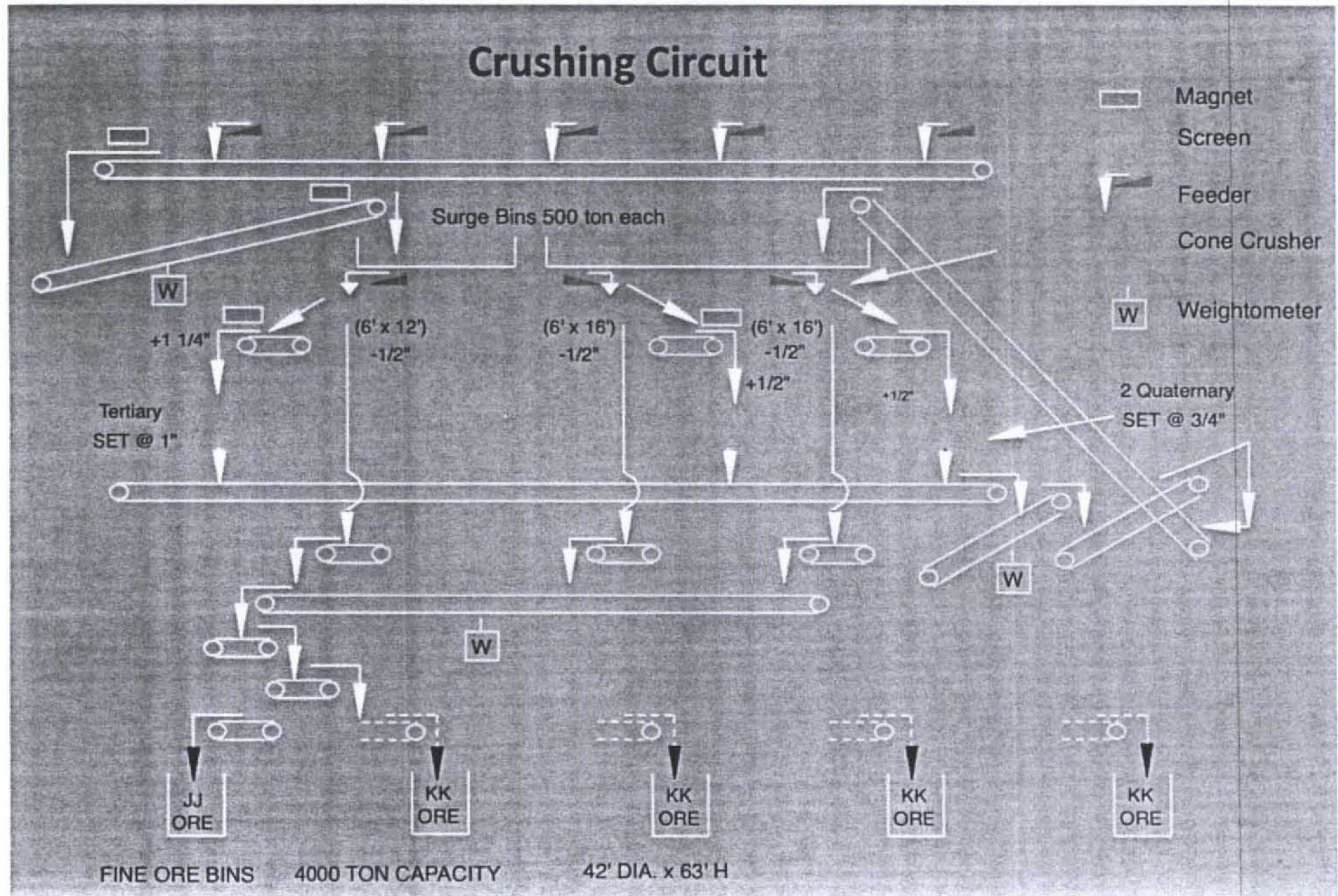

Flotation Circuit

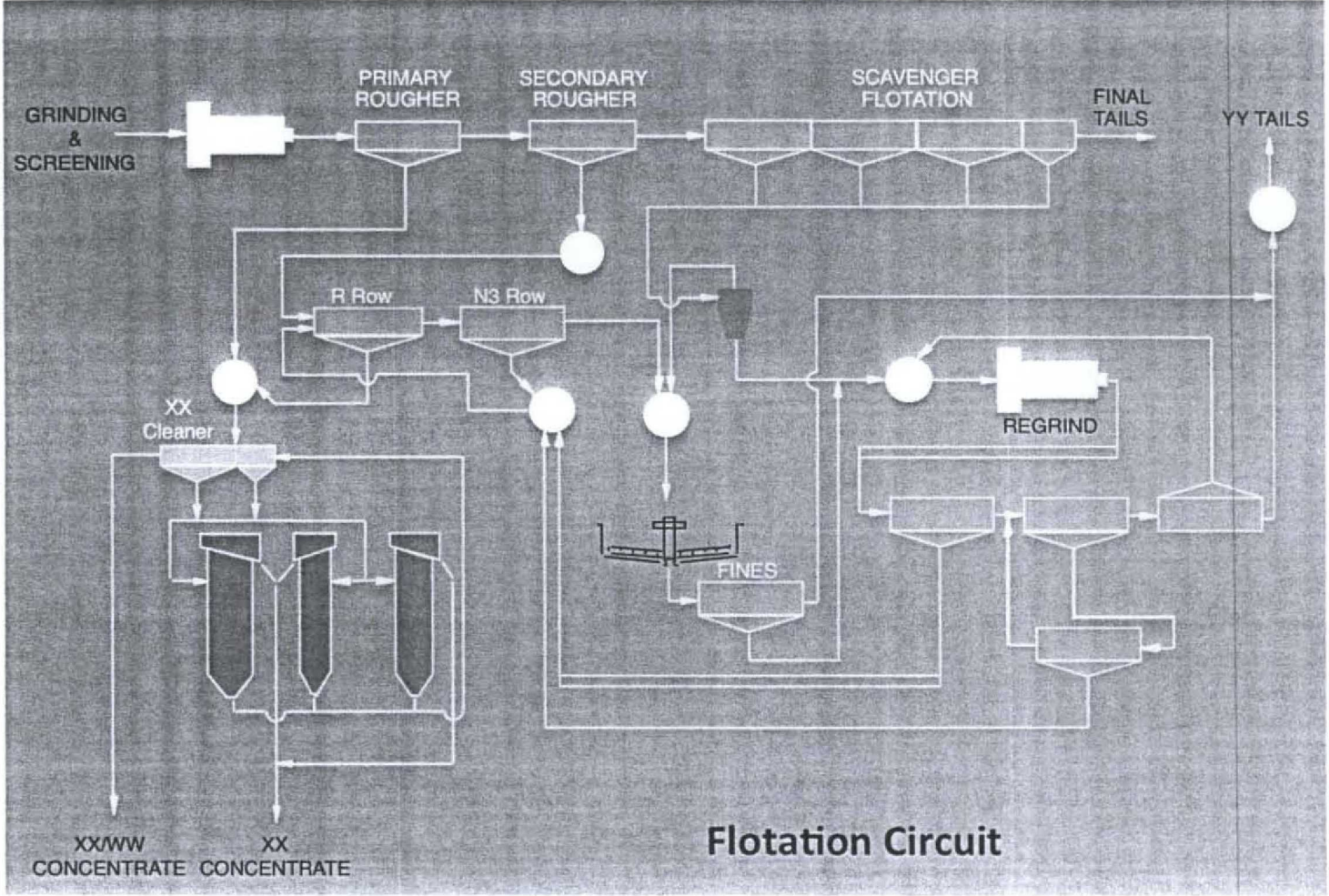

Flotation Circuit



Jar of NU-LHT

Segregation in simulant due to handling. Note the complex layering which indicates multiple episodes of sorting and probably multiple controlling factors.

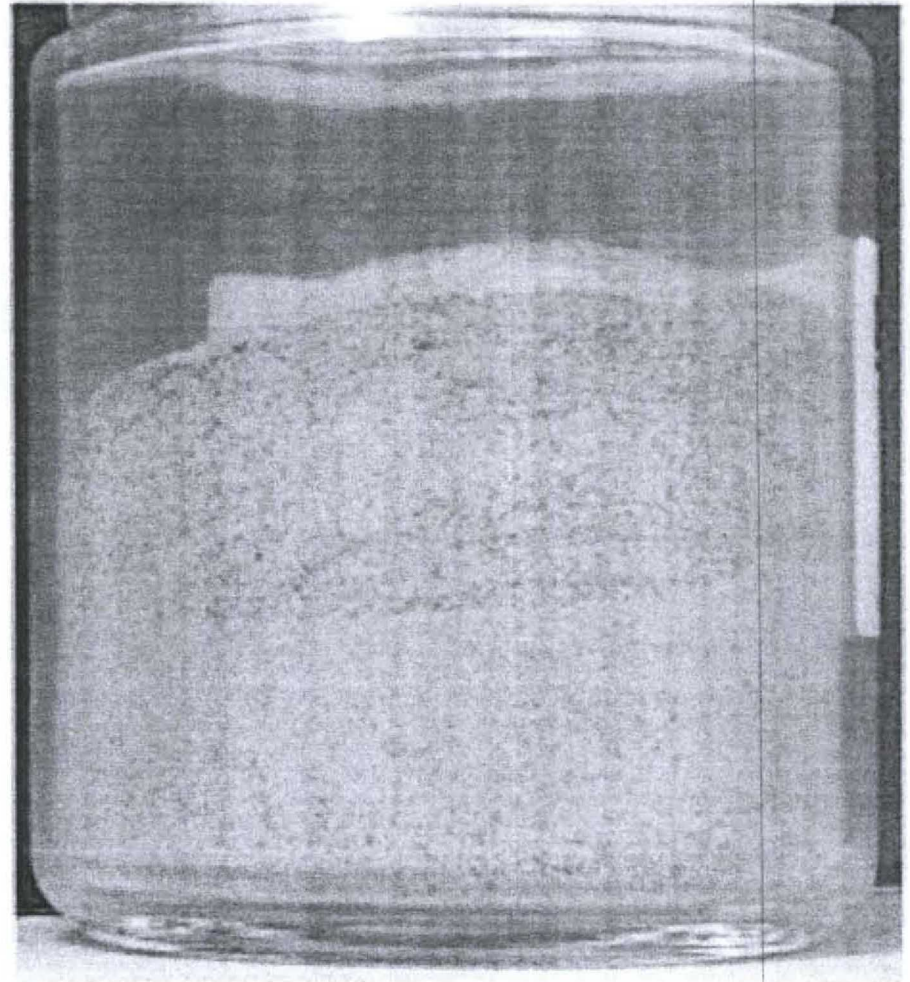

Photo from report by Intellection



Simple Cost Example, part 1

The requirement is to make a test area 100' x 100' filled 3 feet deep using whatever is locally used as road fill.

Conversion factors and handy approximations

$$1 \text{ ft}^3 = 0.0283\text{m}^3 = 28,300\text{cm}^3$$

$$1 \text{ lb} = 0.45 \text{ kg}$$

The regolith weighs approximately 1.6 g/cm^3

Simulant weight/volume

$$45.3 \text{ kg/ft}^3 = 100 \text{ lb/ft}^3$$

$$1 \text{ m}^3 = 1,600 \text{ kg}$$



Simple Cost Example, part 2

Local bulk rock for road fill is ~\$10/ton (English).
Haul cost for local material is ~ \$10/ton (English)

| | |
|-------------------|---------------------------|
| Volume | - 30,000 ft ³ |
| Weight per volume | - 100 lb/ ft ³ |
| Unit conversion | - 2000 lb/ton |
| Cost per ton | - \$20/ton |
| Total weight | - 1,500 tons |
| Final cost | - \$30,000 |

Notes:

Road fill is not sized and is very coarse.

The cost of distributing the rock once it is dumped is not included.



Elements of Regolith Simulant's Cost Structure

Introduction

The cost of lunar regolith simulants is much higher than many users anticipate. After all, it is nothing more than broken rock. This class will discuss the elements which make up the cost structure for simulants. It will also consider which elements can be avoided under certain circumstances and which elements might be altered by the application of additional research and development.

Complex Costs, including development

First, there are some cost elements that are normally built into a purchase price that may or may not be fully present in the cost structure of a given simulant. For simulants some of these costs are fairly difficult to categorize or measure for various reasons. We will consider here development, advertising and overheads.

Probably the largest single example of this is the cost of development. NASA has clearly invested many hundreds of thousands of dollars over decades developing simulants. Repeatedly. Commercial and other simulant suppliers have also spent very large sums in development. How each accounts for and attempts recovery of those costs is specific to each and is frequently either proprietary or never actually accounted for discretely.

A further problem related to development costs is that details of the processes and procedures used to make a given simulant are either proprietary or are never documented in sufficient detail for another party to reproduce the work. One result is of course the recurrence of costs associated with repeatedly, redeveloping "wheels." It is in explicit recognition of this cost element that the MSFC team has stated from the beginning that all development work that it funds will be documented in detail. This will not lessen the original cost of development, in fact it increases it, but it will at least lessen some of the future costs.

Another cost usually built into a product's price is advertising. Generally, this is minimal for simulant, but it does exist. In many cases this is the proper accounting code for attendance at workshops, meetings, and conferences. Though, on the overall scale of costs this is actually a pretty small item.

Overheads are especially problematic for simulants. Consider some examples of what may go into overhead: equipment – purchase, wear and tear, maintenance, storage of various kinds, personnel, taxes, cost of money. These are real costs, but how they are accounted for or if they exist in a specific case is highly variable. And

several of them are very sensitive to how often purchases are made and how much material is bought at any one time.

The buyer of simulants should expect to pay for these elements, one way or the other.

Scale

Anyone dealing with rock quickly learns that almost all of the costs associated with handling rock are highly scale dependent. The total cost always goes up as more material is handled, but the cost per unit weight drops. The reason for this is the vast range of different technologies that are available for the different tasks. Mining and related industries are easily some of the largest commercial operations in the world and the resources being handled are extremely complex and variable. Therefore a lot of technology has been developed for handling rock. Simulant manufacture takes advantage of this technological base.

The specific equipment used for almost every processes is tuned to a given rate of production, as well as for other variables. For example one can buy a jaw crusher which can handle feed of a few centimeters or feed up to a couple of meters or feed somewhere in between. The small units you feed by hand and they can crush at most a couple of hundred kilograms in a long, hard day. The large units handle tens of thousands of tons a day.

The result is that any producer of simulants will always be interested in both the total amount of material, the tonnage, and the rate of procurement. The latter includes both a frequency of purchase and how much lead time the purchase will have. These questions permit him to determine what equipment will be needed, which of course drives costs. It is a fallacy to think that the choice of equipment is fixed by selection of the simulant manufacturer. Many of the crushing and grinding operations needed are actually subcontracted to custom mills. So again, how much tonnage and how fast are major cost elements for simulant production. And buyers need to be aware that their cost is extremely scale dependent.

Related to scale is weight. The simulant is heavy on a per volume basis. Small volumes are easily moved by an individual. But even a 5 gallon bucket of the material needs to be handled with care. This has implications for cost through out the simulant manufacturing process. If the weight at any one step becomes greater than can be practically handled by an individual equipment has to be employed. Equipment has obvious additional costs associated.

Elements Generally Present

Now let us consider a suite of cost elements which, to a first approximation are going to be present in almost any simulant. Noting the caveat of scale dependance, the following discussion will presume that approximately a ton, 2000 kg, of simulant will be made.

Acquisition of feedstock(s)

Assuming one knows where to get the appropriate feedstock(s), one still has to get it(them). What this means depends on many variables, such as the use of the simulant, the technology being used for processing, and the geology of the resource. This may mean simply writing a purchase order to a quarry or it may mean sending very high skilled experts to pick up each single piece of rock by hand. It can also mean calling a standard scientific supply house or a specialist company and ordering specific minerals. It can also mean buying materials, such as commercially manufactured beta tri-calcium phosphate.

On the extremely low end of possible costs, ordering bulk rock from a commercial quarry, expect to pay at least \$10/ton. If you buy enough tons. How much is enough tons? It will depend on the quarry operator. It may be 10 – 50 tons. It could be many thousands of tons. It depends on his market and his desire to work with an unusual customer trying to make something for NASA.

On the high end of costs on a per kilogram basis are the purchases of specific minerals. These can range from \$100 to \$1000 or more per kilogram very easily. It depends largely on what the usual commercial market is for the material and the geologic abundance of the mineral. Some of the minerals of interest, for example apatite and the spinels, are gemstones. We buy the low end material.

At an intermediate price per kilogram is the material which is picked up by hand by experts. Currently, the development led by MSFC makes a lot of use of this technique. At Stillwater, as is the case for most geologic resources, the rock is not uniform. It varies substantially at all spatial scales. Much of that variance includes the relative abundance of minerals that would be detrimental to the simulant. Hand picking substantially reduces amount of the objectionable components. The cost of this can be crudely estimated to be on the order of \$1000/ton for lots of 10 tons.

Shipping

Shipping is always a big cost item when one deals with many tons of material. When doing a cost element analysis for shipping there are normally two dominant variables, weight and distance. For simulant work there are shipping costs at several stages. The raw feedstocks have to be shipped from their quarry or mine source. Intermediate products may have to be shipped one of more times, such as to and from milling operations or to and from a glass making operation. Finally, there is of course the shipping of the final, packaged product. As a rough guide, it is reasonable to expect to pay approximately \$1000 to move a ton of rock from Stillwater, Montana to Denver, Colorado.

Storage

Storage can become a significant cost element at multiple stages in the creation of a simulant. Very often the producer will not want to store bulk feedstocks outside

for various reasons. For example wet, frozen rock requires heavy equipment to even move. Material stored outside will quickly develop "biological activity" and can also pick up dust and other contamination from the atmosphere. The moisture content of the feedstock also can affect the behavior in milling or other processes. If a component or product has to be protected from the Earth's atmosphere, and there are various reasons this can be necessary, there is an obvious impact on cost.

As with shipping, storage costs can accrue at several stages of processing. Think of how you would store 10 tons of rock. A lot of facilities don't want anything like that in their warehouses because their forklifts aren't rated to move such weight and the containers would have to be stored on the floor, which gets in the way of other activities.

Processing

Conversion of the feedstocks into the final simulant has many steps. The individual processes may be done in serial, iterative or recursive manner. Rarely are they done in parallel at the scales of production relevant to simulant production. The complexity of the processing is driven by details such as the complexity of the starting materials, the products and the fidelity to specified criteria. The point is emphasized because with complexity comes cost.

To illustrate the complexity Figures 1 – 3 are provided. The first illustrates the complexity involved in the single step of separating plagioclase from pyroxenes in what the USGS and MSFC team refers to as "road norite", one of the rocks of interest at the Stillwater Mine. This is a circuit that would be reasonable for production at scales up to 1 ton of concentrate. The other two are circuits for portions of commercial mills processing a metal bearing ore.

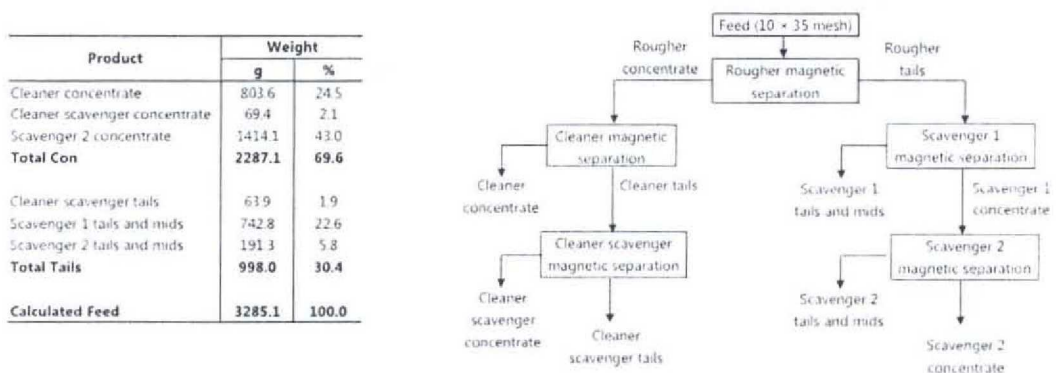

Figure 1 Magnetic separation flowchart for a "road norite" in a single size range. Reproduced from a report by Hazen Research, Inc. to the USGS.

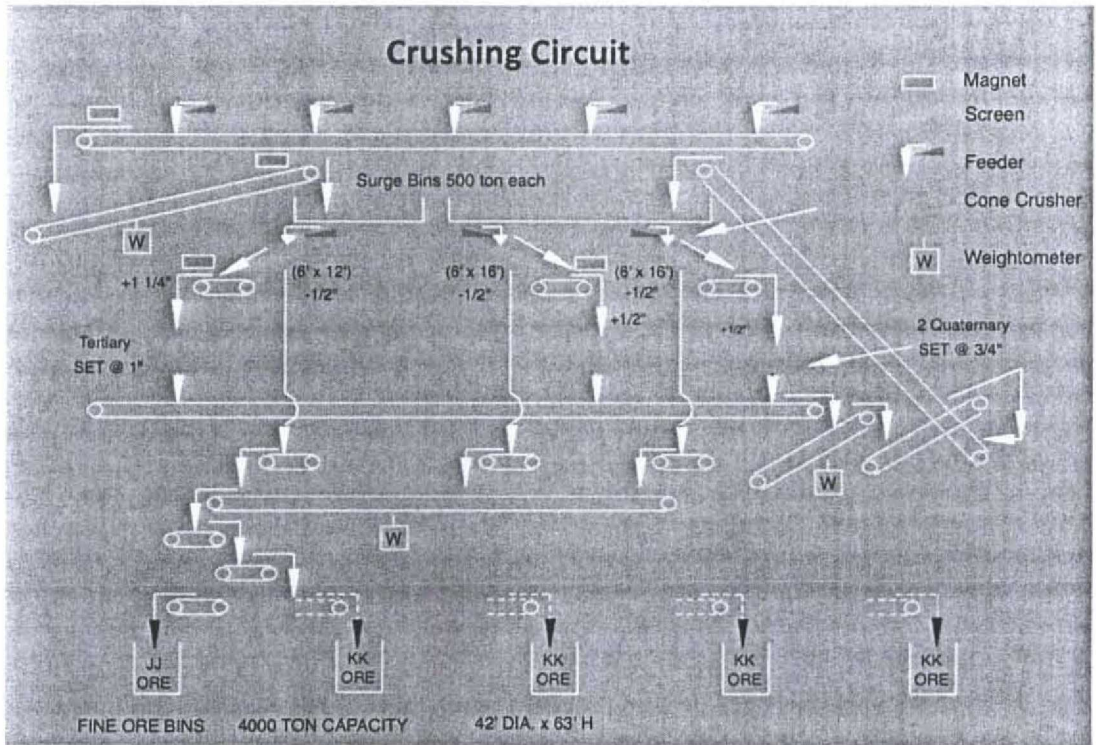

Figure 2 Second stage crushing at a 5000 ton/day mill

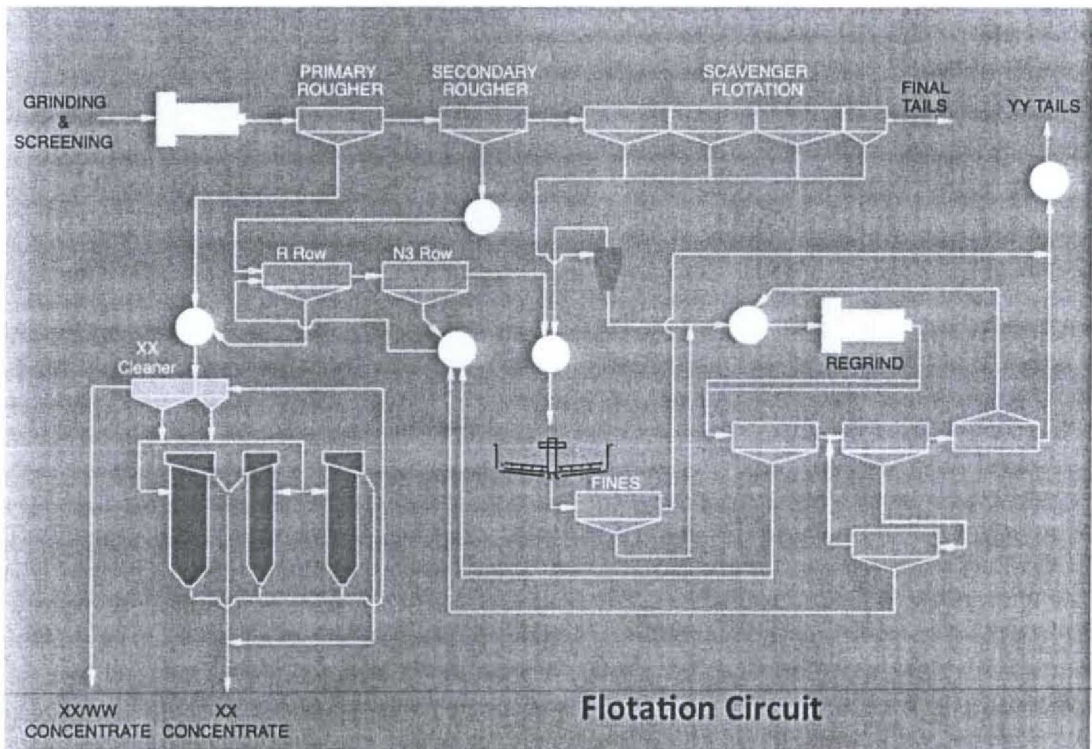

Figure 3 Flotation circuit for a mill producing 2 concentrates and 2 tails

The details of the illustrations are not important for this discussion. What is important is the illustrations are complex. The processes involved in making simulants are often subtly complex and require considerable technical expertise. Of course this affects cost; purchasers pay for expertise.

Processing for the NU-LHT series materials begins with various hand operations. These can include washing, hand sizing and breaking larger rocks with a sledge hammer. Washing is done because ordinary soil would be a contaminant in the simulant. Hand sizing and sledge hammer work The first stage of mechanical comminution can only take rocks smaller than a few inches, but it is more efficient to pick up much larger rocks at the outcrop, so it is necessary to make small ones out of big ones. In all of these hand processes the individual doing them has to be watchful for inappropriate rock that has passed previous steps unnoticed. In terms of cost it is easy to say that these hand steps are relatively low skill and therefore should not be very expensive. The problem arises for the producer that he does not have an infinitely variable labor pool. Therefore, he will almost certainly have to use a much higher skilled (expensive) person for these simple jobs than would otherwise be expected.

Again, scale becomes important. If there is enough of the material to process it becomes effective to take the rock to a crushing mill. There it will be mechanically washed and equipment of several scales will be available which can take the larger rocks and reduce them to a size needed for the next steps. This is practical at scales of roughly 10 – 100 tons. At even larger scales, 1000 – 100,000 tons it is practical to move the equipment to the feedstock. It is much easier to move small rocks than to move large rocks. But again, this is only cost effective if enough material has to be handled.

Finally consider waste. At each processing step some fraction of the input material reports to the input for the next step. The difference from unity is generically termed wastage. Wastage occurs for many reasons and is functionally unavoidable. For example the material picked up at the mine will have some pieces that should not have been picked up. Commercial crushing or grinding mills process a wide range of materials. Many of which are serious contaminants for other materials they also process. A standard way to clean between different types of input is to run a short batch of the second material and throw it away, as it will be contaminated with the first material. Simple. Easy. Cheap. Effective. And it wastes material. The wastage has to be accounted for in the cost modeling.

Milling

Crushing and grinding reduce the rock to the desired final sizes. Factors that drive costs in these stages include capital costs, media use, maintenance costs and energy consumption. Breaking rock uses an enormous amount of energy. Maintenance is a major task. Most crushing and grinding techniques consume a media, for example steel balls. The equipment is extremely expensive. The purchaser of simulants will have to pay for all of these. And this is where scale

dependence becomes preeminent. As noted before jaw crushers range from machines able to accept gravel to machines able to accept man-sized boulders. Grinding containers can be small enough to carry easily in one hand. Or they can be 10 meters in diameter.

Milling also includes mixing. Anyone familiar with the handling of particulates knows that collections of particles can be automatically separated based solely on the properties of size, shape, or density. Indeed, in many cases it is very hard to prevent the separation, see Figure 3. Current simulant processing techniques require the combination of multiple feedstocks. Therefore, mixing is a major concern in simulant production. There are many ways to do this. The choice of

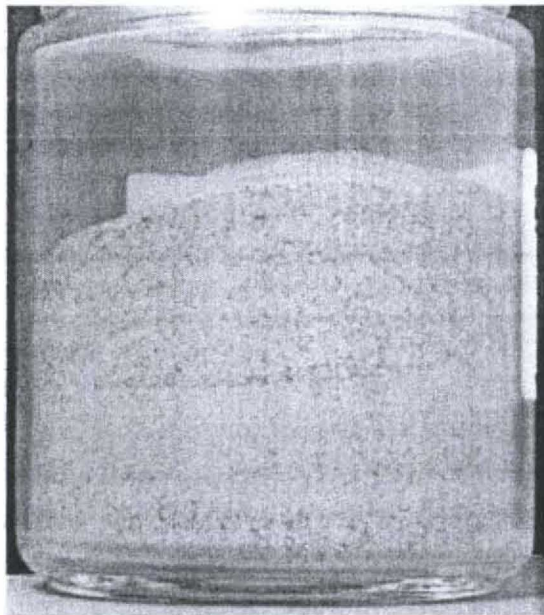

technique will depend very much on how perfect a mixture is required and scale.

Figure 4 NU-LHT simulant showing segregation due to handling. Photo from Intellection report on simulants

Packaging is the final step in milling. What is simplest (cheapest) for the manufacturer will depend on his physical plant. A major concern for the manufacturer in this choice is not just getting the simulant packaged but how does he move the package once loaded? $\frac{1}{4}$ kg glass jars are easy to move but there sure are a lot of them required for 1 ton of simulant. A 1 ton bag is simple but requires a pallet and forklift to move, with the required room to maneuver.

Measurement

Measurements of the material have to be made at multiple steps in the processing as well as on the final product. Size distributions and chemistry can be checked several times during processing. Individually, these costs are not great but they are real. Post-processing measurements are more extensive. The parameters of the FoM have to be quantified, which goes far beyond size and chemistry. These tests are largely independent of the tonnage produced. More accurately they are functions of how the production, especially the final mixing, is done.

Synthesis

Several of the components in lunar regolith either do not naturally occur on Earth or are extremely rare. The obvious example for most people is the agglutinate particles. But the list also includes the minerals troilite and whitlockite and terrestrial obsidian (natural glass) is the wrong composition. These are important in the simulants for various reasons, including both mechanical and chemical properties. The only practical solution to obtain these is to synthesize them. In at least one case, whitlockite, the material is commercially available. It is known as beta tri-calcium phosphate. It is used for such things as toothpaste abrasive. The required glasses and agglutinates do not have commercial markets, so these must be made by the simulant manufacturer. Synthetic glass with appropriate composition will cost on the rough order of \$10,000-\$15,000/ton of glass for quantities in the 1 – 5 ton range. Again, scale is important in cost.

Agglutinates are a special problem for lunar regolith simulant. Many people have attempted their synthesis but only one organization, Orbitec¹, has achieved something that appears to be really close to the lunar prototype. And their current process is scaled at kilograms, not tons. Others have had varying levels of success reproducing various properties. For example the USGS with Zybek has been able to make a pseudo-agglutinate, which lacks nano-phase iron, in the 100 kg range. The user has to be very careful about what properties are really needed. Small changes in requirements can have drastic price impact.

Profit, Risk and Time

The final cost elements to consider are profit, risk and time. These apply to any element in the model that is open market. Risk is especially difficult to quantify but is a dominant consideration for developers, manufacturers and vendors. If they invest \$250K of their own money in development of a simulant what is the risk it will not be sold? In economic theory it is a classic statement that decreasing risk decreases cost. Time is also classically associated with cost. Again assume the

¹ Commercial names are used for clarity and completeness. This does not imply endorsement by the NASA or the Federal government.

vendor has put out \$250K. How soon will he get the material sold? The longer it takes the higher the cost to the ultimate buyer.

A simple cost example

Now consider a set of costs for a relatively simple problem: making a test bed large enough to drive large equipment on. The requirement is to make a test area that is 100 ft x 100 ft filled 3 feet deep using whatever is locally used as road fill. Note, road fill can be almost any rock. Its major requirement is cheapness.

Begin by tabulating some basic characteristics.

The regolith weighs approximately 1.6 g/cm^3

Conversion factors - $1 \text{ ft}^3 = 0.0283 \text{ m}^3 = 28,300 \text{ cm}^3$; $1 \text{ lb} = 0.45 \text{ kg}$

Simulant weight per volume - $45.3 \text{ kg/ft}^3 = 100 \text{ lb/ft}^3$; $1 \text{ m}^3 = 1,600 \text{ kg}$

Local bulk rock for road fill is $\sim \$10/\text{ton}$ (English).

Haul cost for local material is $\sim \$10/\text{ton}$ (English) This assumes a dump truck able to make several trips from the quarry to construction site each day.

| | |
|-------------------|---------------------------|
| Volume | - 30,000 ft ³ |
| Weight per volume | - 100 lb/ ft ³ |
| Unit conversion | - 2000 lb/ton |
| Cost per ton | - \$20/ton |
| Total weight | - 1,500 tons |
| Final cost | - \$30,000 |

This cost does not include the labor or equipment costs involved in distributing the fill around the test area. Remember, you are trying to move over a thousand tons of rock. That's when it is dry. Its weight will go up a lot when it gets rained on.

The material specified above, rock for road fill, will be much too coarse to simulate lunar regolith, so additional crushing will be necessary. Depending on the exact specifications for this, such as the size distribution required, this will add an additional \$100/ton to \$5,000/ton or more to the cost.

For tests where the composition of the particles matter, such as abrasion or energy expenditure, then very few areas in the United States have the correct rock to make reasonable simulants. For such applications material will have to be brought from a distant source. We are currently using a mine near Columbus, Montana. Shipping costs from there to anywhere in the United States, for large enough quantities, can be arranged for roughly \$50/ton. "Large enough quantity" in this case is a railroad car. Smaller quantities shipped by truck will cost more.

Glass is not a common constituent of road fill aggregates. If having glass in the test material is important then the source rock will have to contain significant glass or it will have to be added from either natural or synthetic sources. Glass can be obtained several different ways. It is a constituent of rocks like basalt. The slag from smelters is a glass. These can be used if composition is not too big a concern. Synthetic glass with appropriate composition can also be purchased.

If having agglutinate like material in the simulant is important, it will substantially add to the cost. As there is no standard commercial analog that can be substituted, it must be made just for this use and is an adaptation of the process used to make the synthetic glass.

Conclusion

Studying the elements in a cost model for simulants reveals considerable complexity. The process feeds are multiple, internally complex and variable. The technologies used are very scale dependent, ranging over many orders of magnitude. Many of the constituents for acceptable grades of simulant have to be synthesized. Risk and time are major considerations for manufacturers. Weights of the feedstocks, intermediate products and the final simulant are high.

A final point about costs, the numbers given above are for illustration only. They are reasonable within their context. In addition to quantity they are also very sensitive to the exact processes used, the experience level of the producer, how much development is required and how reproducible samples of the simulant must be. It is completely reasonable to expect that different simulants could range in price per ton by more than a factor of 100 or even more.