

T/R Multi-Chip MMIC Modules for 150 GHz

A transmitting gain of 14 dB at 150 GHz has been demonstrated.

NASA's Jet Propulsion Laboratory, Pasadena, California

Modules containing multiple monolithic microwave integrated-circuit (MMIC) chips have been built as prototypes of transmitting/receiving (T/R) modules for millimeter-wavelength radar systems, including phased-array radar systems to be used for diverse purposes that could include guidance and avoidance of hazards for landing spacecraft, imaging systems for detecting hidden weapons, and hazard-avoidance systems for automobiles. Whereas prior landing radar systems have operated at frequencies around 35 GHz, the integrated circuits in this module operate in a frequency band centered at about 150 GHz. The higher frequency (and, hence, shorter wavelength), is expected to make it possible to obtain finer spatial resolution while also using smaller antennas and thereby reducing the sizes and masses of the affected systems.

The integrated circuits contained in the present T/R modules include low-noise amplifiers and power amplifiers previously reported in *NASA Tech Briefs*, variously, as separate chips or modules in "MMIC HEMT Power Amplifier for 140 to 170 GHz" (NPO-30127), Vol. 27, No. 11 (November 2003), page 49; and "Power-Amplifier Module for 145 to 165 GHz" (NPO-40260), Vol. 31, No. 2 (February 2007), page 38. The module housings (see figure) were made from gold-plated brass and include flanges for input and output WR-5 waveguides. [A WR-5 waveguide, nominally designed for operation in the G Band (140 to 220 GHz), has an internal cross section of 0.0510 by 0.0255 in. (about 1.30 by 0.65 mm).]

Each module contains two branches: one for transmitting and one for receiving. Two modules — one containing only the transmitting circuitry, the other containing only the receiving circuitry — were fabricated for initial experiments in which they were tested separately. The transmitting-only module contained two MMIC power-amplifier chips that were fabricated at HRL Laboratories, LLC. The chips were separated by microstrip transmission lines made partly of alumina, and a WR-5

electric-field-plane probe was used to make the transition from the microstrip mode to the waveguide mode. Wire bonds were used to connect the transmission lines to the chips. DC connections were made by means of feedthroughs mounted through the module and connected to bias circuit boards with external multi-pin connectors. At the time of reporting the infor-

mation for this article, the transmitting-only module had been tested and found to afford about 14 dB of gain over the frequency range from 148 to 150 GHz.

This work was done by Lorene A. Samoska, David M. Pukala, Mary M. Soria, and Gregory A. Sadowy of Caltech for NASA's Jet Propulsion Laboratory. Further information is contained in a TSP (see page 1). NPO-46074

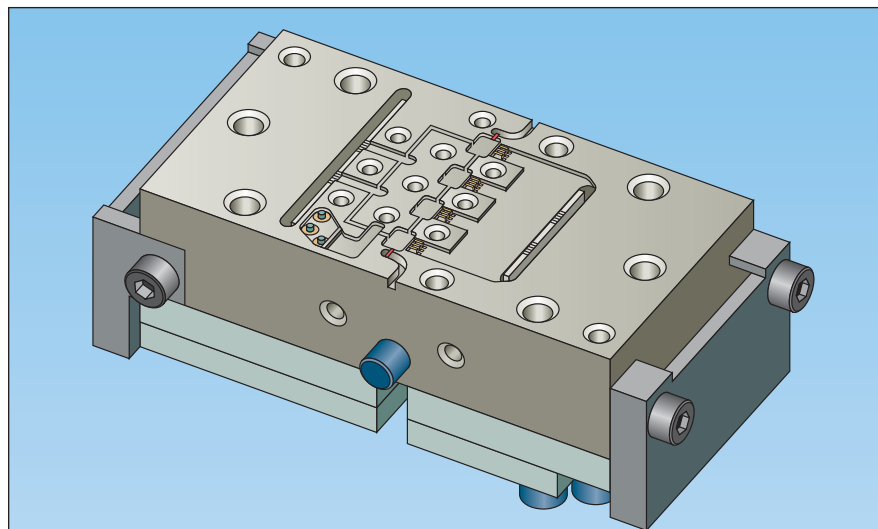

Sketch of Module Housing With Lid Open

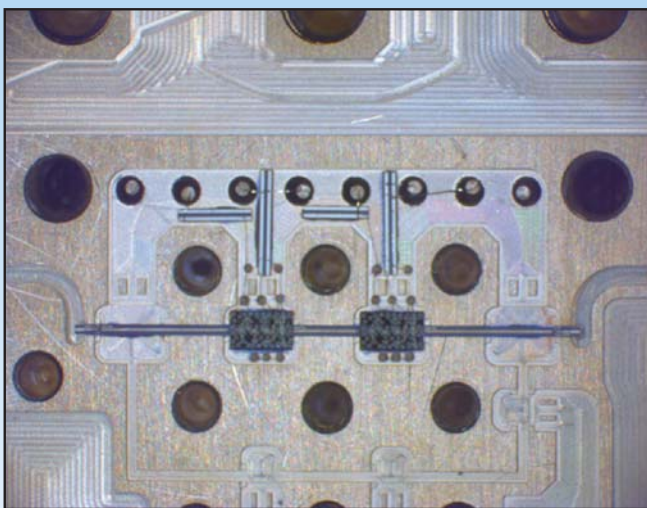

Photograph Showing Input and Output Waveguides, Electric-Field-Plane Transition, Microstrip Lines, and Power-Amplifier MMICs in Transmitting-Only Module

The Module Housing Contains Cavities wherein MMIC chips are placed.